

P268666 (01)

25

Copies Received 75

Date 17-6-86

AGARD-R-728

AGARD-R-728

AGARD

ADVISORY GROUP FOR AEROSPACE RESEARCH & DEVELOPMENT

7 RUE ANCELLE 92200 NEUILLY SUR SEINE FRANCE

AGARD REPORT No.728

Gust Load Prediction and Alleviation on a Fighter Aircraft

NORTH ATLANTIC TREATY ORGANIZATION



DISTRIBUTION AND AVAILABILITY
ON BACK COVER

NORTH ATLANTIC TREATY ORGANIZATION
ADVISORY GROUP FOR AEROSPACE RESEARCH AND DEVELOPMENT
(ORGANISATION DU TRAITE DE L'ATLANTIQUE NORD)

AGARD Report No.728
GUST LOAD PREDICTION AND ALLEVIATION
ON A FIGHTER AIRCRAFT

by
J.Becker

THE MISSION OF AGARD

The mission of AGARD is to bring together the leading personalities of the NATO nations in the fields of science and technology relating to aerospace for the following purposes:

- Exchanging of scientific and technical information;
- Continuously stimulating advances in the aerospace sciences relevant to strengthening the common defence posture;
- Improving the co-operation among member nations in aerospace research and development;
- Providing scientific and technical advice and assistance to the Military Committee in the field of aerospace research and development (with particular regard to its military application);
- Rendering scientific and technical assistance, as requested, to other NATO bodies and to member nations in connection with research and development problems in the aerospace field;
- Providing assistance to member nations for the purpose of increasing their scientific and technical potential;
- Recommending effective ways for the member nations to use their research and development capabilities for the common benefit of the NATO community.

The highest authority within AGARD is the National Delegates Board consisting of officially appointed senior representatives from each member nation. The mission of AGARD is carried out through the Panels which are composed of experts appointed by the National Delegates, the Consultant and Exchange Programme and the Aerospace Applications Studies Programme. The results of AGARD work are reported to the member nations and the NATO Authorities through the AGARD series of publications of which this is one.

Participation in AGARD activities is by invitation only and is normally limited to citizens of the NATO nations.

The content of this publication has been reproduced directly from material supplied by AGARD or the author.

Published June 1986

Copyright © AGARD 1986

All Rights Reserved

ISBN 92-835-1532-3



Printed by Specialised Printing Services Limited
40 Chigwell Lane, Loughton, Essex IG10 3TZ

CONTENTS

	Page
INTRODUCTION	1
CONSISTENCY WITH MILITARY REQUIREMENTS	1
METHODS FOR CALCULATING THE DYNAMIC RESPONSE OF FLEXIBLE AIRCRAFT IN TURBULENCE	1
EXAMPLES OF FLEXIBLE AIRCRAFT TURBULENCE RESPONSE PREDICTIONS	6
RIDE COMFORT EVALUATION	10
STRUCTURAL COUPLING PROBLEMS	12
ACTIVE GUST CONTROL ON FLEXIBLE AIRCRAFT	12
CONCLUSIONS	16
REFERENCES	16

GUST LOAD PREDICTION AND ALLEVIATION ON A FIGHTER AIRCRAFT

by

J. Becker

MESSERSCHMITT-BÖLKOW-BLOHM GmbH.
Airplane and Helicopter Division
P.O. Box 801160, 8 Munich 80
W.-Germany

Contribution to the AGARD-Activity
"Flight of Flexible Aircraft in Turbulence"

INTRODUCTION

Turbulence induced dynamic loads and vibrations on a fighter aircraft may play a considerable role for certain configurations with respect to the design of the structure and the performance of special missions or they may cause on the other hand limitations of the flight envelope.

As far as aircombat aircraft are concerned typical restrictions may be found for instance with respect to design gust loads if wing tip mounted store configurations are investigated or with respect to ride comfort if low level high speed missions are evaluated. Here both aspects namely design gust critical cases and ride comfort are therefore reported in more detail in order to demonstrate the problem areas. In this context also some difficulties of turbulence response prediction methods will be described, especially with respect to the dynamics of the aircraft with FCS and the interaction of flight and structural dynamics, though these methods are well established. In addition problem areas of the aircraft with FCS and gust alleviation system are mentioned for the case of ride improvement. The design of such systems would strongly necessitate the full dynamic description of the flexible fighter aircraft in order to evaluate maximum loads, fatigue loads and structural coupling problems with the control system.

CONSISTENCY WITH MILITARY REQUIREMENTS

The following problem areas may be of importance for the aircraft with FCS and for dynamic load alleviation and ride improvement systems. During the development of a system for the proper achievement of ride smoothing, as for instance based on the requirements as specified in MIL-F-9490 D (USAF) chapter 3.1.2.12, or for the purpose of gust load alleviation (MIL-A-8861 requirements) of course the controlled aircraft must be investigated with respect to

- degradation of flying qualities and handling
- adverse effects on airplane strength and rigidity:
flight loads, fatigue loads, vibration, flutter and aeroservoelastic stability, because conflicts could exist between the different specifications. In detail the below mentioned aspects should be considered.
- stability
destabilisation of aircraft modes or structural modes. Structural coupling problems in flight followed by degrading effects on stiffness and on elastic mode damping or aeroservoelastic flutter.
- Static and dynamic loads:
Change of maximum design loads and fatigue loads caused by control surface activities.

In addition all effects caused by system limitations (actuator power, control surface rates and deflection) should be investigated and a system failure strategy developed.

METHODS FOR CALCULATING THE DYNAMIC RESPONSE OF FLEXIBLE AIRCRAFT IN TURBULENCE

Several methods are well established for the calculation of the flexible aircraft in turbulence. Of course these methods have their own advantages but are not necessarily in a stage for the solution of specific problems especially occurring if static unstable

aircraft configurations are considered or gust alleviation systems are investigated. Two approaches will in general be used in parallel:

- a) The solution of the nonlinear flight dynamic equations of motion of the aircraft with flight control system dynamic equations together with structural dynamic equations in time domain.
- b) The solution of linearised flight dynamic equations of motion of the aircraft with coupled structural dynamic equations in frequency and in time domain.

The calculation of the dynamic response in time domain using a) includes the simulation of nonlinear effects at severe disturbance conditions, as for example aerodynamic nonlinearities (which are included in the static aerodynamic data set), rate and deflection limitations of the control surfaces due to marginal actuator power and inertia coupling at high rates.

Several disadvantages may arise in this approach if effects of the flexible aircraft on the total aircraft response are only treated in a pure quasisteady approach as normally used in flight dynamic simulation by the introduction of a flexibilised steady aerodynamic data set.

Consequently this approach could lead to a wrong prediction of local dynamic response and maximum dynamic loads.

In addition this quasisteady approach will not account for time correlated structural dynamic and flight dynamic responses since no aerodynamic coupling exists between structural dynamic and flight dynamic equations. A superposition of rigid and elastic aircraft vibrations in the right phase will not be possible. The disadvantages therefore could be found in not accurate predictions of maximum or stochastic vibrations and of dynamic loads. The analytical investigation of structural coupling effects, which are of interest especially for static unstable aircraft cannot be performed adequately by this approach.

The dynamic response approach using linearized equations of motion of the aircraft around trimmed condition coupled with structural dynamic equations and flight control equations will give the possibility to introduce the unsteady and coupling effects in a proper sense. Therefore flight dynamic and structural dynamic responses are described in the right phase and the superposition of vibration and dynamic loads from both contributions can be performed. In addition of course the stability of the total aircraft can be calculated for the flight control system closed. Open loop phase and gain margins for the total system can be investigated which would give more insight into the coupling effects of the flexible aircraft modes on the stability of the flight dynamic modes and the structural dynamic modes by evaluation of the Bode diagram in the frequency range $0 - f_{max}$. (f_{max} is the frequency of the highest flexible mode used in the analytical model). The linearised model in advance gives information about the transfer functions of all state variables, of local accelerations and of dynamic loads due to a gust input. These evaluations are also of interest especially if gust alleviation systems are studied. Besides the calculation of power spectral densities of the above mentioned variables also the incremental responses at trimmed condition can be calculated with the linearised model in time domain and nonlinear effects like rate and deflection limitations can be evaluated as well in a first step. Disadvantages can arise through the derivation of unsteady airloads at transsonic speeds or at higher incidences where some limitations of the theoretical procedures could be existent. Correction methods using experimental static or dynamic experimental results should be applied.

APPROACH 1:

Nonlinear flight dynamic equations in body fixed coordinates and structural dynamic equations without coupling.

Flight dynamic equations:

$$\begin{aligned} X &= m(\dot{U} - VR + WQ) \\ Y &= m(\dot{V} - WP + UR) \\ Z &= m(\dot{W} - UQ + VP) \end{aligned}$$

$$\begin{aligned} L &= I_{xx}\dot{P} - I_{xy}\dot{Q} - I_{xz}\dot{R} + Q(I_{xz}P - I_{yz}Q + I_zR) \\ &\quad - R(I_{xy}P + I_yQ - I_{yz}R) \end{aligned}$$

$$\begin{aligned} M &= I_{xy}\dot{P} + I_y\dot{Q} - I_{yz}\dot{R} + (I_xP - I_{xy}Q - I_{xz}R)R \\ &\quad - (I_{xz}P - I_{yz}Q + I_zR)P \end{aligned}$$

$$\begin{aligned} N &= -I_{xz}\dot{P} - I_{yz}\dot{Q} + I_z\dot{R} + (I_{xy}P + I_yQ - I_{yz}R)P \\ &\quad - (I_xP - I_{xy}Q - I_{xz}R)Q \end{aligned}$$

$$\begin{bmatrix} M_{RR} & 0 \\ 0 & M_{EE} \end{bmatrix} \begin{bmatrix} \ddot{X}_R \\ \ddot{X}_E \end{bmatrix} + \begin{bmatrix} 0 & 0 \\ 0 & D \end{bmatrix} \begin{bmatrix} \dot{X}_R \\ \dot{X}_E \end{bmatrix} + \begin{bmatrix} 0 & 0 \\ 0 & K_E \end{bmatrix} \begin{bmatrix} X_R \\ X_E \end{bmatrix} = \begin{bmatrix} L_{RR} & L_{RE} \\ L_{ER} & L_{EE} \end{bmatrix} \begin{bmatrix} X_R \\ X_E \end{bmatrix} + \begin{bmatrix} P_R \\ P_E \end{bmatrix}$$

FIG. 1 FLEXIBLE AIRCRAFT DYNAMICS COUPLED FLIGHT AND STRUCTURE DYNAMIC EQUATIONS

The following notation are used:

- X_R Degree of Freedom Rigid Aircraft
- X_E Degree of Freedom Flexible Aircraft
- L_{RR} Matrix of Rigid Aircraft Aerodynamic Coeff.
- L_{EE} Matrix of Generalised Aerodynamic Coeff.
- L_{RE} Coupling Terms (Lift and Moment due to Defl.)
- L_{ER} Coupling Terms of Rigid Motion to the Generalised Aerodynamics
- P_R Rigid Excitation Forces
- P_E Generalised Excitation Forces
- K_E Matrix of Generalised Stiffness

The aerodynamic terms and the degrees of freedom are complex functions in frequency consisting of real- and imaginary parts.

The rigid aircraft aerodynamic terms may be introduced using a experimental data set (rigid) or calculated derivatives L_{RR} (except the drag terms) using computer programs for the calculation of unsteady aerodynamic forces (Ref. 1, 2, 3), which can be applied also for the derivation of the L_{EE} , L_{RE} , L_{ER} , P_R and P_E matrices.

A more detailed structure of the longitudinal symmetric dynamics of the total aircraft is shown in matrix notation in Fig. 2, where the first four equations describe the flight dynamics excited by gust induced forces and moments. They include the aerodynamic coupling terms Z_j , M_j the normal forces and pitch moments due to total aircraft elastic modes and the control surface drag, normal force and pitch moment X , Z , M . The structure dynamic equations, excited by generalised gust forces $L_j \alpha_g$, contain also the aerodynamic coupling terms $L_{j\alpha}$, $L_{j\gamma}$.

$$[\bar{B} + i\omega\bar{A}]\{x\} = \{RHS\};$$

$$\{x\}^T = \{\Delta V/V, \Delta\alpha, \Delta\omega, \Delta\theta, q, \Delta\eta, \dot{q}, \Delta\eta_1\}$$

\bar{A}

$X_{\dot{V}}/V$	X_{α}					
$Z_{\dot{V}}/V$	Z_{α}			Z'_j/ω	Z''_j/ω	
	M_{α}	I_y		M'_j/ω	M''_j/ω	
			-1			
				-E		
						M_{jj}
	$-K^*V$					$-T2$

\bar{B}

X_T	X_{α}	X_{ω_y}	X_{θ}		X_{η}		
Z_T	Z_{α}	Z_{ω_y}	Z_{θ}	Z'_j	Z''_j		
	M_{α}	M_{ω_y}		M'_j	M''_j		
		1					
						E	
						1	
	$L'_{j\alpha}$			$K_{jj} + L'_{jj}$	L'_{jm}	$\frac{\gamma K_{jj} + L''_{jj}}{\omega}$	$\frac{L''_{jm}}{\omega}$
	K^*V				-1		$-T1$

$\{RHS\}$

X_{α_0}
$L'_{\alpha_0} + iL''_{\alpha_0}/\omega$
$M'_{\alpha_0} + iM''_{\alpha_0}/\omega$
$L'_{j\alpha_0} + iL''_{j\alpha_0}/\omega$

FIG. 2 LONGITUDINAL MOTION - FLEXIBLE AIRCRAFT DYNAMICS

The equations Fig. 1 are useful to calculate the flexibilised total aircraft derivatives for the steady case. The procedure which is recommended in case of known total aircraft normal modes is shown in Fig. 3

**MODAL APPROACH
 SOLUTION FOR STEADY CASE**

MATRIX OF ELASTIFIED AERODYNAMIC DERIVATIVES \bar{L}_{RR}

$$\bar{L}_{RR} = L_{RR} + L_{RE} (K_E + L_{EE})^{-1} L_{ER}$$

ELASTIFIED RIGHT HAND SIDE \bar{P}_R

$$\bar{P}_R = P_R + L_{RE} (K_E + L_{EE})^{-1} P_E$$

FIG. 3 DERIVATION OF FLEXIBILISED AERODYNAMIC DATA SET

As an example Fig. 4 illustrates the effects of the flexibilisation on rigid flap derivatives of a delta-canard fighter aircraft configuration.

**ELASTIFIED NORMAL FORCE AND PITCH MOMENT
 DUE TO FLAP DEFLECTION**

**MACH 0.8 at sealevel
 contribution of the different modes
 to the aeroelastic efficiency**

	$c_{z\delta_{el}}/c_{z\delta_R}$	$c_{m\delta_{el}}/c_{m\delta_R}$
MODE 1	0.85	0.92
MODE 2	0.75	0.84
MODE 3	0.69	0.80
MODE 4	0.65	0.77
MODE 5	0.62	0.74

FIG. 4 APPLICATION OF FLEXIBILISATION METHOD

EXAMPLES OF FLEXIBLE AIRCRAFT TURBULENCE RESPONSE PREDICTIONS

Some typical results of gust response calculations on a flexible aircraft are listed here in order to demonstrate the importance of arising problems.

The investigated aircraft is a delta canard configuration with wing tip mounted stores. The first example shall illustrate the prediction of vibration levels on external stores and resulting dynamic wing loads due to discrete gusts (Fig. 5).

STRUCTURAL DYNAMIC VIBRATIONS
DYNAMIC LOADS

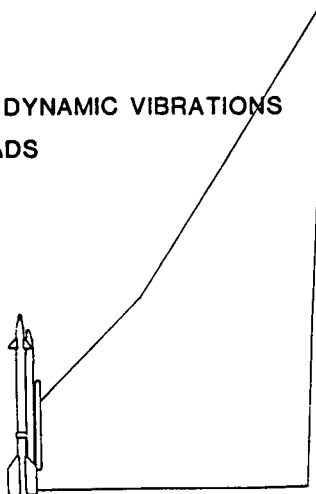

FIG. 5 WING WITH TIP MOUNTED MISSILE

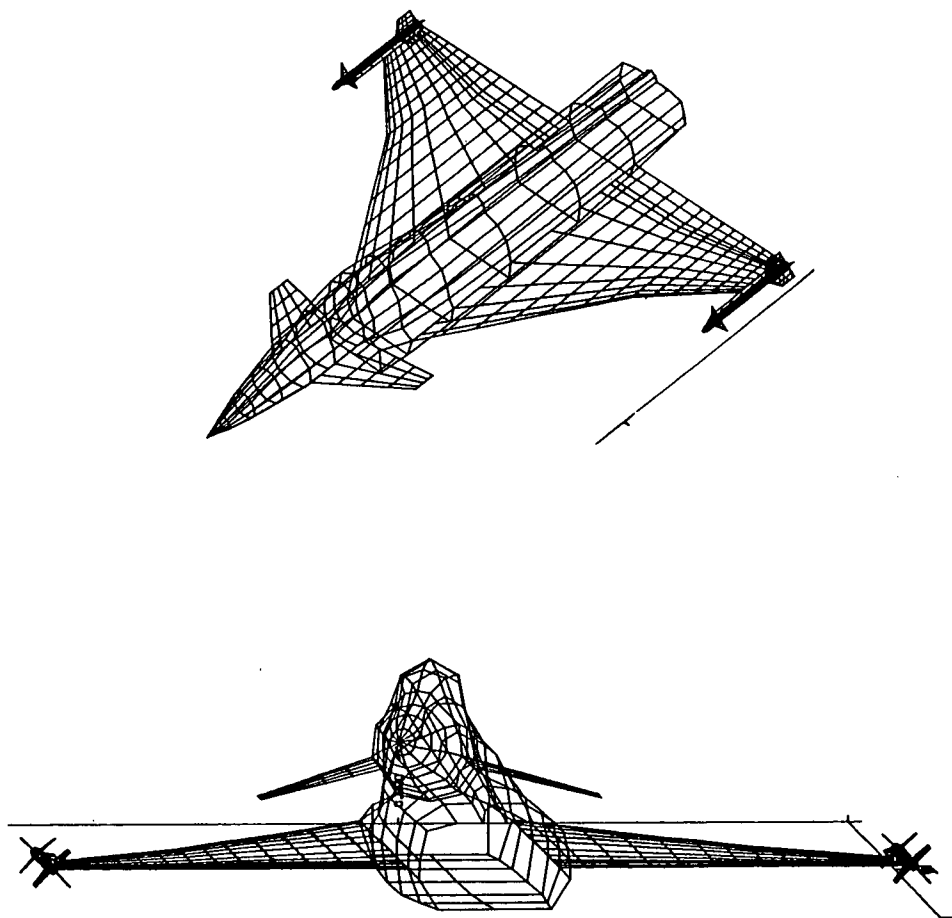

FIG. 6 AERODYNAMIC GRID

The total aircraft configuration is idealised for unsteady aerodynamic force calculation by the grid shown in Fig. 6. The unsteady aerodynamic derivatives and generalised forces together with load distributions on subcomponents are calculated with the program (Ref.3) for the degrees of freedom aircraft angle of attack, rotation around center of

gravity, canard deflection, flap deflection and wing elastic normal modes shown in Fig. 7.

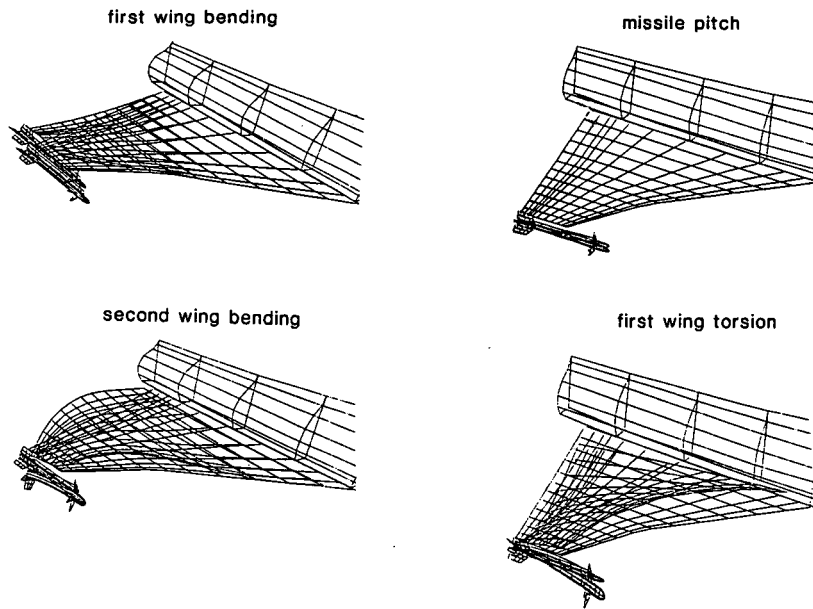

FIG. 7 VIBRATION MODES

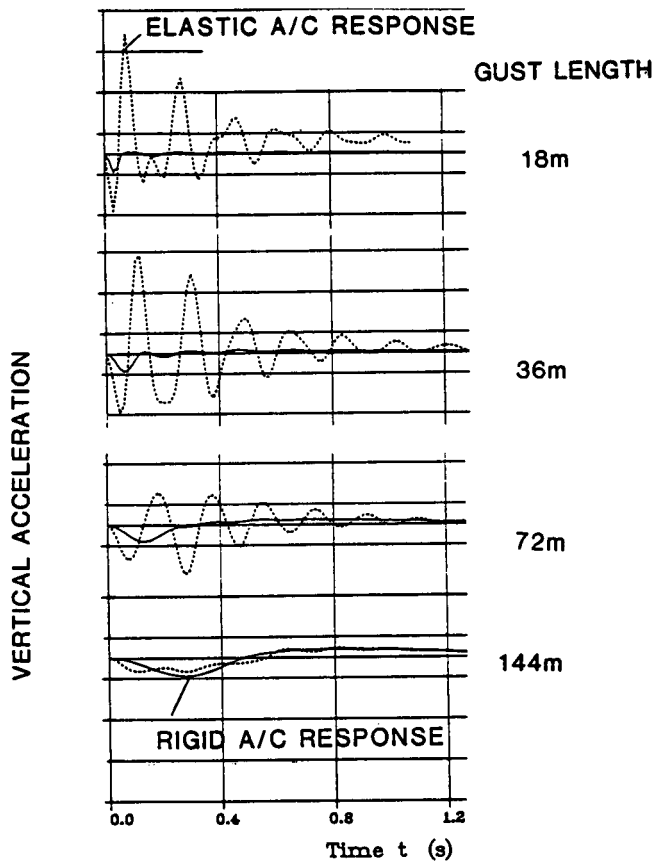

FIG. 8 DISCRETE GUST ANALYSIS: ACCELERATION AT MISSILE NOSE

Fig. 8 documents very high accelerations on the tip mounted missile due to discrete gust caused mainly at short gust length (18 m) by the second elastic mode of the wing and also shows alleviation effect of the elastic wing on the response at long gust length (144 m) compared to the rigid response (full line).

The discrete gust reponse of the flexible aircraft results in wing shear and bending distributions as depicted in Fig. 9.

Dramatic changes of wing loading are observed especially at wing outboard stations for different gust length compared to rigid response which indicate a problem area in the structural design. Gust loads may have influence on the structural design.

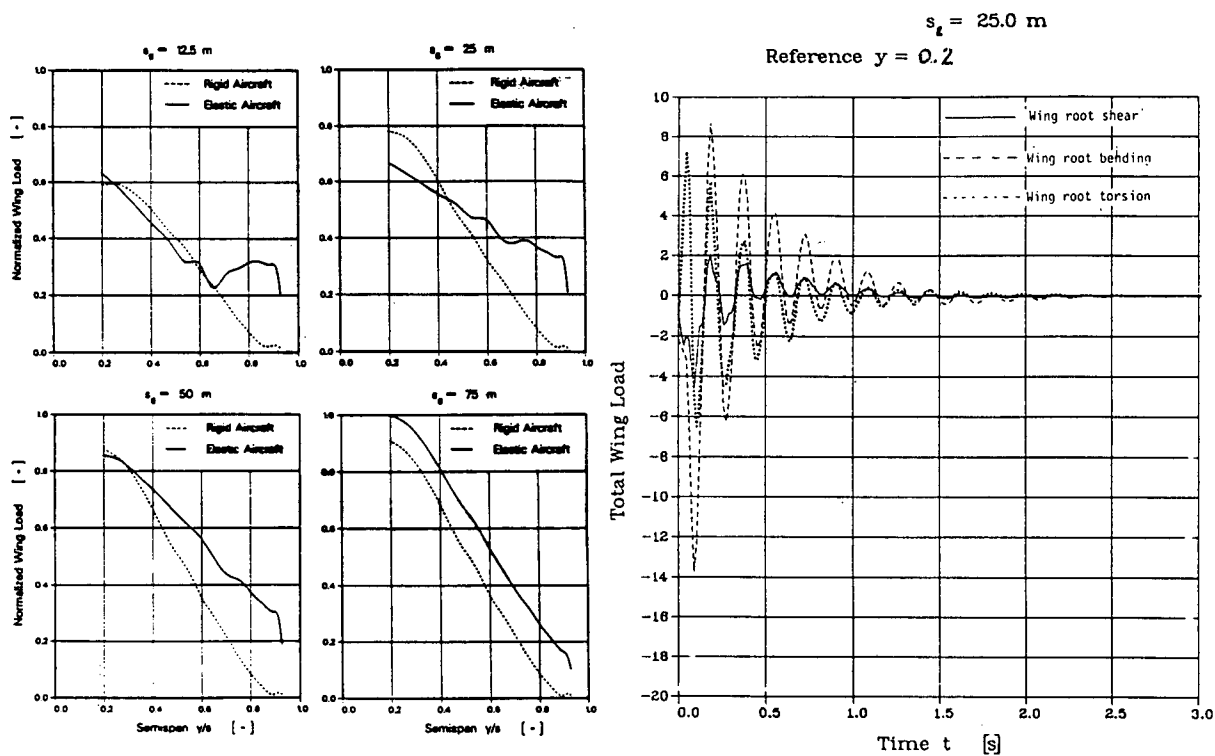

FIG. 9a DESIGN GUST CALCULATION: WING SHEAR FORCE

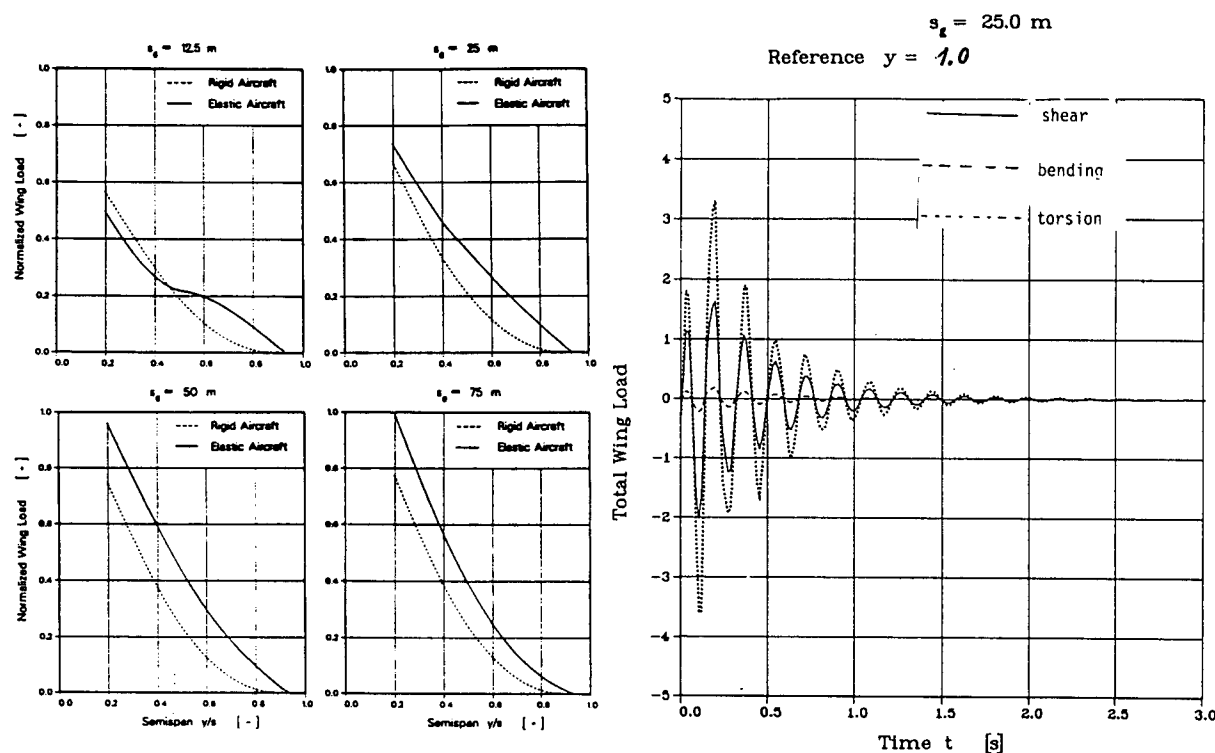

FIG. 9b DESIGN GUST CALCULATION: WING BENDING MOMENT

Summary:

Very high vibration levels and dynamic loads compared to rigid aircraft response are predicted in the tip store attachment region. Gust load alleviation can be of profit.

RIDE COMFORT EVALUATION

According to MIL-F-9490 D the ride comfort at pilot seat is specified for a military aircraft with FCS. The ride comfort criteria for vertical and lateral vibrations are calculated from the PSD of the vibrations and a acceleration weighting function W for a defined v. Karman turbulence spectrum of the gust velocities (Fig. 10). A ride discomfort index D_1 is defined with upper limits, Fig. 11.

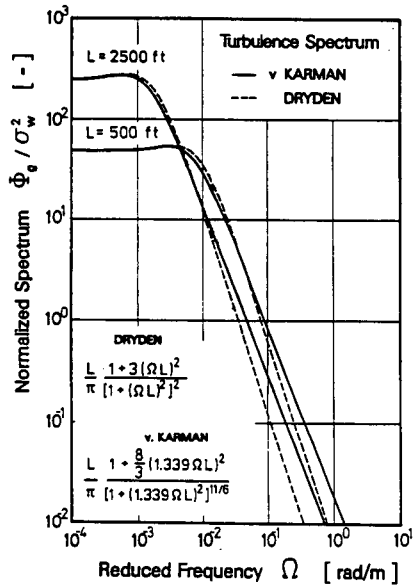

FIG. 10 TURBULENCE SPECTRUM

RIDE COMFORT CRITERIA

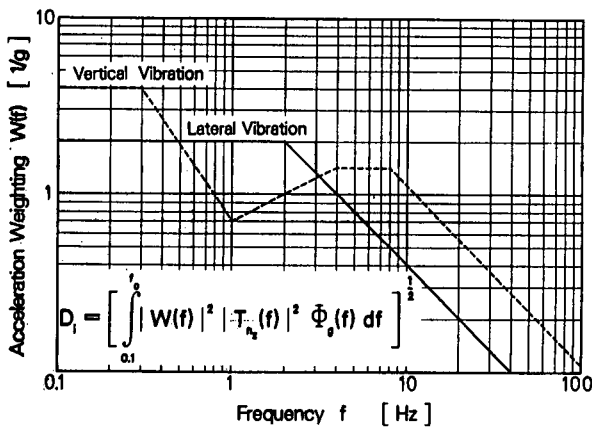

FIG. 11 RIDE DISCOMFORT INDEX

Fig. 12 shows the power spectral density of the investigated aircraft at low level and $Ma = 0.9$, based on a aircraft weight of 11.5 to. The ride discomfort index of the rigid aircraft is $D_1 = 1.2$ which really does not met the requirements.

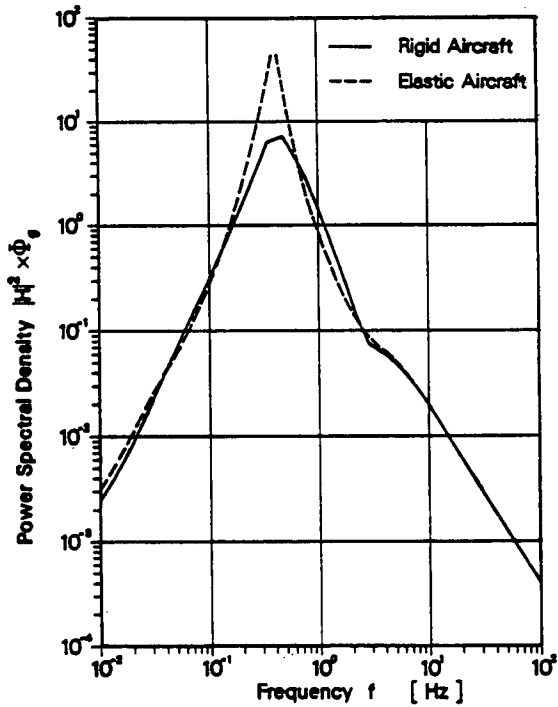

FIG. 12 POWER SPECTRAL DENSITY OF VERTICAL PILOT SEAT ACCELERATION

Another ride comfort evaluation could be based on the criterium of a certain acceleration level exceedance. In Fig. 13 the exceedances of 1/2 g bumps per minute for acceptable to unacceptable ride at low level flight are defined.

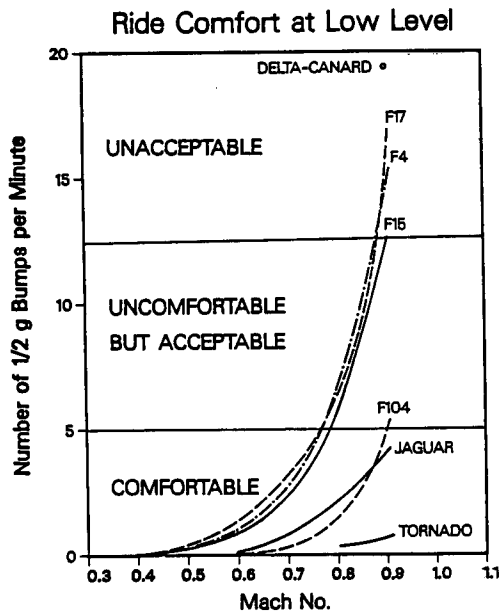

FIG. 13 RIDE COMFORT - EXCEEDANCE OF 1/2 G PER MINUTE AT PILOT SEAT

The exceedance is calculated using the normalised acceleration PSD and RMS value. Rice formula is applied. For the same flight condition this criterium leads also to unacceptable vibration levels for the Delta-Canard configuration at low level, $Ma = 0.9$.

Summary:

Ride comfort requirements are not met for a Delta-Canard-Configuration at low level high speed at low wing loading conditions. Ride improvement systems could be of interest.

STRUCTURAL COUPLING PROBLEMS

A total flexible aircraft with FCS response calculation as described in the previous text would enable the prediction of open and closed loop stability for the coupled flight and structural dynamic modes. Open loop gain and phase margins can be evaluated for all modes including the interdependency. Structural coupling problems which will be of interest especially for originally static unstable configurations can be investigated therefore more accurately.

Fig. 14 shows the Bode diagram of the pitch rate signal of the investigated aircraft with FCS and the effect of notch filtering of the signal on the gain and phase margins in the frequencies of the short period mode and the first two elastic fuselage modes.

GAIN AND PHASE MARGINS

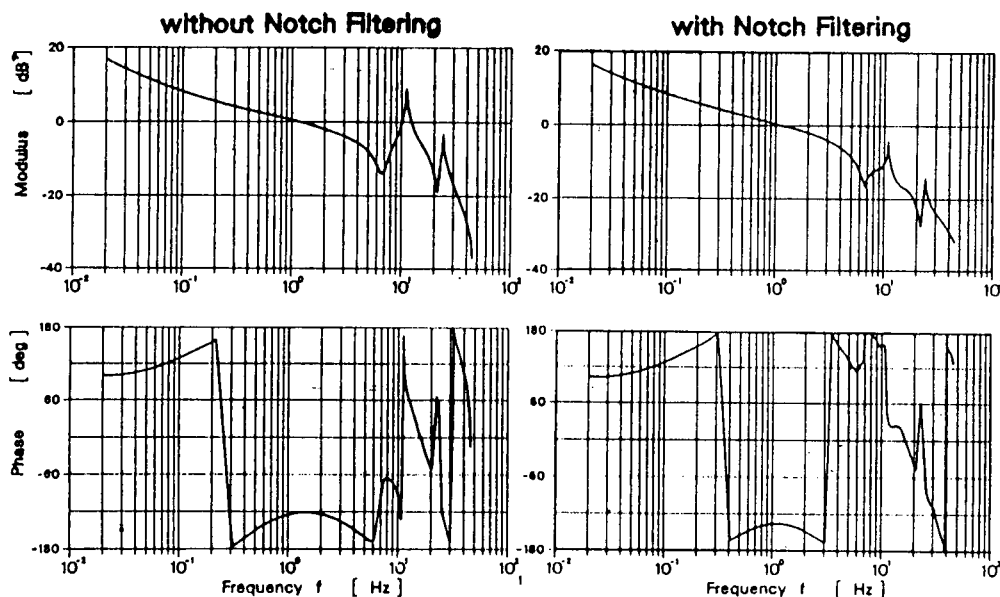

FIG. 14 BODE DIAGRAM OF OPEN LOOP PITCH RATE EFFECT OF NOTCH FILTERING

Summarizing these considerations one can say, that total flexible aircraft response calculations are necessary to predict structural coupling problems of the aircraft with FCS and will help to develop adequate notch filters.

Notch filter design will possibly be even a more pronounced problem for closed loop gust alleviation systems due to higher gains compared to FCS systems.

ACTIVE GUST CONTROL ON FLEXIBLE AIRCRAFT

A ride improvement system or a gust load alleviation system may be based on the principle of incremental gust induced lift and moment compensation (open loop system). Compensation signals to the control surfaces, for instance canard and trailing edge flap deflections δ and η on a fighter aircraft Fig. 15, can formally be evaluated inflight for each condition according to the expression given in Fig. 16.

In order to derive the compensation signals, the gust incidence α_g and its time derivative $\dot{\alpha}_g$ must be measured during flight. The measurement can be performed with flow sensors (α -vanes) or in the future by laser-optical systems. Fig. 17 shows the procedure for the evaluation of the gust incidence from a vane signal, which of course consists of the

combination of gust and aircraft incidence α_{eff} . The gust incidence is extracted using platform signals, the pitch rate and the vertical acceleration.

FEASIBILITY STUDY OF
 ACTIVE GUST CONTROL ON A MILITARY AIRCRAFT

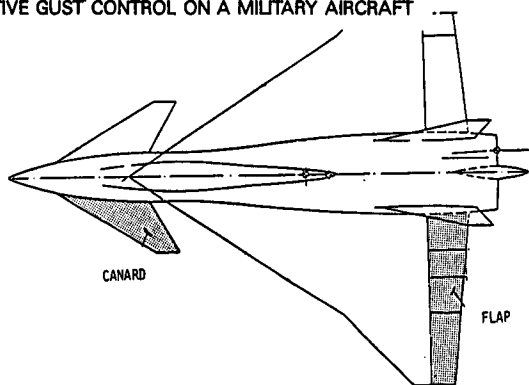

CANARD AND FLAP-ACTUATION FOR THE RIDE IMPROVEMENT SYSTEM
 ON A DELTA CONFIGURATION

FIG. 15 INVESTIGATED AIRCRAFT

$$\begin{Bmatrix} \delta(i\omega) \\ \eta(i\omega) \end{Bmatrix} = \begin{bmatrix} c_{z_\delta}(i\omega) & c_{z_\eta}(i\omega) \\ c_{m_\delta}(i\omega) & c_{m_\eta}(i\omega) \end{bmatrix}^{-1} \begin{bmatrix} c_{z_{\alpha_s}}(i\omega) & \frac{\bar{c}}{\bar{V}} c_{z_{\dot{\alpha}_s}}(i\omega) \\ c_{m_{\alpha_s}}(i\omega) & \frac{\bar{c}}{\bar{V}} c_{m_{\dot{\alpha}_s}}(i\omega) \end{bmatrix} \begin{Bmatrix} \alpha_s(i\omega) \\ \dot{\alpha}_s(i\omega) \end{Bmatrix}$$

FIG. 16 EVALUATION OF COMPENSATION SIGNALS

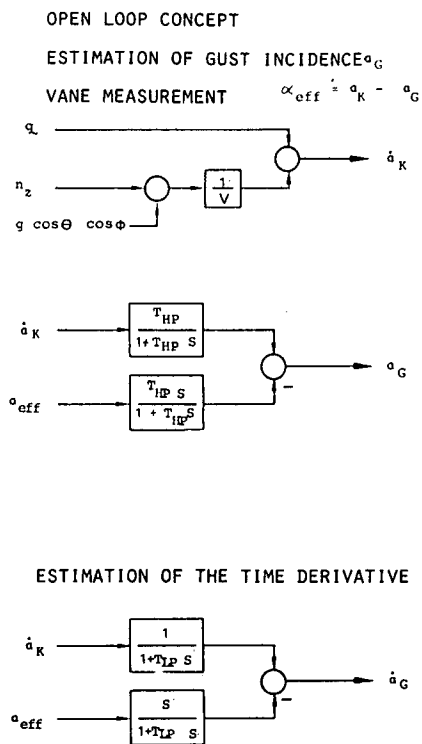

FIG. 17 DERIVATION OF GUST INCIDENCE BY VANE MEASUREMENT

Problems in the successful compensation will arise from the facts:

- contamination of the measured vane signal by aeroelastic deformations at the sensor position and elastic vibrations,
- the applied unsteady aerodynamic derivatives are not accurate enough, especially in transonic flight or due to aeroelastic effects,
- the installed actuator power is not sufficient, the required control surface rates are too high for compensation.

The attractive advantage of an open loop system however consists in its simplicity and in the possibility to develop it separately from the FCS system, since it does not interact with the FCS and does not change the flying qualities.

Ride improvement and gust load alleviation could be achieved also by a closed loop system. In addition to the feedback loop of the FCS system, the pilot seat or vertical acceleration together with pitch rate and pitch acceleration signals can be used to drive the control surfaces to alleviate the gust response or dynamic loads, as demonstrated in the block diagram in Fig. 18.

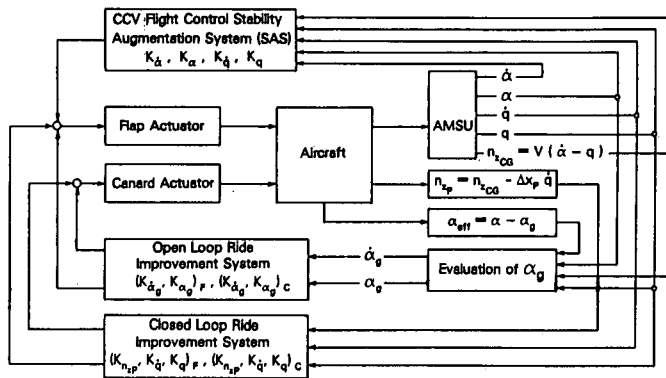

FIG. 18 BLOCK DIAGRAM OF FCS AND GUST ALLEVIATION SYSTEM

The problem areas here will be found in the complexity of the system. The system has to be designed together with the FCS system, because the aircraft stability is affected. The command system must be modified in order to eliminate interaction between the system and pilot command inputs.

In the figures 19, 20 and 21 typical results of the effects of an open and closed loop ride improvement system investigated on a delta-canard are shown. The optimization of the systems was performed by stability analysis of the aircraft and PSD analysis of the C.G. and pilot seat acceleration. The rms pilot seat acceleration and the 1/2 g bumps per minute were minimized with respect to a control surface maximum rate of 50 degrees/sec. Fig. 20 illustrates the changes in short period frequency and damping for different feedback gains and the corresponding peak values of control surfaces rate and deflection. The closed and open loop system provide the same alleviation factor in pilot seat acceleration.

FEEDBACK GAINS				Dryden $\sigma_w = 2. \text{ m/sec (rms)}$								Short period	
$k_{\dot{\alpha}}$ [s]	k_{α} [-]	$k_{\dot{q}}$ [s ²]	k_q [s]	\dot{n}_{cp} [m/s ²]	$\dot{\eta}_c$ [deg/s]	$\dot{\eta}_F$ [deg/s]	η_c [deg]	η_F [deg]	Canard Effi- ciency	ω_n [Hz]	ζ_n		
-1.3	.9	.11	2.	4.7						1.42	5.82		
$k_{\dot{\alpha}}$ [-]	$k_{\dot{\alpha} \dot{\alpha}}$ [-]		K_{Canard} [-]										
.5	.0		1.	3.	51.8	13.4	7.4	1.4	100%				
1.	.0		.5	3.	51.6	13.4	7.4	1.2	100%				
.7	.0		.666	2.8	49.9	17.2	6.9	2.1	+150%				
.7	-2.		.666	2.5	52.1	18.9	6.9	2.1	+150%				

Dryden Spectrum
 $\sigma_w = 2. \text{ m/sec (rms)}$

(M = 0.93; LOW LEVEL)

FIG. 19 EFFECT OF OPEN LOOP RIDE IMPROVEMENT SYSTEM

FEEDBACK GAINS												Short period	
$(k_{n_{zp}})$	k_Q	$k_{\dot{\alpha}_F}$	$(k_{n_{zp}})$	k_Q	$k_{\dot{\alpha}_C}$	n_{zp} [m/s ²]	$\dot{\eta}_C$ [deg/s]	$\dot{\eta}_F$ [deg/s]	η_C [deg]	η_F [deg]	Canard Effi- ciency	ω_n [Hz]	ζ_n
-1	7.5	.6	.011	.0	.0	2.5	53.3	37.8	3.8	.6	100%	1.58	.797
-1	7.5	.55	.0	.0	.07	2.75	55.	48.2	3.4	.4	100%	1.52	.492
-1	7.5	.6	.01	.0	.0	2.4	51.6	37.8	3.4	.6	150%	1.487	.825
-1	7.5	.6	.0	.0	.085	2.55	51.6	51.6	3.4	.6	150%	1.275	.437

(M = 0.93; LOW LEVEL)

FIG. 20 EFFECT OF CLOSED LOOP RIDE IMPROVEMENT SYSTEM

**FEASIBILITY STUDY OF
 ACTIVE GUST CONTROL ON A MILITARY AIRCRAFT
 RIDE IMPROVEMENT INVESTIGATION ON A DELTA-CANARD
 CONFIGURATION (TKF CCV)**

WEIGHT 11500 KG
 TURBULENCE INPUT V.KARMAN SPECTRUM
 RMS VELOCITY = 2.01 M/SEC
 FLIGHT CONDITION MACH=0.93 SEALEVEL
 RESULT : RMS PILOT ACCELERATION IN (G)
 A/C WITH FCS WITHOUT GUST SYSTEM 0.7
 A/C WITH FCS AND OPEN LOOP SYSTEM 0.25
 A/C WITH FCS AND CLOSED LOOP SYSTEM 0.24
 PROBLEMS: CONTROL SURFACE EFFICIENCY AND FLAP RATE
 THE NEEDED FLAP RATE WILL BE ABOUT 100 DEG/SEC
 FOR ELASTIFIED CONTROL SURFACE LIFT AND MOMENT

FIG. 21 RESULTS OF THE RIDE IMPROVEMENT INVESTIGATION

A further example of the effect of a ride improvement system is demonstrated in Fig. 22. The PSD of C.G. acceleration is shown for an transport aircraft flying at cruise condition. High alleviation could be found with a closed loop system (C.G. acceleration feedback), however, the frequency of the short period mode was strongly reduced.

**TRANSPORT AIRPLANE WITH RIDE IMPROVEMENT SYSTEM
 PSD OF C.G. ACCELERATION**

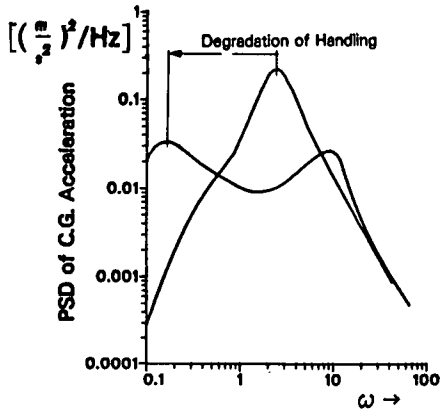

FIG. 22 EFFECT OF A RIDE IMPROVEMENT SYSTEM ON A TRANSPORT AIRCRAFT

An alleviation of vibration levels on this aircraft on all passenger seats could be achieved (Fig. 23). However, without notch filtering of the feedback signal the vibration level are increased with the system in action, which demonstrates the importance of notch filter design.

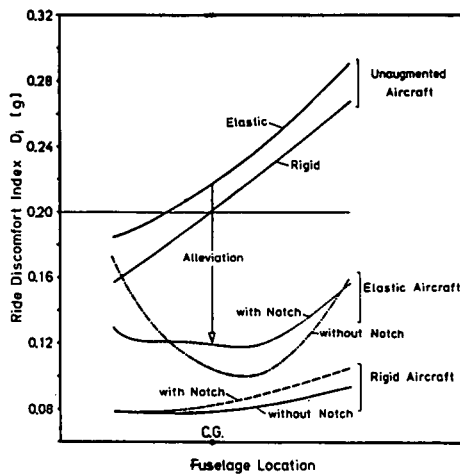

FIG. 23 RIDE DISCOMFORT INDEX ON PASSENGER SEATS OF A TRANSPORT AIRCRAFT

CONCLUSIONS

- A description of fully dynamically coupled flight and structural dynamics of total flexible aircraft is of interest for the prediction of gust loads and for the investigation of gust load alleviation and ride improvement systems. Consequently unsteady motion and gust induced aerodynamic force prediction for the total aircraft will improve accuracy.
- Discrete gust analysis is of importance for military aircraft in the case of configurations with external stores carried on outboard wing stations. High wing dynamic wing loads may be observed.
- Continuous turbulence analysis of aircombat aircraft flying at low level high speed shows unacceptable ride comfort.
- Gust load alleviation systems and ride improvement systems could reduce the problems.
- The systems shall be designed with respect to the aircraft strength and rigidity and aircraft flying quality requirements.
- Realisation of compatibility between load alleviation systems and FCS system is problematic.

REFERENCES

/1/ LASCHKA, B.
 Interfering lifting surfaces in subsonic flow
 Zeitschrift für Flugwissenschaften 18, Heft 9/10, 1970

/2/ RODDEN, W. P.; GIESING, J. P.
 New Developments and Applications of the Subsonic Doublet-Lattice Method for Nonplanar Configurations
 AGARD-CP-No. 80, 1971

/3/ BENNEKERS, B.
 Description of the computer programs for the calculation of aerodynamic loads on oscillating wing-body configuration in subsonic flow (NLRI-Method)
 NLR-TR-76120 C

/4/ ROOS, R.; BENNEKERS, B.; ZWAAN, R. J.
 Calculation on unsteady subsonic flow about harmonically oscillating wing/body configurations
 Journal of Aircraft, Vol. 14, No. 5, May 1977

- /5/ SENSBURG, O., BECKER, J.; LUSEBRINK, H.; WEISS, F.
 Gust Alleviation on Airbus A300 B
 Contribution to the 13th Congress of the International Council of the Aero-
 nautical Sciences (ICAS), Seattle/USA, Aug. 1982
- /6/ BECKER, J.; WEISS, F.; SENSBURG, O.
 Compatibility of active control technologies with aircraft structure design
 Paper presented at the International Symposium on Structural Control -
 University of Waterloo/Ontario (Canada), July 1985
- /7/ BECKER, J.; WEISS, F.; CAVATORTA, E.; CALDARELLI, C.
 Gust Alleviation on a transport airplane
 Paper presented at the FDP-FMP Meeting of AGARD at Göttingen, May 1985

REPORT DOCUMENTATION PAGE											
1. Recipient's Reference	2. Originator's Reference AGARD-R-728	3. Further Reference ISBN 92-835-1532-3	4. Security Classification of Document UNCLASSIFIED								
5. Originator	Advisory Group for Aerospace Research and Development North Atlantic Treaty Organization 7 rue Ancelle, 92200 Neuilly sur Seine, France										
6. Title	GUST LOAD PREDICTION AND ALLEVIATION ON A FIGHTER AIRCRAFT										
7. Presented at	the 61st Meeting of the Structures and Materials Panel of AGARD in Oberammergau, Germany on 8-13 September 1985.										
8. Author(s)/Editor(s)	Becker, J.		9. Date Dec 1986								
10. Author's/Editor's Address	Messerschmitt-Bölkow-Blohm GmbH Munich, Federal Republic of Germany		11. Pages 22								
12. Distribution Statement	This document is distributed in accordance with AGARD policies and regulations, which are outlined on the Outside Back Covers of all AGARD publications.										
13. Keywords/Descriptors	<table border="0"> <tr> <td>Aerodynamic loads</td> <td>Turbulence</td> </tr> <tr> <td>Aerodynamic stability</td> <td>Dynamic structural analysis</td> </tr> <tr> <td>Aeroelasticity</td> <td>Fighter aircraft</td> </tr> <tr> <td>Gusts</td> <td></td> </tr> </table>			Aerodynamic loads	Turbulence	Aerodynamic stability	Dynamic structural analysis	Aeroelasticity	Fighter aircraft	Gusts	
Aerodynamic loads	Turbulence										
Aerodynamic stability	Dynamic structural analysis										
Aeroelasticity	Fighter aircraft										
Gusts											
14. Abstract	<p>In 1985 the Structures and Materials Panel initiated an activity on the flight of flexible aircraft in turbulence. As a preliminary the Panel heard this paper which discusses the influence of turbulence — induced dynamic loads on the structural design of fighter aircraft. Methods for calculating dynamic response are given, and the problems associated with improved ride are considered.</p>										

<p>AGARD Report No.728 Advisory Group for Aerospace Research and Development, NATO GUSTLOAD PREDICTION AND ALLEVIATION ON A FIGHTER AIRCRAFT by J.Becker Published June 1986 22 pages</p> <p>In 1985 the Structures and Materials Panel initiated an activity on the flight of flexible aircraft in turbulence. As a preliminary the Panel heard this paper which discusses the influence of turbulence — induced dynamic loads on the structural design of fighter aircraft. Methods for calculating dynamic response are given, and the problems associated with improved ride are considered.</p> <p style="text-align: right;">P.T.O</p>	<p style="text-align: center;">AGARD-R-728</p> <p>Aerodynamic loads Aerodynamic stability Aeroelasticity Gusts Turbulence Dynamic structural analysis Fighter aircraft</p>	<p>AGARD Report No.728 Advisory Group for Aerospace Research and Development, NATO GUSTLOAD PREDICTION AND ALLEVIATION ON A FIGHTER AIRCRAFT by J.Becker Published June 1986 22 pages</p> <p>In 1985 the Structures and Materials Panel initiated an activity on the flight of flexible aircraft in turbulence. As a preliminary the Panel heard this paper which discusses the influence of turbulence — induced dynamic loads on the structural design of fighter aircraft. Methods for calculating dynamic response are given, and the problems associated with improved ride are considered.</p> <p style="text-align: right;">P.T.O</p>	<p style="text-align: center;">AGARD-R-728</p> <p>Aerodynamic loads Aerodynamic stability Aeroelasticity Gusts Turbulence Dynamic structural analysis Fighter aircraft</p>
<div style="background-color: black; width: 100%; height: 100%;"></div>	<p>AGARD Report No.728 Advisory Group for Aerospace Research and Development, NATO GUSTLOAD PREDICTION AND ALLEVIATION ON A FIGHTER AIRCRAFT by J.Becker Published June 1986 22 pages</p> <p>In 1985 the Structures and Materials Panel initiated an activity on the flight of flexible aircraft in turbulence. As a preliminary the Panel heard this paper which discusses the influence of turbulence — induced dynamic loads on the structural design of fighter aircraft. Methods for calculating dynamic response are given, and the problems associated with improved ride are considered.</p> <p style="text-align: right;">P.T.O</p>	<p style="text-align: center;">AGARD-R-728</p> <p>Aerodynamic loads Aerodynamic stability Aeroelasticity Gusts Turbulence Dynamic structural analysis Fighter aircraft</p>	

Paper presented at the 61st Meeting of the Structures and Materials Panel of AGARD in Oberammergau, Germany on 8–13 September 1985.

ISBN 92-835-1532-3

Paper presented at the 61st Meeting of the Structures and Materials Panel of AGARD in Oberammergau, Germany on 8–13 September 1985.

ISBN 92-835-1532-3

Paper presented at the 61st Meeting of the Structures and Materials Panel of AGARD in Oberammergau, Germany on 8–13 September 1985.

ISBN 92-835-1532-3

AGARD

NATO  OTAN

7 RUE ANCELLE · 92200 NEUILLY-SUR-SEINE

FRANCE

Telephone (1) 47.45.08.10 · Telex 610176

DISTRIBUTION OF UNCLASSIFIED

AGARD PUBLICATIONS

AGARD does NOT hold stocks of AGARD publications at the above address for general distribution. Initial distribution of AGARD publications is made to AGARD Member Nations through the following National Distribution Centres. Further copies are sometimes available from these Centres, but if not may be purchased in Microfiche or Photocopy form from the Purchase Agencies listed below.

NATIONAL DISTRIBUTION CENTRES

BELGIUM

Coordonnateur AGARD — VSL
Etat-Major de la Force Aérienne
Quartier Reine Elisabeth
Rue d'Evere, 1140 Bruxelles

CANADA

Defence Scientific Information Services
Dept of National Defence
Ottawa, Ontario K1A 0K2

DENMARK

Danish Defence Research Board
Ved Idraetsparken 4
2100 Copenhagen Ø

FRANCE

O.N.E.R.A. (Direction)
29 Avenue de la Division Leclerc
92320 Châtillon

GERMANY

Fachinformationszentrum Energie,
Physik, Mathematik GmbH
Kernforschungszentrum
D-7514 Eggenstein-Leopoldshafen

GREECE

Hellenic Air Force General Staff
Research and Development Directorate
Holargos, Athens

ICELAND

Director of Aviation
c/o Flugrad
Reyjavik

ITALY

Aeronautica Militare
Ufficio del Delegato Nazionale all'AGARD
3 Piazzale Adenauer
00144 Roma/EUR

LUXEMBOURG

See Belgium

NETHERLANDS

Netherlands Delegation to AGARD
National Aerospace Laboratory, NLR
P.O. Box 126
2600 AC Delft

NORWAY

Norwegian Defence Research Establishment
Attn: Biblioteket
P.O. Box 25
N-2007 Kjeller

PORTUGAL

Portuguese National Coordinator to AGARD
Gabinete de Estudos e Programas
CLAFAP
Base de Alfragide
Alfragide
2700 Amadora

TURKEY

Department of Research and Development (ARGE)
Ministry of National Defence, Ankara

UNITED KINGDOM

Defence Research Information Centre
Kentigern House
65 Brown Street
Glasgow G2 8EX

UNITED STATES

National Aeronautics and Space Administration (NASA)
Langley Research Center
M/S 180
Hampton, Virginia 23665

THE UNITED STATES NATIONAL DISTRIBUTION CENTRE (NASA) DOES NOT HOLD STOCKS OF AGARD PUBLICATIONS, AND APPLICATIONS FOR COPIES SHOULD BE MADE DIRECT TO THE NATIONAL TECHNICAL INFORMATION SERVICE (NTIS) AT THE ADDRESS BELOW.

PURCHASE AGENCIES

Microfiche or Photocopy

National Technical
Information Service (NTIS)
5285 Port Royal Road
Springfield
Virginia 22161, USA

Microfiche

ESA/Information Retrieval Service
European Space Agency
10, rue Mario Nikis
75015 Paris, France

Microfiche or Photocopy

British Library Lending
Division
Boston Spa, Wetherby
West Yorkshire LS23 7BQ
England

Requests for microfiche or photocopies of AGARD documents should include the AGARD serial number, title, author or editor, and publication date. Requests to NTIS should include the NASA accession report number. Full bibliographical references and abstracts of AGARD publications are given in the following journals:

Scientific and Technical Aerospace Reports (STAR)
published by NASA Scientific and Technical
Information Branch
NASA Headquarters (NIT-40)
Washington D.C. 20546, USA

Government Reports Announcements (GRA)
published by the National Technical
Information Services, Springfield
Virginia 22161, USA



Printed by Specialised Printing Services Limited
40 Chigwell Lane, Loughton, Essex IG10 3TZ

ISBN 92-835-1532-3