

NOTICE: When Government drawings, specifications, or other data are used for any purpose other than in connection with a definitely related Government procurement operation, the United States Government thereby incurs no responsibility, nor any obligation whatsoever; and it is expressly understood that the use of such drawings, specifications, or other data is not to be regarded by implication or otherwise as in any manner licensing or authorizing the Government to reproduce, to disseminate, or to convey any rights or permissions to manufacturer, use, or sell any patented invention that may in any way be related thereto.

NOTE: This drawing was approved by joint action of the War and Navy Departments as the Army-Navy Standard Drawing for the same product and shall become effective for the procurement of non-aeronautical supplies, or for use in Army design, not later than six months after the latest date of approval appears. It may be put into effect, however, at an earlier date after presentation.

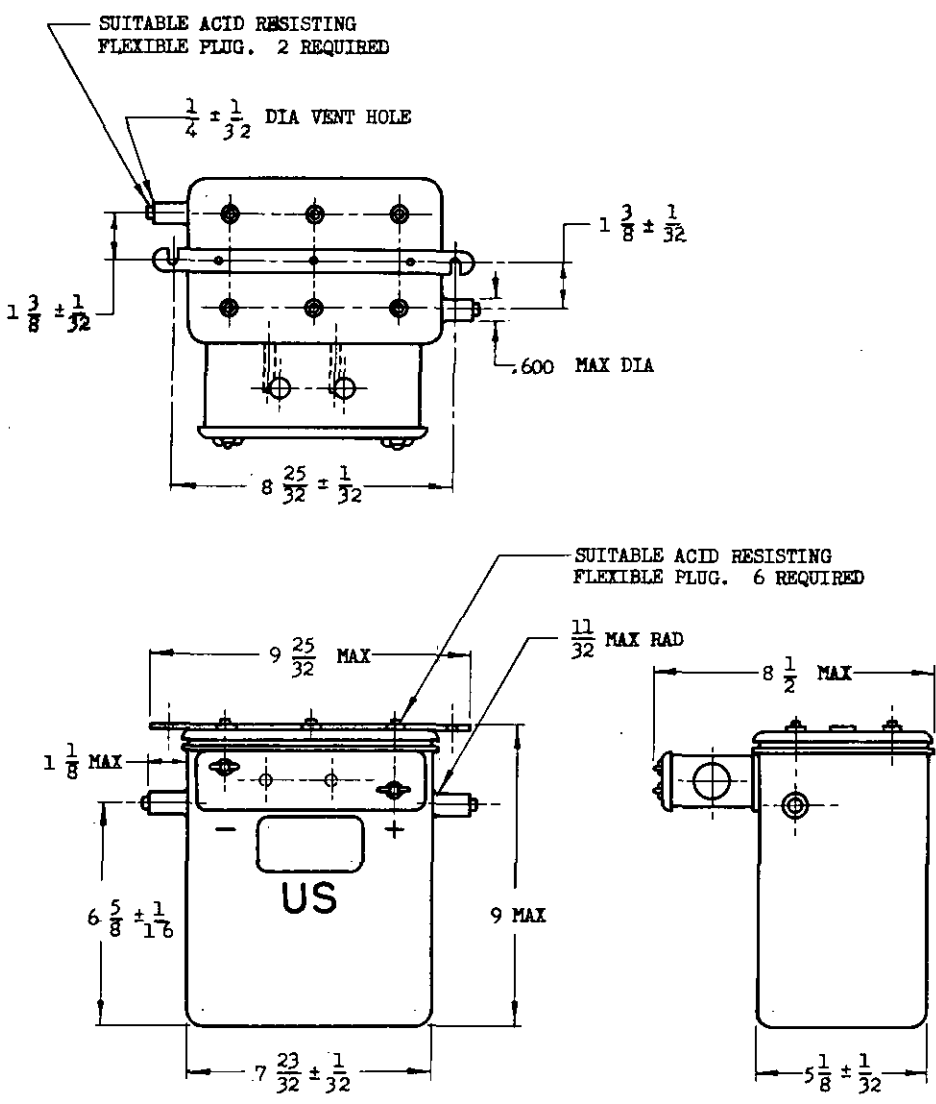

③ CANCELED AFTER 17 JANUARY 1969.
 NO SUPERSEDING STANDARD.

| |
|---------------|
| AN PART NO. |
| (a) AN3153-1A |

(a) PREVIOUS PART NUMBER AN3153-1 INACTIVE FOR NEW PROCUREMENT. PART NUMBER AN3153-1A REPLACES AND IS INTERCHANGEABLE WITH PART NUMBER AN3153-1.

WEIGHT: 29.5 LBS MAXIMUM.
 DIMENSIONS IN INCHES.

| | | |
|--------------------------------------|---|--------|
| PROCUREMENT SPECIFICATION AN-B-13 | ARMY-NAVY AERONAUTICAL STANDARD | AN3153 |
| | BATTERY-12 VOLT 17 AMPERE HOUR SHIELDED STORAGE | |

APPROVED 8 May 43 REVISED 1 25 Sep 43 ② 11 Apr 46 ③ 17 Jan 69