

ARMY - MI, HE  
NAVY  
AIR FORCE

ARMY  
NAVY  
AIR FORCE  
DLA - IS

This military standard is approved for use by all Departments and Agencies of the Department of Defense. Selection for all new engineering and design applications and for repetitive use shall be made from this document.

FED SUP CLASS  
5305

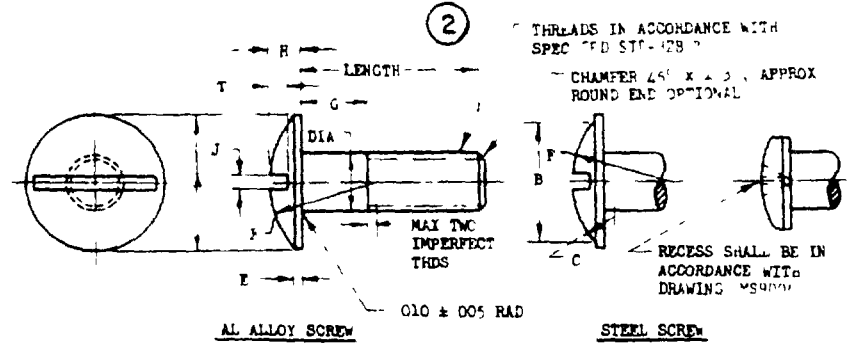

SIZE	DIA + .000 - .002	A DIA	B DIA	C RAD	E + .005 - .000	F RAD	H ± .005	J	T ± .005
164-32UNC-3A	164	375	312	078	023	312	087	043 + .007 - .006	049
164-36UNF-3A									
190-32UNF-3A	.190	437	375	078	025	398	094	047 ± .008 - .006	054
250-28UNF-3A	250	500	437	097	028	474	101	053 ± .008 - .007	058

DASH NOS FOR SLOTTED HEAD STEEL SCREWS

LENGTH ± 1/32	G	DASH NUMBERS				LENGTH ± 1/32	G	DASH NUMBERS			
		#8-32	#8-36	#10-32	1/4-28			#8-32	#8-36	#10-32	1/4-28
						1-1/8	23/32	832-18	8-18	10-18	416-18
3/8	1/32	832-6	8-6	10-6	416-6	1-1/4	27/32	832-20	8-20	10-20	416-20
7/16	1/16	832-7	8-7	10-7	416-7	1-3/8	31/32	832-22	8-22	10-22	416-22
1/2	1/8	832-8	8-8	10-8	416-8	1-1/2	1-3/32	832-24	8-24	10-24	416-24
9/16	5/32	832-9	8-9	10-9	416-9	1-5/8	1-7/32	832-26	8-26	10-26	416-26
5/8	7/32	832-10	8-10	10-10	416-10	1-3/4	1-11/32	832-28	8-28	10-28	416-28
11/16	9/32	832-11	8-11	10-11	416-11	1-7/8	1-15/32	832-30	8-30	10-30	416-30
3/4	11/32	832-12	8-12	10-12	416-12	2	1-19/32	832-32	8-32	10-32	416-32
7/8	15/32	832-14	8-14	10-14	416-14						
1	19/32	832-16	8-16	10-16	416-16						

- MATERIAL STEEL SPEC AMS 6300 OR MIL-S-6050 TENSILE STRENGTH 125 000 PSI (MIN)  
AL ALLOY QQ-A-700/5 TENSILE STRENGTH 62 000 PSI (MIN)
- FINISH STEEL CAP PLATE SPEC QQ-P-416 TYPE II CLASS 1 OR ZINC PLATE  
PER ASTM B 633-78 Fe/Zn 13 TYPE II
- PART NUMBERS ADD R BETWEEN FIRST AND SECOND DASH NOS FOR RECESSED HEAD SCREWS  
ADD "D" BEFORE FIRST DASH NUMBER FOR AL ALLOY SCREWS SIZE R AVAILABLE WITH MC THREAD ONLY  
EXAMPLE OF PART NO AN525-10-6 = 190-32 SLOTTED HEAD STEEL SCREW 3/8 LONG WITH 1/32 CRIP  
AN525D10-6 = 190-32 SLOTTED HEAD AL ALLOY SCREW 3/8 LONG WITH 1/32 CRIP  
AN525-10R6 = 190-32 RECESSED HEAD STEEL SCREW 3/8 LONG WITH 1/32 GRIP
- BEARING SURFACE OF HEAD MUST BE FREE FROM BURRS AND TOOL MARKS
- DIMENSIONS IN INCHES UNLESS OTHERWISE SPECIFIED TOLERANCES FRACTIONS ± 1/64 DECIMALS ± 0.10 ANGLES ± .05
- REFERENCED DOCUMENTS SHALL BE OF THE ISSUE IN EFFECT ON DATE OF INVITATIONS FOR BIDS OR REQUEST FOR PROPOSAL EXCEPT THAT REFERENCED ADOPTED INDUSTRY DOCUMENTS SHALL CITE THE DATE OF THE ISSUE ADOPTED
- FOR DESIGN FEATURE PURPOSES THIS STANDARD TAKES PRECEDENCE OVER PROCUREMENT DOCUMENTS REFERENCED HEREIN

APPROVED 29 OCT 45 REVISED 1 27 SEP 63 29 JAN 85

P A AIR FORCE - 82 Other Code AIR FORCE - 99 NAVY - AS	INTERNATIONAL INTEREST	SCREW - WASHER HEAD	AN525
PROCUREMENT SPECIFICATION MIL-S-7839	SUPERSEDES	SHEET	OF

DD FORM 672-1 (COORDINATED)

PREVIOUS EDITIONS OF THIS FORM ARE OBSOLETE

INCH-POUND

AN525 REV. 2  
AMENDMENT 1  
20 May 1996

AIR FORCE - NAVY AERONAUTICAL STANDARD

SCREW, WASHER HEAD

This amendment forms a part of AN525 REV. 2, dated , 29 January 1985 and is approved for use by all Departments and Agencies of the Department of Defense.

PAGE 1

Material: delete: "QQ-A-200/5" and substitute: "ASTM B221, B241, or B308".

Custodians:

Army - AV  
Navy - AS  
Air Force - 99

Preparing Activity:

DLA-IS  
(Project 5305-2132)

AMSC N/A

FSC 5305

DISTRIBUTION STATEMENT A. Approved for public release; distribution is unlimited