

INCH-POUND

AN6204K
 w/AMENDMENT 1
 25 May 2006
 SUPERSEDING
 AN6204K
 25 January 2006

DETAIL SPECIFICATION SHEET

VALVE, HYDRAULIC BLEEDER

This specification is approved for use by all Departments and Agencies of the Department of Defense.

The requirements for acquiring the product described herein shall consist of this specification sheet.

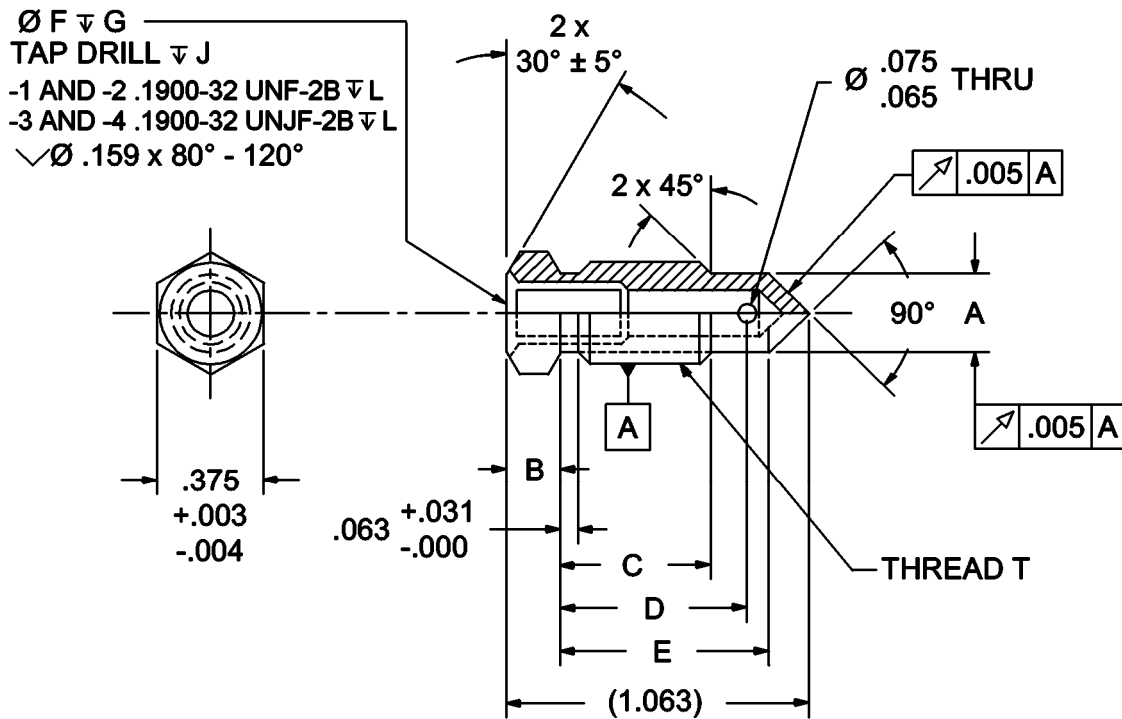

FIGURE 1. Valve dimensions and configuration.

AN6204K
 w/AMENDMENT 1

| AN6204 Dash number | Thread T | A Dia | B ±.016 | C ±.016 | D ±.016 | E ±.016 | F | G ±.016 | J ±.016 | L ±.016 |
|--------------------|-----------------------------|--------------------------|---------|---------|---------|---------|-------|--------------------------|---------|---------|
| 1 <u>1</u> / | .3750-24 UNF-2A <u>2</u> / | .278 | .188 | .563 | .656 | .734 | .159 | .906 | --- | --- |
| 2 <u>1</u> / | .2500-28 UNF-2A <u>2</u> / | +0.000 .190 -0.005 | .430 | .406 | .453 | .531 | .0781 | +0.000 .922 -0.010 | .344 | .313 |
| 3 <u>3</u> / | .3750-24 UNJF-2A <u>4</u> / | .278 | .188 | .563 | .656 | .734 | .159 | .906 | --- | --- |
| 4 <u>3</u> / | .2500-28 UNJF-2A <u>4</u> / | +0.000 .190 -0.005 | .430 | .406 | .453 | .531 | .0781 | +0.000 .922 -0.010 | .344 | .313 |

- 1/ Inactive for new design.
- 2/ Thread right hand in accordance with ASME B1.1.
- 3/ Recommended for new design.
- 4/ Thread right hand in accordance with SAE AS8879.

| Inches | mm | Inches | mm |
|--------|-------|--------|-------|
| .003 | 0.08 | .2500 | 6.350 |
| .004 | 0.10 | .278 | 7.06 |
| .005 | 0.13 | .313 | 7.95 |
| .010 | 0.25 | .344 | 8.74 |
| .016 | 0.41 | .375 | 9.53 |
| .031 | 0.79 | .3750 | 9.525 |
| .063 | 1.60 | .406 | 10.31 |
| .065 | 1.65 | .430 | 10.92 |
| .075 | 1.91 | .531 | 13.49 |
| .0781 | 1.984 | .563 | 14.30 |
| .159 | 4.04 | .734 | 18.64 |
| .188 | 4.78 | .906 | 23.01 |
| .190 | 4.83 | .922 | 23.42 |
| | | 1.063 | 27.00 |

NOTES:

1. Dimensions are in inches.
2. Metric equivalents are given for information only.
3. Unless otherwise specified, tolerances ± .005 (0.13 mm), angles ± .5°.
4. Dimensioning and tolerancing in accordance with ASME Y14.5.
5. Break edges .003 inch to .015 inch (0.08 to 0.38 mm) unless otherwise specified. Remove all hanging burrs and slivers.
6. Surface texture shall be 250 μin R_a for unmachined surfaces, except forging parting lines and 500 μin R_a for forging parting planes in accordance with ASME B46.1.

FIGURE 1. Valve dimensions and configuration - Continued.

AN6204K
w/AMENDMENT 1

REQUIREMENTS:

Materials:

Steel alloy 4140 in accordance with SAE AMS 6349 or SAE AMS 6382.
Stainless steel in accordance with one of the following:

- Alloy 321 in accordance with SAE AMS 5645.
- SAE AMS 5862.
- Alloy 15-5 PH in accordance with SAE AMS 5659.
- Alloy UNS S1500 in accordance with ASTM A693, or ASTM A705/A705M.

Heat treat to 155,000 psi (1068.68 megapascal) tensile strength.

Finish:

Steel - Cadmium in accordance with SAE AMS-QQ-P-416, type II, class 2, dyed black.
Stainless steel - No finish.

Operating characteristics.

The valve shall be able to withstand and seal 2,250 psi (15.51 megapascal) minimum pressure.

Part or Identifying Number (PIN):

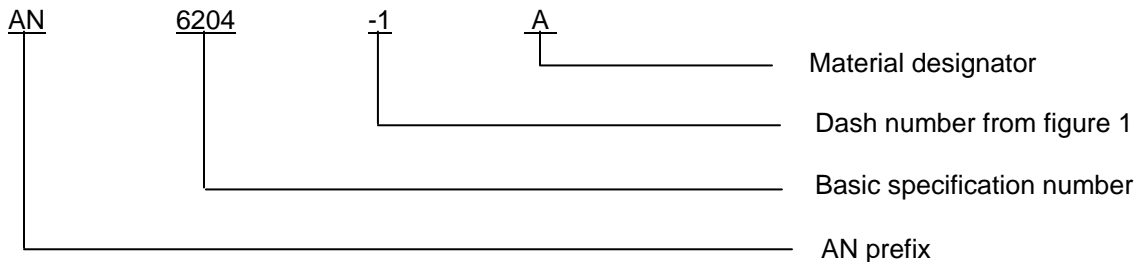

Material designators:

- A - Steel alloy 4140 with cadmium finish.
- B - Stainless steel no finish.

Guidance on use of alternative parts with less hazardous or non-hazardous materials. This specification provides for a number of alternative plating materials via the PIN. Users should select the PIN with the least hazardous material that meets the form, fit, and function requirements of their application.

Amendment notations. The margins of this specification are marked with vertical lines to indicate where modifications from this amendment were made. This was done as a convenience only and the Government assumes no liability whatsoever for any inaccuracies in this notations. Bidders and contractors are cautioned to evaluate the requirements of this document based on the entire content irrespective of the marginal notations.

AN6204K
w/AMENDMENT 1

Referenced documents: This document references the following:

| | |
|-----------------|------------------|
| ASME B1.1 | SAE AMS 5645 |
| ASME B46.1 | SAE AMS 5659 |
| ASME Y14.5. | SAE AMS 5862 |
| ASTM A693 | SAE AMS 6349 |
| ASTM A705/A705M | SAE AMS 6382 |
| SAE AS8879 | SAE AMS-QQ-P-416 |

CONCLUDING MATERIAL

Custodians:

Army - AV
Navy - AS
Air Force - 99
DLA - CC

Preparing activity:

DLA - CC

(Project 4820-2006-003)

Review activities:

Army - MI
Navy - CG, MC, SA, SH
Air Force - 11, 70, 71

NOTE: The activities listed above were interested in this document as of the date of this document. Since organizations and responsibilities can change, you should verify the currency of the information above using the ASSIST Online database at <http://assist.daps.dla.mil>.