

INCH-POUND

AN912 Rev 10
19 July 2011
SUPERSEDING
AN912 Rev 9
21 March 1979

DETAIL SPECIFICATION SHEET

BUSHING, PIPE

Reinstated after 19 July 2011. Inactive for new design.
For new design, use SAE-AS4861.

This specification is approved for use by all Departments and
Agencies of the Department of Defense.

The requirements for acquiring the product described herein shall consist of this specification sheet and
SAE-AS4842.

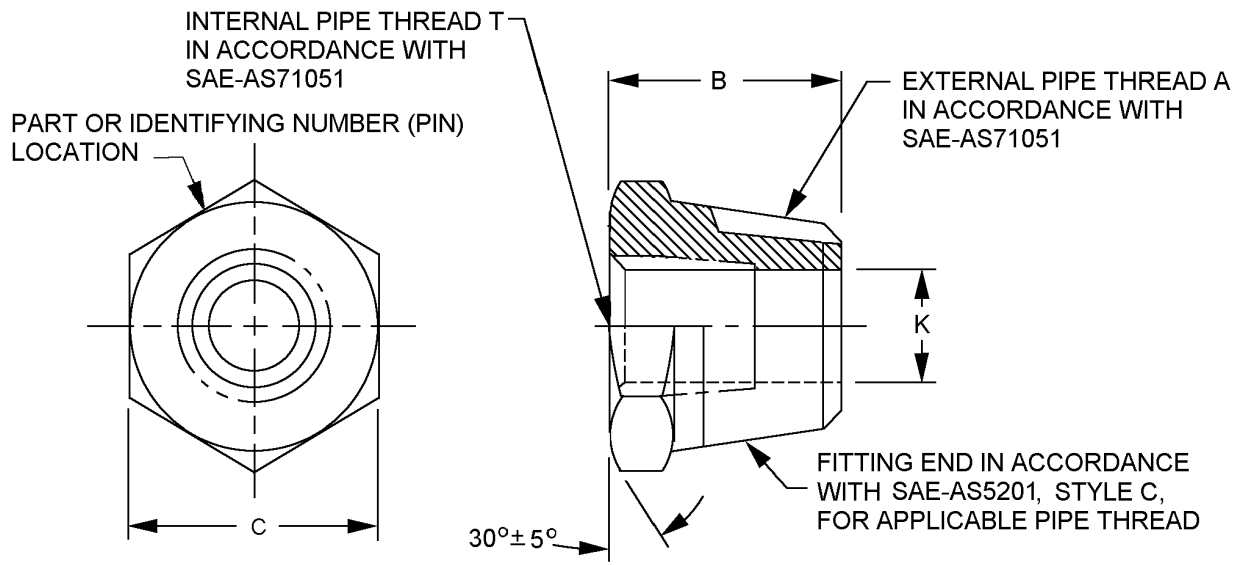

FIGURE 1. Bushing dimensions and configurations.

AN912 Rev 10

Dash number	A Pipe thread ANPT SAE-AS71051		T Pipe thread ANPT SAE-AS71051	
	External	SAE-AS5201 size code	Internal	SAE-AS5201 size code
1	1/4-18	04	1/8-27	02
2	3/8-18	06	1/4-18	04
3	3/8-18	06	1/8-27	02
4	1/2-14	08	3/8-18	06
5	1/2-14	08	1/4-18	04
6	1/2-14	08	1/8-27	02
7	3/4-14	12	1/2-14	08
8	3/4-14	12	3/8-18	06
9	3/4-14	12	1/4-18	04
10	1-11 1/2	16	3/4-14	12
11	1-11 1/2	16	1/2-14	08
12	1-11 1/2	16	3/8-18	06
13	1 1/4-11 1/2	20	3/4-14	12

B ±.031 (0.79) inches (mm)	C inches (mm)	
.781 (19.84)	.625 (15.88)	±.004 (0.10)
.781 (19.84)	.750 (19.05)	±.004 (0.10)
.781 (19.84)	.750 (19.05)	±.004 (0.10)
1.016 (25.81)	.937 (23.80)	±.004 (0.10)
1.016 (25.81)	.937 (23.80)	±.004 (0.10)
1.016 (25.81)	.937 (23.80)	±.004 (0.10)
1.063 (27.00)	1.125 (28.58)	±.005 (0.13)
1.063 (27.00)	1.125 (28.58)	±.005 (0.13)
1.063 (27.00)	1.125 (28.58)	±.005 (0.13)
1.250 (31.75)	1.375 (34.93)	±.005 (0.13)
1.250 (31.75)	1.375 (34.93)	±.005 (0.13)
1.250 (31.75)	1.375 (34.93)	±.005 (0.13)
1.281 (32.54)	1.750 (44.45)	±.016 (0.41)

FIGURE 1. Bushing dimensions and configurations- Continued.

AN912 Rev 10

Dash number	K Dia. inches (mm)		Weight max lbs (kg)			
			Copper alloy	Al alloy	Steel, CRES	Ti alloy
1	.327 (8.31)	+0.000 -0.016 (0.41)	.033 (0.015)	.011 (0.005)	.033 (0.015)	.018 (0.008)
2	.423 (10.74)	+0.000 -0.019 (0.48)	.048 (0.022)	.016 (0.007)	.048 (0.022)	.026 (0.012)
3	.327 (8.31)	+0.000 -0.016 (0.41)	.063 (0.029)	.021 (0.010)	.063 (0.029)	.035 (0.016)
4	.557 (14.15)	+0.000 -0.028 (0.71)	.090 (0.041)	.030 (0.014)	.090 (0.041)	.050 (0.023)
5	.423 (10.74)	+0.000 -0.019 (0.48)	.123 (0.056)	.041 (0.019)	.123 (0.056)	.068 (0.031)
6	.327 (8.31)	+0.000 -0.016 (0.41)	.144 (0.065)	.048 (0.022)	.144 (0.065)	.079 (0.036)
7	.688 (17.48)	+0.000 -0.034 (0.86)	.144 (0.065)	.048 (0.022)	.144 (0.065)	.079 (0.036)
8	.557 (14.15)	+0.000 -0.028 (0.71)	.195 (0.088)	.065 (0.029)	.195 (0.088)	.107 (0.048)
9	.423 (10.74)	+0.000 -0.019 (0.48)	.288 (0.131)	.076 (0.034)	.228 (0.103)	.126 (0.057)
10	.897 (22.78)	+0.000 -0.040 (1.02)	.246 (0.112)	.082 (0.037)	.246 (0.112)	.136 (0.062)
11	.688 (17.48)	+0.000 -0.034 (0.86)	.339 (0.154)	.113 (0.051)	.338 (0.153)	.187 (0.085)
12	.557 (14.15)	+0.000 -0.028 (0.71)	.402 (0.182)	.134 (0.061)	.401 (0.182)	.221 (0.103)
13	.897 (22.78)	+0.000 -0.040 (1.02)	.576 (0.261)	.192 (0.087)	.575 (0.261)	.317 (0.144)

NOTES:

1. Dimensions are in inches.
2. Metric equivalents are given for information only.
3. Break sharp edges .and remove all hanging burrs and slivers
4. Machined surfaces shall be finished to 125µin Ra, forged surfaces shall be 250µin Ra, unless otherwise specified on the figures. Surface finish shall be in accordance with ASME B46.1.
5. For design features purposes, this standard takes precedence over documents referenced herein.
6. Referenced documents shall be of the issue in effect on date of invitation for bid.

FIGURE 1. Bushing dimensions and configurations - Continued.

REQUIREMENTS:

Dimensions and configuration shall be in accordance with figure 1.

Materials and finishes shall be in accordance with SAE-AS4842, see table I for material code.

AN912 Rev 10

TABLE I. Material and code letters.

Code letter	Material
Blank	Copper alloy
J	Corrosion resistant steel (CRES), type 304
K	CRES, type 316
R	CRES. Type 321
T <u>1/</u>	Titanium alloy
W	Aluminum alloy 7075-T73

1/ Not for use in oxygen systems.

Part or Identifying Number (PIN): The PIN consists of prefix “AN” the specification sheet number, a dash number for pipe size, and material code letter. Unassigned PIN’s shall not be used.

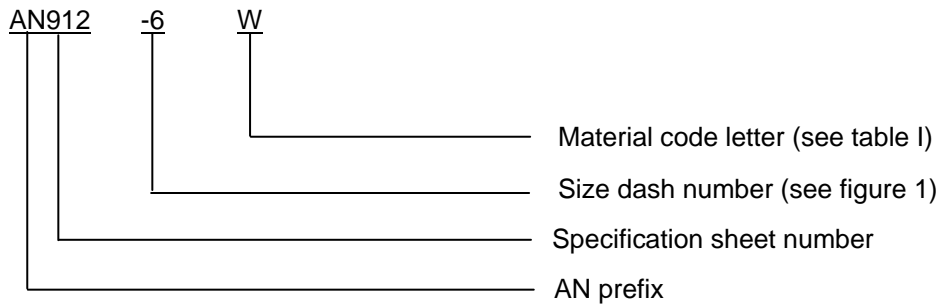

PIN example: AN912-6W indicates a bushing .500 inch (12.70 mm) pipe threads external and .125 inch (3.18 mm) pipe threads internal, aluminum alloy 7075-T73.

Supersession data:

Due to stress corrosion cracking aluminum alloys 2014 and 2024 “D” designator has been replaced by aluminum alloy 7075 “W” designator. Example: AN912-8D use AN912-8W.

Metal cracking due to high temperatures CRES alloy 347 “S” designator has been replaced by CRES alloy 321 “R” designator. Example: AN912-8S use AN912-8R.

Marking: Part shall be permanently marked with the AN PIN, and include the manufacturers CAGE, name, or trademark.

Table II provides a detailed cross-reference of AN912 PINs and replacement SAE-AS4861 PINs. Users are cautioned to evaluate replacements for their particular application.

CAUTION: The superseding information is valid as of the date of this specification and may be superseded by subsequent revisions of the superseding document.

AN912 Rev 10

TABLE II. Cross-reference data.

AN PIN (inactive)	Pipe size	Replacement AS PIN (for new design)	Replacement AN PIN (inactive)
AN912-1	.250	AS4861-01	
AN912-1D	.250	AS4861W01	AN912-1W
AN912-1J	.250	AS4861J01	
AN912-1K	.250	AS4861K01	
AN912-1R	.250	AS4861R01	
AN912-1S	.250	AS4861R01	AN912-1R
AN912-1T	.250	None	
AN912-1W	.250	AS4861W01	
AN912-2	.375	AS4861-02	
AN912-2D	.375	AS4861W02	AN912-2W
AN912-2J	.375	AS4861J02	
AN912-2K	.375	AS4861K02	
AN912-2R	.375	AS4861R02	
AN912-2S	.375	AS4861R02	AN912-2R
AN912-2T	.375	None	
AN912-2W	.375	AS4861W02	
AN912-3	.375	AS4861-03	
AN912-3D	.375	AS4861W03	AN912-3W
AN912-3J	.375	AS4861J03	
AN912-3K	.375	AS4861K03	
AN912-3R	.375	AS4861R03	
AN912-3S	.375	AS4861R03	AN912-3R
AN912-3T	.375	None	
AN912-3W	.375	AS4861W03	
AN912-4	.500	AS4861-04	
AN912-4D	.500	AS4861W04	AN912-4W
AN912-4J	.500	AS4861J04	
AN912-4K	.500	AS4861K04	
AN912-4R	.500	AS4861R04	
AN912-4S	.500	AS4861R04	AN912-4R
AN912-4T	.500	None	
AN912-4W	.500	AS4861W04	
AN912-5	.500	AS4861-05	
AN912-5D	.500	AS4861W05	AN912-5W
AN912-5J	.500	AS4861J05	
AN912-5K	.500	AS4861K05	
AN912-5R	.500	AS4861R05	
AN912-5S	.500	AS4861R05	AN912-5R
AN912-5T	.500	None	
AN912-5W	.500	AS4861W05	

AN912 Rev 10

TABLE II. Cross-reference data - Continued.

AN PIN (inactive)	Pipe size	Replacement AS PIN (for new design)	Replacement AN PIN (inactive)
AN912-6	.500	AS4861-06	
AN912-6D	.500	AS4861W06	AN912-6W
AN912-6J	.500	AS4861J06	
AN912-6K	.500	AS4861K06	
AN912-6R	.500	AS4861R06	
AN912-6S	.500	AS4861R06	AN912-6R
AN912-6T	.500	None	
AN912-6W	.500	AS4861W06	
AN912-7	.750	AS4861-07	
AN912-7D	.750	AS4861W07	AN912-7W
AN912-7J	.750	AS4861J07	
AN912-7K	.750	AS4861K07	
AN912-7R	.750	AS4861R07	
AN912-7S	.750	AS4861R07	AN912-7R
AN912-7T	.750	None	
AN912-7W	.750	AS4861W07	
AN912-8	.750	AS4861-08	
AN912-8D	.750	AS4861W08	AN912-8W
AN912-8J	.750	AS4861J08	
AN912-8K	.750	AS4861K08	
AN912-8R	.750	AS4861R08	
AN912-8S	.750	AS4861R08	AN912-8R
AN912-8T	.750	None	
AN912-8W	.750	AS4861W08	
AN912-9	.750	AS4861-09	
AN912-9D	.750	AS4861W09	AN912-9W
AN912-9J	.750	AS4861J09	
AN912-9K	.750	AS4861K09	
AN912-9R	.750	AS4861R09	
AN912-9S	.750	AS4861R09	AN912-9R
AN912-9T	.750	None	
AN912-9W	.750	AS4861W09	
AN912-10	1.000	AS4861-10	
AN912-10D	1.000	AS4861W10	AN912-10W
AN912-10J	1.000	AS4861J10	
AN912-10K	1.000	AS4861K10	
AN912-10R	1.000	AS4861R10	
AN912-10S	1.000	AS4861R10	AN912-10R
AN912-10T	1.000	None	
AN912-10W	1.000	AS4861W10	

AN912 Rev 10

Changes from previous issues. Marginal notations are not used in this revision to identify changes with respect to the previous issue due to the extent of the changes.

Referenced documents. In addition to SAE-AS4842, this document references the following:

ASME B46.1
SAE-AS4861
SAE-AS5201
SAE-AS71051

CONCLUDING MATERIAL

Custodians:

Army - AV
Navy - AS
Air Force - 99
DLA - CC

Preparing activity:

DLA - CC

(Project 4730-2011-074)

Review activities:

Navy - MC, SH
Air Force - 71

NOTE: The activities listed above were interested in this document as of the date of this document. Since organizations and responsibilities can change, you should verify the currency of the information above using the ASSIST Online database at <https://assist.daps.dla.mil>.