

NATIONAL AERONAUTICAL ESTABLISHMENT
LIBRARY

R. & M. No. 2620
(10,812)

A.R.C. Technical Report
NATIONAL AERONAUTICAL
ESTABLISHMENT
27 OCT 1952
MR. CLAPHAM, BEES.

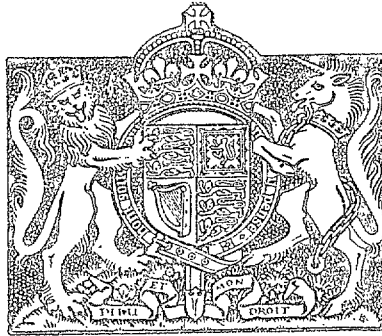

MINISTRY OF SUPPLY

AERONAUTICAL RESEARCH COUNCIL
REPORTS AND MEMORANDA

The Design and Installation of Small
Compressed Air Turbines for Testing
Powered Dynamic Models in the Royal
Aircraft Establishment Seaplane Tank

By

D. I. T. P. LLEWELYN-DAVIES, W. D. TYE and D. C. MACPHAIL

Crown Copyright Reserved

LONDON : HER MAJESTY'S STATIONERY OFFICE

1952

FIVE SHILLINGS NET

NATIONAL AERONAUTICAL ESTABLISHMENT
 LIBRARY

The Design and Installation of Small Compressed Air Turbines for Testing Powered Dynamic Models in the Royal Aircraft Establishment Seaplane Tank

By

D. I. T. P. LLEWELYN-DAVIES, W. D. TYE and D. C. MACPHAIL

COMMUNICATED BY THE PRINCIPAL DIRECTOR OF SCIENTIFIC RESEARCH (AIR), MINISTRY OF SUPPLY

*Reports and Memoranda No. 2620**
April, 1947.

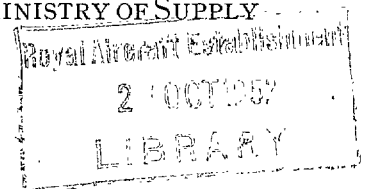

Summary.—This report describes the development of small lightweight air turbines for powering dynamic models in the R.A.E. Seaplane Tank. The units have proved to be rugged and reliable and power/weight ratios of 0.4 lb/b.h.p. have been achieved. The installation of the turbines in dynamic models and the provision of their air supply are also discussed.

1. *Introduction.*—For some time it has been desired to represent the effect of slip-stream on the water performance of dynamic models of seaplanes, but no really suitable source of power has been available. The requirements are:—

- (a) The power unit must be self-contained, or the supply leads must not affect the motion of the model under test.
- (b) Any external source of power must be carried on the tank carriage.
- (c) Dynamical similarity requires that the model weight should be proportional to the cube of the linear scale, the power to cube and a half power of the scale, and the propeller rotational speed to the inverse square root of the scale. The model centre of gravity must also be in the scale position. The table below sets out the weight and power requirements of a number of representative types of aircraft, the scales being chosen to suit a 9-ft wide tank with a carriage capable of 40 ft/sec.

Aircraft	Engines h.p.	Model scale	Scale h.p. per engine	Model Nacelle Diameter (in.)	Model Span (ft)	Model Weight (lb)
Auster	130	1/5	0.46	—	7.20	14.5
Sabre-engined Boat Fighter	2500	1/9	1.14	—	5.32	20.0
Lerwick	2 × 1350	1/12	0.225	5.0	6.75	16.2
Seaford	4 × 1700	1/16	0.10	3.75	7.80	17.1
Shetland	4 × 2500	1/19	0.08	3.2	7.90	17.5
Six-engined Civil Liner	6 × 5000	1/28	0.04	2.0	7.86	11.4

*R.A.E. Report Aero. 2192 received 25th August, 1947.

There seemed to be three practicable types of power unit: petrol engines, electric motors, and compressed air turbines. These types can be compared as follows:—

<i>Type</i>	<i>Advantages</i>	<i>Disadvantages</i>
Petrol engines	Easily available in the lower power ranges. Relatively light weight. Fuel self-contained. Small fuel consumption.	Uncertainty of operation. Lack of control. Fumes. Fire danger.
Electric motors	Small size if variable frequency a.c. is used. Convenience of power supply if d.c. is used.	Almost prohibitive weight. Risk of damage by wetting.
Air turbines	Simplicity, ruggedness, cheapness, light weight, no danger from wetting.	Problems of air supply without model constraint.

As it was considered that the problems of the air supply to the compressed air turbines could be overcome more easily than the disadvantages of the other engine types, and as the facilities for making them were available, it was decided to proceed with the development of the turbine power plants.

This report deals with the development of the compressed air turbines, their installation in the models, and means of supplying air to the model without affecting the freedom to heave and pitch.

The authors would like to acknowledge the help given to them by the staff of the Tool Room, R.A.E.

2. *Preliminary Development.*—In order to get a rough idea of the performance to be expected from a very small compressed air turbine, an air-driven gyro wheel of the helical flow type from a bank-and-turn indicator was brake-tested with the following results:—

Outside diameter	1.75 in.
r.p.m.	11,000
Air supply pressure (gauge)	20 lb/sq in.
Power	0.056 b.h.p.
Adiabatic efficiency	10 per cent

As it seemed probable that the efficiency could be improved appreciably whilst still keeping the design simple, an improved design, the Mk. 1 turbine, was made.

3. *Turbine, Mk. I.*—In order to attain a reasonable power with small diameter supply pipes, it was decided to use air pressures between 10 and 20 lb/sq in. gauge. In these circumstances the jet speed would approach 1000 ft/sec and, for maximum efficiency, the turbine bucket speed should be in excess of 400 ft/sec. To reach a bucket speed even comparable with this figure together with a propeller speed of about 4,000 r.p.m. and a diameter of 2.5 to 3 in., a turbine wheel diameter of 1.8 in. was chosen with a double reduction gear of 8.56 : 1 between the rotor and propeller shafts. At a propeller shaft speed of 4,250 r.p.m., this corresponds to a bucket speed of 280 ft/sec. The resulting loss in efficiency was accepted as it was not considered advisable to design for a higher rotational speed. The design, which was largely dictated by considerations of machining the nozzles and buckets, is illustrated in Figs. 1, 2. The air enters through a pipe shaped to the dimensions of the nozzle chest, is turned through 90 deg, and passes through the nozzles, which extend in an axial direction over part of the bucket width. Having passed through the buckets, the air is exhausted through the large gap adjacent to the nozzles. Partial admission was used with a total nozzle area of about 0.075 sq in. For ease of machining, the nozzles were made with a subsonic parallel-walled section, with faired inlets, and, in order to save weight, they were cut in a ring eccentric to the rotor shaft. In view of the high rotational speed, instrument type precision cup-and-cone ball bearings were used for the rotor and intermediate gear shafts; and the propeller shaft was carried on normal brass-caged angular-contact bearings.

As first tested, the turbine had nozzles 0.15 in. wide in the axial direction (half the bucket width), and a radial clearance between the wheel and casing of 0.040 in. At half design speed, the adiabatic efficiency including gearing was only 8 per cent. However, this efficiency was raised to 13 per cent by halving the axial width of the nozzles and reducing the turbine wheel radial clearance to 0.010 in.

The test results for this modified design are shown in Fig. 3: The maximum power recorded was 0.71 h.p., and a maximum adiabatic efficiency of about 20 per cent was obtained. This figure does not make any allowance for the gear losses and all efficiencies quoted are the overall efficiency, *i.e.*, b.h.p. at output shaft/energy due to adiabatic pressure drop through turbine (Appendix I). The turbine, which weighed 0.44 lb was made of Duralumin except for the shafts, bearings and gears, which were steel, so that the specific weight was 0.62 lb/h.p.

4. *Turbine, Mk. II.*—Although the turbine Mk. I operated satisfactorily, it became apparent that it suffered from the following limitations:—

- (a) The air pressure needed for obtaining high b.h.p.'s became excessive, especially when the pressure losses in the supply were taken into consideration.
- (b) The unit was too large to allow satisfactory exhaust arrangements to be made in the nacelles of small-scale models of large flying boats.
- (c) The efficiency was rather low.

It was decided to design a smaller unit using the same basic design as the Mk. I turbine, but to make the air inlet, nozzles, rotor shaft assembly and bearings a complete unit with provision for attaching suitable gear boxes to give the desired propeller shaft r.p.m. The main changes made were to use a full admission nozzle ring, reduce the rotor diameter to 1.5 in., and to use a more refined method of bearing adjustment. The turbine has been used in two main forms, a high-powered installation incorporating two turbines each driving one half of a contra-rotating propeller through a 10.15 : 1 single reduction gear, and a low-powered unit for powering multi-engined models. These two arrangements are shown in Figs. 4 and 5. In the case of the low-power unit, some of the nozzles were blocked in order to prevent the air consumption from becoming excessive, and the unit was run at half speed so as to make it possible to use a small ratio, single reduction gear box (5.25 : 1).

The turbine was tested over a wide range of speeds, air supply pressures and nozzle blockage coefficients, the results being shown in Figs. 6, 7. As can be seen from Fig. 6 the air consumption depends only on the supply pressure, while the power output varies considerably with speed, being a maximum at about 40,000 r.p.m. at which speed the turbine has a maximum efficiency of about 23 per cent. In view of the fact that the turbine was required to operate at about 20,000 r.p.m. under low-power conditions when installed in multi-engined models, the tests were extended (Fig. 7) to cover the effect of blocking some of the nozzles. This allowed the supply pressure to be raised whilst keeping a low air consumption, the higher supply pressure making control of the output more precise. In the unblocked state the turbine had 36 nozzles each 0.08 in. high and 0.05 in. wide and any of these nozzles could be blocked as required. Preliminary tests at 50 per cent blockage showed that at low speeds (15,000 r.p.m.) it was more efficient to block the nozzle in one continuous group, rather than to distribute the blockage around the jet ring, but at higher speeds (25,000 r.p.m.), there was very little difference in efficiency whatever form the blockage took. Thus in the tests that followed, the required blockage was obtained by blocking consecutive nozzles. Decreasing the nozzle area was very effective in reducing the air consumption and power of the turbines, the reduction in both being nearly proportional to the percentage blockage, but with a slightly greater reduction in power than in air consumption, with the result that the turbine efficiency at all speeds decreased with decrease in nozzle area.

The dual rotation unit weighed 0.91 lb complete and could give a maximum output of 1.16 h.p., giving a specific weight of 0.785 lb/h.p. The specific weight of the single rotation unit is very difficult to define, but if the power is assumed to be that at 25,000 r.p.m. with no nozzles blocked, a specific weight of 0.89 lb/h.p. is achieved, as the unit weighs 0.33 lb.

5. *Turbine, Mk. IIIa.*—With the introduction of jet propulsion and propeller-turbine engines, the existing model turbines could not supply the power required for the propeller turbine units on single-engined models and also were too large to drive a fan inside a nacelle so as to represent jet effects. Owing to the limitation of air supply, the only way of obtaining more power was to increase the turbine efficiency. As it was considered difficult to increase appreciably the efficiency of the helical flow turbine, it was decided to design a multi-stage axial flow impulse turbine to use about 80 cu ft of free air per minute at a gauge pressure of 20 lb/sq in., the diameter being kept as small as possible.

Accordingly a four-stage turbine was designed having a rotor diameter of 1.5 in., a blade height of 0.2 in. and a nozzle angle of 25 deg. The jet speed obtained under these conditions was 650 ft/sec and with a design rotational speed of 45,000 r.p.m., this gives a value of 0.39 to the ratio bucket speed/jet speed. This is rather below the optimum value, but it was not considered advisable to increase the rotational speed further. Figs. 8, 9 show the general features of the turbine and the following points should be noted:—

- (a) For manufacturing reasons partial admission is used, except in the last stage, to allow for the expansion of air through the turbine.
- (b) The small clearance (0.01 in.) between the nozzle and rotor rings to prevent air from bye-passing the nozzles.
- (c) The large clearance (0.15 in.) between the rotor blades and the nozzle entry, to minimise the losses due to the exit air from one stage hitting against the blank parts of the nozzle plate of the next stage.
- (d) Rotor blades and nozzles end-milled out of the solid rims of their respective discs.
- (e) The outside shell made in cylindrical sections which locate the nozzle rings.
- (f) Rotors splined to the rotor shaft for ease of assembly and adjustment.
- (h) As in the case of the Mk. II turbine the unit is a complete assembly up to the rotor shaft pinion, and provision is made for the attachment of gear boxes of various ratios.

The results of the brake tests made on this turbine are shown in Fig. 10. The maximum efficiency (including gear losses) was about 37 per cent and by variation of the rotational speed, an efficiency of greater than 33 per cent can be maintained over a wide range of powers. As shown in the table below, the rotational losses increase appreciably with speed, especially above 50,000 r.p.m.

Rotor speed (r.p.m.)	19,300	38,500	51,300	64,200
Adiabatic h.p. to turn turbine	0.25	0.51	0.58	1.30

The maximum power recorded was 1.79 h.p. and thus, for a turbine weight of 0.72 lb, a specific weight of 0.40 lb/h.p. was achieved.

6. *Turbine, Mk. IIIb.*—A requirement arose to reproduce the effects of slipstream on a model of a very large six-engined flying boat. Owing to limitations of tank size, the model had to have a total weight of about 11 lb, and although each engine unit only had to develop 0.04 h.p., the nacelle diameter had to be about 2 in. It was not considered practicable to drive the propellers, by means of shafting, from a central turbine and the Mk. II unit was too large to fit into the nacelle unless a double reduction gear was used with the corresponding weight penalty. It was not possible to use the Mk. II turbine as a direct drive unit as the efficiency at the speeds required (6,000 r.p.m.) was too low and the Mk. III unit, although of the right diameter, was too long and too heavy. It was eventually decided to use the first three stages of the Mk. IIIa turbine as a direct drive unit.

The turbine was tested with the results shown in Fig. 11. As was to be expected the efficiency rose considerably with increase of speed, but even at the lowest speed tested it was greater than 10 per cent. The maximum power recorded was 0.40 h.p. and thus, as the turbine weighed 0.31 lb, the specific weight of the unit is 0.775 lb/h.p.

7. *Installation of the Turbines in Models.*—In the past, tank models had been propelled by means of a fitting attached to the hull at the scale position of the centre of gravity; this method was not entirely satisfactory because:

- (a) the vertical movement of the model was restricted to prevent damaging the model on the suspension;
- (b) the presence of a large bluff body and a hole in the centre of the wing caused considerable deterioration in the stalling characteristics of the wing, already bad because of the low Reynolds number, and also affected the airflow round the after-body which can make large differences to the porpoising stability of flying boats;
- (c) the weight of the moving part of the fitting (2 lb) had to be included as part of the model weight.

It was decided to lead the turbine air supply in through the wing tips of the model. The point of attachment to the model had to be in line with the model centre of gravity which is generally below the wing tip and, as shown in Fig. 12, two main types of wing tip fixing have been used, a semi- or fully-cantilevered aluminium tube or a wooden box fitting. The tubular fixing is used when large powers are required as it has a small pressure loss, while the box type is used on most routine work on large models as it enables rapid adjustment of the model centre of gravity position. The alteration to the wing tips slightly affects the stalling characteristics of the wing, but the effect is small compared to the effects of slipstream and Reynolds number.

The air is led from the wing tips to the turbines by means of aluminium or rubberised fabric tubing (Fig. 12) and the exhaust air escapes to the atmosphere through the rear of the nacelles, under the wing, or through the bottom of the fuselage in the case of a single-engined model. Fig. 12 also shows the attachment of the turbines to the model.

The compressed air is supplied from a Roots blower mounted on the tank carriage and a maximum supply of about 90 cu ft of free air per minute at a gauge pressure of 20 lb/sq in. is available. A filter is fitted to the blower intake so as to prevent dust, etc., from the carriage floor entering the system. The delivery pipe has a blow-off valve in it for control of the supply pressure and divides to deliver the air to a point in line with the two tubular arms which convey the air to the model wing tip fixings. In order to avoid constraining the model, a length of specially flexible wire-reinforced rubber tubing was used to connect the delivery pipes and the tubular arms. The lift and drag interferences due to the straightening of the rubber tube under pressure have been measured and found to be less than 0.1 lb. The arms were originally made of 1 in. outside diameter, 17 gauge Duralumin tubing; these arms deflected about 1 in. for every pound applied at the model suspension point and the pressure drop when passing 40 cu ft of free air per minute through each arm at a gauge pressure of 15 lb/sq in. was about 0.9 lb/sq in. These arms were replaced by $1\frac{1}{4}$ in. outside diameter Duralumin tubing of similar thickness which had a smaller pressure drop and also greater stiffness (0.3 lb/sq in. pressure drop and 0.5 in. deflection per lb applied load).

In order to separate horizontal and vertical motions and forces on the model during porpoising, it was necessary that the suspension point should move in a straight vertical line when the model heaved; this was achieved by making the supply arms part of a modified Watts linkage as shown in Fig. 13. In practice the arm OQ was omitted and the point O was guided by a roller on a track. The length of the arms was determined by the requirement that the model should run in the undisturbed air in front of the carriage and the linkage was designed to give the suspension point a vertical motion of 2 ft from the normal water level of the tank. The maximum deviation from the vertical in this range was $\frac{1}{8}$ in. As once the designed travel was exceeded the motion departed rapidly from a straight line, rubber pads were fitted to prevent the arms from exceeding the designed travel. If it is assumed that the arms are balanced about O, there will be an out-of-balance force on the model when at the extreme travel due to the system not being balanced about Q; this out-of-balance force was approximately 0.15 lb in the extreme positions and as this only amounted to about 1 per cent of the weight of a normal model, it has been neglected.

In order to get the air from the arms to the model it was necessary to turn it through 90 deg, and at the same time to allow the model to pitch freely about the suspension point, and a labyrinth-packed hollow trunnion was developed to meet this requirement (Fig. 14a). The inner rotating labyrinth sleeve was located in its housing by a spindle and ball bearing at its outer end and by means of three ball-races which roll on the machined surface of the housing at the inner (model) end. The radial clearance between the labyrinth sleeve and housing was 0.0025 in. Large holes are cut in the labyrinth sleeve where it crosses the main supply pipe in order to allow unobstructed flow of air to the model. As can be seen from Fig 14a the holes are not symmetrically placed and thus there is only a small angular range in which there is unobstructed flow; in order to ensure that the sleeve is in the correct position, a flat was made on each pulley carrying the external bearings and when this was facing forwards, the angular range available before impeding the air supply was sufficient to cover all model oscillations occurring in normal tests. In the case of the box-type wing-tip fitting, the model is attached to the labyrinth by means of a long bolt which passes through the labyrinth to screw into a fitting on the far side of the box and thus mate the labyrinth against a flanged fitting on the model to provide an air-tight joint. When it is desired to fit a model with the cantilevered-type fitting, a screwed adaptor is bolted to the labyrinth and screws into a nut attached to fixing (Fig. 12). In both types of fitting the securing bolts are made weak deliberately so as to minimise the damage in the event of a crash, by allowing the model to break away from the supporting arms.

When the diameter of the tubular supporting arms was increased the design of the labyrinths was altered. In order to decrease the pressure drop it was decided to replace the sharp bend by a radiused one, cast in magnesium, and this resulted in a change of the basic design as shown in Fig. 14b. It had been found that constant maintenance was necessary to prevent the external bearings on the first design from freezing up owing to having to operate in spray, and so all the bearings in the new design are internal and protected from water. Attachment to the model is by means of a flanged plate and large diameter nut attached to the model, the nut screwing on to the outer casing of the labyrinth and drawing the plate against the labyrinth to make an air-tight joint.

Tests were made to determine the leakage and it was found that at a gauge pressure of 10 lb/sq in. it was less than 1 cu ft/min.

The effective vertical inertia of the swinging arms and labyrinths was calculated to be equivalent to an additional weight of 1.2 lb at the model centre of gravity. This value varies with the position of the swinging arms, increasing very rapidly towards the end of the design travel, the figure quoted being for the mean position. If so desired this value can be halved by considering the labyrinths as part of the model weight.

A general view of a powered model, rigged on the Seaplane Tank carriage is shown in Fig. 15.

8. *Discussion.*—When the Mk. I and II turbines were designed, it was decided to use a helical flow design in order to avoid close limits and thus make the manufacture simple. When it became necessary to use axial-flow turbines in order to increase the efficiency, close limits (± 0.001 in.) were required on the axial dimensions if the bye-pass leakage past the nozzles was to be kept small. In addition, the radial clearance between the rotors and the casing was very small (0.0025 in.) and so close limits were also necessary on the diameters of the rotors and casing. For simplicity in manufacture there was no twist in either the nozzles or rotor blades, which were end-milled on an engraving machine out of the rims of their respective discs. Owing to standardisation in design, there are relatively few different parts in the Mk. III turbines and once jigs have been made for certain of the parts, the manufacture became comparatively straightforward, although the life of the end-mills used for profiling the nozzles and rotor blades was short owing to the small size of the cutter.

As already mentioned, the Mk. I and II turbines used instrument-type precision cup-and-cone ball bearings for the rotor shaft; these were designed for high rotational speeds (100,000 r.p.m.) under very small loads, and were used in preference to the normal brass-caged angular-contact bearings, designed for low speeds (5,000 r.p.m.) which were used on the other shafts. Prolonged

running of the former bearings showed that there was a tendency for the rather weak cages to break and also for undue wear to occur on the cones which may have been a contributory cause to the failure of the cages. As a result of this experience, it was decided to use only brass-caged angular-contact bearings in the Mk. III turbines, and these have been satisfactory except for one cage failure. Owing to the high rotational speeds it was not found possible to oil the bearings or gearwheels as the oil was thrown off immediately and it was found that the most satisfactory method of lubrication was to pack the bearings with heavy grease and to apply a thin film of grease to the gearwheels.

At the time of writing this report the Mk. I and II turbines have been operated for routine tests in the Seaplane Tank for about five years and except for the bearing troubles mentioned above, the only failures that have occurred have been due to the rotor becoming loose on its shaft and creeping enough to cause rubbing, but even this did not cause a complete failure of the unit. The actual running time is relatively small as, in general, the turbines are used in short bursts of 1 to 2 min in every 10 min. When actually running, however, the turbines are liable to sudden variations in speed owing to spray passing through the propellers. During this period of operation, accidents have occurred involving the Mk. I units, one of which has been in three crashes, but no damage has been done to the turbines. Owing to the relatively large clearances on the Mk. I and II units it was not necessary to use a high-grade air-filter on the blower intake but one was necessary when the Mk. III unit was used owing to the small clearances between the rotors and casing. The Mk. III turbines have been operated for about nine months without any trouble except for a bearing failure and slight rubbing of the rotor blades against the casing in the four-stage unit. In all cases the only maintenance needed is an occasional regreasing.

The performance data of the turbines is summarised in Table 1. Control during operation is by varying the supply pressure and, provided the load is not altered, the repeatability of operation depends solely on the accuracy with which the supply pressure can be reset.

APPENDIX I

Methods used in Determining Turbine Performance

1. *Determination of Brake Horse Power.*—A normal friction dynamometer was used for testing the Mk. I and IIa turbines, but the system was modified as shown in Fig. 16 for testing the other units. The reason for the change was that application of the brake load to the drum in the original method meant applying an appreciable bending moment to the shaft, which, in the case of the Mk. IIb and IIIb units, was made of Duralumin; the revised method allows the brake torque to be taken almost solely as torsion load and thus enables high powers to be developed without risk of whirling.

In the first tests the rotational speed was measured by means of a normal tachometer, but when the brake testing rig was changed it was decided to use a 'halved' black and white disc and a stroboscope to measure the speed as a wider range of r.p.m. could be covered and no power was absorbed.

Thus from a knowledge of the brake torque and rotational speed the output b.h.p. could be calculated.

2. *Determination of the Adiabatic Horse Power.*—In order to determine the adiabatic h.p. it was necessary to know the volume and pressure of the air supplied to the turbine.

The air was supplied to the turbine intake through a length of straight, constant-diameter tubing containing a pitot tube and static hole. The air-supply pressure was measured on a

normal dial-type pressure gauge and the difference between the dynamic and static pressures on a vertical water manometer. The theoretical volume of free air (V cu ft/min) supplied is given by:

$$V = AU \rho / \rho_0$$

where A cross-sectional area of pipe (sq ft),
 U velocity of air through pipe (ft/min),
 ρ air density in pipe,
 ρ_0 air density under atmospheric conditions.

The velocity was measured at the centre of the tube, and in order to allow for boundary-layer effects a correction factor of 0.8 was applied, thus

$$V = 0.8 AU \rho / \rho_0.$$

The adiabatic horsepower is given by:

$$\frac{\gamma}{\gamma-1} P V \left[\left(\frac{P_2}{P} \right)^{\gamma-1/\gamma} - 1 \right] / 33000$$

where γ ratio of the specific heats of air (1.40),
 P exhaust pressure (lb/sq ft),
 P_2 supply pressure (lb/sq ft).

Hence, when exhausting to atmosphere, the adiabatic horsepower is given by

$$0.0156 V \left[\left(\frac{P_2}{P} \right)^{0.286} - 1 \right].$$

3. *Turbine Efficiency.*—The efficiencies given in the performance charts are the overall efficiencies including gear losses, as it was not found possible to separate these from the other losses.

4. *Power/Weight Ratio.*—The power/weight ratios quoted are not the maximum obtainable, but are based on the maximum recorded power. This power was decided quite arbitrarily by testing either to a given supply pressure or air consumption, and was in no case limited by mechanical considerations.

TABLE I

Turbine Characteristics

Turbine	Mk. I	Mk. IIa	Mk. IIb	Mk. IIIa	Mk. IIIb
Height (in.)	2.74	4.58	2.48	2.53	2.16
Breadth (in.)	2.22	2.76	2.22	2.16	2.16
Overall length (in.)	5.0	6.50	4.80	7.70	4.85
Weight (lb)	0.44	0.91	0.33	0.72	0.31
Overall maximum adiabatic efficiency (per cent)	20	22	16	37	17.5
Design r.p.m.	40,000	43,000	25,000	40,000	8,000
Reduction ratio	8.56 : 1	10.15 : 1	5.25 : 1	25.6 : 1	nil
Maximum power (h.p.)	0.71	1.16	0.37	1.79	0.40
Weight/power ratio (lb/h.p.)	0.620	0.785	0.89	0.402	0.775

6

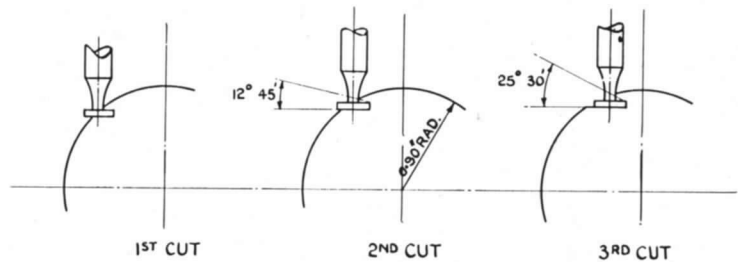
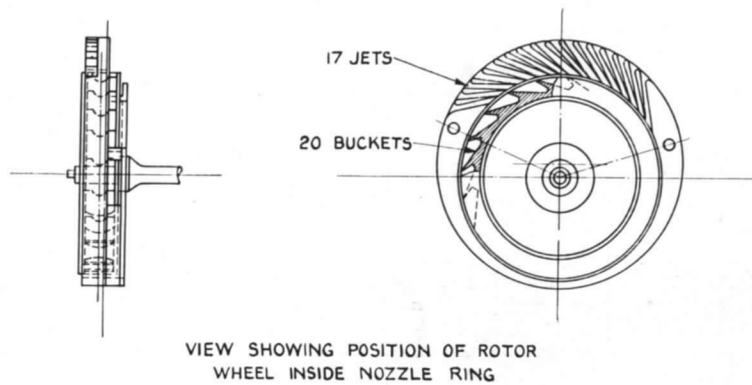

SKETCH SHOWING METHOD OF MACHINING
BUCKETS IN ROTOR WHEEL

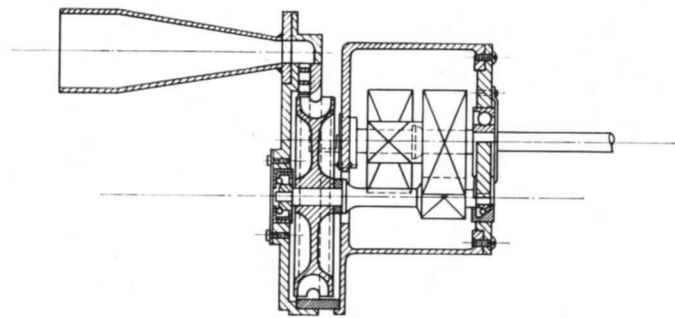

FIG. 1. Mk. I compressed-air turbine,

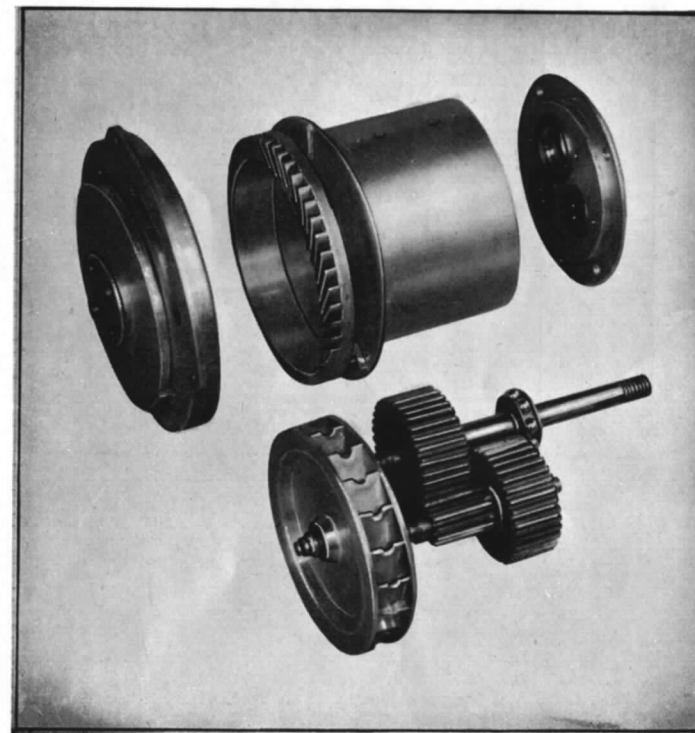
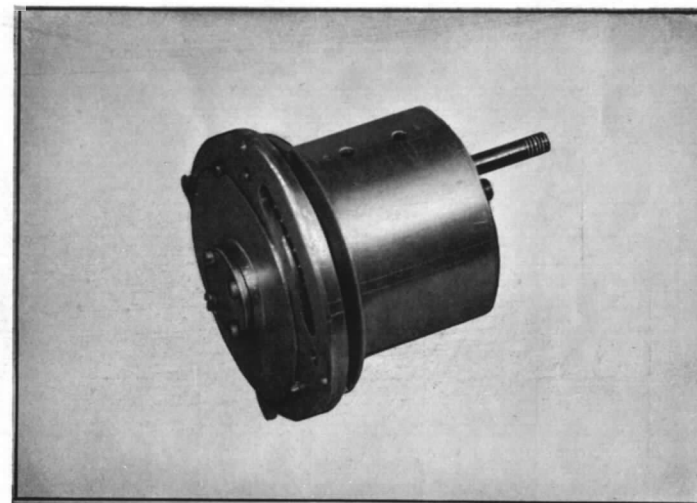

FIG. 2. Mk. I compressed-air turbine,

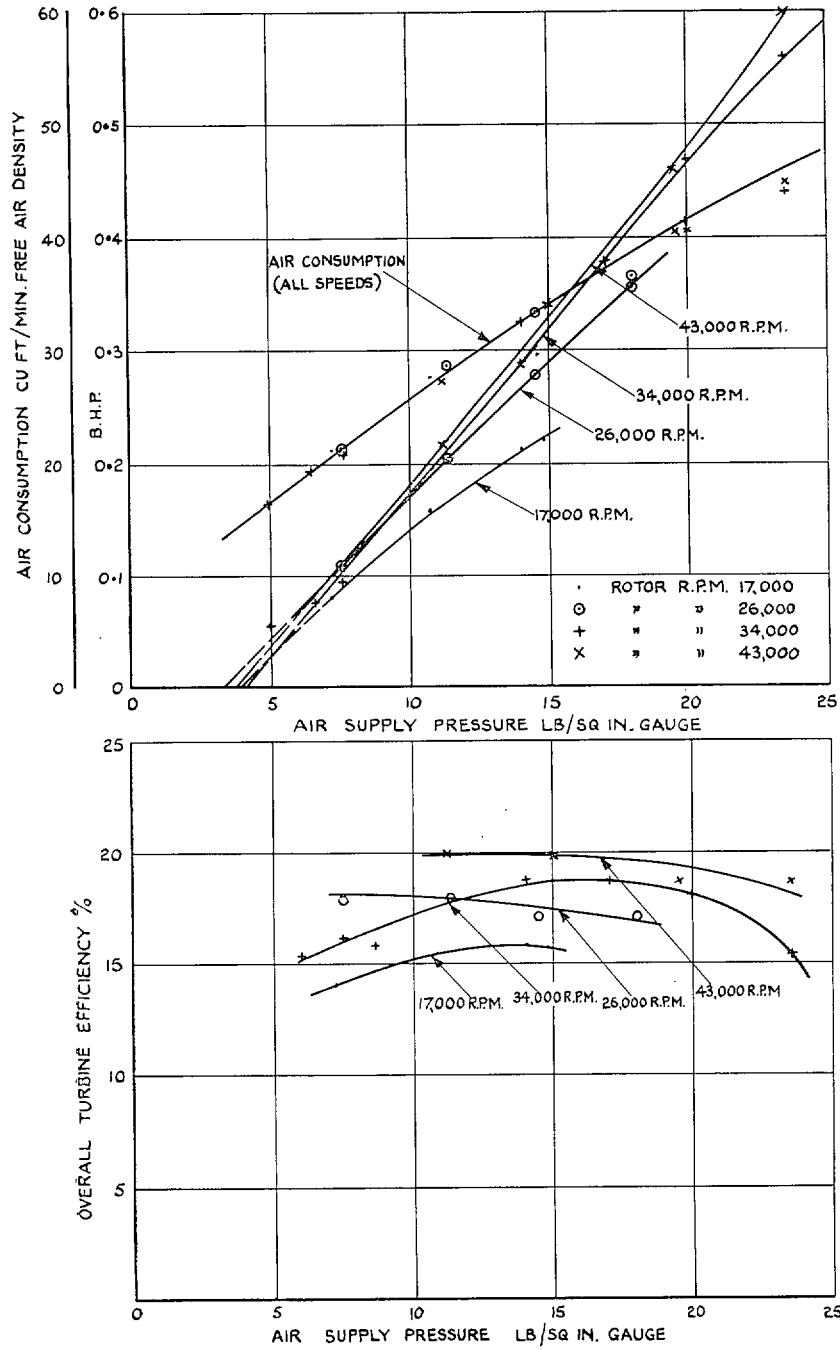

FIG. 3. Performance data, Mk. I compressed-air turbine

11

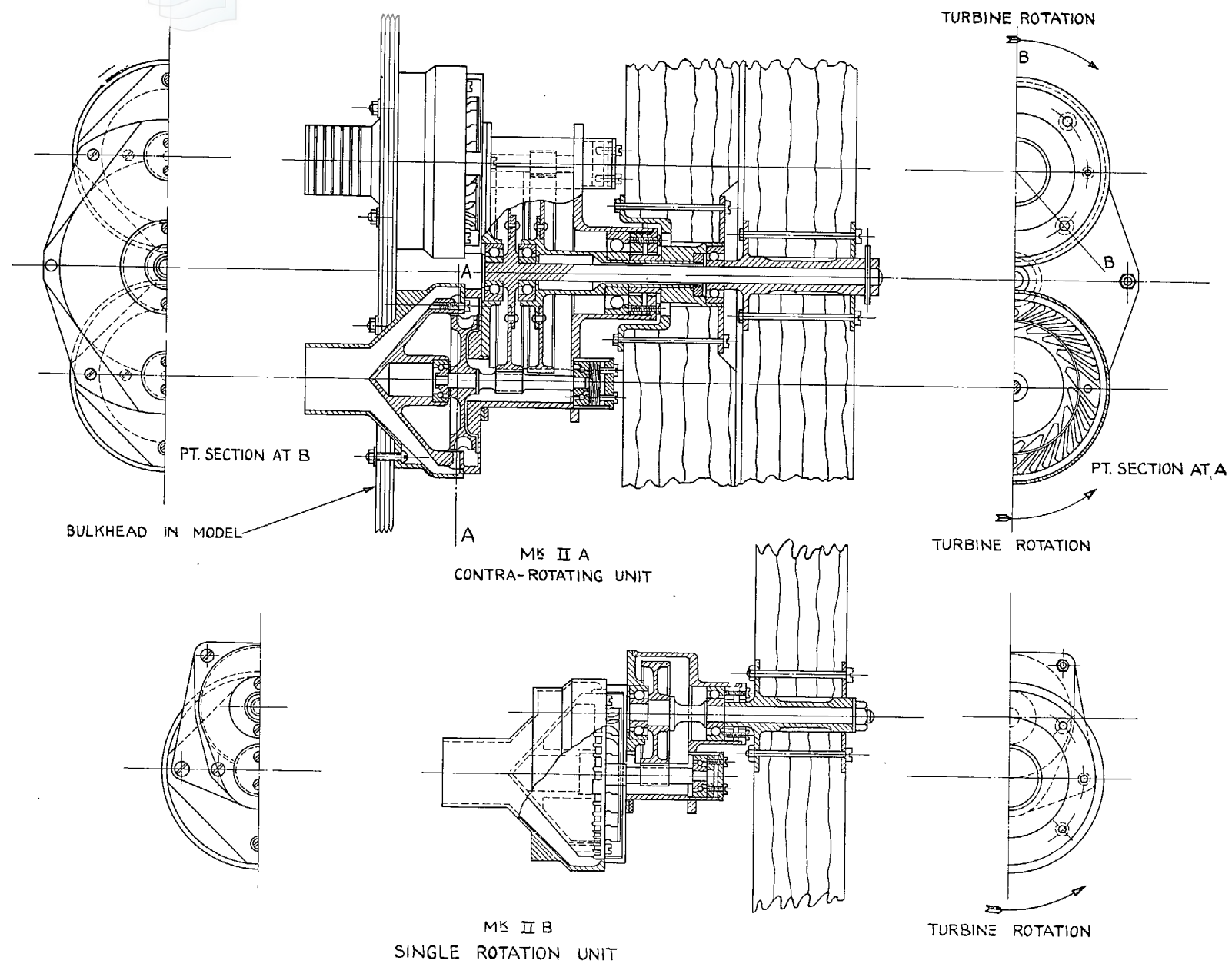

FIG. 4. Mk. II compressed-air turbine.

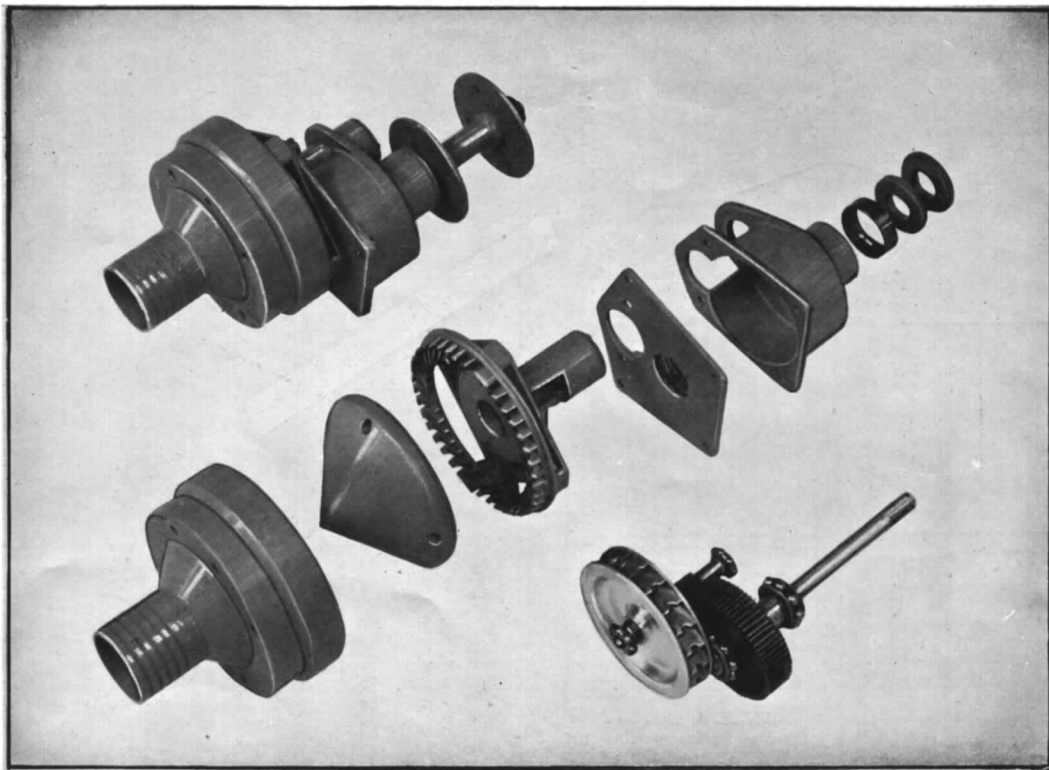

FIG. 5. Mk. IIb compressed-air turbine.

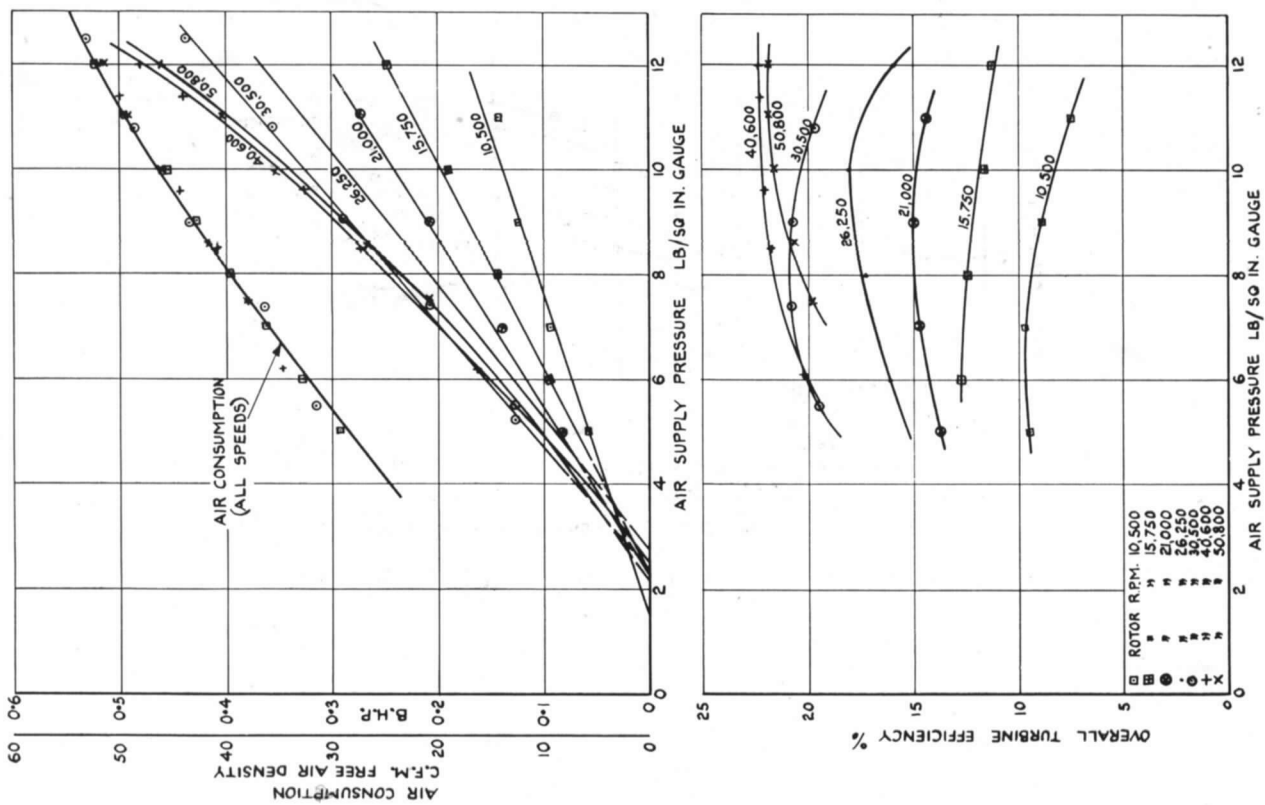

FIG. 6. Performance data, Mk. II compressed-air turbine.

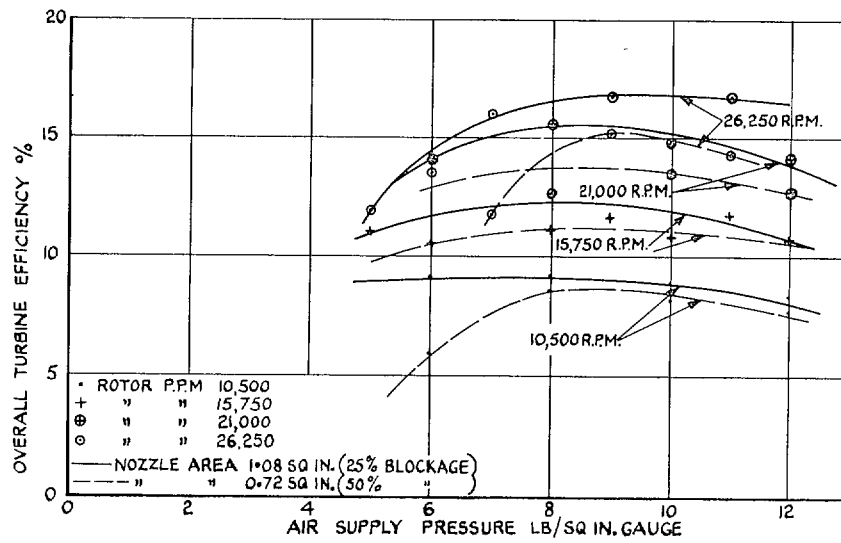
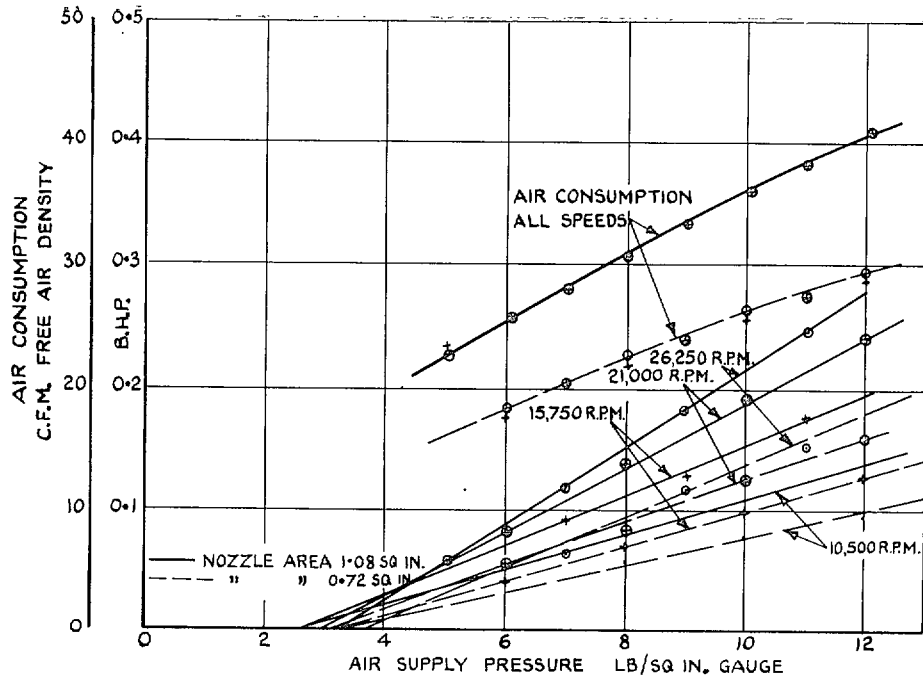
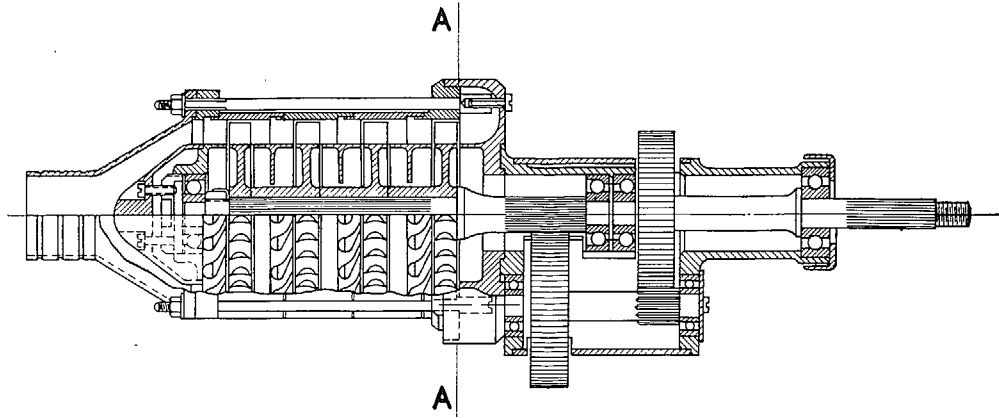
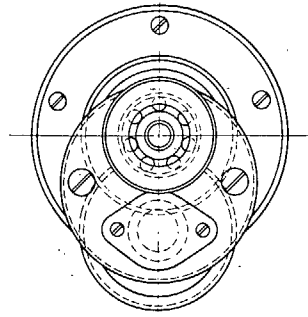
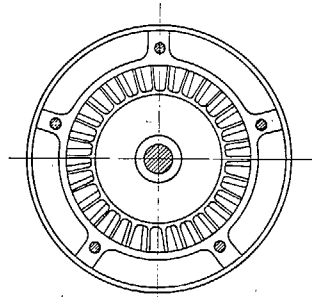

FIG. 7. Effect of variation of nozzle area on performance. Mk. II compressed-air turbine.



MK. III A
FOUR STAGE GEARED

14



VIEW OF EXHAUST STAGE
THROUGH SECTION A-A

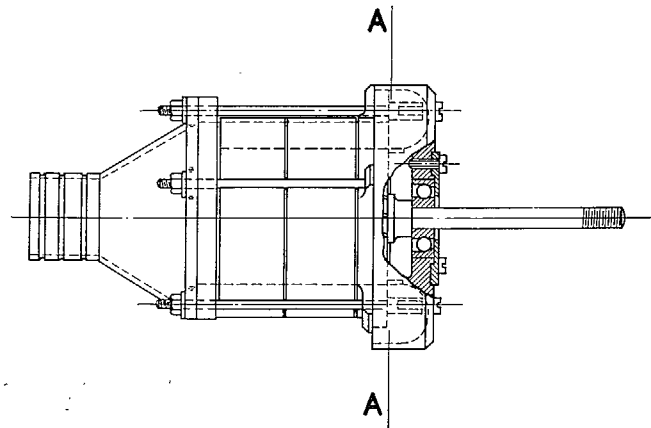

MK. III B
THREE STAGE DIRECT DRIVE

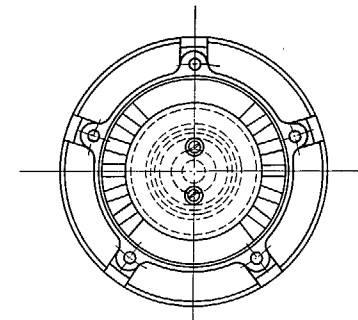

VIEW WITH INTAKE REMOVED
SHOWING RESTRICTED NUMBER
OF JETS AT FIRST STAGE

NOTE:- THESE TWO VIEWS ARE
IDENTICAL IN BOTH UNITS

FIG. 8. Mk. III multi-stage axial-flow turbine.

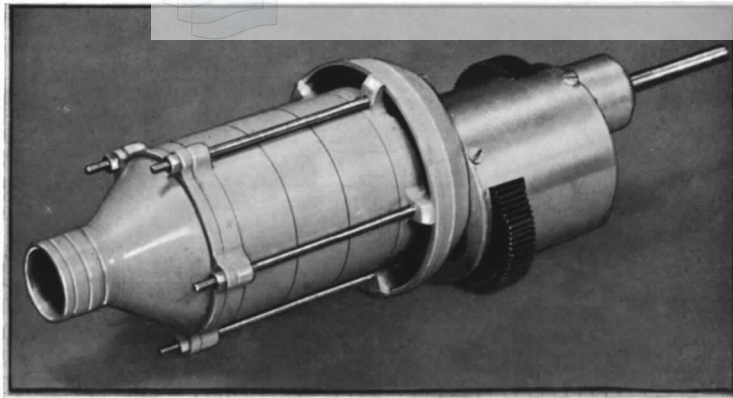

Mk. IIIa four-stage turbine

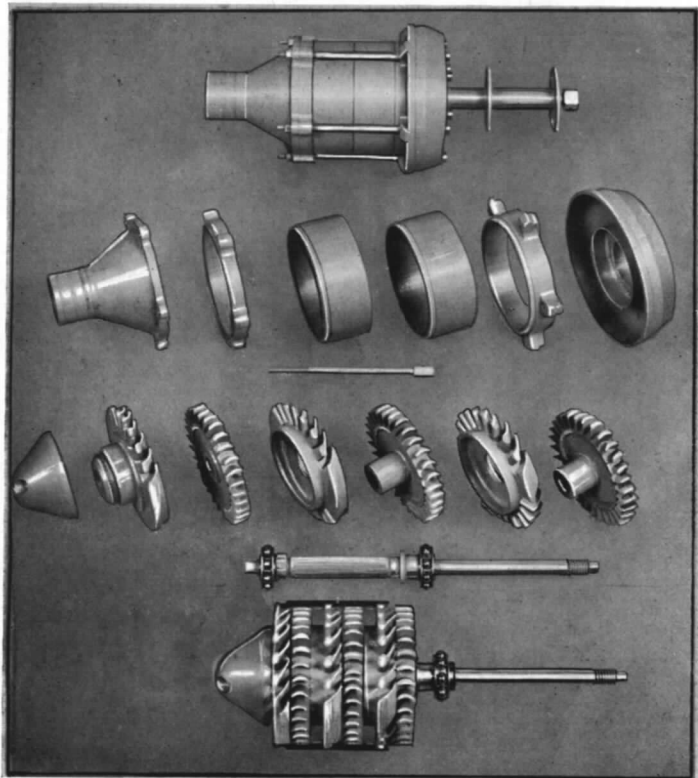

Mk. IIIb three-stage direct-drive turbine
 FIG. 9. Mk. III compressed-air turbines.

15

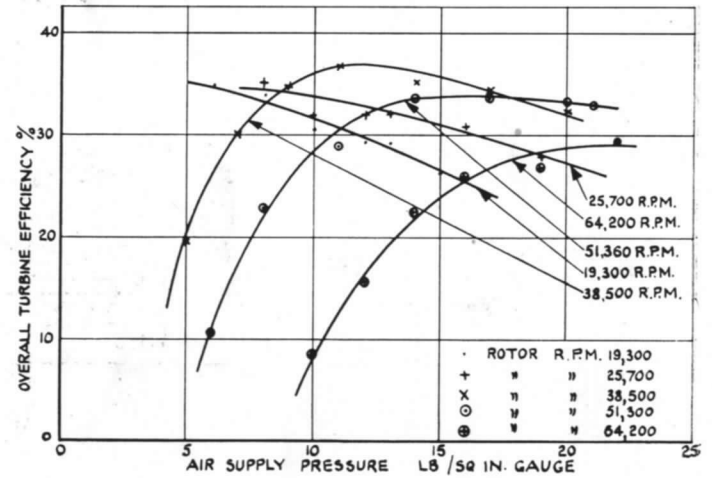
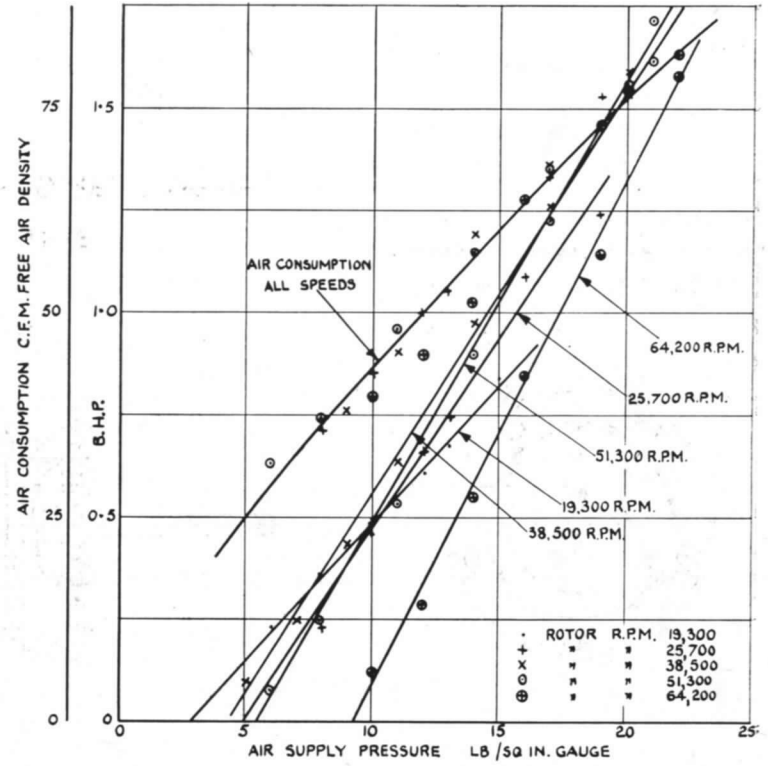

FIG. 10. Performance data,
 Mk. IIIa four-stage axial-flow geared turbine.

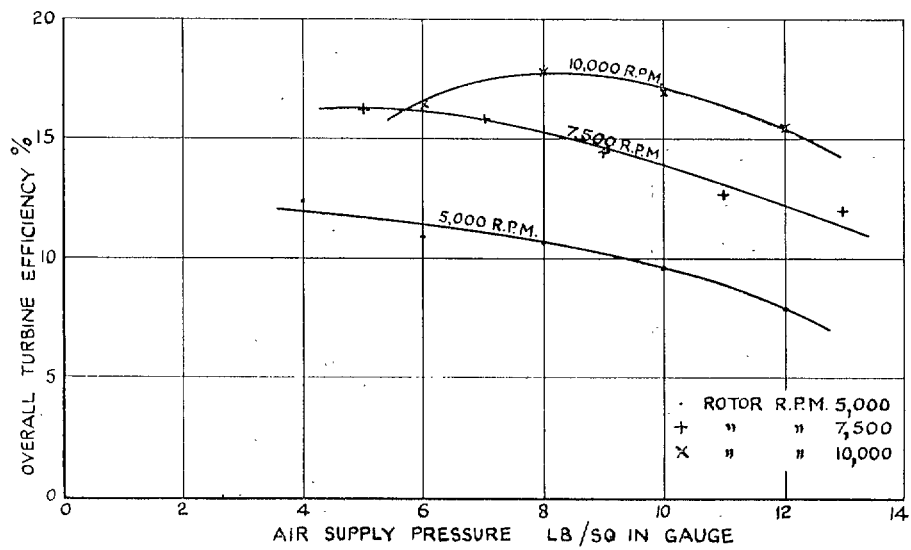
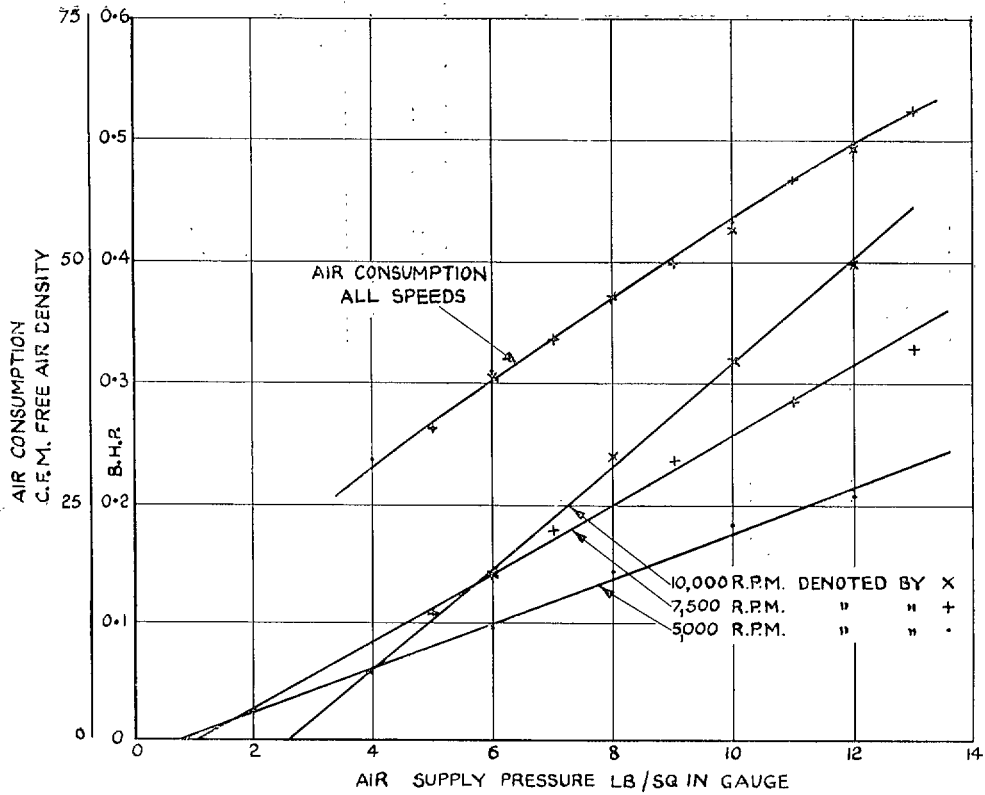
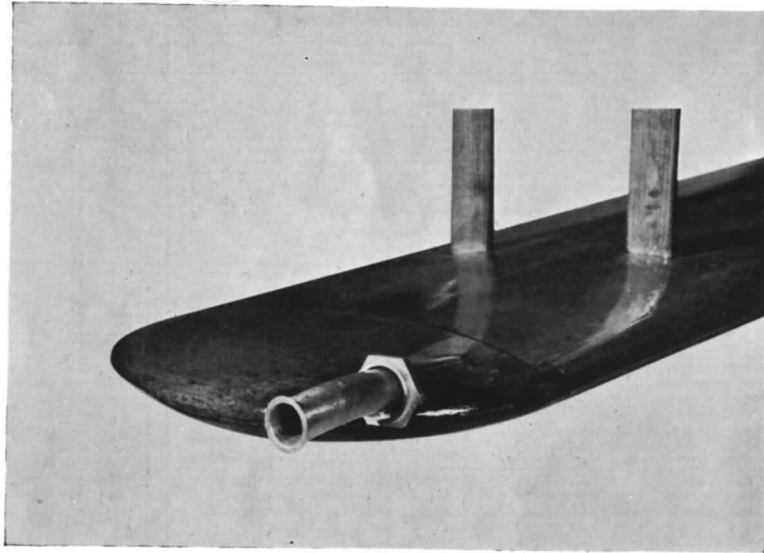
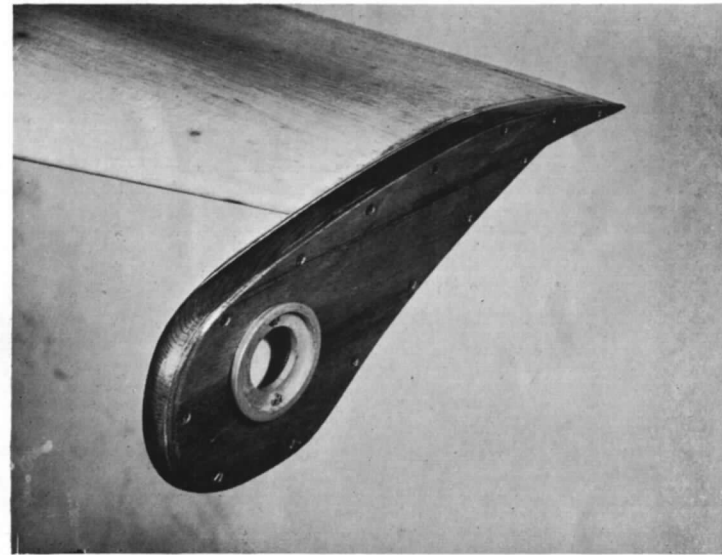

FIG. 11. Performance data, Mk. IIIb three-stage axial-flow direct-drive turbine.



Cantilever



Wing-tip connections

Box

17

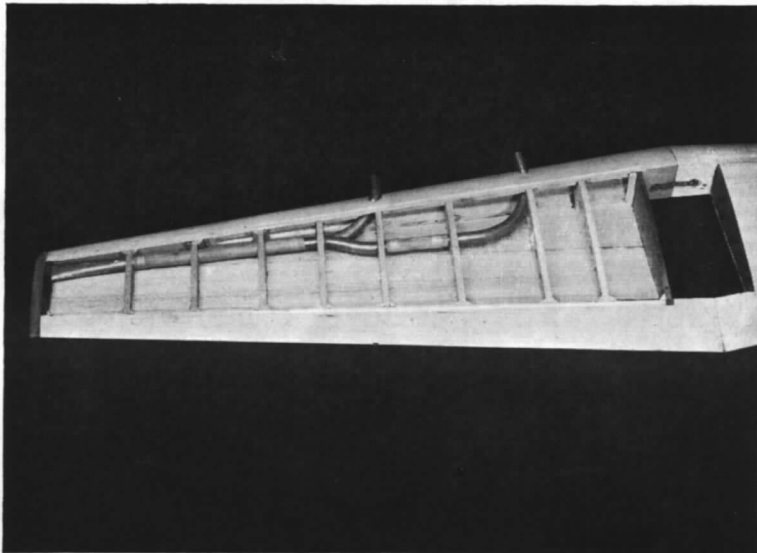

Air-supply piping in wing

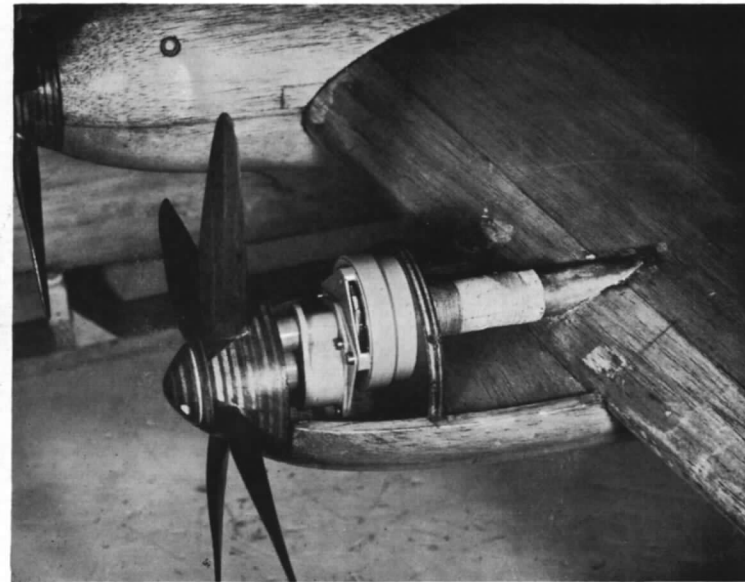

Mk. IIb turbine installed in nacelle

FIG. 12. Installation of turbines.

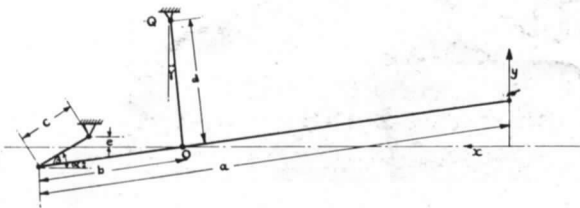

LET $x = y = 0$ AND $\gamma = 0$ WHEN $\alpha = 0$
 IN GENERAL

$$y = a \sin \alpha - c (\sin \beta - \sin \beta_0)$$

$$x = a (1 - \cos \alpha) - c (\cos \beta_0 - \cos \beta)$$

AND

$$\sin \beta = \frac{c + b \sin \alpha - d (1 - \cos \gamma)}{c}$$

$$\sin \beta_0 = \frac{c}{b}$$

FOR REASONS DICTATED BY OPERATING CONDITIONS

$$a = 107", \quad b = 23", \quad d = 15"$$

SO IN ORDER THAT $x = 0$ WHEN $y = \pm 12"$

$$c = 5.50" \quad e = 0.025"$$

FIG. 13. Geometry of straight line linkage.

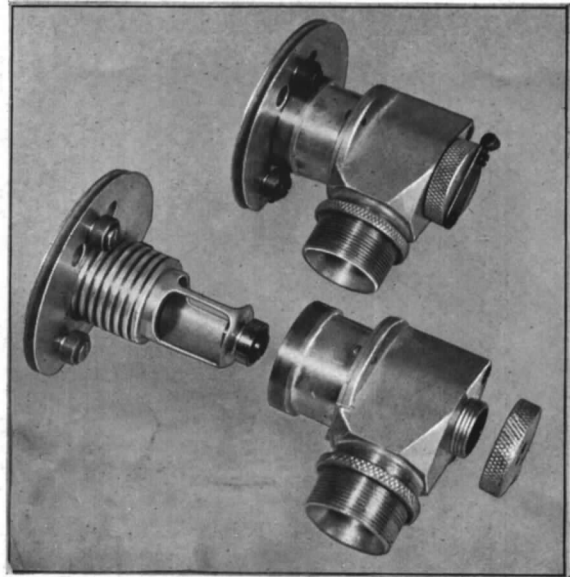

(a) Mk. I

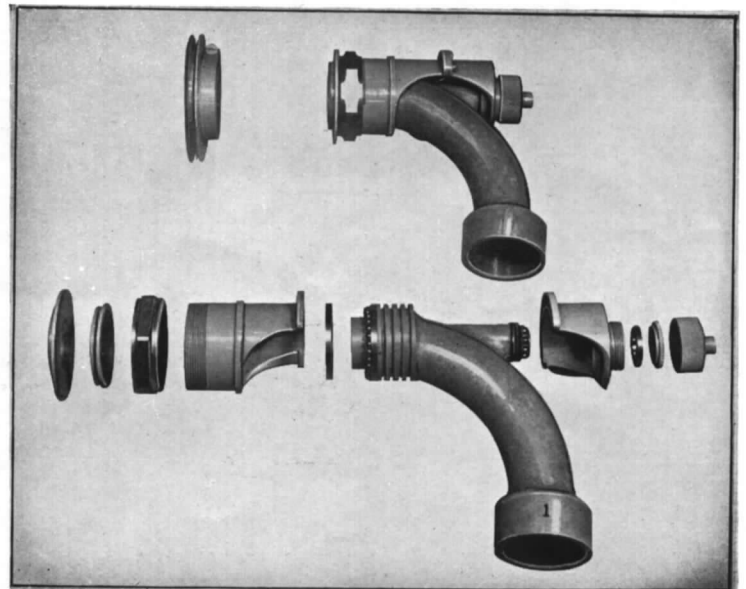

(b) Mk. II

FIG. 14. Labyrinth connections.

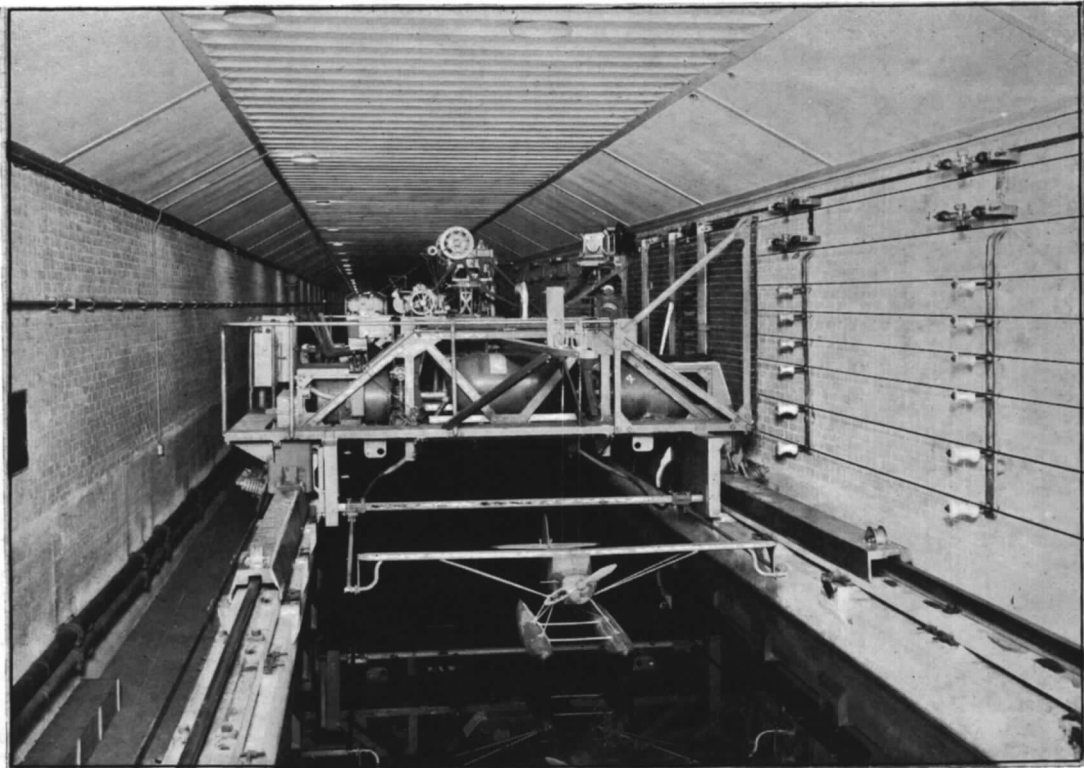

FIG. 15. General view of rig.

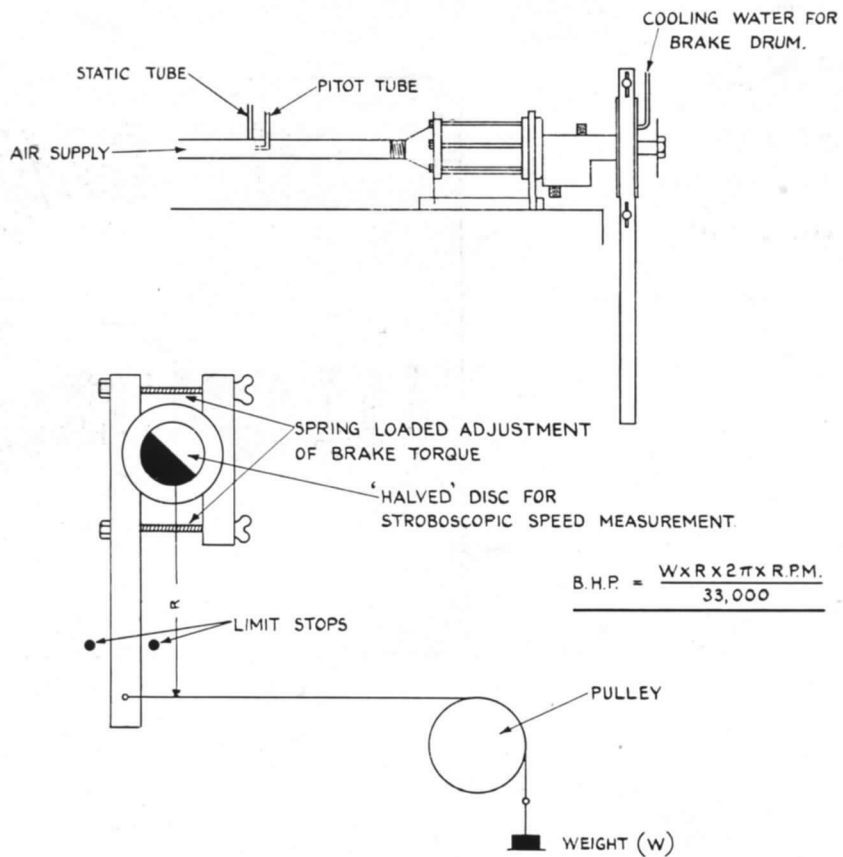

FIG. 16. Diagrammatic sketch of brake-testing apparatus.

Publications of the Aeronautical Research Council

ANNUAL TECHNICAL REPORTS OF THE AERONAUTICAL RESEARCH COUNCIL (BOUND VOLUMES)—

- 1934-35 Vol. I. Aerodynamics. *Out of print.*
 Vol. II. Seaplanes, Structures, Engines, Materials, etc. 40s. (40s. 8d.)
- 1935-36 Vol. I. Aerodynamics. 30s. (30s. 7d.)
 Vol. II. Structures, Flutter, Engines, Seaplanes, etc. 30s. (30s. 7d.)
- 1936 Vol. I. Aerodynamics General, Performance, Airscrews, Flutter and Spinning. 40s. (40s. 9d.)
 Vol. II. Stability and Control, Structures, Seaplanes, Engines, etc. 50s. (50s. 10d.)
- 1937 Vol. I. Aerodynamics General, Performance, Airscrews, Flutter and Spinning. 40s. (40s. 10d.)
 Vol. II. Stability and Control, Structures, Seaplanes, Engines, etc. 60s. (61s.)
- 1938 Vol. I. Aerodynamics General, Performance, Airscrews. 50s. (51s.)
 Vol. II. Stability and Control, Flutter, Structures, Seaplanes, Wind Tunnels, Materials. 30s. (30s. 9d.)
- 1939 Vol. I. Aerodynamics General, Performance, Airscrews, Engines. 50s. (50s. 11d.)
 Vol. II. Stability and Control, Flutter and Vibration, Instruments, Structures, Seaplanes, etc. 63s. (64s. 2d.)
- 1940 Aero and Hydrodynamics, Aerofoils, Airscrews, Engines, Flutter, Icing, Stability and Control, Structures, and a miscellaneous section. 50s. (51s.)

Certain other reports proper to the 1940 volume will subsequently be included in a separate volume.

ANNUAL REPORTS OF THE AERONAUTICAL RESEARCH COUNCIL—

1933-34	1s. 6d. (1s. 8d.)
1934-35	1s. 6d. (1s. 8d.)
April 1, 1935 to December 31, 1936	4s. (4s. 4d.)
1937	2s. (2s. 2d.)
1938	1s. 6d. (1s. 8d.)
1939-48	3s. (3s. 2d.)

INDEX TO ALL REPORTS AND MEMORANDA PUBLISHED IN THE ANNUAL TECHNICAL REPORTS, AND SEPARATELY—

April, 1950 R. & M. No. 2600. 2s. 6d. (2s. 7½d.)

INDEXES TO THE TECHNICAL REPORTS OF THE AERONAUTICAL RESEARCH COUNCIL—

December 1, 1936—June 30, 1939.	R. & M. No. 1850. 1s. 3d. (1s. 4½d.)
July 1, 1939—June 30, 1945.	R. & M. No. 1950. 1s. (1s. 1½d.)
July 1, 1945—June 30, 1946.	R. & M. No. 2050. 1s. (1s. 1½d.)
July 1, 1946—December 31, 1946.	R. & M. No. 2150. 1s. 3d. (1s. 4½d.)
January 1, 1947—June 30, 1947.	R. & M. No. 2250. 1s. 3d. (1s. 4½d.)

Prices in brackets include postage.

Obtainable from

HER MAJESTY'S STATIONERY OFFICE

York House, Kingsway, LONDON, W.C.2	423 Oxford Street, LONDON, W.1
P.O. Box 569, LONDON, S.E.1	
13a Castle Street, EDINBURGH, 2	1 St. Andrew's Crescent, CARDIFF
39 King Street, MANCHESTER, 2	Tower Lane, BRISTOL, 1
2 Edmund Street, BIRMINGHAM, 3	80 Chichester Street, BELFAST

or through any bookseller