



4-DEC 1954

MINISTRY OF SUPPLY

AERONAUTICAL RESEARCH COUNCIL
REPORTS AND MEMORANDA

Royal Aircraft Establishment
4-DEC 1954
LIBRARY

Water and Air Performance of Sea- plane Hulls as affected by Fairing and Fineness Ratio

By

A. G. SMITH, B.Sc., D.I.C., and J. E. ALLEN, B.Sc. (Eng.), A.M.I.Mech.E.

Crown Copyright Reserved

LONDON: HER MAJESTY'S STATIONERY OFFICE

1954

PRICE 7s 6d NET

Water and Air Performance of Seaplane Hulls as Affected by Fairing and Fineness Ratio

By

A. G. SMITH, B.Sc., D.I.C., and J. E. ALLEN, B.Sc.(Eng.), A.M.I.Mech.E.

COMMUNICATED BY THE PRINCIPAL DIRECTOR OF SCIENTIFIC RESEARCH (AIR),
MINISTRY OF SUPPLY

*Reports and Memoranda No. 2896**

August, 1950

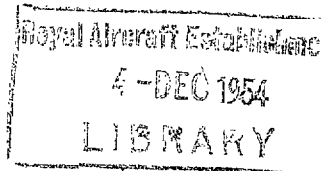

Summary.—An analysis is made of data on the variation of hull air drag with length/beam ratio and degree of local fairing, and of the maximum beam loading permitted for reasonable hydrodynamic performance. The effect of length/beam ratio on hull structure weight is also very briefly discussed.

Considerable reduction of surface-area drag coefficient is shown to be possible by extending the length/beam ratio above that in normal use, keeping the height and waterborne load constant. The length/beam ratio can usefully be defined in terms of the forebody-length/beam ratio. If this be increased from 3.5 to 7 the surface drag coefficient with an unfaired two step hull decreases from 1.6 to 1.35 times that of a body of revolution of the same length and maximum cross sectional area. With a transverse step faired with a 10 : 1 straight fairing in elevation the reduction is from the order of 1.15 to 1.10 and with a step faired in plan-form and elevation from the order of 1.20 to 1.15. The usefulness of the last step form is high because no applied ventilation is required to make it operationally acceptable. Also its drag could be further reduced if applied ventilation were permitted.

A similar order of total drag reduction is also possible if the forebody-length/beam ratio be increased so as to keep constant the product of the beam and the square of the forebody length. Under these conditions there is negligible increase of overall surface area, and the water performance for a given water load and hull height is reasonably constant as beam loading is increased from the order of $C_{d0} = 0.9$ at a forebody-length/beam = 3.5 to $C_{d0} = 3.7$ at 7.0. The limit to which the length/beam ratio can be increased will probably be determined by the minimum hull volume or width required for stowage purposes since this decreases fairly quickly, or seating width in passenger aircraft.

Hull weight is probably decreased a little with increase of length/beam ratio when the product of the beam and the square of the forebody length is kept constant.

Charts are given to help in the selection of the best hull form for any given design conditions. From these may be estimated dimensions, air drag, and the maximum beam loading to give a reasonable standard of water performance.

1. *Introduction.*—Considerable evidence has become available in recent years on the air and water performance of seaplane hulls on the basis of which it has been found possible to reassess the possible reduction of air drag consistent with little or no loss of water performance or increase of structure weight.

This evidence confirms that the air drag of a given hull depends primarily on the degree of step fairing but also shows that in certain circumstances the fineness ratio is equally important. The air drag has been analysed and expressed in terms of that of standardised equivalent bodies of revolution for which drag coefficients are known. It has further been found possible to estimate

* M.A.E.E. Report F/Res/219, received 13th January, 1951.

2.2. *Aerodynamic Efficiency*.—For any one fineness ratio as previously defined, the aerodynamic efficiency for air drag has been analysed as follows :—

$$(a) \frac{\text{(Drag coefficient per unit surface of hull area)}}{\text{(Drag coefficient per unit surface of an equivalent body of revolution)}} = \frac{C_f}{C_{fB}}$$

$$(b) \frac{\text{(Drag coefficient per unit surface area of hull} \times \text{surface area)}}{\text{(Drag coefficient per unit surface area of a standard body of revolution} \times \text{its surface area)}}$$

or

$$\sigma = \frac{C_f \cdot H}{C_{fB} \cdot B_s}$$

The first of these drag criteria measures the efficiency (or cleanness) with which a given hull has been faired, the second the overall efficiency with respect to fairing and reduction of surface area (both including the effect of fineness ratio).

The equivalent body of revolution is defined as that having the same overall length and maximum cross-sectional area as the hull. The surface area and distribution of cross-sectional area with length of the body of revolution are assumed similar to those of the R.101 airship shape given in Ref. 9. The drag coefficients are taken from the same source.

The standard body of revolution is arbitrarily chosen to be one equivalent to the average hull by contemporary standards as used in the American tests, i.e., $l_f/b = 3.45$. The corresponding value of $(l_f + l_a)/b$ is 6.0, l/b is 6.8 and the equivalent body of revolution fineness ratio 6.4. This standard body of revolution has a total drag very little different from that for optimum fineness ratio for the same volume⁹, and is considered to be of more practical value.

3. *Details of Air Drag Analysis*.—3.1. *Aerodynamic Cleanness (Figs. 1 and 2)*.—The full analysis of American and British tunnel test results is given in Appendix I. This tabulates the data used and explains the correcting assumptions that have been made to allow for discrepancies between the sets of results and also between the results and the calculated streamline body drag⁹. The British tests were made on isolated hulls, the American both on hulls mounted on a wing and isolated hulls. The American results have been corrected to give hull drag in the absence of wing interference.

It is shown in Appendix I that there is a difference between the surface drag coefficients as calculated⁹ and as measured in wind tunnels. The measured value is the greater, by 11 per cent in the National Physical Laboratory Compressed Air Tunnel and 8 per cent in the N.A.C.A. tunnel. These differences have little influence on the relative cleanness results but have an important bearing on the allied problem of extrapolating results to full-scale conditions.

Figs. 1 and 2 illustrate the variation of hull cleanness with fineness ratio, degree of step fairing, chine fairing and camber of the centre-line. Fig. 3 summarises drag data as measured in the N.P.L. Compressed Air Tunnel and Figs. 4 to 7 inclusive give drawings of the hulls used in all tests.

3.1.1. *American data*.—The scope of the American N.A.C.A. tests is summarised briefly in the following table:—

Reference	Hulls	Fairing, etc.	Remarks
T.N. 1305 ⁴	4 of constant l_f^2/b . l_f/b from 3.45 to 8.64	Step unfaired and also with 9:1 fairing	21% t/c wing. No body of revolution
T.N. 1306 ⁵	Second hull of Ref. 4 series only. $l_f/b = 5.2$	Series of 3 planing tail shapes	Planing tail hulls 18% t/c wing. No body of revolution
T.N. 1307 ⁶	Second hull of Ref. 4 series only. $l_f/b = 5.2$	Range of step and chine fairings	18% t/c wing. Body of revolution
T.N. 1686 ⁷	The 4 hulls of Ref. 4	All with unfaired steps	Without wing. No body of revolution
RM LSH11 ⁸	2 additional hulls of Ref. 4 constant l_f^2/b series of $l_f/b = 11.5$ and 17.2	Unfaired steps	Useful summary of the whole series

3.1.2. British data.

Reference	Hulls	Fairings, etc.	Remarks
A.R.C.3409 ¹⁰	Transverse main and aft steps. $l_f/b = 2.9$	Steps unfaired	No wing. Zero incidence only. Basic body of revolution and also one with up-cambered after-body
A.R.C.3794 ¹¹	Transverse main and aft steps. $l_f/b = 2.9$	Both steps faired to various degrees in elevation	
A.R.C.7784 ¹²	Pointed plan form main and aft steps. With fin and with and without cabin. $l_f/b = 3.2$	Range of fairings in plan and elevation	No wing. Range of incidence. Streamlined body included fin and cabin.

3.2. *Total Hull Drag*.—The results of the comparison of total drags with those of an arbitrarily chosen standard body of revolution are shown in Fig. 8. The drag data used are identical with those used for the cleanness analysis and have been corrected in the same way. The hull surface area data are taken from the original reports and the surface areas of the equivalent bodies of revolution are assumed to be that of the basic R.101 airship shape for which data are given in Ref. 9.

3.3. *Hull Surface Area, Volume and Leading Dimensions*.—Hull surface area has been analysed on the assumption that it can be simply expressed as

$$H = 2(\text{overall length}) \times (\text{height} + \text{beam}) \times \text{constant},$$

volume as

$$V = (\text{overall length}) \times (\text{height}) \times (\text{beam}) \times \text{constant},$$

and maximum cross-sectional area as

$$A = (\text{height}) \times (\text{beam}) \times \text{constant}$$

where the three constants vary with forebody-length/beam ratio. Results based on the data of Refs. 4 to 8 are given in Fig. 9. The corresponding overall (length/beam), (length from bow to aft-step/beam) and (height/beam) ratios are plotted against forebody (length/beam) in Fig. 10. Some additional data for contemporary hulls have been added to these figures.

3.4. *Estimation of Hull Series of Constant Volume*.—The data for the hull series of varying fineness ratio but constant volume have been deduced from the N.A.C.A. coefficients for a mean Reynolds number of 17×10^6 and were interpolated from the fineness ratio variants for the unfaired and faired step condition of Ref. 4, assuming that other changes of shape were small in comparison. Analysis in terms of total drag was then made as in section 3.2, and the results were given in Fig. 8.

4. *Results of Air Drag Analysis*.—It is clear from Figs. 1, 2 and 8 that the reduction of drag with increase of fineness ratio is very valuable providing hull surface areas and volumes can be kept to the minimum permitted by hydrodynamic considerations. At constant volume the reduction in total drag is fairly small because of the increase in surface area.

4.1. *Hull Cleanness.—Effect of Fineness Ratio*.—With the typical good hull with unfaired step, the ratio of the surface drag coefficient to that of the equivalent body of revolution is reduced from 1.6 to 1.35 and further to 1.2 by increasing the fineness ratio from 3.5 to 7.0 and finally to 9.0 (Fig. 2). The middle figure probably represents at the moment a maximum useful fineness ratio when the hull height is 2.5 times the beam and overall length 15 times the beam (Fig. 10).

Effect of Step Fairing.—This reduction in drag with fineness ratio is comparable with that obtained with a faired plan-form step at normal fineness ratio. It follows that with a good step fairing in plan and elevation, there should be little difficulty in obtaining cleanness ratios of 1·10 for a reasonable fineness ratio of the order of 6.

The American tests confirm the aerodynamic merit of the step faired in plan form and elevation (see Fig. 3). The cleanness ratio is improved from 1·5 to the order of 1·2 for the orthodox British hull and from 1·5 to 1·22 on American hulls of forebody-length/beam ratio 5·2. The American step is double the depth of the British and yet the drag reduction is considerably less, even for the American best straight step fairing. Recent British tests^{13,14} confirm the usefulness of this form of fairing and show that it may be possible to further increase its effectiveness if a straighter fairing could be used than was originally tested. This might, however, require applied ventilation, to be useful, hydrodynamically¹⁵. It should be noted that the extreme pointed form of this step in plan form has been used for some time for the aft step of contemporary British hulls.

The two British series of tests^{11,12} are consistent in demonstrating the big improvements possible with straight step fairing in elevation (see Fig. 3), the cleanness ratios being improved from 1·5 to the order of 1·2, but this result is considerably greater than that for the similar fairing on the American series, *i.e.*, 1·6 to 1·4. The difference may be because of the greater height/beam ratios of the American series, since increased fineness ratio is associated in practice with increased height/beam ratio. The conclusions of Ref. 16, based on the evidence available prior to 1937, indicate that the step drag is a function of the ratio of the step area to the total cross-sectional area. It would follow that step drag would be less for high hulls for similar step-depth/beam ratios. All tests confirm however that nearly all the step drag can be eliminated with a comparatively short straight fairing.

Effect of Hull Camber.—Turning up the tail, *i.e.*, introducing hull camber to lift the tail unit clear of spray, probably increases the drag the order of 10 per cent for contemporary hulls. Available data, examined in Appendix I, shows that the increment of drag of a streamlined body varies approximately linearly with degree of camber, camber being defined as the ratio of the tail height above the centre-line of the uncambered body divided by the total length. Little useful data are available on actual hulls, what there is being suspect because of the low Reynolds number of test. If, for example, the aft step is inadequately faired into the counter, there may be breakaways introduced with camber which apparently increase the camber effect, particularly in tests at low Reynolds number.

Effect of Chines.—The drag of chines is of the order of 3 per cent, if these are designed to fair into the local direction of airflow, but can be large if causing local breakaway either at the bows or step region. Compressed Air Tunnel tests on the *Princess* hull¹⁷, which uses a step faired in plan form and elevation, showed that in the chine region at the step discontinuities in the water lines caused the airflow to break away and increased the hull drag the order of 15 per cent. The N.A.C.A. tests indicate that fairing the chines and steps reduced the surface drag coefficient of the hull with $l_f/b = 5·2$ from 1·26 to 1·08 times the body of revolution surface drag coefficient. It is unlikely that much of this is due to step fairing because this had already been eliminated by a long straight fairing. The apparently large chine effect may be the result of large local breakaways as in the *Princess* case on this particular basic hull form.

Overall Cleanness.—It is interesting to note here that the drag of the worst hull considered in this report is good compared with that of hulls used in the 1930's, when cleanness ratios of 2 to 2·5 were quite common¹⁶.

4.2. *Total Drag.*—The total drag determines the usefulness of the gain in cleanness. It depends therefore on the changes of surface area caused by changes in fineness ratio and local fairing. Comparison with the total drag for the body of revolution equivalent to the orthodox hull of forebody-length/beam ratio 3·45, Fig. 8, shows that in fact the reduction in overall drag

with fineness ratio increase is of the same order as in cleanness for the $l_f^2 b$ series of hulls, but is small for the constant volume series. This is because the surface area is fairly constant in the former case up to an l_f/b of about 7, but in the constant-volume series it increases quite rapidly.

4.3. *Scale Effect.*—The scale effect measured is best illustrated by Fig. 3. Both British and American tunnel results confirm that the transition is at or very near the bow for Reynolds numbers greater than the order of 15×10^6 . Whether or not the drag coefficient will continue to decrease with increase of Reynolds number up to full-scale values of 200×10^6 is not known from wind-tunnel or full-scale flight tests, but evidence is available from ship resistance tests. Full-scale tests on the *Shetland* show that quite reasonable drags are in fact obtained^{18,19} at a hull Reynolds number of about 200×10^6 . Recent British tests on a hull with carefully prepared surfaces in the Compressed Air Tunnel show that the curve of drag coefficient against Reynolds number is parallel to that for turbulent skin-friction from 15×10^6 to 60×10^6 (Ref. 17).

The present state of knowledge in the analogous ship problem has been well explored in Ref. 20, which gives values for the friction coefficients of smooth surfaces measured by Kempf up to Reynolds numbers of 450×10^6 . Schoenherr, in America, plotted a large number of skin-friction coefficients, measured in ship tanks against Reynolds number, and derived an empirical law, *viz.*,

$$\frac{0.242}{\sqrt{C_f}} = \log_{10}(R_H \cdot C_f)$$

applicable to smooth bodies, and agreeing with Kempf's values. For application to actual ships, Schoenherr proposed a constant roughness allowance of 0.0004 on C_f , also based on experimental evidence, up to $R_H = 2000 \times 10^6$. Other laws have been proposed, *e.g.*, by Falkner (Ref. 21), but it is still not decided by the national ship-testing authorities as to which should be generally accepted. It is difficult to decide which formula is of greatest merit, as all suffer from the drawback of requiring an empirical roughness allowance. The real importance of this ship-resistance information in terms of this report is that the continued decrease of C_f with Reynolds number has experimental confirmation and that good empirical laws for smooth surface drags exist.

It is suggested that in extrapolating to full-scale, the law of Schoenherr be used for the present, together with a roughness allowance. Ref. 16 suggests that the roughness correction will be of the order of 12 per cent for medium-size hulls. Estimates are probably best made on the basis of Ref. 22 until further information is available.

5. *The Effect of Fineness Ratio on Hydrodynamic Performance and Beam Loading.*—It has been concluded that large aerodynamic drag reductions are possible without loss of hydrodynamic performance if the fineness ratio can be increased such that $l_f^2 b$ remains constant. This condition implies that there is a large reduction of beam with increase in forebody length for the same all-up weight, which entails big increases in beam loading.

Putting

$$C_{A_0} = \Delta_0/wb^3$$

$$l_f^2 b = \text{constant}$$

$$C_{A_0} \propto \frac{\Delta_0}{w} (l_f/b)^2.$$

The increase in beam loading is therefore quite outside established practice for orthodox hull design and it is clear that the past tendency to think in terms of a beam-loading coefficient of the order of 1.0 for hulls or 1.5 for floats is not applicable for finer hulls with the equivalent water performance. Absolute values to the maximum beam loadings anticipated as used with the fine hull series have therefore been estimated, starting from a datum based on acceptable contemporary standards.

The constant in the above relationship between C_{d0} and l_f/b has been found by analysing the operating design conditions of known seaplanes in terms of the beam loading and fineness ratio found satisfactory in practice and so establishing the maximum useful beam loading for a given forebody-length/beam ratio.

The limiting hydrodynamic design condition for propeller-driven seaplanes is usually the spray clearance from the propellers, especially in rough water. Limitations because of spray impact on wing, flaps and tailplane, and high hump drag generally come in at the same time in sheltered water but often a little earlier in rough water. For the purpose of this analysis the propeller spray clearance has been taken as the criterion, partly because some analytical work has already been done. A rational analysis is given in Ref. 23 where it is demonstrated that

$$C_z/C_{d0} \propto \frac{C_{d0}^{1/3}}{(l_f/b)^{2/3}} \propto \left[\frac{A_0}{l_f^2 b \cdot w} \right]^{1/3}$$

where C_z = height of spray at propeller disc above the tangent to the keel at the main step.

For the purposes of this report known data have been analysed in the alternative but possibly less general form

$$C_z \propto \left[\frac{C_{d0}}{l_f/b} \right]^{2/3}$$

so as to separate out the loading variable. The data are tabulated in Table 1 and plotted in Fig. 11. The spray heights are not very accurate, being mainly observed under non-steady conditions, and in other cases arbitrarily equated to the lowest heights of the edge of the propeller disc. In practice the effect of slipstream is important, lifting up spray into the propellers and on to the wings at high slipstream velocities²⁴.

From examination of the results plotted in Fig. 11 it has next been arbitrarily assumed that a reasonable datum loading condition satisfying known design achievements is $C_{d0} = 1.0$ when $l_f/b = 3.60$. The limiting loading conditions for different fineness ratio at constant $l_f^2 b$ follow and are illustrated in Fig. 12. At $l_f/b = 3.45$, the starting point for the American Tank Series, the limiting beam loading is 0.92 which is shown to be also typical of contemporary hull designs by the specific points plotted in Fig. 12 from Table 1. This figure also shows that except for special purposes, high loading designs generally lie on or higher than this line, the line being therefore conservative in tendency.

The beam loading for the hull series of constant volume and height has also been plotted in Fig. 12. The calculated values show it to vary approximately linearly with l_f/b and the line has been drawn through the same datum or endpoint at $C_{d0} = 1.0$. It is clear that the loading in this series becomes less severe as the fineness ratio increases, *i.e.*, the hulls become cleaner hydrodynamically. This means that from the seaworthiness viewpoint the hull heights could have been reduced. This line may be taken as defining a lower useful limit of beam loadings.

For jet or ducted fan-driven seaplanes the maximum beam loading criterion can be assumed to be unchanged for similar drag characteristics but reductions of hull height become possible because spray clearance is less critical. It is thought that tailplanes can always be lifted fairly clear or strengthened where necessary against spray impact and that wing trailing edges with retracted flaps probably form a limiting design factor. These can also be strengthened against transient broken spray impact.

It has been assumed so far that the spray and water force characteristics will not be affected appreciably by afterbody changes so long as the ratio of afterbody to forebody length is kept constant. The change of porpoising stability with increased beam loadings and afterbody length ratio resulting from the $l_f^2 b$ assumptions does however require investigation, detailed attention being given to the relative shapes of the afterbody and forebody wake. It is not anticipated that the modifications which may be necessary will appreciably alter the main conclusions of this report based on aerodynamic considerations.

But it is important to appreciate the limitations of the analysis of hydrodynamic performance in terms of l_f^2b and spray height. The l_f^2b law would appear to satisfy the physical condition that in the speed range up to the hump attitude the hull approximately satisfies the requirement that it displaces the same volume of water whatever the beam loading without the water-line rising to any extent too near the bows. Preferably the water-line should be such that the wetted surface does not extend forward of the straight keeled uniform cross-section part of the forebody. If the rising keel portion is wetted there will be rapid increases of both water pressure and drag components such that both higher spray and drag result.

6. *The Effect of Fineness Ratio on Hull Structure Weight.*—It has been shown²⁵ that for the same performance (speed, range, payload) a rough rule is that the effect of one per cent increase in overall structure weight is equivalent to 10 per cent increase in hull drag. It is therefore of obvious importance to avoid even a small increase of hull structure weight with increasing fineness ratio otherwise the hull drag reduction will be more than nullified. Rough calculations have been made in America²⁶ for the series of hulls tested, starting from a specific project weight distribution in which the hull-weight/all-up weight was 0.13. The load factor was kept constant. Allowance was made for the change of load distribution, particularly bending moment with length, and the detailed variations of 62½ per cent of the total hull weight estimated. The mean result has been assumed applicable to the whole hull. At constant l_f^2b hull weight is reduced from unity at a fineness ratio of 3.45 to 0.93 at 6.0 and 0.92 at 8.0, Fig. 13.

As a check, a rough estimate has been made using the methods and data given in Ref. 27. It is assumed that for typical British hulls of $l_f/b = 3$ to 3.5

$$\frac{\text{Hull weight}}{\text{All-up weight}} \text{ (per cent)} = 0.27w_s^{3/2} + 910(l_f b h/W)^{2/3}$$

where w_s is the wing loading in lb/sq ft.

The first term is for material in the bottom plating, frames, etc., of which the weight is proportional to impact velocity, the second is for material of minimum gauge, mainly the skin covering the stiffeners. For a typical large flying boat of 300,000 lb all-up weight, this gives a hull structure weight of 10.7 per cent, of which 60 per cent is in the first term and 40 per cent in the second. The effect of fineness ratio has been calculated by assuming that the bottom weights varied as the bottom plan area and the minimum gauge material as the surface area. Results, Fig. 13, at constant l_f^2b show reductions of weight of the same order as the American calculations, e.g., from unity at $l_f/b = 3.45$ to 0.90 at $l_f/b = 6$ and 0.87 at $l_f/b = 8.0$. At constant volume the weight increases slowly.

The structure weight reduction should be increased in practice to some extent because recent investigations in Britain show that there may be some relief in load factor for high beam loading, because the chines become immersed before the maximum reaction is obtained and this reaction is then smaller than it would have been with the larger beam. American investigations show the same tendency but to a greater extent. There is in addition a major reduction of angular acceleration resulting from impact²⁸.

The application of a high length/beam ratio to a specific project has been described in Ref. 29. It was concluded that a detail design study by an aircraft firm would be very desirable to check the general inferences from the approximate estimates of the effect of l_f/b on structure weight made in the report. In the particular case of high-flying turbo-jet passenger flying boats, the problem is complicated by pressurisation, the effect of which on the comparison of Fig. 13 is not known.

7. *Conclusions.*—The possible field of application of seaplanes is greatly extended because as a result of the information made available on the effect of hull fineness ratio on water and air performance the seaplane designer is given considerably greater freedom of choice in hull design. The designer can tailor the hull design to suit payload requirements, seating disposition and so on and know that both very good water and air performance can be achieved without carrying

excessive volume or weight. In fact, it should now be possible to design a hull for any purpose with very low air drag, particularly if payload requirements allow the use of a long fine hull. It is important to note that it is not concluded that fine hulls should be used on all occasions but that the fineness ratio can be selected to suit the conditions. Further, it is very advantageous to use the higher fineness ratio whenever possible, especially from the point of view of good open sea landings, and low air drag. It should also now be possible to design efficient jet-propelled or high-performance seaplanes with performances equal to that of the land plane at much lower weights than before where excessive hull size and its associated drag has been a deterrent in the past.

7.1. *Hull Aerodynamic Cleanness.*—The cleanness, defined as the ratio of the drag coefficient per unit area to that of the equivalent body of revolution of the same length and maximum cross-sectional area, is shown to depend in order of importance on :—

- (a) degree of step fairing
- (b) amount of turn-up aft of the main step or camber
- (c) chine fairing.

This ratio is 1.5 to 1.6 for unfaired hulls of contemporary design (forebody-length/beam 3 to 4) but can be reduced to the order of 1.15 with straight fairings on a transverse step, or 1.20 with a step faired in plan form and elevation. Increase of forebody-length/beam ratio to about 6 will reduce it to about 1.10 in the former and 1.15 in the latter case. The transverse step and straight fairing design will require some applied ventilation in operation ; the faired plan-form step will not in its present form. However, the latter could probably be further improved if ventilation were applied to be at least as efficient as the former.

7.2. *Total Hull Air Drag at Constant Water Performance.*—The total drag depends also on the efficiency with which the surface area is kept down. It is shown that for the same height and load on water, by reducing the beam so as to keep the square of the fore-body length times the beam constant, the length/beam ratio can be increased without increase of surface area. There is then no appreciable loss of water performance although tank and full-scale tests are necessary to check the porpoising stability so that the full gain in drag reduction can be achieved under these conditions. There is, however, a loss of volume and this will probably decide the maximum length/beam ratio possible for a given design. In passenger-carrying flying boats seating width will also impose a restriction on the choice of length/beam ratio.

If it is not possible to reduce the volume for stowage or other reasons, then small gains in air drag can be made by using a longer length/beam ratio but keeping the volume and height constant, but at the expense of an increase in structure weight.

Corrections for scale effect on air drag depend on assumptions made for roughness and finish, but tunnel data still show a consistent falling off of drag coefficient with Reynolds number up to 60×10^6 and ship data up to 450×10^6 , the rate being parallel to that for smooth turbulent friction conditions.

7.3. *Hull Structure Weight.*—The hull structure weight is expected to be reduced a little by the use of higher length/beam ratios, keeping $l_f^2 b$ constant, because of reduction of both bottom surface area and loading factor. There is no likely gain however if the beam cannot be decreased to the full extent permitted by water performance because of volume limitations. The maximum normal and angular water impact accelerations are likely to decrease with high beam loading.

7.4. *Maximum Beam Loading and Design Data.*—Charts are given of some data on maximum beam loading, surface areas and leading dimensions, hull heights for spray clearances, and how these change with fineness ratio. In particular, the maximum beam loading varies as $(l_f/b)^2$ for $l_f^2 b$ constant, *i.e.*, for constant hydrodynamic performance. A representative datum value is $C_{A0} = 1.0$ for $l_f/b = 3.60$.

LIST OF SYMBOLS

l_f	Forebody length from point of main step to bow
l_a	Afterbody length from point of main step to aft step
$L = l_a + l_f$	
l_c	Length of counter, from aft step to stem
b	Maximum hull beam at chines
$(l_f + l_a + l_c)/b$	Overall-length/beam ratio
l	Overall length (bodies and hulls)
h	Hull height
C_f	Surface-area drag coefficient of hulls
C_{fB}	Surface-area drag coefficient of body of revolution (tunnel)
C_{fC}	Surface-area drag coefficient of body of revolution (calculated)
$\kappa = C_f/C_B$	
$\sigma = C_f \cdot H/C_{fB} \cdot B_s$	
H	Wetted surface area of hull
B	Wetted surface area of equivalent body of revolution
B_s	Wetted surface area of standard body of revolution
A	Cross-sectional area of hull
V	Hull volume
R_H	Reynolds number based on hull total length
$C\Delta_0$	Static beam loading coefficient Δ_0/wb^3
Δ_0	Load on water at rest
w	Density of water (64 lb/cu ft sea water)
C_z	Spray height measured normal to keel datum/beam.

REFERENCES

<i>No.</i>	<i>Author</i>	<i>Title, etc.</i>
1	K. W. Clark and D. Cameron	Wind-tunnel and tank tests on the drag of seaplane hulls. A.R.C. 3143. May, 1937.
2	K. S. M. Davidson and F. W. S. Locke ..	General tank tests on the hydrodynamic characteristics of four flying-boat hull models of differing length/beam ratio. N.A.C.A. Report 4F15. June, 1944.
3	J. B. Parkinson	Design criterions for the dimensions of the forebody of a long-range flying boat. N.A.C.A. Report 3K08. 1943.
4	C. C. Yates and J. M. Riebe	Effect of length/beam ratio on the aerodynamic characteristics of flying-boat hulls. N.A.C.A. Tech. Note 1305. June, 1947.
5	C. C. Yates and J. M. Riebe	Aerodynamic characteristics of three planing-tail flying-boat hulls. N.A.C.A. Tech. Note 1306. June, 1947.
6	J. M. Riebe and R. L. Naeseth	Effect of aerodynamic refinement on the aerodynamic characteristics of a flying-boat hull. N.A.C.A. Tech. Note 1307. June, 1947.
7	J. G. Lowry and J. M. Riebe	Effect of length/beam ratio on aerodynamic characteristics of flying-boat hulls without wing interference. N.A.C.A. Tech. Note 1686. September, 1948.
8	J. M. Riebe	Aerodynamic characteristics of flying-boat hulls having length/beam ratios of 20 and 30. N.A.C.A. RM L8H11. November, 1948.
9	A. D. Young	The calculation of the total and skin-friction drags of bodies of revolution at zero incidence. R. & M. 1874. April, 1939.
10	R. Jones, A. H. Bell and E. Smyth ..	Resistance measurements on seaplane hulls in the Compressed Air Tunnel. A.R.C. 3409. February, 1938.
11	R. Jones and A. F. Brown	Tests on a flying-boat hull with faired steps in the Compressed Air Tunnel. A.R.C. 3794. November, 1938.
12	R. Jones, A. H. Bell and A. F. Brown ..	Drag measurements on a model of a flying-boat hull in the Compressed Air Tunnel. A.R.C. 7784. June, 1944.
13	D. I. T. P. Llewelyn-Davies	Tank tests on a hull faired in plan-form and elevation. R. & M. 2708. May, 1945.
14	A. G. Smith, G. Fletcher, T. B. Owen and D. F. Wright	Towing-tank tests on a large six-engine flying-boat seaplane, to specification 10/46, <i>Princess</i> . Part I: General porpoising stability, trim and clearance. R. & M. 2641. January, 1948.
15	A. G. Smith	An examination of some problems of large seaplane design and methods of investigation. A.R.C. 9405. January, 1946.
16	W. Ribnitz	The air drag of seaplane floats and flying-boat hulls in free flight. RTP/TIB Translation GDC10/5076 T. ZWB Report U. & M. No. 536. June, 1938.
17	A. G. Smith, D. F. Wright and T. B. Owen	Towing-tank tests on a large six-engine flying-boat seaplane, to specification 10/46, <i>Princess</i> . Part II: Porpoising stability, spray and air drag tests, with improved step fairing, afterbody design and aerodynamic modifications. R. & M. 2834. November, 1950.
18	T. M. Chalmers	Note on the air drag of the Shetland DX 166 (revised). A.R.C. 9674. March, 1946.
19	C. M. Britland	Comments on A.R.C. 9674. A.R.C. 10,122. October, 1946.
20	Fifth International Conference of Ship Tank Superintendents. London. H.M. Stationery Office. September, 1948.
21	V. M. Falkner	A new law for calculating drag. <i>Aircraft Engineering</i> . Vol. 15, No. 169. March, 1943.
22	A. D. Young	Drag effects of surface roughness. <i>Aircraft Engineering</i> . September, 1939.
23	P. Crewe	Remarks on the generalised spray data of N.A.C.A. Tech. Notes 1056 and 1091. Saunders-Roe Report H/O/51. October, 1947.
24	J. E. Allen	Full-scale spray tests of a four-engined flying boat (Seaford) with special reference to propeller damage. A.R.C. 11,237. December, 1947.

REFERENCES—*continued*

<i>No.</i>	<i>Author</i>	<i>Title, etc.</i>
25	C. H. E. Warren	The case for the large high-speed seaplane compared with the land-plane. A.R.C. 9433. February, 1946.
26	S. Bencotter	Estimate of hull weight change with varying length/beam ratio for flying boats. N.A.C.A. RM L7F24. August, 1947.
27	A. G. Smith, C. H. E. Warren and D. I. T. P. Llewelyn-Davies	An investigation into the trends and problems of large seaplane design. A.R.C. 9243. November, 1945.
28	A. W. Carter	Recent N.A.C.A. research on high length/beam ratio hulls, <i>J. Aero. Sci.</i> March, 1949.
29	J. E. Allen and R. H. D. Forbes ..	A project design for a 150,000-lb turbo-jet civil flying boat. A.R.C. 13,285. July, 1950.
30	R. Jones, A. H. Bell and A. F. Brown ..	Experiments on the drag of streamline bodies in the Compressed Air Tunnel with a discussion of technique. A.R.C. 3373. February, 1938.
31	S. Goldstein (Editor)	<i>Modern Developments in Fluid Mechanics.</i> Vol. II, p. 506. The Clarendon Press, Oxford.
32	J. B. Parkinson, R. E. Olson, E. C. Draley and A. A. Luoma	Aerodynamic and hydrodynamic tests of a family of models of flying-boat hulls derived from a streamline body. NACA Model 84 series. N.A.C.A. Report 766. 1943.
33	J. M. Riebe and R. L. Naeseth	Aerodynamic characteristics of a refined deep-step planing-tail flying-boat hull with various forebody and afterbody shapes. N.A.C.A. Tech. Note 2489. November, 1948.

APPENDIX I

Analysis of British and American Tunnel Tests

1. *Introduction.*—The aim of the analysis is to compare measured hull-surface drag coefficients with those of defined equivalent bodies of revolution. The available data are all model scale and measured in different wind tunnels by different techniques at different Reynolds numbers. The hull data vary in an inconsistent manner with Reynolds number and in the American case are also only known over a very restricted range. In addition, the American data is also complicated by large wing interference which has had to be evaluated by limited tunnel tests for the hulls. The limited tunnel measurements of the drag of the streamline bodies are greater than the theoretical, by amounts varying greatly with Reynolds number. In the American tests there is also the complication of wing interference.

2. *British Data.*—These data obtained from the Compressed Air Tunnel of the N.P.L. are given first since they provide the more thorough examination of possible scale effect, only limited by the engineering standard of the tunnel, *e.g.*, high turbulence, finish of models, shrinkage of models under compression and so on.

The British systematic data on hulls are taken from Refs. 10, 11 and 12. The tests were made on models of the order of 5 ft long and details are tabulated in section 3.1.2.

The tests covered a hull Reynolds number range of from 2×10^6 to 60×10^6 , and were made with free transition. The measurements included different combinations of tunnel pressure and velocity. Data on streamline body drag is taken from these References and also Ref. 30.

2.1. Description of the Hull and Body Forms Tested.—The tests of Refs. 10 and 11 were made on the same basic hull shape, the former relating the surface-area drag coefficient to (a) that of a basic body of revolution of the same length and slightly less surface area (8.46 sq ft compared with 8.5 sq ft) and (b) that of the basic form with the tail turned up to keep the top line horizontal in side elevation, which had an equivalent camber of 7.1 per cent, *i.e.*, the turn up of the tail as a fraction of the total length. The hull form, Fig. 6, was orthodox at the time of the test, 1938, having a straight transverse main step and narrow transverse aft step, a short aft camber, an l_f/b of 2.9, L/b of 5.67 and a height equal to the beam. It was designed for beam loadings of the order of $C_{A_0} = 0.5$.

The tests of Ref. 12 were made with a new balance technique³⁰ and were extended to cover a range of incidence using a hull, Fig. 7, representative of later design, 1944, and including plan-form as well as elevation step fairings. The hull was tested with a representative fin and with and without a cabin. It had a pointed plan-form aft step, $l_f/b = 3.2$, $L/b = 6.7$, but again rather a low height by contemporary standards because of the design beam loading, $C_{A_0} = 0.7$. The basic streamline shape was in this case not a body of revolution but a derived fuselage shape including a cabin, fin and partially turned up tail. The surface areas are given as 8.5 sq ft for the hulls and 8.12 sq ft for the equivalent fuselage.

2.2. Results and Effects of Reynolds Number.—Measured data from Ref. 12, giving the effect of various fairings over a Reynolds number range are given in Fig. 3. The minimum drag attitudes are in the region of 2 deg to 3 deg at the keel at the step, but Fig. 3 gives results at 0.3 deg since these differ little from the minimum values and are more in line with those of Refs. 10 and 11. The effect of cabin and fin is shown to be negligible at the higher values of R_H and the effect of partial fairing of the chines for 0.17 length from the bows very small. All results given in this report refer to the hulls with unfaired chines.

Body of Revolution Drag.—A collection of surface drag coefficients of streamline bodies of revolution measured in the N.P.L. Compressed Air Tunnel is shown in Fig. 17 plotted against Reynolds number. The figure also includes theoretical flat plate and streamline body drags and measured cambered body drags. A tabular summary of important results and a comparison of shapes is given in Table 4. On most of the bodies the transition from partially laminar to wholly turbulent flow appears to be complete at and above $R_H = 20 \times 10^6$. Above this value the drag results would be expected to be reliable provided the models were very smooth³¹, and in fact the curves are very closely parallel to the theoretical lines. The drag of the streamline body of Ref. 12 does not show a similar trend, for although its slope is decreasing with increase of Reynolds number, it is much flatter than the rest. It is most probable that its behaviour can be attributed to extra roughness which is known to counter the decrease of C_f with increase of R_H *. The drag of this body consequently does not form a sound basis of comparison with the hulls of its series, which do not exhibit the reduced slope. The cleanness ratio, if based on this body, would appear to vary appreciably with the Reynolds number.

Camber Drag.—The Compressed Air Tunnel results are given in Fig. 17 for streamline bodies. The British tests show a progressive decrease of apparent camber effect from 15 per cent at $R_H = 12 \times 10^6$ to 6 per cent at R_H exceeding 25×10^6 . In the N.A.C.A. tests of Ref. 32, however,

* As an indication of the order of roughness required to give the effect shown, the percentage increase in the measured drag, corrected for camber, above the calculated smooth value has been compared to theoretical roughness curves derived from Nikuradse's work in Fig. 16.

on symmetrical and cambered streamline bodies of revolution there was no measurable increase of drag from 5 per cent camber for Reynolds numbers between 10 and 30×10^6 . Tunnel tests on the effect of camber generally show very conflicting results and it is very probable that the effect will depend on Reynolds number as this will determine the effect of unfavourable pressure gradients over the after portion of the body. Since the Compressed Air Tunnel results become sensibly parallel to the theoretical curves for smooth turbulent friction above $R_H = 20 \times 10^6$, they are used in preference to any other data at lower Reynolds number, *e.g.*, that of Ref. 1.

2.3. Choice of Streamline Body of Revolution Drag for comparison with Compressed Air Tunnel Hull Drags.—For the evaluation of the cleanness ratio as defined in section 2.2. (a) it is necessary to relate the hull drag coefficients to those of equivalent bodies of revolution. The drag behaviour of bodies of revolution in wind tunnels is known to be particularly sensitive to many variables such as turbulence, transition from laminar to turbulent flow régimes, and surface roughness. The tunnel drag measurements of the streamline ‘datum’ bodies of both American and British tests require very careful scrutiny to obtain a consistent method of analysis. It is also particularly important to relate the measured drag coefficients to a theoretical standard for two reasons,

- (a) the theoretical standard may be used as a basis for extrapolation to full-scale,
- (b) the theoretical values give a good guide to the nature of the behaviour of the models in the tunnel.

The theoretical standard adopted here is that of Ref. 9, which is perhaps the best established method of calculating the drag of smooth streamline bodies, taking account of fineness ratio, Reynolds number and transition. This method has the additional advantage over, for example, the method of using turbulent flat-plate drags, that the form drag is correctly allowed for in bodies of different fineness ratio.

The tunnel factor is obtained by using the measurements of either the R.101 shape or streamline body of Ref. 10 as representative of Compressed Air Tunnel conditions, but excluding the body of Ref. 12, because of its apparent roughness qualities, as shown by Fig. 17. The second body has a drag about 2 per cent greater than that of the R.101 shape, probably accounted for by differences in shape.

The R.101 results have been used since the calculated drag for bodies of revolution is based on this shape and full theoretical data are available for all fineness ratios, Reynolds numbers and transition positions. The measured value of drag with Reynolds number of this shape is closely parallel to that of the hull drag of Ref. 12 as well as the theoretical curves, and is about 12 per cent higher than the latter value. It will be seen that the comparable N.A.C.A. tunnel figure is 8 per cent higher than the theoretical value.

Results are given in Table 5 and Figs. 1 and 2, all being made at a Reynolds number of 40×10^6 which is chosen to be well clear of any transition movement effects.

In application to full-scale, it is recommended that the cleanness values as calculated above should be used in conjunction with the theoretical values of Ref. 9 and a roughness correction.

3. American Data.—The N.A.C.A. data on the effect of hull fineness ratio and fairing on a standard hull form are taken from Ref. 4 to 8. These tests were made in the N.A.C.A. Langley Field 7-ft \times 10-ft Wind Tunnel on hull models nearly 10 ft in length. The scope of the tests is tabulated in section 3.1.1. In addition tests³³ have been made on hulls with deep steps faired in plan form and elevation and with planing tails.

The lines of these American hulls are shown in Figs. 4 and 5 and geometrical data, including volumes, surface areas, etc., and aerodynamic results are in Table 2.

3.1. *Reynolds Number, Transition and Measurements Made.*—A range of Reynolds number and hull incidence was covered and measurements were made of lift, drag and side force, and pitching and yawing moments.

Measurements were made at three Reynolds numbers for the four hulls of Refs. 4 and 7, *viz.*, $R_w/10^6 = 1.25, 2.45$ and 3.4 (*see* footnote) corresponding to mean values for $R_H/10^6$ of approximately 9, 18 and 25. The two very narrow hulls of Ref. 8 were tested at two values of $R_w/10^6, 1.3$ and 2.9 or $R_H/10^6 = 20$ and 24 .

The tests were all made with transition fixed at 5 per cent of the hull length and in addition the tests of Ref. 4 were made with transition free. The transition was fixed by means of a band of roughness $\frac{1}{2}$ -in. wide, consisting of approximately 0.008-in. diameter carborundum particles. The drag, transition free, was of the order of 6 to 8 per cent less than with transition fixed. For this analysis only the minimum drag, transition fixed, is used. The minimum drag occurs between 2 deg and 3 deg incidence at the tangent to the keel at the main step.

3.2. *Hull-Wing Interference.*—The earlier tests ^{4, 5, 6} were made on hulls mounted on a representative wing and on the wing alone. The hull drag was obtained by difference and includes any hull-wing interference drag. The measured hull + interference drags were less than accepted values for hulls alone and the tests were repeated later on isolated hulls⁷. These tests showed that the hull-wing interference drag was large and negative, of the order of 25 to 30 per cent of the drag of the hull with unfaired steps. All later N.A.C.A. hull-drag results have been quoted both with and without wing interference⁸.

3.3. *Streamlined Body-Wing Interference.*—In the tests of Refs. 6 and 33 drag and lift measurements were also made of a streamline body of circular cross-section when attached to wings of respectively 18 and 21 per cent thickness-chord ratio. Its ordinates are given in Table 4. Its drag includes wing interference and the value of this has been estimated by the following method for comparison with the hull drags without wing interference. The relevant drag coefficients, based on wing plan area (S_w), for the four hulls of Refs. 4, 6 and 7 are plotted in Fig. 15 against wing thickness-chord ratio.

It is assumed that the wing-body interference is mainly a function of the vertical position of the wing relative to the body, the wing incidence setting and thickness chord ratio, and the diameter of the top circular cross-section of the body. Fig. 14 gives front elevations of the series of hulls, the streamline body and the datum wings. The diameter of the streamline body, 12.964 in., is almost identically the same as that of hull number 213, *i.e.*, 12.91 in. and it is assumed that the interference drags are identical, the wings being very nearly at the same height and at 4 deg incidence. This implies that the lower part of the body, or hull, does not contribute any significant amount to the interference, which is probably associated mainly with pressure changes round the root intersections.

It will be seen that there is a direct measurement of the hull-wing interference drag for the 21 per cent wing tested in Ref. 33 but not for the 18 per cent wing of Ref. 6. This result only has been used to obtain the tunnel figure of the streamline body alone, *i.e.*,

C_{fB} , with wing interference	0.0018
Wing interference drag correction (from Fig. 15) referred to body's surface area	0.0013
C_{fB} , body alone	0.0031

The interference drag with the 18 per cent t/c wing has been assumed to make body drags without interference agree and the resulting faired curve appears reasonable compared with the measured results.

The corrected value is 8 per cent greater than the theoretical value for streamline bodies.

The reports quote Reynolds number (R_w) based on the wing chord of a hypothetical flying boat. In the present report all Reynolds numbers are referred to the overall hull or body length (R_H).

3.4. *Choice of Streamline Body Drag for comparison with Hulls.*—A limitation of the American test results, from the point of view of this analysis, is the lack of information on scale effect. Admittedly some hulls were tested at three Reynolds numbers but this evidence cannot be considered to be of the same merit as the more thorough N.P.L. work. The hull drag, with change of R_H , follows that of the calculated bodies of revolution in some instances, but in others shows no decrease with increase of R_H . It has therefore been assumed that the N.A.C.A. test results can be relied on to give a measure of the effect on drag of changes in fineness ratio and fairing but that the evidence on the effect of scale is insufficiently reliable to refute the N.P.L. results.

Therefore, the comparison of hulls and bodies is made only at $R_H \approx 17 \times 10^6$ which is the only value at which a value of the streamline body drag can be deduced. In order to relate the hulls of different fineness ratio to the equivalent body of revolution, it has been necessary to assume that the drags of these bodies, if measured in the N.A.C.A. tunnel, would vary in the same manner as that calculable by Ref. 9.

The results of the cleanness calculations for the American tests are given in Tables 2 and 3.

TABLE 1

Propeller Spray Clearance Data for some Boat Seaplanes

Aircraft	Weight lb	Max. beam b ft	C_{D0}	l_f/b	C_z	$\frac{C_z}{C_{D0}^{1/3}}$	$\frac{C_{D0}^{1/3}}{(l_f/b)^{2/3}}$	$\frac{C_{D0}^{2/3}}{(l_f/b)^{2/3}}$
<i>Sunderland</i>	60,000	9.79	1.00	3.36	0.95	0.95	0.44	0.44
	50,000		0.835		0.95	1.01	0.42	0.39
<i>Seaford</i>	75,000	10.75	0.95	3.21	0.84	0.86	0.435	0.44
<i>Shetland</i>	120,000	12.5	0.96	3.50	0.80	0.81	0.42	0.40
<i>Lerwick</i>	35,000	8.4	0.92	3.04	0.89	0.82	0.46	0.45
<i>Saro 37</i>	5,700	4.13	1.285	3.75	1.06	0.98	0.445	0.48
<i>Saro 45 (Princess)</i>	320,000	16.5	1.10	3.81	0.88	0.85	0.43	0.44
<i>Catalina</i>	30,000	10.17	0.45	2.44*	0.75	0.97	0.425	0.33
	35,000		0.52		0.90	1.12	0.44	0.35
<i>Coronado</i>	68,600	10.5	0.925	3.0	1.03	1.06	0.47	0.45
<i>Martin PBM-1</i>	68,000	8.52	1.21	3.70	0.89	0.84	0.44	0.47
<i>Martin JRM-1</i>	110,000	13.5	0.70	3.57*	0.635	0.715	0.382	0.34
<i>Martin XPB27-IR</i>	148,500	13.5	0.94	3.32*	0.84	0.86	0.44	0.43
<i>Blohm und Voss 222</i>	68,000	10.1	1.03	4.88	0.79	0.77	0.35	0.35

* l_f measured to step centroid of area.

TABLE 2

The Effect of Fineness Ratio on the Cleanness of Hulls. N.A.C.A. Tests

References	4 and 7				8	
Model number	213	203	214	224	239	240
L/b	6	9	12	15	20	30
l_f/b	3.45	5.18	6.91	8.53	11.52	17.23
t ft	9.19	9.72	10.15	10.51	11.02	11.82
A (cross-sectional area) .. sq ft	1.57	1.26	1.04	0.903	0.757	0.59
W (wetted area) sq ft	31.5	31.8	32.3	33.1	34.6	37.0
V (volume) cu ft	8.59	7.49	6.68	6.16	5.62	4.84
d/l equivalent streamline body ..	0.15	0.13	0.11	0.10	0.09	0.07
Camber per cent	9.1	8.6	8.2	7.9	7.6	7.1
Relative volume per cent	100	87.2	77.8	71.7	65.4	56.3
R_H (millions)	16.7	17.6	18.4	19.2	20.0	21.4
$C_{D \min}$ * based on fixed wing area ..	0.0093	0.0079	0.0072	0.0068	0.0066	0.0066
$C_{f \min}$ * based on hull wetted area ..	0.0054	0.0045	0.0041	0.0038	0.0035	0.0033
$C_{D V^*}$ based on $V^{2/3}$	0.0406	0.0378	0.0372	0.0376	0.0381	0.0421
$C_{f B}$ of streamline body (tunnel) ..	0.00327	0.00315	0.00308	0.00302	0.00297	0.00292
$C_{f \sigma}$ of streamline body (calculated) ..	0.00303	0.00292	0.00285	0.00280	0.00275	0.00270
Cleanness ratio† κ						
Unfaired step	1.65	1.43	1.33	1.26	1.18	1.13
Step faired 9 : 1	1.49	1.28	1.19			

* Without wing interference, transition at $0.05L$, unfaired steps.

† Referred to tunnel value of streamline body drag coefficient.

TABLE 3

The Effect of Degree of Fairing on Cleanness Ratio Surface Drag Coefficients Measured by the N.A.C.A. (Ref. 6)

Only minimum values are quoted, all at $R_H \approx 17 \times 10^6$.

Transition fixed at $0.05l$ throughout. Hull $l/b = 5.2$.

Condition	C_f	α
Hull with unfaired step and chines	0.00450	1.43
Bow chines rounded	0.00427	1.35
9:1 straight elevation fairing	0.00404	1.28
Step completely faired	0.00398	1.26
Step completely faired and chines rounded	0.00393	1.25
Hull completely faired	0.00341	1.08
Streamline body of revolution of equivalent d/l , in tunnel*	0.00315	1.00
Theoretical value (Ref. 9) for streamline body	0.0029	0.92

* Hull-wing interference allowances as in Fig. 15.

TABLE 4

Leading Dimensions, Estimated and Measured Drags and Conditions of Test of Reference Streamline Bodies

Streamline body of Ref. No.	30	10	12	33
d/l	0.143	0.143	0.143	0.108
Fineness ratio l/d	7	7	7	9
Camber per cent	0	0	3.2	0
C_f	0.00305	0.00312	0.00320	0.00310
R_H millions	40	40	40	17
Boundary-layer transition	free, most probably at nose			Fixed at 0.05 length
$C_{f,c}$ (calculated)	0.00270	0.00270	0.00270	0.00288
Measured/calculated C_f	1.13	1.15	1.19*	1.08
Co-ordinates of streamline body	Diameter/Maximum diameter			
per cent length from nose				
0	0	0	0	0
5	0.45	0.61	0.47	0.51
10	0.65	0.79	0.64	0.72
15	0.77	0.88	0.77	0.86
20	0.86	0.93	0.86	0.92
25	0.92	0.96	0.92	0.97
30	0.96	0.93	0.96	0.99
35	0.99	1.00	0.99	1.00
40	1.00	1.00	1.00	1.00
45	1.00	0.99	0.93	0.99
50	0.93	0.97	0.95	0.93
60	0.89	0.87	0.82	0.92
70	0.75	0.74	0.67	0.81
80	0.58	0.54	0.48	0.65
90	0.33	0.29	0.25	0.38
100	0	0	0	0

* Includes 3 per cent due to up-cambered tail.

TABLE 5

*The Effect of Degree of Fairing on Cleanness Ratio :
 Surface Drag Coefficients Measured in the Compressed Air Tunnel (Ref. 12)*

All values refer to 0.3 deg incidence, unfaired chines and a Reynolds number $R_H = 40 \times 10^6$.
 See Fig. 3

Condition	C_f	κ
Hull with normal step	0.00460	1.51
Hull with 6 : 1 concave step fairing	0.00403	1.32
Step faired in plan form only	0.00390	1.28
Step faired in plan and elevation	0.00358	1.17
Step with straight 9 : 1 fairing	0.00343	1.13
Basic fuselage with turned up tail (3.2 per cent camber, cabin and fin)*	0.00320	—
Ref. 10—7.1 per cent cambered body	0.00330	1.08
Cambered body† derived from R.101	0.00314	1.03
Ref. 10—Symmetrical body	0.00312	1.02
R.101—Symmetrical body (basic)	0.00305	1.00
Theoretical value for streamline body	0.00270	(0.89)
Prandtl Schlichting flat plate turbulent value	0.00244	(0.80)

* Suspect model, see Appendix I.

† Assuming camber increment from A.R.C. 3409.

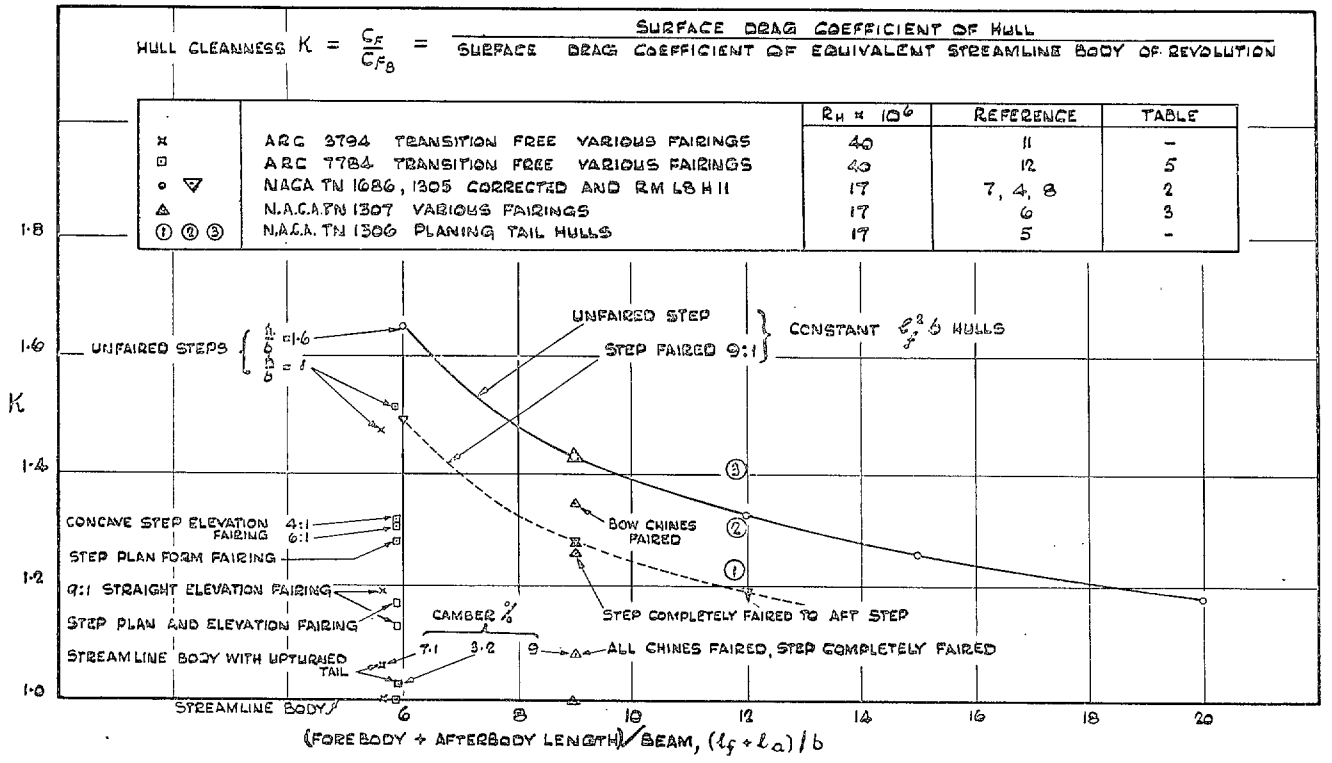

FIG. 1. Variation of hull cleanness ratio κ with $(l_f + l_a)/b$ and fairing.

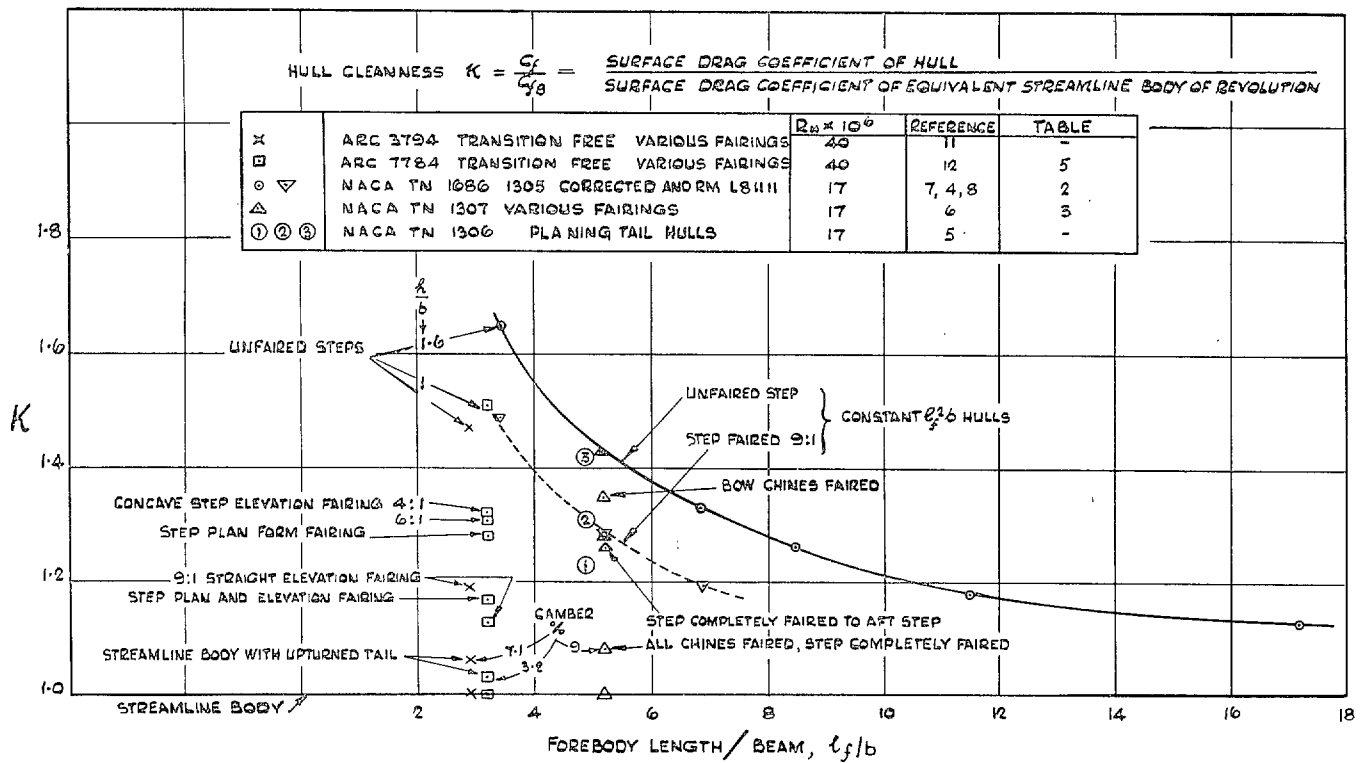
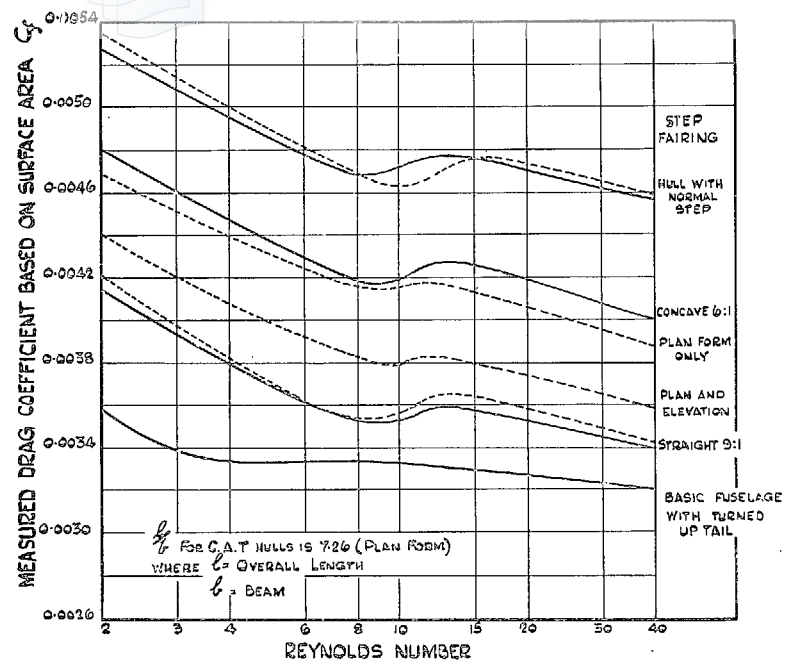

FIG. 2. Variation of hull cleanness ratio κ with l_f/b and fairing.



BASIC FUSELAGE: CIRCULAR CROSS SECTION: UPTURNED TAIL: CABIN

NORMAL STEP: UNFAIRED PLAN AND ELEVATION

CONCAVE FAIRING (c.f. SUNDERLAND)

PLAN FORM FAIRING

PLAN AND ELEVATION FAIRING (STREAMLINE)

STRAIGHT FAIRING

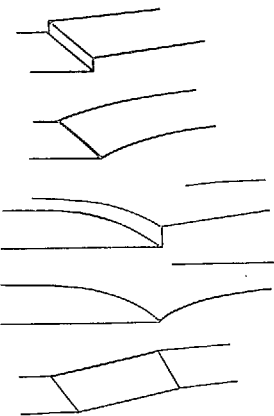

FIG. 3. Variation of hull-surface drag coefficient with Reynolds number for degrees of fairing. N.P.L. Compressed Air Tunnel tests. Ref. 12.

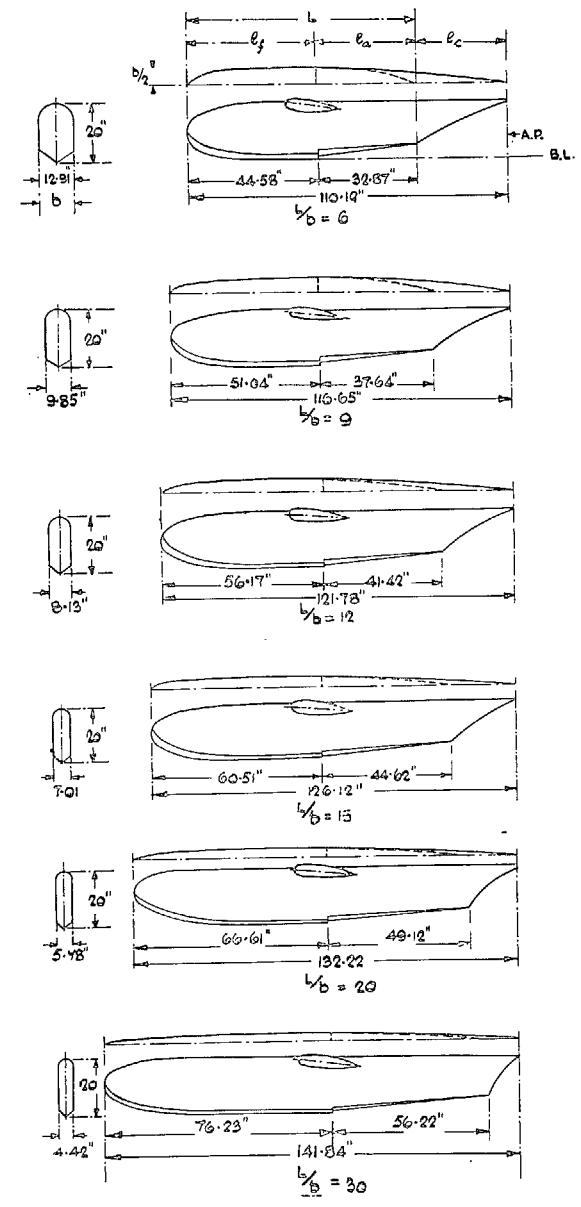

FIG. 4. Lines of Langley tank models of varying fineness ratio. Fig. 1 of Ref. 8.

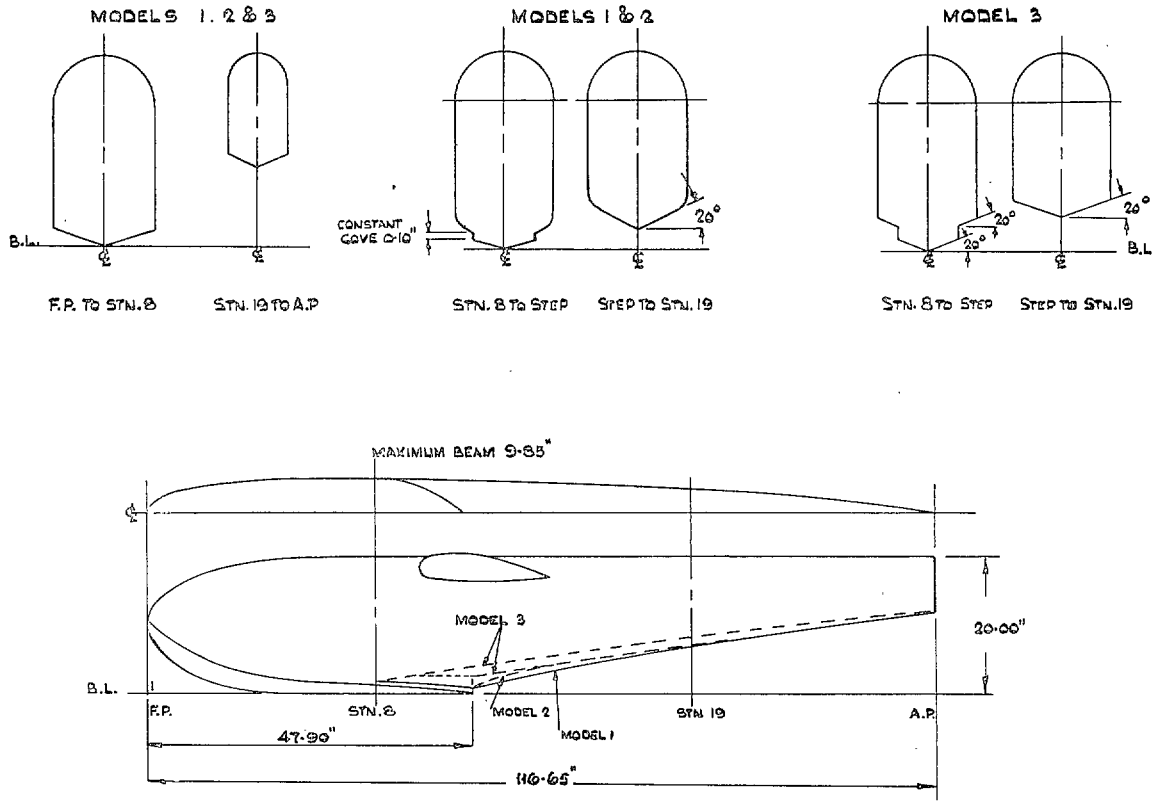

FIG. 5. Lines of Langley tank models with deep step faired in elevation and plan form. Fig. 1 of Ref. 5.

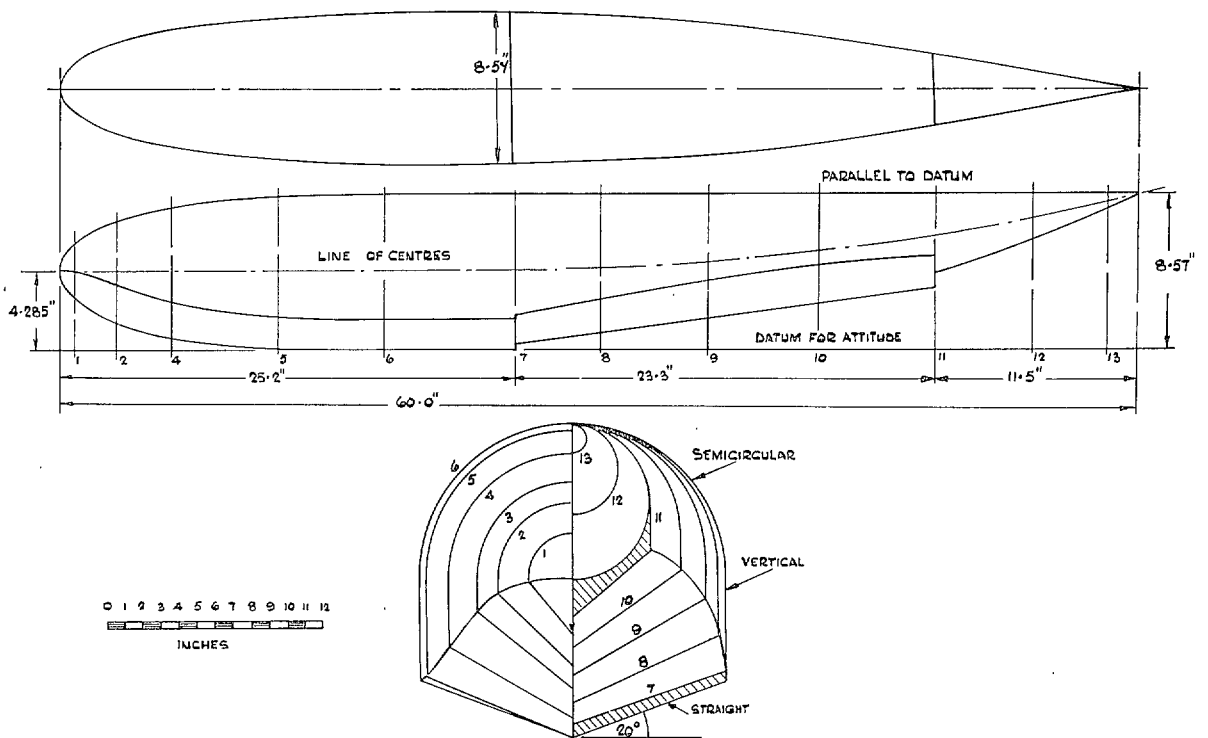

FIG. 6. Lines of unfaired hull of Ref. 10.

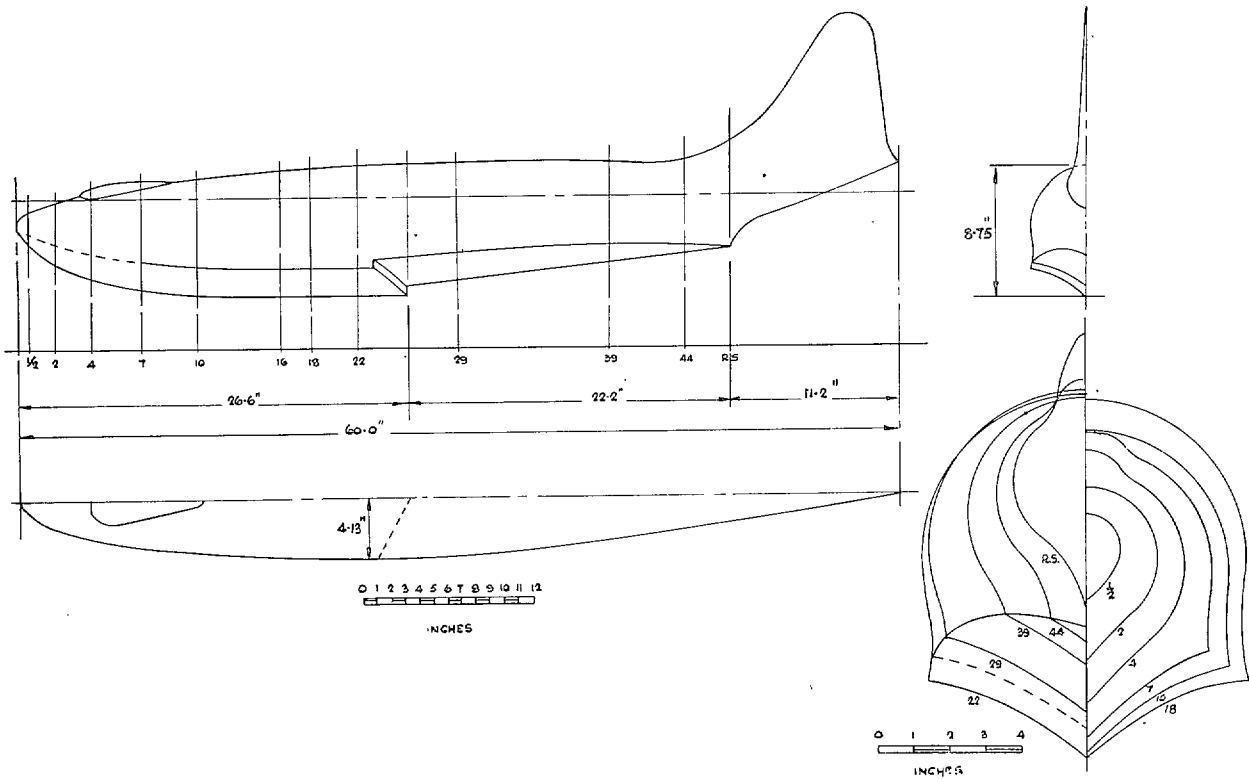

FIG. 7. Lines of unfaired hull of Ref. 12.

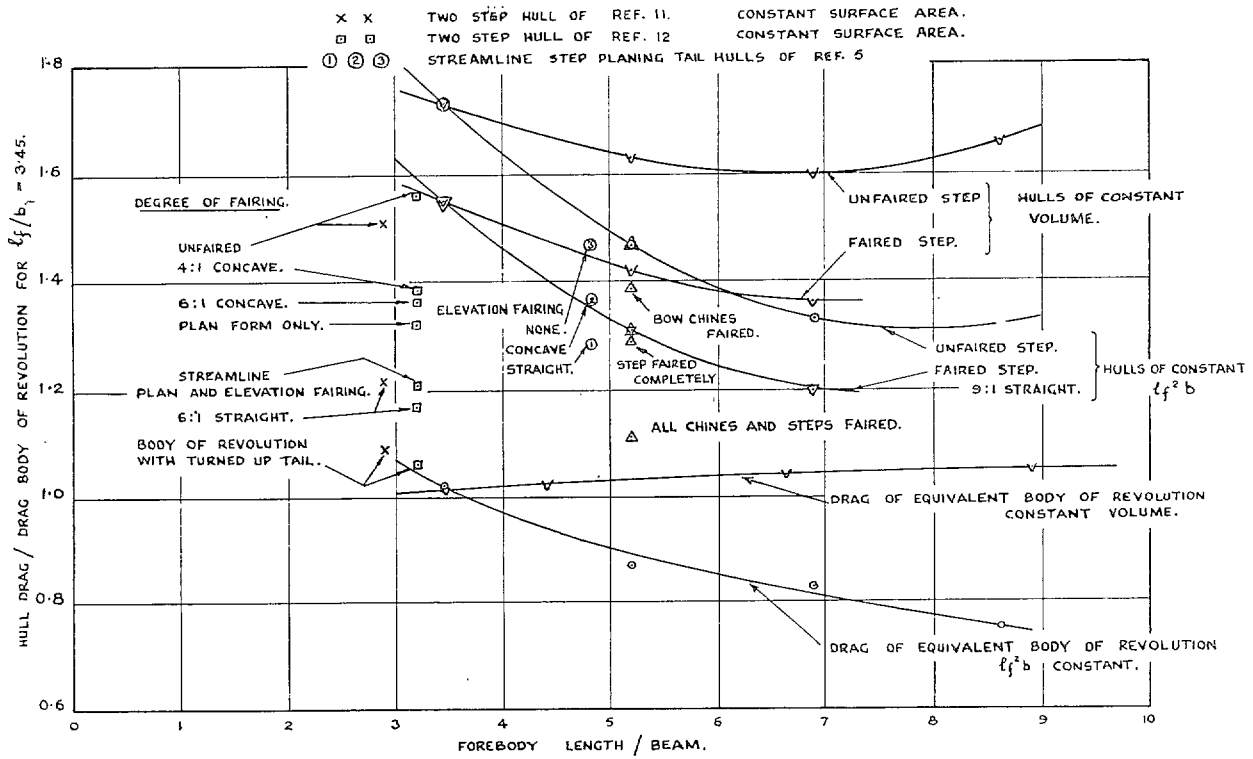

FIG. 8. Ratio of total drag of hulls to that of a standard body of revolution.

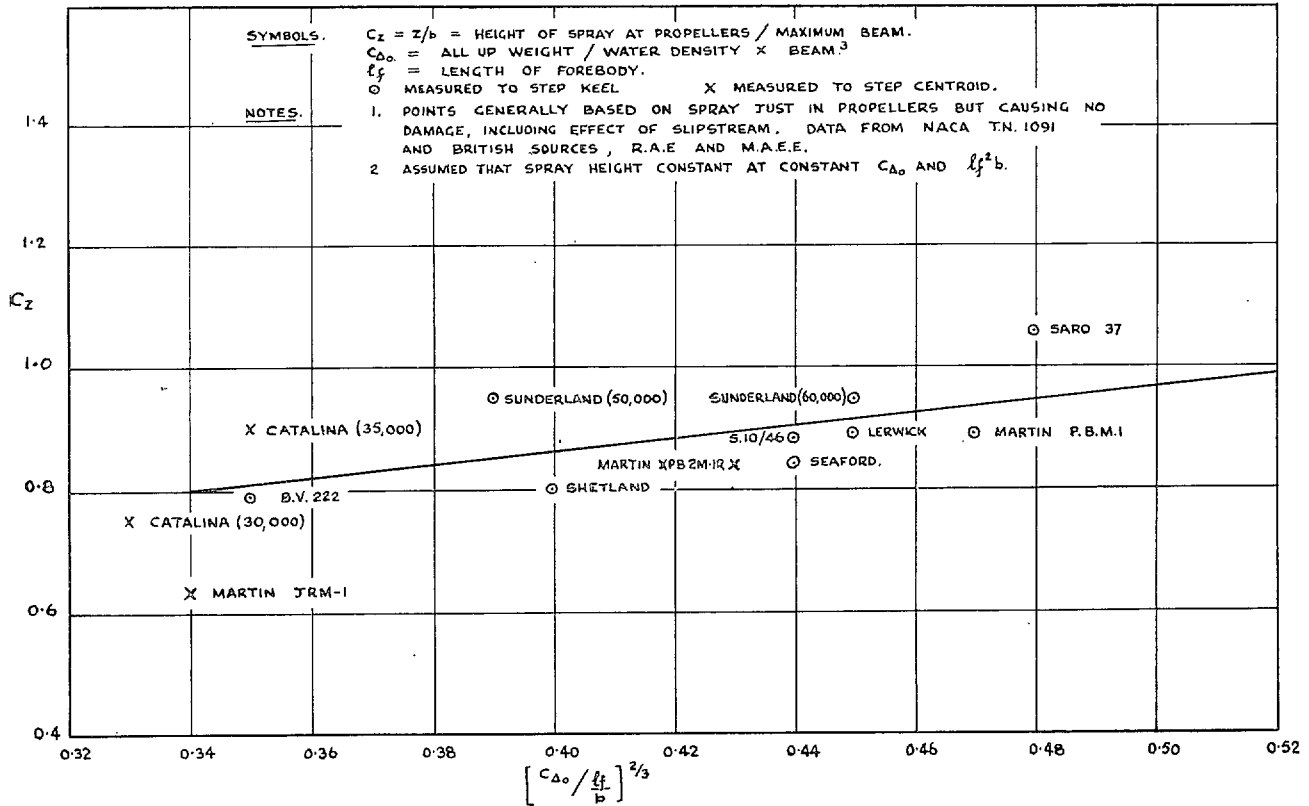

FIG. 11. Variation of spray height at propellers with beam loading and forebody-length/beam ratio.

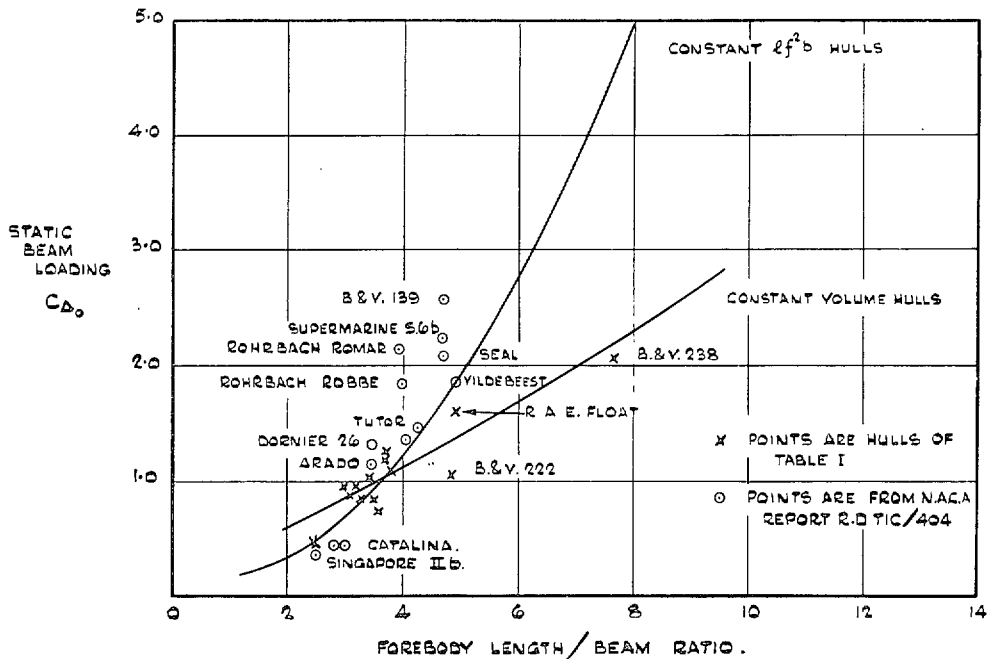
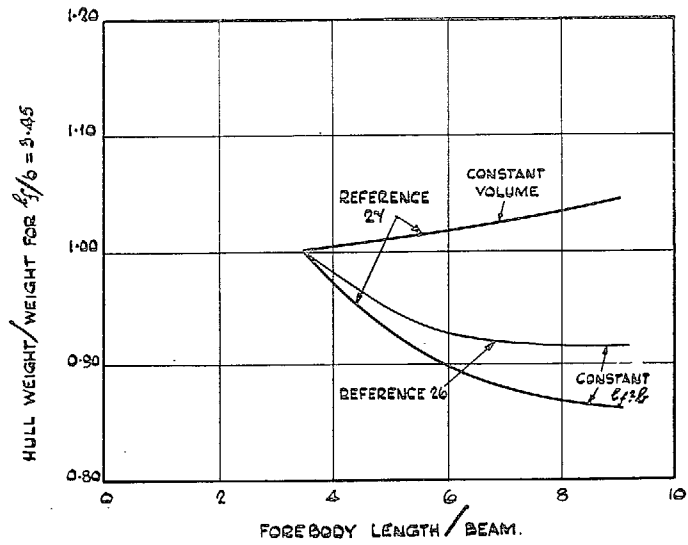
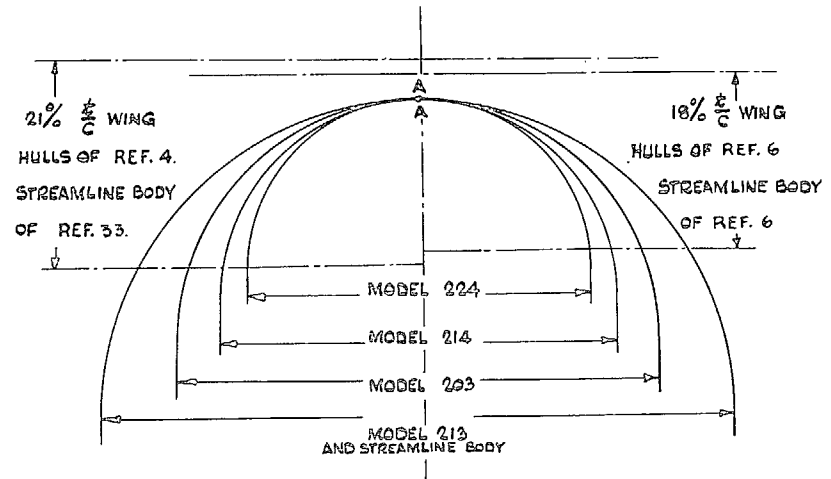

FIG. 12. Maximum useful beam loading and length/beam ratio for constant all-up weight and spray height.



NOTE: HULL STRUCTURE WEIGHT IS 10 - 12% A.U.W.

FIG. 13. Rough estimates of order of hull weight change with forebody-length/beam ratio at constant all-up weight.



Front elevation of hulls, streamline bodies and 'datum' wings.

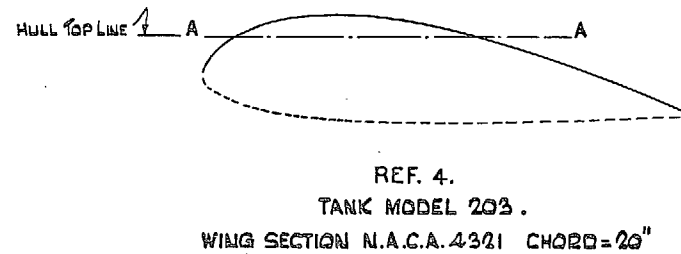
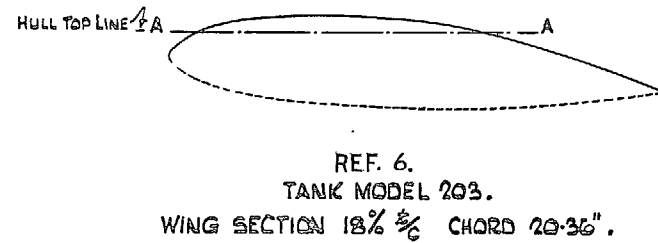

Side elevations of hulls, bodies and wings.

FIG. 14. Wing-body intersections, N.A.C.A. Tests.

(61782) WFL 17/680 K.9 9/54 HW.

27

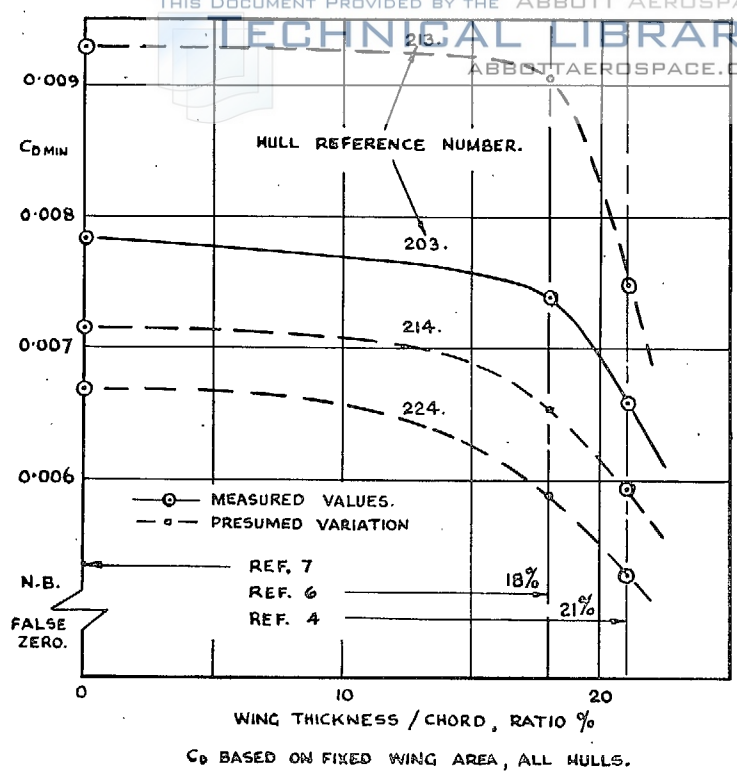

FIG. 15. Hull drags with and without wing interference.

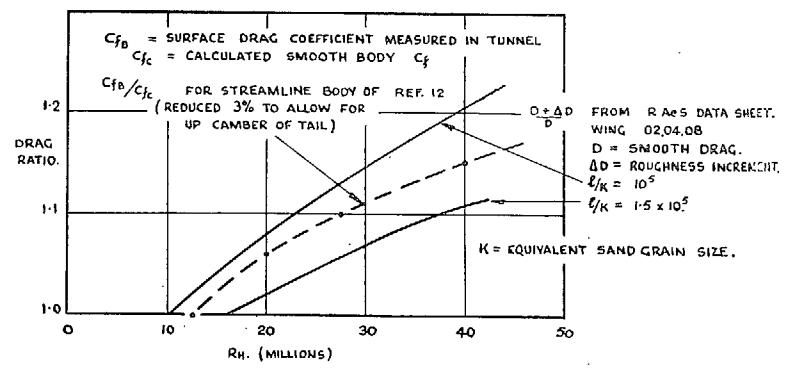

FIG. 16. Comparison of N.P.L. Compressed Air Tunnel model C_{fB}/C_{f0} and Nikuradse roughness ratio.

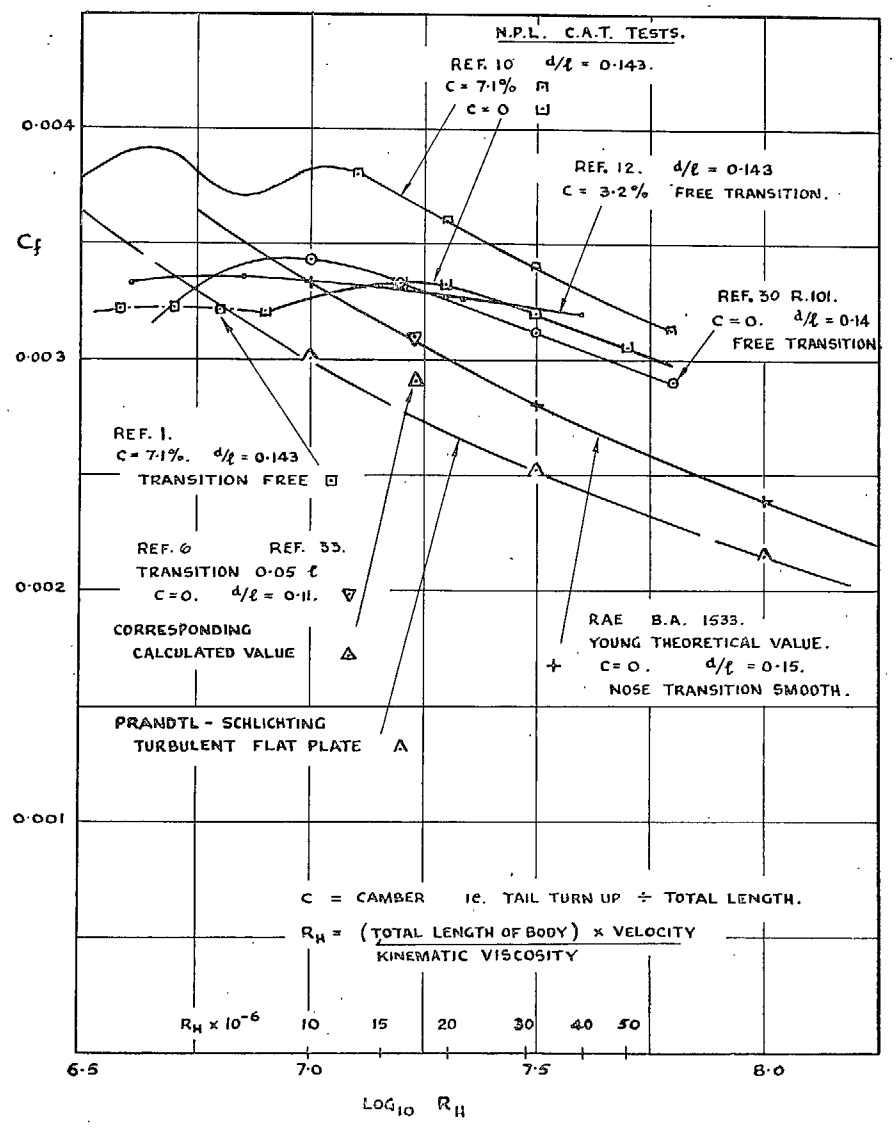

FIG. 17. Surface drag coefficients of streamline bodies of revolution.

PRINTED IN GREAT BRITAIN

Publications of the Aeronautical Research Council

ANNUAL TECHNICAL REPORTS OF THE AERONAUTICAL RESEARCH COUNCIL (BOUND VOLUMES)

- 1936 Vol. I. Aerodynamics General, Performance, Airscrews, Flutter and Spinning. 40s. (41s. 1d.)
 Vol. II. Stability and Control, Structures, Seaplanes, Engines, etc. 50s. (51s. 1d.)
- 1937 Vol. I. Aerodynamics General, Performance, Airscrews, Flutter and Spinning. 40s. (41s. 1d.)
 Vol. II. Stability and Control, Structures, Seaplanes, Engines, etc. 60s. (61s. 1d.)
- 1938 Vol. I. Aerodynamics General, Performance, Airscrews. 50s. (51s. 1d.)
 Vol. II. Stability and Control, Flutter, Structures, Seaplanes, Wind Tunnels, Materials. 30s. (31s. 1d.)
- 1939 Vol. I. Aerodynamics General, Performance, Airscrews, Engines. 50s. (51s. 1d.)
 Vol. II. Stability and Control, Flutter and Vibration, Instruments, Structures, Seaplanes, etc. 63s. (64s. 2d.)
- 1940 Aero and Hydrodynamics, Aerofoils, Airscrews, Engines, Flutter, Icing, Stability and Control, Structures, and a miscellaneous section. 50s. (51s. 1d.)
- 1941 Aero and Hydrodynamics, Aerofoils, Airscrews, Engines, Flutter, Stability and Control, Structures. 63s. (64s. 2d.)
- 1942 Vol. I. Aero and Hydrodynamics, Aerofoils, Airscrews, Engines. 75s. (76s. 3d.)
 Vol. II. Noise, Parachutes, Stability and Control, Structures, Vibration, Wind Tunnels. 47s. 6d. (48s. 7d.)
- 1943 Vol. I. Aerodynamics, Aerofoils, Airscrews. 80s. (81s. 4d.)
 Vol. II. Engines, Flutter, Materials, Parachutes, Performance, Stability and Control, Structures. 90s. (91s. 6d.)
- 1944 Vol. I. Aero and Hydrodynamics, Aerofoils, Aircraft, Airscrews, Controls. 84s. (85s. 8d.)
 Vol. II. Flutter and Vibration, Materials, Miscellaneous, Navigation, Parachutes, Performance, Plates and Panels, Stability, Structures, Test Equipment, Wind Tunnels. 84s. (85s. 8d.)

Annual Reports of the Aeronautical Research Council—

1933-34	1s. 6d. (1s. 8d.)	1937	2s. (2s. 2d.)
1934-35	1s. 6d. (1s. 8d.)	1938	1s. 6d. (1s. 8d.)
April 1, 1935 to Dec. 31, 1936	4s. (4s. 4d.)	1939-48	3s. (3s. 2d.)

Index to all Reports and Memoranda published in the Annual Technical Reports, and separately—

April, 1950 - - - - - R. & M. No. 2600. 2s. 6d. (2s. 7½d.)

Author Index to all Reports and Memoranda of the Aeronautical Research Council—

1909-1949. R. & M. No. 2570. 15s. (15s. 3d.)

Indexes to the Technical Reports of the Aeronautical Research Council—

December 1, 1936 — June 30, 1939.	R. & M. No. 1850.	1s. 3d. (1s. 4½d.)
July 1, 1939 — June 30, 1945.	R. & M. No. 1950.	1s. (1s. 1½d.)
July 1, 1945 — June 30, 1946.	R. & M. No. 2050.	1s. (1s. 1½d.)
July 1, 1946 — December 31, 1946.	R. & M. No. 2150.	1s. 3d. (1s. 4½d.)
January 1, 1947 — June 30, 1947.	R. & M. No. 2250.	1s. 3d. (1s. 4½d.)
July, 1951.	R. & M. No. 2350.	1s. 9d. (1s. 10½d.)

Prices in brackets include postage.

Obtainable from

HER MAJESTY'S STATIONERY OFFICE

York House, Kingsway, London, W.C.2; 423 Oxford Street, London, W.1 (Post Orders: P.O. Box 569, London, S.E.1);
 13a Castle Street, Edinburgh 2; 39, King Street, Manchester 2; 2 Edmund Street, Birmingham 3; 1 St. Andrew's
 Crescent, Cardiff; Tower Lane, Bristol 1; 80 Chichester Street, Belfast, or through any bookseller