



MINISTRY OF AVIATION

AERONAUTICAL RESEARCH COUNCIL
REPORTS AND MEMORANDA

An Experimental Method for the Study of
the Impact between a Liquid Drop and a
Surface Moving at High Speed

By D. C. JENKINS, B.Sc., A.F.R.A.E.S., J. D. BOOKER, A.F.R.A.E.S.,
and J. W. SWEED

LONDON: HER MAJESTY'S STATIONERY OFFICE

1961

PRICE 10s. 6d. NET

An Experimental Method for the Study of the Impact between a Liquid Drop and a Surface Moving at High Speed

By D. C. JENKINS, B.Sc., A.F.R.AE.S., J. D. BOOKER, A.F.R.AE.S.,
and J. W. SWEED

COMMUNICATED BY THE DEPUTY CONTROLLER AIRCRAFT (RESEARCH AND DEVELOPMENT)
MINISTRY OF SUPPLY

*Reports and Memoranda No. 3203**

July, 1958

Summary.—A description is given of apparatus developed at the Royal Aircraft Establishment for the study of the impact between a liquid drop and a surface moving at speeds up to 3,500 ft/sec. Some results obtained are briefly described and other possible uses for the apparatus discussed.

1. *Introduction.*—The forward-facing surfaces of an aircraft or missile in high-speed flight through rain may suffer severe damage due to the impact of the raindrops. For the study of the mechanism causing the damage an experimental method has been developed by means of which the high-speed impact between single drops of water and a surface can be examined in detail. Impacts between surfaces and certain liquids other than water and also between surfaces and small solids can be produced by this method but in this report only the use of water is considered in detail.

There are considerable experimental difficulties in producing the impacts by accelerating water drops to high speeds and in the method described here the surface is projected against a suspended water drop. After impact the surface is decelerated in such a manner as to protect any mark made on it during impact.

2. *Experimental Method.*—A smooth-bore gun and an arrester tube are arranged on a common axis with a gap between the gun muzzle and the entrance to the tube. By means of a fine web a drop of water is suspended in front of the entrance to the tube on the common axis. A projectile, part of whose nose forms the impact surface, is fired by means of the gun to strike the drop. After the impact the projectile enters the arrester tube where it is decelerated, by being forced through a series of aluminium washers separated by distance pieces. The central hole in the washers is smaller than the diameter of the projectile but larger than the impact surface which is thus untouched during the deceleration period.

* R.A.E. Tech. Note Mech. Eng. 193, received April, 1955.
R.A.E. Tech. Note Mech. Eng. 256, received October, 1958.
R.A.E. Tech. Note Mech. Eng. 267, received February, 1959.

Two versions of the apparatus using this technique are described. One, based on a 1-in. bore gun using compressed gas as the propellant, has an effective speed range of 200 to 1,750 ft/sec. The other, based on a $1\frac{1}{4}$ -in. bore gun using an explosive charge as the propellant, has an effective speed range of 500 to 3,500 ft/sec.

3. *Description of 1-in. Bore Apparatus.*—3.1. *General.*—A diagrammatic arrangement is shown in Fig. 1 and the complete apparatus is illustrated in Figs. 2, 3 and 4.

The gun, working compartment and arrester system are mounted on a supporting beam beneath which the control panel and compressed-gas cylinders are suspended. The beam can be pivoted about the axis of a spindle situated approximately a third of the way along its length. This enables the gun to be fired either horizontally (Fig. 3) which is the normal position or vertically (Fig. 4) which may be required in special cases. The spindle rotates in bearings supported by tubular steel frames which are mounted on a cruciform base constructed of steel channel. The apparatus is locked in the horizontal or vertical position for firing.

3.2. *Gun.*—The gun consists of a 1-in. diameter smooth-bore barrel 2 ft long attached to a firing cylinder which is divided into two compartments separated by a fixed partition as shown in Fig. 5. The front chamber is sealed off from the barrel by the front valve which is shaped to give good gas flow characteristics. The seating surface of the valve is of hard rubber bonded to a steel disc to prevent its being dislodged by the gas flow on firing. The valve stem passes through an 'O' ring seal in the dividing wall between the two chambers and is attached to a piston in the rear chamber.

To operate the gun the front chamber is filled with compressed gas to the required pressure which, in conjunction with a spring acting on the rear face of the piston, holds the valve closed. Compressed gas is then admitted rapidly to the rear chamber by means of an electro-pneumatic valve whose quick opening and low pressure-drop characteristics have an important influence on the performance of the gun. The force due to the gas pressure acting on the relatively large area of the piston causes a rapid opening of the front retaining valve and the compressed gas stored in the front compartment is discharged into the barrel. For safety considerations the pressure in the front chamber is normally limited to 1,000 p.s.i. by means of a relief valve and the 'triggering' pressure normally used in the rear chamber is 310 p.s.i. In order to prevent premature firing due to leakage of gas either from the front chamber into the barrel or into the rear chamber, or past the electro-pneumatic valve into the rear chamber, bleed ports open to the atmosphere are provided in the barrel immediately behind the projectile and in the rear chamber. The bleed ports are closed by cocks operated by a lever just prior to firing.

3.3. *Working Section.*—This consists of a steel compartment 20 in. long, 12 in. wide and 10 in. high mounted on the main supporting beam and enclosing the 20-in. gap between the gun muzzle and the arrester tube. The side of the compartment nearest the control panel is in the form of a stout sliding door permitting access to the compartment, whilst the opposite side consists of a toughened glass window for observation purposes. The door operates a micro-switch which interrupts the firing circuit until the door is closed.

Two horizontal rails, running the full length of the compartment, allow the drop holder or other items to be located at any desired distance from the muzzle. The trip wires or photo-electric cells used for measuring the speed of the projectile may also be mounted in this compartment.

3.4. *Projectile Arrester.*—The system employed is shown diagrammatically in Fig. 6. The projectile is forced along the central core of a series of aluminium washers and spacer rings clamped between the upper and lower halves of a retaining tube and is brought to rest by expending its kinetic energy

in deforming the washers. A micro-switch operated by closing the two halves of the arrester tube interrupts the firing circuit until the tube is clamped shut.

Washers, with outside diameter 1.5 in. and inside diameter of 0.7 in. in aluminium to specification L.16 and of thickness 22 s.w.g. (0.028 in.), are normally used but other thicknesses may be used depending on the weight and velocity of the projectile. New washers are used for each shot.

4. *Description of 1¼-in. Bore Apparatus.*—4.1. *General.*—A diagrammatic arrangement is shown in Fig. 7 and the complete apparatus is illustrated in Figs. 8 and 9. The gun, blast tube, water-drop holder and arrester tube are mounted on a composite beam 21 ft long, constructed from two standard steel channels and spacers. The drop holder can be positioned as desired along a small rail spanning the 17-in. gap between the end of the blast tube and the entrance to the arrester tube. The beam, which weighs 600 lb complete with gun and arrester system, is free to slide parallel with the axis of the gun on bearing plates mounted on a steel base channel 23 ft long anchored to a concrete floor. Recoil is resisted by friction and a helical compression spring of 6,000 lb/in. rating at each end.

4.2. *Gun.*—The barrel is an Aden gun barrel with internal diameter enlarged to a smooth bore of 1¼ in. It is supported by a rigid mounting at the muzzle and at the other end by the breech block, into which it is screwed. The breech block is attached to the main beam by four bolts and its rear face butts against a block welded on to the beam. The breech body is screwed on to the rear of the breech block and consists of a hollow steel cylinder whose bore is a good fit on the 1-in. diameter cartridge case, which is inserted from the rear. Three different lengths of breech body are employed, the size being chosen to suit the length of cartridge in order to achieve good burning characteristics of the powder. The gun assembly is completed by the firing-pin unit. This consists of a steel breech nut, screwed on to the rear of the breech body, and the firing pin, insulated from the nut by means of polyethylene bushes, which is lightly spring-loaded so as to maintain electrical contact with the cap of the cartridge. A positive electrical lead from the firing box is plugged into the rear of the firing pin and the circuit is completed by a negative return lead plugged into the main beam.

To prepare the gun for firing the breech body is removed and a projectile is placed in the rear end of the barrel. The breech body is screwed on and a cartridge of the required charge weight is inserted into it. The firing-pin unit is screwed down until it firmly grips the rim of the cartridge. The firing leads are plugged in and the gun is fired using a regulation R.A.E. 24V D.C. system.

4.3. *Cartridge.*—I.C.I. Ltd. Engine Starter Cartridge Cases No. 2 Mk. 5 fitted with an electric detonator are used. These are filled by hand, using a small quantity of gunpowder G.20 as a primer and the required amount of Neonite as a propellant. The cartridges are cut to length and completed by a wad of cotton wool and a cardboard disc, retained in place by bending the lip of the case inwards. The maximum charge consists of 4 grammes of gunpowder and 24 grammes of Neonite.

4.4. *Blast Tube.*—The need for some form of blast deflector between the muzzle and the water drop was shown by trials with high-speed flash photography before the introduction of the blast tube. These showed that at certain velocities shatter of the drop occurred if it was positioned at distances less than 3 ft from the muzzle. As the entrance to the arrester tube had to be situated a short distance behind the water drop this meant that a gap of at least 4 ft was necessary between the muzzle and the arrester tube to avoid premature break-up of the drop and difficulty was experienced in making the projectile enter the arrester washers concentrically at that distance.

The blast tube was accordingly introduced to enable the drop to be positioned at a safe distance from the muzzle of the gun by acting as a guide for the projectile to ensure accurate entry into the arrester tube.

The blast tube is a slotted steel tube, 6 ft long, having the same inside diameter as the gun barrel and an outside diameter of $1\frac{3}{4}$ in. It is screwed on to the gun muzzle at one end and supported at the other end and midway along its length by adjustable mountings, which enable alignment with the axis of the gun to be maintained.

As the projectile moves along the tube the gases following it and the column of air preceding it are deflected sideways through the slots in the tube and do not disrupt the water drop or its web. This is seen in Figs. 10 and 11, which are high-speed flash photographs showing that 2-mm diameter water drops are intact immediately prior to being struck by projectiles travelling at 1,200 ft/sec and 3,000 ft/sec respectively.

The horizontal white streaks visible in Fig. 11 are made by particles of burning powder which follow the projectile leaving a trace on the film during the time, very much longer than the duration of the flash, in which the camera shutter is open.

4.5. *Projectile Arrester*.—The arrester system is an enlarged version of that employed on the 1-in. bore gun described in Section 3.4. The total length of the arrester tube is 10 ft, divided into three sections of equal length. The outside diameter of the washers is 2 in. and the bore 0.9 in. The thickness of the washers is graded from 26 s.w.g. (0.018 in.) at the entry of the arrester tube to 18 s.w.g. (0.048 in.) at a point some 4 ft from the entry, to reduce the rate of deceleration of the projectile and thus the danger of accidental damage to fragile specimens. New washers are used for each shot.

5. *Projectiles*.—5.1. *1-in. Diameter Projectiles*.—The arrangement of a typical projectile for carrying thick specimens is shown in Fig. 12. It consists of a hollow magnesium alloy body on to which is screwed a tapered nose of the same material which locates and retains the specimen. The specimen, which is 0.25 in. thick, may be of any material whose behaviour under impact with a water drop is to be examined. The total weight together with an aluminium specimen is approximately 15 grammes. Fig. 13 shows a typical projectile for carrying specimens of sheet form. These projectiles, although very light, are strong enough to withstand repeated use for a large number of times.

Although the projectiles described above are typical, other forms of projectile have been used for certain tests. A projectile 11 in. long and another weighing 130 grammes have been fired and recovered successfully.

5.2. *1 $\frac{1}{4}$ -in. Diameter Projectile*.—Fig. 14 shows a typical projectile consisting of a steel nose and moulded polyethylene body. This projectile, weighing 61 grammes complete with aluminium-alloy specimen, has been found the most suitable to withstand the high accelerating and decelerating forces and has been used successfully without undue damage at speeds up to 3,500 ft/sec.

Fig. 15 shows the slightly modified version of the projectile in which specimens of sheet form may be held.

6. *Drop Suspension*.—A fine web stretched across a ring is used for suspending the drop. This ring may be cut away locally to facilitate photographic observation of impacts. The web is formed with the fine threads drawn out from between the faces of two corks which have been lightly smeared with a solution of Perspex in aniline and then rubbed together.

With the web in a vertical plane the largest drop which can be suspended without tending to slide down the web is approximately 2.5-mm diameter as shown in Fig. 16. A horizontal web is required to support drops greater than 2.5-mm diameter and in this manner drops up to approximately 5-mm diameter can be supported but the distortion from a spherical shape is then considerable.

If the drop is suspended at a suitable distance from the muzzle of the gun it is intact when struck by the projectile. This is seen in Fig. 17 which shows a drop just prior to impact using the 1-in. gun. The web has been blown away leaving the drop unsupported and of approximately spherical shape. Figs. 10 and 11 show that in the case of the 1¼-in. gun, where the drop is positioned much further from the muzzle, no significant movement of the web occurs.

It has been found that if the drop is suspended too close to the muzzle of the gun premature break-up may occur before the projectile reaches it, as shown in Fig. 18. Fig. 19 shows an alternative form of premature break-up in which the drop is being blown into the shape of a hollow bag in the manner described by Lane¹. The possible effect on impact damage that may be caused by a drop that is prematurely broken up may be gauged by a comparison of Figs. 20 and 21. Fig. 20 shows the smooth indentation type of damage caused in a specimen of L.34 by the impact of a 2.5-mm diameter drop at 800 ft/sec. Fig. 21 shows the irregular type of mark made in L.34 at the same speed by a prematurely broken drop similar to that of Fig. 18.

7. *Drop Preparation.*—Water drops of the required size are produced by means of the calibrated micro-burette shown in Fig. 22.

In this burette a plunger operated by a fine screw thread displaces the required volume of water from a small cylindrical reservoir through a hypodermic needle. The pitch of the thread and diameter of the plunger have been chosen so that one complete turn of the operating drum ejects a volume of water equal to that of a 2-mm diameter drop. Other drop sizes can be obtained according to the number of turns given to the operating drum. The displaced water forms into a drop on the square-ground end of the hypodermic needle.

The holder with prepared web is placed on a mounting spigot which can be suitably registered under the hypodermic needle to ensure the desired drop positioning. The burette is lowered gently by depressing the button on the bridge piece until the drop makes contact with the web. The drum unit is then allowed to rise slowly under the action of the return spring whilst the drop remains attached to the web due to the differences in surface tension between web, drop and needle. The web holder complete with drop is then placed in position in the apparatus.

The micro-burette has been calibrated by weighing 30 drops of each size in a range of sizes between 1-mm and 2.5-mm diameter on a balance weighing to ±0.1 milligrams. The method employed consisted of weighing a small specific-gravity bottle empty and then with one drop inside. Table 1 shows the average volumes and standard deviations obtained for the range of drop sizes.

TABLE 1

Drop diameter (mm)	True volume (mm ³)	Number of turns of drum head	Average volume (mm ³ \bar{X})	Standard deviation (S)	$\frac{S}{\bar{X}}$
1.00	0.52	0.125	0.54	0.09	0.172
1.25	1.03	0.244	1.01	0.09	0.086
1.50	1.77	0.423	1.77	0.13	0.073
1.75	2.74	0.670	2.76	0.10	0.038
2.00	4.19	1.002	4.15	0.09	0.027
2.25	5.99	1.420	5.97	0.09	0.016
2.50	8.16	1.952	8.04	0.09	0.011

8. *Measurement of Projectile Velocity.*—The velocity is calculated using the measured time taken for the projectile to pass between two points a known distance apart. Either photo-electric cell or breaking-wire systems are used for this purpose. The $1\frac{1}{4}$ -in. apparatus is used on a firing range and standard firing-range timing equipment² is used. This equipment, however, is too bulky for use with the 1-in. apparatus for which a smaller set of equipment was made.

8.1. *1-in. Bore Apparatus.*—The two photo-electric cell units are situated $12\frac{1}{8}$ in. apart on one side of the projectile trajectory with the illuminating lamps on the other. The viewing system of the photo-electric cells consists of narrow slits giving a laminar field of view at right angles to the trajectory. The two signals produced as the projectile passes the cells are shaped and amplified and fed into a micro-second counter chronometer which measures and indicates the time interval between them.

For certain applications, such as photographic work, where slight marking of the projectile nose may be acceptable and the photo-cell lighting system cannot be used, an alternative method of timing is employed. Two wires, forming part of start and stop circuits respectively, are stretched across the path of the projectile at a known distance apart. The two signals produced as the projectile breaks the two wires in turn are fed into the amplifier and micro-second counter chronometer in the same way as for the photo-electric cell method.

Fig. 23 shows the circuit diagram of the velocity measuring system.

8.2. *$1\frac{1}{4}$ -in. Bore Apparatus.*—The two photo-cell units are placed on one side of the blast tube with the centres of their fields of view 34 in. apart and coinciding with slots in the blast tube as shown in Fig. 7. Plano-convex cylindrical lenses and 12V 36W lamps on the opposite side of the tube are used to produce beams of parallel light to illuminate the photo-cells.

The time interval between the two signals produced as the projectile interrupts each light beam in turn is measured on the counter chronometer. A breaking-wire timing system may be used with the counter chronometer instead of the photo-cell system if necessary.

9. *Gun Performance.*—9.1. *1-in. Gun.*—Fig. 24 shows the gun performance with two projectiles weighing 14.7 and 17.8 grammes respectively, using compressed air and compressed hydrogen as propellants. The projectile weighing 14.7 grammes including an aluminium specimen is the lightest practicable projectile which will withstand a large number of firings without damage.

For a given air-pressure a higher speed is obtained with the lighter projectile but a cross-over occurs at about 1,500 p.s.i. so that the maximum speeds attainable with the two projectiles are approximately the same, being 1,100 ft/sec for the lighter and 1,070 ft/sec for the heavier projectile. The fall in performance which occurs at the highest pressures can be prevented by increasing the pressure in the triggering circuit to the limit of 350 p.s.i. but no increase in the maximum velocity is obtained by doing so.

Fig. 24 also shows that the use of compressed hydrogen as propellant instead of air results in a considerable improvement in performance as would be expected on account of its lightness and higher acoustic velocity. A velocity of 1,550 ft/sec is obtained at 1,600 p.s.i. Although the maximum permissible operating pressure of the gun prevents extended tests, the shape of the performance curve suggests that higher speeds could be obtained at increased hydrogen pressures. A simple projectile weighing only 12.1 grammes designed for photographic work and without the extra weight entailed in carrying a specimen gave a speed of 1,750 ft/sec at 1,600 p.s.i.

9.2. *$1\frac{1}{4}$ -in. Gun.*—The gun will give velocities of from 500 ft/sec to 3,500 ft/sec with the projectiles described in Section 5.2, depending on the weight of charge used. The upper velocity is obtained

with a charge of 24 grammes of propellant and 4 grammes of primer, which is the maximum that can be employed without exceeding the breech design pressure. Although the apparatus may be used for velocities lower than 1,000 ft/sec it is usually more convenient to employ the 1-in. bore gun for this purpose.

10. *Applications.*—10.1. *General.*—Apart from water, solids, *e.g.*, ice and sand particles, and certain other liquids, *e.g.*, mercury, can with care be suspended on the web and this permits a more general study of impact phenomena. In the following paragraphs some water-drop impact results and some novel applications of the apparatus are briefly discussed.

10.2. *Water-Drop Impacts.*—Figs. 25 and 26 show the type of mark, resembling superficially that of a Brinell hardness test, made in a $\frac{1}{4}$ -in. thick aluminium-alloy specimen to Specification D.T.D.423B at 3,200 ft/sec. Figs. 27 and 28 show the type of mark made in a neoprene protective coating on a specimen at 2,800 ft/sec. The central mound, whose mid-point is level with the original neoprene surface, is surrounded by a zone where the thickness of the neoprene has been greatly reduced. This zone in turn is surrounded by a raised annular rim caused apparently by the flow of the impacting drop forcing the material radially outwards.

The apparatus provides a convenient means of studying impact phenomena photographically. Fig. 29 is a typical high-speed flash photograph of the normal impact between a 2-mm drop and a surface moving at 1,000 ft/sec showing the radial flow of the impacting drop.

10.3. *Calibration of an Airborne Raindrop Recorder.*—The 1-in. bore apparatus has been used to calibrate an airborne raindrop recorder in which a prepared surface is exposed to the rain. By fixing a sample of the prepared surface in the nose of the projectile and using various drop sizes and projectile velocities the relation between drop size, velocity and size of imprint made on the prepared surface was determined³. A similar calibration has been made for ice crystals in place of water drops using the apparatus in a cold chamber⁴.

10.4. *Break-up of Drops in an Air Blast.*—Air blasts of controlled speed can be simulated by using a long tubular projectile open at the front end and closed at the back end. A water drop entering the open nose of such a projectile is acted on by an air blast, the speed of which is taken to be the same as that of the projectile. These long projectiles are found to be readily caught without damage in the washer system, thus droplet sampling slides fixed inside the projectile are recoverable and can be used to study the break-up process of the drop. By making the projectile of transparent Perspex the break-up process can be photographed. Fig. 30 shows a 2-mm drop disintegrating inside a projectile travelling at 550 ft/sec.

Acknowledgements.—Thanks are due to Mr. W. R. Lane of the Chemical Defence Experimental Establishment for details of the web support technique.

LIST OF REFERENCES

<i>No.</i>	<i>Author</i>	<i>Title, etc.</i>
1	W. R. Lane	Shatter of drops in streams of air. <i>Industrial and Engineering Chemistry</i> . Vol. 43. p. 1312. 1951.
2	<i>Internal Ballistics</i> . H.M.S.O. 1951.
3	F. J. Bigg, I. I. McNaughtan and T. J. Methven	The measurement of rain from an aircraft in flight. (Unpublished M.o.A. report.)
4	T. J. Methven	The measurement of ice crystal size in flight. (Unpublished M.o.A. report.)

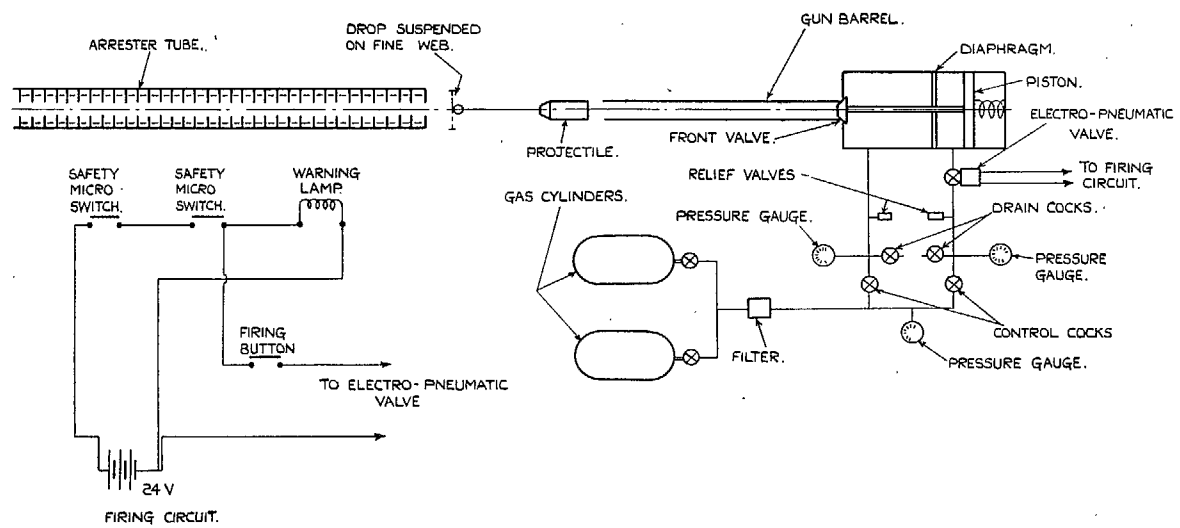

FIG. 1. Diagrammatic arrangement of 1-in. bore apparatus.

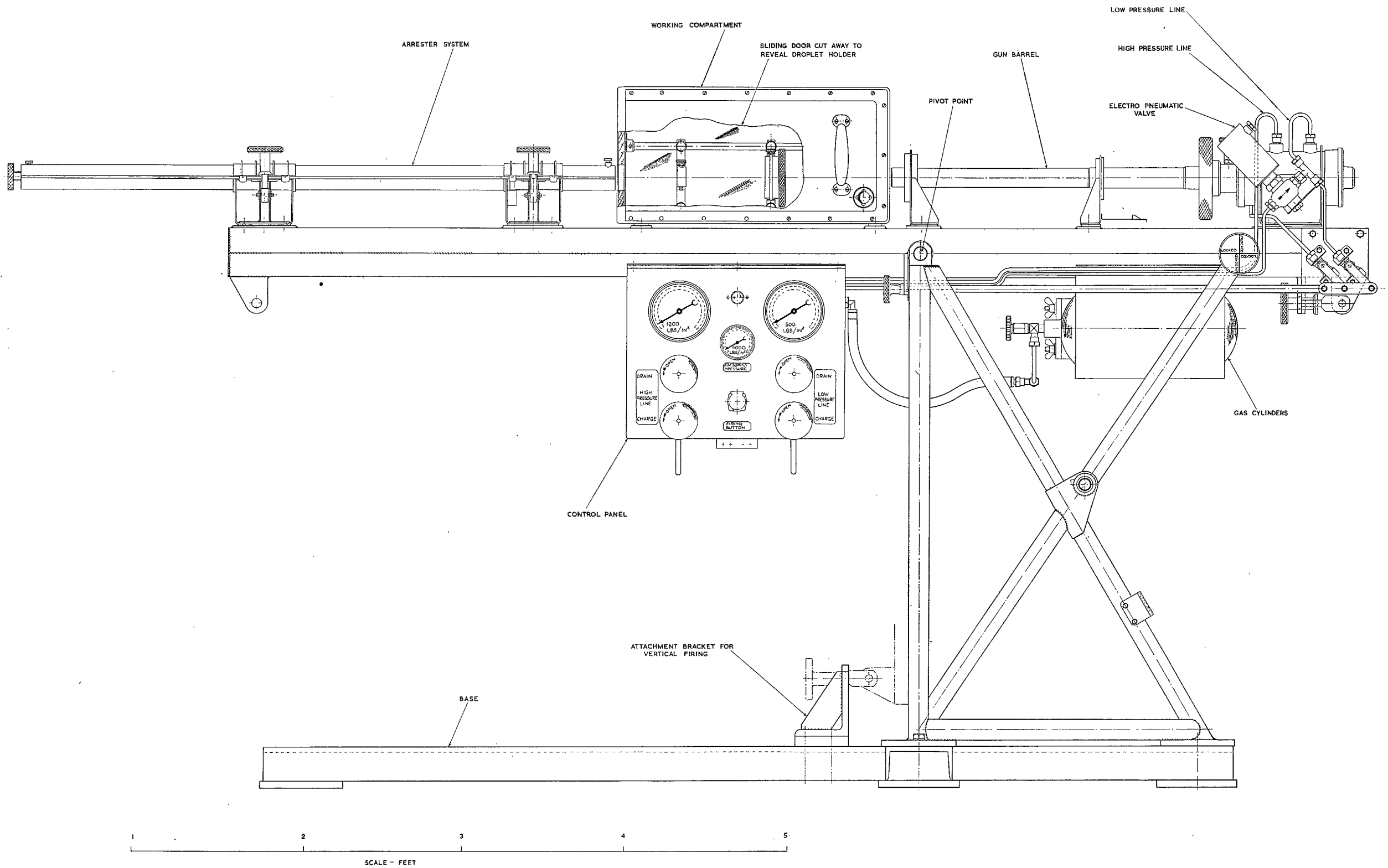

FIG. 2. General arrangement of 1-in. bore apparatus.

11

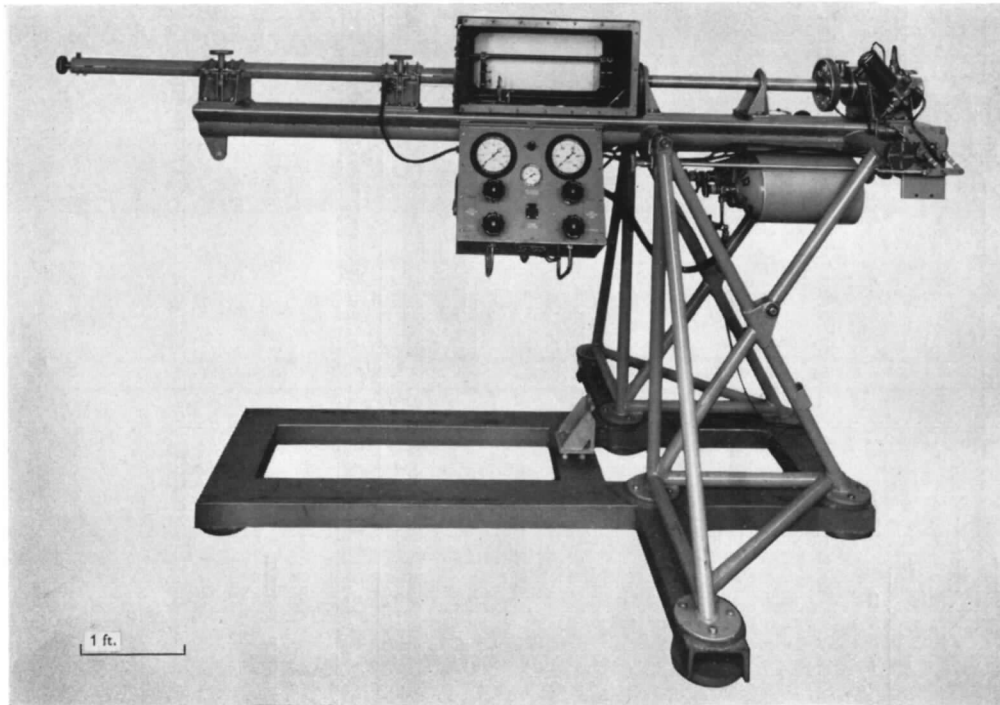

FIG. 3. 1-in. bore apparatus in horizontal firing position.

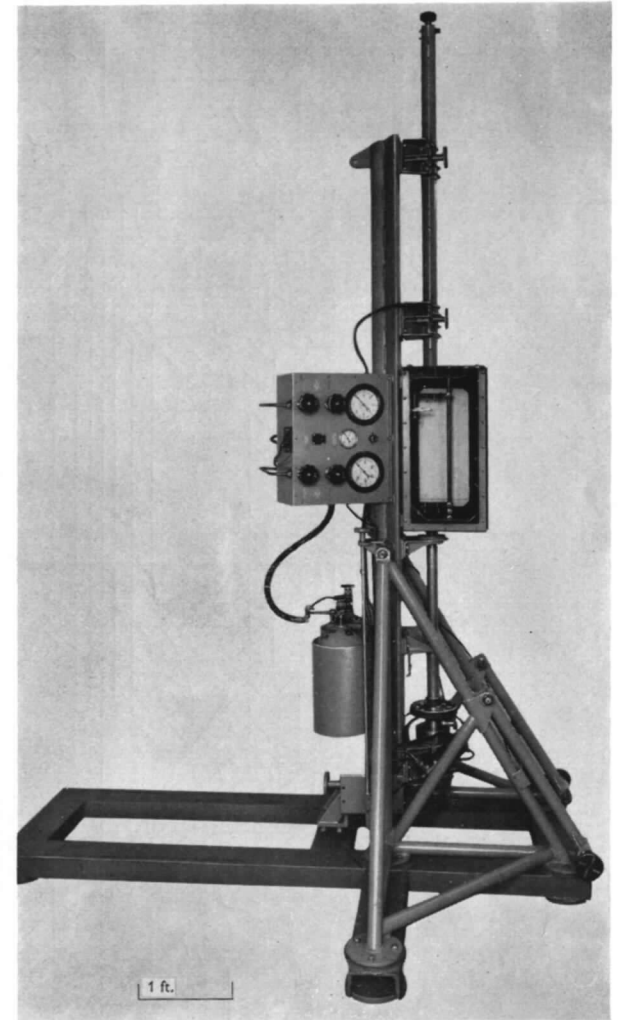

FIG. 4. 1-in. bore apparatus in vertical firing position.

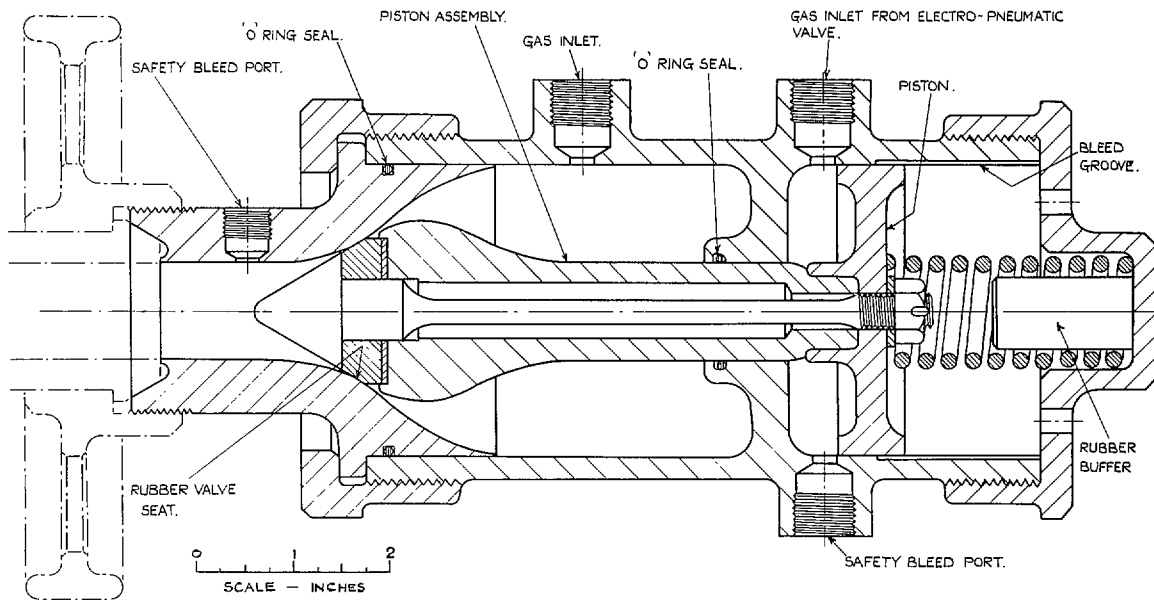
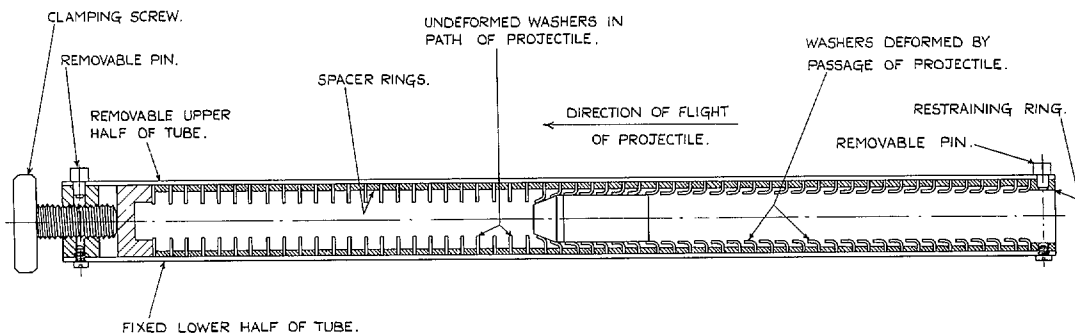

FIG. 5. Section through firing cylinder of 1-in. bore apparatus.



NOT TO SCALE.

FIG. 6. Diagrammatic arrangement of arrester system.

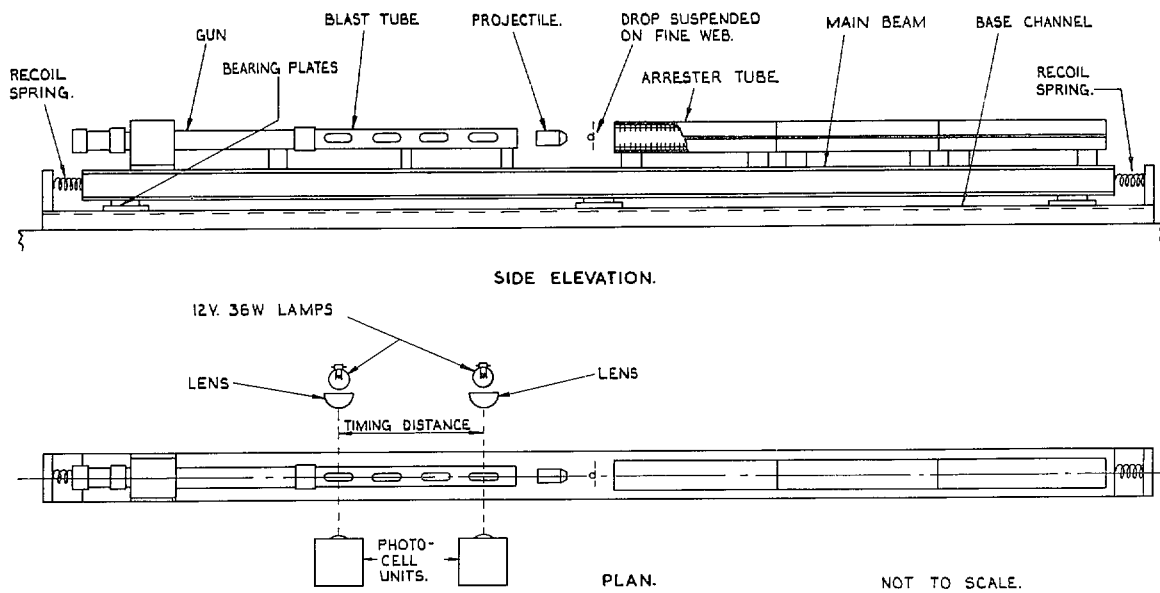

FIG. 7. Diagrammatic arrangement of 1 1/4-in. bore apparatus.

14

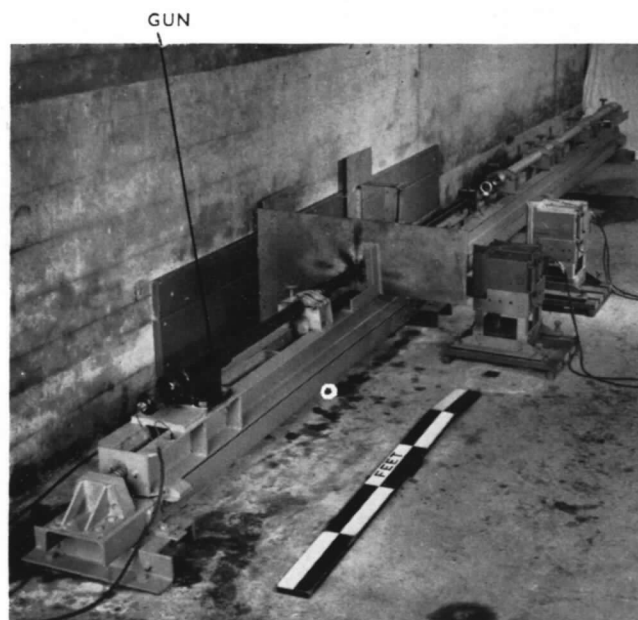

FIG. 8. View from breech end.

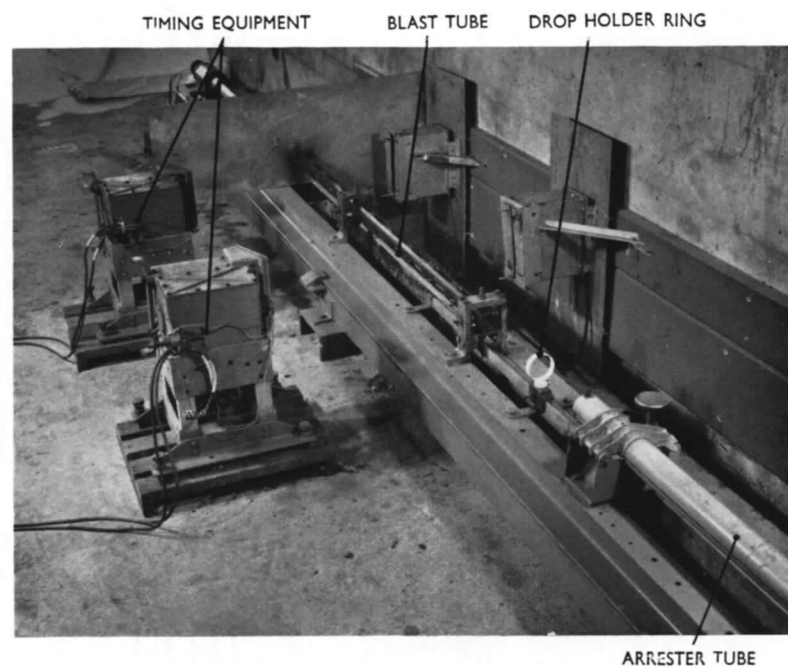

FIG. 9. View showing timing equipment, etc.

FIGS. 8 and 9. 1¼-in. bore apparatus.

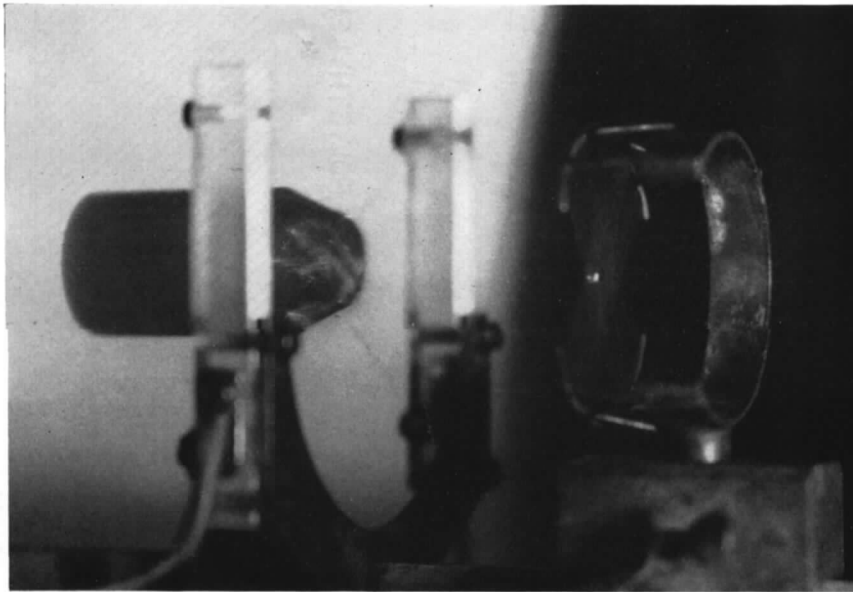

FIG. 10. Projectile about to strike a 2-mm diameter water drop at 1,200 ft/sec.



FIG. 11. Projectile about to strike a 2-mm diameter water drop at 3,000 ft/sec.

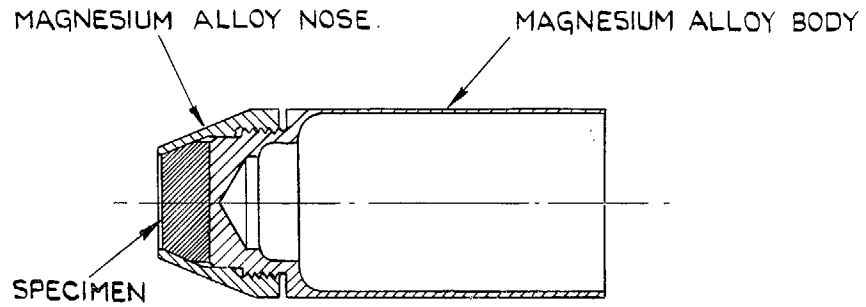

FIG. 12. 1-in. diameter projectile for carrying a thick specimen.

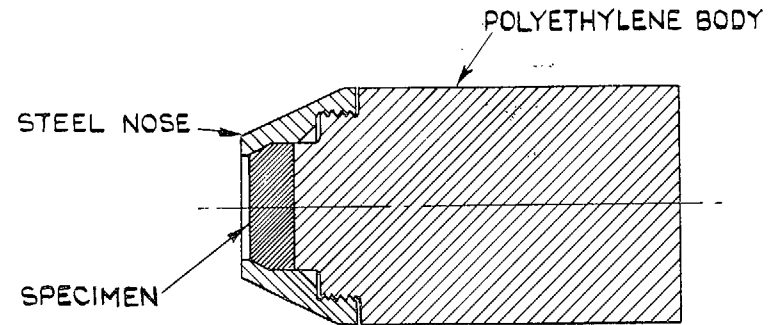

FIG. 14. 1 1/4-in. diameter projectile for carrying a thick specimen.

16

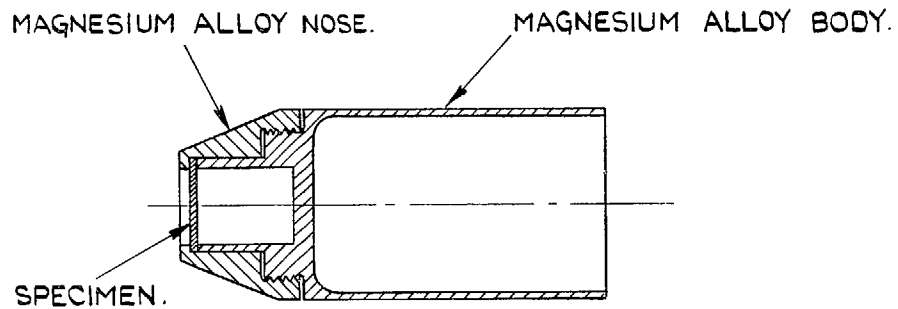

FIG. 13. 1-in. diameter projectile for carrying a sheet specimen.

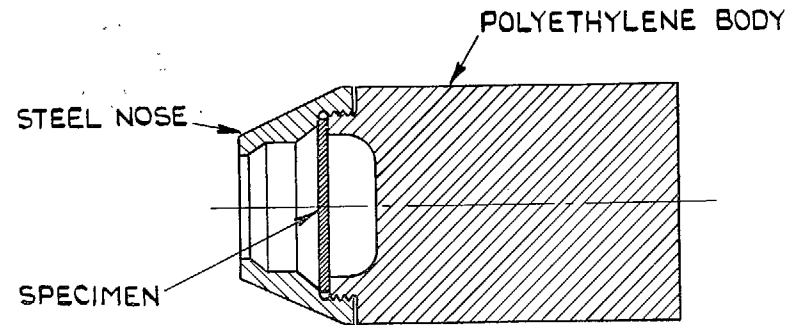

FIG. 15. 1 1/4-in. diameter projectile for carrying a sheet specimen.

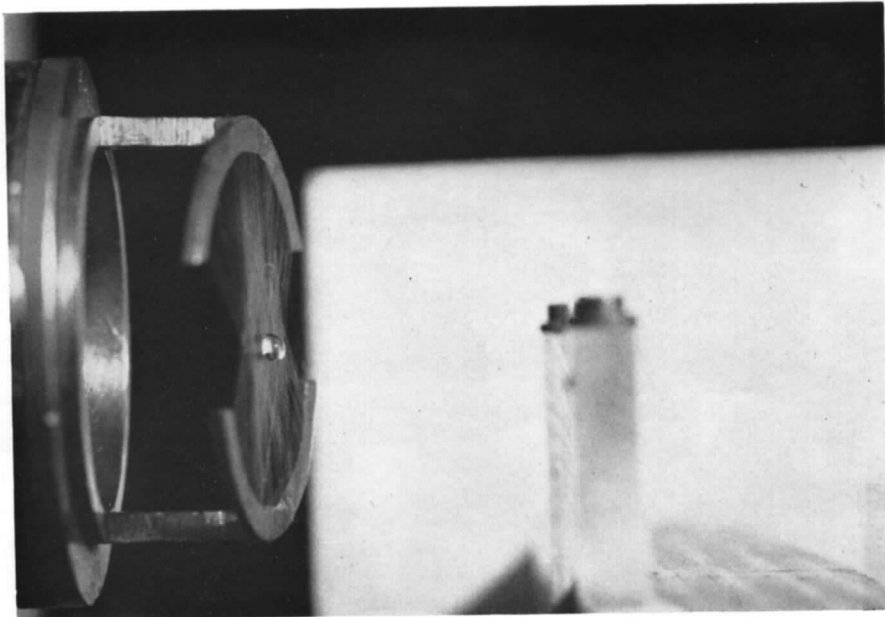

FIG. 16. $2\frac{1}{2}$ -mm diameter water drop suspended on a vertical web.

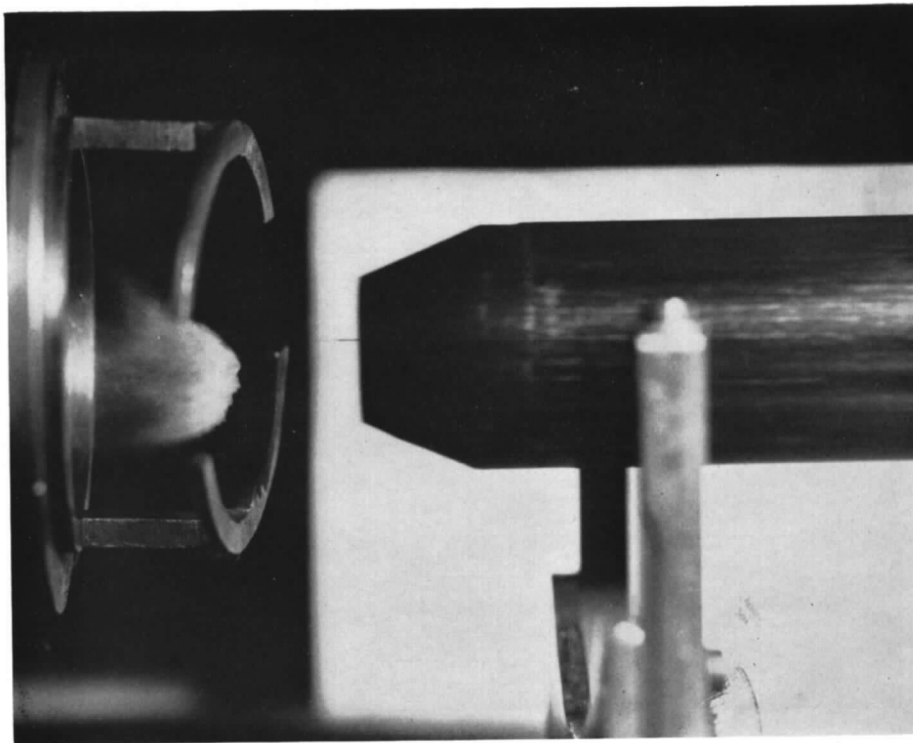

FIG. 17. Projectile about to strike a water drop at 800 ft/sec.

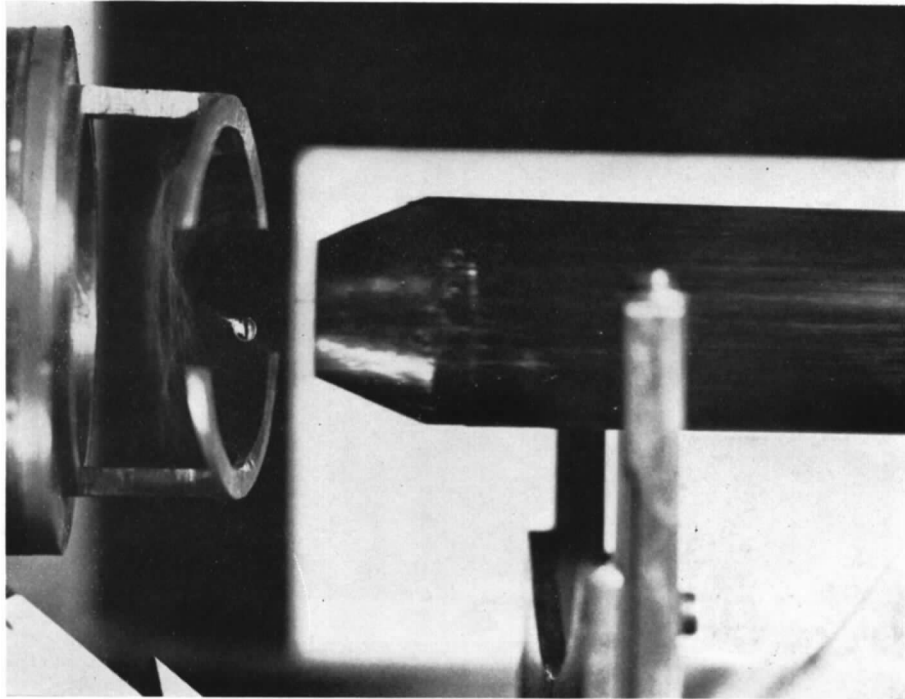

FIG. 18. Shattering of a water drop due to its proximity to the gun muzzle.

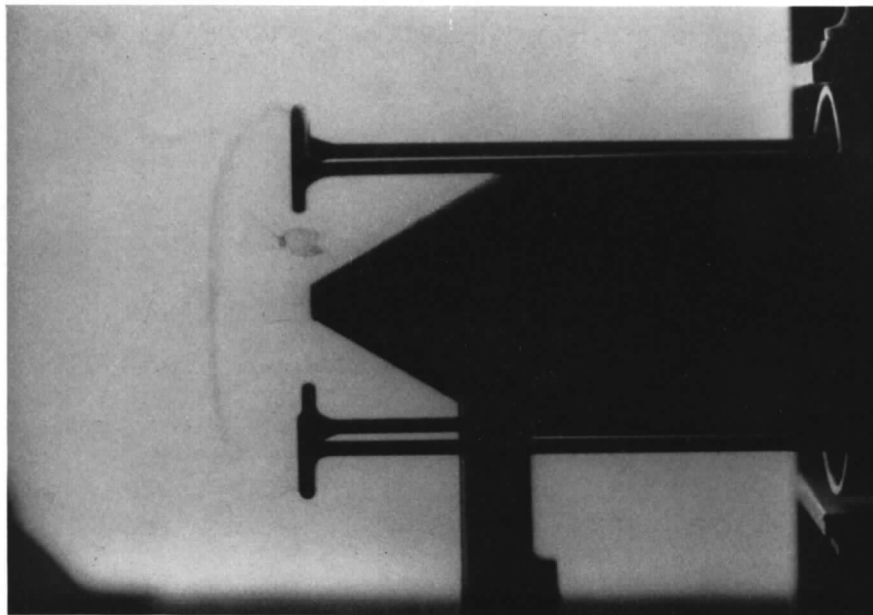

FIG. 19. Break-up of a 2-mm diameter drop in the form of a hollow bag.

WATER DROP TO SAME SCALE



FIG. 20. Mark made on a $\frac{1}{4}$ -in. thick aluminium specimen by a spherical $2\frac{1}{2}$ -mm diameter drop at 800 ft/sec.

WATER DROP TO SAME SCALE

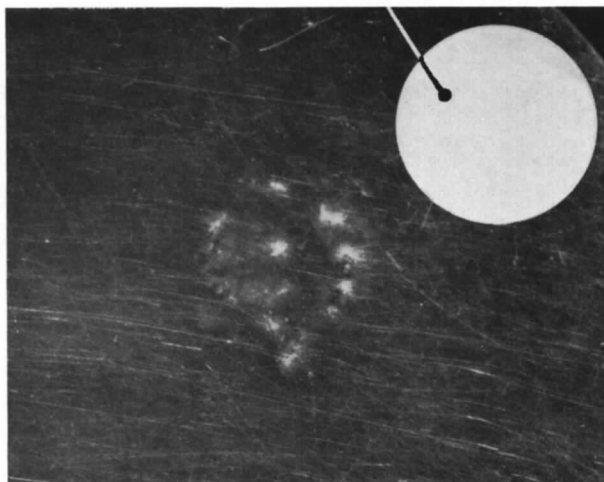

FIG. 21. Mark made on a $\frac{1}{4}$ -in. thick aluminium specimen by a shattered $2\frac{1}{2}$ -mm diameter drop at 800 ft/sec.

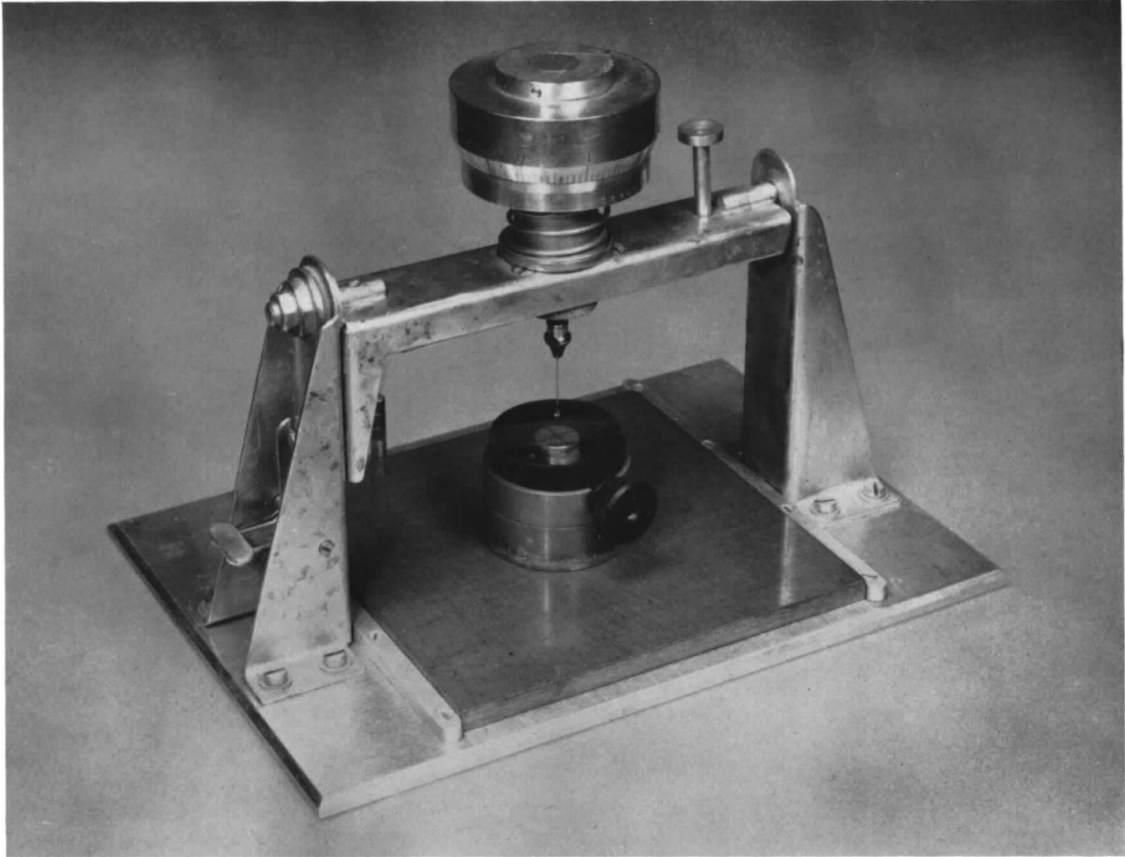
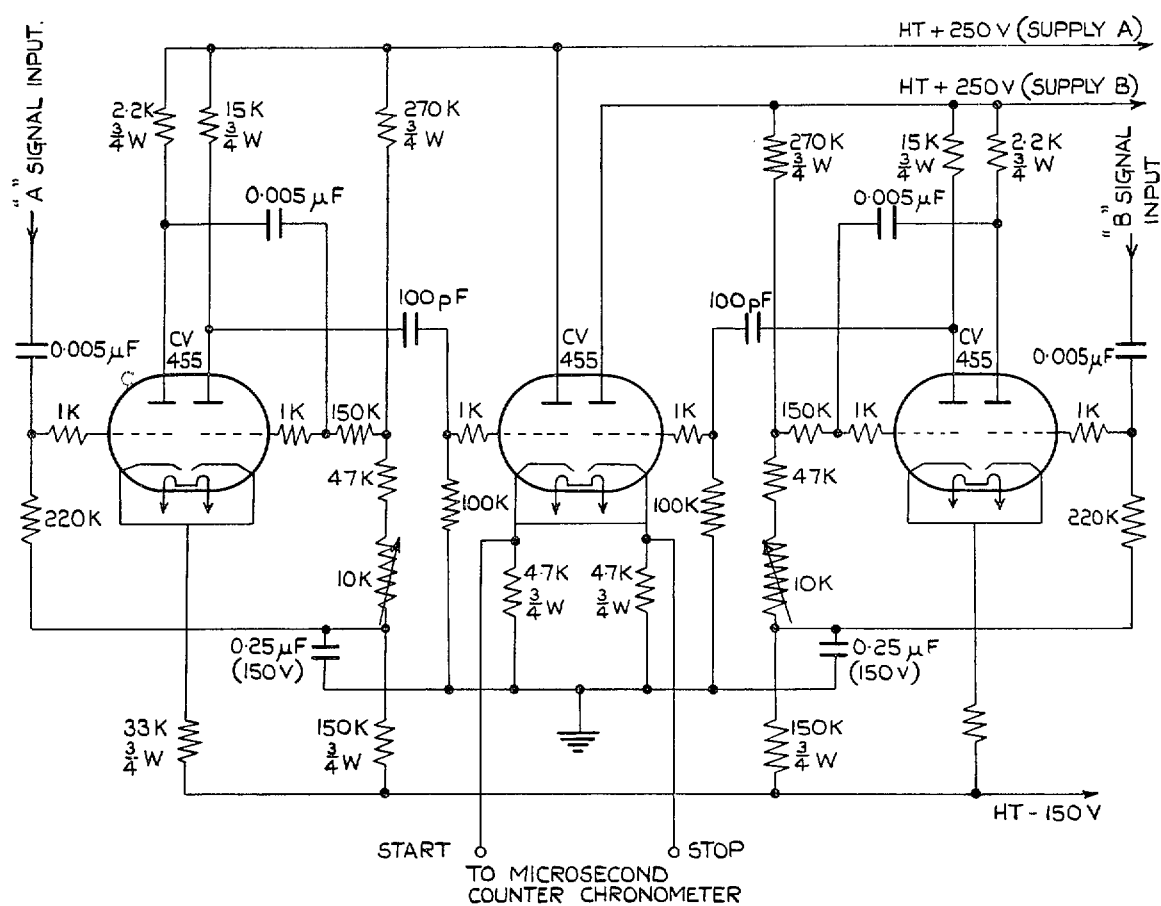
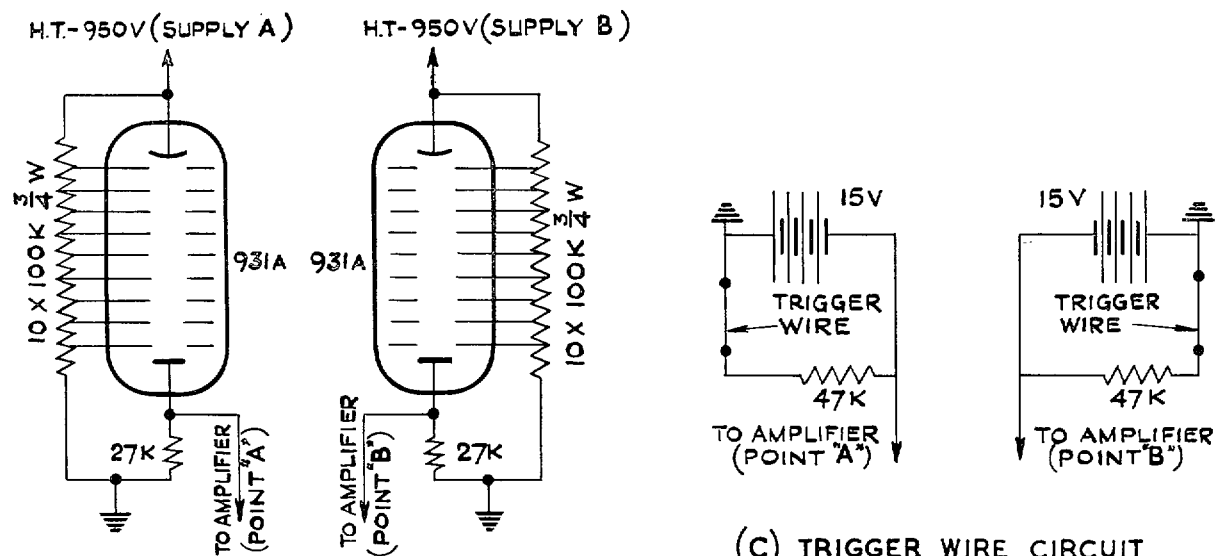

FIG. 22. Micro-burette assembly.



(a) AMPLIFIER CIRCUIT.



(b) PHOTO MULTIPLIER CIRCUIT

(c) TRIGGER WIRE CIRCUIT
 (ALTERNATIVE TO FIG. b)

FIGS. 23a to 23c. Circuit diagram of projectile speed measuring system for 1-in. bore apparatus.

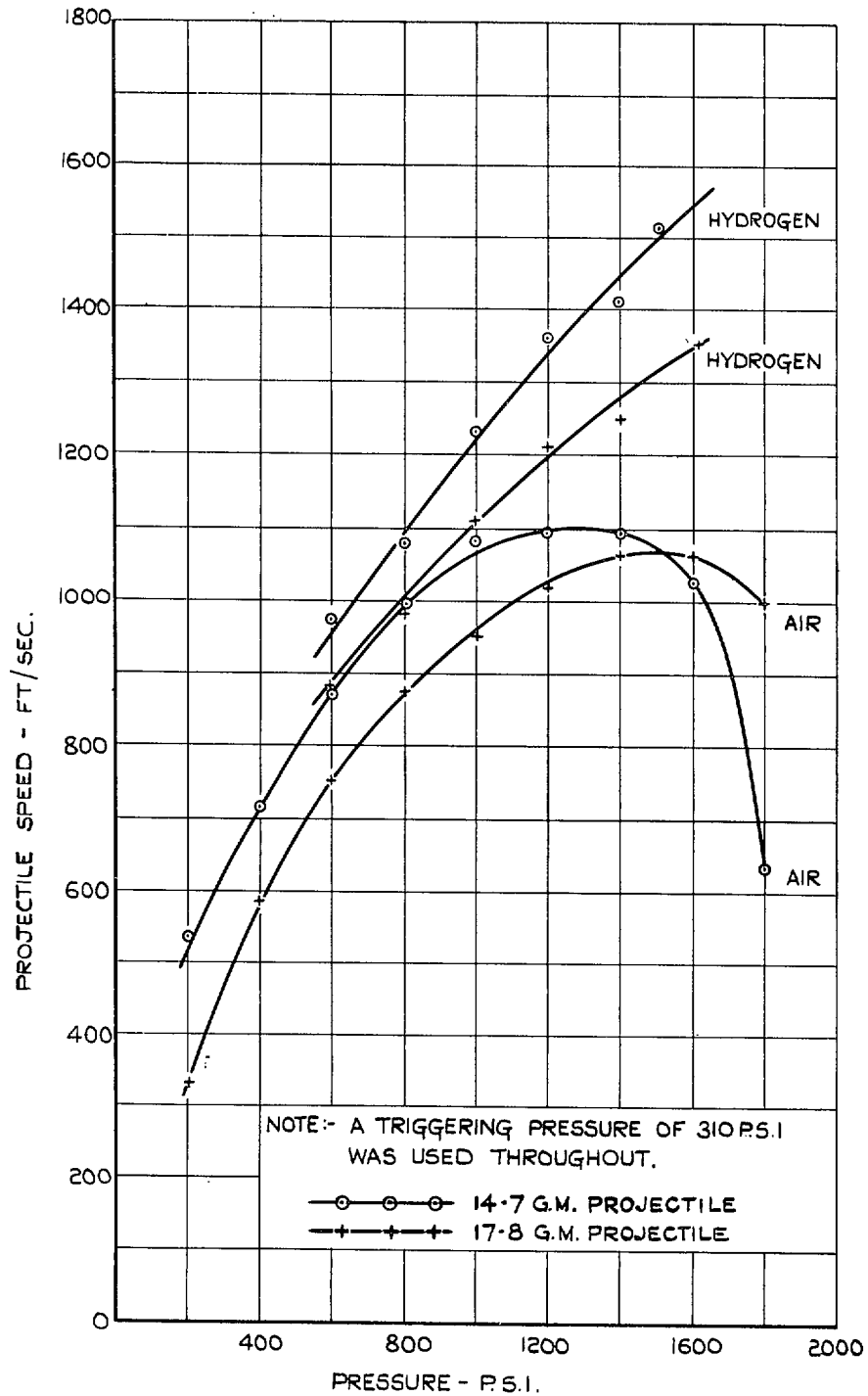

FIG. 24. Gun performance of 1-in. bore apparatus.

WATER DROP TO
SAME SCALE 7

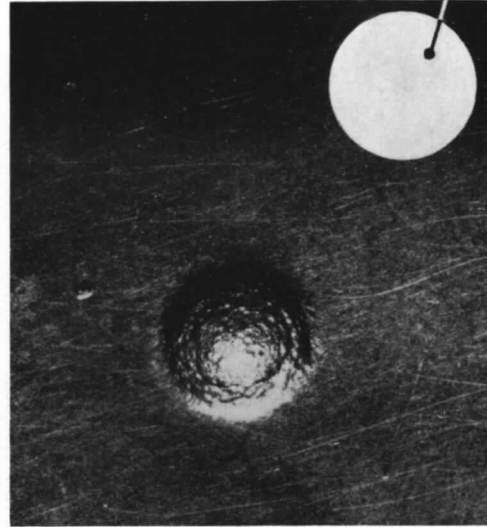

FIG. 25. Mark made on $\frac{1}{4}$ -in. thick aluminium alloy, D.T.D. 423B, by a 2-mm diameter water drop at 3,200 ft/sec.

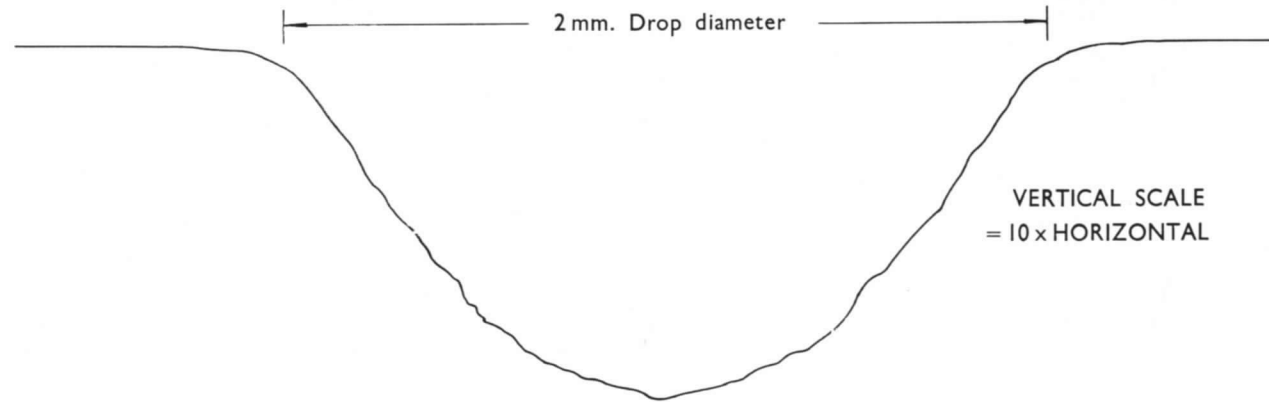

FIG. 26. Cross-section through the mark shown in FIG. 25 as recorded by a Talysurf machine.

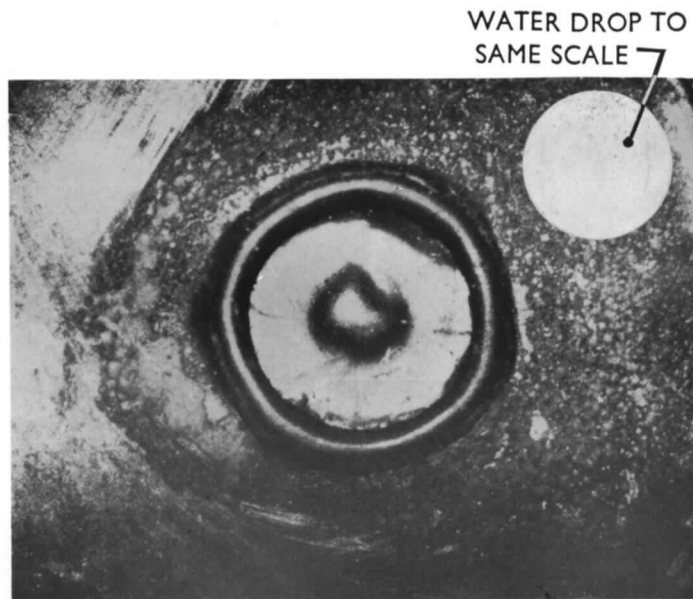

FIG. 27. Mark made in the thin neoprene coating on a specimen by a 2-mm diameter water drop at 2,800 ft/sec.

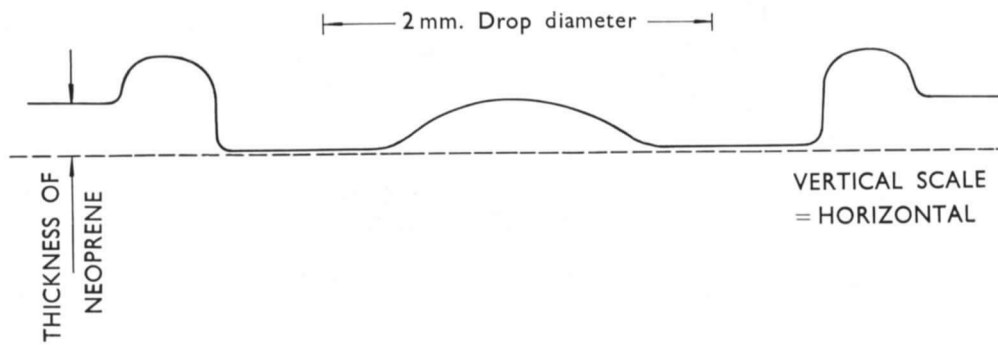

FIG. 28. Approximate cross-section through the mark shown in FIG. 27 as measured by a travelling microscope.

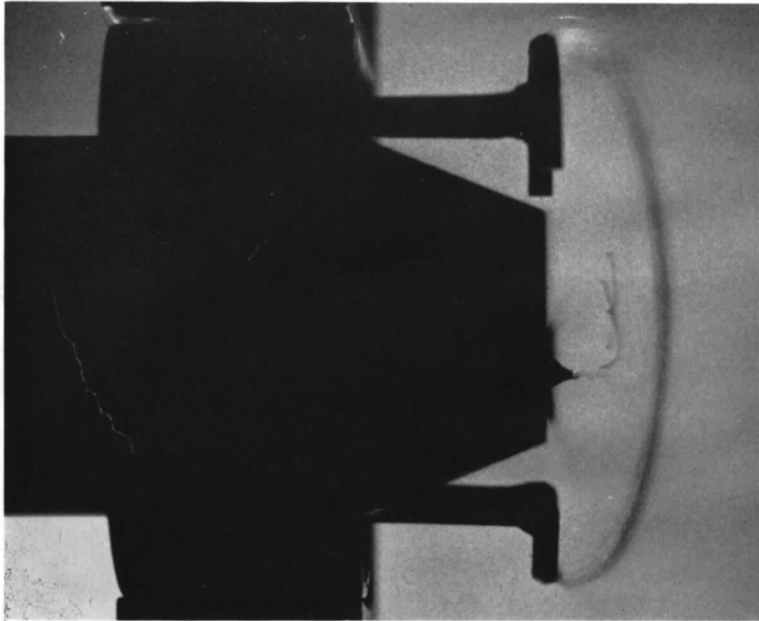

FIG. 29. Normal impact between a 2-mm diameter water drop and a smooth surface moving at 1,000 ft/sec.

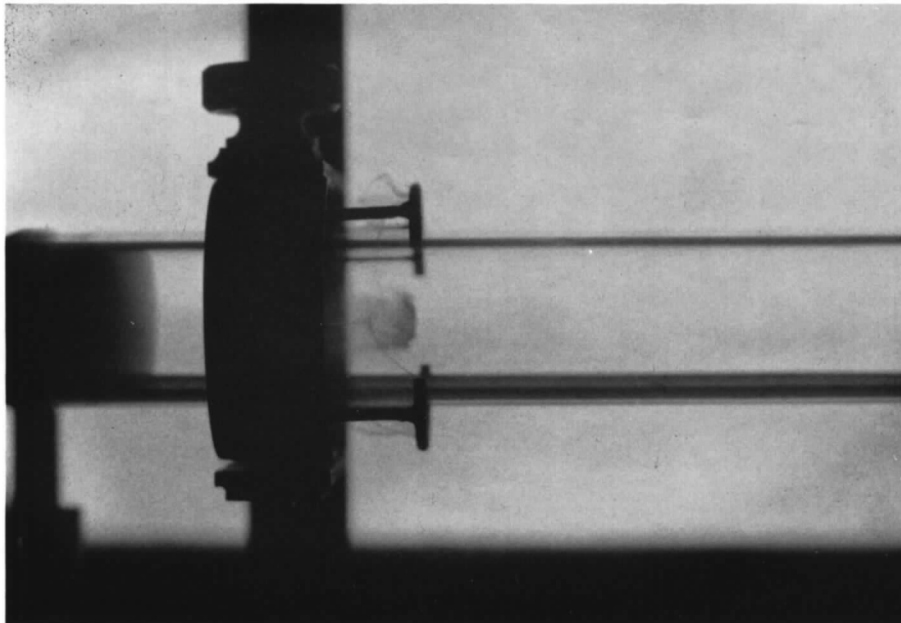

FIG. 30. Break-up of a 2-mm diameter water drop inside a hollow transparent projectile moving at 550 ft/sec.

Publications of the Aeronautical Research Council

ANNUAL TECHNICAL REPORTS OF THE AERONAUTICAL RESEARCH COUNCIL (BOUND VOLUMES)

- 1941 Aero and Hydrodynamics, Aerofoils, Airscrews, Engines, Flutter, Stability and Control, Structures. 63s. (post 2s. 3d.)
- 1942 Vol. I. Aero and Hydrodynamics, Aerofoils, Airscrews, Engines. 75s. (post 2s. 3d.)
Vol. II. Noise, Parachutes, Stability and Control, Structures, Vibration, Wind Tunnels. 47s. 6d. (post 1s. 9d.)
- 1943 Vol. I. Aerodynamics, Aerofoils, Airscrews. 80s. (post 2s.)
Vol. II. Engines, Flutter, Materials, Parachutes, Performance, Stability and Control, Structures. 90s. (post 2s. 3d.)
- 1944 Vol. I. Aero and Hydrodynamics, Aerofoils, Aircraft, Airscrews, Controls. 84s. (post 2s. 6d.)
Vol. II. Flutter and Vibration, Materials, Miscellaneous, Navigation, Parachutes, Performance, Plates and Panels, Stability, Structures, Test Equipment, Wind Tunnels. 84s. (post 2s. 6d.)
- 1945 Vol. I. Aero and Hydrodynamics, Aerofoils. 130s. (post 3s.)
Vol. II. Aircraft, Airscrews, Controls. 130s. (post 3s.)
Vol. III. Flutter and Vibration, Instruments, Miscellaneous, Parachutes, Plates and Panels, Propulsion. 130s. (post 2s. 9d.)
Vol. IV. Stability, Structures, Wind Tunnels, Wind Tunnel Technique. 130s. (post 2s. 9d.)
- 1946 Vol. I. Accidents, Aerodynamics, Aerofoils and Hydrofoils. 168s. (post 3s. 3d.)
Vol. II. Airscrews, Cabin Cooling, Chemical Hazards, Controls, Flames, Flutter, Helicopters, Instruments and Instrumentation, Interference, Jets, Miscellaneous, Parachutes. 168s. (post 2s. 9d.)
Vol. III. Performance, Propulsion, Seaplanes, Stability, Structures, Wind Tunnels. 168s. (post 3s. 6d.)
- 1947 Vol. I. Aerodynamics, Aerofoils, Aircraft. 168s. (post 3s. 3d.)
Vol. II. Airscrews and Rotors, Controls, Flutter, Materials, Miscellaneous, Parachutes, Propulsion, Seaplanes, Stability, Structures, Take-off and Landing. 168s. (post 3s. 3d.)

Special Volumes

- Vol. I. Aero and Hydrodynamics, Aerofoils, Controls, Flutter, Kites, Parachutes, Performance, Propulsion, Stability. 126s. (post 2s. 6d.)
- Vol. II. Aero and Hydrodynamics, Aerofoils, Airscrews, Controls, Flutter, Materials, Miscellaneous, Parachutes, Propulsion, Stability, Structures. 147s. (post 2s. 6d.)
- Vol. III. Aero and Hydrodynamics, Aerofoils, Airscrews, Controls, Flutter, Kites, Miscellaneous, Parachutes, Propulsion, Seaplanes, Stability, Structures, Test Equipment. 189s. (post 3s. 3d.)

Reviews of the Aeronautical Research Council

1939-48 3s. (post 5d.)

1949-54 5s. (post 5d.)

Index to all Reports and Memoranda published in the Annual Technical Reports

1909-47

R. & M. 2600 6s. (post 2d.)

Indexes to the Reports and Memoranda of the Aeronautical Research Council

Between Nos. 2351-2449

R. & M. No. 2450 2s. (post 2d.)

Between Nos. 2451-2549

R. & M. No. 2550 2s. 6d. (post 2d.)

Between Nos. 2551-2649

R. & M. No. 2650 2s. 6d. (post 2d.)

Between Nos. 2651-2749

R. & M. No. 2750 2s. 6d. (post 2d.)

Between Nos. 2751-2849

R. & M. No. 2850 2s. 6d. (post 2d.)

Between Nos. 2851-2949

R. & M. No. 2950 3s. (post 2d.)

Between Nos. 2951-3049

R. & M. No. 3050 3s. 6d. (post 2d.)

HER MAJESTY'S STATIONERY OFFICE

from the addresses overleaf

© *Crown copyright 1961*

Published by
HER MAJESTY'S STATIONERY OFFICE

To be purchased from
York House, Kingsway, London W.C.2
423 Oxford Street, London W.1
13A Castle Street, Edinburgh 2
109 St. Mary Street, Cardiff
39 King Street, Manchester 2
50 Fairfax Street, Bristol 1
2 Edmund Street, Birmingham 3
80 Chichester Street, Belfast 1
or through any bookseller

Printed in England