

ROYAL AIRCRAFT ESTABLISHMENT
BEDFORD.

R. & M. No. 3352



MINISTRY OF AVIATION

AERONAUTICAL RESEARCH COUNCIL
REPORTS AND MEMORANDA

A Note on the Theory of Parachute Stability

By W. G. S. LESTER, M.A., D.Phil.

LONDON: HER MAJESTY'S STATIONERY OFFICE

1964

PRICE 6s. 6d. NET

A Note on the Theory of Parachute Stability

By W. G. S. LESTER, M.A., D.Phil.

COMMUNICATED BY THE DEPUTY CONTROLLER AIRCRAFT (RESEARCH AND DEVELOPMENT),
MINISTRY OF AVIATION

*Reports and Memoranda No. 3352**

July, 1962

Summary.

A re-assessment of a generally accepted theory of parachute stability has been made with the object of clarifying the assumptions used in its derivation and exposing deficiencies in previous treatments. Some new equations are derived but lack of knowledge of the aerodynamic and apparent-mass coefficients prevents a comparison with experiment from being made. The theory is idealised and uncertainties with regard to the relation between the apparent-mass concepts in a real and an ideal fluid suggest that the correlation between theory and experiment may be slight. Experimental work on the apparent mass of a parachute is recommended in order to assess the validity of the theoretical model.

LIST OF CONTENTS

Section

1. Introduction
2. The Parachute Equations of Motion
3. Henn's Equations
4. The Stability Equations
5. Discussion
6. Conclusions

List of References

List of Symbols

Illustrations—Figs. 1 to 3

Detachable Abstract Cards

1. *Introduction.*

In the past parachute stability has been the subject of both theoretical and experimental investigations. A conclusion of a comprehensive American survey of this previous work was that the theoretical analysis given by Henn¹ in 1944 should be suitable for a complete description of

* Replaces R.A.E. Tech. Note No. Mech. Eng. 358—A.R.C. 24,415.

parachute motion provided that the theory of small oscillations could be accepted. Considerable experimental effort has been expended on attempts to validate the various theories, without much success, and recently Henn's equations have been extensively used. The theoretical analysis is difficult to understand and the resulting equations of motion have been widely accepted without apparently considering the principles by which they were derived. In this paper a brief report is given of the results of a re-assessment of the theory from first principles, on the basis of which Henn's equations appear to be erroneous. Some new equations have been derived, but lack of knowledge of the aerodynamic coefficients and the associated air mass coefficients at present preclude the drawing of reliable conclusions, and no comparison has yet been made with experimental results. The theory is idealised and, as such, due regard must be taken of its limitations in any attempt to compare with experiment. Chapter VI of Lamb's Hydrodynamics serves as a general reference for the whole of the present analysis.

2. *The Parachute Equations of Motion.*

The initial assumption made in developing this analysis is that the parachute system, i.e. the canopy, rigging lines and load, behaves as a rigid body moving through an ideal fluid extending to infinity. An ideal fluid will be regarded as one which possesses the properties of being incompressible, inviscid and irrotational; great emphasis should be placed on the assumption that the fluid medium has these properties for this alone enables some progress to be made and at the same time raises problems with regard to the physical validity of the proposed model: these problems will be considered briefly in the discussion.

The rigid-body concept enables a system of axes fixed in the body and moving with it to be adopted. If the axes are rectangular the motion can be defined by the angular velocity components p, q, r about, and the translational velocity components u, v, w of the origin parallel to, the instantaneous positions of the axes.

We assume that the parachute system is rotationally symmetric and take the x -axis *parallel* to the axis of symmetry leaving the origin of the co-ordinate system unspecified. The origin could be specified initially but this is undesirable since it would mask some of the important features of the problem.

The motion of the system under a small disturbance may be an oscillation in one plane containing the axis of symmetry, or a coning in two planes. The conical motion is assumed to be the resultant of oscillations in two mutually perpendicular planes and hence the motion in one plane only need be considered. We take this plane as that of (x, y) and hence

$$p = q = 0; w = 0.$$

Since the fluid is assumed ideal a velocity potential φ can be defined such that

$$\varphi = u\varphi_1 + v\varphi_2 + r\psi_3 \tag{1}$$

where

$$\nabla^2\varphi = \nabla^2\varphi_1 = \nabla^2\varphi_2 = \nabla^2\psi_3 = 0.$$

φ_1, φ_2 and ψ_3 are functions of x, y and z only and are determined entirely by the geometrical configuration of the body relative to the co-ordinate axes. The canopy of the parachute is assumed

to be imporous and so, if l, m denote the direction cosines of the normal in the x, y -plane, drawn towards the fluid at any point of the canopy, then the surface condition of zero normal flow is given by:

$$-\frac{\partial\varphi}{\partial n} = l(u - ry) + m(v + rx)$$

where $\partial/\partial n$ denotes differentiation in the direction of the normal. Hence, on substitution from (1) we have

$$-\frac{\partial\varphi_1}{\partial n} = l; \quad -\frac{\partial\varphi_2}{\partial n} = m; \quad -\frac{\partial\psi_3}{\partial n} = mx - ly. \quad (2)$$

Let T denote the kinetic energy of the whole *fluid* and then

$$2T = -\rho \iint \varphi \frac{\partial\varphi}{\partial n} dS$$

where ρ is the fluid density and the integral is taken over the surface of the body. Substituting the value (1) for φ and using (2)

$$\begin{aligned} 2T = & +\rho \iint [l\varphi_1 u^2 + m\varphi_2 v^2 + (mx - ly)\psi_3 r^2 + \\ & + (l\varphi_2 + m\varphi_1)uv + \{(mx - ly)\varphi_1 + l\psi_3\}ur + \\ & + \{(mx - ly)\varphi_2 + m\psi_3\}vr] dS; \end{aligned}$$

which can be written

$$2T = Au^2 + Bv^2 + Rr^2 + 2Cuv + 2Gur + 2Fvr \quad (3)$$

where

$$A = +\rho \iint l\varphi_1 dS; \quad B = +\rho \iint m\varphi_2 dS;$$

$$R = +\rho \iint (mx - ly)\psi_3 dS, \text{ etc.}$$

The motion of the solid body and of the ideal fluid at any instant might have been generated by means of an impulsive wrench applied to the solid, this wrench being such that it would counteract the impulsive pressure $\rho\varphi$ on the surface and generate the momentum of the solid. Lamb shows that the impulsive wrench, or impulse, varies in consequence of the extraneous forces acting on the solid in the same way as the momentum of a finite dynamical system. If the force components of the wrench are (ξ, η, ζ) and the couple components are (λ, μ, ν) then allowing for the motion of the axes

$$\frac{d}{dt}(\xi, \eta, \zeta) + (p, q, r) \wedge (\xi, \eta, \zeta) = (X, Y, Z) \quad (4)$$

and

$$\frac{d}{dt}(\lambda, \mu, \nu) + (p, q, r) \wedge (\lambda, \mu, \nu) + (u, v, w) \wedge (\xi, \eta, \zeta) = (L, M, N) \quad (5)$$

where (X, Y, Z) and (L, M, N) are the extraneous force and couple components. It can be shown, cf. Lamb, that if the total energy of the whole system, solid and fluid, is

$$\mathcal{E} = T + T_1$$

where T is the kinetic energy of the fluid and T_1 that of the solid, then

$$(\xi, \eta, \zeta) = \left(\frac{\partial \mathcal{F}}{\partial u}, \frac{\partial \mathcal{F}}{\partial v}, \frac{\partial \mathcal{F}}{\partial w} \right) \quad (6)$$

and

$$(\lambda, \mu, \nu) = \left(\frac{\partial \mathcal{F}}{\partial p}, \frac{\partial \mathcal{F}}{\partial q}, \frac{\partial \mathcal{F}}{\partial r} \right) \quad (7)$$

which enable the equations of motion to be written down in terms of the total energy, the velocity components of the axes and the extraneous forces. Thus, in the case we are considering, where

$$p = q = 0; w = 0$$

the general Kirchoff equations of motion for the whole system are

$$\frac{d}{dt} \left(\frac{\partial \mathcal{F}}{\partial u} \right) = r \frac{\partial \mathcal{F}}{\partial v} + X \quad (8)$$

$$\frac{d}{dt} \left(\frac{\partial \mathcal{F}}{\partial v} \right) = -r \frac{\partial \mathcal{F}}{\partial u} + Y \quad (9)$$

and

$$\frac{d}{dt} \left(\frac{\partial \mathcal{F}}{\partial r} \right) = v \frac{\partial \mathcal{F}}{\partial u} - u \frac{\partial \mathcal{F}}{\partial v} + N \quad (10)$$

If we replace \mathcal{F} by $T + T_1$ in (6) and (7) we know from ordinary rigid dynamics that the terms in T_1 represent the linear and angular momentum of the solid and so the remaining terms involving T must give the expressions for the system of impulsive pressures exerted by the surface of the solid on the fluid. On isolating the terms in T from the Kirchoff equations (8), (9) and (10) we obtain equations for the forces exerted on the solid by the pressure of the surrounding fluid. In the case of a pure translation of the parachute system with a constant velocity $(u, v, 0)$ the couple exerted on the system by the pressure of the fluid is

$$v \frac{\partial T}{\partial u} - u \frac{\partial T}{\partial v}$$

which vanishes if $\partial T / \partial u : u = \partial T / \partial v : v$, i.e. provided the velocity $(u, v, 0)$ is in the direction of one of the principal axes of the ellipse

$$Ax^2 + By^2 + 2Cxy = \text{constant.}$$

It is now apparent that a choice of axes can be made such that if the parachute system is set in motion parallel to one of these axes, without rotation, and left to itself, it continues to move in this manner and there is no resultant moment on the system. For the rotationally symmetric system it is physically evident that the axes must be given by the axis of symmetry and any two mutually perpendicular directions: hence the so-called principal directions of a system are defined.

In the present problem we commenced by taking the x -axis parallel to the axis of symmetry and hence the couple

$$v \frac{\partial T}{\partial u} - u \frac{\partial T}{\partial v}$$

must be zero for a translation in the direction of this axis and any axis at right angles to it. Thus,

$$v \frac{\partial T}{\partial u} - u \frac{\partial T}{\partial v} = (A - B)uv - C(u^2 - v^2)$$

must be zero when $u = \bar{U}, v = 0$ and also when $u = 0, v = \bar{V}$. Hence C is zero.

Therefore

$$2T = Au^2 + Bv^2 + Rr^2 + 2Gur + 2Fvr.$$

Without losing generality we can now take the x -axis as the actual axis of symmetry of the parachute. The kinetic energy of the fluid must remain unchanged if the signs of v and r are reversed. A reversal of these signs is equivalent to rotating the y and z axes about Ox through π radians as in Figs. 1a and b. Fig. 1a represents the system before the rotation of the axes and Fig. 1b the system after the rotation. Due to the rotational symmetry the flow pattern after rotation must be unchanged and hence the kinetic energy of the fluid is also unchanged. Hence $G = 0$ and

$$2T = Au^2 + Bv^2 + Rr^2 + 2Fvr. \quad (11)$$

A reversal of the signs of u and r is equivalent to rotating the x and z axes about Oy through π radians which, in general, results in a different flow pattern with a different kinetic energy. The flow pattern can only be the same if the parachute system possesses fore and aft symmetry. Thus we must normally regard F as being non-zero.

Let us take some arbitrary position O' on the x -axis for the origin of co-ordinates and suppose that the origin is transferred to some point $(s, 0)$. In the energy equation we must simply replace 'v' by $v - rs$ and

$$2T = Au^2 + Bv^2 + 2(F - Bs)vr + (Bs^2 - 2Fs + R)r^2. \quad (12)$$

If we had chosen $s = F/B$ then

$$2T = Au^2 + Bv^2 + \left(R - \frac{F^2}{B}\right)r^2 \quad (13)$$

and the position of the origin and orientation of the axes would have been completely specified. But both F and B may be difficult to determine and it is best to regard equation (12) as giving the kinetic energy of the fluid. Referring to equation (12), u and v are now the component velocities of the origin of co-ordinates and r is the angular velocity; A , B , R and F are certain functions determined solely by the geometrical configuration of the body referred to parallel axes removed a distance s in the direction of the axis of symmetry from the origin of co-ordinates.

Let us assume that the mass of the parachute canopy and rigging lines is m and its centre of gravity lies on the axis of symmetry at a point G distance h from the origin O . In Fig. 2 the velocity components of O are (u, v) and A , B , F and R are calculated relative to O' where $OO' = s$. The mass of the load is assumed to be concentrated at O into a point mass M and in consequence has no moment of inertia. The total kinetic energy of the parachute system is thus given by T_1 where

$$2T_1 = (m + M)(u^2 + v^2) - 2mhvr + (I + mh^2)r^2 \quad (14)$$

where I is the moment of inertia of the canopy about an axis through G perpendicular to the x, y -plane. The total kinetic energy of the parachute system and the fluid is \mathcal{T} and

$$\begin{aligned} 2\mathcal{T} = 2(T + T_1) = & (M + m + A)u^2 + (M + m + B)v^2 + \\ & + (I + mh^2 + Bs^2 - 2Fs + R)r^2 + \\ & + 2(F - Bs - mh)vr. \end{aligned} \quad (15)$$

Substituting from equation (15) into the Kirchoff equations (8), (9) and (10) we obtain the general equations of motion of the parachute

$$(M+m+A)\dot{u} - (M+m+B)vr - (F-Bs-mh)r^2 = X \quad (16)$$

$$(M+m+B)\dot{v} + (F-Bs-mh)\dot{r} + (M+m+A)ur = Y \quad (17)$$

$$(I+mh^2+B_s^2-2Fs+R)\dot{r} + (F-Bs-mh)\dot{v} - (A-B)uv + (F-Bs-mh)ur = N. \quad (18)$$

These equations are exact and involve no assumptions other than that the fluid is ideal and infinite, the parachute canopy is imporous and rotationally symmetric, the load is a point mass and motion in only one plane of symmetry need be considered.

In order to make use of equations (16) to (18) it is necessary to make further assumptions. The mass of the canopy and rigging lines is generally only about 10% of the mass of the load and in comparison can be neglected. If the functions A , B , R and F are calculated relative to the centre of gravity of the parachute canopy $s = h$. It is assumed, although this is not necessary for the subsequent analysis, that m is small compared with B and the moment of inertia of the canopy I is small compared with the apparent moment of inertia R . The equations (16), (17) and (18) can therefore be written

$$(M+A)\dot{u} - (M+B)vr - (F-Bs)r^2 = X \quad (19)$$

$$(M+B)\dot{v} + (F-Bs)\dot{r} + (M+A)ur = Y \quad (20)$$

$$(R+B_s^2-2Fs)\dot{r} + (F-Bs)\dot{v} - (A-B)uv + (F-Bs)ur = N. \quad (21)$$

3. Henn's Equations.

In Henn's derivation of the equations of motion it is assumed that the canopy can be replaced by an air-filled ellipsoid. This possesses fore and aft symmetry and so F is zero. In the present notation the equations given by Henn are:

$$(M+A)\dot{u} - (M+B)vr + Bs^2 = X \quad (22)$$

$$(M+B)\dot{v} - Bs\dot{r} + (M+A)ur = Y \quad (23)$$

$$(R+B_s^2)\dot{r} - Bs\dot{v} - Asur = N. \quad (24)$$

With $F = 0$ in equations (19) to (21) the equations (19) and (22) are identical and so are (20) and (23); but equation (21) differs from equation (24) and is

$$(R+B_s^2)\dot{r} - Bs\dot{v} - (A-B)uv - Bsuv = N. \quad (25)$$

Equation (25) was derived by means of the Kirchoff equation (10); this equation for the combined motion of body and fluid was not used by Henn, instead he reverted to the methods of rigid dynamics and took the moment of the rate of change of momentum about the load point and equated it to the external force moment in the form

$$R\dot{r} - sY' = N. \quad (26)$$

where

$$Y' = B\dot{v} - Bs\dot{r} + Aur$$

is the force in the y -direction at the centre of gravity of the canopy. This leads to equation (24). Whilst this may seem plausible a closer investigation shows that the approach is ambiguous. Let us

suppose that the rigid dynamical equations, as opposed to the Kirchoff equations, may be used provided that the effects of the apparent masses A and B and the apparent moment of inertia R are taken into account. Neglecting the canopy mass the components of linear momentum for the canopy can be written

$$p_x = Au$$

$$p_y = B(v - sr);$$

and the angular momentum about O is

$$h_z = Rr - B(v - sr)s.$$

In terms of moving axes the general rigid dynamical equations of motion are

$$\dot{p}_x - p_y \dot{r} = X' \tag{27}$$

$$\dot{p}_y + p_x \dot{r} = Y' \tag{28}$$

and

$$\dot{h}_z + p_y u - p_x v = N'. \tag{29}$$

Thus, for the canopy:

$$A\dot{u} - Bvr + Bsr^2 = X' - X''$$

$$B\dot{v} + Bs\dot{r} + Aur = Y' - Y''$$

$$(R + Bs^2)\dot{r} - Bs\dot{v} - (A - B)uv - Bsur = N'$$

and similarly for the load:

$$M\dot{u} - Mvr = X_1 - X''$$

$$M\dot{v} + Mur = Y_1 - Y''$$

$$0 = N - N'$$

where the double dashes refer to internal forces between the canopy and load. By addition we have

$$(M + A)\dot{u} - (M + B)vr + Bsr^2 = X_1 + X' = X$$

$$(M + B)\dot{v} - Bs\dot{r} + (M + A)ur = Y_1 + Y' = Y$$

$$(R + Bs^2)\dot{r} - Bs\dot{v} - (A - B)uv - Bsur = N$$

and these three equations are in complete agreement with the Kirchoff equations from (19), (20) and (21). It is apparent that equations (26) and (29) are not equivalent and that the discrepancy stems from the use of the apparent masses A and B —if and only if $A = B$ then an equivalence results and in general this is not so. Any attempt to treat the problem on a rigid-dynamical basis is unsatisfactory for one is effectively trying to treat mass as a vectorial quantity.

A similar error to that made by Henn has been made by Brown² and appears to have been commonly reproduced in several series of lectures. If the classical hydrodynamic analysis is used it is imperative to realise that the Kirchoff equations for the combined motion of body and fluid are the fundamental equations. Under certain circumstances the equations of rigid dynamics, including apparent masses, can lead to a correct result, in general they will not; their use merely obscures the importance of such factors as the reasons for the choice of axes and the significance of the apparent-mass coefficients. Only by reverting to the fundamental equations and starting almost from first principles can the salient features of the problem be exposed.

Let us return to equations (19), (20) and (21): in general F is non-zero and the functions A , B , F and R are calculated relative to the centre of gravity of the canopy. Physically the flow past a parachute canopy differs greatly from a potential flow; the flow separates at the canopy edge and a large turbulent wake is formed outside which the flow can reasonably be approximated by a potential flow. It is not very convincing to regard the canopy and wake as being represented by an air-filled ellipsoid as in Henn's analysis and it is of some interest to consider the stability of the motion given by equations (19) to (21).

4. The Stability Equations.

The basic analysis given in this section should be applicable to any solid of revolution moving in an ideal fluid and subject to certain extraneous forces. We consider the slightly disturbed steady descent of a parachute. The parachute is initially assumed to be descending vertically, i.e. at zero angle of attack, with a constant velocity V_0 , in the direction of its axis of rotational symmetry. The load mass is M and the inflated-canopy radius K .

Suppose that the velocity vector is directed at δ to the vertical and the parachute axis makes an angle γ with the vertical as in Fig. 3.

The extraneous forces consist of the components of the load and the air drag and moment:

$$X = Mg \cos \gamma - \frac{1}{2} \rho C_D \pi K^2 V^2 \cos \eta + \frac{1}{2} \rho C_L \pi K^2 V^2 \sin \eta \quad (30)$$

$$Y = -Mg \sin \gamma + \frac{1}{2} \rho C_D \pi K^2 V^2 \sin \eta + \frac{1}{2} \rho C_L \pi K^2 V^2 \cos \eta \quad (31)$$

$$N = \frac{1}{2} \rho C_N \pi K^3 V^2 \quad (32)$$

where the drag D in the direction of the velocity vector V is given by

$$D = \frac{1}{2} \rho C_D \pi K^2 V^2 \quad (33)$$

and the lift L by

$$L = \frac{1}{2} \rho C_L \pi K^2 V^2. \quad (34)$$

It is supposed that the system is slightly disturbed; V is initially constant and equal to V_0 in the vertical direction, also $\delta = \eta = 0$ and $r = 0$; we assume δ , η , $\dot{\delta}$, $\dot{\eta}$, $\ddot{\delta}$, $\ddot{\eta}$, r and \dot{r} are all small so that their squares and products may be neglected; on being disturbed

$$V \rightarrow V_0 + \Delta V$$

$$r \rightarrow \dot{\delta} + \dot{\eta}$$

and the resultant velocity is in a direction making an angle η with the x -axis. Thus

$$u = (V_0 + \Delta V) \cos \eta$$

$$v = -(V_0 + \Delta V) \sin \eta$$

$$\dot{u} = \Delta \dot{V} \cos \eta - (V_0 + \Delta V) \sin \eta \cdot \dot{\eta}$$

$$\dot{v} = -\Delta \dot{V} \sin \eta - (V_0 + \Delta V) \cos \eta \cdot \dot{\eta}$$

and when η is small

$$u \sim V_0 + \Delta V$$

$$v \sim -V_0 \eta$$

$$\dot{u} \sim \Delta \dot{V}$$

$$\dot{v} \sim -V_0 \dot{\eta}$$

Initially in the steady vertical descent

$$Mg = \frac{1}{2} \rho C_D \pi K^2 V_0^2.$$

We assume that the drag coefficient C_D is an even function of η and r , and that the lift coefficient C_L and moment coefficient C_N are both odd functions.

Hence to first order:

$$\frac{\partial C_D}{\partial \eta} = 0 = \frac{\partial C_D}{\partial r} \quad (35)$$

$$C_L = \frac{\partial C_L}{\partial \eta} \cdot \eta + \frac{\partial C_L}{\partial r} \cdot r; \quad C_N = \frac{\partial C_N}{\partial \eta} \cdot \eta + \frac{\partial C_N}{\partial r} \cdot r. \quad (36)$$

On substituting into the equations of motion (19), (20) and (21) and retaining only first-order terms we obtain

$$(M+A)\Delta\dot{V} = -\rho C_D \pi K^2 V_0 \Delta V \quad (37)$$

$$\begin{aligned} (M+A)V_0\dot{\delta} + (A-B)V_0\dot{\eta} + (F-Bs)(\ddot{\delta} + \ddot{\eta}) \\ = \left\{ \frac{\partial C_L}{\partial \eta} \cdot \eta + \frac{\partial C_L}{\partial \left(\frac{rK}{V_0}\right)} (\delta + \eta) \frac{K}{V_0} - C_D \delta \right\} \frac{1}{2} \rho \pi K^2 V_0^2 \end{aligned} \quad (38)$$

$$\begin{aligned} (R+B_s^2-2Fs)(\ddot{\delta} + \ddot{\eta}) + (F-Bs)V_0\dot{\delta} + (A-B)V_0\dot{\eta} \\ = \left\{ \frac{\partial C_N}{\partial \eta} \cdot \eta + \frac{\partial C_N}{\partial \left(\frac{rK}{V_0}\right)} (\delta + \eta) \frac{K}{V_0} \right\} \frac{1}{2} \rho \pi K^3 V_0^2. \end{aligned} \quad (39)$$

Equation (37) contains ΔV only and has the solution

$$\Delta V = \alpha \exp \left(-\frac{\rho C_D \pi K^2 V_0}{M+A} \cdot t \right)$$

where α is a constant. This shows that the velocity disturbance fades rapidly with time. The motion given by equations (38) and (39) is of more importance since these equations determine the lateral motion. It is most convenient to study them in a non-dimensional form and to non-dimensionalise we introduce the following quantities:

(a) $t = \frac{2M}{\rho \pi K^2 V_0} \tau$, a time scale;

(b) the ratio $\frac{s}{K}$ of the distance of the load from the centre of gravity of the canopy to the parachute radius;

(c) $\frac{i^2}{K^2}$ where $i^2 = \frac{R}{B}$;

(d) the mass ratios $m_x = \frac{A}{M}$, $m_y = \frac{B}{M}$;

(e) the function $\frac{F}{MK}$ and

(f) the mass-effect number $\mathcal{M} = \frac{2M}{\rho \pi K^3}$.

Differentiation with respect to τ is, for convenience, still denoted by means of the Newtonian dot. Non-dimensionalising equations (38) and (39) the following results are obtained:

$$\left\{ \frac{F}{MK} - m_y \left(\frac{s}{K} \right) \right\} (\ddot{\delta} + \ddot{\eta}) - \left\{ \frac{\partial C_L}{\partial \left(\frac{rK}{V_0} \right)} - (m_x - m_y) \mathcal{M} \right\} (\dot{\delta} + \dot{\eta}) - \frac{\partial C_L}{\partial \eta} \cdot \mathcal{M} (\delta + \eta) + (1 + m_y) \mathcal{M} \dot{\delta} + \left(C_D + \frac{\partial C_L}{\partial \eta} \right) \mathcal{M} \delta = 0 \quad (40)$$

$$\left\{ \left(\frac{i^2}{K^2} + \frac{s^2}{K^2} \right) m_y - 2 \left(\frac{F}{MK} \right) \frac{s}{K} \right\} (\ddot{\delta} + \ddot{\eta}) - \frac{\partial C_N}{\partial \left(\frac{rK}{V_0} \right)} (\dot{\delta} + \dot{\eta}) + \left\{ (m_x - m_y) \mathcal{M}^2 - \frac{\partial C_N}{\partial \eta} \cdot \mathcal{M} \right\} (\delta + \eta) + \left\{ \frac{F}{MK} - m_y \left(\frac{s}{K} \right) \right\} \mathcal{M} \dot{\delta} - \left\{ (m_x - m_y) \mathcal{M}^2 - \frac{\partial C_N}{\partial \eta} \cdot \mathcal{M} \right\} \delta = 0. \quad (41)$$

These equations (40) and (41) can be written in the form

$$P_i(\ddot{\delta} + \ddot{\eta}) + Q_i(\dot{\delta} + \dot{\eta}) + R_i(\delta + \eta) + S_i\dot{\delta} + T_i\delta = 0$$

$i = 1, 2$

and have solutions of the form

$$\delta = \sum_j a_j \exp(x_j \tau) \text{ and } \eta = \sum_j b_j \exp(x_j \tau).$$

Then

$$(a_j + b_j)(P_1 x_j^2 + Q_1 x_j + R_1) + a_j(S_1 x_j + T_1) = 0$$

$$(a_j + b_j)(P_2 x_j^2 + Q_2 x_j + R_2) + a_j(S_2 x_j + T_2) = 0$$

and eliminating a_j and b_j we obtain a cubic equation for the time factors x_j :

$$(P_1 x^2 + Q_1 x + R_1)(S_2 x + T_2) - (P_2 x^2 + Q_2 x + R_2)(S_1 x + T_1) = 0$$

and this frequency equation can be written

$$\alpha_3 x^3 + \alpha_2 x^2 + \alpha_1 x + \alpha_0 = 0 \quad (42)$$

where the coefficients have the following values:

$$\alpha_3 = \left(\frac{F}{MK} \right)^2 + 2 \left(\frac{F}{MK} \right) \frac{s}{K} - m_y \left\{ (1 + m_y) \frac{i^2}{K^2} + \frac{s^2}{K^2} \right\} \quad (43)$$

$$\alpha_2 = \left\{ \frac{F}{MK} - m_y \frac{s}{K} \right\} \left\{ \frac{\partial C_N}{\partial \eta} - \frac{\partial C_L}{\partial \left(\frac{rK}{V_0} \right)} \right\} + (1 + m_y) \frac{\partial C_N}{\partial \left(\frac{rK}{V_0} \right)} - \left\{ C_D + \frac{\partial C_L}{\partial \eta} \right\} \left\{ \left(\frac{i^2}{K^2} + \frac{s^2}{K^2} \right) m_y - 2 \left(\frac{F}{MK} \right) \frac{s}{K} \right\} \quad (44)$$

$$\alpha_1 = \left\{ \frac{\partial C_L}{\partial \left(\frac{rK}{V_0} \right)} - \mathcal{M}(1 + m_x) \right\} \left\{ (m_x - m_y) \mathcal{M} - \frac{\partial C_N}{\partial \eta} \right\} + \left(C_D + \frac{\partial C_L}{\partial \eta} \right) \frac{\partial C_N}{\partial \left(\frac{rK}{V_0} \right)} - \frac{\partial C_L}{\partial \eta} \left\{ \frac{F}{MK} - m_y \frac{s}{K} \right\} \mathcal{M} \quad (45)$$

$$\alpha_0 = \left\{ \frac{\partial C_N}{\partial \eta} - (m_x - m_y) \mathcal{M} \right\} \mathcal{M} C_D. \quad (46)$$

For the motion to be stable the real roots and the real parts of any complex roots of the frequency equation (42) must be negative. A necessary and sufficient set of conditions for this is that

$$\frac{\alpha_2}{\alpha_3} > 0; \frac{\alpha_0}{\alpha_3} > 0; \alpha_1\alpha_2 - \alpha_0\alpha_3 > 0. \quad (47)$$

An examination of the expressions (43) to (46) for the coefficients of the frequency equation now shows the complexity of the system and in order to make further progress reliable values for the aerodynamic coefficients and the apparent-mass coefficients are required. So little is known concerning these factors that any further assessment of the motion given by equations (40) and (41) is liable to considerable error and in the present report no attempt will be made to carry the analysis any further.

5. Discussion.

It is useful at this stage to list the assumptions made in deriving the theory of the previous sections.

- (1) The parachute system and load is regarded as a rigid body moving through an infinite, incompressible, inviscid and irrotational fluid.
- (2) The system is rotationally symmetric.
- (3) The canopy is imporous.
- (4) The motion can be regarded as occurring in one plane only.
- (5) The load is a point mass.
- (6) Air forces act only on the canopy.
- (7) Axes are specifically chosen so that the only non-vanishing components of the apparent-mass tensor are A , B , F and R .
- (8) The mass of the canopy and rigging lines can be neglected in comparison with that of the load.
- (9) The moment of inertia of the canopy about its centre of gravity can be neglected in comparison with its apparent moment of inertia.
- (10) The canopy mass is negligible in comparison with the apparent-mass coefficient B .

The assumptions (8), (9) and (10) are not necessary and have been introduced in order to simplify the stability equations; (9) and (10) are in any case of rather a dubious nature and it is probably better to include the physical characteristics of the canopy in the equations as well as its apparent features, this is very easily done at the expense of adding several more terms to equations (40) and (41). With regard to assumption (5), the load is of high density and small in volume in most practical cases, thus its apparent-mass components should be negligible when referred to its centre of mass. This assumption of point mass implies that the load has no moment of inertia—this can equally be stated as implying that the angular velocity of the canopy is not transmitted to the load.

It has already been remarked that the equations of motion as derived in this report are for a highly idealised system and some comment is necessary on the relation between the case considered and that which occurs physically. When a body is accelerated in a fluid, either real or ideal, it behaves as if it possessed an additional mass. In an ideal fluid this additional mass can be represented by a tensor with constant coefficients—the apparent-mass coefficients A , B , F , R etc. as used in the present analysis. In a real fluid the evidence, particularly that of Luneau³, suggests that in general the apparent mass is a function of velocity and acceleration and higher time derivatives of the

displacement and that the order of magnitude for a given body can be greatly different from the estimates obtained on a basis of potential-flow theory. Even if we make the assumption that the additional-mass-tensor concept can be used with regard to a real fluid and that its components are constant to a first approximation, the problem remains of estimating reasonable values. Too little work has, as yet, been done experimentally on accelerated motion in a fluid and certainly little is known of the behaviour of a parachute in unsteady motion. Essentially we are dealing with the flow past a body with a large turbulent wake and little is known of the fluid dynamics of the wake behind a body of simple formation let alone such a complicated system as a porous, flexible parachute. Whilst we should not be discouraged from attempting theoretical analysis and its experimental verification it is essential to realise the limitations involved and under the circumstances not to expect much agreement between theory and experiment.

The object of the present report has been to draw attention to the deficiencies in the previous treatments of parachute stability; it does not pretend to produce a new theory or be constructive in its criticism but merely endeavours to place the subject in some sort of perspective from a theoretical viewpoint.

6. *Conclusions.*

- (1) The equations of parachute motion, as given by Henn, are erroneous.
- (2) The theory is based on the behaviour of a model in an idealised fluid. The theoretical concept of apparent mass with regard to the motion of a body in this fluid is not necessarily adequately representative of the physical phenomena occurring in a real fluid. Theoretically the apparent-mass coefficients are constant functions of the configuration of the body but, in practice, they have been found to vary with the derivatives with respect to time of the displacement.
- (3) Experimental investigation of the apparent-mass concept in relation to the parachute is desirable in order to assess the extent of the validity of the theoretical model.

LIST OF SYMBOLS

A, B, C, F, G, R	Components of the apparent-mass tensor referred to an origin O'
h	Distance from the load point to the centre of gravity of the parachute canopy
i	Defined by $i^2 = R/B$
K	Inflated-canopy radius
(l, m)	Direction cosines
(p, q, r)	Angular velocity components
(u, v, w)	Translational velocity components
(X, Y, Z)	Extraneous force components
(L, M, N)	Extraneous couple components
(ξ, η, ζ)	Force components of a wrench
(λ, μ, ν)	Couple components of a wrench
p_x, p_y	Linear momentum components
h_z	Angular momentum about the z -axis
m	Mass of canopy and rigging lines
M	Mass of load
m_x, m_y	Non-dimensional mass ratios
\mathcal{M}	Mass-effect number
I	Moment of inertia of canopy about an axis through its centre of gravity perpendicular to the x, y -plane
V_0	Descent velocity
s	Distance along the parachute axis between the load point and the origin O'
t	Time
α_i	Coefficients of the frequency equation
γ	Angle the parachute axis makes with the vertical
δ	Angle the velocity vector makes with the vertical
$\eta = \gamma - \delta$	$\eta = \gamma - \delta$, see Fig. 3
τ	A non-dimensionalised time scale
ρ	Fluid density
$\varphi, \varphi_1, \varphi_2, \varphi_3$	Potential functions
T	Kinetic energy of fluid
T_1	Kinetic energy of solid
$\mathcal{T} = T + T_1$	$\mathcal{T} = T + T_1$, total kinetic energy
C_D	A drag coefficient
C_L	A lift coefficient
C_N	A moment coefficient

Duplicate use has been made of some symbols but as definitions are given throughout the text no ambiguities should arise and the symbol intended should be obvious from its context.

REFERENCES

General

H. Lamb *Hydrodynamics.*
6th Edition. Camb. Univ. Press. 1932.

No. Author Title etc.

1 H. Henn Descent characteristics of Parachutes.
R.A.E. Translation No. 233 of German Report ZWB/UM/6202.
October, 1944.

2 W. D. Brown *Parachutes.*
1st Edition. Pitman & Sons Ltd., London. 1951.

3 J. L. Luneau Sur l'influence de l'accélération sur la résistance au mouvement dans
les fluides.
Publ. Sci. Min. Air. No. 363.
Paris, France. 1960.

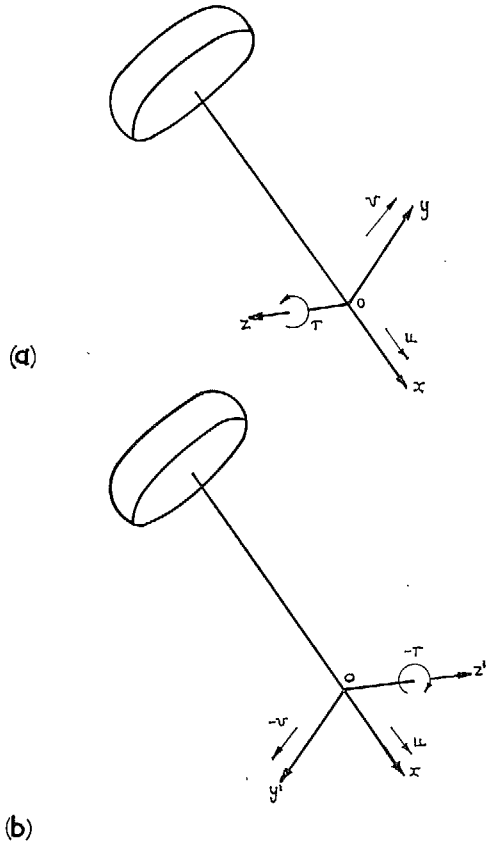

Figs. 1a and b.

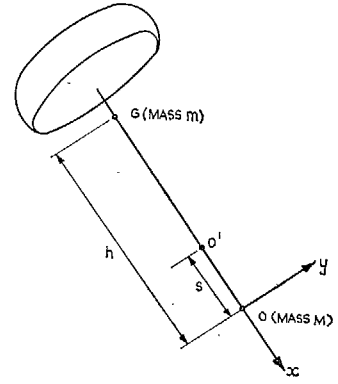

FIG. 2.

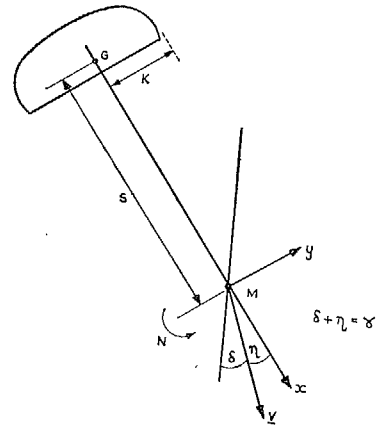

FIG. 3.

Publications of the Aeronautical Research Council

ANNUAL TECHNICAL REPORTS OF THE AERONAUTICAL RESEARCH COUNCIL (BOUND VOLUMES)

- 1942 Vol. I. Aero and Hydrodynamics, Aerofoils, Airscrews, Engines. 75s. (post 2s. 9d.)
Vol. II. Noise, Parachutes, Stability and Control, Structures, Vibration, Wind Tunnels. 47s. 6d. (post 2s. 3d.)
- 1943 Vol. I. Aerodynamics, Aerofoils, Airscrews. 80s. (post 2s. 6d.)
Vol. II. Engines, Flutter, Materials, Parachutes, Performance, Stability and Control, Structures. 90s. (post 2s. 9d.)
- 1944 Vol. I. Aero and Hydrodynamics, Aerofoils, Aircraft, Airscrews, Controls. 84s. (post 3s.)
Vol. II. Flutter and Vibration, Materials, Miscellaneous, Navigation, Parachutes, Performance, Plates and Panels, Stability, Structures, Test Equipment, Wind Tunnels. 84s. (post 3s.)
- 1945 Vol. I. Aero and Hydrodynamics, Aerofoils. 130s. (post 3s. 6d.)
Vol. II. Aircraft, Airscrews, Controls. 130s. (post 3s. 6d.)
Vol. III. Flutter and Vibration, Instruments, Miscellaneous, Parachutes, Plates and Panels, Propulsion. 130s. (post 3s. 3d.)
Vol. IV. Stability, Structures, Wind Tunnels, Wind Tunnel Technique. 130s. (post 3s. 3d.)
- 1946 Vol. I. Accidents, Aerodynamics, Aerofoils and Hydrofoils. 168s. (post 3s. 9d.)
Vol. II. Airscrews, Cabin Cooling, Chemical Hazards, Controls, Flames, Flutter, Helicopters, Instruments and Instrumentation, Interference, Jets, Miscellaneous, Parachutes. 168s. (post 3s. 3d.)
Vol. III. Performance, Propulsion, Seaplanes, Stability, Structures, Wind Tunnels. 168s. (post 3s. 6d.)
- 1947 Vol. I. Aerodynamics, Aerofoils, Aircraft. 168s. (post 3s. 9d.)
Vol. II. Airscrews and Rotors, Controls, Flutter, Materials, Miscellaneous, Parachutes, Propulsion, Seaplanes, Stability, Structures, Take-off and Landing. 168s. (post 3s. 9d.)
- 1948 Vol. I. Aerodynamics, Aerofoils, Aircraft, Airscrews, Controls, Flutter and Vibration, Helicopters, Instruments, Propulsion, Seaplane, Stability, Structures, Wind Tunnels. 130s. (post 3s. 3d.)
Vol. II. Aerodynamics, Aerofoils, Aircraft, Airscrews, Controls, Flutter and Vibration, Helicopters, Instruments, Propulsion, Seaplane, Stability, Structures, Wind Tunnels. 110s. (post 3s. 3d.)

Special Volumes

- Vol. I. Aero and Hydrodynamics, Aerofoils, Controls, Flutter, Kites, Parachutes, Performance, Propulsion, Stability. 126s. (post 3s.)
- Vol. II. Aero and Hydrodynamics, Aerofoils, Airscrews, Controls, Flutter, Materials, Miscellaneous, Parachutes, Propulsion, Stability, Structures. 147s. (post 3s.)
- Vol. III. Aero and Hydrodynamics, Aerofoils, Airscrews, Controls, Flutter, Kites, Miscellaneous, Parachutes, Propulsion, Seaplanes, Stability, Structures, Test Equipment. 189s. (post 3s. 9d.)

Reviews of the Aeronautical Research Council

1939-48 3s. (post 6d.) 1949-54 5s. (post 5d.)

Index to all Reports and Memoranda published in the Annual Technical Reports

1909-1947 R. & M. 2600 (out of print)

Indexes to the Reports and Memoranda of the Aeronautical Research Council

Between Nos. 2351-2449	R. & M. No. 2450 2s. (post 3d.)
Between Nos. 2451-2549	R. & M. No. 2550 2s. 6d. (post 3d.)
Between Nos. 2551-2649	R. & M. No. 2650 2s. 6d. (post 3d.)
Between Nos. 2651-2749	R. & M. No. 2750 2s. 6d. (post 3d.)
Between Nos. 2751-2849	R. & M. No. 2850 2s. 6d. (post 3d.)
Between Nos. 2851-2949	R. & M. No. 2950 3s. (post 3d.)
Between Nos. 2951-3049	R. & M. No. 3050 3s. 6d. (post 3d.)
Between Nos. 3051-3149	R. & M. No. 3150 3s. 6d. (post 3d.)

HER MAJESTY'S STATIONERY OFFICE

from the addresses overleaf

© *Crown copyright* 1964

Printed and published by
HER MAJESTY'S STATIONERY OFFICE

To be purchased from
York House, Kingsway, London W.C.2
423 Oxford Street, London W.1
13A Castle Street, Edinburgh 2
109 St. Mary Street, Cardiff
39 King Street, Manchester 2
50 Fairfax Street, Bristol 1
35 Smallbrook, Ringway, Birmingham 5
80 Chichester Street, Belfast 1
or through any bookseller

Printed in England