

**TECHNICAL MANUAL**

**AVIATION UNIT MAINTENANCE (AVUM)  
AND AVIATION INTERMEDIATE  
MAINTENANCE (AVIM) MANUAL**

**FOR**

**GENERAL AIRCRAFT MAINTENANCE**

**(PNEUDRAULICS MAINTENANCE AND PRACTICES)**

**VOLUME 2**

**\*This manual together with TM 1-1500-204-23-1, TM 1-1500-204-23-3 through TM 1-1500-204-23-10, dated 31 July 1992, supersedes TM 55-1500-204-25/1, dated 6 April 1970, including all changes.**

**DISTRIBUTION STATEMENT A: Approved for public release; distribution is unlimited.**

---

**H E A D Q U A R T E R S , D E P A R T M E N T O F T H E A R M Y  
3 1 J U L Y 1 9 9 2**

**This copy is a reprint which includes current pages from Changes 1 and 2.**

## PRECAUTIONARY DATA

Personnel performing instructions involving operations, procedures, and practices which are included or implied in this technical manual shall observe the following instructions. Disregard of these warnings and precautionary information can cause serious injury, death, or an aborted mission.

WARNINGS, CAUTIONS, and NOTES are means of attracting attention to essential or critical information in a manual. Definitions are outlined as follows:

### **WARNING**

An operating or maintenance procedure, practice, condition, statement, etc., which if not strictly observed, could result in injury to or death of personnel.

### **CAUTION**

An operating or maintenance procedure, practice, condition, statement, etc., which if not strictly observed, could result in damage to, or destruction of equipment or loss of mission effectiveness or long term health hazards to personnel.

### **NOTE**

An essential operating or maintenance procedure, condition, or statement, which must be highlighted.

### **WARNING**

#### **USING SOLVENTS/PAINTS**

Standard precautions such as fire prevention and adequate ventilation shall be exercised when using solvents or applying primer and coating.

Wear gloves or gauntlets when handling solvents as solvents may cause skin disorders.

Follow the Permissible Exposure Limit (PEL) and use Personal Protective Equipment (PPE) as outlined in NIOSH/OSHA Occupational Health Guidelines for Chemical Hazards.

Store in nonflammable storage cabinets when not in use.

### **WARNING**

#### **HOT BRAKES**

If it is necessary to approach a wheel with a hot brake, do so either from directly in front or directly behind the aircraft.

TM 1-1500-204-23-2

**WARNING**

**GROUND SUPPORT EQUIPMENT**

Always operate all equipment in accordance with the operator's manual.

To prevent accidental falls, appropriate maintenance platforms/safety stands illustrated in appropriate workstand manuals or any other approved locally procured/manufactured safety stands/restraint equipment will be used when working (above 4 feet) on aircraft in a non-tactical environment.

Install safety lock when an adjustable-height maintenance platform is in use.

Ensure the air hose used with compressed air is safe for the pressure being handled.

**WARNING**

**FIRE EXTINGUISHERS**

Monobromotrifluoromethane (CF<sup>3</sup>Br) is highly volatile, but not easily detected by odor. Although nontoxic, CF<sup>3</sup>Br shall be considered in the same class as other freons and carbon dioxide, i.e., capable of causing danger to personnel primarily by reduction of oxygen available for proper breathing. The liquid may cause frostbite or low temperature burns if allowed to come in contact with the skin.

Bromochloromethane (CB) is a narcotic agent of moderate intensity, but of prolonged duration. It is considered less toxic than carbon tetrachloride, methylbromide, or the usual products of combustion. Normal precautions should be taken while using bromochloromethane, including the use of oxygen masks.

**WARNING**

**HYDRAULIC FLUID**

To avoid contamination, do not use previously opened cans of hydraulic fluid. A new, sealed can of fluid must be opened and used. When opening can, clean top and use a clean sharp, unplated instrument to prevent contamination.

**WARNING**

**COMPRESSED AIR**

Compressed air shall not be used for cleaning purposes unless reduced to less than 30 psi and then only with effective chip-guarding and personal protective equipment.

**WARNING**

**NOISE HAZARD**

Noise levels reached during ground runup of Army aircraft are of a level that may cause permanent hearing loss. Maintenance personnel shall wear adequate hearing protection when working on aircraft with engines in operation.

**WARNING**

**PROPER USE OF PLATED TOOLS**

Use only chrome plated steel or unplated steel tools for disassembly or reassembly procedures described in this manual. Use of cadmium or zinc plated tools is not permitted since these platings are prone to chipping and flaking. Should these chips or flakes become embedded in aircraft parts, galvanic corrosion will result. Should these chips or flakes enter fuel or oil wetted components, they may eventually clog the filter or produce intergranular attack of nickel or titanium base alloys at elevated temperature. All tools regardless of type plating should be serviceable and free of chipping.

**WARNING**

**SPECIAL INSTRUCTIONS**

All equipment must be operated per the manufacturer's operating instructions. If unavailable, instructions for the use and care will be developed. SOPs will be prepared and used for all shop operations (refer to AR 385-95). The supporting Safety Office will use their expertise to provide assistance. Guidance for industrial hazards can be found in Code of Federal Regulations 29 CFR 1910, and Chemical Hazards in NIOSH/OSHA Guidelines for Chemical Hazards.

**WARNING**

**CLEANING COMPOUND, MIL-PRF-87937, TYPE II**

Cleaning compounds can irritate eyes and skin. Wear protective gloves and goggles. Avoid repeated or prolonged contact.

**WARNING**

**ALIPHATIC NAPHTHA**

Aliphatic Naphtha is extremely flammable and toxic to eyes, skin and respiratory tract. Wear protective gloves and goggles/shield. Avoid repeated or prolonged contact. Use only in well ventilated areas (or use approved respirator as determined by local safety/industrial hygiene personnel). Keep away from open flame other sources of ignition.

**WARNING**

**DEGREASING SOLVENT, MIL-PRF-680**

Degreasing solvent, MIL-PRF-680, is combustible and toxic to eyes, skin and respiratory tract. Wear protective gloves and goggles/face shield. Avoid repeated or prolonged contact. Use only in well ventilated areas (or use approved respirator as determined by local safety/industrial hygiene personnel). Keep away from open flame other sources of ignition.

**WARNING**

**n-PROPYL BROMIDE**

n-Propyl Bromide is toxic to eyes, skin, and respiratory tract. Wear protective gloves and goggles/face shield. Avoid repeated or prolonged contact. Use only in areas with adequate mechanical or local exhaust ventilation (or use approved respirator as determined by local safety/industrial hygiene personnel).

**WARNING**

**DENATURED ALCOHOL**

Denatured alcohol is flammable and toxic to eyes skin and respiratory tract. Wear chemical protective gloves and goggles/face shield. Avoid repeated or prolonged contact. Use only in well ventilated areas. If ventilation is not adequate, use approved respirator as determined by local safety/industrial hygiene personnel. Keep away from open flames, welding or other sources of ignition.

**WARNING**

**HFE-71DE**

HFE-71DE is toxic to eyes, skin and respiratory tract and decomposes into other hazardous products when exposed to extreme heat. Wear chemical protective gloves and goggles/face shield. Avoid repeated or prolonged contact. Use only in well ventilated areas. If ventilation is not adequate, use approved respirator as determined by local safety/industrial hygiene personnel. Keep away from open flames, welding or other sources of ignition.

TM 1-1500-204-23-2

**WARNING**

**ISOPROPYL ALCOHOL**

Isopropyl alcohol is flammable and toxic to eyes, skin and respiratory tract. Wear protective gloves and goggles/shield. Avoid repeated or prolonged contact. Use only in well ventilated areas (or use approved respirator as determined by local safety/industrial hygiene personnel). Keep away from open flame other sources of ignition.

# URGENT

CHANGE

NO. 4

HEADQUARTERS  
DEPARTMENT OF THE ARMY  
WASHINGTON, DC., 12 January 2010

## AVIATION UNIT MAINTENANCE (AVUM) AND AVIATION INTERMEDIATE MAINTENANCE (AVIM) MANUAL FOR GENERAL AIRCRAFT MAINTENANCE (PNEUDRAULICS MAINTENANCE AND PRACTICES) VOLUME 2

(NSN ) (EIC: NA)

This document has been reviewed for the presence of Class I Ozone Depleting Chemicals by the AMCOM G-4 (Logistics) Environmental Division. As of the base through C03, dated 29 January 1999, all references to Class I Ozone Depleting Chemicals have been removed from this document by substitution with chemicals that do not cause atmospheric ozone depletion EXCEPT Bromotrifluoromethane (CF3BR); Fire Extinguisher Agent (Halon 1301).

This document has been reviewed for the presence of SOLVENTS containing hazardous materials as defined by the EPCRA 302 and 313 lists by the AMCOM G-4 (Logistics) Environmental Division. As of the base through C03, dated 29 January 1999, all references to Solvents containing hazardous materials have been removed from this document by substitution with non-hazardous or less hazardous materials where possible.

DISTRIBUTION STATEMENT A: Approved for public release; distribution is unlimited.

TM 1-1500-204-23-2, Dated 31 July 1992, is changes as follows:

1. Remove and insert pages as indicated below. New or changed text material is indicated by a vertical bar in the margin. An illustration change is indicated by a miniature pointing hand.

### Remove Pages

a through c/(d blank)

-----

i/(ii blank)

3-1 through 3-4

-----

3-7 and 3-8

3-9 and 3-10

4-5 and 4-6

-----

4-9 and 4-10

-----

4-25 and 4-26

-----

4-51 through 4-54

4-59 and 4-60

-----

4-74.1 and 4-47.2

4-87 through 4-100

-----

4-101 through 4-104

4-107 and 4-108

-----

4-117 and 4-118

4-139 and 4-140

-----

### Insert Pages

a through d

A and B

i/(ii blank)

3-1 through 3-4

3-4.1/(3-4.2 blank)

3-7 and 3-8

3-9 and 3-10

4-5 and 4-6

4-6.1/(4-6.2 blank)

4-9 and 4-10

4-10.1/(4-10.2 blank)

4-25 and 4-26

4-26.1/(4-26.2 blank)

4-51 through 4-54

4-59 and 4-60

4-60.1/(4-60.2 blank)

4-74.1 and 4-47.2

4-87 through 4-100

4-100.1 and 4-100.2

4-101 through 4-104

4-107 and 4-108

4-108.1/(4-108.2 blank)

4-117 and 4-118

4-139 and 4-140

4-140.1/(4-140.2 blank)

**TM 1-1500-204-23-2**  
**C4**

2. Retain this sheet in front of manual for references purposes.

CHANGE

NO. 3

HEADQUARTERS  
DEPARTMENT OF THE ARMY  
WASHINGTON, D.C., 29 January 1999

**AVIATION UNIT MAINTENANCE (AVUM) AND  
AVIATION INTERMEDIATE MAINTENANCE (AVIM) MANUAL  
FOR  
GENERAL AIRCRAFT MAINTENANCE  
(PNEUDRAULICS MAINTENANCE AND PRACTICES)  
VOLUME 2**

DISTRIBUTION STATEMENT A: Approved for public release: distribution is unlimited

TM 1-1500-204-23-2, 31 July 1992, is changed as follows:

1. Remove and insert pages as indicated below. New or changed text material is indicated by a vertical bar in the margin.

Remove pages

i/ii(blank)

4-1 and 4-2  
4-21 and 4-22  
4-35 and 4-36  
4-69 and 4-70

Insert pages

i/(ii blank)  
3-8.1/(3-8.2 blank)  
4-1 and 4-2  
4-21 and 4-22  
4-35 and 4-36  
4-69 and 4-70

2. Retain this sheet in front of manual for reference purposes.

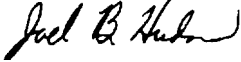


TM 1-1500-204-23-2  
C3

By Order of the Secretary of the Army:

DENNIS J. REIMER  
*General, United States Army*  
*Chief of Staff*

Official:



JOEL B. HUDSON  
*Administrative Assistant to the*  
*Secretary of the Army*  
05555

DISTRIBUTION:

To be distributed in accordance with Initial Distribution Number (IDN) 313302, requirements for TM 1-1500-204-23-2.

CHANGE  
NO. 2

HEADQUARTERS  
DEPARTMENT OF THE ARMY  
WASHINGTON, D.C., 1 FEBRUARY 1994

Aviation Unit Maintenance (AVUM) and  
Aviation Intermediate Maintenance (AVIM) Manual  
for  
GENERAL AIRCRAFT MAINTENANCE  
(PNEUDRAULICS MAINTENANCE AND PRACTICES)  
VOLUME 2

DISTRIBUTION STATEMENT A: Approved for public release; distribution is unlimited.

TM 1-1500-204-23-2, 31 July 1992, is changed as follows:

1. Remove and insert pages as indicated below. New or changed text material is indicated by a vertical bar in the margin. An illustration change is indicated by a miniature pointing hand.

Remove pages

4-65 and 4-66

4-71 and 4-72

-----

4-75 and 4-76

-----

4-169/(4-170 blank)

Insert pages

4-65 and 4-66

4-71 and 4-72

4-74.1 and 4-74.2

4-75 and 4-76

4-76.1/(4-76.2 blank)

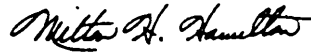
4-169/(4-170 blank)

2. Retain this sheet in front of manual for reference purposes.

By Order of the Secretary of the Army:

GORDON R. SULLIVAN  
*General, United States Army*  
*Chief of Staff*

Official:



MILTON H. HAMILTON  
*Administrative Assistant to the*  
*Secretary of the Army*  
06311

Distribution:

To be distributed in accordance with DA Form 12-31-E, block no. 3302, requirements for TM 1-1500-204-2 3-2.

CHANGE  
NO. 1

HEADQUARTERS  
DEPARTMENT OF THE ARMY  
WASHINGTON, D.C., 30 JUNE 1993

Aviation Unit Maintenance (AVUM) and  
Aviation Intermediate Maintenance (AVIM) Manual  
for  
GENERAL AIRCRAFT MAINTENANCE  
(PNEUDRAULICS MAINTENANCE AND PRACTICES)  
VOLUME 2

DISTRIBUTION STATEMENT A: Approved for public release; distribution is unlimited.

TM 1-1500-204-23-2, 31 July 1992, is changed as follows:

1. Remove and insert pages as indicated below. New or changed text material is indicated by a vertical bar in the margin. An illustration change is indicated by a miniature pointing hand.

Remove pages

i/(ii blank)  
4-1 through 4-4  
4-25 and 4-26  
4-35 and 4-36  
4-73 and 4-74

Insert pages

i/(ii blank)  
4-1 through 4-4  
4-25 and 4-26  
4-35 and 4-36  
4-73 and 4-74

2. Retain this sheet in front of manual for reference purposes.

By Order of the Secretary of the Army:

Official

MILTON H HAMILTON  
Administrative Assistant to the  
Secretary of the Army  
04458

GORDON R SULLIVAN  
General, United States Army  
Chief of Staff

DISTRIBUTION:

To be distributed in accordance with DA Form 12-31-E, block no. 3302, requirements for TM 1-1500-204-23-2.

## LIST OF EFFECTIVE PAGES

Insert latest changed pages. Dispose of superseded pages in accordance with regulations.

**NOTE:** On a changed page, the portion of the text affected by the latest change is indicated by a vertical line, or other change symbol, in the outer margin of the page. Changes to illustrations are indicated by miniature pointing hands. Changes to wiring diagrams are indicated by shaded areas.

**Dates of issue for original and changed pages are:**

Original ..... 31 July 1992	Change 3.....29 January 1999
Change 1..... 30 June 1993	Change 4.....12 January 2010
Change 2..... 1 February 1994	

**TOTAL NUMBER OF PAGES IN THIS PUBLICATION IS 256, CONSISTING OF THE FOLLOWING:**

Page No.	*Change No.	Page No.	*Change No.
Cover.....	0	4-25 – 4-26.....	4
blank.....	0	4-26.1 added.....	4
a – d.....	4	4-26.2 added blank.....	4
A and B.....	4	4-27 – 4-34.....	0
i.....	4	4-35.....	3
ii blank.....	3	4-36 – 4-50.....	0
1-1.....	0	4-51.....	4
1-2 blank.....	0	4-52.....	0
2-1 – 2-7.....	0	4-53.....	4
2-8 blank.....	0	4-54 – 4-58.....	0
3-1 – 3-4.....	4	4-59 – 4-60.....	4
3-4.1 added.....	4	4-60.1 added.....	4
3-4.2 added blank.....	4	4-60.2 added blank.....	4
3-5 – 3-6.....	0	4-61 – 4-65.....	0
3-7.....	4	4-66.....	2
3-8.....	0	4-67 – 4-68.....	0
3-8.1.....	3	4-69.....	3
3-8.2 blank.....	3	4-70 – 4-71.....	0
3-9 – 3-10.....	4	4-72.....	2
4-1.....	3	4-73.....	1
4-2 – 4-4.....	1	4-74.....	0
4-5.....	0	4-74.1.....	4
4-6.....	4	4-74.2.....	2
4-6.1 added.....	4	4-75.....	2
4-6.2 blank added.....	4	4-76.....	0
4-7 – 4-8.....	0	4-76.1 added.....	4
4-9 – 4-10.....	4	4-76.2 added blank.....	4
4-10.1 added.....	4	4-77 – 4-86.....	0
4-10.2 added blank.....	4	4-87 4-100.....	4
4-11 – 4-20.....	0	4-100.1 – 4-100.2 added.....	4
4-21.....	3	4-101 – 4-103.....	4
4-22 – 4-24.....	0	4-104 – 4-106.....	0

\*Zero in this column indicated an original page.

**TM 1-1500-204-23-2**

**LIST OF EFFECTIVE PAGES (CON'T)**

<b>Page No.</b>	<b>*Change No.</b>	<b>Page No.</b>	<b>*Change No.</b>
4-107 – 4-108.....	4	4-140.2 added blank .....	4
4-108.1 added .....	4	4-141 – 4-168.....	0
4-108.2 added blank .....	4	4-169.....	2
4-109 – 4-117 .....	0	4-170 blank .....	2
4-118 .....	4	A-1 .....	0
4-119 – 4-138.....	0	A-2 blank.....	0
4-139 – 4-140.....	4	Glossary 1 – Glossary 2 .....	0
4-140.1 added .....	4	Index 1 – Index 20 .....	0

\*Zero in this column indicated an original page.  
**B Change 4**

TECHNICAL MANUAL

No. 1-1500-204-23-2

HEADQUARTERS  
DEPARTMENT OF THE ARMY  
WASHINGTON, D.C., 31 JULY 1992

**TECHNICAL MANUAL  
AVIATION UNIT MAINTENANCE (AVUM) AND AVIATION INTERMEDI-  
ATE MAINTENANCE (AVIM) MANUAL  
FOR  
GENERAL AIRCRAFT MAINTENANCE (PNEUDRAULICS MAINTENANCE  
AND PRACTICES) VOLUME 2**

**REPORTING ERRORS AND RECOMMENDING IMPROVEMENTS**

You can improve this manual. If you find mistakes, or if you know of a way to improve these procedures, please let us know. Mail your letter or DA Form 2028 (Recommended Changes to Publications and Blank Forms) located in the back of this manual, directly to: Commander, U.S. Army Aviation and Missile Command, ATTN: AMSAM-MMA-NP, Redstone Arsenal, AL 35898-5000. A reply will be furnished to you. You may also provide DA Form 2028 information to AMCOM via e-mail, fax, or the World Wide Web. Our fax number is DSN 788-6546 or Commercial (256) 842-6546. Our e-mail address is: 2028@redstone.army.mil. Instructions for sending an electronic 2028 may be found at the back of this manual immediately preceding the hard copy 2028. For the World Wide Web use: <https://amcom2028.redstone.army.mil>.

**OZONE DEPLETING CHEMICALS INFORMATION**

This document has been reviewed for the presence of Class I Ozone Depleting Chemicals by the AMCOM G-4 (Logistics) Environmental Division. As of the base through C03, dated 29 January 1999, all references to Class I Ozone Depleting Chemicals have been removed from this document by substitution with chemicals that do not cause atmospheric ozone depletion EXCEPT Bromotrifluoromethane (CF3BR); Fire Extinguisher Agent (Halon 1301).

**HAZARDOUS MATERIAL INFORMATION**

This document has been reviewed for the presence of SOLVENTS containing hazardous materials as defined by the EPCRA 302 and 313 lists by the AMCOM G-4 (Logistics) Environmental Division. As of the base through C03, dated 29 January 1999, all references to Solvents containing hazardous materials have been removed from this document by substitution with non-hazardous or less hazardous materials where possible.

**TABLE OF CONTENTS**

	<b>Page</b>
CHAPTER 1 INTRODUCTION .....	1-1
CHAPTER 2 PNEUDRAULICS GENERAL .....	2-1
CHAPTER 3 HYDRAULIC SHOP OPERATIONS .....	3-1
CHAPTER 4 HYDRAULIC MAINTENANCE PRACTICES .....	4-1
APPENDIX A REFERENCES .....	A-1
GLOSSARY .....	Glos- sary-1
INDEX .....	Index-1





## CHAPTER 1

### INTRODUCTION

**1-1. Purpose.** This volume provides general information pertaining to aircraft hydraulic and pneumatic systems. The application of materials and techniques used on specific aircraft is not covered In this volume. Specific aircraft application, usage, and substitution are found in the individual aircraft maintenance manuals This volume is of maximum benefit to the mechanic who desires information about tubing systems, flexible hoses, packings and O-rings, and aircraft system components. This volume furnishes the mechanic a source of information about how to perform various mechanical functions which are used on all aircraft This volume is not a requisitioning authority, and applicable repair parts and special tools list should be consulted to obtain the unit of Issue and National Stock Number of the Items required for maintenance.

**1-2. Scope.** General information to guide aircraft maintenance personnel is covered within this volume; however, no attempt has been made to include special parts or equipment which are applicable only to individual or specific aircraft General information on aircraft hydraulic systems is contained In Chapter 2 and hydraulic shop operations are discussed in Chapter 3. Procedures, techniques, and materials for maintenance of tubing, hoses, packings, O-rings, reservoirs, filters, pumps, accumulators, valves, brake systems, and absorbing units are presented in Chapter 4.

**1-3. Consumable Materials.** Refer to TM 1- 1500-204-23-6 for consumable materials in this volume.

## CHAPTER 2

### PNEUDRAULICS GENERAL

**2-1. Pneudraulics Theory and Basic Principles.** The aircraft hydraulic system transmits engine power to distant points on the aircraft. This force is carried by hydraulic fluid confined in a system of tubing and hoses

a. Qualities of Hydraulic Fluid. Hydraulic fluid can be described in terms of three physical qualities

(1) Incompressibility. For practical purposes, liquids are incompressible. This means that even under extremely high pressure a liquid cannot be made much smaller.

(2) Expansion and contraction. Liquids expand and contract with changes in temperature. When a liquid in a closed container is heated, the liquid expands and puts pressure on the walls of the container. As the liquid cools, the pressure decreases.

(3) Pressure transmission. Pressure applied to a confined liquid is transmitted equally. If an opening exists in a system, such as an actuator, the fluid will act on it, causing it to move.

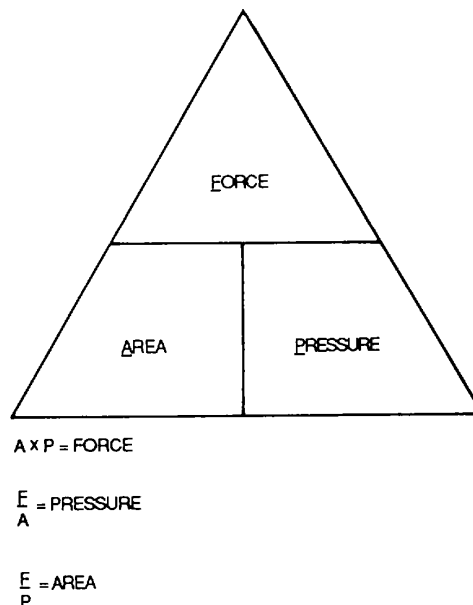
b. Computation of Force, Area, and Pressure. Hydraulic systems are designed to take advantage of the characteristics of liquids as they relate to force, area and pressure. These terms as used in hydraulics are defined as follows:

(1) Force. Force is the amount of push or pull applied to an object. The force applied to a piston head, for example, is the energy applied to the total area of the piston head. In this manual, we measure force in pounds.

(2) Area. Area is the measurement of a surface. In the aircraft hydraulic system, we are concerned with the areas of piston heads. If we know this area, we can compute the amount of force needed to start a mechanism moving. In this manual, area is measured in square inches.

(3) Pressure. Pressure is the force applied to one unit of area—usually 1 square inch. The pressure on a piston head develops the force that operates a mechanism. In our work, we measure pressure in pounds per square inch (psi).

(4) Computation. If you know any two of these factors, you can easily compute the third by using the equation illustrated in figure 2-1. To apply this equation, multiply the two lower factors together to get the top factor, and divide the top factor by the known lower factor to get the unknown lower factor.



**Figure 2-1. Computing Force Pressure, and Area**

(a) Force computation. The force (F) in pounds can be obtained by multiplying the known values of area (A) and pressure (P).

(b) Pressure computation. Similarly, if the force (F) and area (A) are known, F can be divided by A to obtain pressure (P) In pounds per square inch.

(c) Area computation. Finally, to obtain area In square inches, force (F) is divided by pressure (P)

c. Computation of Volume, Area, and Length of Stroke. You can use the same type of triangular equation to compute volume, area, and length of stroke. The following definitions apply for this manual.

(1) Volume. Volume is a measurement of quantity expressed in cubic inches, for example, the amount of liquid in a cylinder or the amount of liquid displaced by a pump or an actuating cylinder.

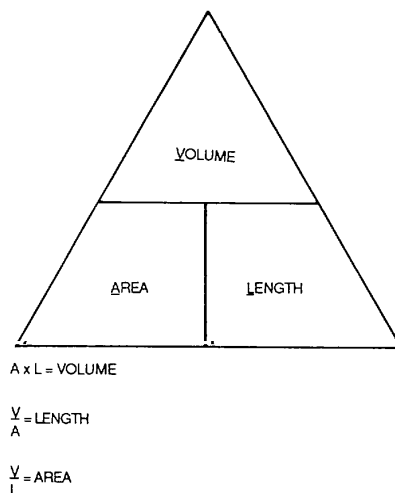
(2) Area. As in the previous equation, area is a surface measurement expressed in square inches.

(3) Length of stroke. Length of stroke is a measurement of distance expressed in inches. The stroke length with which you will be concerned in this manual is the distance a piston moves in a cylinder.

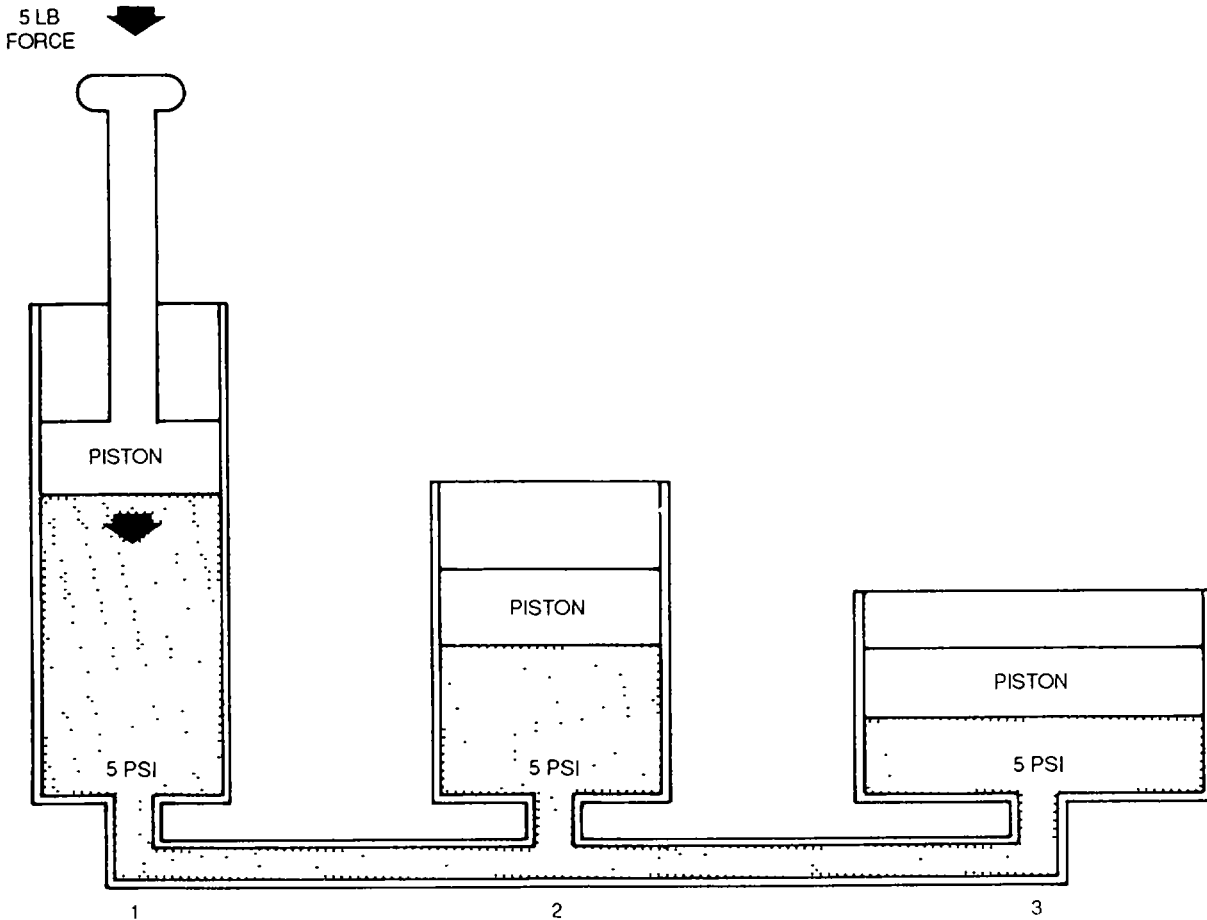
(4) Computation. If you know any two of these factors, you can compute the third (see figure 2-2). As in the previous equation, multiply the two lower factors together to obtain the top factor and divide the top factor by the known lower factor to obtain the unknown lower factor. For example, a piston having an area of 8 square inches moves a distance of 10 inches within a cylinder. To find the volume of liquid moved, multiply the two lower factors together-8 square inches (A) times 10 inches (L)- to obtain V: 80 cubic inches

d. Pascal's Law. Practical applications of hydraulic principles are based on Pascal's law, which may be stated in simple terms as follows: when a force is applied to a confined fluid, the pressure is transmitted equally in all directions. Pascal's law applies for confined fluids only. It follows then that the law does not apply for fluids in motion since moving fluid is not confined in the true sense of the word. Figure 2-3 shows graphic illustration of how Pascal's law applies in an aircraft hydraulic system. Note that when a force is applied to the piston in cylinder 1, it is transmitted to all portions of the confined fluid. If, for example, the applied force is 5 psi, the pressure In cylinders 1, 2, and 3 and in the tubing will be 5 psi. But suppose a change takes place in which a lack of resistance causes either piston 2 or 3, or both, to move upward. This momentarily lowers the pressure in cylinders 2 and 3 while in cylinder 1 it is still 5 psi. This unbalanced condition cannot last. Fluid will flow from cylinder 1 to cylinders 2 and 3. This is because pistons 2 and 3 are not confining the fluid as long as they move upward. Pascal's law does not apply to this condition. When pistons 2 and 3 reach the end of their strokes, the fluid stops flowing. At this point the fluid is again confined and the pressure again equalizes-Pascal's law applies once more.

e. Mechanical Advantage. In simple terms, mechanical advantage is defined as the use of a small force over a great distance to obtain a great force over a short distance. In other words, it is the amount by which the input effort is multiplied in the output of a device. Using a claw hammer to remove a nail from a two-by-four piece of lumber or using a jack to raise a vehicle are examples of mechanical advantage. The aircraft hydraulic system is designed to make full use of this principle since it is a system for transmitting engine power to distant points in the aircraft where power is needed. This is accomplished by multiplying the input effort (or force) enough to do the required job-in other words, gaining a mechanical advantage.



**Figure 2-2. Computing Volume, Length, and Area**



**Figure 2-3. Pascal's Law**

(1) Principle. In hydraulics, mechanical advantage can be explained as the ratio between two pistons with regard to the factors of area and force. In figure 2-4, you see a graphic illustration of this principle. Note the differences in the areas of the small and large pistons. This difference in size is the means by which mechanical advantage is obtained when a 50-pound force is applied to the small pistons, the fluid pressure shows 25 psi on the gauge, but 25 psi acting on the large piston gives an upward force of 250 pounds. This gain in force (from 50 pounds to 250 pounds) is attained by increasing the surface area of the output piston. It is important to note that this 5-to-1 ratio does not change if the pounds per square inch change. If, for example, the input force were limited to 20 psi or raised to 30 psi, the forces involved would obviously change but the ratio between the forces would still be 5 to 1.

(2) Application. An example of how to apply mechanical advantage is shown in figure 2-5. Here we want to find just how big the large piston must be to raise an 800-pound weight. Let us assume that we must raise the 800-pound weight by applying a 40-pound force to the 4-square-inch piston. The mechanical advantage in this case is 20-800 pounds divided by 40 pounds and is expressed as the ratio 20 1. Multiplying 20 times 4 square inches (area of the small piston), we find that the area of the large piston should be 80 square inches. Mechanical advantage also applies to the distance the piston moves, or length of stroke. Assuming that the large piston must move 10 inches, multiplying this factor by 20 gives 200 inches as the length of stroke for the small piston. Of course, it would not be feasible for the small piston to move that far on a single stroke. Therefore, the small piston must move through a series of short repeated strokes.

f. Use of Air in Hydraulic Systems. When subjected to an applied force, a gas (such as air or nitrogen) acts in a manner similar to a spring: it yields but pushes back with as much force as is being applied to it. This characteristic of gases makes them useful in aircraft systems.

(1) Gases used. Air is the gas commonly used in hydraulic systems. It is used in accumulators, shock struts, and emergency systems and for pressurizing system reservoirs. In terms of compressibility, almost any gas could be used, but many are dangerous because they are flammable or explosive. Pure nitrogen is the only safe substitute for atmospheric air in hydraulic systems, and it is the only substitute authorized.

(2) Boyle's law. Assuming a constant temperature, the volume of a confined gas changes in opposite order to changes in pressure. For example, if a given volume of gas is reduced to half its initial size, its pressure doubles or, if the volume doubles, the pressure is halved. This characteristic of gases is known as Boyle's law and is expressed by the equation:

$$V \times P = V^1 \times P^1$$

where  
 V = initial volume  
 P = initial pressure  
 V<sup>1</sup> = changed volume  
 P<sup>1</sup> = changed pressure

If the measurements of any three of these factors are known, the fourth factor can be determined. To illustrate, let us assume that 30 cubic inches of gas (V) at a constant temperature and under 90-psi pressure (P) is forced into a 15-cubic-inch space (V<sup>1</sup>). To find the changed pressure (p<sup>1</sup>) we substitute in the equation as follows.

$$90 \times 30 = 15 \times P^1$$

$$2700 = 15P^1$$

$$\frac{2700}{15} = p^1$$

$$180 = p^1$$

**2-2. Uses of Hydraulic Systems in Army Aircraft.** Hydraulic systems perform a variety of functions in Army aircraft. They are used in fixed-wing aircraft for such purposes as changing propeller pitch and operating landing gear, wing flaps, wheel brakes, and shock struts in helicopters, hydraulic systems start engines and operate brakes, shock struts, dampers, flight control systems, loading ramps, folding pylons, winch hoists, and hydraulic clutches. There are a number of reasons why hydraulic systems have been designed for so many uses in aircraft.

a. Efficiency. A hydraulic system is almost 100 percent efficient. The slight loss of efficiency (a fraction of 1 percent) is due to internal friction in the system machinery.

b. Ease of Operation. The moving parts of a hydraulic system, being light in weight, can be quickly put into motion or brought to rest. The valves used in a hydraulic system are capable of quickly starting or stopping the flow of fluid under pressure, and very little effort is needed to operate them. For these reasons, the system is easy for the operator to control.

c. Ease of Installation. Hydraulic lines can be routed almost anywhere. Unlike mechanical systems, which must follow straight pathways, the lines of a hydraulic system can be easily bent around obstructions. The major parts of hydraulic systems can be located in a wide variety of places.

d. Size. Since the components of a hydraulic system are small in comparison with those of other systems, the space requirement is small.

e. Lubrication. Most of the parts of a hydraulic system operate in a bath of oil, making the system self-lubricating.

**2-3 Types Of Hydraulic Fluid Used in Army Aircraft.** Hydraulic fluids are classified generally as vegetable-base, petroleum-base, and synthetic- base.

a. Vegetable-Base Fluid. Vegetable-base fluid is no longer authorized for use in Army aircraft.

b. Petroleum-Base Fluid. Petroleum-base fluid has an odor similar to penetrating oil and is dyed red. Synthetic rubber seals are used with this fluid.

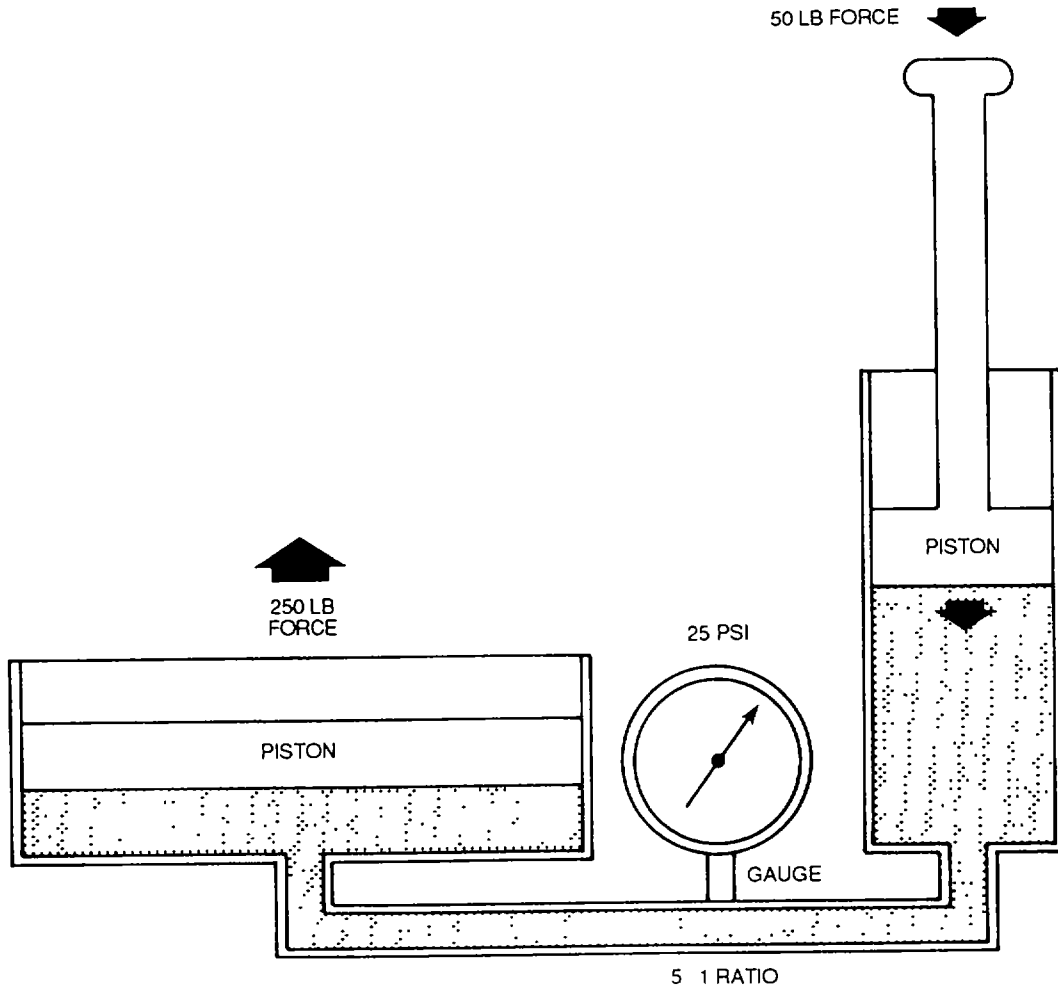


Figure 2-4. Mechanical Advantage

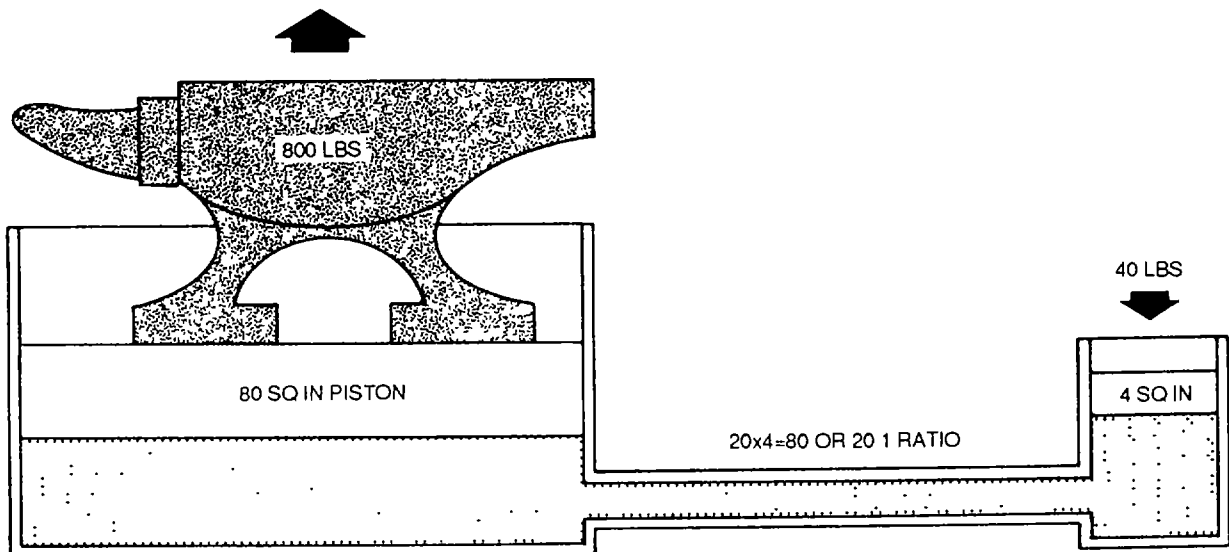


Figure 2-5. Application of Mechanical Advantage

(1) *Petroleum-base fluid MIL-H-6083.* MIL-H-6083 is still authorized for certain uses in Army aircraft. It is used as a preservative oil in shock struts, hydraulic equipment, and spare parts, and as a testing and flushing oil for some components. It should not be used in operational aircraft hydraulic systems.

(2) *Petroleum-base fluid MIL-H-5606.* MIL-H-5606 is being phased out for most Army aircraft, and being replaced with synthetic-base fluid MIL-H-83282. It is, however, still used for cold weather operation. Refer to the following paragraph and paragraph 4-21 for more information on this fluid and its conversion.

c. *Synthetic-Base Fluid MIL-H-83282.* As stated above, MIL-H-5606 is being replaced in most operations by MIL-H-83282. MIL-H-83282 has a higher flash point and fire point, as well as additives which provide better anti-wear characteristics and provide better resistance to corrosion and oxidation. Refer to paragraph 4-21 for more information on this fluid and its conversion.

d. *Precautions.* Use of the correct, uncontaminated fluid in a particular hydraulic system is critical for the continued serviceability of that system.

(1) *Proper fluid.* You must be extremely careful to use only the fluid authorized for a particular component or system. To determine the correct fluid, consult the applicable technical manual. In addition, read the instruction plate affixed to the individual unit or reservoir and check the color of the fluid contained in the system.

(2) *Drained fluid.* Fluid drained, for any reason, from a hydraulic system or component shall not be reused.

(3) *Disposition of containers.* Hydraulic fluid containers, when emptied, shall be destroyed.

**2-4 Fluid Contamination.** Contamination in a hydraulic system is the presence of any material other than the hydraulic fluid being used. This includes water, metal, dust, and other solids. Contamination sources may be internal or external. Internal contamination can cause abnormal wear of the pump or of other components. When filters are used too long (especially the paper element type), particles may begin breaking off from the filter element. Moving seals and backup rings also add contamination to the system. External contamination is generally caused by poor maintenance practices. Examples include leaving hydraulic lines open after removing a part, wiping fittings with dirty rags; leaving valves, tubing, etc., uncovered on workbenches; changing fluid with dirty test equipment, and installing new or rebuilt parts that have not been properly cleaned. Hydraulic fluid (red color), MIL-H-83282 or MIL-H-5606, shall be used in all hydraulic systems. The choice of MIL-H-83282 or MIL-H-5606 depends on the particular hydraulic system and the ambient temperature. Refer to the aircraft manual or to TB 55-1500-334-25.

a. *Detecting Fluid Contamination.* A kit has been developed, part number 57L414, NSN 6630-00-150-6486, to sample fluid for contamination in order to help control contamination in aircraft. Contamination checks should become a routine part of your work. You should check for dirt, metal, and visible solids every time a unit is removed or disassembled. Normal contamination checks for most aircraft are made by examining the condition of the filter elements. For example, a clogged filter or an extended filter indicator pin is a symptom of contaminated fluid. These findings, as well as a pump failure, require flushing of the system.

b. *System Flushing.* Evidence of contamination makes it necessary that hydraulic system be flushed.

### **CAUTION**

To avoid contamination, do not use hydraulic fluid that shows evidence of contamination or is in open cans that are stored uncovered/unprotected. Unused fluid may be kept in filler pumps or sealed jars.

(1) *Fluid.* Hydraulic fluid, MIL-H-5606 or MIL-H-83282, shall be used for flushing systems and components. Discard after use.

(2) *Accidental servicing.* In the event that a system or component is inadvertently serviced with incorrect type fluid, drain fluid, flush system, and replace all packings and gaskets in affected components.

c. *Contamination Prevention.* Contamination can be prevented by taking the following precautions.

(1) Cap or plug all open connections when removing a part.

(2) Never use dirty rags to wipe off connections.

- (3) Clean and deburr new tubing and fittings before installing them.
- (4) Store new or overhauled parts in sealed containers.
- (5) Before installing a pump, fill it with hydraulic fluid.
- (6) Take good care of test stands and ground equipment.
- (7) Handle flexible hydraulic hoses carefully. Particles from their walls enter the system when hoses are kinked or run over or when quick disconnections are not cleaned before being joined.
- (8) Fluid drained, for any reason, from a hydraulic system or component shall not be reused.
- (9) Hydraulic fluid containers, when emptied, shall be destroyed.



## CHAPTER 3

# HYDRAULIC SHOP OPERATIONS

**3-1. GENERAL SHOP RULES.** The practices and procedures described in this chapter pertain to the manufacturing and repair functions of aviation activities and are applicable to all levels of maintenance. Because of the many types of Army aircraft, each shop within the manufacturing and repair section must, of necessity, have personnel trained in general practices and procedures to the extent that different types and model aircraft do not upset a smooth running shop.

**a. Responsibility.** All supervisory personnel in the manufacturing section are responsible for a continuing and effective shop safety program. To implement and maintain this program, shop supervisors will utilize bulletin boards, signs, and any other effective method. Shop personnel will cooperate in the shop safety program by making helpful recommendations, and continually exercising care and caution in the operation of all shop equipment. All shop personnel will strive to improve the safety program and be especially alert to observe and correct hazardous conditions and unsafe shop practices. All accidents, no matter how minor, shall be reported to the shop supervisor, and all published instructions regarding safety shall be strictly adhered to. Also, safety engineers and safety officers will ensure that proper safety procedures are adhered to in accordance with AR 385-10, The Army Safety Program; AR 385-30, Safety Color Code Markings and Signs, AR 385-32, Protective Clothing and Equipment; The Occupational Safety and Health Act of 1971, OSHA 1910.251; all applicable fire codes, NFPA 410; and other accepted civilian and military safety practices.

**b. Shop Housekeeping.** Housekeeping is the yardstick by which the shops in the manufacturing section are judged. A clean, well arranged shop is a safe shop and reflects credit on all personnel concerned with its operation. The following shop practices shall be observed:

(1) Oil pans or drip pans shall be used where leaking oil, grease, and similar materials may cause hazardous accumulations on equipment or floors. All spills shall be cleaned up immediately. Approved sweeping compound may be used to remove these materials from the floor.

### CAUTION

Floors shall not be cleaned with volatile or flammable liquids.

(2) Floors shall be maintained smooth and clean, free of all obstructions and slippery substances. Holes and irregularities in floors shall be repaired to maintain a level surface free from tripping hazards.

(3) All unnecessary materials on walls shall be removed and projections shall be kept to a minimum.

(4) Aisles shall be clearly defined and kept free of hazardous obstructions. Where possible, aisles shall be suitably marked by painting.

(5) All machines, work benches, aisles, etc., shall be adequately illuminated.

(6) Some units that you will disassemble are made up of small parts that can easily be lost, broken, or mixed with other parts. A unit improperly reassembled or one reassembled with defective parts is the starting place for an aircraft accident.

(7) Wornout parts should be disposed of through the proper supply channels and never placed on the floor where they can become dangerous or forgotten.

(8) After servicing equipment with hydraulic fluid from a can, do not attempt to reseal the can. Any hydraulic fluid remaining in a can must be immediately transferred to an approved airtight, pressure venting, stainless steel storage reservoir, an approved hydraulic servicing unit or a hydraulic test stand containing the same hydraulic fluid.

TM 1-1500-204-23-2

(9) Containers of hydraulic fluid which have been accidentally left unsealed shall be considered contaminated and shall be destroyed.

**NOTE**

To avoid contamination, do not use previously opened cans of hydraulic fluid. Cans of hydraulic fluid can not be resealed. Immediately transfer unused hydraulic fluid to an approved airtight, pressure venting, stainless steel storage reservoir, an approved hydraulic servicing unit or a hydraulic test stand containing the same hydraulic fluid. When opening can, clean top and use a clean, sharp, unplated instrument to prevent contamination. Can openers attached to the aircraft must be cleaned before using.

**c. Shop Safety.** Unsafe equipment and fire hazards are the main factors to be observed while planning safety procedures.

**(1) Equipment safety.** Unsafe equipment shall be reported immediately. The following equipment safety practices shall be observed:

(a) Machines shall be located to provide operators with sufficient space to handle materials and perform job operations without interference.

(b) Bolt down all machinery that can move or walk due to vibration (drill press, bench grinder, etc.).

(c) Substantial low resistance conductors shall be used to ground all stationary and portable machines, equipment, or other devices in which static charges may be generated, or which require electrical circuits of a hazardous nature.

(d) Shop machinery shall be operated only by qualified personnel observing safe practices.

(e) Safety devices, such as guards, interlocks, automatic releases, and stops, shall always be kept in operating condition.

(f) Ensure that all unauthorized personnel are clear of area before opening valves or energizing electrical circuits for starting machinery.

(g) Suitable mechanical guards, such as enclosures or barricades, shall be permanently installed on all machinery not already equipped with such to eliminate danger of injury from moving parts.

(h) Machinery shall not be adjusted, repaired, oiled, or cleaned while machine is in operation or power is on.

(i) Personnel operating machinery shall wear protective clothing as prescribed. A protective face shield or goggles shall be worn when operating a grinder regardless of whether grinder is equipped with attached shields.

(j) Jewelry shall not be worn while performing any maintenance.

**(2) Fire Safety.** A constant vigilance must be maintained to seek out fire hazards. Fire hazards are constantly present in the shop where sparks, friction, or careless handling can cause an explosion that may destroy equipment or buildings, and injure or kill personnel. Refer to AR 385-10, The Army Safety Program and the Occupational Safety and Health Act of 1971. The following fire safety practices shall be observed:

(a) NO SMOKING signs shall be placed in areas where smoking could create a fire hazard.

(b) Personnel shall be trained in the use, knowledge, and location of shop fire fighting equipment.

(c) Each shop shall be equipped with fire extinguishers suited for type of fire most likely to occur.

- (d) Use correct fire extinguisher for class of fire as follows:

Class A fire (wood, paper, trash, etc). Use water or soda-acid fire extinguisher.

Class B fire (oil, paint, fuel, grease, etc). Use bromotrifluoromethane or carbon dioxide fire extinguisher.

Class C fire (electrical equipment). Use bromotrifluoromethane or carbon dioxide fire extinguisher.

Class D fire (combustible metals) magnesium, titanium, zirconium, sodium, lithium, and potassium. Use dry powder type fire extinguisher.

(e) Oily waste, rags, and similar combustible materials shall be discarded in self-closing metal containers which shall be emptied daily.

(f) Flammable materials shall not be stored in the shop.

(g) Use only approved cleaning solvents.

**d. Shop Tools and Materials.** Handling tools and materials requires observance of the following common safety practices:

(1) Do not leave tools or objects in elevated positions from which they can fall or be knocked off.

(2) Do not point a compressed airstream toward any part of the body.

(3) All unserviceable tools will be plainly marked and removed from service.

(4) Electrical cables and air hoses to portable units will be laid out so there is no danger of tripping.

(5) Electrical tools must be connected to a low resistance ground.

**3-2. MAINTENANCE OF SHOP EQUIPMENT.** Maintenance of shop equipment consists of cleaning, preventive maintenance, and replacement of defective parts. Preventive maintenance includes before-operation, during-operation, after-operation services performed by operator, and scheduled services to be performed at designated intervals. Consult the operation and service instructions manual for specific maintenance instructions on particular types of equipment.

**a. Hydraulic Filler and Bleeder Unit.** The hydraulic filler and bleeder shown in figure 3-1 is used for servicing and bleeding aircraft hydraulic systems and associated hydraulic equipment. The unit consists of a hydraulic fluid storage tank with an air pressure indicator, air filler and fluid filler valve, and a servicing hose and valve. The following are general instructions for maintenance and service:

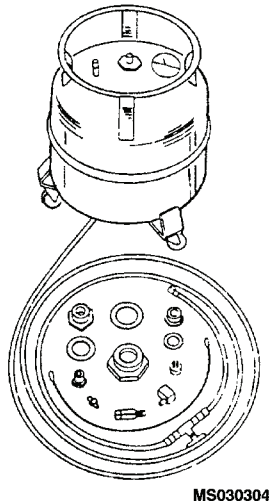
### **WARNING**

Do not attempt to service or perform maintenance on filler and bleeder unit until all air pressure has been released. Failure to comply can result in damage to equipment or personnel.

Do not use any filler and bleeder unit unless it is equipped with a safety relief valve to bleed off excessive air pressure. Failure to comply can result in injury or death.

Degreasing solvent, MIL-PRF-680, is combustible and toxic to eyes, skin and respiratory tract. Wear protective gloves and goggles/face shield. Avoid repeated or prolonged contact. Use only in well ventilated areas (or use approved respirator as determined by local safety/industrial hygiene personnel). Keep away from open flame other sources of ignition.

(1) Clean reservoir and fittings with a cloth moistened in degreasing solvent, MIL-PRF-680, and wipe dry with a clean cloth.



**Figure 3-1. Typical Hydraulic System Filler and Bleeder**

**NOTE**

Calibration of hydraulic gauges is accomplished in the instrument shop which is equipped with hydraulic instruments. Oil preservatives, MIL-H-6083, will be utilized at time of overhaul during depot maintenance as a calibrating medium in lieu of test fluid, MIL-H-5606. Recalibration of flow indicators on test stands will be required if the fluid for which the equipment is calibrated does not conform to the requirements of oil preservatives, MIL-H-6083.

- (2) Remove corrosion, where paint has chipped, by scouring with crocus cloth, Federal Specification P-C-458.
- (3) Touch up areas with original finish paint where corrosion was removed.
- (4) Keep reservoir filled to specified level with hydraulic fluid, MIL-H-5606 or MIL-H-83282 .

**NOTE**

Consult applicable operation and service instructions manual for specific air pressurizing procedures.

- (5) Replace flexible hose connections or manual control valve when leaking.
- (6) Replace defective valve core in valve stem and defective gauge unit with a like serviceable item.
- (7) Replace flexible hose that is frayed, cut, and deteriorated.

**b. Hydraulic Test Stand, Fixed.** This test stand is used for adjusting, flushing, and testing the performance and operating characteristics of hydraulic system components to determine serviceability status.

**WARNING**

Supervisors shall ensure that only qualified personnel operate, service, and maintain hydraulic test equipment. Because of the high pressures involved in testing, proper precautions must be taken to prevent damage or injury to the operator in case of line rupture.

Degreasing solvent, MIL-PRF-680, is combustible and toxic to eyes, skin and respiratory tract. Wear protective gloves and goggles/face shield. Avoid repeated or prolonged contact. Use only in well ventilated areas (or use approved respirator as determined by local safety/industrial hygiene personnel). Keep away from open flame other sources of ignition.

**(1) Cleaning.** Clean test stand by wiping with a cloth moistened in degreasing solvent, MIL-PRF-680, and wiping dry with a clean cloth.

**(2) Daily inspection.** Daily inspection will consist of the following:

- (a)** Visually inspect entire test stand for signs of leaking valves, fittings, and connections.
- (b)** Examine fluid level in reservoir and add hydraulic fluid, MIL-H-6083, as necessary.

**NOTE**

Preservative hydraulic fluid shall be used in all hydraulic test stands permanently installed in the shop.

- (c)** Inspect for worn bearings, packings, or broken seals at drive shafts on pump and motor.
- (d)** Examine test stands for proper operation and correct reading of gauges.

**(3) Periodic inspection.** For frequency and scope of periodic inspection, consult the operation and service instructions manual for specific test stand; however, the following will be used as a general guide:

**(a)** With machine operating under full-load conditions, make a complete visual inspection of test stand to determine if there is any leakage.

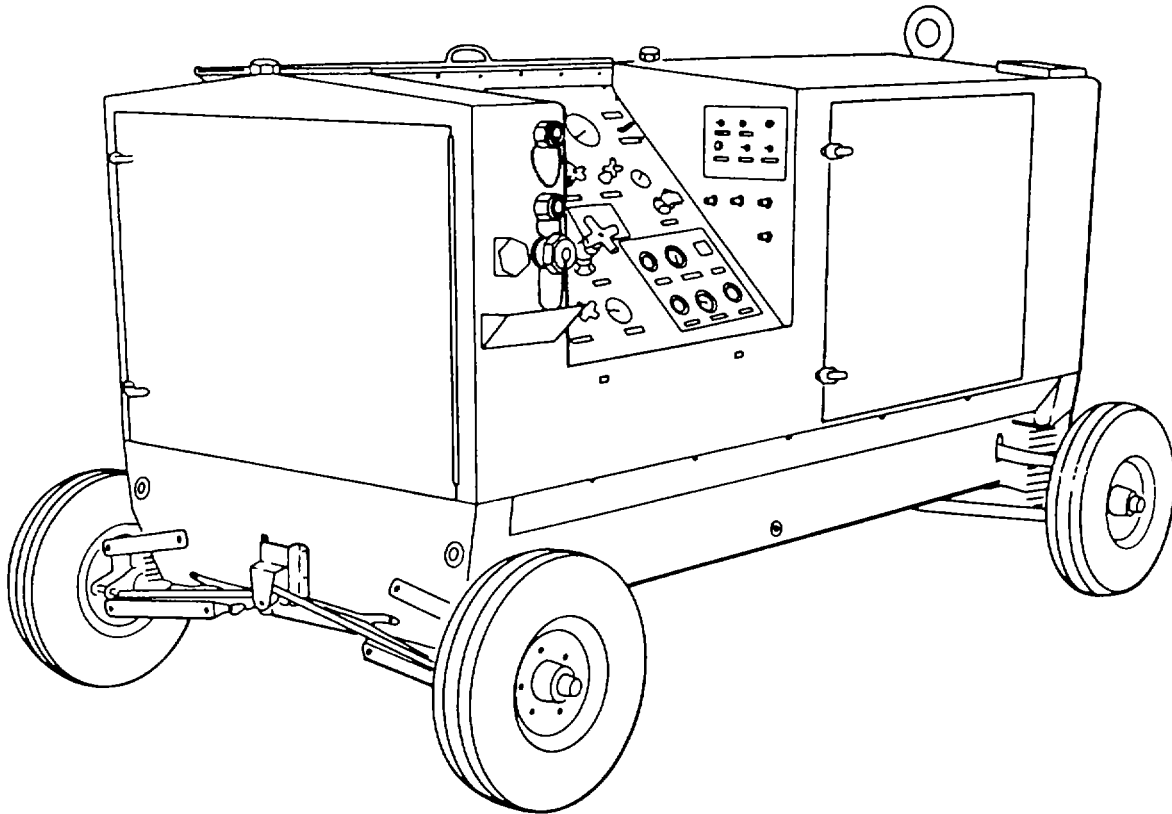
**(b)** Disconnect electrical power and examine all electrical connections in junction box for loose or broken leads.

**(c)** Remove sump cover and clean out any dirt or lint with a clean cloth. Remove sump drain plugs and flush sump with test fluid from machine. Reinstall sump drain plug.

**(d)** Examine filters and replace filter elements in accordance with applicable operation and service instructions manual.

**c. Hydraulic Test Stand, Portable, Gasoline Engine-Driven.** This test stand shown in figure 3-2 is used directly on the aircraft, and simulates the engine-driven hydraulic pump in performing system operational checks, checking system for leaks, and filling or flushing the system.





**Figure 3-2. Typical Gasoline Engine-Driven Hydraulic Test Stand**

(1) *Daily inspection.* When test stand is used daily, the following inspections are required. Otherwise, daily inspections shall be observed each time test stand is put into use.

- (a) Examine fluid level in hydraulic reservoir and refill as required with hydraulic fluid, MIL-H-5606 or MIL-H-83282
- (b) Inspect tires on trailer assembly for specified inflation.
- (c) Examine interior of housing and cabinet for broken wiring, worn insulation, and loose connections. Examine all tubing for loose fittings and leakage.
- (d) Ensure that all controls move freely and that control handles are secure on control and instrument panel. Ensure that all instrument glasses are intact and not broken.
- (e) Examine fuel level in fuel tank, and refill as required with gasoline, MIL-G-5572, Grade 80/87. Examine fuel filter for contamination and sediment bowl for dirt or water.
- (f) Examine oil level in engine crankcase and gearbox transmission. Add oil as required.
- (g) Examine electrolyte level in batteries, adding distilled water as required. Ensure that battery cables are securely fastened, and top of battery is clean.

(h) Prior to first use of test stand, examine pressure gauge to determine that maximum hydraulic pressure is obtainable, and inspect for high pressure leaks.

(2) *Periodic inspection.* For frequency and scope of periodic inspection, consult the operation and service instructions manual for the specific test stand; however, the following will be used as a general guide.

(a) Visually inspect interior of hydraulic reservoir for possible accumulation of sludge. Inspect and replace reservoir vent filter when necessary.

(b) Examine tire treads on trailer assembly for uneven wear. Rotate tires when necessary

(c) Carefully inspect housing and cabinet assembly for loose screws, bolts, and nuts. Tighten as required.

(d) Inspect fuel system for loose fittings that may cause fuel leakage. Examine and replace fuel filter as necessary.

(e) Examine oil level in engine crankcase and gearbox transmission, and add oil as required. Replace engine oil filter. Examine oil-bath type air cleaner and service as necessary.

(f) Remove and examine spark plugs, and clean with spark plug cleaner. Discard all unserviceable spark plugs.

(g) Inspect battery cell electrolyte with a hydrometer. A specific gravity reading of 1.150 or less indicates a low battery charge.

**NOTE**

When test stand is out of operation for lengthy, intermittent periods, batteries should be tested more frequently, or placed on trickle charge in battery charge.

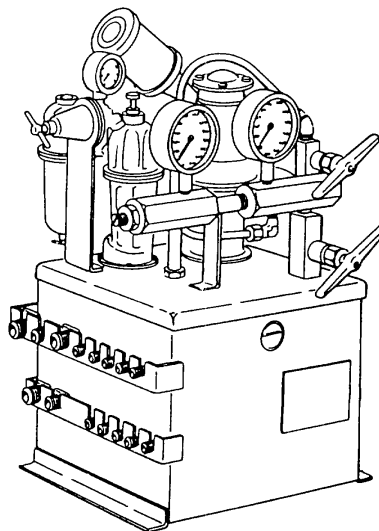
(h) Examine engine ignition timing, magneto point condition, and gap.

(3) *Lubrication.* Consult applicable operation and service instructions manual of particular hydraulic test stand for type of lubricant, time of application, amount and point of lubrication.

d. *Hydraulic Hose Testing Unit.* The hose testing units commonly used are designed to provide hydraulic pressure to 15,000 psi for proof pressure and leakage tests on aircraft hose assemblies. See figure 3-3 for a typical unit. Prior to use the operator should:

(1) Examine fluid level in the reservoir. Add hydraulic fluid, MIL-H-6083, as required.

(2) Inspect entire unit for loose connections, defective lines, or fittings. Tighten or replace as required.



**Figure 3-3. Typical Hydraulic Hose Testing Unit**



**e. Tube-Bending Machine, Hand-Operated.** The tube-bending machine shown in figure 3-4 is used for portable bending of various sizes of hydraulic rigid tubing.

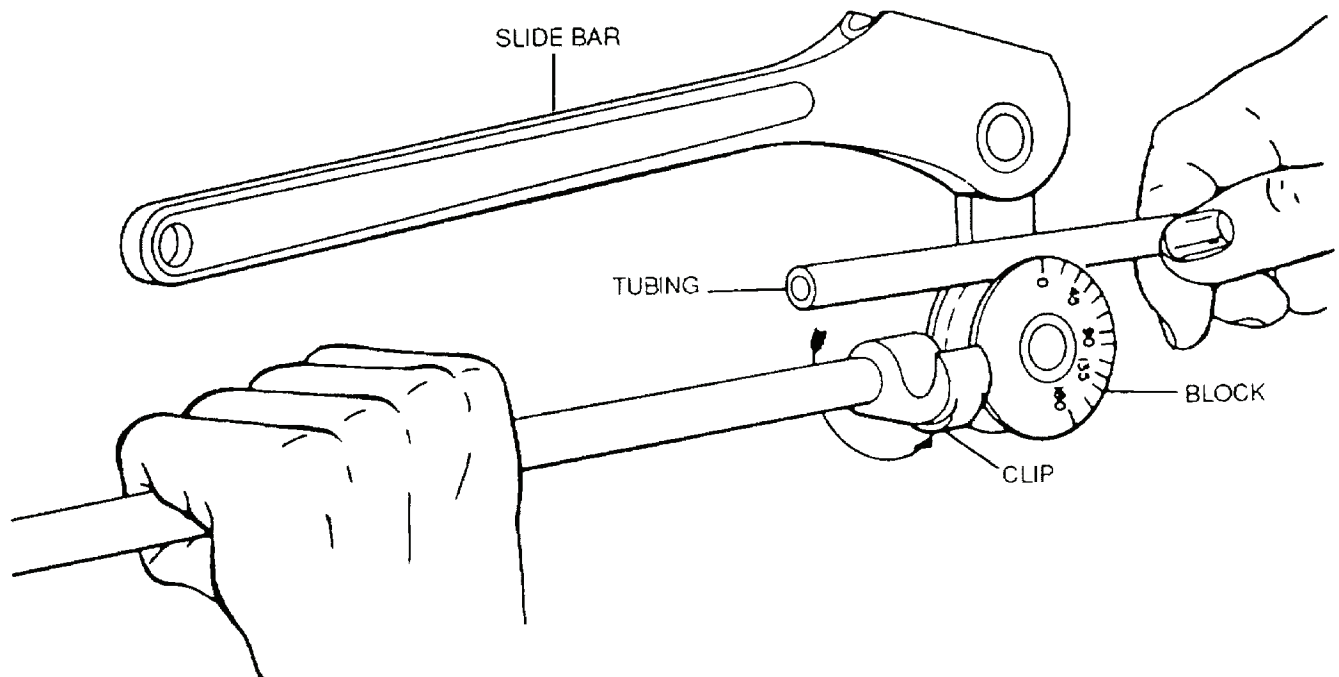
**WARNING**

Degreasing solvent, MIL-PRF-680, is combustible and toxic to eyes, skin and respiratory tract. Wear protective gloves and goggles/face shield. Avoid repeated or prolonged contact. Use only in well ventilated areas (or use approved respirator as determined by local safety industrial hygiene personnel). Keep away from open flame other sources of ignition.

**(1) Cleaning.** Keep tube-bending machine free from grease and dirt by cleaning with a cloth moistened in degreasing solvent, MIL-PRF-680, and wiping dry with a clean cloth.

**(a) Corrosion prevention.** After cleaning, to prevent tube-bending machine and accessories from rusting, apply a light coat of oil, MIL-L-7870, to surfaces.

**(b) Corrosion removal.** When rust spots are present, they may be removed by scouring with crocus cloth, Federal Specification P-C-458. Touch up with the original finish.



MS030307

Figure 3-4. Tube Bending Machine

TM 1-1500-204-23-2

(2) **Periodic inspection.** For frequency and scope of periodic inspection, consult operation and service instructions manual for specific bending machine; however, the following shall be used as a general guide:

(a) Visually inspect tube-bending machine for cracks, loose bolts and nuts, mounts for security, and defective or damaged parts.

(b) Lubricate tube-bending machine as required.

f. **Master Gauge Unit.** This unit consists of a pressure gauge, a manual control valve, and length of flexible hose with connecting fittings. A typical unit is shown in figure 3-5.

(1) Replace flexible hose when it becomes frayed, cut, or deteriorated.

(2) Replace gauge or control valve when found to be defective.

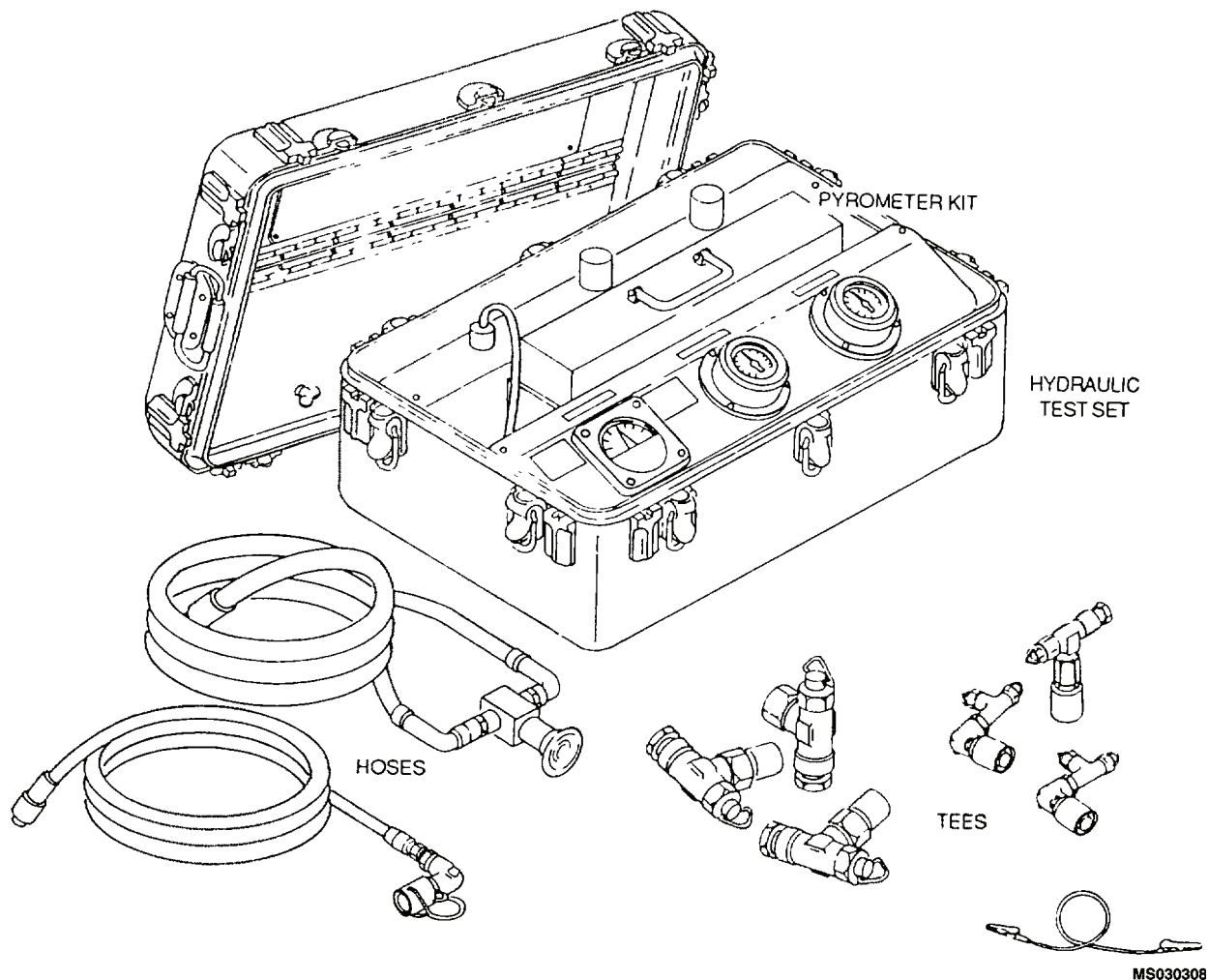


Figure 3-5. Typical Master Gauge Unit

g. Hydraulic Fluid Dispenser, Aircraft, AF-5, NSN 4930-00-245-1832.

(1) Model AF-5 Hydraulic Fluid dispenser contains a buna N and nylon cord bladder in which air pressure is maintained in order to eject oil from the machine. This special bladder is approximately the same size as the tank and when filled with air approximately fills the tank's volume.

(2) The purpose of the bladder is to separate the hydraulic fluid in the tank from the compressed air used to expel fluid into a hydraulic system, thereby insuring that no air or condensation will contaminate the hydraulic fluid or brake system.

(3) This type of construction requires special procedure in filling dispenser and charging it with compressed air.

(4) To fill the dispenser

(a) Close the valve at the outer end of the hose.

(b) Open the bleeder valve located under the pressure gauge. Do not tamper with the pressure relief valve. This bleeder valve drains air cavity.

(c) To deflate the bladder completely, put no more than 10 psi of air pressure into the fluid cavity of the tank through the air valve located in the filler cap. This will reduce the size of the bladder to allow maximum oil capacity in the tank.

(d) When all air stops coming from the bladder bleeder valve, thus indicating that the bladder is flat, close the bleeder valve.

(e) Release the air pressure in the oil cavity of the tank by pressing the red tank air drain button. When pressure gauge reads zero and no further air flows from the button valve, remove the filler cap.

(f) Pour up to 5 gallons of hydraulic fluid into the tank. Replace filler cap and tighten with wrench.

(g) Inflate bladder through the air valve located under the pressure gauge to 10 psi.

(h) Bleed all trapped air from the fluid cavity by pressing the red button valve and holding it until a clear stream of hydraulic oil ejects.

(i) Inflate bladder through air valve under pressure gauge until the pressure relief valve pops. Do not exceed 50 psi.

(j) Recharge the bladder as required. If 3-1/2 to 4 gallons of oil used to charge the tank, a sufficient air cavity will be left to expel the liquid charge with a single air charge.

(k) Stencil the dispenser to show the specification number of the fluid that it contains.

(l) The discharge nozzle end of the dispensing line shall be wiped clean prior to and after each use, and protected from contamination by a small amount of plastic food wrap and rubber band.

**3-3. HANDLING OF HYDRAULIC FLUID IN 55-GALLON DRUMS.** Correct storage and handling of hydraulic fluid is critical to ensure a supply of uncontaminated fluid for aircraft servicing.

**a. Storage.** Store 55-gallon drums horizontally with the closures at the 9 o'clock and 3 o'clock positions. This prevents contaminating material from collecting around the top of the drum and around the closures. The drums should be placed in covered storage either under a roof or covered by a plastic sheet or tarpaulin.

**b. Cleaning.** Prior to use or prior to standing the drum on end, the top of the drum should be thoroughly brushed with a stiff brush to remove all gross contaminating material. The top and particularly the closures should then be wiped with lintless rags saturated with hydraulic fluid MIL-H-5606, MIL-H-6083 or MIL-H-83282.

**c. Withdrawing Fluid from Drum.** Fluid can be withdrawn from the drum using the following methods:

**CAUTION**

Use an apron, goggles, protective glasses, and protective gloves when working with solvents or hydraulic fluid as fluid can be absorbed into the skin.

**(1) Faucet.** If small quantities of hydraulic fluid are to be used, a faucet may be installed in the 3/4-inch closure for use while the drum is in a horizontal position. The faucet must be thoroughly wiped with hydraulic fluid prior to use. Fluid should be permitted to flow for a short period to flush any contamination that may have accumulated in the faucet.

**CAUTION**

Prior to inserting pump in drum, the drum must be cleaned as per paragraph 3-3 b. Prior to drawing off hydraulic fluid to be used in aircraft, a small amount of fluid must be flushed through the pump. Failure to comply may result in contamination of fluid, rendering it useless.

**WARNING**

MIL-PRF-87937, Type II cleaning compounds can irritate eyes and skin. Wear protective gloves and goggles. Avoid repeated or prolonged contact.

**(2) Pumps.** If large quantities of hydraulic fluid are needed, the following new, thoroughly cleaned, hand-operated pumps may be used. (See Chapter 1, Part 1, FM 10-69).

TM 1-1500-204-23-2

**WARNING**

Never siphon by mouth. Ingestion of hydraulic fluid can cause sickness or be fatal.

**NOTE**

It is necessary to clean even new pumps to prevent contamination of hydraulic fluid. Cleaning may be accomplished by pumping approximately 1 gallon of cleaning compound MIL-PRF-87937 through the pump. After draining the cleaning solvent completely, pump approximately 5 gallons of the appropriate hydraulic fluid through the pump. Thoroughly clean and wipe the portions of the pump to be installed in the 55-gallon drum with clean, lint-free rags saturated with the appropriate hydraulic fluid, before installing the pump in the drum.

Dispensing pump, hand-driven, piston-type, self-measuring type, 1-quart-per-stroke.

12 GPM, hand-driven dispensing pump (100 cycles per minute).

15 GPM, piston-type, hand-driven dispensing pump with 20-foot hose (22 gallons per 100 revolutions).

**(3) Nozzles.** The discharge nozzle end of the dispensing line shall be wiped clean prior to and after each use, and protected with a small piece of plastic food wrap and rubber band. This procedure will eliminate contamination from entering the nozzle.

**d. Transporting Fluid to Aircraft.** Hydraulic fluid may be transported from bulk storage to the aircraft in an approved hydraulic servicing unit.

## CHAPTER 4

### HYDRAULIC MAINTENANCE PRACTICES

**4-1. General.** This chapter provides general instructions for maintenance of aircraft hydraulic systems, the materials required, and methods to be used. A systematic application of the basic information in this chapter will result in more efficient maintenance practices. In those cases where specific instructions for a particular aircraft are required, refer to the applicable aircraft maintenance manual. Materials and processes recommended are identified by military or federal specification number or by manufacturer.

**4-2. Tubing Systems and Repairs.** Tubing used in aircraft hydraulic systems carries pressure to distant points in the aircraft to provide control of various critical components. Failure of this tubing will result in pressure loss and subsequent loss of control, resulting in possible destruction to aircraft and injury or death.

a. *Types.* Corrosion-resistant steel tubing and aluminum alloy tubing are used in aircraft for fuel, oil, coolant, oxygen, instrument, hydraulic, and vent lines, as well as for electrical conduits and ventilating ducts. Copper tubing generally has been superseded as a general purpose tubing by aluminum alloy tubing because of its lighter weight, ease of forming, and resistance to corrosion and fatigue. Tubing material can be identified by visual inspection or by the aluminum alloy designation stamped on the surface.

(1) *Corrosion-resistant steel tubing.* Corrosion-resistant steel tubing, MIL-T-8504 and MIL-T-6845, is used in high pressure hydraulic systems (3000 psi) such as landing gear, wing flaps, and brakes. External brake lines should always be made of steel to prevent damage caused by flying gravel and stones and ground handling accidents. On hydraulic systems using 1/2-inch corrosion-resistant tubing or larger, aluminum alloy nuts and sleeves may be used. Steel nuts and sleeves should be used on 3/8 inch corrosion resistant tubing or smaller. Corrosion-resistant steel tubing does not have to be annealed for flaring or forming. The flared section is somewhat strengthened by cold working and consequent strain hardening. The high tensile strength of corrosion-resistant steel tubing permits use of thinner walls than those of aluminum alloy tubing, but the weight is about the same as thick-walled aluminum alloy tubing.

(2) *Aluminum alloy tubing.* Aluminum alloy tubing, Federal Specification WW-T-700/1, is used for general purpose lines and conduits of low fluid pressure, such as instrument lines, and electrical and ventilating conduits. Aluminum alloy tubing Federal Specifications

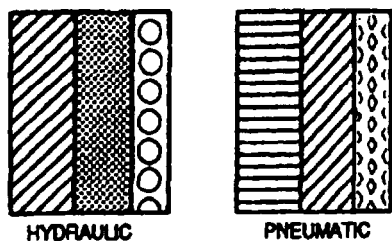
WW-T-700/4 and WW-T-700/6, is the most widely used tubing for general purpose lines of low and medium pressures. It is easily flared, and is soft enough to be formed with handtools. It should be handled with care to prevent scratches, dents, and nicks. Aluminum alloy tubing is used with either of two types of connections; flared joint for mechanical connections, or beaded end for use with clamps and flexible hose connections. In hydraulic systems, 5052-0 aluminum alloy tubing, Federal Specification WW-T-700/4, is used for reduced pressure (1500 psi maximum) and return lines. Aluminum alloy tubing 6061 and 6062 MIL-T-7081, may be used for high pressure lines (3000 psi). Use of MIL-T-7081 tubing in aircraft is limited by MIL-H-5440. Tubing conforming to Federal Specifications WW-T-700/1 and WW-T-700/6 shall not be used in hydraulic systems.

(3) *Copper tubing.* High pressure oxygen systems use 3/16-inch diameter, 0.032-inch wall thickness copper tubing, Federal Specification WW-T-799, Type N. Fittings are silver soldered onto the tubing in accordance with MIL-B-7883, before tubing is installed.

(4) *Rigid Tubing.* The tubing used to produce rigid tubing assemblies is sized by its outside diameter (OD) and wall thickness. Outside diameter sizes are in sixteenth-of-an-inch increments, the number of the tube indicating its size in sixteenths of an inch. For example, the number 6 tubing is 6/16 or 3/8 inch, number 8 tubing is 8/16 or 1/2 inch, and so forth. Wall thickness is specified in thousandths of an inch. Most aircraft maintenance manuals contain a table which lists the original material and acceptable substitutes and gives the wall thickness for each.

b. *Tubing Identification.* The Army uses two types of identification systems to code hydraulic plumbing lines of aircraft. The two systems used are the printed-symbolized tape system (see figure 4-1), the preferred method, and the solidcolor band (see figure 4-2), the alternate method. This identification will be applied in accordance with TM 1-1500-204-23-1) paragraph 6-3.

c. *Tubing Damage.* Damage such as nicking and scratching of tubing can be minimized by using care. Most damage of this kind occurs from careless handling of tools during maintenance of aircraft. Any dent less than 20 percent of tubing diameter is not objectionable unless it is on the heel of a short bend radius. A nick no deeper than 15 percent of wall thickness of aluminum, aluminum alloy, copper, or steel, and is not in the heel of the bend, may be reworked by



**LEGEND**




-  BLUE-ANA BULLETIN 166 CODE NO. 501
-  YELLOW-ANA BULLETIN 166 CODE NO. 505
-  INTERNATIONAL ORANGE-ANA BULLETIN 166 CODE NO. 508

Figure 4-1. Printed - Symbol identification Tape.

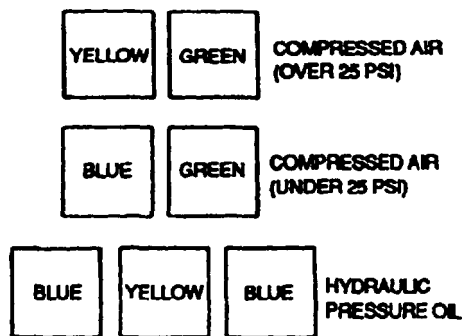


Figure 4-2. Solid Color Band Identification.

d. Cutting Tubing. To ensure a good flared tubing connection, tubing should be cut squarely, and the end deburred before it is flared (see figure 4-3). The standard tubing cutter is clamped over tubing and rotated toward its open side as cutting wheel is gradually fed into tube by turning thumbscrew. The cutting wheel should be fed into the tube only while the cutter is being rotated, as dents will be caused in tubing if the cutter is not moving. Moderate or light tension on thumbscrew will prevent bending and excessive burrs on tubing. If a cutter is not available, a hacksaw blade with 32 teeth per inch can be used.

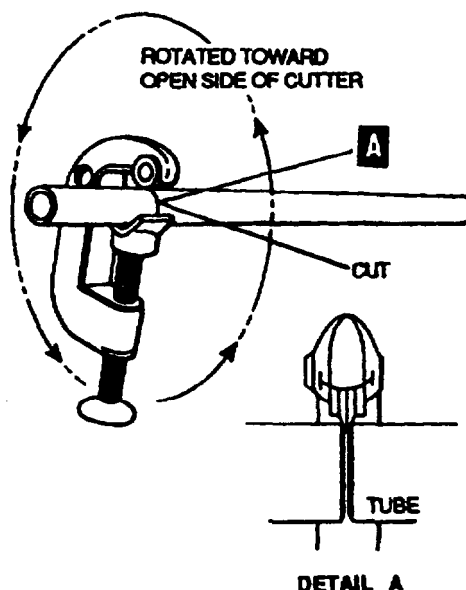


Figure 4-3. Cutting Tube with Tube Cutter.

burnishing with hand tools. Nicked tubing is not only weaker as to internal pressure, but such nicks must be burnished out to reduce a notch effect. If nicks are not burnished out, concentration under vibration will cause weakening and breaking at nicked point. Burnishing removes notches by removal of surrounding material. Burnishing is not allowed in the heel of bends where material has already been stretched thin during forming. Where tubing is used for fluid's (liquid or gaseous) at atmospheric pressure or less, bursting strength of tubing is unimportant and, therefore, dents and nicks may be disregarded providing that the tubing is structurally sound for its specific application, internally unobstructed, and that it remains leaktight at all times. Dents can be removed from tubing by drawing a bullet through tubing. The diameter of the bullet must be equal to or slightly less than the inside diameter of the tubing.

e. Bending Tubing. Tubing may be bent with any one of a variety of bending tools. The hand bending tool is shown in figure 4-4. Bending in a smaller radius than limits shown in table 4-1, or forming flattened, kinked, or wrinkled bends should be avoided (see figure 4-5). MIL-T-7081-6061T-6 aluminum tubing may be formed through tubing processes by maintaining a 1-inch bend radius for 1/4-inch and 3/8-inch tubing. All sizes above 3/8 inch will require the use of a mandrel to form. Bends in 5/16 inch outside diameter oxygen tubing should

have a radius for 1/4-inch and 3/8-inch tubing. All sizes above 3/8 inch will require the use of a mandrel to form. Bends in 5/16 inch outside diameter oxygen tubing should have a radius or curvature of at least 11/16 inch. Tubing may be bent without the aid of tools by carefully forming desired radius by hand; however, this method is crude and should be used only in absence of proper tools. Aluminum alloy tubing used in oxygen systems should not be hand bent. Tubing 1/2 inch outside diameter or larger should be packed with fusible alloy, Federal Specification QQ-F-838, to prevent cracked or wrinkled bends. When bending tubing, a large radius should be formed and gradually worked down to desired radius.

### **CAUTION**

A torch or flame should never be applied to tubing or fusible alloy, as excessive heat will destroy both strength of heat-treated tubing and melting characteristics of fusible alloy. Boiling water will not melt fusible alloy after a flame has been applied.

(1) *Use of fusible alloy for bending tubing.* A bending machine should be used when bending aluminum or duralumin tubing. Before bending, most aluminum alloy tubing is in annealed condition, and should be packed with fusible alloy, Federal Specification QQ-F-838. One end of tube to be bent is closed to prevent leakage of fusible alloy. Tubing and ladle containing fusible alloy is immersed in a tank of boiling water until alloy is melted. Melting point of the fusible alloy is 160 degrees (71 degrees C). For ordinary tubing lengths, a hot water tank similar to that used in plating shops may be used. For longer lengths, a special tank may be constructed, or a length of pipe used so that both tubing and ladle will be completely submerged. When fusible alloy has melted, it is poured into tubing. Both tubing and ladle are kept beneath surface of hot water during pouring operation so that molten alloy will displace water in tubing. Remove tubing from hot water and cool with cold water or allow to air cool until fusible alloy is solidified. Tubing can then be bent with a bending machine or form blocks. Fusible alloy should be cold when bending tubing, and tubing should be bent slowly. When bending operation is completed, fusible alloy may be removed from tubing by immersing both tubing and ladle in tank of hot water and pouring alloy back into ladle. When pouring alloy back into ladle, both tubing and ladle should be kept beneath surface of hot water, as this reduces tendency of alloy to stick to inside of tubing.

(2) *Tube flattening.* In some cases, a certain amount of flattening may occur when bending tubing regardless of procedure used, especially on thin-walled tubing bent to minimum bend radii. As tube flattens, it assumes the shape of an ellipse in cross section, and the area is reduced. This restriction either reduces amount of fluid actually delivered, or requires additional pumping power to overcome increased line friction. When tube is flattened so that minor axis of ellipse is 75 percent of normal tube diameter, area is reduced to 90 percent of original. Further flattening of tube may be considered as cause for rejection.

(3) *Tube bend data drawing.* Tube bend data shall be prepared on A size drawings in accordance with format shown in figure 4-6. Local forms for tube bend data are no longer acceptable. Points of possible confusion are explained in the following paragraphs.

(a) *Distance from Y end.* DISTANCE FROM Y END column shows the measured distance from the Y end to the first bend, the measured distance from Y end to the second bend, etc. This distance can be measured either by making all measurements before any bending takes place, or by utilizing scale on the bending machine.

(b) *Dial setting.* DIAL SETTING column shows degree of bend from the horizontal reference plane. This column is based on a 360-degree graduated dial for the bending machine. Where a dial is graduated in 180 degrees, right and left indications are used, and it is necessary to compute necessary setting for settings more than 180 degrees. This calculation consists of subtracting the dial setting shown from 360 degrees. Result will be proper setting for left side of dial. Dial settings less than 180 degrees are identified for both types of dials. For continuity of operation, dial settings are based on continual clockwise rotation of dial.

### **NOTE**

Example: For a desired dial setting of 286 degrees, the reading on a 360-degree dial is 286 degrees. To determine the reading on a 180 degree dial for a dial setting of 286 degrees, subtract 286 degrees from 360 degrees. The difference (74 degrees) is the reading as read on the left side of the dial.



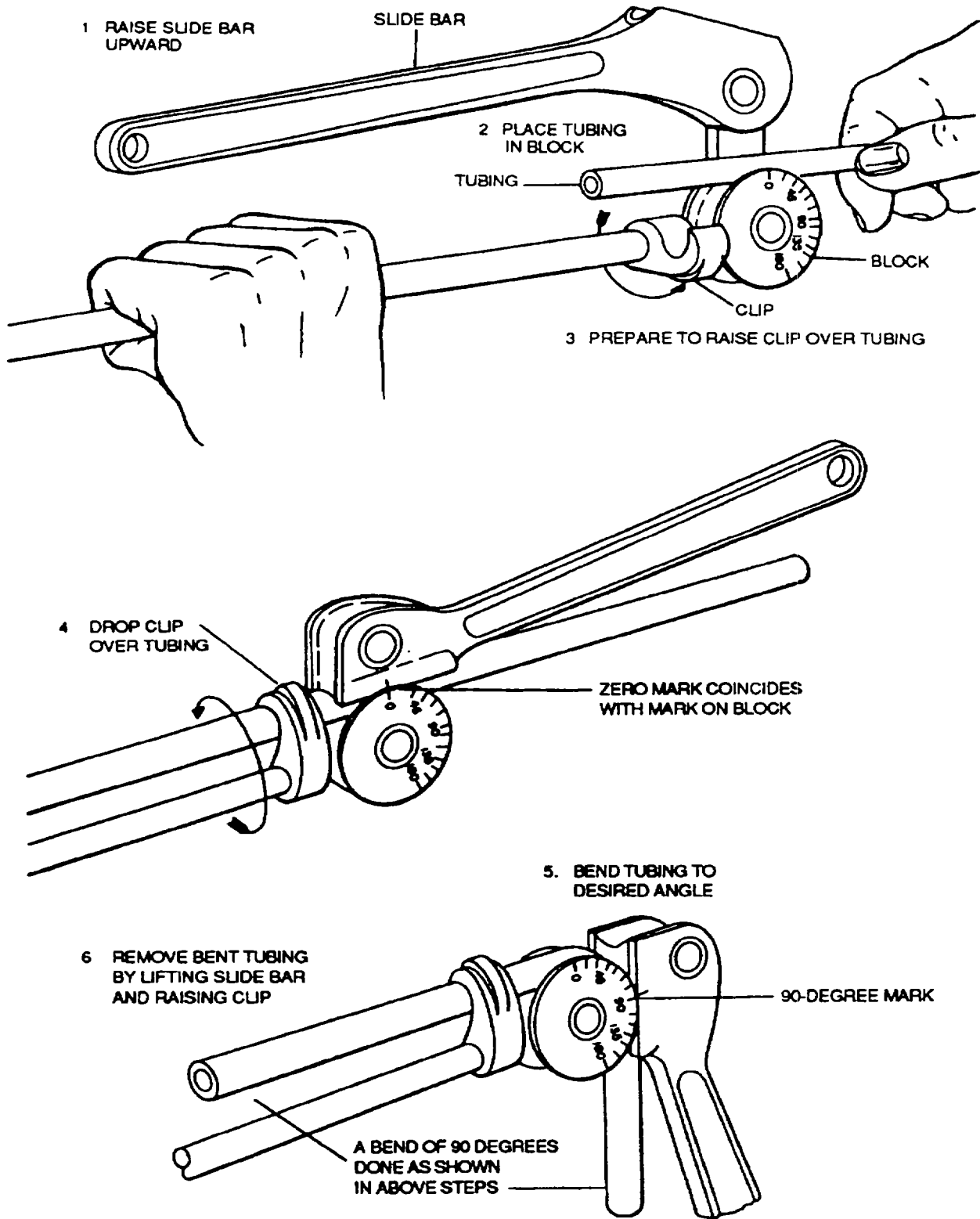


Figure 4-4. Bending Tube with Bending Machine

**Table 4-1. Bend Radii for Conduit and Fluid Lines<sup>1</sup>**

Nominal tube OD (inches)	Minimum bend radii <sup>2</sup>		Steel tubing	
	1100-1/2H, 5052-O (inches)	Corrosion resistant <sup>3</sup> (inches)	Desirable radius (inches)	Minimum radius <sup>4</sup> (inches)
1/8	3/8	—	—	—
3/16	7/16	21/32	3/4	3/8
1/4	9/16	7/8	1	3/8
5/16	11/16	—	1 1/4	3/8
3/8	15/16	1 5/16	1 1/2	3/8
1/2	1 1/4	1 3/4	2	1/2
5/8	1 1/2	2 3/16	2 1/2	5/8
3/4	1 3/4	2 5/8	3	3/4
7/8	2	—	3 1/2	7/8
1	3	3 1/2	4	1
1 1/8	3 1/2	—	4 1/2	1 1/4
1 1/4	3 3/4	4 3/8	5	1 1/2
1 3/8	4 1/4	—	5 1/2	1 3/4
1 1/2	5	5 1/4	6	2 1/8
1 5/8	6	—	6 1/2	2 1/2
1 3/4	7	6 1/8	7	2 7/8
1 7/8	7 1/2	—	7 1/2	3 1/4
2	8	7	8	3 5/8

<sup>1</sup> Bend radii measured to inside of bend.

<sup>2</sup> Increase bend radii when wall thickness is below standard.

<sup>3</sup> Equal to 3-1/2 times tube diameter.

<sup>4</sup> The minimum radius will be used only when the desirable radius cannot be used.

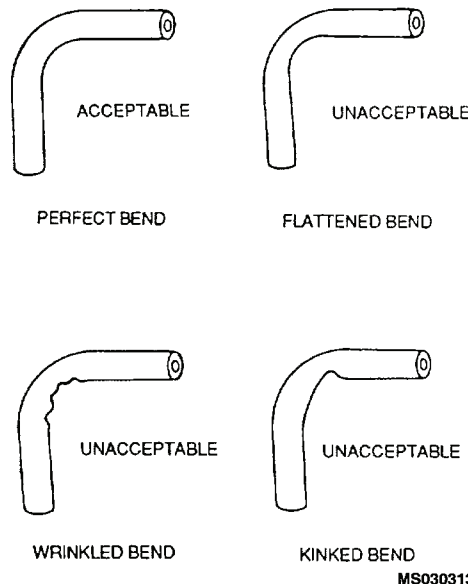
**(c) Distance B.** Distance B is the distance from the last bend to the end of the tube. This measurement may be made with original measurements, but should be rechecked after final bending operation.

**f. Flaring Tubing.** As system pressures increase, tubing joints must be designed so as not to be adversely affected by increasing pressures. Single flared tubing is used for tubing joints on all sizes of steel tubing, 6061 aluminum alloy tubing, MIL-T-7081, and all sizes of 5052 aluminum alloy tubing, Federal Specification WW-T-700/4, above 1/2-inch OD. Double flared tubing is used for tubing joints on all sizes of 5052 aluminum alloy having an OD of 1/2 inch or less. Double flaring reduces cutting of flare by overtightening and failure of tube assembly under operating pressure. See figures 4-7 and 4-8 for tube dimensions.

**WARNING**

Denatured alcohol is flammable and toxic to eyes skin and respiratory tract. Wear chemical protective gloves and goggles/face shield. Avoid repeated or prolonged contact. Use only in well ventilated areas. If ventilation is not adequate, use approved respirator as determined by local safety/industrial hygiene personnel. Keep away from open flames, welding or other sources of ignition.

**(1) Preparing flaring tool for flaring.** Before using flaring tool, clamping surfaces should be free from oil, grease, or aluminum particles. Clamping surfaces may be cleaned with naphtha, Federal Specification TT-N-95, or anhydrous ethyl alcohol, Federal Specification O-E-760, Class A, and a stiff fiber brush. Do not use a wire brush or steel wool. If tubing slips in the tool during the flaring operation and the cleaning procedure does not work, clamping blocks should be dipped in a 20 percent solution, by weight, of sodium hydroxide, Military Standard MS36037, or potassium hydroxide, Military Standard MS36035, in water. This will remove the aluminum alloy particles. The inner surface of clamping blocks should never be sandpapered, ground, or refinished, as this will render the tool unsatisfactory for use.



**Figure 4-5. Acceptable and Unacceptable Tubing Bends**

**(2) Preparing tubing end for flaring.** The tubing end is prepared using the following procedures (see figure 4-9):

- (a)** File end of tubing square with fine flat file.
- (b)** Remove burrs from inside and outside of tubing with burring tool.
- (c)** Remove all filings, chips, and grit from inside of tube.

(d) Clean tubing.

(e) Inspect tubing end to see if it is round, cut square, clean, and free from draw marks and scratches. Draw marks and scratches are likely to spread and split tubing when it is flared.

**(3) Flaring tool.** The flaring tool shown in figure 4-10 is suitable for producing tubing flares having a 74-degree included angle. It will produce a double lap flare, conforming to Military Standard MS33583, on 3/16-inch through 3/4-inch mild aluminum tubing, and a single lap flare, conforming to Military Standard MS 33584, on all grades of aircraft tubing including 1/8-inch through 3/4-inch, 1/4-hard, corrosion-resistant steel. Correct use of the flare tool will give a perfect flare. Incorrect double flares, as shown in figure 4-11, should be cut off and another flare made. A short inner flare should not be used because of short bearing surface for the fitting nipple. The short inner flare is caused by inserting tubing too low in clamp blocks or by tubing slipping during flaring operation. Improper tightening, jamming of tightening screw, or dirt on inner surface of clamp blocks will cause tubing to slip. A long inner flare should not be used because it will restrict fluid flow. The long inner flare is caused by improper gauging.





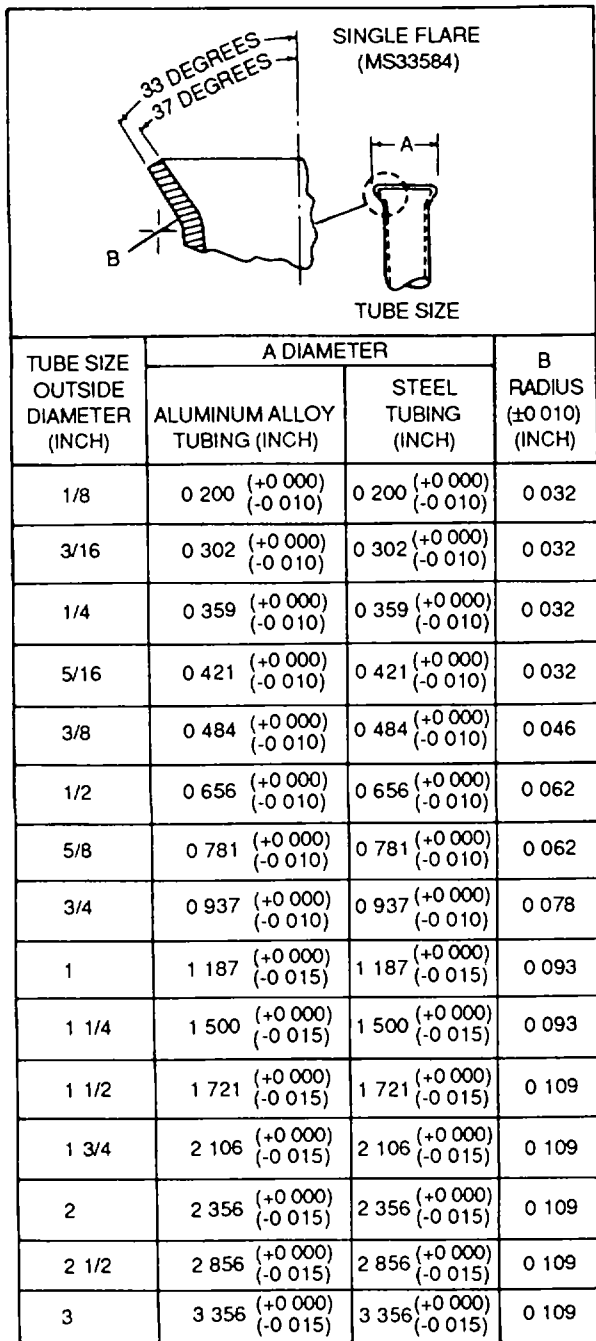


Figure 4-7. Dimensions for Single-Flared Tubing

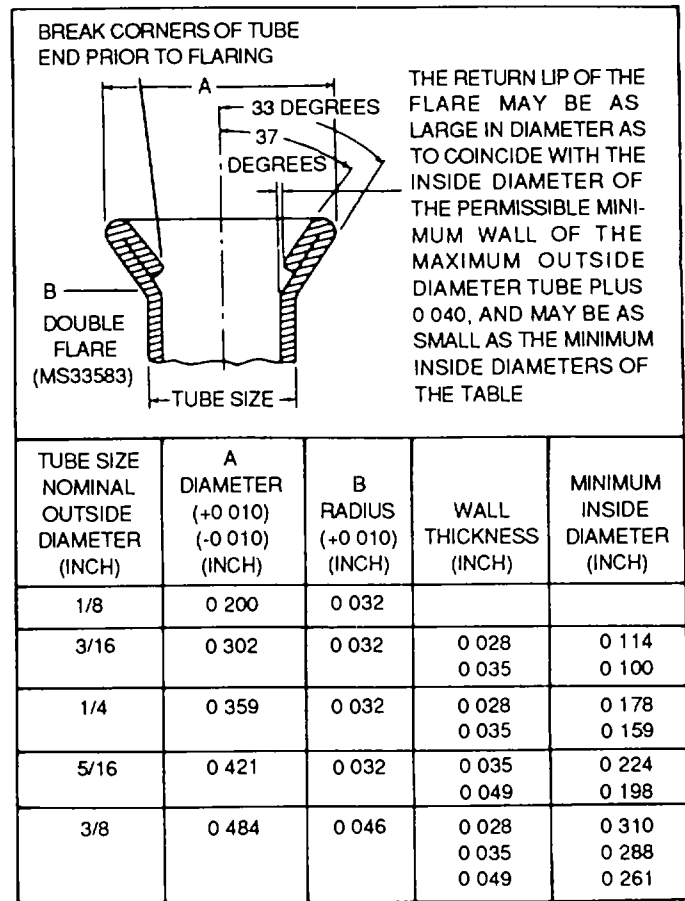


Figure 4-8. Dimensions for Double-Flared Tubing

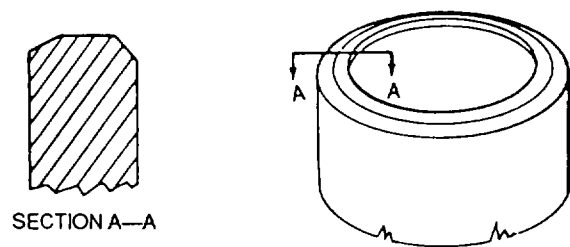
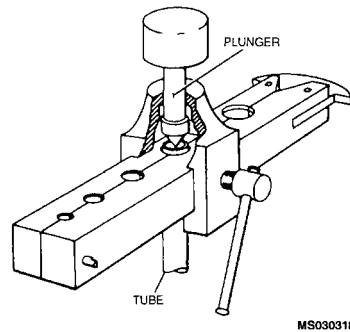


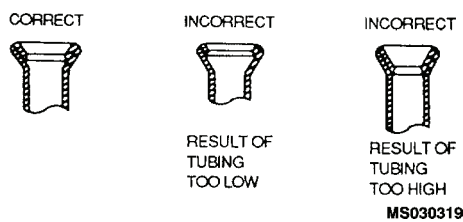
Figure 4-9. Properly Burred Tube

**NOTE**

Tubing should be flared by the single flare method only in an emergency when a double flare tool is not available.



**Figure 4-10. Flaring Tool**



**Figure 4-11. Tubing with Double Lap Flare**

**g. Cleaning Tubing.** After tubing is bent and ends are flared, it will thoroughly cleaned prior to installation in the aircraft.

**WARNING**

Degreasing solvent, MIL-PRF-680, is combustible and toxic to eyes, skin and respiratory tract. Wear protective gloves and goggles/face shield. Avoid repeated or prolonged contact. Use only in well ventilated areas (or use approved respirator as determined by local safety/industrial hygiene personnel). Keep away from open flame other sources of ignition.

Compressed air shall not be used for cleaning purposes unless reduced to less than 30 psi and then only with effective chip-guarding and personal protective equipment.

**CAUTION**

To avoid oil base contamination, clean oxygen tubing and fittings in accordance with paragraph 4-2g(2).

**NOTE**

Store solvent in nonflammable storage cabinet when not in use.

**(1) Cleaning process.** Clean tubing with suitable solvent to remove dirt, grit, or other foreign matter. Always check the applicable technical manual (TM) for any special procedures for cleaning and testing. If no particular type of solvent is specified in the applicable TM, use degreasing solvent, MIL-PRF-680, Type II, for petroleum and synthetic-base fluid lines. The part will be soaked and washed thoroughly in the solvent. All parts must be completely dry before being assembled or installed. Use compressed dry, filtered air to dry parts. Keep solvent in a tightly sealed container. When using solvent indoors, be sure that the work area is well-ventilated.

**(2) Cleaning oxygen system tubing.** All oil and grease will be removed from oxygen tubing and fittings using one of the following methods.



**WARNING**

HFE-71DE is toxic to eyes, skin and respiratory tract and decomposes into other hazardous products when exposed to extreme heat. Wear chemical protective gloves and goggles/face shield. Avoid repeated or prolonged contact. Use only in well ventilated areas. If ventilation is not adequate, use approved respirator as determined by local safety/industrial hygiene personnel. Keep away from open flames, welding or other sources of ignition.

n-Propyl Bromide is toxic to eyes, skin, and respiratory tract. Wear protective gloves and goggles/face shield. Avoid repeated or prolonged contact. Use only in areas with adequate mechanical or local exhaust ventilation (or use approved respirator as determined by local safety/industrial hygiene personnel).

**(a) Method A.** A vapor degreasing method with stabilized n-propyl bromide or HFE-71 shall be used. Proper cleaning is assured by allowing tubing and fittings to remain in vapor degreaser until operating temperature is obtained. Tubing is blown clean and dried with a stream of clean, dry, water-pumped air. Every precaution, including sniffing the tubing, should be taken to determine whether tubing and fittings are clean. Oil-pumped air should be used as a substitute for water-pumped air, because oil would be deposited in tubing. Oxygen, Federal Specification BB-O-925, or clean, dry, water-pumped nitrogen, Federal Specification BB-N-411, may be used in place of water-pumped air.

**WARNING**

Aliphatic Naphtha is extremely flammable and toxic to eyes, skin and respiratory tract. Wear protective gloves and goggles/shield. Avoid repeated or prolonged contact. Use only in well ventilated areas (or use approved respirator as determined by local safety/industrial hygiene personnel). Keep away from open flame other sources of ignition.

Denatured alcohol is flammable and toxic to eyes skin and respiratory tract. Wear chemical protective gloves and goggles/face shield. Avoid repeated or prolonged contact. Use only in well ventilated areas(or use approved respirator as determined by local safety/industrial hygiene personnel). Keep away from open flames, welding or other sources of ignition.

Isopropyl alcohol, TT-I-735 is flammable and toxic to eyes, skin and respiratory tract. Wear protective gloves and goggles/shield. Avoid repeated or prolonged contact. Use only in well ventilated areas (or use approved respirator as determined by local safety/industrial hygiene personnel). Keep away from open flame other sources of ignition.

**(b) Method B.** Tubing shall be flushed with naphtha, Federal Specification TT-N-95. Tubing is then blown clean and dry of all solvent with water-pumped air. Tubing shall be flushed with anti-icing fluid, Military Specification TT-I-735, or anhydrous ethyl alcohol, Federal Specification O-E-760, Class A, and rinsed with fresh water. Tubing is dried with a stream of clean, dry, water-pumped air or by heating at a temperature of 250 to 300 degrees F (121 to 149 degrees C for a suitable period. After cleaning, aluminum tubing should be treated with a brush coat of chemical film MIL-C-5541. If light corrosion is found, apply a coat of enamel over chemical film. In cases of severe corrosion pitting, replace the tubing.

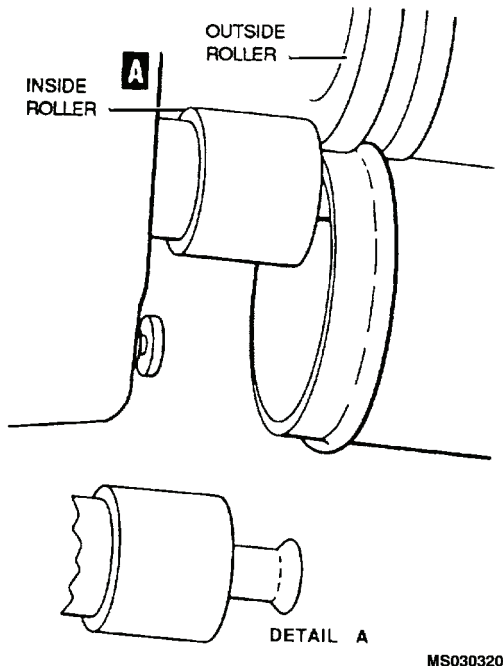


Figure 4-12. Beading Large Tubing

**h. Beaded Tubing Joints.** Beaded joints are used on low pressure lines. The most practical and rapid way of forming beads is by using a tool with a rolling action as shown in figure 4-12. Dimensions for beaded joints are given in figure 4-13.

**i. Installation of Flared Tubing.** Before installing a tube assembly in an aircraft, inspect the line carefully. Remove dents and scratches, and be sure all nuts and sleeves are snugly mated and securely fitted by proper flaring. The tube assembly should be clean and free of all foreign matter.

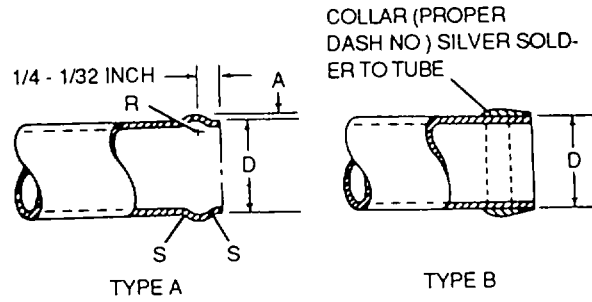
**AN parts in tube assemblies.** In the manufacture of tube assemblies, an AN818 nut and an MS20819 sleeve are used with the flared end of the tube for attaching tube assembly to other AN parts in the aircraft system. A AN817 sleeve nut is available for the same functional purpose, but is not widely used (see figure 4-14). All of these fittings have straight threads conforming to MIL-S-7742. Government Standard fittings have superseded all other types of fittings, and should be used in preference to all others.

#### NOTE

The Department of Defense is in the process of changing AN designations for Government Standard parts of MS designations. Any information pertaining to AN parts is equally pertinent for MS parts which supersede AN parts.

..... **Tubing fittings AN 818 and MS 20819.** The AN 818 nut is made of steel or aluminum alloy and MS 20819 sleeves are made from corrosion-resistant steel. These parts are shown installed in figure 4-15. On these fittings, size is given as a dash number which equals the tubing outside diameter in sixteenths of an inch.



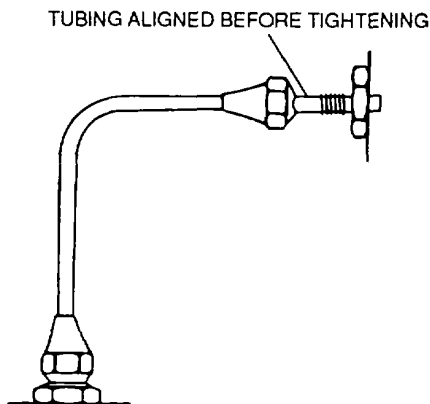


D TUBE OUTSIDE DIAMETER (INCHES)	A 0 003 BEAD HEIGHT (INCHES)	R MAX RADIUS (INCHES)	S MAX RADIUS (INCHES)	COLLAR	
				CORROSION RESISTANT STEEL	BRASS
1/4	0 031	1/8	1/16		
5/16	0 033	1/8	1/16		
3/8	0 035	1/8	1/16		
1/2	0 038	1/8	1/16		
5/8	0 038	1/8	1/16		
3/4	0 038	1/8	1/16	AN876-12	AN876-12B
1	0 062	5/32	3/32	AN876-16	AN876-16B
1 1/4	0 062	5/32	3/32	AN876-20	AN876-20B
1 1/2	0 072	5/32	3/32	AN876-24	AN876-24B
1 3/4	0 072	5/32	3/32	AN876-28	AN876-28B
2	0 082	5/32	3/32	AN876-32	AN876-32B
2 1/2	0 082	5/32	3/32	AN876-40	AN876-40B
3	0 082	5/32	3/32	AN876-48	AN876-48B

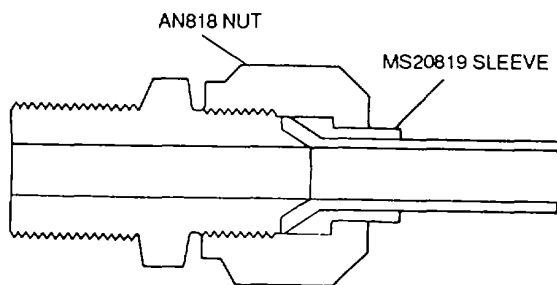
NOTE  
 USE OF TYPE A AND B OPTIONAL ON CORROSION  
 RESISTANT STEEL AND BRASS TUBING 3/4 INCH  
 OVER REMOVE ALL BURRS AND SHARP EDGES

Figure 4-13. Bead Dimensions

**NOTE**



**Figure 4-14. Tube and Fitting Alignment**



**Figure 4-15. Tubing Fittings**

Depot level activities, including commercial contractors, affecting overhaul, repair, or modification of service aircraft are prohibited from using antiseize compounds on flared tubing threads. These activities will replace fittings that are manufactured to maximum or minimum thread tolerances.

(d) *Replace cracked fitting sleeves.* Cracked fitting sleeves installed on fuel, hydraulic, water, and pneumatic tubing subjected to pressures up to and including 3000 psi are not considered unsafe and do not need to be replaced unless a leak occurs. If a leak occurs, they must be replaced. An exception to this is when a line is disconnected for any other reason, all cracked fitting sleeves shall be replaced with serviceable fitting sleeves. These Instructions also apply to cracked fitting sleeves on return, vent, and drain lines. The above statements are not to be interpreted to mean that a cracked fitting sleeve or sleeves cannot be replaced at the discretion of responsible quality control personnel. Minor surface corrosion on sleeves and fittings, while not desirable, is acceptable. Whether or not corroded sleeves and fittings will be replaced is also at the discretion of responsible quality control personnel.

(2) *Installation and replacement of tubing assemblies.* Before a tubing assembly is installed in an aircraft, it shall be carefully inspected. Dents and scratches shall be removed, proper nuts and sleeves installed, and a proper fit obtained where tubing is flared. Tubing assembly shall be clean and free from all foreign matter. Sleeve and nuts shall be screwed to mating fitting by hand and nuts tightened with proper wrench. Tubing shall not be pulled into place with the nut, but shall be properly aligned prior to tightening. If tubing assembly is long; edges of cutout shall be taped before tubing is installed. The fitting wrench or open end wrench shall be used when tightening. Pliers shall never be used to tighten fittings. Adjustable open end wrenches may be used only when proper tools are not available. Overtightening nuts may severely damage or completely cut off tubing flares or may result in damage to sleeve or nut of fitting. If nut and sleeve are removed from a section of tubing, and flares are found to retain less than 50 percent of their original wall thickness, tube shall be replaced. Undertightening nuts may also be serious, as this may allow tubing to blow out or leak at fitting because of insufficient grip on flare by sleeve. Use of torque wrenches will prevent undertightening. A nut shall never be tightened to a torque when pressure is on system, as this will tend to cut flare without adding

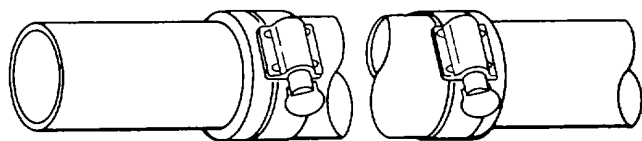
(b) *Identification of tubing fittings.* AN fittings are easily identified by their distinguishing colors; blue for aluminum alloy and black for steel. Aluminum-bronze fittings are cadmium plated, and are not otherwise colored. Only steel fittings are used with steel tubing 3/8-inch outside diameter and smaller. Intermixing of tubing and fittings, other than above is permissible.

(c) *Thread compounds.* Thread compounds should not be used on flared tubing fitting threads. Use of thread compounds should be limited to tapered male pipe threads. In rare instances, it is possible to obtain a flared tubing fitting manufactured to maximum tolerance which, when coupled to a tubing nut manufactured to minimum tolerance, will be difficult to tighten. If this occurs, organizational, and direct and general support maintenance activities are authorized to apply tape, MIL-T-27730, to the first three threads to reduce friction. Tape should not be allowed on the fitting cone as this will prevent metal-to-metal contact.

any appreciable torque to fitting Maximum wrench torques, in inch-pounds, for fitting nuts on various sizes and types of tubing are shown in table 4-2.

*j. Installation of Beaded Tubing.* Beaded tubing is used in low-pressure applications using rubber hose and hose clamps (see figure 4-16).

(1) *Proper sealing of hose connections.* To prevent breakage of hose clamps and damage to hose, instructions on tightening hose clamps shall be followed carefully. When available, use any approved torque wrench to torque hose clamps as per (2) or (3) below,



**Figure 4-16. Installed Low-Pressure Hose**

depending on the hose type. In the absence of a hose clamp torque wrench, the fingertight-plus-turns method shown in table 4-3 should be used. Due to the variance in hose clamp design and hose structure, values given in table 4-3 are approximate and care should be exercised when tightening clamps by this method.

**NOTE**

Aircraft hose constructed with synthetic compound has tendency to cold flow. Therefore, when new hose is installed, clamps should, after a period of time, be retightened in order to maintain original torque value. This is caused by synthetic rubber flowing from under clamping area and not from loosening of clamps

**Table 4-2. Hydraulic Tubing B-Nut (AN818) Torque Values**

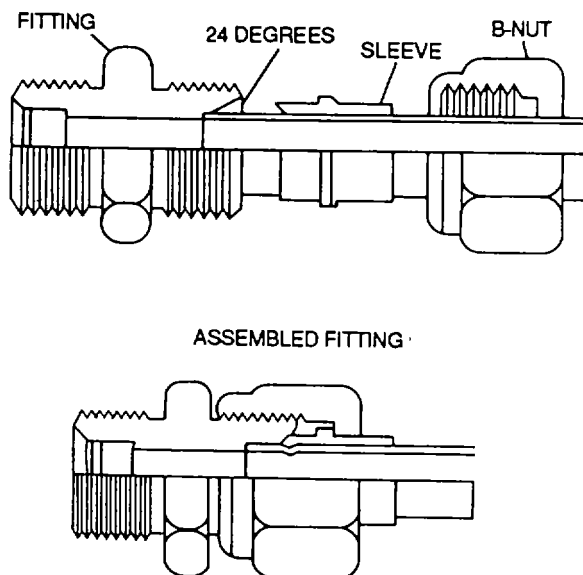
Tube outside diameter	Torque on tube nut	
	Aluminum alloy tubing	Steel tubing
1/4 Inch	40-65 Inch-Pounds	135-150 Inch-Pounds
5/16 Inch	60-80 Inch-Pounds	180-200 Inch-Pounds
3/8 Inch	75-125 Inch-Pounds	270-300 Inch-Pounds
1/2 Inch	150-250 Inch-Pounds	450-500 Inch-Pounds
5/8 Inch	200-350 Inch-Pounds	650-700 Inch-Pounds
3/4 Inch	300-500 Inch-Pounds	900-1,000 Inch-Pounds
1 Inch	500-700 Inch-Pounds	1,200-1,400 Inch-Pounds

**Table 4-3. Hose Clamp Tightening, Fingertight-Plus Turns Method, Beaded Tubing**

Clamps, radial Initial Installation only	Clamp, worm screw-type (10 threads per inch)	and other type (28 threads per inch)
Self-Sealing Hose Complete Turns	Fingertight Plus 2 Complete Turns	Fingertight Plus 2 1/2
Approximately 25 to 30 Inch-Pounds All Other Aircraft Hose Approximately 25 to 30 Inch-Pounds	Fingertight Plus 1 1/2 Complete Turns	Fingertight Plus 2 Complete Turns

(2) *Clamps on self-sealing hose.* Hose clamps installed on self-sealing hose shall be tightened to a torque of 25 inch-pounds minimum to 30 inch-pounds maximum for original installation, and maintained at this torque value. When sealing is not effective at 30 inch-pounds, component parts of connection shall be examined, and unserviceable parts replaced. Under no circumstances shall hose clamp be tightened in excess of 30 inch-pounds in an attempt to effect sealing. This added torque will reduce safety factor of hose clamps as well as destroy hose and connection.

(3) *Clamps on nonself-sealing hose.* Hose clamps installed on nonself-sealing hose shall be installed and maintained at a torque of 25 inch-pounds minimum to 30 inch-pounds maximum. If satisfactory sealing is not accomplished at a torque of 30 inch-pounds, component parts of connection shall be examined and unserviceable parts replaced.



**Figure 4-17. MS Fitting and Components**

**4-3. Fittings.** Hydraulic fittings are used throughout the hydraulic system to provide simple connections between hydraulic components and tubing. Standard MS (flareless) and AN (flared) fittings are used in Army aircraft. Both types are made in many different shapes and designs. They may be ordered in either male or female design or in a combination design (male on one end and female on the other). The hydraulic repairer is concerned with installing both the AN and MS fittings in aircraft hydraulic systems. Normally, the fittings to be used in an aircraft hydraulic system are selected according to the design of the system. The hydraulic repairer repairs fitting failures by duplicating the original installation.

a. *Flareless Fittings.* The main feature of MS fittings is that they can be used to connect unflared tubing. An MS fitting has a counterbore in which the tube end is installed. In the half-sectional view of an MS fitting in figure 4-17, notice the 24-degree beveled portion of the counterbore and its seat. The seat forms a slope for the tube during the connection of one tube to another tube or for a tube to a component and the beveled area causes the tube connector sleeve to seal the connection as the tube B-nut is tightened.

(1) *Identification of flareless fittings.* MS fittings are made of aluminum alloy or steel. Aluminum alloy fittings can be identified visually by their yellow color, which is caused from the anodizing treatment. The cadmium plating on steel fittings are identified by letter-number codes; for example, MS21900-4, which is interpreted as follows:

MS.....prefix (military specification)

21900...design part number (adapter, flareless tube to AN flared tube)

4.....size of fitting in sixteenths of an inch (4/16 (inch))

The material from which the fittings are made is indicated by the absence of a letter at the end of the MS number or by the addition of a letter at the end of the number, for example:

MS21900-4 is made from carbon steel

MS21900-8-D is made from aluminum alloy

MS21900-8-S is made from corrosion-resistant steel, class 347

(2) *Types of flareless fittings.* See figure 4-18 for examples of MS flareless fittings.

### WARNING

Compressed air shall not be used for cleaning purposes unless reduced to less than 30 psi and then only with effective chip-guarding and personal protective equipment.

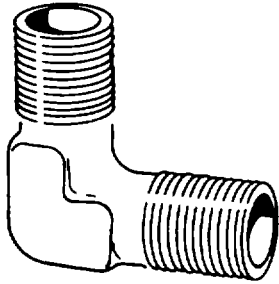
(3) *Installation of flareless fittings.* MS fittings must be inspected before installation. If it is impossible to see through a fitting or tube, blow clean, dry compressed air through it to be certain that no obstructions exist. Any lines that have caps removed in storage or before installation should be flushed with clean hydraulic fluid. Male threads and sleeves of the fittings being assembled should be lubricated with the type of hydraulic fluid used in the system. On fittings with tapered threads, use antiseize compound on the threads, except for the first three, which are left dry.

(a) *Gasket.* To make a connection between tubing and a component, the proper gasket is selected, lubricated, and installed in position as shown in figure 4-19. The fitting is screwed into the boss of the component until it bottoms on the boss.

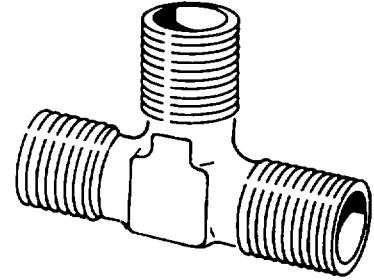
(b) *Installing tubing.* When connecting tubing to an MS fitting, the tube should be aligned with the fitting and the nut should be started by hand without excessive strain on the line (see figure 4-20). Do not use force to align tubing. Tube alignment can often be obtained by loosening clamps on connecting lines or by rotating fittings. Both ends of the tubing should be connected and tightened until a decided increase in resistance to turning of the B-nut is encountered. At this point, tighten the clamps, ensuring that they do not pull the tubing out of alignment and place it in a binding position. Complete the installation by turning the B-nut one-sixth of a turn. See figure 4-21 for turns and torque values. Pressurize the hydraulic system and inspect for leaks. If leakage is noted, release system pressure and completely loosen the B-nut. If possible, rotate the sleeve to a new position and then retorque the B-nut to its previous position plus one-sixth of a turn. Normally this will stop the leak, but if it does not, replace the assembly.



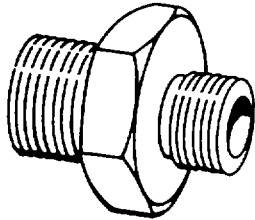
MS21904  
ELBOW



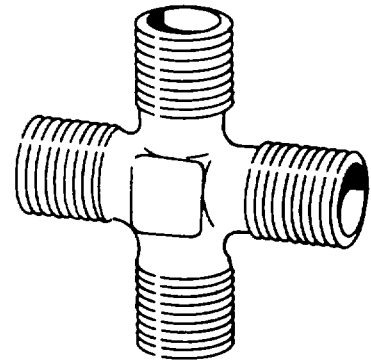
MS21905  
TEE



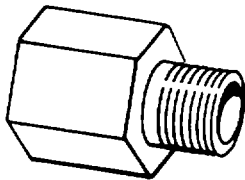
MS21916  
REDUCER



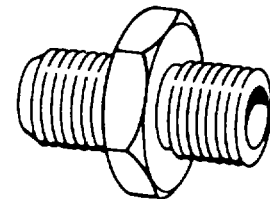
MS21906  
CROSS



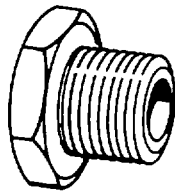
MS21915  
BUSHING



MS21902  
UNION



MS21913  
PLUG



MS21914  
CAP

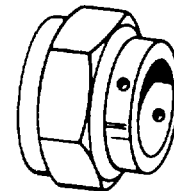


Figure 4-18. MS Flareless Fittings

(c) *Tube-to-tube connections.* To make a tube-to-tube connection, the tube B-nut is tightened until a definite resistance is felt and is then turned one-sixth of a turn farther. The upper wrench is held stationary while the lower wrench is moved upward until the B-nut is tightened a sufficient amount (see figure 4-22). On this tube connection, like most others, a 1/8-inch colored stripe may be painted across the completed assembly so that loosening can be readily detected (see figure 4-23).

(4) *Bulkhead fitting installation.* These fittings are used for connecting tubing to components of the system, and for connecting sections of tubing where the line passes through a bulkhead and the fitting is secured to the bulkhead, as shown in figure 4-24. Refer to table 4-4 for the correct fitting size.

(a) *Hand presetting of MS21922 sleeve.* The MS21922 sleeve can be preset using the following procedures:

1 Bottom the tube end firmly in the seat of the preset tool or fitting.

2 Tighten the MS21921 nut 1 1/6 turns past the point of ring grip on all sizes and materials for all types of fittings or tubes.

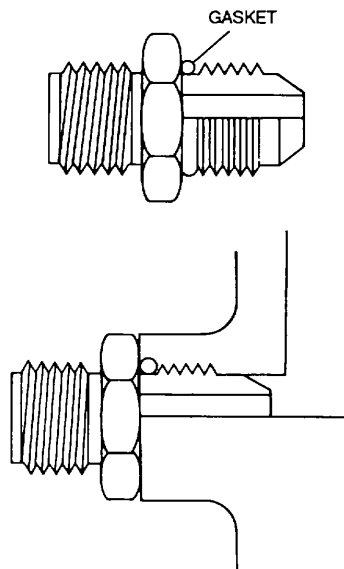


Figure 4-19. MS Fitting Gasket Installation

(b) *Resetting (Installation).* Tighten the MS21921 nut in accordance with table 4-5.

(c) *Boss installation of MS33514 fitting end, style E.* This fitting can be installed as follows

1 Lubricate the packing in appropriate lieid (refer to table 4-6).

2 Install packing on the fitting as shown in detail A, figure 4-25

3 Screw the fitting assembly into the boss using installation torque in accordance with table 4-7

(d) *Installation of AN 924 jamnut.* Torque values can be found in table 4-8.

b. *Oxygen System Tapered Pipe Thread.* Tapered pipe thread fittings are a versatile and efficient method of connecting tubing to components.

(1) *Tubing fittings tapered pipe threads.* Pipe threads should conform to MIL-P-710-5. Straight thread and tapered pipe thread are shown in figure 4-26.

**NOTE**

When installing pipe thread fittings, fittings should be tightened but not enough to damage threads or crack the part in which fitting is being installed.

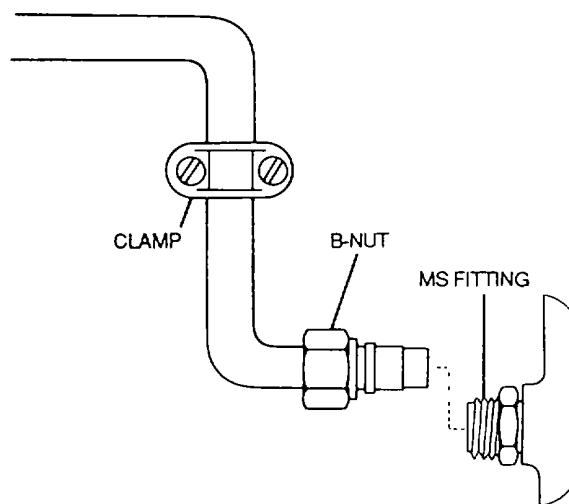


Figure 4-20. Tubing Alignment

TUBING	SIZE	TORQUE (INCH POUNDS)	TIGHTENING - RULE OF THUMB (FLAT TURNS AFTER PRETIGHTENING)	
			NORMAL TIGHT	EXTRA TIGHT
ALUMINUM OR STEEL	-3	65 TO 95		
	-4	100 TO 150	1 TO 1 1/2	2 MAXIMUM
	-6	175 TO 300	1 TO 1 1/2	2 MAXIMUM
	-8	325 TO 500	1 TO 1 1/2	2 MAXIMUM
	-10	400 TO 700	1 TO 1 1/2	2 MAXIMUM
	-12	500 TO 800	1 TO 1 1/2	2 MAXIMUM
	-16	500 TO 800	1 TO 1 1/2	2 MAXIMUM
ALUMINUM	-20 -24	600 TO 900 600 TO 900	1 TO 1 1/2 5/6 TO 1	2 MAXIMUM 1 1/2 MAXIMUM

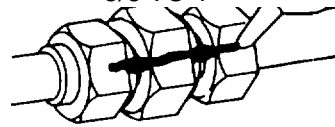
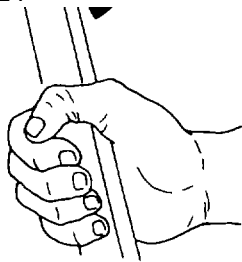


Figure 4-21. MS Turns and Torque Values

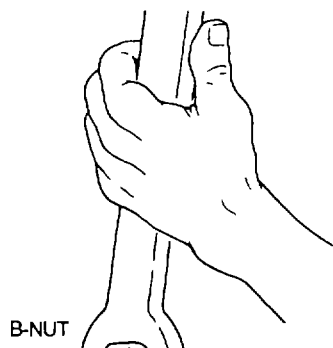
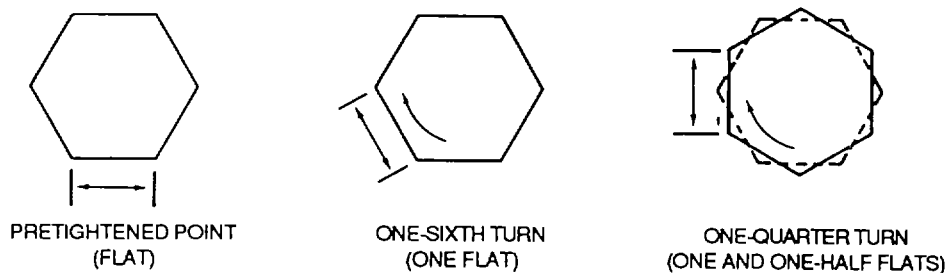
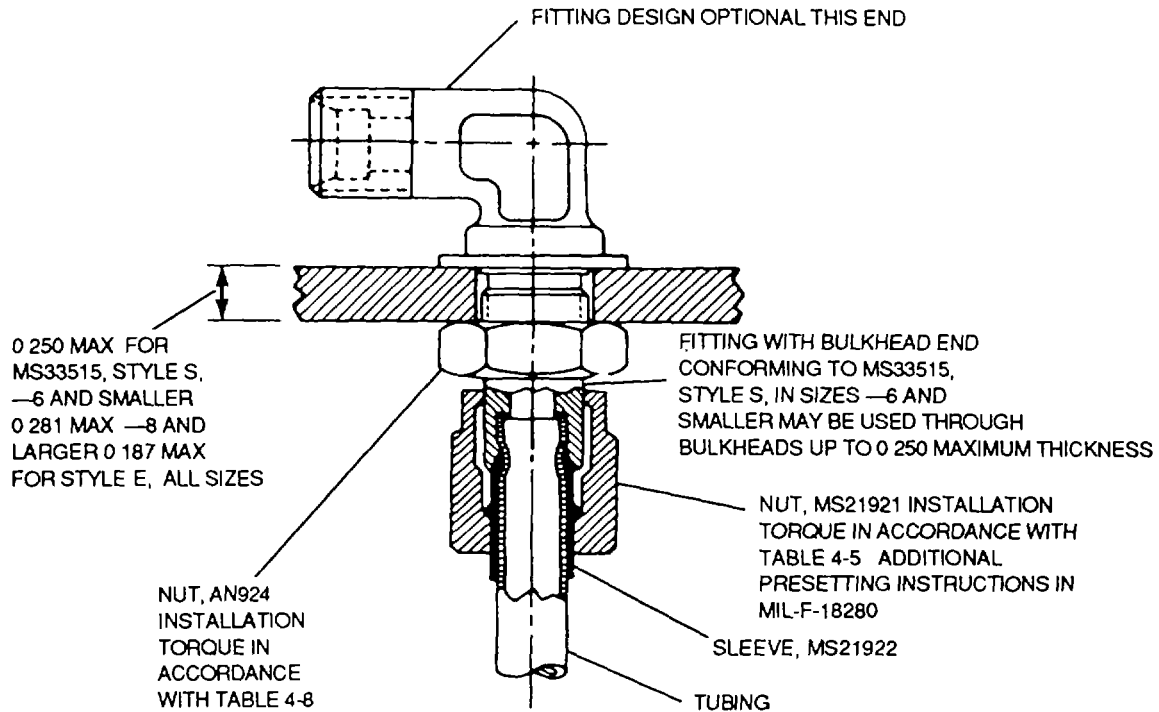


Figure 4-22. Tubing-To-Tubing Connections



Figure 4-23. Marking MS Fitting



**Figure 4-24. Bulkhead Flareless Fitting Installation**

**Table 4-4. Bulkhead Flareless Fitting Installation**

Fitting size	Bulkhead hole dla (ret)*	AN960 washer thickness (bulkhead 0.187 thick or less)	Fitting size	Bulkhead hole dla (ref)	AN960 washer thickness (bulkhead 0.187 thick or less)
-2	0.318/0.338		-10	0.880/0.900	
-3	0.380/0.400		-12	1.068/1.088	
-4	0.443/0.463	0.062	-16	1.318/1.338	0.094
-5	0.505/0.523		-20	1.630/1.650	
-6	0.568/0.588		-24	1.880/1.900	
-8	0.755/0.775	0.094	-32	2.505/2.525	

**NOTE**

For hole sizes shown (based on AN9601D), no washer required with MS33515, Style S For bulkheads thicker than 0.187 or with MS33515, Style E for all thickness.

(a) *Theory of pipe thread seal.* The threaded portion of a pipe fitting is tapered so that when it is tightened, the part with the external thread (male) is forced into the internally threaded (female) part, creating a seal.

(b) *Tightening fittings with pipe threads.* Extreme care shall be taken when tightening pipe fittings. Overtightening causes distortion, cracking, and leaks. Tighten 1/8-inch fittings to a torque of 125 to 175 Inch-pounds, 1/4-inch fittings of 200 to 300 inch-pounds, and 3/8-inch fittings to a torque of 300 to 400 Inch-pounds.

(2) *Tubing fitting thread lubricants.* Various lubricants and antiseize compounds are used on threads to prevent seizing and difficulty in disassembly. Threads that give the most trouble are male and female cast aluminum alloy tapered pipe threads. Pipe threads secure their sealing features by interlocking of threads. Threads being tapered become highly stressed in final torqued condition. Due to this high stress and peculiar stress-strain characteristics of aluminum alloy, threads may deform permanently, causing sufficient misalignment to make it difficult to disassemble unit. It is highly desirable that male parts be made of different material and properly lubricated with antiseize compound. Federal Specification TT-S-1732, or equivalent Low pressure lines with low torque anodized aluminum alloy fittings and with antiseize compound used, may be disassembled under normal conditions.

c. *Straight Pipe Thread.* Straight pipe thread is used on fittings in hydraulic components connected to tubing. It is shown in figure 4-26.

d. *Universal Fittings AN 832, AN 833, and AN 834 Low Pressure.* These fittings are used for connecting tubing to components of the system and for connecting sections of tubing where the line passes through a bulkhead and fitting is secured to the bulkhead. These fittings are satisfactory for pressures up to and including 1000 psi. For information pertaining to systems of over 1000 psi, refer to paragraph e. Bulkhead fittings shall be installed on system components as follows:

(1) Assemble nut on fitting end and screw all the way back to clear gasket groove.

(2) Place gasket or equivalent performed packing in gasket groove.

(3) Screw fitting into boss until gasket contacts boss.

(4) Unscrew fitting to approximate position desired but not more than 360 degrees

(5) Tighten locknut lightly.

(6) Assemble flared tubing to fitting.

(7) Tighten locknut against boss

e. *Universal Fittings AN832, AN833, and AN834 High Pressure.* It is necessary to use a backup washer in the check nut when combination bulkhead and universal fittings are installed in bosses on systems where pressures exceed 1000 psi. This method eliminates the possibility of high pressure extending the rubber gasket into threaded areas of fitting. A leather washer (MS28777) is used to prevent this extrusion of the rubber gasket. A Teflon backup ring (MS9058) is used in lieu of the leather washer in systems where temperature in excess of 1600 F (710 C) are anticipated. The method of installation is as follows:

(1) Install nut as high up on fitting as possible. Add leather washer and gasket in position shown in detail A, figure 4-27.

(2) Screw fitting assembly into boss until first thread at top of fitting groove is from 3/16- to 1/8-inch from top surface of boss, as shown in detail B, figure 4-27.

(3) Hold fitting stationary and screw nut down until it seats on boss. Slight extrusion of leather washer between surface of boss and nut is considered satisfactory, as shown in detail C, figure 4-27.

(4) Tighten locknut against boss

f. *Rosan Fluid Fittings.* The Rosan fluid fitting is a one-piece, thin wall insert with an external locking. The Rosan insert is fabricated from 6AL-4V titanium per AMS4967. The locking is fabricated from A-286 or rosin-resistant steel per AMS5734 and is retained on the insert by a controlled interference fit. The Rosan fluid fitting is used to provide semi-permanent port mounted installations and is compatible with Denature or flared tube ends. The unique features of the Rosan fluid fitting are as follows.

(1) Lockring provides positive lock.

(2) No lacquering required.

**Table 4-5. Torque Values for MS21921 Coupling Nut Based on Lubrication Method, or Dry (Lubrication-None) as Directed in Applications Column and Appropriate Lubricant Column, Table 4-6.**

Tube	Code <sup>1</sup>	Alum (6061-T6) tubing wall thickness (in)		Torque (lb in.)	
		heavy	thin	min.	max.
-2					
-2					
-2	A, B			50	60
-2					
-3	C	0.028		95	105
-3					
-3	A, B			95	105
-3					
-4	C	0.035		135	145
-4	D		0.028	120	135
-4	A, B			135	145
-4					
-5					
-5					
-5	A, B			170	190
-5					
-6	C	0.049		215	245
-6	D		0.028	190	215
-6	A, B			215	245
-6					
-8	C	0.065		470	510
-8	D		0.035	340	380
-8	D		0.049	340	380
-8	A, B			470	510
-10	C	0.083		620	680
-10	D		0.035	380	450
-10	D		0.049	380	450
-10	A, B			620	680
-12	C	0.095		855	945
-12	D		0.049	400	470
-12	D		0.065	400	470
-12	A, B			855	945
-16	C	0.065		1140	1260
-16	D		0.049	750	850
-16	A, B			1140	1260

See footnotes at end of table.

**Table 4-5. Torque Values for MS21921 Coupling Nut Based on Lubrication Method, or Dry (Lubrication - None) as Directed in Applications Column and Appropriate Lubricant Column, Table 4-6 - CONT**

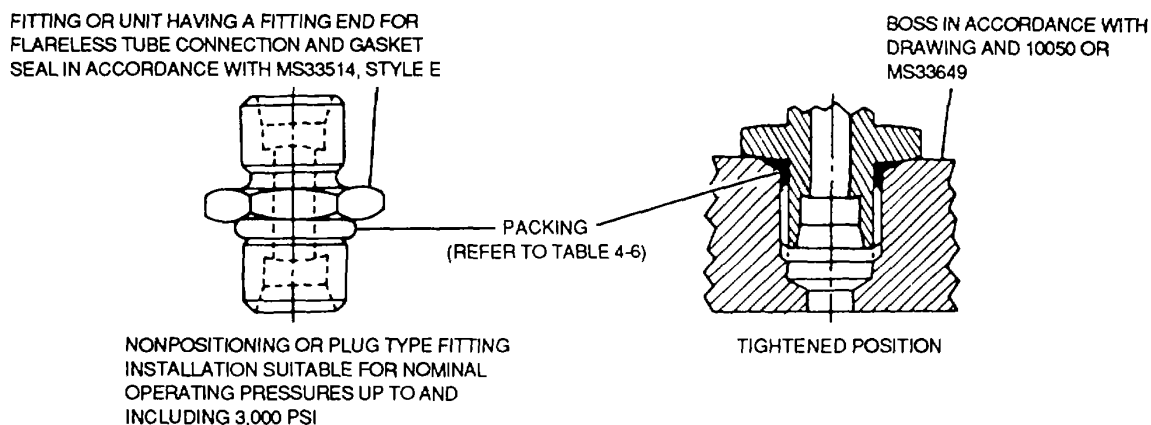
Tube	Code <sup>1</sup>	Alum (6061-T6) tubing wall thickness (in)		Torque (lb in.)	
		heavy	thin	min.	max.
-20					
-20	D		0.049	1000	1100
-20	A, B			1520	1680
-20					
-24					
-24					
-24	A, B			1900	2100
-24					
-32					
-32					
-32	A, B			2660	2940
-32					

**<sup>1</sup>Code**

- A Steel, corrosion-resistant or titanium nut tube or fitting.
- B Aluminum fittings or nuts used with cres tubing.
- C Aluminum fittings or nuts used with heavy wall aluminum tubing (6061-T6).
- D Aluminum fittings or nuts used with thin wall aluminum tubing (6061-T6).

**Table 4-6. Packing and Lubricant Selection.**

Application	Specification number	Appropriate lubricant
Hydraulic (Petroleum Base)	MS28778, MIL-R-83248/1, MS 3393, MIL-R-83248/2	System Fluid
Hydraulic (Phosphate Ester)	NAS1612	System Fluid
Pneumatic	MS 9385	MIL-G-4343
Engine Lubricant (Petroleum Base)	MS 9387	System Fluid
Engine Lubricant (Synthetic Base)		
Engine fuel (Gasoline: JP-3, -4, -5, -6; RJ-1; RP-1; HEF-2)		
Oxygen	MS 9385	None
Vacuum	NAS 1596	None
Coolant (Ethylene Glycol)	MS28778	None
Coolant (Silicate Esters)		



**Figure 4-25. Installation of MS33514 Fitting End**

**Table 4-7. Torque Values for Boss Installation Using Packings (In-Lb) (Fittings Per MS33514, Style E, AN6289 Nut Used With Fittings Per MS33515, Style E or S, all Materials, Based on Lubrication Method, or Dry (Lubrication - None) as Directed in Applications Column and Appropriate Lubricant Column, Table 4-6)**

Size	Tube OD (in.) (ref)	Thread	Torque	
			min.	max.
-2	1/8 (0.125)	5/16-24	50	55
-3	3/16 (0.187)	3/8 -24	65	75
-4	¼ (0.250)	7/16-20	95	105
-5	5/16 (0.312)	1/2 -20	125	135
-6	3/8 (0.375)	9/16-18	155	165
-8	½ (0.500)	3/4 -16	280	305
-10	5/8 (0.625)	7/8 -14	380	405
-12	¾ (0.750)	1 1/16-12	550	600
-16	1 (1.000)	1 5/16-12	800	900
-20	1 ¼ (1.250)	1 5/8 -12	900	1000
-24	1 ½ (1.500)	1 7/8 -12	900	1000
-32	2 (2.000)	2 1/2 -12	900	1000

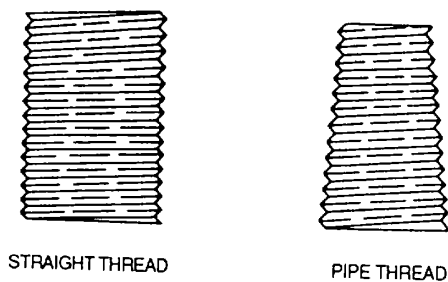


**Table 4-8. Torque Values for AN924 Jamnut Used on Fittings Per MS33515  
 Style E or S In Bulkhead Installations (In-Lb)**

Size	Tube OD (in.)		Thread	Torque	
		(ref)		min.	max.
-2	1/8	(1.25)	5/16 - 24	35	50
-3	3/16	(1.87)	3/8 - 24	65	80
-4	1/4	(0.250)	7/16 - 20	85	105
-5	5/16	(0.312)	1/2--20	105	125
-6	3/8	(0.375)	9/16 - 18	120	150
-8	1/2	(0.500)	3/4 - 16	240	280
-10	5/8	(0.625)	7/8 - 14	320	380
-12	3/4	(0.750)	1 1/16--12	500	600
-16	1	(1.000)	1 5/16--12	720	880
-20	1 1/4	(1.250)	1 5/8--12	960	1200
-24	1 1/2	(1.500)	1 7/8--12	1200	1440
-32	2	(2.000)	2 1/2 - 12	1400	1500

**NOTE**

Fitting shall be restrained from turning when torquing to values given in table 4-6 and this table.



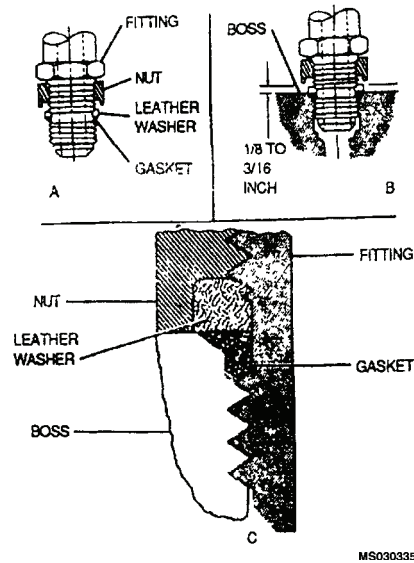
(3) Standard fitting ends per MS33656, MS33514 or Denature.

(4) Quick replacement of packing without damage to the fitting or port.

(5) Standard packings used in assembly.

(6) Only one wrench required during removal and installation of tubing.

**Figure 4-26. Straight Thread and Pipe Thread**



**Figure 4-27. Combination Bulkhead and Universal Fitting Assembly**

(7) Installation of Rosan Fluid Fitting will be installed in accordance with TM 43-0104.

**g. Flared Fitting.** Flared fittings, like flareless (MS) fittings, come in many different shapes. The main difference between AN and MS fittings is the manner in which the hydraulic tube fits to the fitting. The MS fitting has a counterbore in which the tubing is inserted; the AN fitting has a 37 degree flared (beveled) face to which the tubing is fitted. This flared area of the fitting is the sealing surface and must be maintained. Any bad flare on this sealing surface will show up as a hydraulic leak.

(1) **Identification.** AN flared fittings can be identified by the part number, as described in table 4-9.

(2) **Types.** See figure 4-28 for examples of flared fittings.

(3) **Use of old fittings in oxygen systems.** In repairing oxygen systems, it is usually possible to use the old fittings. Fittings should be cleaned before they are installed. Refer to paragraph 4-2 g (2) for cleaning procedure for oxygen fittings.

(4) **Repairing tubing fittings.** See figure 4-29 for repairable and non-repairable defects of tubing fittings. Tubing fittings may be repaired provided 80 percent of seat remains after repair. The only marks allowed on seat surface are annular tool marks of 100 micro inches root mean square maximum. Fittings that cannot be salvaged by this method should be rejected. Reworked aluminum alloy fittings should be anodized. Minor scratches are not cause for replacement. If wrench damage to a hexagonal section of a fitting does not exceed one corner, it should be reworked with a fine file in such a manner as to leave no file marks. A maximum of one corner may be reworked provided 75 percent of reworked flange width is not damaged. Damaged threads should be inspected and repaired.

**NOTE**

All screw threads MIL-S-7742, that are within the pitch diameter tolerances of Class 2, after rework, are acceptable for further use.

Deleted

High pressure hose end fitting assemblies, 300 psi and swage-type fittings of any pressure range, should not be reworked. MIL-F-8789 states that MS28760 and MS28761 fittings should be used only once.

Coupling nuts sometimes modified for use on hose end fitting assemblies are not interchangeable with AN818 nuts. All AN fittings that cannot be salvaged by this repair should be condemned.

- **4-4. REPAIR OF TUBING ASSEMBLIES.** Scratches or nicks no deeper than 10 percent of the wall thickness in aluminum alloy tubing may be repaired, if they are not in the heel of a bend. Replace lines with severe die marks, seams, or splits in the tube Any crack or deformity in a flare is also unacceptable and is cause for rejection. A dent of less than 20 percent of the tube diameter is not objectionable, unless it is in the heel of a bend. Dents can be removed by drawing a bullet of the proper size through the tube by means of a length of cable.

**Table 4-9. AN Flared Fitting Identification**

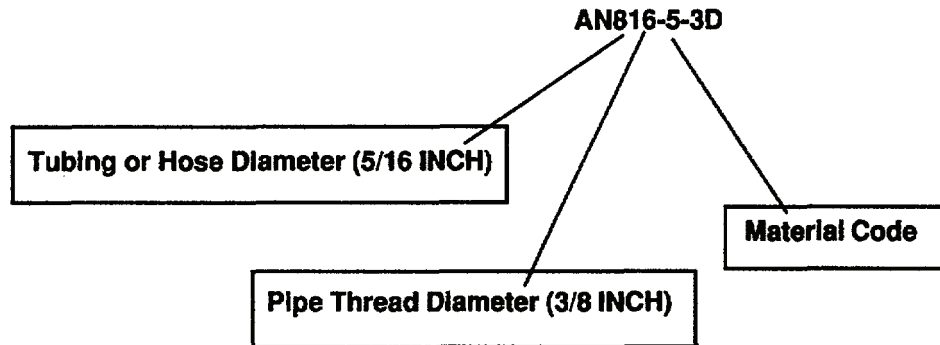
	Material	Color	Code
	Aluminum Alloy	Blue	D
	Steel	Black	None
	Brass	Natural	B
AN 819 (Sleeves)	Aluminum Bronze	Cadmium Plated	Z

**NOTE**

Size: The dash number following the AN number indicates the size of the tubing (or hose) for which the fitting is made, in 16ths of an inch. This size measures the O. D. of tubing and the I. D. of hose. Fittings having pipe threads are coded by a dash number, indicating the pipe size in 8ths of an inch. The material code letter, as noted above, follows the dash number.

EXAMPLE:

**EXAMPLE:**



MS030336

- a. **Precautions.** The following precautions should be followed to ensure an effective repair:

- (1) Take extreme care to remove all chips, burrs, and foreign material from tubing during repair.

(2) Any open line or fitting that will be left unattended will be capped or plugged to prevent possible contamination of the entire hydraulic system.

**b. Repair of Low-Pressure Tubing Assemblies .** Low-pressure tubing assemblies can be repaired by the following procedures:

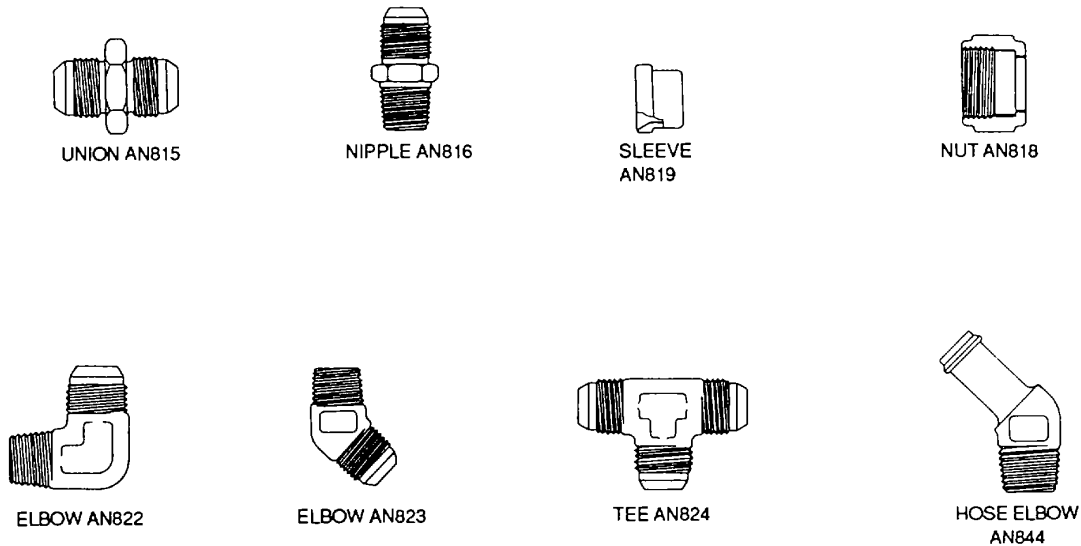
(1) Remove damaged portion of tube, deburr remaining ends, and remove cuttings from tube interior (see figure 4-30).

(2) If possible, bead remaining tube ends.

(3) Cut a repair section of same diameter as damaged tubing 1/2 inch shorter than removed damaged portion. Deburr repair section and bead. Clean tube.

(4) Cut two synthetic hose connections of proper length and install a hose clamp over each end of each hose connection. Slip both hose connections well back over original tube. See figure 4-31 for tubing clearances.





**Figure 4-28. AN Flared Fittings**

(5) Position repair insert

**NOTE**

When positioning hose clamps or tightening screws, care should be taken to prevent screws from chafing or damaging adjacent parts. Where such damage is possible, hose clamps should be repositioned on hose.

(6) Slip hose connections midway over junction formed by original tube and repair section Use glycerine, Federal Specification O-G-491, on metal pipe to aid sliding of rubber hose.

(7) Tighten hose clamps. To prevent breakage of hose clamps and damage to hose, instructions on tightening hose clamps shall be followed carefully When available, use any approved torque wrench to torque clamps as per (a) OR (b) below, depending on the hose type. In the absense of a hose clamp torque wrench, the fingertight-plus-turnsmethod shown In table 4-10 should be used. Due to the variance In hose clamp design and hose structure, values given in table 4-10 are approximate and care should be exercised when tightening clamps by this method.

**NOTE**

Aircraft hose constructed with synthetic compound has a tendency to cold flow, therefore, when new hose is installed, clamps should, after a period of time, be retightened In order to maintain original torque value. This is caused by synthetic rubber flowing from under clamping area and not from loosening of clamps.

(a) Hose clamps installed on self-sealing hose shall be tightened to a torque of 25 Inch-pounds minimum to 30 Inch-pounds maximum for original installation, and maintained at this torque value When sealing is not effective at 30 Inch-pounds, component parts of connection shall be examined, and unserviceable parts replaced Under no circumstances shall hose clamp be tightened In excess of 30 Inch-pounds In an attempt to effect sealing This added torque will reduce safety factor of hose clamp as well as destroy hose and connection.

(b) Hose clamps installed on nonself-sealing hose shall be installed and maintained at a torque of 25 inch-pounds minimum to 30 Inch-pounds maximum. If satisfactory sealing is not accomplished at a torque of

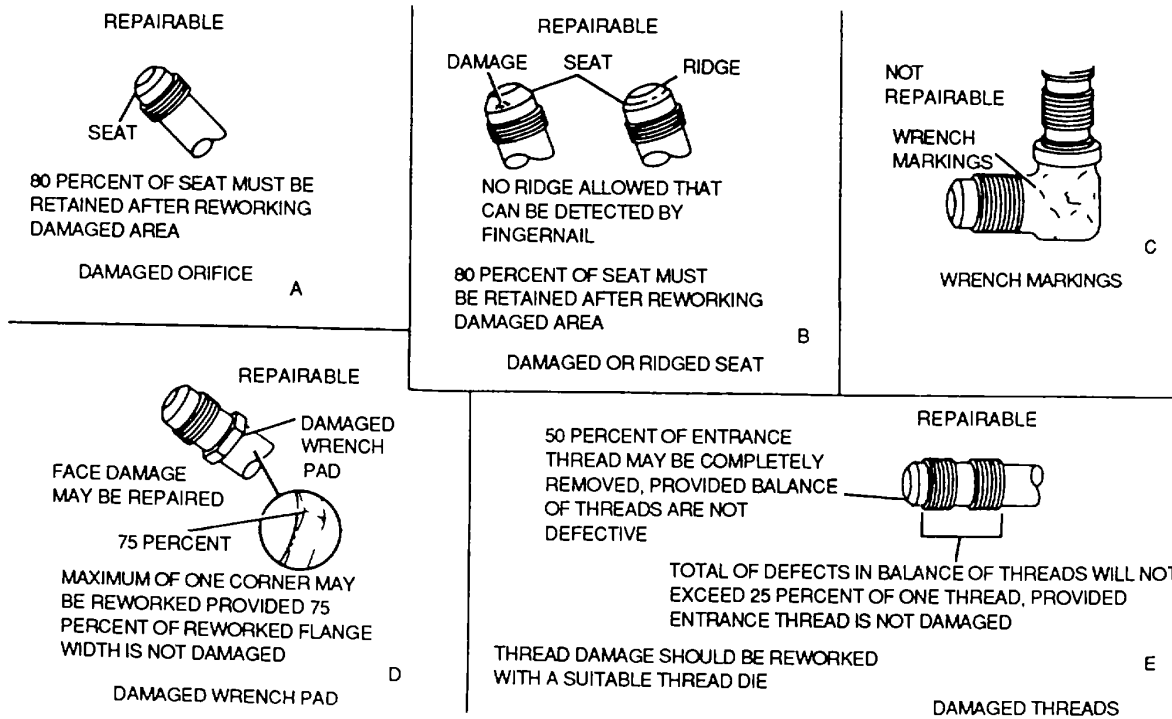


Figure 4-29. Damaged Fittings

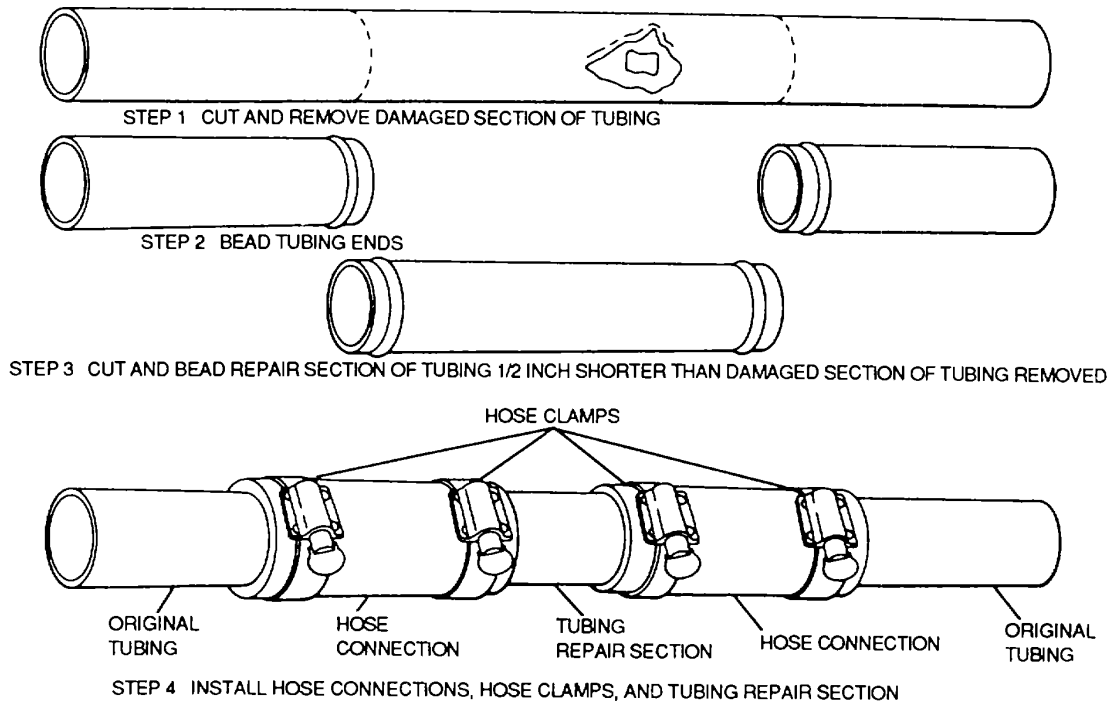
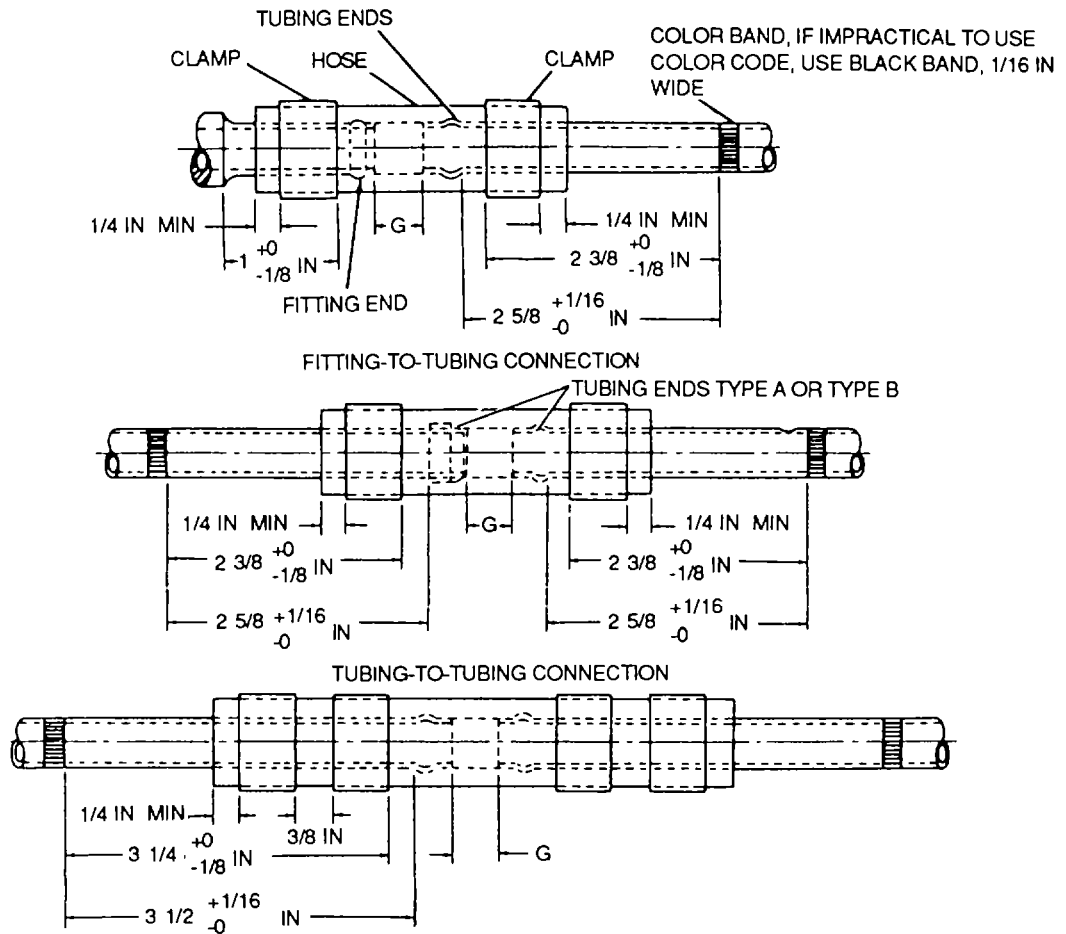
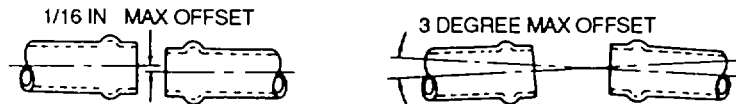


Figure 4-30. Repair of Low-Pressure Tubing



USE OF DOUBLE HOSE CLAMPS PERMITTED ONLY WITH THE SPECIFIC APPROVAL OF AVSCOM (UNLESS SPECIFIED ON ORIGINAL INSTALLATION DRAWING)

TUBING-TO-TUBING CONNECTION USING DOUBLE HOSE CLAMPS



MINIMUM GAP G SHALL BE 1/2 INCH OR TUBING OD, WHICHEVER IS GREATER

4

MAXIMUM GAP G IS NOT LIMITED EXCEPT ON SUCTION LINES USING OTHER THAN SELF-SEALING HOSE ON SUCH SUCTION LINES, MAX G SHALL BE 1-1/2 IN OR ONE TUBE DIAMETER, WHICHEVER GREATER

AID FOR DETERMINING HOSE LENGTH				
CONNECTION	HOSE OVER FITTING	GAP G	HOSE OVER TUBING (ONE END)	TOTAL HOSE LENGTH
FITTING-TO-TUBING CONNECTION	1 3/8 IN	ACTUAL GAP	1 1/2 IN	2 7/8 IN + GAP
TUBING-TO-TUBING CONNECTION		ACTUAL GAP	1 1/2 IN	3 IN + GAP
TUBING-TO-TUBING CONNECTION USING DOUBLE HOSE CLAMPS		ACTUAL GAP	2 1/2 IN APPROX	5 IN + GAP

Figure 4-31. Tubing End Clearance for Low-Pressure Tubing Repair



**Table 4-10. Hose Clamp Tightening, Fingertight-Plus Turns Method**

Instal Installation only	Clamp, worm screw-type (10 threads per Inch)	Clamps, Radial and other type (28 threads per Inch)
Self-Sealing Hose Complete Turns	Fingertight Plus 2 Complete Turns	Fingertight Plus 2 1/2
Approximately 25 to 30 Inch-Pounds All Other Aircraft Hose Approximately 25 to 30 Inch-Pounds	Fingertight Plus 1 1/2 Complete Turns	Fingertight Plus 2 Complete Turns

30 inch-pounds, component parts of connection shall be examined and unserviceable parts replaced.

(c) Hose clamps installed on rubber nipple-type fuel cell fittings and fuel system molded rubber connections shall be tightened to a torque of 15 inch-pounds for original installation, and maintained at finger-tight plus 1 1/4 turns. Fuel cell fittings are very easily damaged by hose clamps; therefore, these torque values shall be followed.

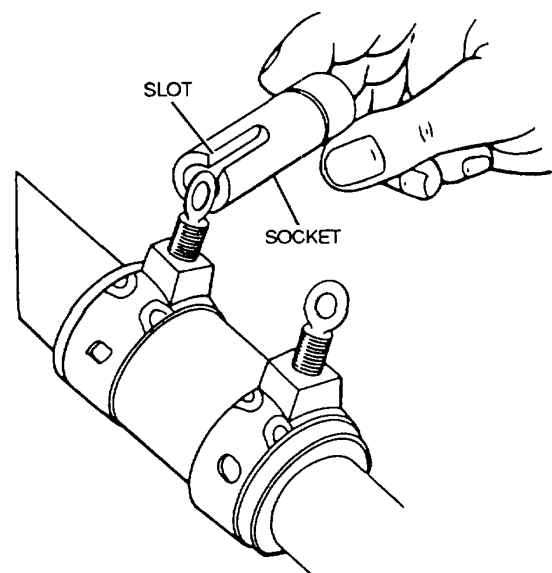
(d) As an alternate method, hose clamps may be tightened with a special hose clamp tool easily fabricated from a long midget socket (figure 4-32) A slot is cut through hex end of socket wide enough and deep enough to accommodate thumbscrew portion of hose clamp. This type of tool may be used on the end of a ratchet or extension.

c. Repair of High-Pressure Tubing Assemblies  
 High-pressure tubing assembly can be repaired either by removal of the damaged section and a union installed, or by replacement of the entire tubing assembly.

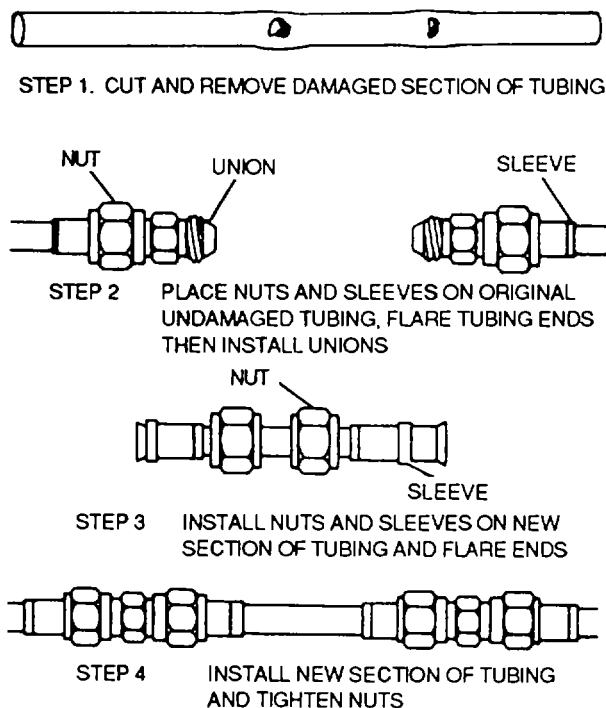
(1) *Repair.* The damaged portion of tubing is cut out and removed (see figure 4-33). The ends of the remaining tubing are cleaned and deburred. If the damaged section of the tubing does not exceed the length of a union, a new tube section is not needed.

(2) *Replacement.* If a tubing assembly is to be replaced, fittings can usually be salvaged and replacing

assembly will amount to replacement of tubing only. If tubing is small and made of soft material, assembly may be formed during installation by hand bending. However, if tubing is of such material and size that hand bending is impractical, care shall be taken to remove assembly without further damage or distortion so that it can be used as a forming template. This will allow duplication as to length, bends, and angles. All tubing for replacement in low pressure oxygen systems shall



**Figure 4-32. Tightening Hose Clamp with Socket**



**Figure 4-33. Repairing High-Pressure Tubing**

be made of aluminum alloy conforming to Federal Specification WW-T-700/4.

**NOTE**

Copper tubing of same outside diameter and wall thickness may be used in oxygen systems only in case of emergency, and should conform to Federal Specification WW-T-799, Type N. Steel tubing shall not be used because it loses its ductility and becomes brittle at low temperature.

(a) *Tubing material.* When replacing a damaged tubing assembly, the same size and material shall be selected. Where like materials are not available, wall thickness which can be used for various diameters and tubing materials under applicable system pressure are shown in table 4-11. The following paragraphs explain the use of this table.

1 *Explanation of codes.* The following information applies to the code symbols. The codes shown in table 4-11 indicate that these sizes are standard.

CODE	TUBING MATERIAL	SPECIFICATION
a	Aluminum 5052-0	FED SPEC WW-T-700/4
b	Aluminum 2024T	FED SPEC WW-T-700/3
c	Corrosion-Resistant Steel Annealed	MIL-T-8504
d	Corrosion-Resistant Steel 1/4 hard	MIL-T-6845

2 *Minimum burst pressures.* In accordance with MIL-H-5440, the following minimum tube burst pressures are required for the noted system procedures:

SYSTEM PRESSURE	BURST PRESSURE
1,000	4,000
1,500	6,000
3,000	12,000

3 *Conversion factors.* Following are the conversion factors for the materials in table 4-1 1 and the three system pressures.

MATERIAL CODE	SYSTEM PRESSURE (PSI)	CONVERSION FACTOR
a	1,000	1,380
	1,500	2,070
	3,000	4,140
b	1,000	625
	1,500	938
	3,000	1,875
c	1,000	533
	1,500	800
	3,000	1,600
d	1,000	333
	1,500	500
	3,000	1,000

4 Use of table. For example, the minimum standard wall thickness must be determined for a 1/2 inch outside diameter (OD), 1/4 hard corrosion-resistant steel tube for a 3,000 psi system. From the above paragraph, the conversion factor is 1000. From table 4-1 1, the nearest value must be found that applies to this material This value is 1,120. This indicates a 1/2 inch OD x 0.028 inch tube, which is a standard size indicated by the code d for 1/4 hard corrosion-resistant steel.

5 Burst pressure. Taking any value from the table, it is easy to determine the actual burst pressure for a tube The following factors are multiplied by the pressure values shown in table 4-11 to produce the actual burst pressure

MATERIAL CODE	BURST PRESSURE FACTOR
a	2.9
b	6.4
c	7.5
d	1.2

For example, the system pressure producing 10,000 psi stress on the wall of a 1/4 inch OD x 0.012 annealed corrosion-resistant steel tube is 960 If the system pressure is 1,500 psi, the minimum burst pressure is 6,000. Multiplying 960 by the burst pressure factor of 7.5 for this material, the actual burst pressure is 7,100 psi, well above the minimum of 6,000 required for this system.

(b) Layout. A piece of tubing approximately 10 percent longer than length of tubing to be replaced should be cut. After required bends have been made, new tubing may be 1/2 to 2 inches longer than old tubing Allowances should be made for flaring operation. The amount of tubing in excess of amount required to flare tube should be cut off.

**NOTE**

After cutting, bending, and flaring operations, oxygen tubing assemblies should be cleaned in accordance with paragraph 4-2g (2)

d. Template. A path should not be selected that requires no bends unless original tubing had a path with no bends A section of tubing cannot be cut and flared accurately enough to be installed without bends and still avoid initial mechanical strain on tubing except in

straight runs not having rigid connections on each end. A fluid line is a mechanical part when installed, and is sensitive to vibration; therefore, direct, straight-line connections shall never be made between two solid fixed attachment points, as bends allow tubing to expand and contract under temperature differences. All bends shall be started a reasonable distance from fittings, so sleeve and nut can be slipped back along tubing for inspection. This will also prevent tubing from binding against sleeve Tubing assemblies shall be formed prior to installation so it will not be necessary to pull assembly into alignment by use of coupling nut If old tubing is intact and the bends have not been changed, it may be used as a template. If rerouting is required and a new template must be made, proceed as follows:

- 1 Place material selected for use as a template into one of the fittings where tube is to be connected.
- 2 Form necessary bends in template.
- 3 Remove template and use pattern to bend new tube
- 4 Select path with least total degrees bend. This reduces flow loss and simplifies bending.
- 5 Use path, if possible, with all bends in same plane.
- 6 Lay out path which provides for either brackets or clamps to be used as supports at intervals not greater than those given in table 4-12.

**4-5. Flexible Hose Assemblies.** Flexible hose is used in aircraft plumbing to connect moving parts with stationary parts in locations subject to vibration or where a great amount of flexibility is needed. It can also serve as a connector in metal tubing systems

**WARNING**

Do not use flexible hose and hose assemblies in oxygen systems, as they readily absorb grease and oil. Failure to comply may result in damage to aircraft or injury to personnel

a. Identification of Flexible Hose. Aircraft hose or hose assemblies can be readily identified as to age and

**Table 4-11. Determining Tube Thickness and Burst Pressure**

Outside diameter (inches)	Tube thickness (inches)					
	0.012	0.016	0.020	0.028	0.035	0.042
1/8	c, d 1920	2560	c, d 3200	a, c, d 4480	a, c, d 5600	6720
3/16	1280	c, d 1707	c, d 2133	a, c, d 2987	a, b, c, d 3733	b 4480
1/4	c, d 960	c, d 1280	c, d 1600	a, b, c, d 2240	a, b, c, d 2800	3360
5/16	c, d 768	c, d 1024	c, d 1280	b, c, d 1792	a, b, c, d 2240	a 2638
3/8	640	854	c, d 1067	a, b, c, d 1493	a, b, c, d 1867	a, b 2240
1/2	480	640	c, d 800	a, b, c, d 1120	a, b, c, d 1400	a 1680
5/8	384	512	c, d 640	a, b, c, d 896	a, b, c, d 1120	a 1344
3/4		427	c, d 533	b, c, d 747	b, c, d 933	b 1120
1		320	400	a, c, d 560	a, b, c, d 700	840
1 1/8		284	356	498	b, c, d 622	747
1 1/4		256	320	448	a, b, c, d 560	672
1 3/8		233	291	407	c, d 509	611
1 1/2		213	267	a 373	b, c, d 467	c, d 560
2		160	200	280	a, b, c, d 350	420

**Table 4-11. Determining Tube Thickness and Burst Pressure-CONT**

Outside diameter (inches)	Tube thickness (inches)						
	0.049	0.058	0.065	0.083	0.095	0.109	0.120
1/8	7840						
3/16	b, c, d 5227	6187	6933	8853			
1/4	b, c, d 3920	b 4640	5200	6640	7600	8720	
5/16	b, c, d 3136	b, c, d 3712	b, c, d 4160	b 5312	b 6080	6976	7680
3/8	a, b, c, d 2613	b, c, d 3093	b, c, d 3466	b, c, d 4427	b 5067	b 5813	6400
1/2	a, b, c, d 1960	a, b, c, d 2320	a, b, c, d 2600	b, c, d 3320	b, c, d 3800	b 4360	b, c, d 4800
5/8	a, b, c, d 1568	b, c, d 1856	a, b, c, d 2080	b 2656	b, c, d 3040	3488	c, d 3840
3/4	b, c, d 1307	b, c, d 1547	b, c, d 1733	b, c, d 2213	2533	2907	b, c, d 3200
1	a, b, c, d 980	b 1160	a, b, c, d 1300	b, c, d 1660	b 1900	2180	c, d 2400
1 1/8	b, c, d 871	b, c 1031	b, c, d 1156	b 1476	1689	b 1938	b, c, d 2133
1 1/4	a, b, c, d 784	b 928	b, c, d 1040	1328	1520	1744	b, c, d 1920
1 3/8	b, c, d 713	b, c, d 844	b 945	b, c, d 1207	1382	1585	1745
1 1/2	a, b, c, d 653	b, c, d 773	a, b, c, d 867	b 1107	b, c, d 1267	1453	b 1600
2	a, b, c, d 490	b 580	a, b, c, d 650	b 830	b, c, d 950	1090	b 1200

manufacturer by code markings which are repeatedly stenciled along the full length of the hose.

(1) *Markings*. The identification markings will either be manufacturer's code number or manufacturer's symbol, also date of manufacture in quarter year and year, size of hose, and specification of hose in numerals (figures 4-34 through 4-38).

(2) *Stripe*. The indicator stripe or code symbol along length of hose shall, in all cases, identify hose manufacturer.

(3) *Temperature range*. The indicator stripe indicates that hose is suitable for use through a temperature range of -65 to 160° F (-54 to 71 ° C).

(4) *Hose*. MIL-H-8788. This hose will appear in assemblies only

(a) *Markings*. Hose in each assembly will be marked with quarter year and year of manufacture of hose, hose size, specification number, and an indicator stripe in the form of a yellow dot and dash code, showing direction of natural lay of hose. Markings are repeated at intervals of not more than 9 inches along length of hose.

(b) *Identification tag*. This hose is also identified by a removable metal tag or band, installed at the factory when hose is assembled, showing part number of hose assembly, date of assembly, and name or trademark of manufacturer.

b. *Storage of Hose and Hose Assemblies*. Hose or hose assemblies shall be stored as follows:

Do not store hose or hose assemblies in piles. To do so will result in decreased strength and integrity.

(1) Seal both ends of bulk hose. Cap or plug each hose or hose assembly as outlined in paragraph 4-51.

(2) Store hose or hose assemblies on racks which support and protect hose and hose assemblies.

(3) Store hose or hose assemblies so that older items are used first.

c. *Replacement of Flexible Hose*. Inspection and replacement of hose or hose assemblies will be accomplished at inspection periods prescribed in applicable aircraft maintenance manual or whenever defects listed below are evident.

(7) *Deterioration*. Replace all hose and hose assemblies showing signs of deterioration indicated by separation of rubber cover or braid from inner tube, cracks, hardening and lack of flexibility.

(2) *Cold Flow*. Replace hose or hose assemblies showing signs of excessive cold flow indicated by deep permanent impressions and cracks in hose or cover produced by pressure of hose clamps and head of nipple chafing.

(3) *Weather checking*. Weather checking of rubber is caused by sunlight and atmospheric oxidation.

(a) *Early stages*. Rubber hoses, tubing or rubber outer coated surfaces will show fine line cracks or crazing but will be pliable when squeezed between the fingers or rolled between the hands. This is a sign of the early stages of deterioration.

(b) *Advanced deterioration*. As deterioration continues, the cracks and crazing become more prominent, and when the rubber hose or tubing is squeezed or rolled, the item will break, shatter, or turn to powder, thus becoming useless.

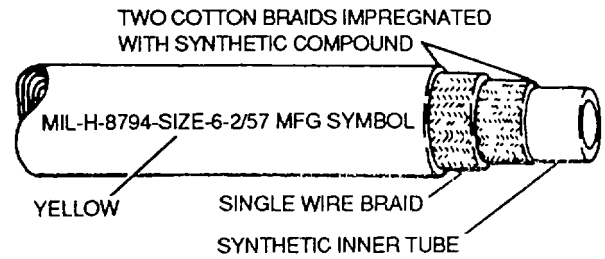
(c) *Inspection*. Rubber products should be carefully inspected prior to installation and during use for weather checking.

(d) *Replacement*. Replace hose or hose assemblies with weather checking that is deep or wide enough to expose fabric.

**NOTE**

- The black rubber coming out between the wire braid only occurs with hose which conforms to MIL-H-83797. This is a result of the manufacturing process and is normal.
- The replacement hose shall be a duplicate of hose removed as to the length, OD, ID, and contour (except as directed).

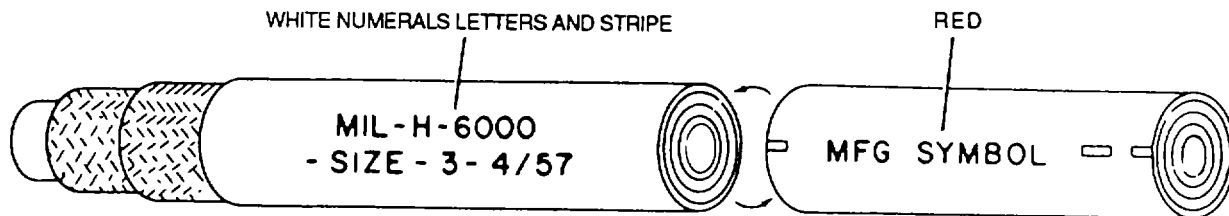
(4) *Excessive wire damage.* (Braided wire cover). Wire damage can be identified using the following guidelines.



**Figure 4-34. Flame and Aromatic-Resistant Hose, MIL-H-8794**

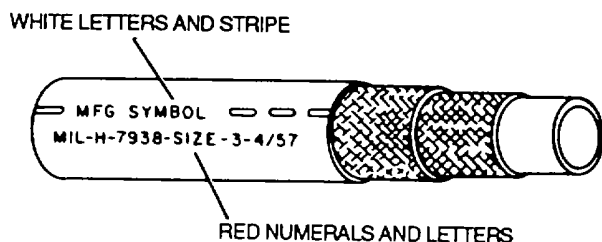
**Table 4-12. Maximum Distance between Supports for Fluid Tubing, Military Specification MIL-H-5440**

Tubing outside diameter (Inches)	Distance between supports (Inches)	
	Aluminum alloy	Steel
1/8	9 1/2	11 1/2
3/16	12	14
1/4	13 1/2	16
5/16	15	18
3/8	16 1/2	20
1/2	19	23
5/8	22	25 1/2
3/4	24	27 1/2
1	26 1/2	30 1/2
1 1/4	28 1/2	31 1/2
1 1/2	29 1/2	32 1/2



VIEW SHOWING OPPOSITE SIDES OF HOSE

**Figure 4-35. Nonself-Sealing, Aromatic and Heat-Resistant Hose, MIL-H-6000**



**Figure 4-36. Flame Aromatic, and Oil-Resistant Hose MIL-H-7938**

**NOTE**

Whenever operating pressure of a hose assembly is unknown, it will be assumed to be 1500 psi or greater

(a) *Below 30psi.* For hose assemblies used as vents and hose assemblies which operate below 30 psi, excessive wire damage as described herein will not apply. Replacement of these assemblies will be at the discretion of the local inspector/mechanic using good shop practice and experience.

(b) *Below 500 psi.* For hose assemblies which operate below 500 psi, excessive wire damage consists of four or more broken wires in a single plait,

12 or more broken wires per assembly or per lineal foot whenever assemblies exceed 12 inches in length.

(c) *Above 500 psi.* For hose assemblies which operate at 500 psi and above, excessive wire damage consists of two or more broken wires in a single plait, two or more adjacent wires, one or more broken wires in an area where kinking is suspected, six or more broken wires per assembly or per lineal foot whenever assemblies exceed 12 inches. Crossed reinforcing or random broken wires are not causes for rejection.

(5) *Leakage.* Hose assemblies will be replaced when leakage occurs with hydraulic pressure applied.

(6) *Static leakage.* With no pressure applied, leakage exceeding one drop per hour will be cause for replacement of the assembly.

(7) *Abrasion, kinking, distortion, bulging, collapse, or sharp bending.* Any evidence of these conditions will require replacement of hose assemblies

**NOTE**

Hoses need to be changed for abrasion only if the metal reinforcement is exposed (this note does not apply to braided wire covered hoses).

(8) *Internal damage.* Inspect internal restriction due to collapse, wire braid puncture, or other damage by one of the following methods.



(a) *Internal inspection.* The various constructions of hose assemblies are inspected as follows:

1 *Straight hose assemblies.* Insert light at one end and inspect by looking through from the opposite end.

2 *Hose assembly with elbow fitting one end.* Insert flexible inspection light into elbow fitting and examine by looking through from the opposite end

3 *Hose assembly with elbow fittings both ends.* Insert flexible inspection light into one end and examine from the opposite end using a dental-type mirror. This procedure is practical on large size hose assemblies only.

(b) *Other configurations and small size hose assemblies.* Pass a ball of proper size (refer to table 4-13) through the hose assembly to check for restriction or kinking.

d. *Instructions for Repair of Flexible Rubber Hose.*  
Replace all defective hose assemblies without attempting repair. MS28759, MS28762, MS28741, and AN 6270 hose assemblies are field fabricated, and are replaced as a complete unit. However, fittings from the old hose assemblies should be reused on the new assemblies when they are in good condition All factory assembled hose, or field assembled hose which has been in storage, shall be subjected to pressure test prior to installation in accordance with paragraph 4-5f

e. *Instructions for Assembly of High Pressure (3000 psi) Hose Assemblies MS28759 and MS28762.*  
High pressure hose assemblies MS28759 and MS28762 are fabricated from high pressure bulk hose conforming to MIL-H-8788 or MIL-H-8790, and fittings conforming to Military Standards MS28760 and MS28761

(1) *Visually check bulk hose.* Visually check bulk hose when hose is cut for assembly. Check hose for mutilations, mandrel joints, marks, seams, and excessive graphite

(2) *Visually check fittings.* Check fittings for

- Mutilations, nicks, and distortions caused by overtightening, scratches, or other damage to the cone seat sealing surface.
- Backed out retaining wires on swivel nuts.
- Mutilation or other damage to threaded areas.
- Damage to the finish which would affect the corrosion-resistance of the fitting.

#### NOTE

Do not intermix the socket and nipple from one manufacturer with those of another. All fittings are marked with the manufacturer's symbol Also, do not reuse aluminum sockets on high pressure hose fittings.

(3) *Equipment required.* The following equipment is required for field fabrication of high pressure hose assemblies:

- Wire brush or soft wire wheel.
- 6 inch slip-joint pliers.
- Knife (leather or linoleum), ground as shown in figure 4-39.
- Fine tooth hacksaw.
- 10,000 psi hydrostatic test machine.
- Standard wrenches.
- Shop vise.

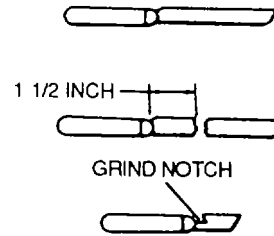
(4) *Determine correct length of hose.* Determine correct length of hose required as shown in table 4-14 and figure 4-40. Cut hose squarely using a fine tooth hacksaw. Using compressed air, clean hose after cutting to remove all cutting residue.

(5) *Hose and fittings assembly.* Assemble hose and fittings using following procedures and figure 4-41, steps 1 through 9:

**NOTE**

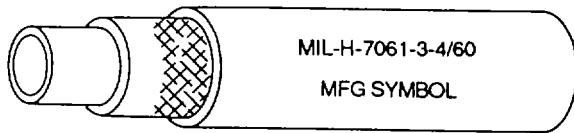
Do not reuse high pressure hose which has been in service. Also, never reinstall a fitting on same area of hose in which it was first installed. If an error is made in assembly, cut away the old area, or use a new length of hose, and reinstall the fitting.

(a) Using position notch on socket (step 1), determine and mark that portion of hose end to be confined within end fitting socket. This amount of hose outer cover is to be stripped.



**Figure 4-39. Knife for Cutting Flexible Hose**

RED NUMERALS, LETTERS, AND STRIPE



**Figure 4-37. Nonself-Sealing, Aromatic-Resistant Hose MIL-H-5593**

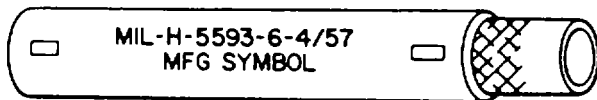
**Table 4-13. Inspection Ball Size Chart**

Hose dash size	Ball size (inches)
-4	3/32
-5	9/64
-6	13/64
-8	9/32
-10	3/8
-12	1/2
-16	47/64
-20	61/64

**NOTE**

These are standard master ball sizes.

YELLOW NUMERALS, LETTERS,  
AND STRIPE



**Figure 4-38. Self-Sealing, Aromatic-Resistant Hose, MIL-H-7061**

**Table 4-14. Hose Cutoff Factor, MIL-H-8788 or MIL-8790 Hose (in Inches)**

<b>Fitting</b>		<b>Hose Size (Dash No. and/or Letter)</b>										
<b>Part No.</b>	<b>-3</b>	<b>-4</b>	<b>-5</b>	<b>-6</b>	<b>-8</b>	<b>-10</b>	<b>-12</b>	<b>-16</b>	<b>-20</b>	<b>-24</b>	<b>-32</b>	
<b>Straight Flared</b>	MS27616		0 92		1.02	1.16						
	MS27053	0.70	0.74	0.77	0 81	0.93	1.05	1.13	1.30	1.44	1.66	
	MS28760		0.79		0.99	1.10	1.19	1.35	1.59			
	MS18085	0.42	0.41	0.42	0.47	0.58	0.63	0.61	0.67	0.79	0.86	
	MS24587	0 60	0.60	0 70	0.77	0.94	1.00	1.00	0.94	0.99	1.09	1.24
	MS27404		0.46		0.55	0.68	0.73					
	MS87018	0.64	0.65	0.70	0.76	0.94	0.99	1.00	1.16	1.34	1.44	1.62
OR												
M83798/1	0 74 <sup>2</sup>	0 74 <sup>2</sup>	0.76 <sup>2</sup>	0.84 <sup>2</sup>	0.97 <sup>2</sup>	1.05 <sup>2</sup>	1.11 <sup>2</sup>	1.34 <sup>2</sup>	1 54 <sup>2</sup>	1.70 <sup>2</sup>		
4												

<b>Fitting</b>		<b>Hose Size (Dash No. and/or Letter)</b>										
<b>Part No.</b>	<b>-3</b>	<b>-4</b>	<b>-5</b>	<b>-6</b>	<b>-8</b>	<b>-10</b>	<b>-12</b>	<b>-16</b>	<b>-20</b>	<b>-24</b>	<b>-32</b>	
<b>45 Degree Flared</b>	MS27617		1.58		1.87	2 16						
	MS27055	1.08	1.18	1 22	1.29	1.79	1.58	2.05	2.14	2.24	2.75	
	MS28780		1 07		1.36	1.45	1.58	2.25	2.47			
	MS18086	1.29	1.28	1.33	1.38	1.44	1.63	2.07	2.29	2.33	2.74	
	MS27226	1.08	1 12	1.34	1.38	1.55	1.70	1.89	1.85	2.16	2.38	2.84
	MS27059	1.08 <sup>3</sup>	1.18 <sup>3</sup>	1.22 <sup>3</sup>	1.29 <sup>3</sup>	1.79 <sup>3</sup>						
	MS87019	1.05	1.02	1.12	1.22	1.30	1.44	1.76	1 83	2.13	2.28	2 69
OR												
M83798/2	0 94 <sup>2</sup>	1.07 <sup>2</sup>	1.14 <sup>2</sup>	1.22 <sup>2</sup>	1.31 <sup>2</sup>	1.44 <sup>2</sup>	1.72 <sup>2</sup>	2.03 <sup>2</sup>	2.31 <sup>2</sup>	2.53 <sup>2</sup>		
4												
	0 77 <sup>3</sup>	0.83 <sup>3</sup>	0.94 <sup>3</sup>	0.97 <sup>3</sup>	1.35 <sup>3</sup>							

See footnotes at end of table.

**Table 4-14. Hose Cutoff Factor, MIL-H-8788 or MIL-8790 Hose (in Inches)-CONT**

<b>Fitting</b>		<b>Hose Size (Dash No. and/or Letter)</b>										
<b>Part No.</b>	<b>-3</b>	<b>-4</b>	<b>-5</b>	<b>-6</b>	<b>-8</b>	<b>-10</b>	<b>-12</b>	<b>-16</b>	<b>-20</b>	<b>-24</b>	<b>-32</b>	
<b>90 Degree Flared</b>	MS27618		1.12	1.25	1.44							
	MS27057	0.86	0.91	0.97	1.03	1.31	1.41	1.92	2.05	2.34	2.68	
	MS28781		0.94		1.21	1.29	1.41	2.24	2.53			
	MS18087	1.03	1.03	1.09	1.15	1.18	1.37	2.00	2.25	2.28	2.28	
	MS27224	0.93	0.99	1.19	1.23	1.39	1.53	1.76	1.75	2.09	2.34	2.80
	MS27060	0.86 <sup>3</sup>	0.91 <sup>3</sup>	0.97 <sup>3</sup>	1.03 <sup>3</sup>	1.31 <sup>3</sup>						
	MS87020	0.89	0.89	0.96	1.07	1.14	1.27	1.63	1.74	2.06	2.22	2.65
	OR											
	M83798/3	0.79 <sup>2</sup>	0.94 <sup>2</sup>	0.98 <sup>2</sup>	1.07 <sup>2</sup>	1.15 <sup>2</sup>	1.27 <sup>2</sup>	1.59 <sup>2</sup>	1.93 <sup>2</sup>	2.23 <sup>2</sup>	2.47 <sup>2</sup>	
	4	0.56 <sup>3</sup>	0.58 <sup>3</sup>	0.60 <sup>3</sup>	0.72 <sup>3</sup>	0.88 <sup>3</sup>						
<b>Fitting</b>		<b>Hose Size (Dash No. and/or Letter)</b>										
<b>Part No.</b>	<b>-3</b>	<b>-4</b>	<b>-5</b>	<b>-6</b>	<b>-8</b>	<b>-10</b>	<b>-12</b>	<b>-16</b>	<b>-20</b>	<b>-24</b>	<b>-32</b>	
<b>Straight Flareless</b>	MS27629		1.07		1.23	1.39						
	MS27381	0.92	0.89	0.93	1.02	1.16	1.32	1.40	1.58	1.72	2.07	
	MS28761		0.94		1.17	1.32	1.42	1.60	1.85			
	MS87021	0.85	0.80	0.86	0.96	1.17	1.26	1.27	1.44	1.62	1.85	
	OR											
M83798/4	0.92 <sup>2</sup>	0.85 <sup>2</sup>	0.89 <sup>2</sup>	1.00 <sup>2</sup>	1.15 <sup>2</sup>	1.15 <sup>2</sup>	1.27 <sup>2</sup>	1.50 <sup>2</sup>	1.69 <sup>2</sup>	2.03 <sup>2</sup>		
4												

See footnotes at end of table.

**Table 4-14. Hose Cutoff Factor, MIL-H-8788 or MIL-8790 Hose (in Inches)-CONT**

Fitting		Hose Size (Dash No. and/or Letter)									
Part No.	-3	-4	-5	-6	-8	-10	-12	-16	-20	-24	-32
<b>45 Degree Flareless</b>	MS27630		1 67		2.00	2.31					
	MS27382	1 23	1.29	1.32	1.43	1.95	1.77	2.23	2.33	2.61	3.03
	MS27384	1.23 <sup>3</sup>	1 29 <sup>3</sup>	1.32 <sup>3</sup>	1 43 <sup>3</sup>	1.95 <sup>3</sup>					
	MS87022	1 20	1.12	1.23	1 36	1.45	1.63	1.93	2.03	2.33	
	OR										
	83798/5 4	1 03 <sup>2</sup> 0.92 <sup>3</sup>	1 77 <sup>2</sup> 0 94 <sup>3</sup>	1.25 <sup>2</sup> 1.05 <sup>3</sup>	1.35 <sup>2</sup> 1 11 <sup>3</sup>	1 46 <sup>2</sup> 1.50 <sup>3</sup>	1.63 <sup>2</sup>	1.90 <sup>2</sup>	2 22 <sup>2</sup>	2.49 <sup>2</sup>	2.80 <sup>2</sup>
Fitting		Hose Size (Dash No. and/or Letter)									
Part No.	-3	-4	-5	-6	-8	-10	-12	-16	-20	-24	-32
<b>90 Degree Flareless</b>	MS27631		1.12		1.25	1.44					
	MS27383	0.86	0.91	0.97	1.03	1.31	1.41	1.92	2.05	2.34	2.68
	MS27385	0.86 <sup>3</sup>	0.91 <sup>3</sup>	0.97 <sup>3</sup>	1.03 <sup>3</sup>	1.31 <sup>3</sup>					
	MS87023	0.89	0.89	0.96	1.07	1.14	1.27	1.63	1.74	2.06	
	OR										
	M83798/6 4	0.79 <sup>2</sup> 0.89 <sup>3</sup>	0.94 <sup>2</sup> 0 89 <sup>3</sup>	0.98 <sup>2</sup> 0.96 <sup>3</sup>	1.07 <sup>2</sup> 1.07 <sup>3</sup>	1.15 <sup>2</sup> 1.14 <sup>3</sup>	1.27 <sup>2</sup>	1.59 <sup>2</sup>	1.93 <sup>2</sup>	2.23 <sup>2</sup>	2.47 <sup>2</sup>

See footnotes at end of table.

**Table 4-14. Hose Cutoff Factor, MIL-H-8788 or MIL-8790 Hose (in Inches)-CONT**

	Fitting		Hose Size (Dash No. and/or Letter)							
	Part No.	-8	-10	-12	-16	-20	-24	-32	-40	-48
<b>Straight Flange</b>	MS27054	1.27	1.35	1.55	1.61	1.69	1.81			
	MS27232	1.64	1.65	1.67	1.53	1.53	1.46	1.66	1.98	1.98
	MS18088	0.53	0.53	0.53	0.53	0.56	0.62			
	MS87024			1.25	1.30	1.50	1.34	1.52		
	OR									
	M83798/7			1.25 <sup>2</sup>	1.46 <sup>2</sup>	1.77 <sup>2</sup>	1.60 <sup>2</sup>			
		4								

	Fitting		Hose Size (Dash No. and/or Letter)									
	Part No.	-3	-4	-5	-6	-8	-10	-12	-16	-20	-24	-32
<b>45 Degree Flange</b>	MS27056	1.25	1.42	1.90	1.98	2.22	2.50					

	Fitting		Hose Size (Dash No. and/or Letter)							
	Part No.	-8	-10	-12	-16	-20	-24	-32	-40	-48
<b>45 Degree Flange</b>	MS27230			1.74	1.69	1.96	2.16	2.50	3.04	3.34
	MS28749	1.44	1.53	1.74	1.69	1.96	2.16	2.51	3.04	3.34
	MS18089	1.35	1.53	1.97	2.14	2.18	2.53			
	MS87025			1.60	1.68	1.93	2.03	2.36		
	OR									
	M83798/8			1.57 <sup>2</sup>	1.87 <sup>2</sup>	2.11 <sup>2</sup>	2.29 <sup>2</sup>			
		4								

See footnotes at end of table.

**Table 4-14. Hose Cutoff Factor, MIL-H-8788 or MIL-8790 Hose (in Inches)-CONT**

<b>Fitting</b>		<b>Hose Size (Dash No. and/or Letter)</b>								
<b>Part No.</b>	<b>-8</b>	<b>-10</b>	<b>-12</b>	<b>-16</b>	<b>-20</b>	<b>-24</b>	<b>-32</b>	<b>-40</b>	<b>-48</b>	
<b>90 Degree Flange</b>	MS27058	1.21	1.42	1.92	2.05	2.34	2.68			
	MS27228			1.76	1.75	2.09	2.34	2.80	3.42	3.80
	MS28750	1.39	1.52	1.76	1.75	2.09	2.34	2.80	3.42	3.80
	MS18090	1.18	1.37	2.00	2.25	2.28	2.78			
	MS87026			1.63	1.74	2.06	2.22	2.65		
OR										
	M83798/9			1.59 <sup>2</sup>	1.93 <sup>2</sup>	2.23 <sup>2</sup>	2.47 <sup>2</sup>			

- <sup>1</sup> Cutoff factor for one fitting.
- <sup>2</sup> Hose fittings manufactured by Stratoflex (98441) have different cutoff factors.
- <sup>3</sup> Forged elbow
- <sup>4</sup> Either part number may be used until one of the part numbers is deleted.

(b) Using knife, cut around mark made in (a) above step 2 of figure 4-40. Make sure cut is through to wire braid. Slit this section of outer cover lengthwise (step 3). Pry up outer cover and use pliers to twist cover off (step 4). Using wire brush or soft wire wheel, remove any rubber particle adhering to the wire braid (step 5). Exercise extreme care when operation to ensure that wire braid is not loosened, frayed, or flared when brushing.

(c) Place socket in a vise. Screw hose into the socket counterclockwise until it bottoms (step b); then back off 1/4 turn.

**NOTE**

Avoid excessive turning of hose in aluminum sockets. This will tend to grind away material from the buttresses inside socket.

(d) Using wrenches, screw nipple end fitting onto nipple end with counterclockwise movement and start nipple hex nut onto opposite end using clockwise movement (step 7).

(e) Lubricate nipple threads (step 8) and inside of hose liberally using a light motor oil or hydraulic fluid, MIL-H-5606.

(f) Position wrench on nipple hex nut and install nipple assembly into socket and hose by turning nut clockwise (step 9). Maximum allowable gap between nipple hex and socket is 1/16 inch.

(6) Inspect hose assembly internally. Inspect hose assembly internally for cut or bridged inner tube, obstructions and cleanliness. Minimum inner diameter for a bulged inner tube is shown in table 4-15. Inspect for proper gap between nipple hex and socket. Ensure that nut swivels freely.

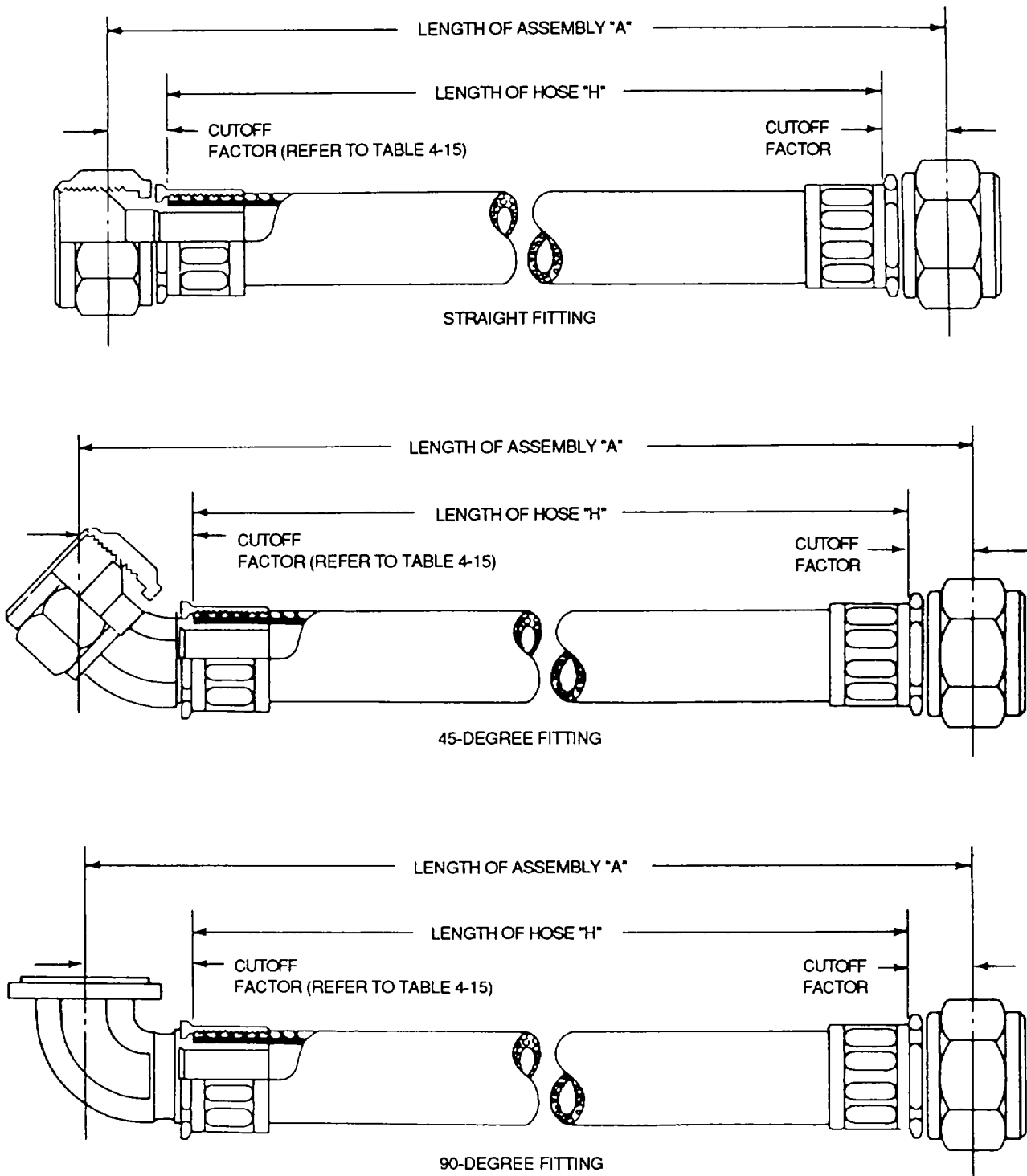
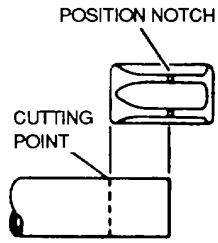
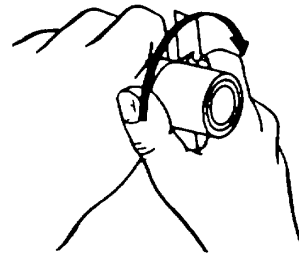


Figure 4-40. Determining Hose Assembly Length

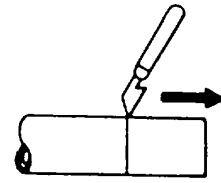




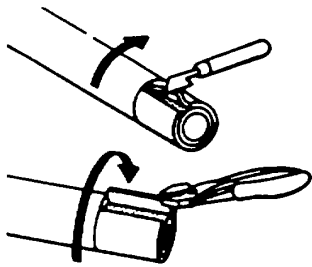
STEP 1



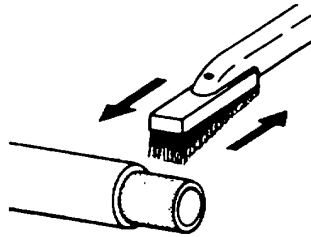
STEP 2



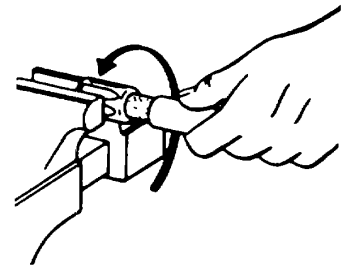
STEP 3



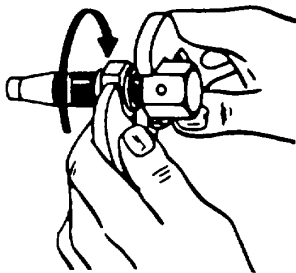
STEP 4



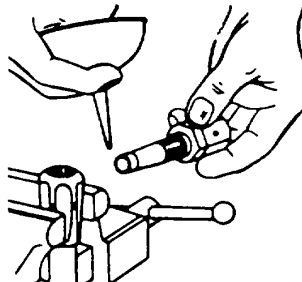
STEP 5



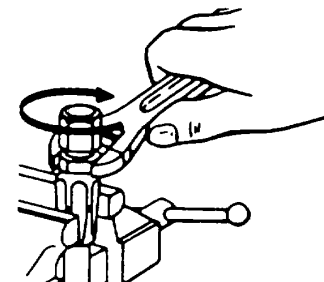
STEP 6



STEP 7



STEP 8



STEP 9

Figure 4-41. Field Fabrication of High-Pressure Hose Assemblies

**WARNING**

Hoses to be tested shall be securely restrained to prevent whipping. In case the fittings should blow off. Longer hoses should have several restraints. The test is best conducted with hose in an enclosure having a heavy transparent plastic cover which can be fastened closed. Personnel shall wear eye and face protection. Failure to comply may result in injury or death.

**CAUTION**

Make no adjustments, under any condition, of assembly gap or position angle after test and final acceptance of completed hose assemblies. Install the following polyethylene protective plugs in end fittings of hose assemblies that are not to be installed immediately after fabrication NAS 815-(*\*size*) A (*\*same dash number as fitting*). Close openings in flanges (or other special fittings) using pressure sensitive tape or other adequate means to prevent entrance of foreign material. Failure to comply may result in contamination of the hydraulic system.

**Table 4-15. Operating, Proof, and Burst Test Pressures for MS28759 and MS28762 Hose Assemblies**

<b>Size</b>	<b>Tube OD (Inches)</b>	<b>Hose assembly</b>	<b>Operating pressure (psi)</b>	<b>Proof pressure (psi)</b>	<b>Burst pressure (psi) (min)</b>	<b>Minimum Inside Bend radius (Inches)</b>	<b>inner dia. at bulge (inches)</b>
-4	1/4	MS28759 MS28762	3000	8000	16,000	3	0.146
-5	5/16	MS28759 MS28762	3000	7000	14,000	3 3/8	0.177
-6	3/8	MS28759 MS28762	3000	7000	14,000	5	0.271
-8	1/2	MS28759 MS28762	3000	7000	14,000	5 3/4	0.365
-10	3/8	MS28759 MS28762	3000	6000	12,000	6 1/2	0.455
-12	3/4	MS28759 MS28762	3000	6000	12,000	7 3/4	0.568
-16	1	MS28759 MS28762	3000	5000	19,000	9 5/8	0.778

f. Proof Testing of Flexible Hose Assemblies. All field fabricated hose assemblies which have passed the visual inspection shall be proof tested. Hose assemblies drawn from stock shall be inspected for defects such as mishandling damage and proper banding and proof tested if necessary (refer to tables 4-16, 4-17, 4-18, and 4-19).

(1) Test hose assemblies to be used in hydraulic, pneumatic, fuel, oil, and coolant applications using a hydrostatic test unit filled with hydraulic fluid conforming to MIL-H-5606 for MIL-H-6083, lubricating oil MIL-L-6082, or water.

(2) Test hose assemblies to be used in instrument applications using dry, oil-free air or nitrogen, Federal Specifications BB-N-411, Grade A, Type 1.

(3) Connect hose assembly to be tested to hydrostatic test unit, air supply, or nitrogen supply as

**Table 4-16. Operating, Proof, and Burst Test Pressures for MS28741 Medium Pressure Hose Assemblies, using Single Wire Braid Hose, Military Specification MIL-H-8794**

Size	Tube OD (inches)	Hydraulic		Fuel		Oil			Burst pressure (psi)
		Operating pressure (psi)	Proof pressure (psi) <sup>1</sup>	Operating pressure (psi)	Proof pressure (psi) <sup>1</sup>	Operating pressure (psi)	Surge pressure (psi)	Proof pressure (psi) <sup>1</sup>	
-3	3/16	3000	6000	1000	1500	50	400	600	12,000
-4	1/4	3000	6000	1000	1500	50	400	600	12,000
-5	5/16	3000	5000	1000	1500	50	400	600	10,000
-6	3/8	2000	4500	1000	1500	50	400	600	9000
-8	1/2	2000	4000	1000	1500	50	400	600	8000
-10	5/8	1750	3500	1000	1500	50	400	600	7000
-12	3/4	1500	3000	1000	1500	50	400	600	6000
-16	1	800	1600	750	1000	50	400	600	3200
-20	1-1/4	600	1250	500	750	50	400	600	2500
-24	1-1/2	500	1000	250	375	50	400	600	2000
-32	2	350	700	200	300	50	400	600	1400
-40	2-1/2			200	300				1000
-48	3			200	300				800

<sup>1</sup> Hold proof-test pressure for not less than 30 seconds nor more than 5 minutes.

**Table 4-17. Operating, Proof, and Burst Test Pressures for MIL-H-83796 Medium Pressure Hose Assembly, Lightweight**

Hose size	Operating pressure (psi)	Proof pressure (psi) <sup>1 2</sup>	Burst pressure (psi) (min)
-3	1,000	3,000	6,000
-4	1,000	3,000	6,000
-5	1,000	3,000	6,000
-6	1,000	3,000	6,000
-8	1,000	2,500	5,000
-10	1,000	2,500	5,000
-12	1,000	2,000	4,000
-16	750	1,500	3,000
-20	500	1,300	2,000
-24	250	800	1,750
-32	200	600	1,200

<sup>1</sup> Assemblies having aluminum flange fittings shall be pressure tested at the rated proof pressure or 1,500 psig, whichever is less.

<sup>2</sup> Hold proof-test pressure for not less than 30 seconds nor more than 5 minutes

appropriate and apply correct pressure for hose assembly being tested. Proof pressure for MS28759 and MS28762 hose assemblies are shown in table 4-15. Proof pressures for MS28741 hose assemblies are shown table 4-16. Proof pressures for MIL-H-83796 are shown in table 4-17. Proof pressures for MIL-H-83797 hose are shown in table 4-18. Proof pressures for AN6270 hose assemblies are shown in table 4-19. The torque to apply to the swivel nut of the hose assembly when installing on adapter ends is given in table 4-20.

**WARNING**

Hoses to be tested shall be securely restrained to prevent whipping in case the fittings should blow off. Longer hoses should have several restraints. The test is best conducted with hose in an enclosure having a heavy transparent plastic cover which can be fastened closed. Personnel shall wear eye and face protection.

(4) Observe all hose assemblies proof tested with a liquid test medium for leakage from hose or around fittings. Apply proof pressure for not less than 30 seconds and not more than 5 minutes.

**Table 4-18. Operating, Proof, and Burst Test Pressure for MIL-H83797 Medium Pressure Hose**

Hose size	Operating pressure (psi) (max)	Proof pressure (psi) <sup>1,2</sup>	Burst pressure (psi) (min)	Bend radius Inches (min)	Operating temperature (fluid or ambient) <sup>3</sup>
-3	1,000	3,000	6,000	1.75	-65 °F to +250 °F
-4	1,000	3,000	6,000	2.00	-65 °F to +250 °F
-5	1,000	3,000	6,000	2.25	-65 °F to +250 °F
-6	1,000	3,000	6,000	2.50	-65 °F to +250 °F
-8	1,000	2,500	5,000	3.50	-65 °F to +250 °F
-10	1,000	2,500	5,000	4.00	-65 °F to +250 °F
-12	1,000	2,000	4,000	4.50	-65 °F to +250 °F
-16	750	1,500	3,000	5.50	-65 °F to +250 °F
-20	500	1,300	2,000	8.00	-65 °F to +250 °F
-24	250	800	1,750	9.00	-65 °F to +250 °F
-32	200	600	1,200	12.50	-65 °F to +250 °F

<sup>1</sup> Assemblies having aluminum flange fittings shall be pressure tested at the rated proof pressure or 1,500 psig, whichever is less.

<sup>2</sup> Hold proof-test pressure for not less than 30 seconds nor more than 5 minutes.

<sup>3</sup> -54 °C to 121 °C.

**NOTE**

Tighten cap on hose assembly only after all trapped air has bled from line.

(5) Immerse all hose assemblies proof tested with a gas test medium in water and observe for leakage from hose or around fittings. Apply proof pressure for not less than 30 seconds and not more than 5 minutes.

**NOTE**

On hose having a braided cover, do not confuse entrapped air with leakage. Agitate hose assembly under water to remove surface bubbles.

(6) Reject hose assemblies showing evidence of leakage.

**Table 4-19. Operating, Proof, and Burst Test Pressures for AN6270 Hose Assembly using MIL-H-5593 Low Pressure Hose**

Size	Tube outside diameter	Operating pressure	Proof pressure (psi) <sup>1</sup>	Burst pressure (psi)
2	1/8	300	600	2000
3	3/16	250	500	1700
4	1/4	200	400	1250
6	3/8	150	300	1000
8	1/2	150	250	750
10	5/8	150	250	700

<sup>1</sup> Hold proof test pressure for a minimum period of 60 seconds and a maximum of 5 minutes.

**WARNING**

Degreasing solvent, MIL-PRF-680, is combustible and toxic to eyes, skin and respiratory tract. Wear protective gloves and goggles/face shield. Avoid repeated or prolonged contact. Use only in well ventilated areas (or use approved respirator as determined by local safety/industrial hygiene personnel). Keep away from open flame other sources of ignition.

**(7)** After proof test of a hose assembly using hydraulic fluid or oil as a test medium, flush or dip assembly in kerosene, Federal Specification VV-K-211, or degreasing solvent, MIL-PRF-680. Drain assembly and dry using dry compressed air. Drain and dry with dry compressed air hose assemblies tested using water as pressure fluid.

**(8)** Visually inspect instrument hose assemblies which were proof tested using a gas test fluid for evidence of oil or hydraulic fluid on internal surfaces of hose assembly. Clean hoses showing evidence of this contamination as specified in step (7).

**(9)** Install following polyethylene protective plugs in end fittings of hose assemblies that are not to be installed immediately after fabrication: NAS 815-(\*size) A (\*same dash number as fitting). Close openings in flanges (or other special fittings) using pressure sensitive tape or other adequate means to prevent entrance of foreign material.

**g. Identification Tags for Field Fabricated Hose Assemblies.** An identification tag must be affixed to each field fabricated hose assembly.

**(1)** Make tags from aluminum alloy 5052-0, Fed Spec QQ-A-250/8C, 0.020 inch thick, 0.75 inch wide, with the size of the band in accordance with figure 4-42. Mark tags to show data of pressure test, federal stock number or part number, operating pressure, and depot or unit code or name.

**(2)** Mark tags by impression stamping, engraving, or etching.

**TM 1-1500-204-23-2**

(3) Attach tag to hose by passing tab end of tag through slot in opposite end, drawing tag up snug, and bending tab back against hose. Ensure that tag is tight enough on hose so that it will not come off over hose end fittings.

**h. Instructions for Assembly of Medium Pressure, MS28741, and Low Pressure, AN6270, Hose Assemblies.** Medium pressure hose assemblies are fabricated from bulk hose conforming to MIL-H-8794, and fittings conforming to Military Standard MS28740. Low pressure hose assemblies are fabricated from bulk hose conforming to MIL-H-5593 and fittings conforming to Military Standard MS27404.

(1) Inspect hoses as outlined in paragraph 4-5 e(1).

(2) Inspect fittings as outlined in paragraph 4-5 e(2). Aluminum sockets for medium and low pressure hose assemblies can be reused if undamaged.

(3) Assembly equipment required shall correspond to paragraph 4-5 e(3) with the addition of Aeroquip kit, part number S-1051.

(4) Determine hose length as outlined in paragraph 4-5e(4). Do not remove cover after cutting hose to length.

(5) Assemble hose and fittings using following procedure and figure 4-43 steps 1 through 4.

(a) Place socket in a vise. Screw hose into socket counterclockwise until it bottoms; then back off 1/4 turn.

**Table 4-20. Proof Test Torque Values MS Flared Swivel Nut Fittings (Reference and 10064)**

Tubing size O/D inch I/D inch	Hose size Dash fitting size	Torque	
		Minimum	Maximum
3/16	—3	70	100
1/4	—4	70	120
5/16	—5	85	180
3/8	—6	100	250
1/2	—8	210	420
5/8	—10	300	480
3/4	—12	500	850
1	—16z	700	1150
1 1/4	—20z	1000	1300
1 1/2	—24z	1000	1400

**NOTE**

Do not overtighten vise on thin-walled sockets of lightweight fittings. Outer cover of hose is not stripped.

- (b) Tighten nipple and nut on appropriate assembly tool from Aeroquip kit, part number S-1051.
- (c) Lubricate nipple threads and inside of hose liberally using a light minor oil or hydraulic fluid, MIL-H-5606.
- (d) Screw nipple into socket and hose using a wrench on nipple hex nut. Nut must swivel freely when assembly tool is removed. Maximum allowable gap between socket and nut or nipple hex is 1/16 inch.
- (6) Inspect hose assembly for cut inner tube, obstructions, and cleanliness. Inspect for proper gap between nut or nipple hex and socket.

**WARNING**

Make no adjustment, under any condition, of assembly gap or position angle after test and final acceptance of complete hose assembly. Failure to comply may compromise the integrity of the hose assembly.

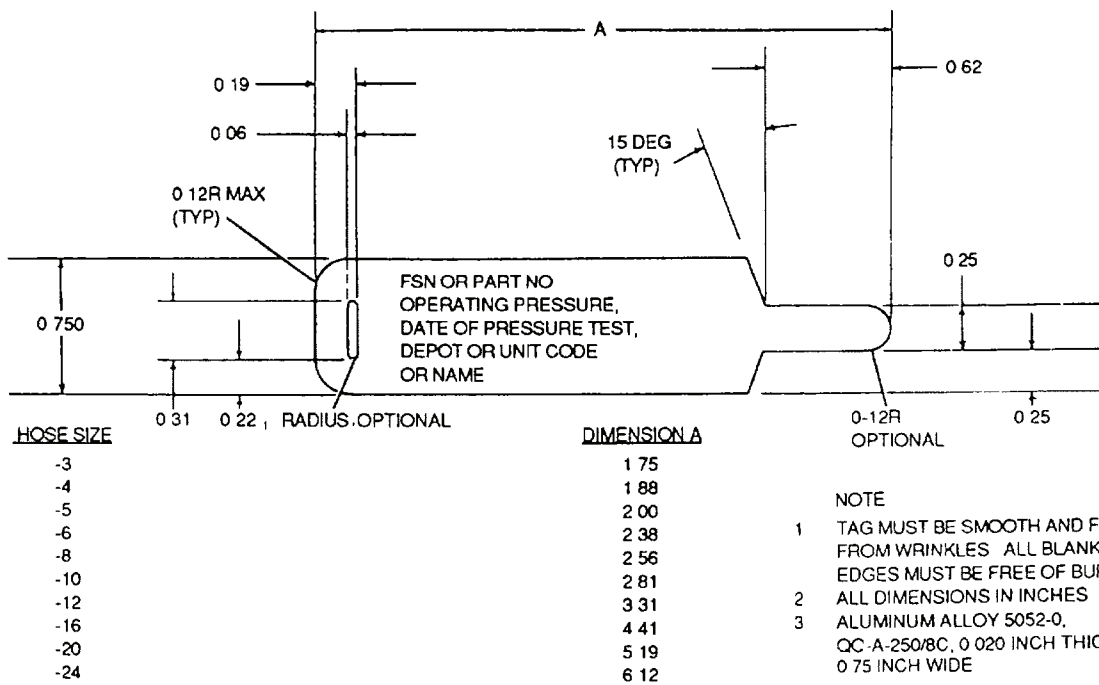
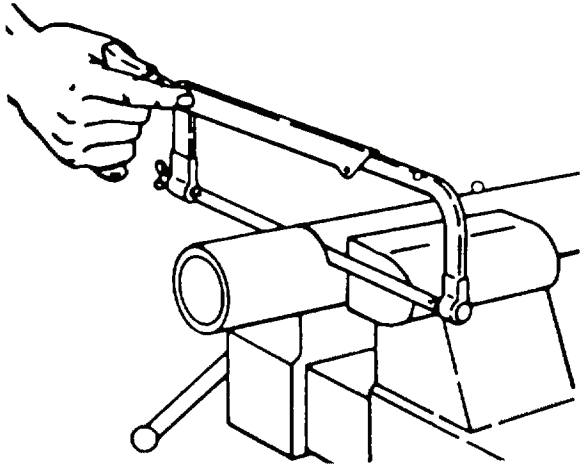


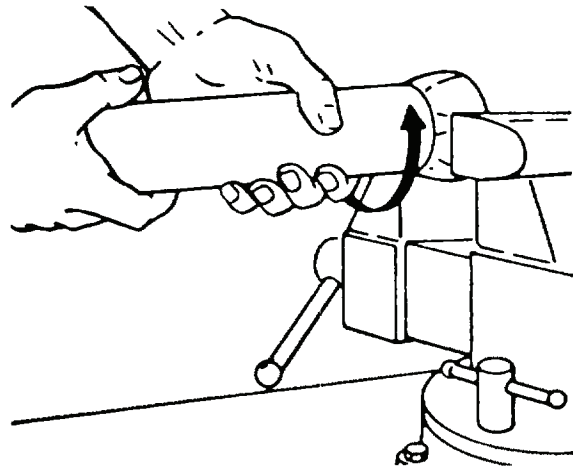
Figure 4-42. Identification Tags for Field Fabricated Hose Assemblies



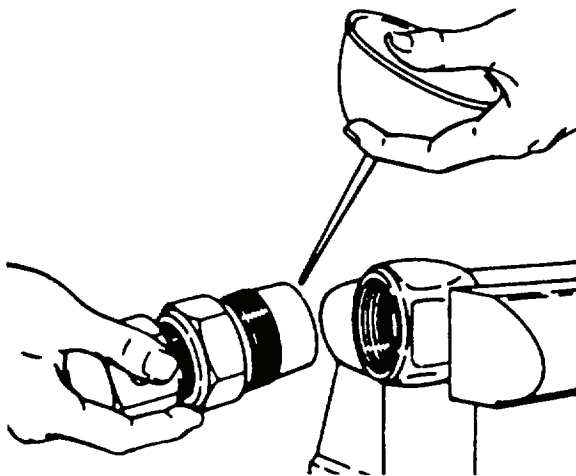
TM 1-1500-204-23-2



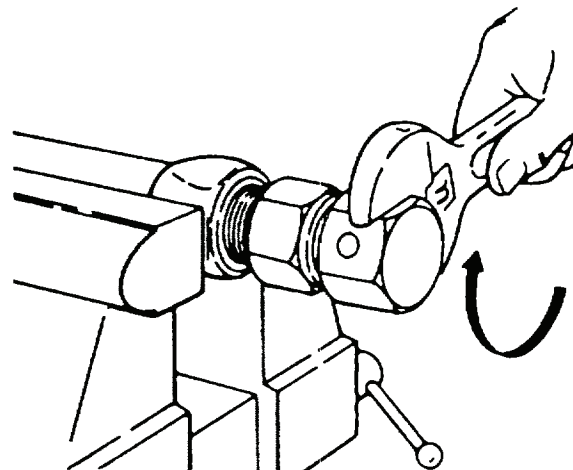
STEP 1



STEP 2



STEP 3



STEP 4

MS030352

Figure 4-43. Assembly of Medium and Low-Pressure Hose Assemblies

(7) Proof test hose assemblies in accordance with 4-5f.

(8) Hose assemblies shall be identified as outlined in 4-5g.

i. **Assembly of Medium-Pressure Tetrafluoroethylene (Teflon) Hose Assemblies.** The following paragraphs provide instructions for identification of bulk Tetrafluoroethylene (commonly known as Teflon and will be referenced as Teflon in this manual) hose conforming to MIL-H-27267 and end fittings conforming to MIL-F-27272 and Drawing MS 27053 through 27089. Specific instructions are provided for inspection, removal, cleaning, disassembly, installation and disposition of Teflon hose assemblies fabricated from bulk hose and end fittings.

(1) Use. Medium pressure Teflon hose assemblies (1,500 psi maximum operating pressure) meeting the dimensions and installed minimum bend radii of table 4-21 are suitable for use in fuel, lubrication, pneumatic, and hydraulic systems Use in other systems shall meet the considerations of paragraph 6.1 of MIL-F-27267 and paragraph 6.1 of MIL-H-27272

**WARNING**

Hose assemblies conforming to MIL-H25579 and hose assemblies conforming to MIL-H-38360 use different hose and fittings. DO NOT interchange components between assemblies. Improper combinations of hose and fittings lead to life endangering failures

**Table 4-21. Tetrafluoroethylene Hose MIL- F-27272 (in Inches)**

Hose size	Hose ID	Tube wall thickness	Hose OD	Bend radius
-3	0.125	0.040	0.250	2
-4	0.188	0.040	0.312	2
-5	0.250	0.040	0.375	2
-6	0.313	0.040	0.446	4
-8	0.406	0.043	0.562	4 5/8
-10	0.500	0.047	0.656	5 1/2
-12	0.625	0.047	0.789	6 1/2
-16Z <sup>1</sup>	0.875	0.047	1 109	7 3/8
-20Z <sup>1</sup>	1.125	0.050	1.359	11
-24Z <sup>1</sup>	1.375	0.070	1.672	14

<sup>1</sup> Z indicates a double layer of wire braid reinforcement

(2) *Identification.* Teflon hose and hose assemblies, and fittings are identified in the following paragraphs.

(a) *Size.* Bulk Teflon hose manufactured to requirement of MIL-H-27267 shall conform to dimensions referenced in table 4-21.

(b) *Appearance and markings.* Hose construction shall be a smooth bore (firm, waxy feeling) inner tube covered with corrosion-resistant steel wire braid. Hose shall be identified by an identification band spaced at 3-foot intervals, marked with specification number and manufacturer's code number as listed in Federal Handbook H4-1.

(c) *Fittings.* All end fitting assemblies conforming to MIL-F-27272 are identified by an attached cardboard disc marked with MS number, manufacturer's part number, name or trademark. All component parts of end fitting assemblies conforming to referenced specification are impression stamped with MS numbers as listed in paragraph 3 of the referenced specification.

### CAUTION

To eliminate the possibility of hose failure by mismatch of similar type fittings, check each item of the assembly carefully to ensure that it conforms to the proper Military Standard (MS) prior to the assembly of the hose.

(d) *Hose assemblies.* Factory fabricated Teflon hose assemblies are identified by a permanently attached metal band marked with MIL-H-25579, operating pressure in psi, assembly part number, date of proof test and hose manufacturer's code number. Locally manufactured or tested Teflon hose assemblies shall be identified by a metal band made from Federal Specification QQ-A-250/8, 5052-0 aluminum alloy, 0.020 inch thick, 0.75 inch wide, in accordance with figure 4-42. The markings on the band may be impression stamped, etched or engraved to include date of pressure test, Federal stock number or part number, operating pressure, and depot or unit code or name. If the pressure test date is more than one year prior to installation in the aircraft or system, the assembly shall be retested and banded prior to installation. Original manufacture date of all retested hoses shall be brought forward onto the new band, if available.

(3) *Handling.* Exercise extreme care when handling bulk Teflon hose and hose assemblies to prevent injury to hands from the wire braid ends and damage to hose due to kinking. Kinking results when hose is bent to a shorter radius than specified in table 4-21 and from twisting during installation. Teflon hose assemblies tend to conform to the shape of installed positions on hot fluid lines; therefore, exercise care in handling and removing these lines to prevent straightening which could result in kinking. A kinked Teflon hose must not be installed since this will result in a failure at point of kink.

(4) *Maintenance Inspection and Replacement Criteria.* Inspect installed Teflon hose assemblies for evidence of deterioration due to wire fatigue or chafing at the specified periods prescribed in the applicable aircraft inspection or maintenance manuals and replace when any of the following conditions are found.

(a) *Leaking.* Static leakage exceeding 1 drop per hour.

(b) *Excessive Wire Damage.* Excessive wire damage consists of 2 or more broken wires in a single plait, or more than 6 broken wires per assembly or per lineal foot whenever assemblies exceed 12 inches in length. Broken wires where kinking is suspected are evidence by sharp dents or twisted wire braid.

### NOTE

Crossed reinforcing or random broken wires is not cause for replacement

(c) *Distortion.* Any evidence of abrasion, kinking, distortion, bulging, or sharp bends.

(d) *Hoses from stock.* Hose assemblies drawn from stock shall be inspected for defects such as mishandling damage and proper banding. Hoses that are suspected to have damage or are not banded will be proof tested and banded.

(e) *Hoses removed from aircraft.* Hose assemblies removed from an aircraft shall be inspected, proof tested, and banded.

(5) *Hose Assemblies and Pump Pressure Lines.* Clean hose assemblies removed from installation for reasons other than cited in paragraph 4-51 (8) and pump pressure lines removed by replacement schedule in

accordance with instructions contained in paragraph 4-5i (9).

(6) *Internal Inspection.* Inspect hose assemblies internally for evidence of tube restriction due to collapse, wire braid puncture, or other damage. Following methods for internal inspection are recommended.

(a) *Straight hose assemblies.* Insert light at one end and inspect by looking through from the opposite end.

(b) *Hose assembly with elbow fitting one end.* Insert flexible inspection light into elbow fitting and examine by looking through the opposite end.

(c) *Hose assemblies with elbow fitting both ends.* Insert flexible inspection light into one end and examine from the opposite end using a dental-type mirror. This procedure is only practical on large size hose assemblies.

(7) *Disassembly.* The hose can be completely disassembled using the following procedures (see figure 4-45).

(a) Place socket in vise and remove nipple assembly by applying wrench to nipple hex (see figure 4-45, detail A).

(b) Remove socket from vise and tap edge of pocket against flat surface to loosen pull socket back onto hose to expose hose end and sleeve insert (see figure 4-45, detail B).

(c) Remove sleeve inserting end of nipple into sleeve internal diameter and gently pry sleeve from inner tube (see figure 4-45, detail C).

(d) Remove socket by pulling or threading socket from hose.

(e) Remove hose fitting on opposite end of assembly.

(f) All removed hose will be condemned and disposed of in accordance with existing regulations.

(8) *Reusability Check.* Use the following procedures to determine whether parts that are removed may be reused.

(a) *Cleaning.* Clean fittings in accordance with paragraph 4-5i (a).

(b) *Finishes.* Examine all fitting details with anodized or plated finish for corrosion damage. Condemn corrosion-damaged parts. Minor scratches are not cause for replacement; however, parts with wrench, vise jaw, or similar marks shall be replaced.

(c) Flanges, sealing faces and/or swivel nuts Inspect these components as follows:

#### CAUTION

Use care when handling flange fittings to prevent damaging the gasket, flange or sealing face of pad or fitting. Failure of equipment could result.

1 Check for wrapping of the flange.

2 Check for damage to the sealing face of the flange fitting. Any damage, nicks, scratches, etc., will be cause of rejection.

3 Check for mutilated threads and evidence of overtightening (This will show up as a belled condition or pulled condition or flared connections and may result in a frozen or tight swiveling nut).

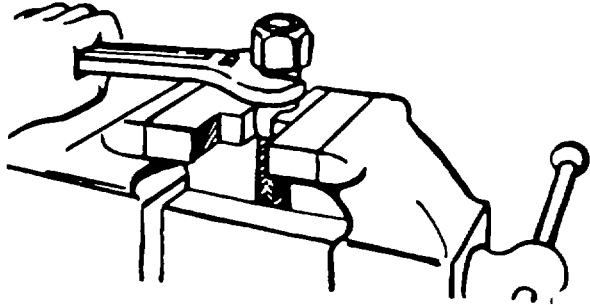
4 Examine for backed-out retaining wires on wired-on swivel nuts. If backed-out wires are found, drive wire back into nut using a drift pin of proper size and ball peen hammer.

(d) *Nipples.* Visually inspect for sealing surface (chamfered area) for damage or galling on stainless nipples (figure 4-46) and for the following defects:

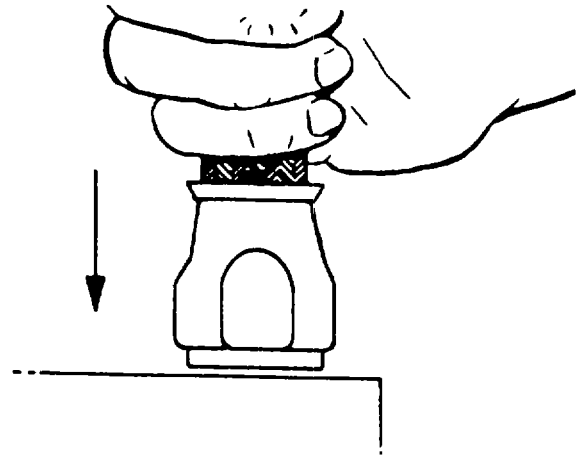
1 Nicks, spiral or longitudinal scratches or scoring which could create an escape passage for fluids.

2 Flare-out or distortion of cone seats resulting from over torquing.

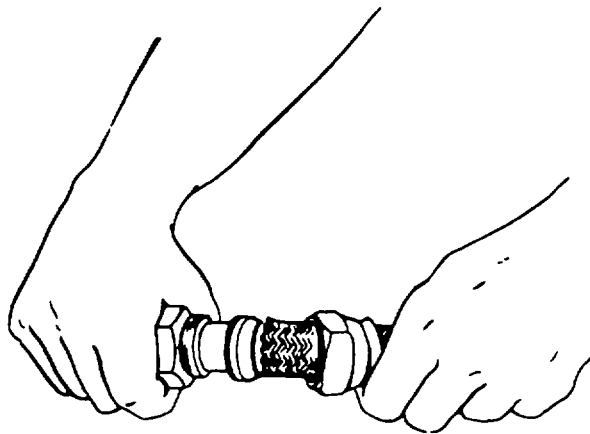
3 Damaged or galled threads (nipple to socket thread) test by threading a new socket of proper size on to the nipple threads.



DETAIL A



DETAIL B



DETAIL C

Figure 4-45. Field Disassembly of Teflon Hose

**4** Test for overtorquing by placing a new sleeve insert of proper size and type for the nipple assembly on the nipple in the normal assembled position. Check for clearance between the sleeve and nipple faces (figure 4-47). Clearance shall exist for good nipple assemblies.

**5** Visually inspect wrench flats on forged-type elbow nipple assemblies for excessive damage.

**(e) Socket.** The socket will be inspected for the following defects:

**1** Visually inspect for distortion or egg-ing and test for damaged threads by threading a new nipple assembly of proper size into the socket threads.

**2** Visually inspect for stress cracks. (Usually appear as longitudinal.)

**(f) Sleeve.** The sleeve will be inspected for the following defects.

**1** Check for out-of-roundness.

**2** Check sealing surface for warpage and damage to mating surface.

**(9) Cleaning.** Clean and degrease hose assemblies and component parts before inspection.

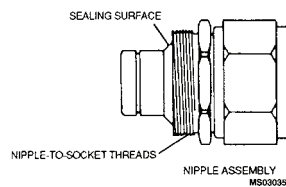
**WARNING**

Degreasing solvent, MIL-PRF-680, is combustible and toxic to eyes, skin and respiratory tract. Wear protective gloves and goggles/face shield. Avoid repeated or prolonged contact. Use only in well ventilated areas (or use approved respirator as determined by local safety/industrial hygiene personnel). Keep away from open flame other sources of ignition.

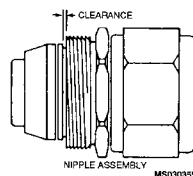
HFE-71DE is toxic to eyes, skin and respiratory tract and decomposes into other hazardous products when exposed to extreme heat. Wear chemical protective gloves and goggles/face shield. Avoid repeated or prolonged contact. Use only in well ventilated areas. If ventilation is not adequate, use approved respirator as determined by local safety/industrial hygiene personnel. Keep away from open flames, welding or other sources of ignition.

**(a) Cleaning fluids.** Any of the following cleaning fluids or other acceptable commercial degreasing solvents may be used for cleaning Teflon hose assemblies.

FLUID	SPECIFICATION
Dry Cleaning Solvent	MIL-PRF-680
Cleaning Compound, Solvent	HFE 71DE



**Figure 4-46. Nipple Assembly Surface**



**Figure 4-47. Nipple Assembly Clearance**

TM 1-1500-204-23-2

**(b) Hose assemblies.** Flush or dip hose assemblies in cleaning fluid and brush, if necessary, to dislodge deposits.

**CAUTION**

Do not wire-brush dry tube surfaces. Failure to comply will result in destruction of the hose assembly.

**WARNING**

Degreasing solvent, MIL-PRF-680, is combustible and toxic to eyes, skin and respiratory tract. Wear protective gloves and goggles/face shield. Avoid repeated or prolonged contact. Use only in well ventilated areas (or use approved respirator as determined by local safety/industrial hygiene personnel). Keep away from open flame other sources of ignition.

**(c) Component parts.** Thoroughly clean all component parts by dipping and brushing where necessary in degreasing solvent, MIL-PRF-680.

**(d) Cleaning hose assemblies after proof test.** Flush or dip hose assemblies in cleaning fluid and drain.

**(10) Assembly procedures.** The following steps shall be followed when fabricating hose assemblies from new or salvaged components (see figure 4-48).

**(a) Tools required.** Use common hand tools, i.e., wrench, hacksaw, protractor, vise and hydraulic test stand.

**WARNING**

Hose assemblies conforming to MIL-H-25579 and hose assemblies conforming to MIL-H-38360 use different hose and fittings. DO NOT interchange components between assemblies. Improper combinations of hose and fittings lead to life endangering failures.

**CAUTION**

End fittings shall not be installed on used aircraft hose MIL-H-27267 and/or MIL-H-25579. Failure to comply may result in compromise of the integrity of the hose assembly.

**NOTE**

Assembly mandrels are not needed for hand assembly of fittings.

**(b) Hose length.** Determine hose length by subtracting cutoff factor (table 4-22) from desired hose assembly length. Cut hose squarely. To prevent a flare-out of the wire end during the cutoff operation, (figure 4-48, detail A) a piece of masking tape can be wrapped around the hose at the point. After the hose is cut, and before proceeding with the assembly, the tape must be removed.

**(c) Install sockets.** To facilitate assembly on sizes up to -8, place two sockets skirt-to-skirt in vise (figure 4-48, detail B) and work hose through sockets with a pushing, twisting motion. Insert neck down to facilitate assembly.

**(d) Size tube and flare braid.** Place nipple in vise. Push hose onto the nipple to size tube ID and to aid in separating the wire braid from the tube (figure 4-48, detail B). Remove hose from the nipple.

**(e) Install sleeve.** Carefully insert sleeve between braid and tube OD using caution that no wires are trapped between the sleeve and tube OD. Complete positioning by pushing end of sleeve against flat surface until tube bottoms against shoulder sleeve ID (figure 4-48 detail C). Visually inspect to see that tube end is bottomed against sleeve shoulder and that no wires are trapped under sleeve.

**(f) Sizing tube to sleeve.** Size tube to sleeve by pushing nose over the nipple until the sleeve bottoms against the nipple chamber. Remove and recheck to be certain that the sleeve is still properly positioned. Again push hose over the nipple and bottom sleeve against the nipple chamfer.

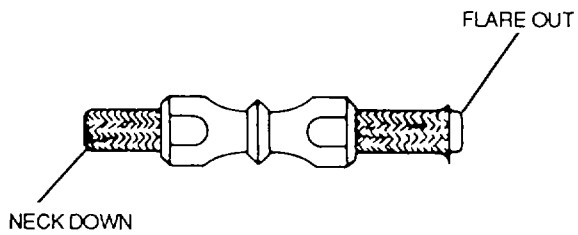
**NOTE**

No lubrication is needed, as components are permanently dryfilm lubricated.

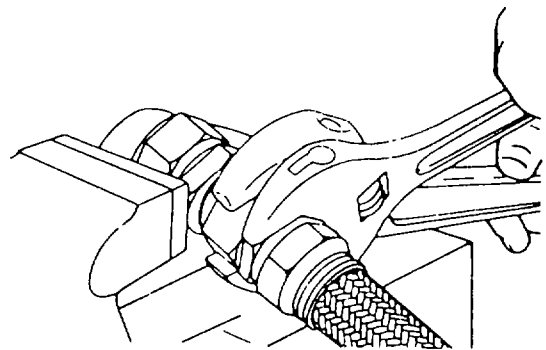
**(g) Engage socket and tighten.** Slide socket forward and engage threads by hand. Remove assembly from vise and regrip by socket. Using a wrench on nipple hex, tighten to a gap of 1/32 inch nominal (gap may vary from 0.025 to 0.045 inch) (figure 4-48, details D and E).



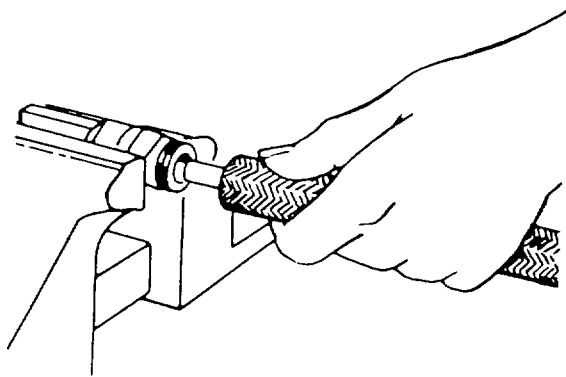




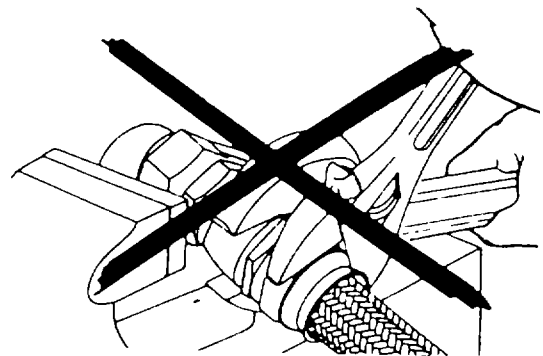
DETAIL A



DO — PLACE WRENCH ON NIPPLE HEX TO HOLD LINE WHILE LOOSENING SWIVEL NUT

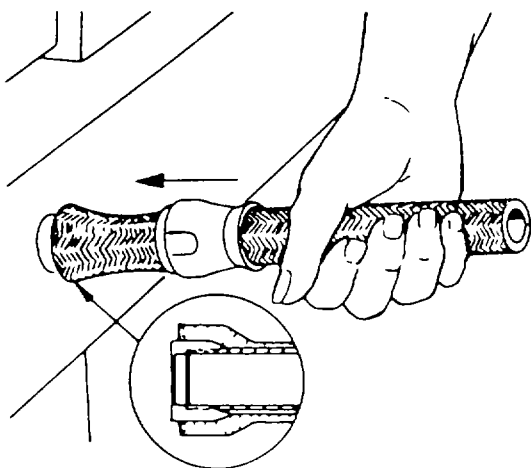


DETAIL B

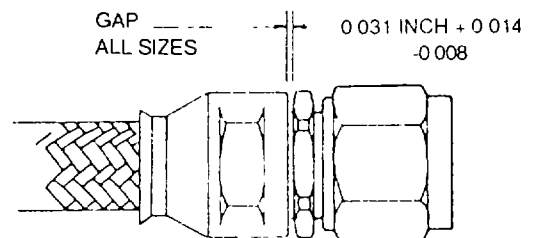


DONT — PLACE WRENCH ON SOCKET FLAT TO HOLD LINE WHILE LOOSENING SWIVEL NUT

DETAIL D

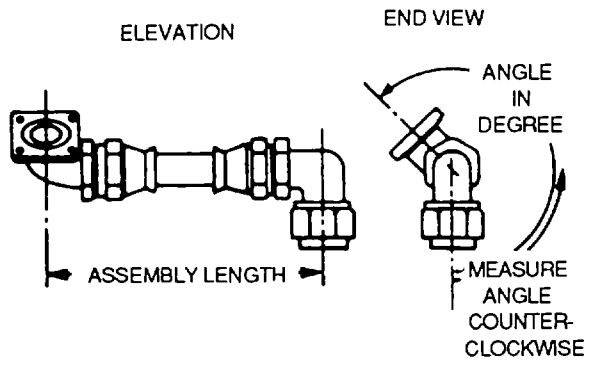


DETAIL C

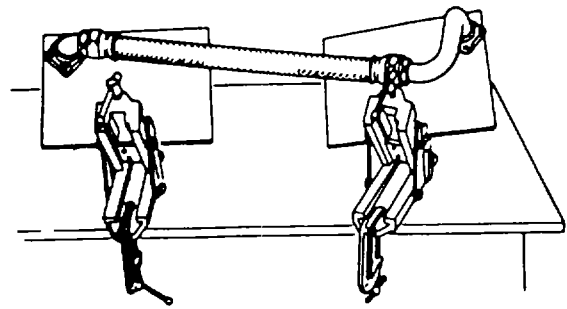


DETAIL E

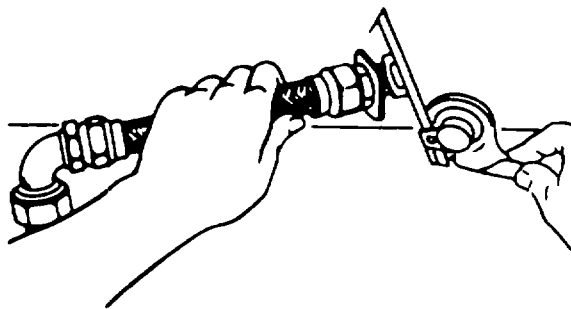
Figure 4-48. Medium-Pressure Teflon Hose Assembly Procedure (Sheet 1 of 3)



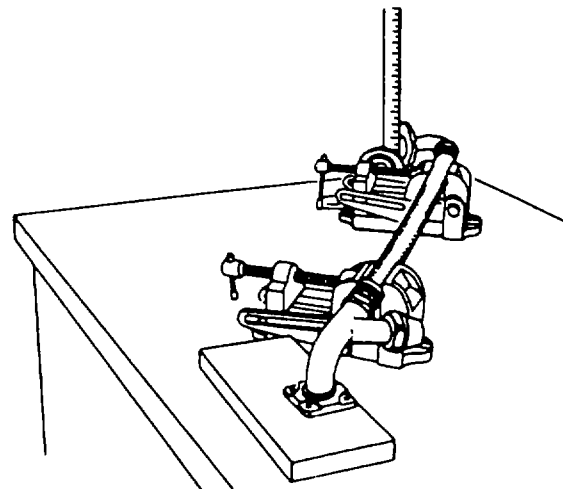
DETAIL F



DETAIL H

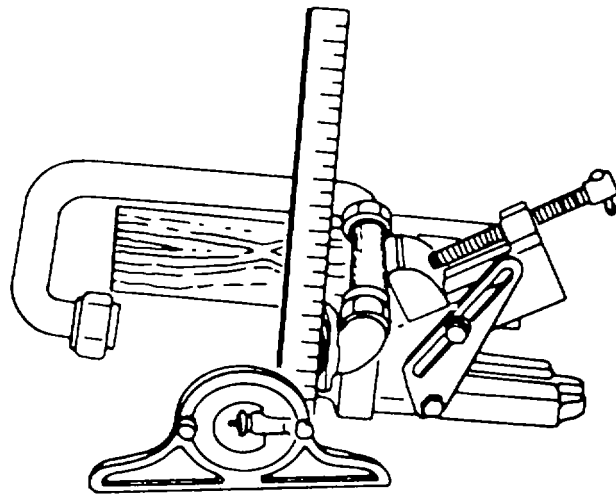


DETAIL G

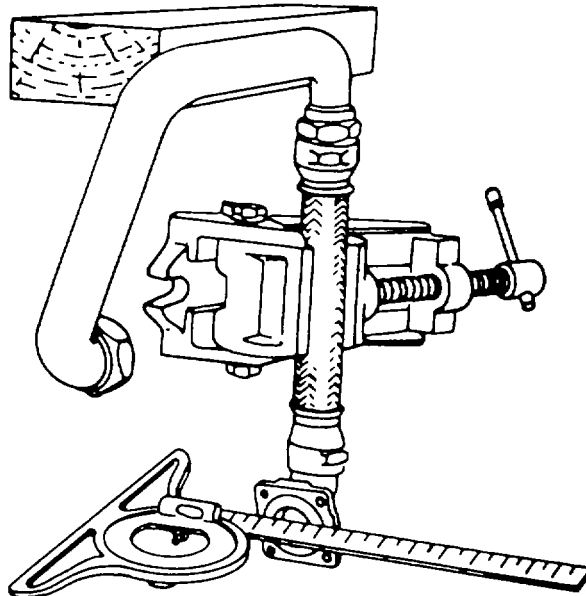


DETAIL I

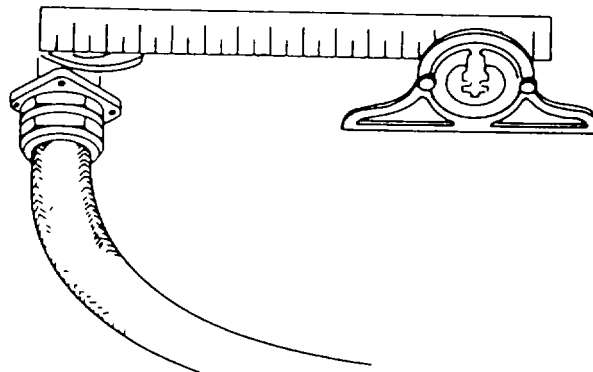
Figure 4-48. Medium-Pressure Teflon Hose Assembly Procedure (Sheet 2 of 3)



DETAIL J



DETAIL K



DETAIL L

Figure 4-48. Medium-Pressure Teflon Hose Assembly Procedure (Sheet 3 of 3)

**NOTE**

If fitting gap after assembly is less than 0.025 inch, back socket off until it rotates freely on hose, then repeat paragraph (g).

(h) *Final assembly.* Install opposite hose end fitting using paragraphs (d) through (g) above.

**NOTE**

If both fittings are elbow fittings, the relative position angle (index angle between fittings) must be set before tightening to final gap.

(i) *Proof test.* Proof test hose assembly as described in proof test procedures, paragraph 4-5i (12).

(11) *Setting position angle on elbow hose assemblies.* Two methods may be used to establish the proper position angle of fittings when an elbow fitting is used on both ends.

(a) *Method for standard elbow fittings.* Standard elbow fittings are positioned as follows.

1 Establish base position Base position may be the top of a workbench or an elbow mounted in a vise.

2 Position and measure position angle See figure 4-48, details F and G for proper reading of position angles. While opposite fitting is still loose enough to swivel by hand, turn to required angle and measure using an adjustable protractor or other suitable angle measuring advice.

3 Complete fitting assembly by mounting in vise to hold elbow or hose from turning while tightening to required gap (see figure 4-48, detail H).

**Table 4-22. Teflon Hose Cutoff Factors (in Inches)**

Size	MS swivel or fittings			MS flange fittings		
	A	B	C	D	E	F
	ST	45 degrees	90 degrees	ST	45 degrees	90 degrees
—3	1.40	2.16	1.72			
—4	1.48	2.36	1.82			
—5	1.54	2.44	1.94			
—6	1.62	2.58	2.06			
—8	1.86	3.58	2.62	2.54	2.50	2.42
—10	2.10	3.16	2.82	2.70	2.84	2.82
—12	2.26	4.10	3.84	3.10	3.89	3.84
—16Z	2.60	4.28	4.10	3.22	3.96	4.10
—20Z	2.88	4.84	4.68	3.38	4.44	4.68

4 Recheck position angle to be sure position angle has not changed.

(b) *Method for special elbow bends and/or preformed hose.* Special elbows and preformed hose are positioned as follows.

1 Assemble one end of the hose assembly as described above.

2 Determine required angles. Required angles may be obtained from the hose assembly part number by comparison with a known good hose assembly or with an assembly mocked-up on the installation. Preferably the assembly to be repaired should be set up on a flat surface, vises and parallels set and clamped, and required angles set on protractor before the assembly is disassembled. See figure 4-48, details I, J, and K for this setup.

3 Establish base positions and check angle, drop dimension and assembly length. Angle vises shall be tilted so that the flange mounting plates are parallel to the face of the flange and the flange mounting holes lined up with the bolt holes already tapped in the mounting plates. Any necessary spacing with parallel bars shall be done at this time. When this procedure is followed properly, the result will be a fixture with the proper angles, drop dimensions, and lengths established. See figure 4-48, details I, J, K, and L for this setup.

4 Complete fitting assembly by mounting in vise to hold elbow or hose from turning while tightening to required gap.

5 Recheck position angle to be sure position angle has not changed.

(12) *Proof test procedures.* Proof test all hose assemblies after assembly for a minimum period of 30 seconds and maximum period of 5 minutes, using Tester, Hose Assembly, Part Number 78344, FSN 4920-00-855-9035.

(a) *Proof test pressures.* Recommended proof test pressures are listed in table 4-23.

#### NOTE

Proof pressures for flange fittings are reduced to avoid possible distortion of the flange and shoulder by exceeding design pressure limitations for flange fittings.

(b) *Proof test medium.* Proof test medium shall be hydraulic oil, MIL-H-5606.

(c) *Cleaning.* Clean and drain hose assembly after proof test as directed in paragraph 4-5i (9).

#### NOTE

Application of an identifying mark such as a paint dot, indicating satisfactory proof test, is recommended.

(d) *Capping.* Cap or plug all hose assemblies to ensure cleanliness.

(13) *Installation.* The following procedures and precautions will be followed when installing Teflon hose assemblies (see figure 4-49).

#### CAUTION

Do not place wrench on socket of hose fitting when installing hose assembly. Failure to comply will compromise the strength and integrity of the union between the hose and fitting.

(a) *Route and securely clamp.* Teflon hose assemblies to avoid abrasion, and particularly to prevent kinking where flexing occurs.

(b) Eliminate chafing against structure, moving parts, or other assemblies by clamping and use of chafing guard if necessary.

(c) Support Teflon hose assemblies by clamping every 24 inches. Closer support is preferred if possible. Support flexible hose assemblies by clamping so that they cannot cause deflection of rigid connecting assemblies. Support clamps shall not restrict travel or cause hose to be subjected to tension, torsion, compression or shear stress during flexing cycles. Select proper size support clamps as indicated in table 4-24.

**Table 4-23. Proof Test Pressures, Medium-Pressure Teflon Hose Assemblies**

Hot size	Swivel end fittings	Flanged fittings
—3	3000 psi	
—4	3000	
—5	3000	
—6	3000	
—8	3000	1500psi
—10	3000	1500
—12	2000	1500
—16Z	2500	1250
—20Z	2000	1000
—24Z	2000	1000

(d) When installation of Teflon hose assemblies requires bending, the radius shall not be less than minimum bend indicated in table 4-21. A larger radius than minimum allowed is preferred.

(e) The following precaution in flexing installations will help prevent kinking. Bend hose in the same planes as movement to avoid twisting.

(f) Hose flexing in two directions shall be clamped at the point where hose changes planes. This has the effect of dividing the hose into sections, each in one plane.

(g) Install flared swivel connections according to torque values shown in table 4-25.

(14) *Storage of hose and assemblies.* Teflon hoses will be stored in accordance with the following paragraphs.

(a) *Age limitations.* Teflon hose has a nearly unlimited life in storage. No age limitations have been established on medium pressure hose, MIL-H-27267, and high pressure hose, MIL-H-38360.

(b) *Hose.* Tape ends of hose to prevent wire flareout. Storage in a straight position is preferred. If coiling is necessary, large loose coils are preferred.

**CAUTION**

Under no circumstances shall hose be piled to a height which could result in damage to the lower sections. This caution applies to hose in cartons as well as to unpackaged hose.

(c) *Hose assemblies.* Cap or plug ends of all hose assemblies during storage with polyethylene protective plugs conforming to National Aerospace Standard (NAS) 815 or to paragraph 4-5k.

(15) *Hose disposition.* Condemn all hose or fittings which are scrapped on tear-down, or hose and hose assembly in supply which become damaged, deteriorated, or otherwise unsatisfactory for use on aircraft, missiles, and related accessories in accordance with existing disposition instructions.

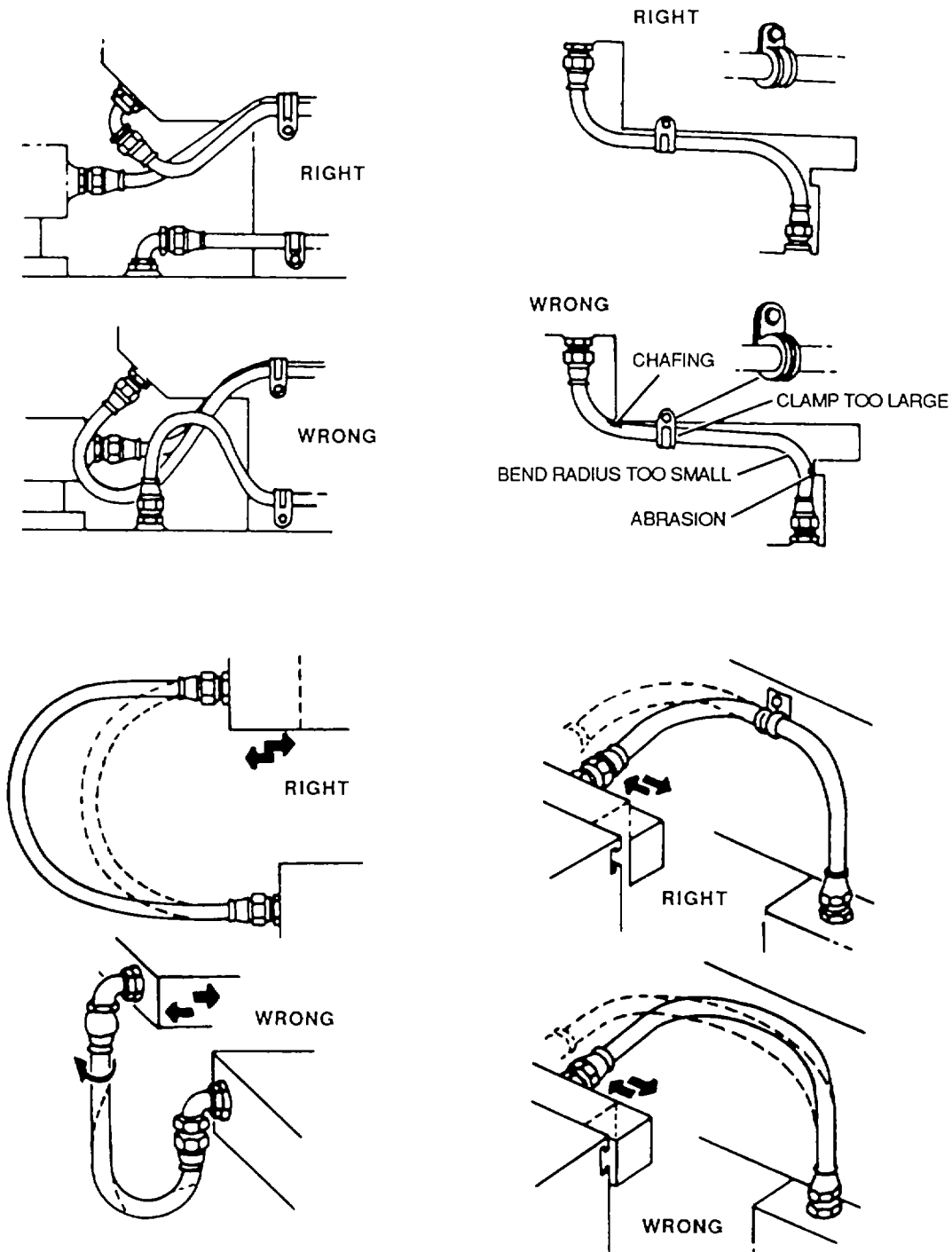


Figure 4-49. Teflon Hose Installation Procedures, Right and Wrong



**Table 4-24. Support Clamp Sizes (For Use with MIL-H-27267 Hose of Teflon)**

<b>Hose Size</b>	-3	-4	-5	-6	-8	-10	-12	-16Z	-20Z	-24Z
<b>Clamp Size (MS1 91 9)</b>	5	6	7	8	10	11	13	18	22	27

**Table 4-25. Installation Torque Values MS Flared Swivel**

Nut fittings (reference AND10064)			
Fitting Size	Torque (In-lb)		
	Min	Max	
—3	70	100	
—4	70	120	
—5	85	180	
—6	100	250	
—8	210	420	
—10	300	480	
—12	500	850	
—16Z	700	1150	
—20Z	1000	1300	
—24Z	1000	1400	

*j* Assembly of High-Pressure Tetrafluoroethylene (Teflon) Hose Assemblies. The following paragraphs provide instructions for identification of bulk Tetrafluoroethylene (commonly known as Teflon and will be referenced as Teflon in this manual) hose conforming to AS-604A and MIL-H-38360 and end fittings conforming to Drawings MS 33514, MS 33656 and NAS 1760. Specific instructions are provided for inspection, removal, cleaning, disassembly, installation and disposition of Teflon hose assemblies fabricated from bulk hose and end fittings.

(1) *Use. High-pressure.* Teflon hose assemblies (3,000 PSI maximum operating pressure) meeting the dimensions and installed minimum band radii are suitable for use in pneumatic and hydraulic systems. Use in other systems shall meet the considerations of MIL-H-38360 and Military Standards 27363 through 27374, 33514, 33656 and National Aerospace Standards 1760.

(2) Identification Hoses and components can be identified by the following guidelines.

(a) *Hose.* Bulk Teflon manufactured to requirements of MIL-H-38360 shall conform to dimensions referenced in table 4-26. Hose construction shall be a smooth bore (firm, waxy feeling) inner tube covered with corrosion resistant steel wire braid. Hose shall be identified by an identification band spaced at 3-foot intervals, marked with specification number and manufacturer's code number as listed in Cataloging Handbook H4/48.

(b) *Fittings.* All end fitting assemblies conforming to Military Standards (MS) 33514, 33656 and National Aerospace Standards (NAS) 1760 are identified by an attached cardboard disc marked with MS number, manufacturer's part number, name or trademark. All component parts of end fitting assemblies conforming to reference specification are impression stamped with the appropriate specification number.

**CAUTION**

To eliminate the possibility of hose failure by mismatch of similar type fittings, all MS and NAS numbers shall be verified by supervisory and/or quality control personnel to ensure that the MS or NAS number is correct for that particular application.

(c) *Hose assemblies identification.* The following paragraph describe how to identify factory fabricated, locally manufactured or tested Teflon hose assemblies.

1. Factory fabricated. Factory fabricated Teflon hose assemblies are identified by a permanently attached metal band marked with the appropriate specification, operation pressure in psi, assembly part number, date of proof test, and hose manufacturer's code number

2. Locally manufactured or tested. Locally manufactured or tested Teflon hose assemblies shall be identified by a metal band made from Federal Specification QQ-A-250/8C, 5052-0 aluminum alloy, 0.020 inch thick, 0.75 inch wide, in accordance with figure 4-42. The markings on the band may be impression stamped, etched or engraved to include date of pressure test, Federal Stock Number of part number, operating pressure, and depot or unit code or name. If the pressure test date is more than one year prior to installation in the aircraft or system, the assembly shall be retested and banded prior to installation. Original manufacture date of all retested hoses shall be brought forward on to the new band, if available.

(3) *Handling and inspection.* Refer to paragraph 4-5i (3), (4).

(4) *Disassembly.* Refer to paragraph 4-5i (7).

(5) *Cleaning.* Refer to paragraph 4-5i (9).

(6) *Assembly.* High-pressure Teflon hose can be assembled using the procedures provided in the following paragraphs.

(a) *Tools required.* Use common hand tools, i.e., wrench, hacksaw, protractor, vise, and hydraulic test stand.

**WARNING**

Hose assemblies conforming to MIL-H-25579 and hose assemblies conforming to MIL-H-38360 use different hose and fittings. DO NOT interchange components between assemblies. Improper combinations of hose and fittings lead to life endangering failures.

**CAUTION**

Used end fittings and aircraft hose shall not be reused in fabrication of MIL-H-38360, Aircraft Hose. Failure to comply will compromise the integrity of assembled hoses.

(b) *Assembly procedure for high pressure Teflon hose (MIL-H-36360).* See figure 4-50. The following steps shall be followed when fabricating hose assemblies from new components.

1. Hose length. Determine hose cutoff length by subtracting fitting cutoff factor from the hose assembly length or by calculating the length from the information shown on the hose assembly drawing (see table 4-27). The cutoff length may also be determined by measuring the used length of hose being replaced. Cut hose squarely. A hose cutoff wheel is recommended. However, a fine tooth hacksaw may be used. To prevent a flare-out of the wire end during the cutoff operations, wrap tape around the hose at the cutoff point. After the hose is cut, and just prior to installing sockets, the tape must be removed (see figure 4-50, detail A).

2. Install sockets. Place two sockets skirt-to-skirt in a vise and work hose through sockets with a twisting, pushing motion. Inserting sockets over neck down end of hose will facilitate assembly. On extra long assemblies, the sockets may be installed on each end of the hose individually (see figure 4-50, detail B),

3. Size tube and flare braid. Place nipple hex in vise. Push one end of hose onto the nipple and work gently in circular motion to aid in separating the wire braid from the tube. Remove hose from nipple (see figure 4-50, detail C)

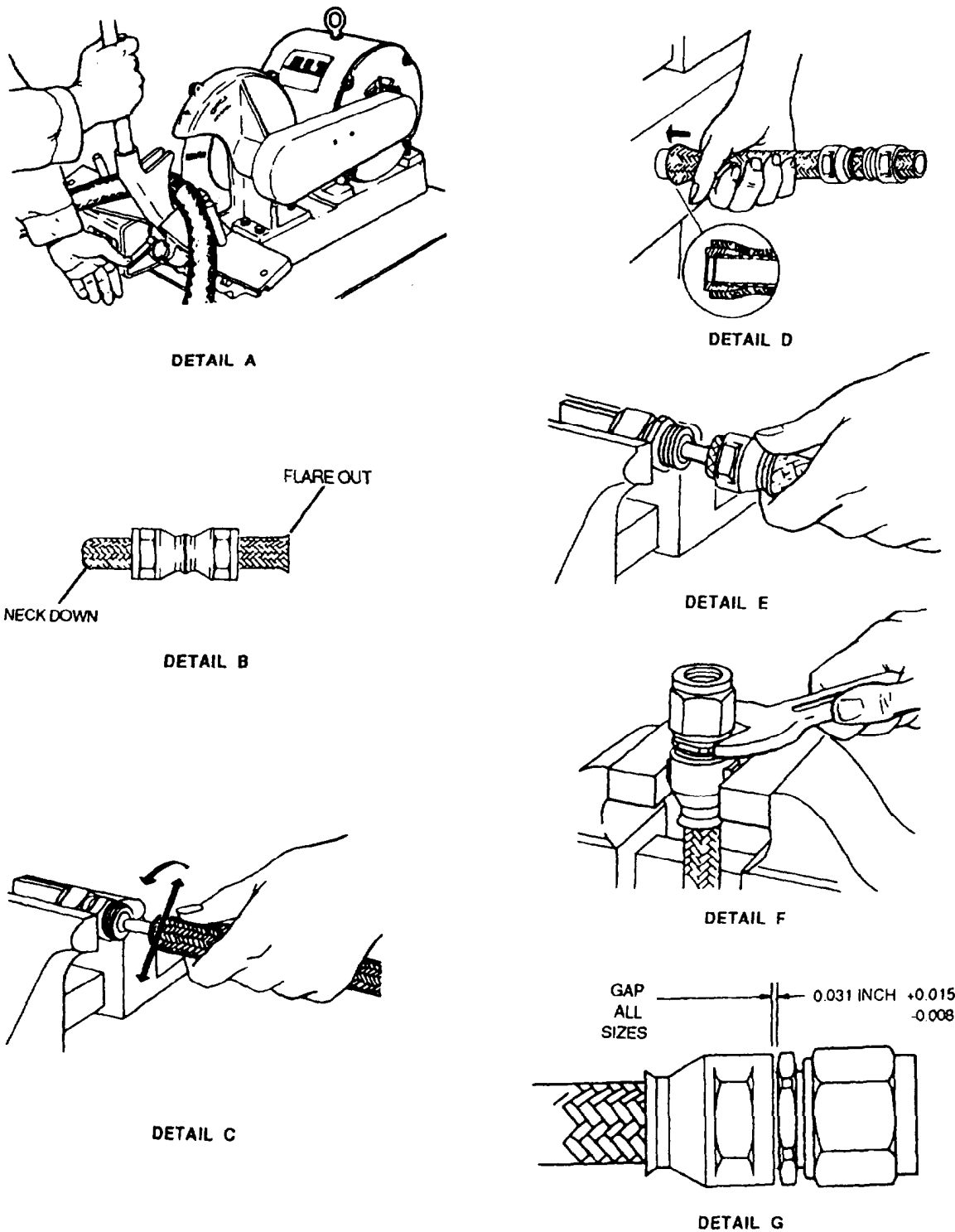


Figure 4-50. Field Assembly of High-Pressure Teflon Hose, MIL-H-38360.

**Table 4-26. Tetrafiouroethylene Hose MIL-H-38360 (In Inches)**

Hose size	Hose ID	Tube wall thickness	Hose OD	Bend radius
—4	0.212	0.035	0.390	3.000
—6	0.298	0.035	0.485	5.000
—8	0.391	0.045	0.605	5.750
—10	0.485	0.045	0.720	6.500
—12	0.602	0.045	0.884	7.750
—16	0.852	0.045	1.280	9.625
—20	1.101	0.045	—	12.000

4 *Install sleeve.* Carefully insert sleeve between braid and tube OD, using caution that no wires are trapped between the sleeve and tube OD. Complete positioning by pushing end of sleeve against flat surface until tube bottoms against shoulder in sleeve ID. Visually inspect to see that tube end is bottomed against sleeve shoulder and that no wires are trapped under sleeve (see figure 4-50, detail D).

5 *Size tube to sleeve.* Size tube to sleeve by pushing hose onto the nipple until the sleeve bottoms against the nipple chamfer. Remove and recheck to be certain that the sleeve is still properly positioned. Again push hose onto the nipple until the sleeve is bottomed against the nipple chamfer (see figure 4-50, detail E).

**NOTE**

When assembling new fittings, no lubrication is needed because component parts are dryfilm lubricated at the time of manufacture.

6 *Engage socket and tighten.* Slide socket forward and thread onto nipple by hand. (Special tool required for -12 size. ). Remove assembly and place the socket in vise. Using a wrench on the nipple hex, tighten to a gap of 1/32 inch nominal for all sizes. (Gap may vary from 0.023 to 0.046 inch) (see figure 4-50, detail F). Z Measure gap. Gap is measured between socket and nipple hex, as shown in figure 4-50, detail G.

**NOTE**

Standard elbow fittings may be assembled using the procedure above. Special elbows may be assembled by holding the nipple in a vise.

(c) *Setting position angle on elbow hose assemblies.* Refer to paragraph 4-51 (11).

(7) *Cleaning, inspection, and proof testing.* Hose assemblies are cleaned, inspected, and proof tested as described in the following paragraphs.

**NOTE**

Proof test shall be verified by quality control personnel.

(a) *Cleaning.* Clean hose after cutting to length. Be sure all cutting residue is dislodged. After assembly, clean each hose assembly internally using clean, dry compressed air.

**Table 4-27. Hose Cutoff Factors, MIL-H-38360 Hose (In Inches)**

Size	MS swivel or fittings			MS flange fittings		
	A	B	C	A	B	C
	ST	45 degrees	90 degrees	ST	45 degrees	90 degrees
—4	.92	2.06	1.69	1.15	2.19	1.69
—6	1.04	32.35	1.92	1.26	2.50	1.92
—8	1.16	2.61	2.10	1.46	2.81	2.10
—10	1.21	2.74	2.26	1.50	2.94	2.26
—12	1.27	3.06	2.40	1.71	3.35	2.40
—16	1.33	3.84	2.74	1.92	3.76	2.74

**Table 4-28. Proof Test Pressures, High-Pressures Teflon Hose Assemblies**

Hose size	Swivel end fittings
—3	6000 PSI
—4	6000 PSI
—5	6000 PSI
—6	6000 PSI
—8	6000 PSI
—10	6000 PSI
—12	6000 PSI
—16	6000 PSI
—20	6000 PSI

(b) *Inspect.* Inspect hose assembly internally for cut or bulged inner tube, obstructions and cleanliness. Examine hose assemblies and fittings for hose push-out. Inspect for proper gap between nut and socket or hex and socket Nuts should swivel freely.

(c) *Proof pressure test.* All hose assemblies shall be pressure tested to the values specified in Table 4-28 for not less than 30 seconds and not more than 5 minutes. Test with hydraulic oil conforming to MIL-H-5606 for tests conducted at room temperature. Any evidence of leakage from hose or fittings or any other evidence of malfunction shall constitute failure.

**NOTE**

Inspect all hose with fire sleeving after proof testing for fluid contamination. Contaminated sleeving will be replaced.

(8) *Installation of hose assembly.* Refer to paragraph 4-51 (13). Refer to table 4-29 for support clamp sizes.

(9) *Storage of hose and assemblies.* Refer to paragraph 4-5i (14).

(10) *Hose disposition.* Refer to paragraph 4-51 (15).

(11) *DELETE*

k. *Self-Sealing.* Hose for Aromatic Fuel MIL-H-7061. Instructions for the use of self-sealing hose are contained in the following paragraphs.

**Table 4-29. Support Clamp Sizes (For use with MIL-H-38360 Hose of Teflon)**

Hose Size	-3	-4	-5	-6	-8	-10	-12	-16	-20
<b>Clamp Size (MS21919)</b>	5	7	7	9	11	12	14	18	22

(1) *Identification.* Self-sealing aircraft hose or hose assemblies can be readily identified as to age and manufacturer by code markings which are stencilled along the full length of the hose, at least 12 inches apart, placed immediately adjacent to the color line (see figure 4-38). The cover of the hose will have a red stripe along its length parallel to the longitudinal axis. The stripe maybe gum inlaid or gasoline and oil-resistant lacquer.

(2) *Inspection.* Self-sealing hose and hose assemblies will be free from defects such as cracks, cuts, breaks, blisters, looseness exposed braid, and restricted inside diameter. Surface irregularities such as mold marks, laps, or air bubbles, as distinguished from cracks or cuts, shall not be cause for rejection.

(a) *Deterioration.* Inspect hose as outlined n paragraph 4-5c (l)

(b) *Fittings.* Inspect hose fittings as outlined paragraph 4-5e (2).

(3) *Design and construction.* Hose shall be constructed of a seamless, smooth-bore, compounded inner tube, a reinforcement, and an outer compounded cover. The hose shall be constructed as to permit ready assembly with standard hose fitting connection ends, tubing ends, pipe threaded adapters, and hose clamps, conforming to AN 840, MS28752, MS28753, MS28754, MS28755, MS28756, MS33660, MS33658, and MIL-C-6985, and Aeroquip kit part number S-1051.

(4) *Hose assembly.* Assemble hose as outlined in paragraph 4-5d.

(a) *Hose length.* Determine correct hose length as outlined In paragraph 4-5d (4).

(b) *Assembly.* Assemble hose and fittings, as outlined in paragraph 4-5h (5) and figure 4-43. (c) *Inspection.* Inspect hose assembly Internally for cut or bulged inner tube (refer to table 4-30), obstructions, and cleanliness. Inspect for proper gap between nut and nipple hex and socket

(5) *Identification tag.* Hose assembly shall be identified as outlined In paragraph 4-5g.

(6) *Proof testing of hose assembly.* All field-fabricated hose assemblies which have passed the visual inspection shall be proof tested. Hose assemblies drawn from stock shall be inspected for defects such as mishandling damage and proper banding, and proof tested if necessary. Proof testing procedures are:

(a) Connect hose assembly to be tested to hydrostatic test unit, air supply, or nitrogen supply, as appropriate, and apply correct pressure for hose assembly being tested. Proof pressure for MIL-H-706 I hose assembly Is shown in table 4-3 1.

(b) Observe hose assemblies proof tested with a liquid test medium for leakage from hose or around fittings. Apply proof pressure for not less than 30 seconds and not more than 5 minutes.

**NOTE**

Tighten cap on hose assembly only after all trapped air has bled from the line.

(c) Immerse hose assemblies proof tested with a gas test medium in water, and observe for leakage from hose or around fittings. Apply proof pressure for not less than 30 seconds and not more than 5 minutes.

(d) Reject hose assemblies showing evidence of leakage.

**Table 4-30. Coupling Bulge, MIL-H-7061 Hose Assembly**

Hose Size	Minimum bulge diameter	Hose size	Minimum bulge diameter
-3	0.094	-10	0.469
-4	0.141	-12	0.563
-5	0.203	-16	0.750
-6	0.266	-20	1.000
-8	0.344	-24	1.250
		-32	1.625

**Table 4-31. Proof Test and Operating Pressure (psi) for MIL-H-7061**

Hose size	Hose ID			Hose OD		Hose Wall Thickness		Max. oper. press. (psi)	Proof press. (psi)	Min. burst press. (psi)
	Nom.	High	Low	High	Low	High	Low			
-10	5/8	.640	.609	1.328	1.234	.344	.313	100	200	400
-12	3/4	.781	.719	1.453	1.359	.348	.308	100	200	400
-16	1	1.031	.969	1.703	1.609	.348	.309	100	200	400
-20	1 1/4	1.281	1.219	2.031	1.906	.383	.336	75	125	250
-24	1 1/2	1.531	1.469	2.281	2.156	.383	.336	75	125	250
-32	2	2.031	1.969	2.781	2.656	.383	.336	45	75	150
-40	2 1/2	2.531	2.469	3.281	3.156	.383	.336	45	75	150
-48	3	3.031	2.969	3.968	3.844	.476	.430	45	60	150

**NOTE**

Hose wall thickness is ID to hose OD. The wall thickness must be held; however, the hose cannot exceed specified ID and dimensions.

**WARNING**

Degreasing solvent, MIL-PRF-680, is combustible and toxic to eyes, skin and respiratory tract. Wear protective gloves and goggles/face shield. Avoid repeated or prolonged contact. Use only in well ventilated areas (or use approved respirator as determined by local safety industrial hygiene personnel). Keep away from open flame other sources of ignition.

(e) After proof test of a hose assembly using hydraulic fluid or oil as a test medium, flush or dip assembly in kerosene, Federal Specification VV-K-211, or degreasing solvent, MIL-PRF-680. Drain assembly and dry using by compressed air. Those assemblies tested with water as the pressure fluid will be drained and dried with dry compressed air.

(f) Install the following polyethylene protective plugs in end fittings of hose assemblies that are not to be immediately installed after fabrication: NAS 815- (\*size) (\*same dash number as fitting). Close openings in flanges (or other special fittings) using pressure sensitive tape or other adequate means to prevent entrance of foreign material.

**I. Use of Dust Plugs, Dust Caps, and Moisture Seals.** The following paragraphs provide instructions for use of plugs, caps, and seals.

**(1) Sealing with plugs, caps, and seals.** Dust plugs, dust caps, and moisture seals shall be used to provide proper closures to prevent leakage and contamination of aircraft systems when lines or units are disconnected for maintenance, repair, shipping, storage, and bulk material in free stock. See figures 4-51 through 4-56 for types of dust plugs, dust caps, and moisture seals. These plugs and seals are of plastic (polyethylene) , aluminum, steel (cadmium or zinc plates), rubber, and synthetic rubber. They will not scale or chip and require no tools for installation, hand tightening being sufficient to provide proper protection. After removal, plugs and seals shall be thoroughly cleaned and sorted for reuse.

**NOTE**

Plugs or seals shall not be used under operating pressures.

**(2) Alternate sealing methods.** Exposure to high temperature and dust conditions, such as in desert climates, cause plastic and rubber closures to shrink, deteriorate, and become difficult or impractical to use. Heavy aluminum foil may be used to protect plugs and seals from deterioration and prevent dirt and sand from entering tubing, connectors, and threaded fittings, especially on equipment stored outside. Heavy aluminum foil may also be used to protect open lines, connections, quick disconnect couplings, etc., when standard AN-SAE threaded closures are not available. Recommended aluminum foil thickness is from 0.003 to 0.005 inch, and can be locally procured or requisitioned from Federal Stock Class 9535.

**NOTE**

Prior to connection on any lines where aluminum foil has been used with standard AN-SAE threaded closures, a thorough inspection will be made to ensure that no foil has entered lines. Any conflict between this manual and the manual for a particular aircraft or other item of equipment concerning use of aluminum foil will void instruction in paragraph (2).



TM 1-1500-204-23-2

**m. Instructions for Field Assembly of Lightweight Rubber Hose Assembly. MIL-H-83796/1 thru MIL-H-83796/9.** Lightweight hose assemblies are fabricated from bulk hose conforming to MIL-F-83978, and are used for fuel and oil systems. The lightweight hose assemblies are not recommended for vacuum or hydraulic impulse application.

- (1) Inspect hose as outlined in paragraph 4-5 e (1).
- (2) Inspect fittings as outlined in paragraph 4-5 e (2).

#### NOTE

Because of contamination by foreign matter or unseen damage and wear, and because parts of fittings from different manufacturers are not interchangeable, do not salvage or reuse fittings.

- (3) The listed equipment and material are required for field assembly.

Shop vise.

Fine tooth hacksaw.

Masking tape.

10,000 psi hydrastatic test machine.

Standard wrenches.

Feeler gage.

Measuring tape.

- (4) Determine length of hose required to make assembly length "L" by use of cut-off notices on the socket. Refer to step 1, figure 4-50A.

(a) When required to fabricate a new hose assembly without any sample, drawing, or other data to determine length requirements, check the aircraft parts manual for a Military Specification (MS) identification number. An MS number contains a code which depicts the size of tube, length of assembly, and types of fittings. In absence of any of the foregoing, proceed as follows:

From the aircraft parts manual, find the figure which shows location and general position of hose.

With the fittings loosely assembled in their proper position on the aircraft, cut a piece of hose approximately three inches longer than will be required.

Hold or tape one end of hose even with groove of one nut, and maneuver the remainder of hose into a final position over other nut. Mark required length as determined by groove of second fitting and cut to size.

#### CAUTION

A hose too short will put too much tension on assembly, or a hose too loose will flap and possibly become chafed.

Fabricate hose assembly per instructions.

(5) **Cut Hose Equally to Length.** Use hose cut-off machine or fine-tooth hacksaw. To minimize wire braid flare-out, wrap hose with masking tape and saw through tape. Refer to step 2, figure 4-50A. Remove tape before doing step 3. Check to see that no wire of outside braid has become bent over end of hose.

- (6) With socket in a vise as shown step 3, figure 4-50A, insert hose into socket.

#### NOTE

Use a twisting, pushing motion to push hose into socket to a depth equal to cut-off notch. A dimensional check must be made to insure that hose is inserted to a proper depth.

(7) While socket is still in vise, mark hose position with paint, grease pencil, or tape. Refer to step 3, figure 4-50A.

(8) Lubricate Inside of hose, nipple thread, and all mating surfaces. Refer to step 4, figure 4-50A. Use SAE 30 lubricating oil.

(9) Carefully insert and engage nipple and socket threads while holding hose In position with other hand. Refer to step 5, figure 4-50A Make sure that hose does not push out of socket by observing mark make in step 3, figure 4-50A. On flange elbow fittings, drop flange over threaded end of nipple. Nipple shoulder must fit into counterbore of flange.

(10) While still holding hose, complete assembly of nipple and socket by use of a wrench. Refer to step 7, figure 4-50A. The method of determining proper tightening shall be measurement of gap between socket and nipple with a feeler gage The gap shall be 0.000 Inch minimum to 0.031 inch maximum. After completing assembly of nipple into socket, check hose position mark that was made in step 3, figure 4-50A. No push out Is permitted for size -3 through -10 In sizes -12 through -32, 1/32 inch is allowable.

(11) On hose assemblies having angle fitting on both ends, adjustment may be necessary to obtain the desired position angle between to elbows Refer to step 8, figure 4-50A In order to prevent backing elbows to position, the following procedure should supplement steps 6 and 7.

(a) Tighten both elbows to 0.040 if an Inch clearance of socket then start to position for relative angle between elbows. Refer to step 7, figure 4-50A.

(b) Finish assembly by adjusting both elbows Backing off to position should be avoided Maximum allowable gap between hex and socket is 0. 031 of an inch.

(c) The tolerance on angular alignment is f5 degrees on hose lengths up to 36 inches and i 10 degrees on hose lengths greater than 36 inches.

**NOTE**

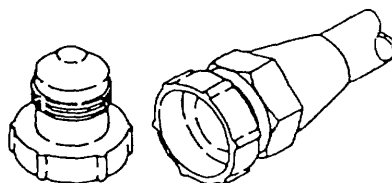
*Check for hose push-out by observing hose position mark No change should be evident.*

(12) Clean, inspect and proof test as instructed In paragraph 4-5f and table 4-17. Identify as instructed in paragraph 4-5g.

(13) After installation on aircraft, in addition to all regular Inspections, check that position and shape conform to general conditions shown in aircraft parts manual.

**4-6. Installation of Flexible Nose.** General Instructions to be followed when Installing flexible hose are outlined in paragraphs a through k and in figure 4-57.

a. Lubrication. Never, under any conditions, use oil on self-sealing hose as an aid to installation Oil or water may be used on all other types of fuel, oil, and



**Figure 4-51. Plastic Protective Dust Plug and Moisture Seal (AN-SAE Threaded)**

coolant hose when installation is made, however, oil only should be used on hydraulic and pneumatic hose.

b. Hose Installation. Install hose so that it will not be subject to twisting under any condition of operation, and there will be no tendency for the connecting fittings to loosen. When replacing hose in hydraulic, fuel oil, alcohol, water Injection, and pneumatic systems, hose installed should be a duplicate of hose removed as to length, outside diameter, Inside diameter, material, type, and contour unless otherwise directed.

c. Bends When bends are required in Installing hose in fluid systems, the radii shown in table 4-32 should be the minimum radii maintained at times for fuel, oil, and coolant systems. Table 4-32 also shows minimum bend radii for hydraulic and pneumatic systems. A radius larger than the minimum allowed is preferred.

d. Hose Restriction. When hose is installed through holes In brackets, or when supporting clips are used, there must be no reduction in diameter of hose. If this condition is present, flow will be reduced and damaged to hose may occur.

e. Support. Support hose at least every 24 inches. Closer supports are preferred Support flexible lines so that they will not cause deflection of rigid connecting lines Flexible hose between two rigid connections

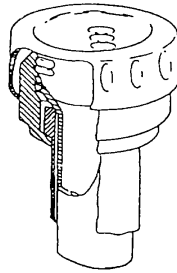


Figure 4-52. Steel Protective Dust Plug and Moisture Seal

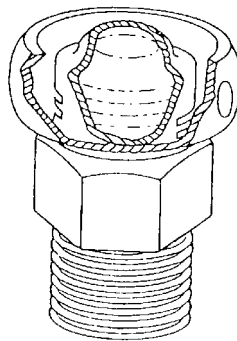


Figure 4-53. Steel Protective Dust Cap

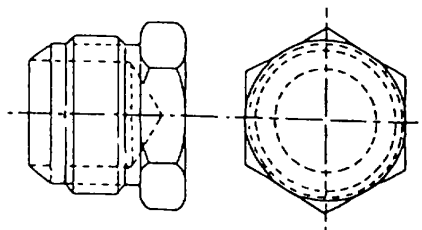


Figure 4-54. Aluminum Protective Dust Plug and Moisture Seal

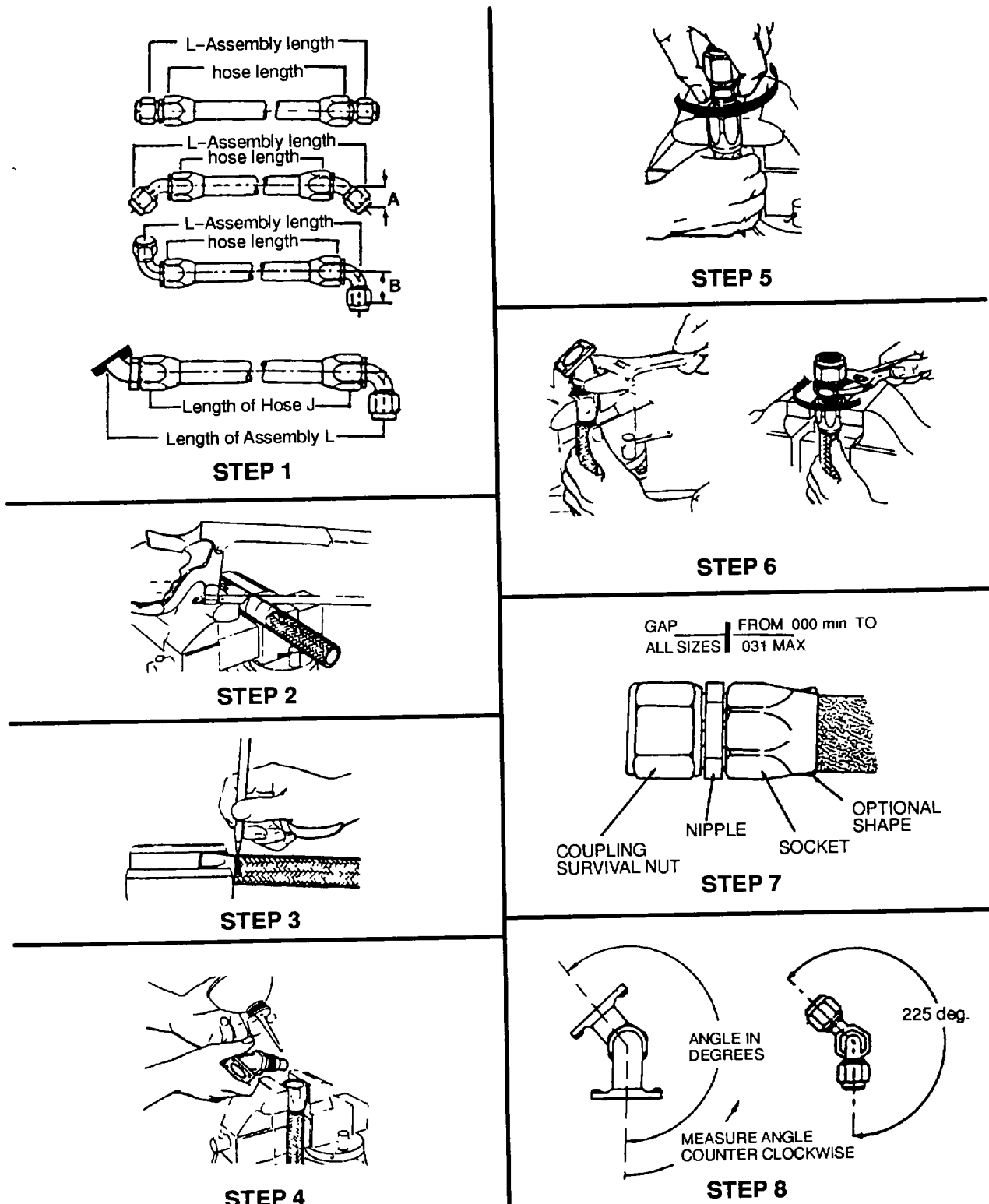


Figure 4-50A. Field Assembly of Lightweight Rubber Hose

Change 4-76.1/(4-76.2 blank)

may have excessive motion restrained where necessary, but should never be rigidly supported.

f. Chafing. Eliminate chafing by using suitable bulkhead-type grommets or cushioned clips and ensuring adequate clearance.

g. Temperature Protection. Protect hose installation from excessive temperature such as exhaust blasts, supercharger ducts, and the like, by either shrouding or relocation. Use of flame-resistant hose is preferred forward of firewall as this area is subject to high temperature under certain conditions.

h. Hose Connections to Engines. Where hose connections are made to engines or to engine-mounted accessories, install hose so 1 1/2 inches of slack or an adequate bend is provided between last point of support and attachment to engine or accessory. This prevents possibility of hose being pulled off nipple due to engine movement.

i. Hose Clamp. When a length of hose is connected to engine with a hose clamp, support hose firmly to prevent vibrational and torsional strain on hose connection. When possible, place support approximately 3 inches from engine connection.

j. Hose Markings. When possible, install hose so all markings on hose are visible.

k. MS Flared Swivel Connectors Torquing. Torque MS flared swivel connectors in accordance with tables 4-33 and 4-34.

**Table 4-32. Minimum Bend Radii of Hose for Fuel, Oil, and Coolant Systems**

Hose (Military Specification No.)	Size	Correct radii
MIL-H-8794	All	See MS33790
MIL-H-7061	Up to and including 1 1/4 inch inside diameter	R = 6 x inside diameter
MIL-H-7061	Larger than 1 1/4 inch inside diameter	R = 12 x inside diameter
MIL-H-5593	All	R = 12 x inside diameter
MIL-H-6000	All	R = 12 x inside diameter
MIL-H-7938	All	R = 12 x inside diameter

**Table 4-33. Installation Torque Values MS Flared Swivel Nut Fittings (Reference AND 10064)**

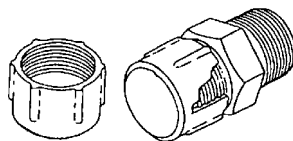
Tubing size OD inch Hose size ID Inch	Dash fitting size	Torque	
		Min.	Max.
3/16	—3	70	100
1/4	—4	70	120
5/16	—5	85	180
3/8	—6	100	250
1/2	—8	210	420
5/8	—10	300	480
3/4	—12	500	850
1	—16Z	700	1150
1-1/4	—20Z	1000	1000
1-1/2	—24Z	1000	14000

**Table 4-34. Hose End Fitting And Coupling Nut Installation Torque In Inch-Pounds**

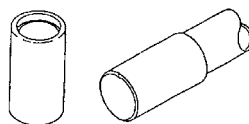
Dash size	Material <sup>1</sup>		Material II <sup>2</sup>	
	Minimum	Maximum	Minimum	Maximum
2	75	85	20	30
3	95	105	25	35
4	135	145	50	65
5	170	190	70	90
6	215	245	110	130
8	430	470	230	260
10	620	680	330	360
12	855	945	460	500
16	1140	1260	640	700
20	1520	1680	800	900
24	1900	2100	800	900
32	2660	2940	1800	2000

<sup>1</sup> Material I - Steel, corrosion resistant, and titanium fittings

<sup>2</sup> Material II - Aluminum fittings



**Figure 4-55. Plastic Protective Dust Cap**



**Figure 4-56. Plastic Protective Dust Cap (AN-SAE Friction)**

#### NOTE

- The fitting nipple should be restrained while applying torque to the nut at the fitting to prevent galling of the sealing surfaces. All adapters to hose fitting threads and contact surfaces shall be lubricated prior to application of torque.
- To find the dash size of a given fitting look on the fitting itself at the part number which is stamped on it. The last number of the part number following the dash is the fitting size, in sixteenths of an inch.
- If the part number is not stamped on the fitting, measure the outside diameter of the tubing or the inside diameter of the hose to which the fitting is attached.

**4-7. Hydraulic Packings and O-Rings.** Hydraulic seals are used throughout aircraft hydraulic systems to prevent internal and external leakage of hydraulic fluid, thereby preventing loss of system pressure. Seals used between non-moving components are called gaskets, which are generally referred to as O-rings. Seals inside a sliding or moving part are called packings.

a. O-Rings. O-rings used as gaskets are used in the sealing of boss fittings, end caps of actuators, piston accumulators, and other installations where moving parts do not come in contact with the seal. Some O-rings are used as packings where relative motion is encountered Figure 4-58 shows a typical O-ring cross section.

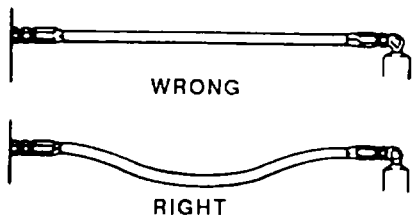
(1) *Identification.* O-rings are manufactured according to military specifications. They are identified from the technical information printed on the O-ring package (see fig. 4-59). Because the size of O-rings cannot be positively identified by visual examination without the use of special equipment, O-rings are packaged in Individual sealed envelopes labeled with all the necessary data. Colored dots, dashes, and stripes or combinations of dots and dashes on the surface of the O-ring are no longer used to identify O-rings.

(2) *Storage* Proper storage practices must be observed to protect O-rings. Most synthetic rubbers are not damaged by several years of storage under ideal conditions. Their enemies are heat, light, oil, grease, fuels, solvents, thinners, moisture, strong drafts, or ozone (form of oxygen formed from an electrical charge). Damage by exposure is magnified when rubber is under tension, compression, or stress. Conditions to be avoided include the following:

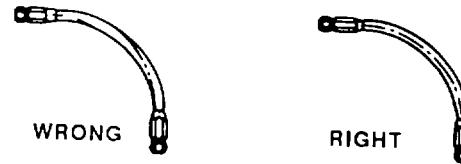
- Defects in shape resulting from improper stacking of parts and from storage in improper containers.
- Creasing caused by force applied to corners and edges any by squeezing rings between boxes and storages containers.
- Compression and flattening as a result of storage under heavy parts.
- Punctures caused by staples used in attaching identification.
- Hanging O-rings from nails or pegs where they are apt to become dirty and to develop defective shapes (O-rings should be kept in their original envelopes).
- Allowing rings to become oily or dirty by fluids leaking from parts stored above and adjacent to O-ring surfaces.
- Applying adhesive tape directly to O-ring surfaces (a torn O-ring package should be secured with a pressure-sensitive, moisture proof tape, but the tape must not contact the O-ring surface).
- Keeping over-age parts as a result of improper storage arrangements or unreadable identification O-rings should be arranged so that older seals are used first.



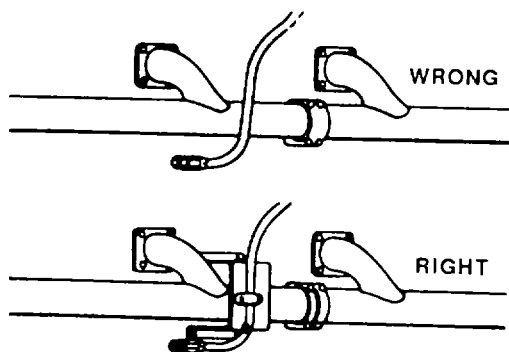
Figure 4-58. O-Ring



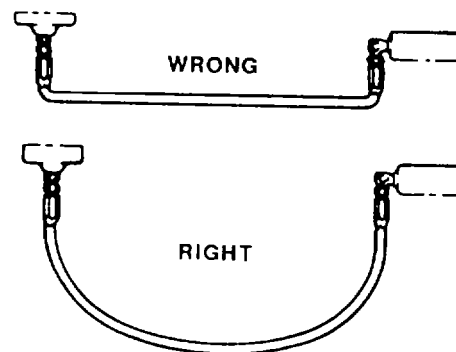
1 REMEMBER THAT THE HOSE WILL CHANGE IN LENGTH FROM +2% TO -4% WHEN PRESSURIZED PROVIDE SLACK OR BEND IN THE HOSE TO COMPENSATE FOR ANY CHANGES IN LENGTH WHICH MIGHT OCCUR



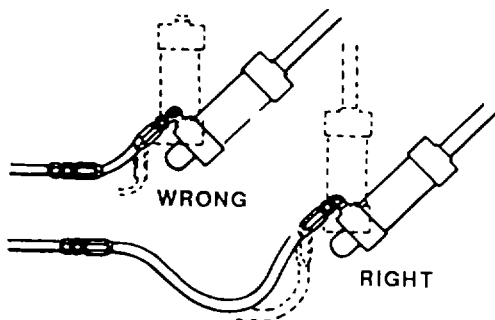
4 IF HIGH OPERATING PRESSURES ARE APPLIED TO A TWISTED HOSE, THE HOSE MAY FAIL OR THE ATTACHING NUT BECOME LOOSE



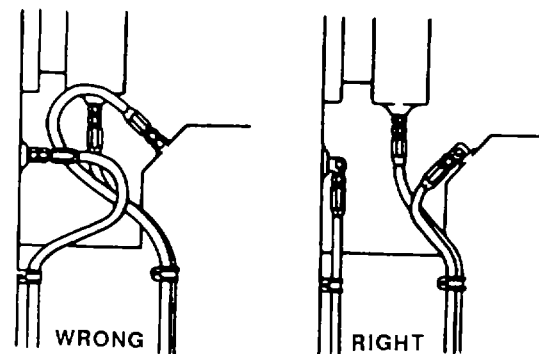
2 WHEN HOSE LINES PASS CLOSE TO A HOT EXHAUST MANIFOLD, PROTECT THE HOSE WITH FIRE-PROOF BOOT OR METAL BAFFLE



5 KEEP THE BEND RADII OF THE HOSE AS LARGE AS NECESSARY TO AVOID KINKING OF LINE AND RESTRICTION OF FLOW



3 WHEN A HOSE ASSEMBLY IS TO BE SUBJECTED TO CONSIDERABLE FLEXING OR VIBRATION, REMEMBER THAT THE METAL HOSE FITTINGS ARE NOT PART OF THE FLEXIBLE PORTION



6 USE ELBOWS AND ADAPTERS TO INSURE CLEANER INSTALLATIONS FOR EASY INSPECTION AND MAINTENANCE

Figure 4-57. Hose Line Installation Aids for All Types of Hoses



KZ5330-833-7491  
PACKING PERFORMED SYN RUBBER  
1 EACH (MS287785)  
DISC-38329  
A-5/80  
SR 810-B-90  
MFD DATE 4:80, CURE DATE 2080  
STILLMAN RUBBER CO (MFGR/ CONTR)  
MIL-G-5510A

**Figure 4-59. O-Ring Identification**

(3) Removal. When removing O-rings, care must be taken to ensure that the groove surface is not marred or scratched (see figure 4-60) The correct tool should be used In order to minimize this kind of damage. A variety of these tools may be used on any given job. They should be made from soft metal such as brass and aluminum, however, tools made from phenolic rod, plastics, and wood may also be used. Avoid using pointed or sharp-edged tools that might damage the O-ring

(a) Removing internal O-rings During removal of O-rings, the hook type removal tool is put under the O-ring and then lifted to allow the extractor tool to pull the O-ring from its place See figures 4-61 through 4-64 for removal of various configurations of O-rings

(b) Removing external O-rings. It is less difficult to remove external O-rings than internal ones. Two accepted removal methods are described In the following paragraphs

1 Spoon-type extractor. A spoon-type extractor is positioned under the seal, as shown in figure 4-65 After the O-ring Is taken from Its cavity, the spoon Is held still while the piston is rotated and withdrawn.

2 Wedge-type extractor. A Wedge-type extractor tool Is inserted under an O-ring as shown In figure 4-66, and the hook type removal tool hooks the O-ring A slight pull on the hook removes the O-ring from its cavity

(4) Installation O-rings, as a rule, require no adjustment In installation, but the precautions described In the following paragraphs must be observed or early failure will result.

(a) Cleaning. After all O-rings are removed, cleaning of the parts that will receive new O-rings is mandatory Ensure that the area used for such Installations is clean and free from all contamination

(b) Inspection. Each replacement O-ring should be removed from its sealed package and Inspected for defects such as blemishes, abrasions, cuts, or punctures. Although an O-ring may appear perfect at first glance, slight surface flaws may exist These can prevent satisfactory O-ring performance under the variable operating pressures of aircraft systems O-rings having flaws that will affect their performance should be rejected

(c) Sizing. Ensure that O-ring Is of proper size. Uniform pressure on O-ring In Installed position is necessary for satisfactory operation

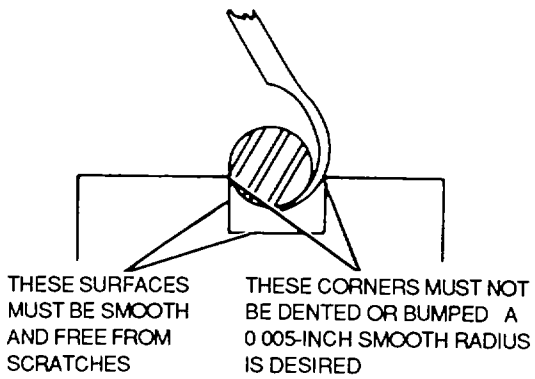
#### **WARNING**

O-ring splicing and O-ring assortment kits do not meet the specific requirements for O-ring usage on aviation equipment and are not authorized for use on Army aircraft. Use of unauthorized O-rings may compromise the integrity and safety of equipment and personnel

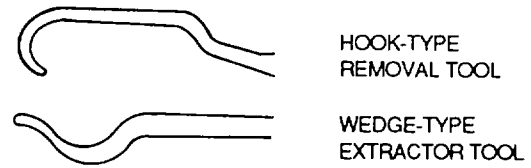
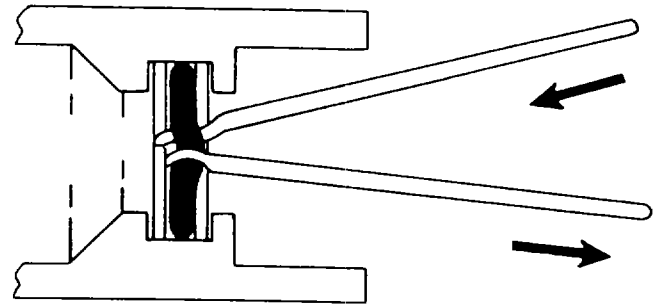
#### **CAUTION**

Never use adhesive tapes to cover danger areas on components. Gummy substances left by the adhesives are extremely detrimental to hydraulic systems.

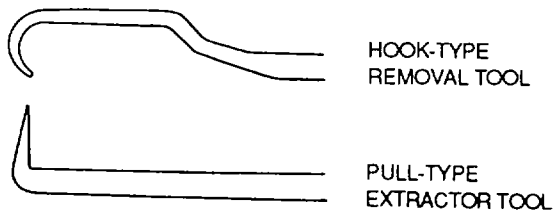
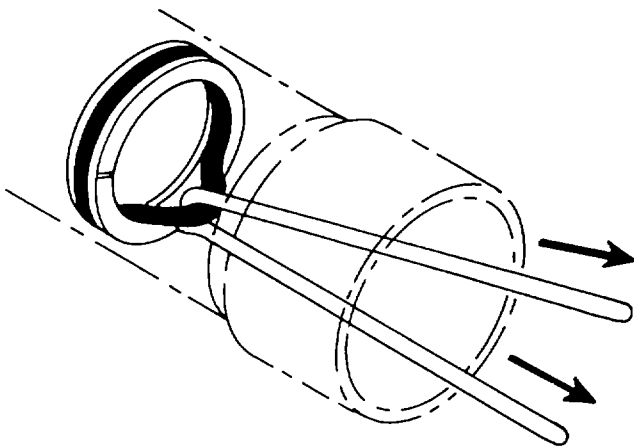
(d) Installation. Immerse rings to be installed in hydraulic systems in hydraulic fluid, MIL-H5606 or MIL-H-83282. During installation, avoid rolling and twisting the O-ring to put it Into place If possible, keep the position of the O-ring mold line constant. After the O-ring is placed In the cavity provided, gently roll the O-ring with the fingers to remove any twist that might have occurred during installation. When the O-ring installation requires spanning or Inserting through sharp threaded areas, ridges, slots, and edges, use protective measures such as the O-ring entering sleeves shown In figures 4-67 through 4-69. If the recommended O-ring entering sleeve (soft thin-wall metallic sleeve) is not available, paper sleeves and covers may be made by using seal package (gloss side out) or lint-free bond paper



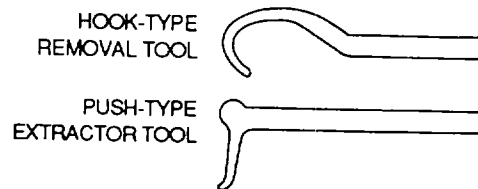
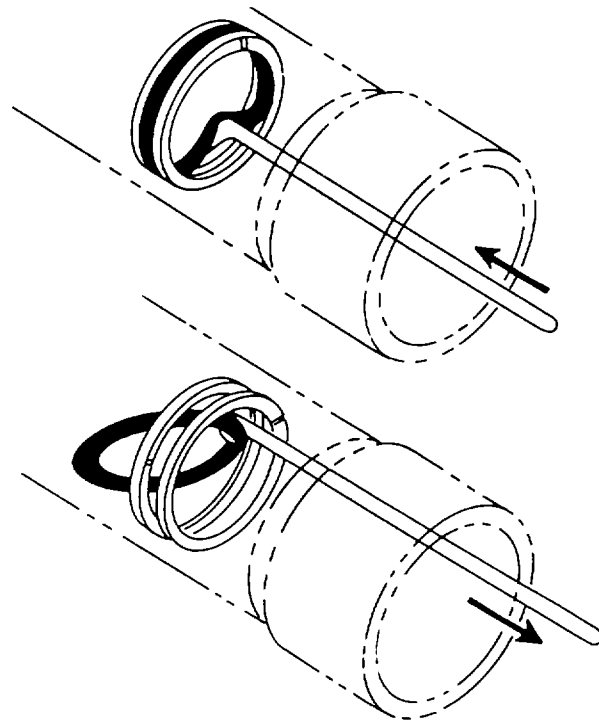
**Figure 4-60. Removing O-Ring**



**Figure 4-62. Internal O-Ring Removal (Wedge-Type Extractor)**



**Figure 4-61. Internal O-Ring Removal (Pull-Type Extractor)**



**Figure 4-63. Internal O-Ring Removal (Push-Type Extractor)**

b. Elliptical Rings. The care and handling of elliptical rings are the same as for O-rings, but elliptical rings are used in fewer applications, such as in some landing gear struts. Figure 4-70 shows a typical elliptical ring cross-section.

c. V-ring Packings. V-ring packings used in Army aircraft hydraulic installations are made of synthetic rubber. They are used in units that contain moving parts, such as actuating cylinders and selector valves.

(1) Removal and cleaning. V-ring packings are removed by much the same methods as for O-rings. After packings are removed, the area in the component must be thoroughly cleaned to prevent contamination or possible harm to the packings during or after installation.

(2) Inspection. Visually inspect each V-ring packing for cuts, nicks, or flaws before installation, and discard when any evidence of these effects is present.

(3) Installation. Figure 4-71 shows V-ring packings in various stages of installation. Prior to installation, immerse V-ring packings in hydraulic fluid, MILH-5606 or MIL-H-83282.

(a) Installation over threads. Protect V-ring packing lips when ring is installed over threads of similar projections, as shown in figure 4-71.

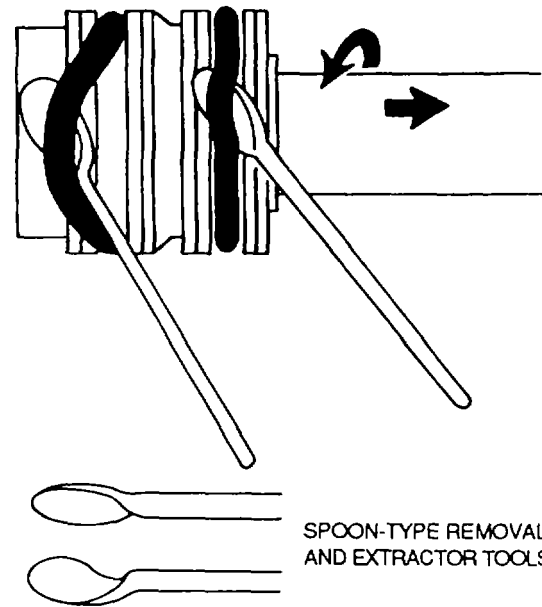


Figure 4-65. External O-Ring Removal (Spoon-Type Tools)

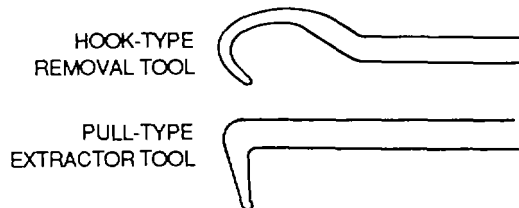
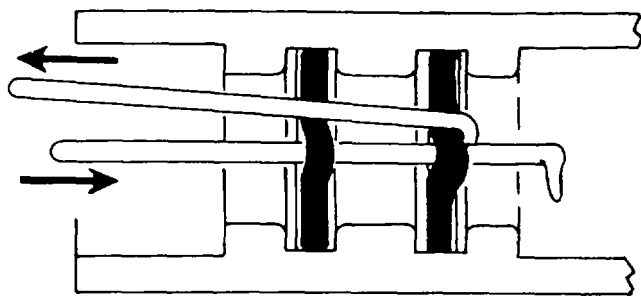


Figure 4-64. Dual Internal O-Ring Removal

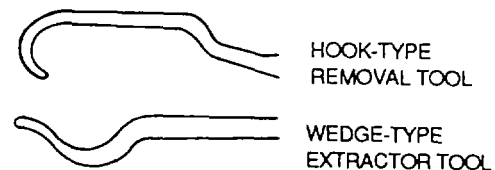
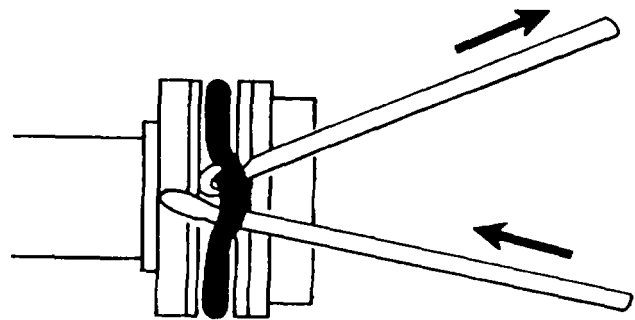


Figure 4-66. External O-Ring Removal (Wedged-Type Extractor)

(b) **Installation precautions** Install V-ring packing individually, making certain that packing is properly seated by tapping lightly with a small, clean, well-rounded blunt rod or similar instrument. Do not use screwdriver or other sharp tools. Do not install rings in sets, that is, more than one ring at a time. V-ring packings must never be squeezed excessively nor be loose in gland, but should be held firm to operate properly. Packing should contact gland walls on both inside and outside diameter.

**4-8. Backup Rings.** Backup rings are used to support O-rings and to prevent them from wearing, thus causing leakage. Teflon backup rings are generally used with both packings and gaskets; however, leather backup rings may be used with gasket type seals in systems operating up to 1,500 psi. Teflon rings are made from a fluorocarbon-resin material which is tough and friction resistant and which is more durable than leather. Backup rings made from Teflon do not deteriorate with age, they are unaffected by any other system fluid or vapor, and they tolerate temperature extremes greater than those encountered in high-pressure hydraulic systems. Precautions similar to those applicable to O-rings must be taken to avert contamination of backup rings and damage to hydraulic components.

a. **Identification** Backup rings are not color coded or otherwise marked and must be identified from package labels. The dash number, which follows the specification number on the package, shows the size, and in some cases relates directly to the dash number, of the O-ring for which the backup ring is dimensionally suited. For example, the single spiral Teflon ring MS28774-6 is used with the MS28775-006 O-ring and the double spiral Teflon ring MS28782-1 is used with the AN6227B-1 O-ring.

b. **Installation.** Care must be taken during handling and installation of backup rings. If possible, backup rings should be put on by hand and without the use of sharp tools.

(1) **Teflon backup rings** Teflon backup rings must be inspected before reuse and must be discarded if there is evidence of compression damage, scratches, cuts, nicks, and fraying conditions.

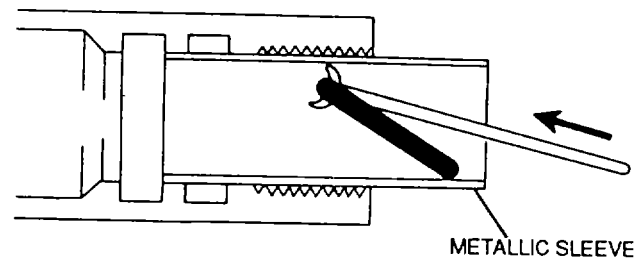
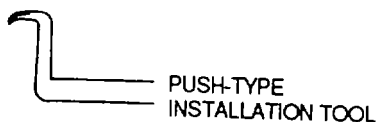
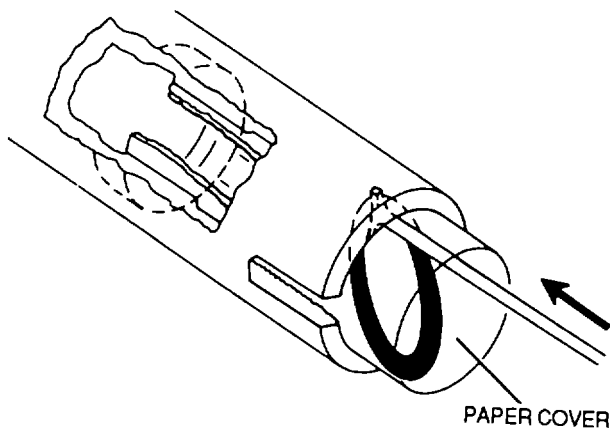
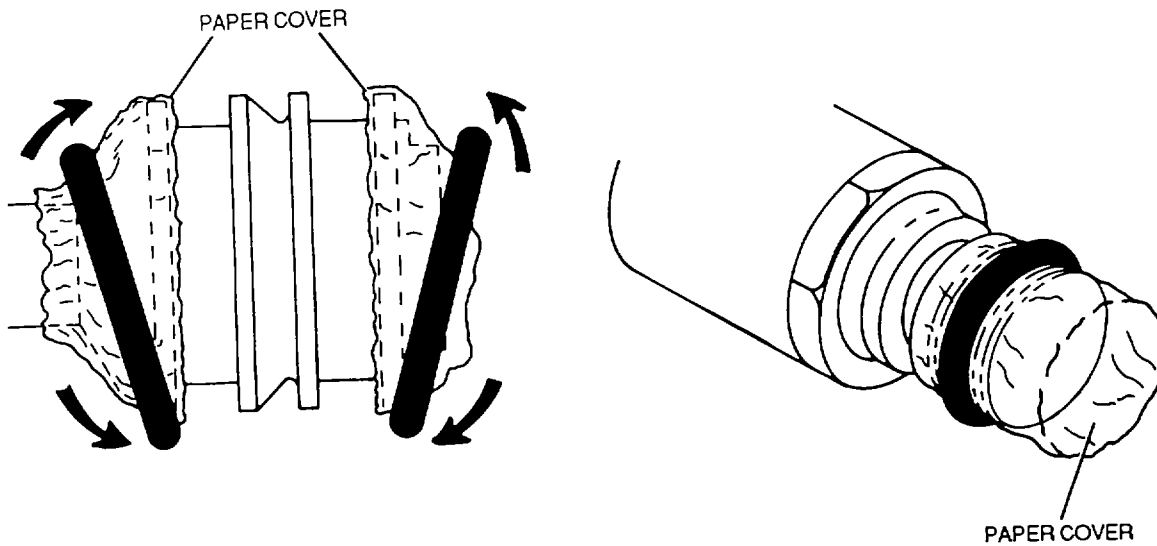


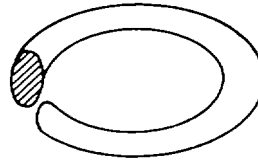
Figure 4-67. Internal O-Ring Installation(Paper Cover)

Figure 4-68. Internal O-Ring Installation (Metallic Sleeve)

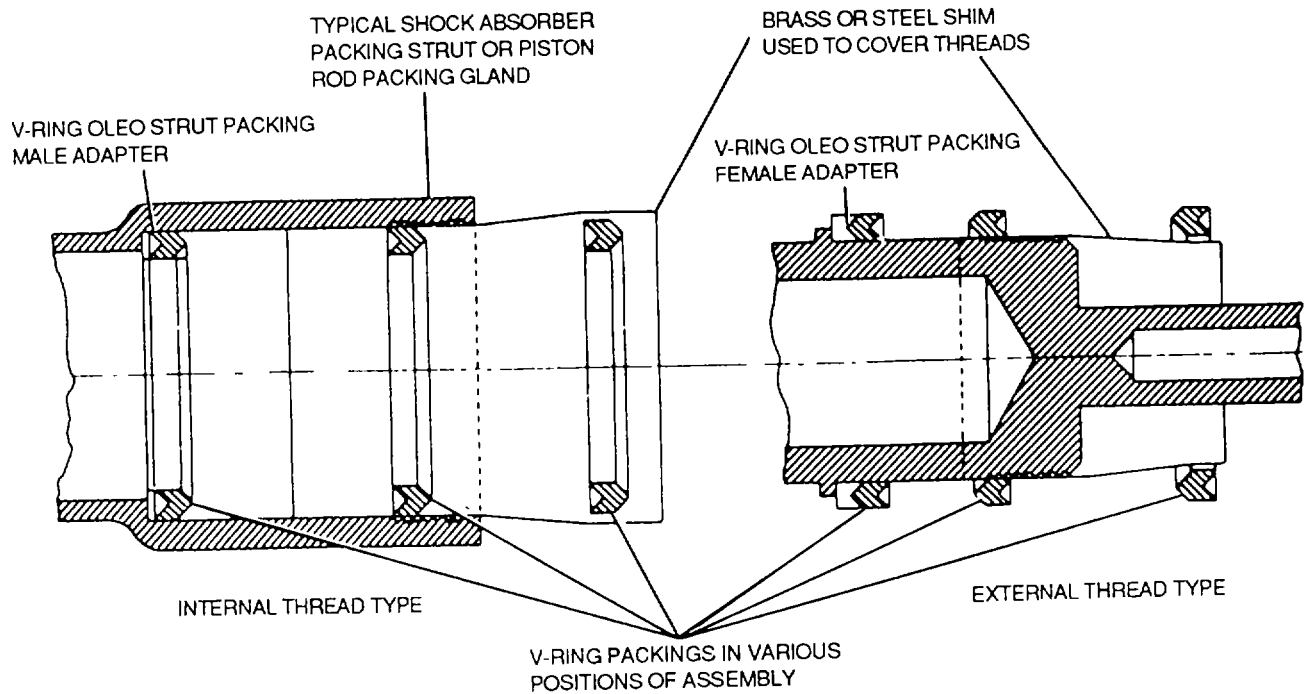


**Figure 4-69. External O-Ring Installation**

(a) Stretching. Before installing a Teflon spiral ring in an internal groove, stretch it slightly, as shown in figure 4-72. While the Teflon ring is being put in the groove, turn the component in a clockwise direction (see figure 4-73). This will tend to expand the ring diameter and will reduce the possibility of damage to the ring.



**Figure 4-70. Elliptical Ring**



**Figure 4-71. V-Ring Packings in Various Positions of Assembly**

(b) Changing spiral. Before installing a Teflon spiral ring in an external groove, you must change the right-hand spiral of the ring to a left-hand one, as shown in figure 4-74. As you put the ring into the groove, turn the component in a clockwise direction. This will tend to contract the ring diameter and will reduce the possibility of damage to the ring.

(c) Single installation. Backup rings may be installed singly if pressure acts on only one side of the seal. In figure 4-75, the backup ring is installed next to the O-ring and opposite to the pressure force.

(d) Dual installation. When dual backup rings are installed, the split scarfed ends must be staggered, as shown in figure 4-76.

(2) Leather backup rings. Leather backup rings also must be inspected before reuse for defects. Defective rings must be discarded. To install a leather backup ring, proceed as follows:

(a) Prepare a solution of distilled water and 0.05-percent sodium dichromate, Federal Specification O-S-595, by weight, in a vessel which can be heated to and maintained at 1550 ( $\pm$  50) F (68° ( $\pm$  2.8°) C.)

(b) Completely submerge leather backup rings in solution, and let soak for a period of not less than 15 minutes.

(c) Remove backup rings from soaking vessel and wipe off excess moisture. Immediately install rings as required in external seal grooves, with grain (hair) side of backup ring toward side of groove, ensuring that backup ring is well seated against one side of groove to maintain flatness when drying (see figure 4-77).

(d) Place seal with backup ring installed in drying oven with means provided for air circulation at ambient temperature of 1550 ( $\pm$  5°) F (680 ( $\pm$  2.8°) C.) for a period of not less than 25 minutes

(e) Remove from oven and allow to return to room temperature before attempting to install

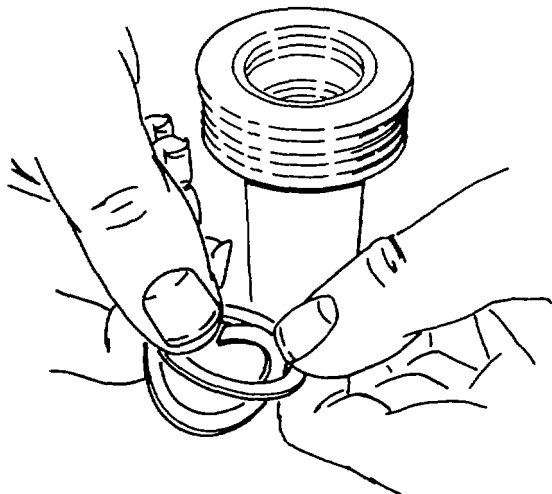


Figure 4-72. Stretching Teflon Backup Ring

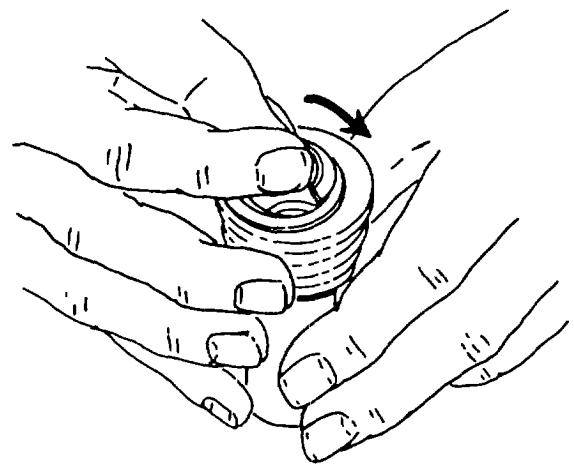
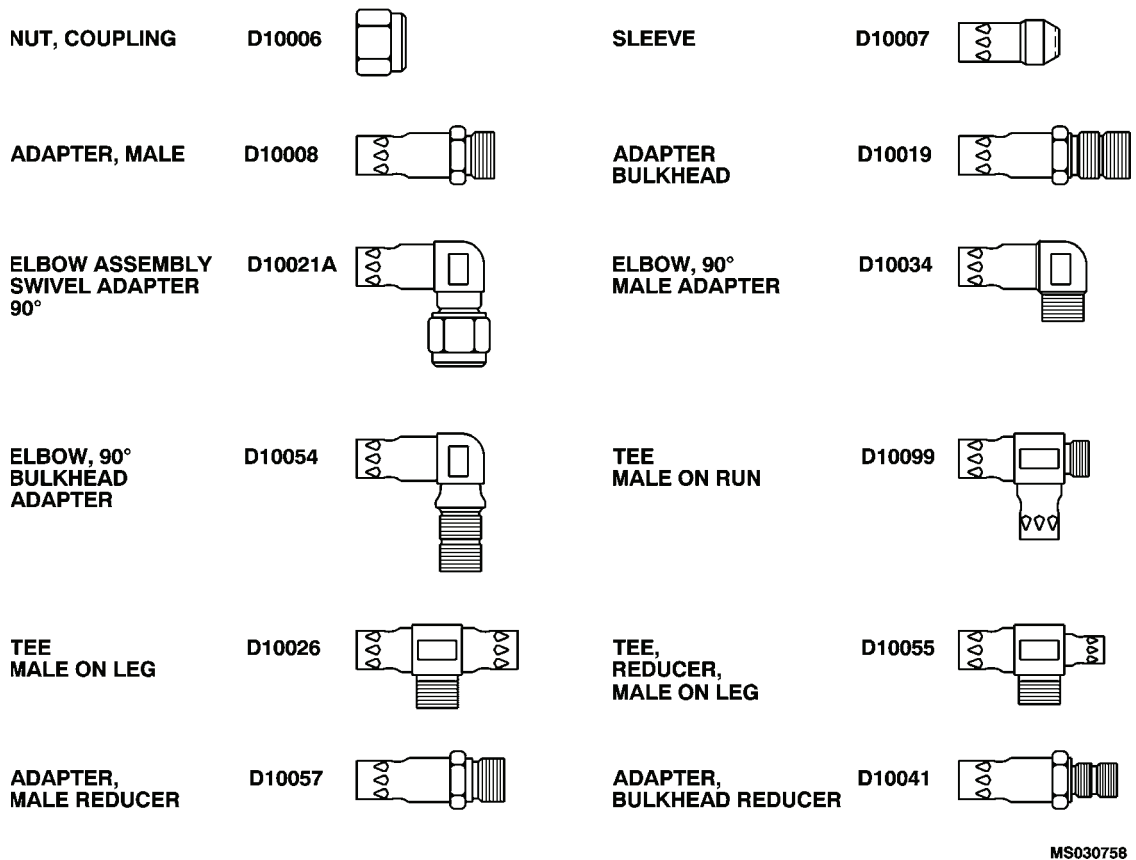
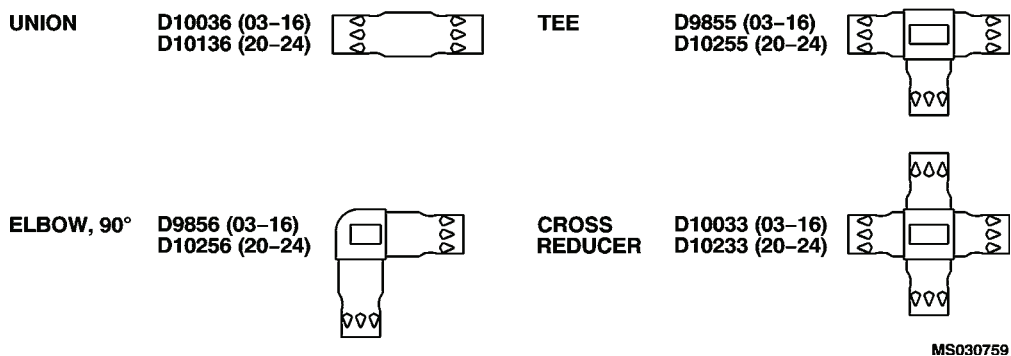


Figure 4-73. Installing Teflon Backup Ring

**4-9. SWAGED TUBING REPAIRS.** The basic element of this repair technique is the Permaswage fitting that is mechanically attached to a tube by radial swaging. These fittings make permanent and separable connections between metal tubes. It works by deforming the metal fitting onto a tube radially, 360 around the circumference, using Deutsch Lightweight Tool (DTL). The interference between the fitting and tube produce a leak resistance seal that is structurally sound. This system can be used to produce new tubes or to repair existing ones. Because the system is portable, it can be used in the field as well as in the shop. Fittings used on Army helicopters include combinations of permanent and threaded fittings for flareless connectors (See Figure 4-74) as well as permanent to permanent unions, elbows, tees, and crosses (See Figure 4-75). While numerous additional type and styles of Permaswage fittings are available, only those useable on current Army helicopter tubing are addressed



**Figure 4-74. Separable Permaswage Fittings - Flareless**



**Figure 4-75. Permanent to Permanent Permaswage Fittings**

TM 1-1500-204-23-2

**a. Description of Equipment.** The new Deutsch DTL tooling with lighter weight and more compact heads replaces the now obsolete DI2000 series tooling previously addressed in this paragraph. Deutsch field repair kit, PIN DLTFRPSKT3029 has been added to LIN T57982, NSN 5180-01-115-7008, which previously authorized only Deutsch field tool kit PIN D12102C-15-H10. Both of these kits include a hand hydraulic pump, head assemblies, and all other tools and gauges needed to install swaged fittings on tube sizes 4 (114), 6 (3/8), 8 (112), 10 (518), 12 (314), and 16 (1 in). Deutsch field repair kit, PIN DLTFRPSKT3003 has been added to LIN T57914, NSN 51 80-01 -1 15- 7007, which previously authorized only Deutsch field tool kit PIN D12102C-03- H01. These kits include a hand hydraulic pump, head assemblies and all other tools and gauges needed to install swaged fittings only on tube sizes 4 (114) and 6 (318). An additional kit PIN, DLTFRPSKT3001 is available through GSA under NSN 51 80-01 -341 -4030. The size 16 (1 in) head only required to support the CH-47 is not included in this kit.

**b. Summary of Operation.** The operation starts by preparing the tube. The tube to be connected is cut and then deburred. The installation depth is properly marked and the chosen fitting is placed on the tube. Next the swage tool is placed so it surrounds the fitting. The swaging tool is then activated by pressure from the pump. This causes the swage tool to radially compress the fitting and tube. Enough pressure is applied to swage the fitting on the tube. The swaged connection is then inspected.

**c. Preparation for Swaging.** Complete the following steps:

(1) Check sizes and material:

(a) Check material compatibility between tubing and fitting (see Table 4-35).

(b) Check for satisfactory thickness of tube walls based on tube OD, material and system/line operating pressure (see Table 4-35).

(c) Select fitting size based on tube OD.



**Table 4-35. Recommended Fitting/Tube Material & Wall Thickness Combinations (0-3000 psi)**

Fitting Material	Tube Material	Max Line Pressure (psi)	Tube OD (inch sizes)						
			1/4"	3/8"	1/2"	5/8"	3/4"	1"	
			-04	-06	-08	-10	-12	-16	
6061-T6 AL (AMS-QQ-A-225)	6061-T6 AL (AMS4083)	1,500	.035	.035	.035	—	—	—	
		1,000	.020	.028	.028 .035	.035	.035	.042 .049	
		500	—	—	—	—	—	.035	
		200	.020	.020	.020	.020	.020	.020	
21-6-9 CRES (AMS5656)	8061-T6 AL (AMS4083)	3,000	.035	.049	.064	.065	.095	—	
		1,500	.035	.035	.035	—	—	.065	
		1,000	.020	—	—	.035	.035	—	
		500	.028	.035	.035	.035	.035	.035	
	3AL-2.5V CWSR TI (AMS4944 or AMS4945)	3,000	.016	.020 .026	.026	.032	.039	.051	
		3,000	—	.028	.028 .035	.046	.058	.073	
	3AL-2.5V ANNEAL TI (AMS 4943 or GM3118A)	3,000	—	.028	.028 .035	.046	.058	.073	
		21-6-9 CRES (AMS5581)	3,000	.016	.020	.026	.032 .033	.039	.052
			2,000	—	—	—	—	—	—
			1,500	—	—	—	—	—	.020
			1,000	—	—	—	—	—	—
			500	—	—	—	—	—	—
	350	—	—	—	—	—	—		
	304 1/8HD CRES (AMS5566 or AM5854)	3,000	.02	.028	.035	.042	.058	.065	
1,500		—	—	—	—	—	—		

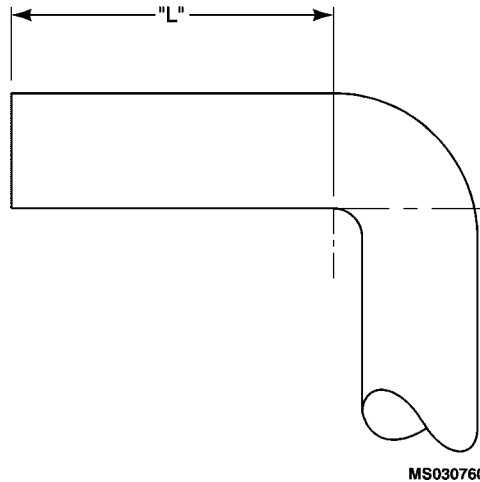
**(1) Tube Condition Prior to Installation.** The tube should be clean from any paint or other foreign materials (Swaging is permitted on Alodine finish). There should not be any flat spots, scratches or nicks on the tube. Cleaning operations on the OD of the tube can take place prior to installation. Lightly clean the tub with a rag or Scotch Bright, provided that in all cases the area of the swage remains within the tube tolerance. In all cases the O.E.M.'s installation and maintenance specifications take precedence.

**NOTE**

A minimum length of straight tube (before a bend) is required to produce a satisfactory connection. (See Table 4-36 and Figure 4-76)

**Table 4-36. Minimum Straight Tube Length Required Before Bend**

Tube OD	"L" Minimum Straight Length
1/4"	.915
3/8"	.990
1/2"	1.493
5/8"	1.533
3/4"	1.603
1"	1.748



**Figure 4-76. Minimum Straight Length**

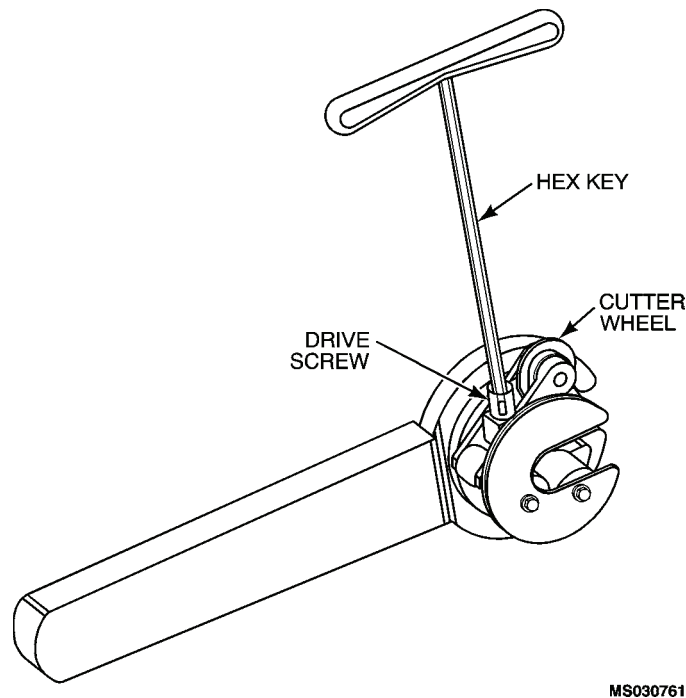
**(2) Cut Tube (if needed).**

- (a) Select tube cutter based on tube size. (See Table 4-37)
- (b) Mark cutting point on tube.
- (c) Retract cutting wheel of tube cutter by turning drive screw counterclockwise. Use screwdriver or men wrench. (See Figure 4-77)
- (d) Open cutter head by rotating tube cutting assembly inside cutter handle.

- (e) Slide tube cutter over tube.
- (f) Extend cutting wheel of tube cutter by turning drive screw clockwise until cutting wheel touches tube. Further extend cutting wheel by turning drive screw in tube cutter (approximately 1/6 turn clockwise).
- (g) Rotate tube cutter handle around tube until there is a noticeable ease of rotation.
- (h) Further extend cutting wheel by turning drive screw in tube cutter 1/20 to 1/10 turn clockwise.
- (i) Repeat steps (g) and (h) (of Section 5.2) until tube has been cut. CAUTION: Do not overturn the cutting wheel in order not to deform the tube.

**Table 4-37. Tube Cutter, Spare Cutter Wheel, & Misc Components**

Sizes	Tube Cutter PN	Spare Cutter Wheel PN	Misc. Components	PN
1/4" through 3/8"	D12530-001	D12530-109	Hex Key	DTL5103-104-01
1/2" through 3/4"	D12531-001	D12531-109	Marking Pen	DTL5301-100-01
7/8" through 1 1/2"	D12532-001	D12532-109	Swage Lube	DTLSWLUB0001



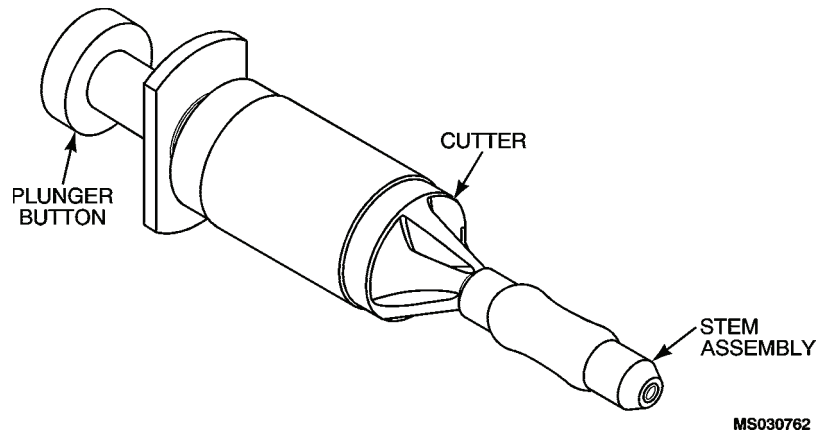
**Figure 4-77. Tube Cutter**

**(3) Deburr Tube.**

- (a) Select deburring tool stem assembly, based on tube OD. (See Table 4-38).
- (b) Insert stem assembly into deburring tool handle. Turn stem assembly clockwise until finger tight, while depressing plunger.
- (c) Release plunger, and check to see that rubber plug is expanded. Lightly lubricate rubber plug of stem assembly with swage lube.
- (d) Depress plunger of deburring tool and Insert deburring tool into end of tube. Release plunger.
- (e) Hold tube, and rotate knurled handle of deburring tool clockwise while applying slight pressure towards tube. Continue to rotate until end of tube is deburred.
- (f) WITHOUT DEPRESSING PLUNGER, withdraw deburring tool from tube until first ridge of rubber plug is exposed. Wipe ridge clean. Check end of tube for satisfactory deburring. (Leave deburring tool In tube until step (h). If tube is not satisfactorily deburred, push tool back into tube and repeat steps (e) and (f).
- (g) Wipe outside of tube clean.
- (h) Remove deburring tool from tube.
- (i) Depress plunger of deburring tool and unscrew stem from handle. Wipe stem dean, lightly lubricate and store.

**Table 4-38. Deburring Tool and Stem Assembly**

Size	Part Numbers for Standard Stem Assemblies		
	Deburring Tool	Stem Assembly	NSN
1/4	D9851-14	D9851-13-04	5110-00-05-5650
3/8	D9851-14	D9851-13-06	5110-00-133-1477
1/2	D9850-14	D9851-13-08	5110-00-003-0535
5/8	D9850-14	D9851-13-10	5110-00-003-0536
3/4	D9850-14	D9851-13-12	5110-00-003-0537
1	D9850-14	D9851-13-16	5110-00-784-7946



**Figure 4-78. Deburring Tool**

**(4) Mark Insertion Depth on Tube**

**NOTE**

If the insertion marking tool is not available, mark the insertion depth per the dimensions on Table 4-39. Be sure to use correct slot in marking guide and mark tube the entire length of the slot in marking guide.

**(a)** Mark tube as indicated by insertion marking tool. (See Figure 4-79) Use marking pen supplied in tool kit, or any other suitable marking method. Mark tube in at least two places, 180 degrees apart.

**(b)** Slide fitting onto tube.

**Table 4-39. Marking Insertion Marks without Insertion Marking Tool**

Tube OD	"A"	"B"	Part Numebr
1/4	.615"	.915"	DLT5302-013-01
3/8	.690"	.990"	
1/2	1.193"	1.493"	DLT5302-031-01
5/8	1.233"	1.533"	
3/4	1.303"	1.603"	
1	1.440"	1.745"	DLT5302-040-01

Locate points "A" and "B" distances from end of the tube. The distance "A" is the minimum insertion depth, and "B" is the maximum insertion depth. The insertion mark made on the tube must extend between "A" and "B".

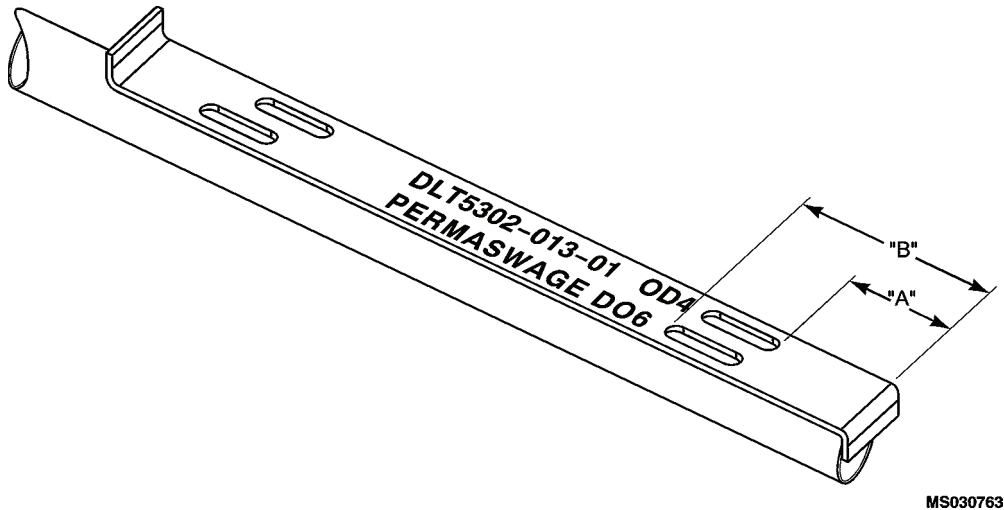


Figure 4-79. Insertion Marking Tool

d. **Operation Instructions for Swage Tooling** Complete the following steps:

**WARNING**

This tooling is subject to extremely high pressure during swaging. Improper use may result in tool failure or personal injury.

**(1) DLTPre-Swage Inspection Procedure.**

(a) Inspect the tube ends to be swaged for burrs on the outer diameter and the inner diameter. If not deburred properly, it will cut the silicone seal and scratch the I.D. of the fittings.

(b) Check the swage dies for size and to ensure they are free of foreign material between slots. The two halves must be a matched set.

(c) Check the power unit model number and head assembly part number.

(d) Check to ensure the head and the dieblock are positioned correctly with respect to the dies and the fitting.

(e) Check the insertion mark using the proper Deutsch marking tool for the tube size.

(f) Ensure proper insertion of the fitting. Part of the insertion mark must be visible with the fitting in place.

(g) Ensure that the stop endplate on the head assembly is not pushed by the fitting. The fitting must just touch the stop endplate prior to the swaging.

(h) Verify that the material, size and wall thickness of the tube are as specified.

(i) Ensure correct fitting part number and size.

(j) Verify that the pump develops 10,000  $\pm$ 250 psi hydraulic pressure. If using a pneumatic pump, the pump inlet air pressure should be 80 - 120 psi.

(k) Ensure that the two ends of the tubes being connected, or a tube end being connected to a separable joint, are aligned within a reasonable amount. No more than finger pressure must be applied to align the two tube ends.

(l) When B-nuts are involved tighten the B-nuts first, and then perform the swage in the preferred sequence.

**(2) Preparation of Tooling.**

(a) Select proper power unit and head assembly based on tube OD. (See Table 4-39.1)

(b) Push lower die/holder assembly out of head assembly.

(c) Make sure upper and lower halves of die have same serial number.

(d) Join lower die/holder assembly to top of power unit. (See Figure 4-79) (Note that this assembly will fit on power unit only one way.)

(e) Connect one end of hydraulic hose to portable hydraulic pump. Make sure pump delivers 10,000 250 psi.

(f) Connect other end of hydraulic hose to power unit.

**(g) Position Fitting On Tube.**

1 Position the fitting on the tube so that part of the tube insertion mark is covered by the fitting. Make sure part of the tube insertion mark is also outside the fitting.

**(h) Position Swage Tool.**

1 Slide head assembly over fitting and tube. Ensure beveled end of die is towards center of fitting.

2 Slide head assembly into power unit. Head assembly will fit on power unit only one way — position knurled strip on head assembly on same side as knurled strip on power unit. (See Figure 4-79)

3 Move the power unit toward the center of the fitting, until the fitting hits the end plate stop.

**(3) Swage Connection.** Apply hydraulic pressure (10,000  $\pm$ 250 psi) to the swage tool. Keep the power unit, fitting, and tube in the positions described in steps (g)1 and (h)3 of 6.2.

**(4) Remove Tooling.**

(a) Release the pressure to allow the dies to open. After the dies halves have opened, slide the head assembly out of the power unit. The two pads do not require much pressure to separate.

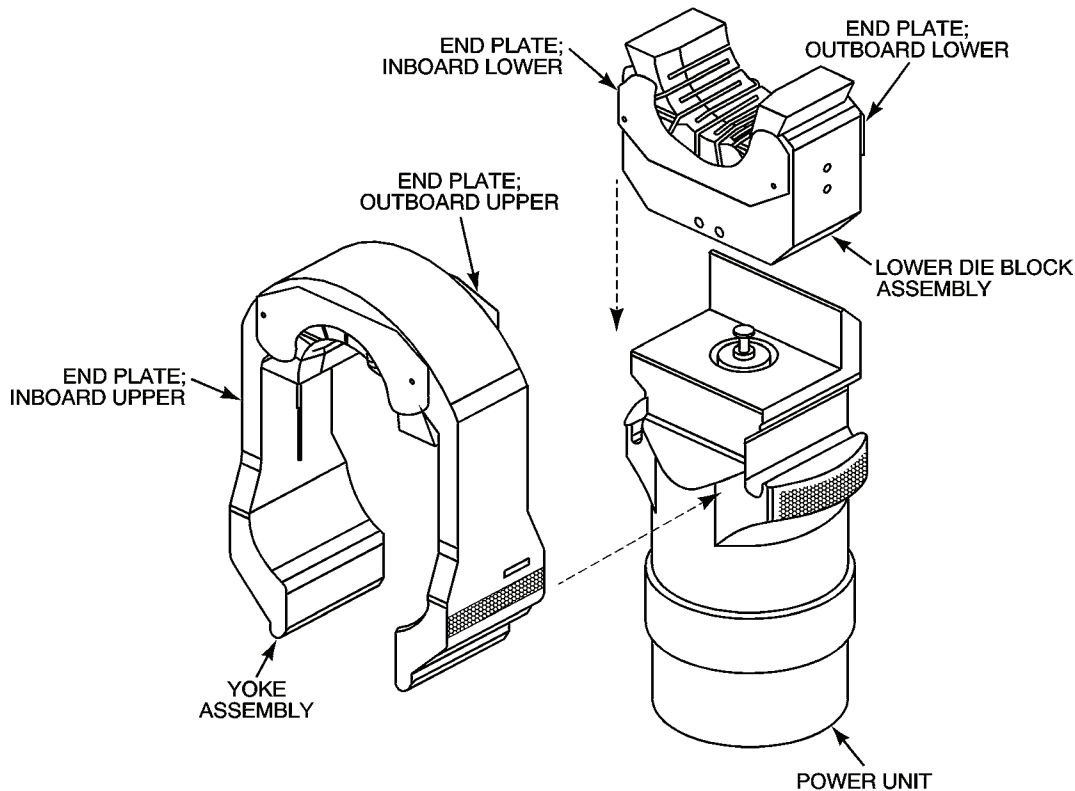
(b) Remove the head assembly from the swaged fitting/tube.

**Table 4-39.1. Power Unit, Head Assembly, Die End Plates & Screw**

Tube OD	Fitting Size	Power Unit	Head Assembly	Die
1/4"	-04	DLT06MAPW0000	DLT05PSHA3004	DLT06PSDI3004
3/8"	-06	DLT10MAPW0000	DLT10PSHA3006	DLT10PSDI3006
1/2"	-08	DLT20MAPW0000	DLT20PSHA3008	DLT20PSDI3008
5/8"	-10	DLT20MAPW0000	DLT20PSHA3010	DLT20PSDI3010
3/4"	-12	DLT30MAPW0000	DLT30PSHA3012	DLT30PSDI3012
1"	-16	DLT40MAPW0000	DLT40PSHA3016	DLT40PSDI3016

Fitting Size	End Plates				Screw, Socket, Head, Flat
	Inboard Upper	Inboard Lower	Outboard Upper	Outboard Lower	
-04	DLT05PSEU3004	DLT05PSEL3004	DLT05PSFU3004	DLT05PSFL3004	MS24671-1
-06	DLT10PSEU3006	DLT10PSEL3006	DLT10PSFU3006	DLT10PSFL3006	MS24671-1
-08	DLT20PSEU3008	DLT20PSEL3008	DLT20PSFU3008	DLT20PSFL3008	MS24671-1
-10	DLT20PSEU3010	DLT20PSEL3010	DLT20PSFU3010	DLT20PSFL3010	MS24671-1
-12	DLT30PSEU3012	DLT30PSEL3012	DLT30PSFU3012	DLT30PSFL3012	MS24671-1
-16	DLT40PSEU3016	DLT40PSEL3016	DLT40PSFU3016	DLT40PSFL3016	MS24671-1



MS030764

**Figure 4-79. Head Assembly, Lower Die Block assembly and Power Unit**



**e. Inspection of Swaged Connections.** Complete the following steps:

**NOTE**

Inspect swaged fittings only with inspection gages supplied by Deutsch Metal Components — use no other method. To verify dimensions of inspection gauges, see Table 4-39.3.

- (1) Select inspection gage, based on size of fitting. (See Table 4-39.3 & Figure 4-80).

Swage fittings must be inspected after swaging. This action verifies the fitting has been compressed accurately.

- (2) Place inspection gage over swaged end of fitting. Ensure internal shoulder of gauge contacts end of fitting. (See Figure 4-81)

Outside diameter of fitting must be smaller than ID of gauge. Part of the die marks on fitting must be visible outside of gauge.

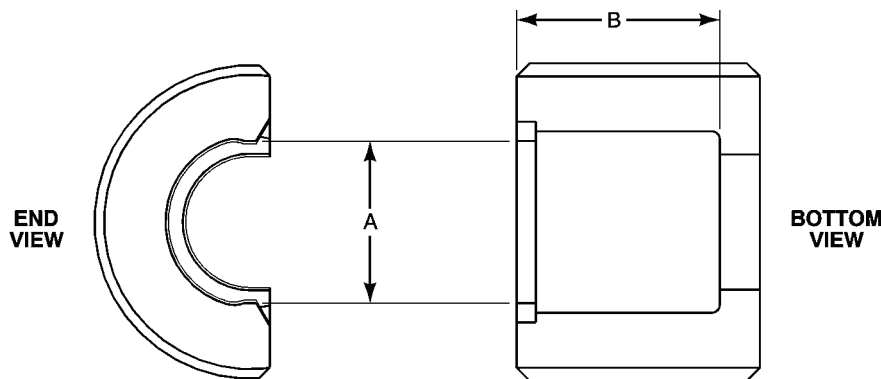
**NOTE**

If inspection gauge does not fit properly over the swaged fitting, reswage the fitting. If dimensions of swaged fitting are still not satisfactory, contact Deutsch Metal Components representative for assistance.

- (3) Rotate gauge 90°, and repeat step (2) above.

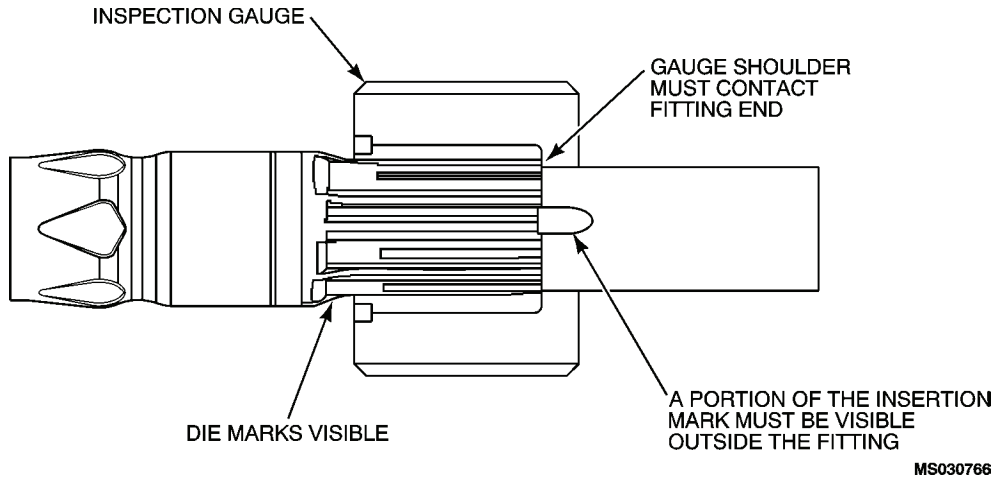
**Table 4-39.2. Inspection Gauge (0-3000 psi max)**

Fitting Size	Gauge		Inside Diameter "A" ±.002 (inches)	Inside Length "B" ±.003 (inches)
	Permaswage No.	NSN		
-04	12-9892-04	5220-00-005-5636	.315	.460
-06	12-9892-06	5210-00-005-5638	.3447	.584
-08	12-9892-08	5210-00-004-4912	.606	1.020
-10	12-9892-10	5210-01-251-3823	.735	1.020
-12	12-9892-12	5210-00-004-4914	.863	1.020
-16	12-9892-16	5220-00-882-7951	1.144	1.160



MS030765

**Figure 4-80. Inspection Gauge**



**Figure 4-81. Using Inspection Gauge**

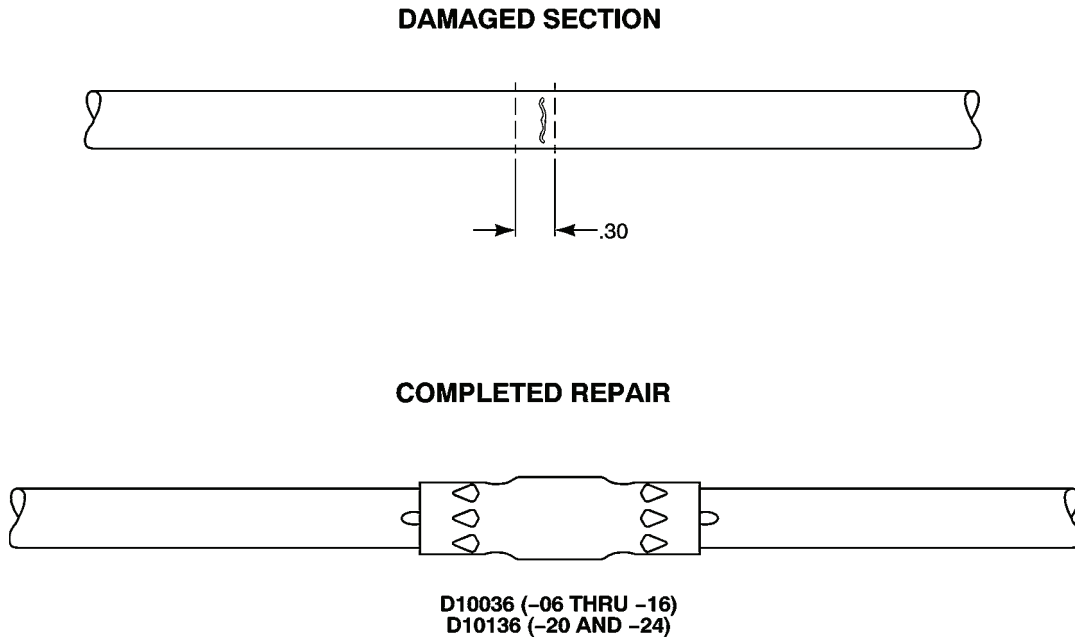
**f. Tube Repair Techniques.** Four basic types of tubing system failures lend themselves to permanent repair using Permaswage techniques. The failure types and recommended repair procedures (one per page) are as follows:

**(1) Type 1 – Small Hole or Short Crack in Tube.**

**(a)** Make one or two cuts as necessary to allow removal of damaged tube section. (If two cuts are required, and the distance between cuts exceeds 0.30", use repair TYPE 2.)

Cut the tube only after checking to assure enough space is available to operate the swage tool.

**(b)** Replace removed section of tube with a compatible Permaswage® union fitting.

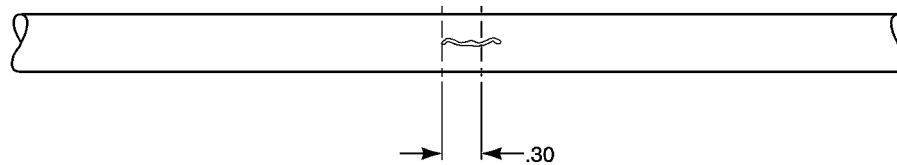


**Figure 4-82. Type 1 Repair**

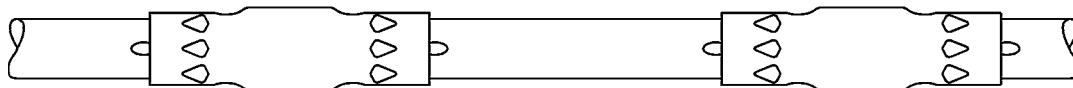
**(2) Type 2 – Lengthwise Crack in Tube (Crack Longer Than 0.30 Inches).**

- (a) Make two cuts to allow removal of damaged section of tube. Cut the tube only after checking to assure enough space is available to operate the swage tool.
- (b) Use a tube splice and two compatible Permaswage® union fittings to recreate the section of tubing which was removed. Assemble these parts into the line being repaired before you swage the fittings.
- (c) Swage each end of the fittings.

**DAMAGED SECTION**



**COMPLETED REPAIR**

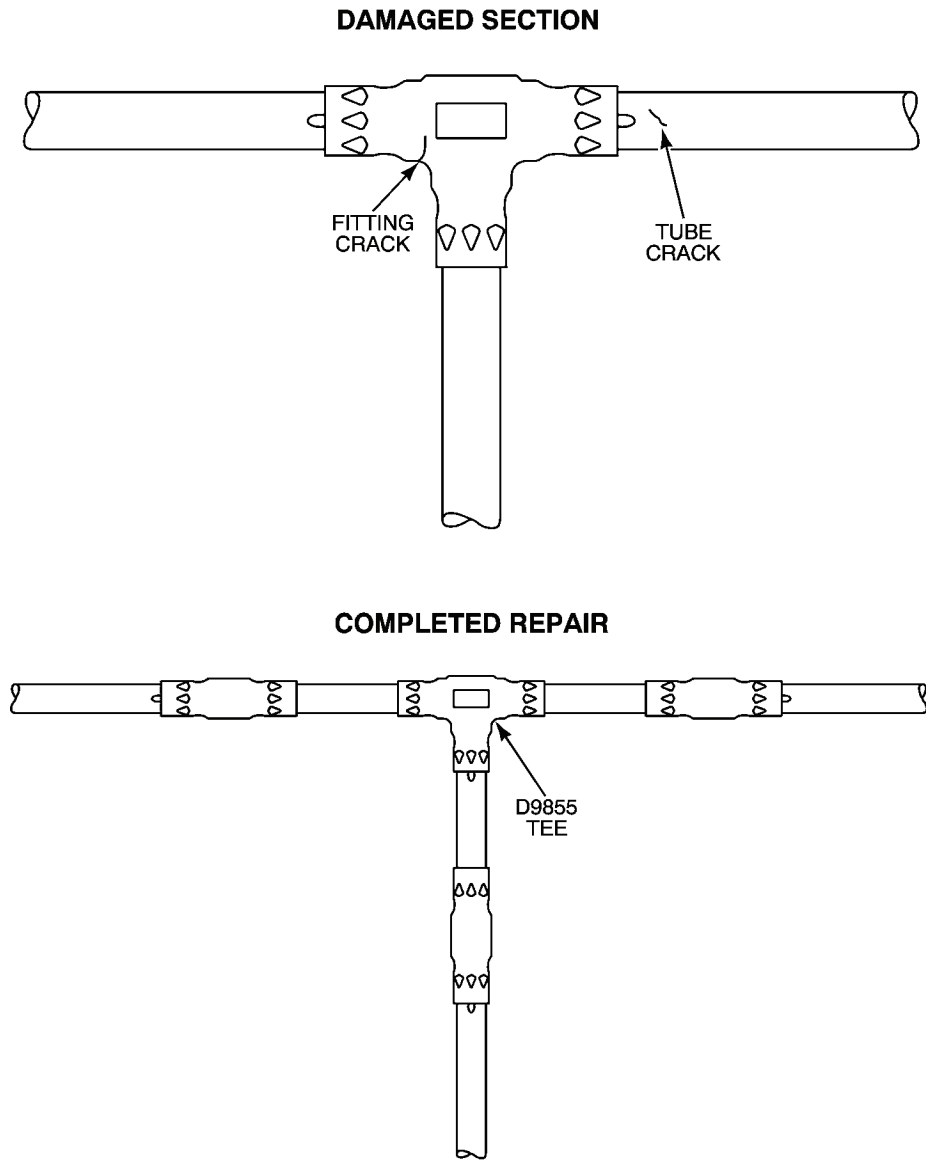


MS030781

**Figure 4-87. Type 2 Repair, Crack is longer than 0.30"**

**(3) Type 3 – Leaking Tube or Fitting Associated with Elbow, Tee or Cross.**

- (a) Cut out defective elbow, tee, or cross. Cut the tube only after checking to assure enough space is available to operate the swage tool.
- (b) Swage tube splices to a compatible Permaswage® elbow, tee, or cross fitting. Do this to recreate section of tubing system which was removed.
- (c) Swage each leg (tube) of this assembly to the tubing being repaired. Use Permaswage® union fittings.



MS030782

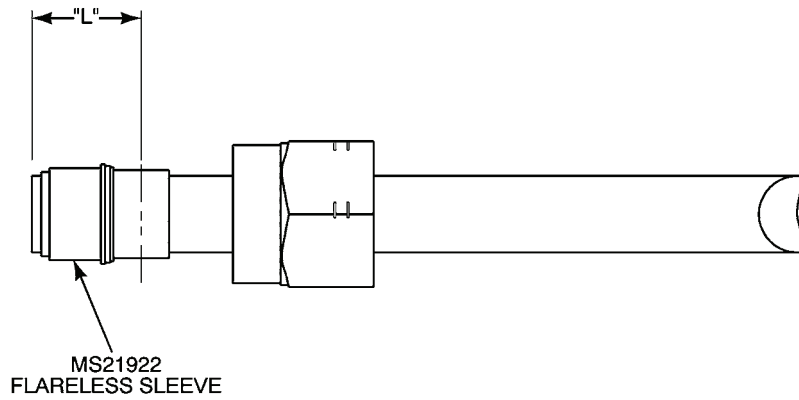
Figure 4-88. Type 3 Repair

**(4) Type 4 – Damaged Tube or End Fitting (flareless female).**

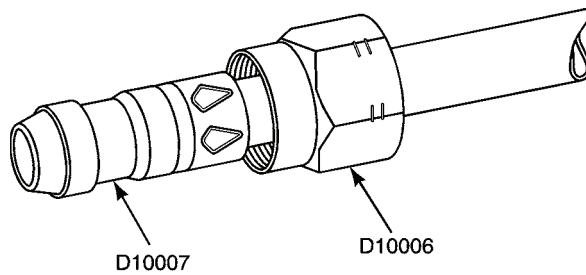
(a) Cut off the flared end of the tube as shown in Figure 4-89. Refer to Table 4-39.3 to determine the cutoff length ("L"). Use of these cutoff lengths permits repair of the line without splicing new tubing into the line.

(b) Replace the removed fitting with a compatible Permaswage® D10007 flared deem and D10006 coupling nut. (Insert the end of the tube being repaired into the flared sleeve as far as possible before swaging. This will duplicate the original overall length of the assembly.)

**DAMAGED SECTION**



**COMPLETED REPAIR**



MS030767

**Figure 4-89. Type 4 Repair**

**Table 4-39.3. Inspection Gauge (0-3000 psi max)**

Tube Size (inches)	Fitting Size	"L" (±.010)
1/4"	-04	.541
3/8"	-06	.508
1/2"	-08	.588
5/8"	-10	.600
3/4"	-12	.628
1"	-16	2.110

**g. Frequently Asked Questions.**

1. Is it OK to swage a fitting more than once?

YES. It is OK to swage a fitting more than once — just be sure that you're using the correct die set. And be sure that your hydraulic pump is delivering the right amount of pressure to the swage tool.

2. If a joint is weeping or leaking, should the fitting be swaged again?

If a Permaswage® joint begins to weep or leak, the leakage will often be stopped by swaging the fitting again.

3. How many fittings can be swaged into a line?

As many as will fit. Allow a minimum distance of one tube diameter between fittings.

4. Is it OK to glue fittings onto tube?

NO. Do not glue at any time.

Refer any questions to your Deutsch Metal Components representative (web address: [www.deutschco.com](http://www.deutschco.com))

**h. Basic Maintenance.** This paragraph covers regular inspections, cleaning, and stowage of the equipment. Also covered is how to replace the cutter wheel of the tube cutter.

**NOTE**

Parts of this tooling are subjected to extremely high forces – the following procedures must be performed as often as specified to ensure safe and successful operation.

**Inspections and Cleaning of Tooling**

<b>Procedure Performed</b>	<b>How Often</b>
Check All Components If any deep scratches, gouges, dimples or abnormalities appear, discontinue use and contact Deusch Metal Components	Before each use
Check Die Sets Upper and lower halves must be a serialized set. They must be clean. Apply Deutsch Swage Lube to the heads and dieblocks prior to installing the dies.	Before each use
Check Connection Paths Components must be clean in all areas where they contact each other	Each time components are connected.
Check Tube Cutter Cutting wheels must be sharp. Rollers must be parallel and not wobbly.	Before each use.
Lubricate Tube Cutter Lubricate ratchet, rollers and cutter wheel with light oil.	As required to ensure ease of operation.

**(1) Storing Equipment After Use.** Replace protective caps over all connectors before storing equipment. Storing the equipment without replacing the protective caps can cause the equipment to fail.

**(2) How to Replace Cutter Wheel of Tube Cutter (Figure 4-77).** The cutter wheel in the tube cutter should be replaced whenever it becomes too dull to cut efficiently. It should also be replaced if it becomes damaged in any way.

**4-10. QUICK-DISCONNECT COUPLINGS.** Quick-disconnect couplings of the self-sealing type are used at various points in all hydraulic systems. These couplings are installed at locations where frequent uncoupling of lines is required for inspection and maintenance. Each coupling assembly consists of two halves held together by a union nut. Each half contains a valve which is held open when the coupling is connected, allowing fluid to flow in either direction through the coupling. When the coupling is disconnected, a spring in each half closes the valves, preventing loss of fluid and entrance of air. The union nut has a quick-lead thread which permits the coupling to be connected or disconnected by turning the nut. Various types of union nuts are used in hydraulic systems. For one type, a quarter-turn on the union nut locks or unlocks the coupling. For another type, a full turn is required. Some couplings require wrench tightening; others are connected and disconnected by hand. Some installations require that the coupling be secured with safety wire; others do not require any form of safetying. Because of these differences, all quick disconnects must be installed in accordance with the instructions in the applicable maintenance manual. However, following are general guidelines for installation and inspection.

**a. Installation.** When installing a coupling, the coupling can be fully connected by hand. The external shape of the union nut sleeve is such that it can be tightened by a wrench. The union nut must be tightened until it can no longer rotate.

**b. Inspection.** The quick-disconnect coupling will be inspected as follows:

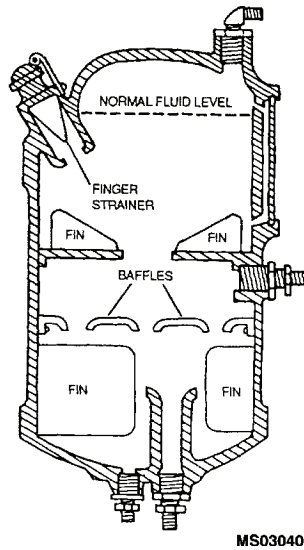
- (1)** Inspect union nut for tightness and security.
- (2)** Inspect coupling for leaks when pressure is applied.
- (3)** Actuate affected component to ensure free flow through the coupling.

**4-11. HYDRAULIC RESERVOIRS.** The system reservoir holds enough fluid for use in operation of the system and to replace fluid lost through minor leakage or evaporation. Reservoirs may also be installed to provide a space for increase in fluid volume over the original amount, such as that which might occur through thermal expansion or foaming. They also provide a place of escape for air trapped in the system.

**a. Types of Reservoirs Used in Hydraulic Systems.** Two types of reservoirs are used in aircraft hydraulic systems: the in-line and the integral type.

**(1) In-line.** The in-line reservoir, seen in figure 4-91, has its own housing, is complete within itself, and is connected with other components in the system by tubing or hose. The in-line type is most common in Army aircraft, and is covered in this manual.

**(2) Integral.** The integral reservoir consists merely of a space set aside within a major component for the purpose of holding a supply of operational fluid. An example of this kind of reservoir is an automotive brake master cylinder.



**Figure 4-91. Reservoir with Baffles, Fins and Finger Strainer**

**b. Theory of Operation.** A space is provided in the reservoir above the normal level of the fluid for fluid expansion and for escape of trapped air. Most reservoirs are designed so they cannot be serviced completely to the top. This is done by locating the filler neck somewhat below the top of the reservoir. On most reservoirs, a dipstick or glass sight gauge is provided so that fluid level can be easily and accurately checked. All reservoirs are either vented or closed to the atmosphere and pressurized.

**(1) Vented reservoirs.** In vented reservoirs, atmospheric pressure and gravity are the forces which cause fluid to flow out of the reservoir and into the pump. In order to supply a pump with fluid, a vented reservoir must be positioned at a higher location than the pump. If the reservoir and the pump were at the same level, gravity would have no effect on fluid flow. If the reservoir was at a level below the pump, fluid would tend to run out of the pump and into the reservoir. Most hydraulic system reservoirs of current Army aircraft are vented.

**(2) Pressurized reservoirs.** In the hydraulic systems of some aircraft, it is necessary to mount the reservoir at a level below the pump. In this case, the weight of the fluid obviously deters, rather than aids, the flow of fluid into the pump. A reservoir so located has to have the fluid it contains under greater than atmospheric pressure to force the fluid upward into the pump. Another reason for pressurizing reservoirs is to enable aircraft to fly at very high altitudes. Since atmospheric pressure decreases as altitude increases and at very high altitudes become too low to force enough fluid into a pump, the reservoir has to be pressurized. Two general methods of pressurizing reservoirs are employed. One method employs fluid, the other air.

**(a) Fluid-pressurized reservoir.** This method makes use of fluid pressure bled from the pressure lines of the system in which the reservoir is incorporated. The reservoir is designed in such a way as to develop a relatively low pressure on the supply fluid contained in the reservoir by use of a stream of fluid fed into the reservoir at a much higher pressure. Such a reservoir is commonly called an airless reservoir.

*Construction.* Figure 4-92 shows the construction and operation of a typical reservoir pressurized in this manner. The major parts of the assembly are a cylindrical housing that has three fluid ports and a polished bore, a housing tube which terminates in a head, and a piston and piston tube assembly. The piston and piston tube assembly are free to slide back and forth relative to the housing. The housing tube and head are stationary.

*Operation.* In operation, as shown in figure 4-93, fluid pressure admitted to the housing tube at system operating pressure—of example, at 3,000 psi—enters the space formed between the piston and the housing tube head. This pressure tends to force the piston and housing tube head in opposite directions. However, since the housing tube head cannot move and the piston can, the piston moves toward the right, pushing against the supply fluid on its right



and thus developing pressure in the fluid. The surface of the housing tube is exposed to 3,000 psi pressure within a space that is one-sixtieth as large in area as the piston surface that contacts the supply fluid. This means that a pressure of 50 psi (3,000 psi ÷ 60) is built up in the supply fluid.

**(b) Air-pressurized reservoir.** Pressurizing with air is done by forcing air into the reservoir above the level of the fluid. The amount of pressure kept in an air-pressurized reservoir is usually around 15 psi. No attempt is made to keep the air and fluid separated. In most cases, the initial source of air pressure in the compressor section of the aircraft engine. Since pressure within the engine compressor is normally about 100 psi, it has to be reduced before being delivered to the reservoir. This is accomplished by passing the air through an air pressure regulator.

**c. Baffles and Fins.** Baffles and/or fins are used in most reservoirs to prevent the fluid within the reservoir from swirling and surging. These conditions could cause fluid to foam and air to enter the pump along with the fluid (see figure 4-93).

**d. Finger Strainers.** Many reservoirs have strainers in the filler neck to keep foreign matter from entering when the filler cap is off. These strainers are made of fine gauze and are called finger strainers because of their shape. Finger strainers should never be removed or punctured as a means of speeding up the pouring of fluid into the reservoir (see figure 4-93).

**e. Filter Elements.** Filter elements are incorporated in some reservoirs either to filter air before it enters the reservoir or to filter fluid before it leaves the reservoir. Figure 4-94 shows these filters installed. When an air vent filter element is used, it is located in the upper part of the reservoir above the fluid level. When a fluid filter element is used, it is located at or near the bottom of the reservoir. Fluid returning to the reservoir surrounds the filter element and flows through the wall of the element. This leaves any fluid contaminant on the outside of the element. The fluid filter elements commonly used in aircraft reservoirs are made of treated cellulose formed into accordion-like pleats. This construction exposes the fluid to the maximum amount of filter surface within a given space.

**f. Filter Element Bypass Valve.** Reservoirs having filter elements have a bypass valve to ensure that the pump will not be without fluid even if the filter element becomes clogged. This valve is normally held closed by a spring that would be opened by the stronger partial vacuum that would develop if the element became badly clogged.

**g. Standpipes.** Some aircraft have emergency hydraulic systems that take over if the main system fails. In many such cases, the pumps of both systems obtain fluid from a single reservoir. Under such circumstances, fluid for the emergency pump is drawn from the bottom of the reservoir and the main system draws its fluid through a standpipe located at a higher elevation. With this arrangement, operation of the emergency system is ensured should the main system fail.

**h. Air Cylinders.** Air cylinders are the pneumatic reservoirs in an aircraft pneumatic system, which serves as an emergency source of pressure for the hydraulic system. These cylinders are made of steel and may have a cylindrical or a spherical shape (see figure 4-95). Cooling of the high-pressure air in the storage cylinders will cause some condensation to collect in them. To ensure positive operation of systems, storage cylinders must be purged of moisture periodically. This is done by slightly cracking the moisture drain fitting located on the cylinder manifold.

**i. Maintenance of Reservoirs.** A typical reservoir consists essentially of a reservoir shell assembly which houses a filter element, relief valve, and required gaskets, seals, and O-ring packings.

**WARNING**

Degreasing solvent, MIL-PRF-680, is combustible and toxic to eyes, skin and respiratory tract. Wear protective gloves and goggles/face shield. Avoid repeated or prolonged contact. Use only in well ventilated areas (or use approved respirator as determined by local safety industrial hygiene personnel). Keep away from open flame other sources of ignition.

- (1) Wash all parts and flush inside of tank with degreasing solvent, MIL-PRF-680. Dry with compressed air.

TM 1-1500-204-23-2

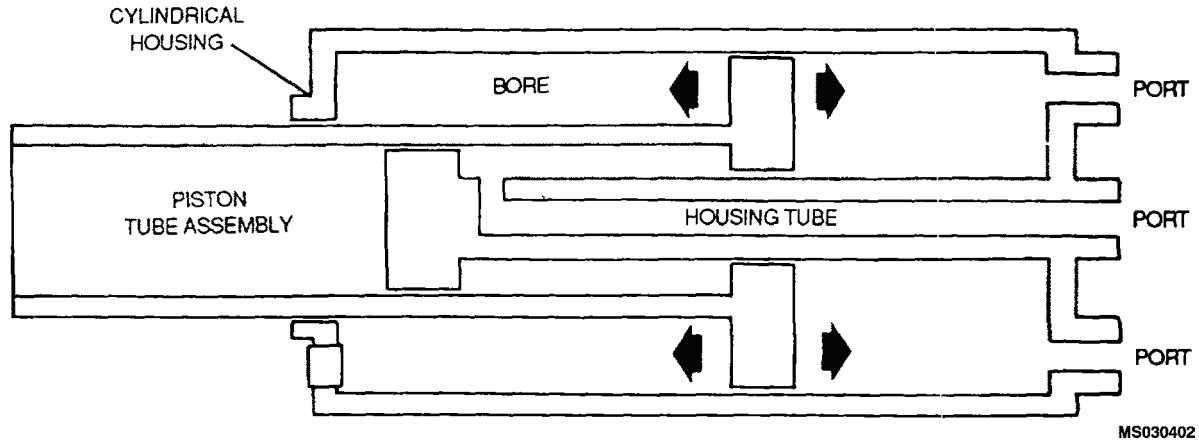


Figure 4-92. Fluid-Pressurized Reservoir (Unpressurized)

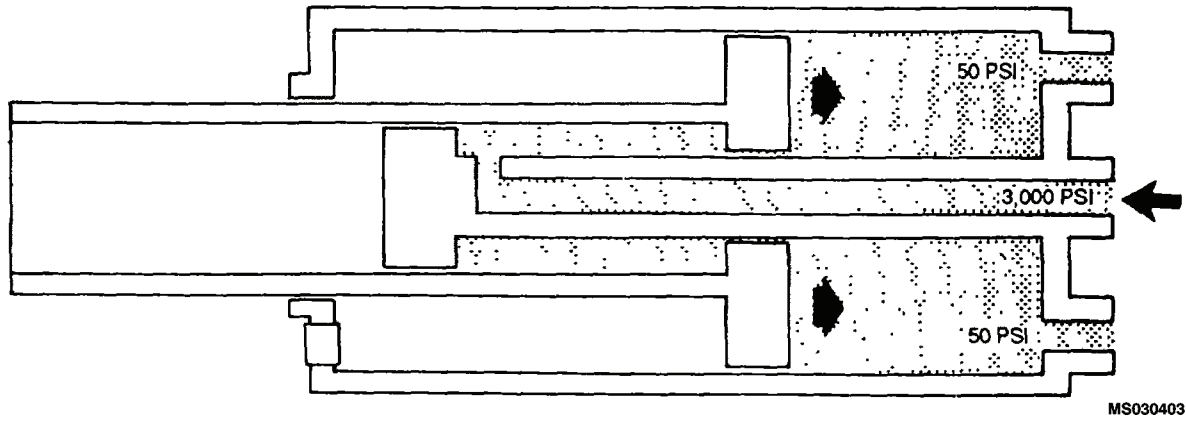
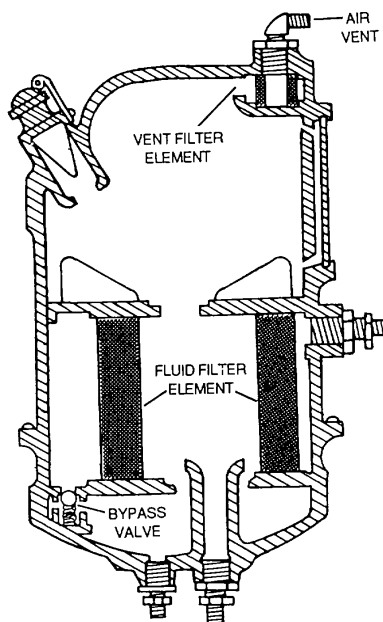


Figure 4-93. Fluid-Pressurized Reservoir (Pressurized)



**Figure 4-94. Reservoir with Filter Elements**

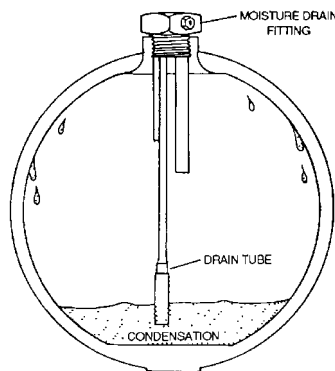
**CAUTION**

The use of any alcohol in cleaning components which contact hydraulic fluids is prohibited. Formation of a polymeric residue can result which could impair mechanical operation of the component.

(2) Replace filter element when signs of cracks or tears are noted. Replace filter screens that show signs of deterioration.

(3) Refer to the applicable aircraft maintenance manual for detailed assembly and maintenance requirements.

**4-12. Hydraulic System Filters.** Practically all foreign particles found in hydraulic fluid can be removed by filters. The degree of filtration needed depends on the acceptance level desired. Most high pressure hydraulic systems use filters having a 10- to 15-micron capability, but many later model aircraft have 5 micron filters; and two-stage filters, one



**Figure 4-95. Spherical Air Cylinder**

element of which has a 3-micron capability, are found in some recent models. They are intended primarily to safeguard the operation of certain important units by filtering out foreign particles generated by wear and tear of parts in the system. They cannot handle large quantities of foreign matter from outside the system. Uses of Filters in Hydraulic Systems. Filters are sometimes used in reservoirs. In addition, they may be located in the pressure line, in the return line, or in any other location where they are needed to safeguard the system against foreign particles in the fluid. However, filters are not normally used in system supply lines. There are many models of filters, the variation being necessitated by the location of the filter within the particular aircraft.

*b. Theory of Operation.* The size and shape of each element depend on its use and installation; however, all line filter assemblies are made up of three basic units: filter head, filter case, and filter element. Figure 4-96 shows a typical line filter assembly in which the differential pressure indicator is located in the top of the filter head assembly (in some designs the indicator is located on the side of the filter head assembly). Also located within the head is a bypass valve assembly which routes hydraulic fluid directly from the inlet to the

outlet port if the filter element becomes clogged with foreign matter. The filter case is the housing that holds the element to the head assembly and is the part that is removed during replacement of the filter element.

(1) *Normal flow.* Figure 4-97 shows a filter in normal flow. Hydraulic fluid enters the filter through the inlet port in the body and flows around the element inside the filter bowl. Filtering takes place as the fluid passes through the filtering element at the hollow core, leaving the dirt and impurities on the outside of the filter element. Filtered fluid then flows from the hollow core to the outlet port in the body and into the system.

(2) *Clogged filter.* Figure 4-98 shows a filter that is clogged. The bypass pressure relief valve in the body allows the fluid to bypass the filter element and pass directly through the outlet port. In most filters on this type, the relief valve is set to open if the pressure drop exceeds 50 psi, for example, if the pressure at the filter inlet port was 70 psi and the pressure at the outlet port dropped below 20 psi, the relief valve would open.

(3) *Differential pressure indicator.* Filters with a differential pressure indicator operate on the principle of difference in pressure entering the element and pressure after it leaves the element.

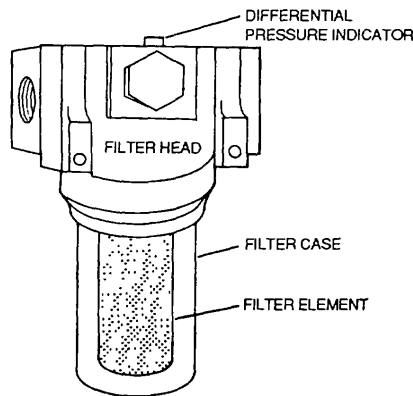


Figure 4-96. Fluid Filter Assembly

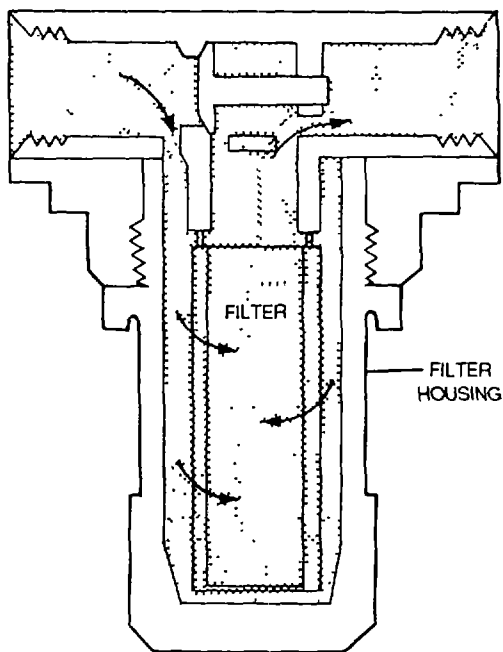


Figure 4-97. Fluid Filter (Normal Fluid)

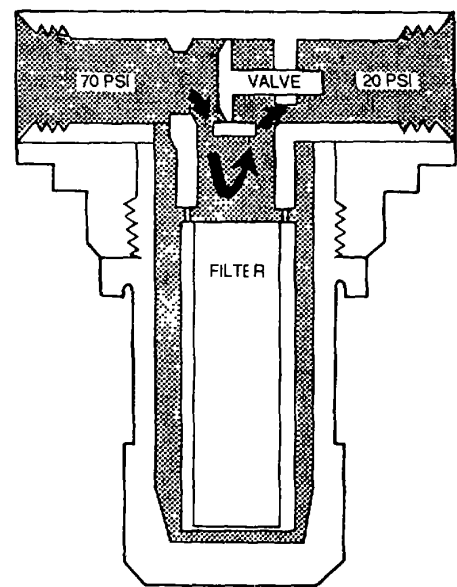
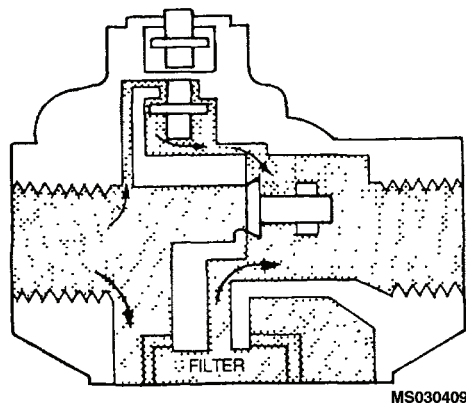


Figure 4-98. Fluid Filter (Clogged)

**(a) Operation.** Figures 4-99 and 4-100 show the indicator during normal flow and during bypass. As contaminating particles collect on the outside of the filter element, the differential pressure across the element increases. When this increased pressure reaches a specific value, inlet pressure forces the spring-loaded magnetic piston downward breaking the magnetic attachment between the indicator button and the magnetic piston. This allows the red indicator to pop out, showing that the element must be cleaned. Because increased fluid viscosity at low temperatures might cause a false indication of contamination, a low-temperature lockout of the differential pressure indicator prevents actuation at low temperatures.

**(b) Bypass.** If the filter element is not replaced when the indicator shows contamination, the filter element will continue to collect foreign particles and the pressure differential between the inlet and outlet ports will increase until the bypass valve opens and directs fluid through the filter element bypass. The use of a nonbypassing-type filter eliminates the possibility of contaminated fluid passing the filter element and contaminating the entire system. This type of filter will minimize the need for flushing the entire system and will lessen the chance for failure of pumps and other components in the power system.



**Figure 4-99. Differential Pressure Indicator (Normal Flow)**

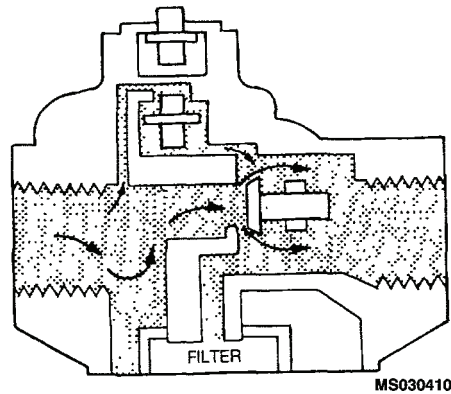
**c. Filter Elements.** The filtering elements in fluid filters are normally made of paper or of stainless steel. Paper elements are used mostly in low pressure systems and are thrown away when removed. Stainless steel elements are used in both high pressure and low pressure systems and may be reused.

**(1) Paper elements.** A typical fluid filter with a paper element is designed to remove 99 percent of all particles 10 microns (0.000394 inch) in diameter and larger. This element, like those used in the reservoir, is made of specially treated cellulose paper formed in accordion-like pleats to present the maximum filtering surface to the fluid.

**(a) Replacement criteria.** Paper filter elements are replaced on a scheduled basis, depending on the needs of the specific aircraft system. Unscheduled replacement of filter elements is also required following removal of certain components.

**(b) Removal and replacement.** The following procedure for removing and replacing paper filter elements is typical of most Army aircraft.

**1** Relieve system pressure by operating the main system bypass valve or by actuating a hydraulically operated unit.



**Figure 4-100. Differential Pressure Indicator (Clogged Filters)**

- 2** Depressurize reservoir (if necessary).
- 3** Cut lockwire.
- 4** Unscrew the filter case and remove it from the filter head, using a slight rocking and downward pull on the case after the case threads are free from the filter.
- 5** Extract the retaining ring and remove the filter element from the cases.
- 6** After ensuring that a replacement filter element is available, cut the filter element.
- 7** Before installing the new filter, clean the filter head and the filter case and inspect them for damage; replace all damaged parts.
- 8** Replace all O-ring packings.
- 9** Fill the filter bowl with new fluid before attaching it to the filter housing head. Filling the bowls helps to stop the injection of air into the system.
- 10** Install the filter in its case and screw the case into the filter head. The correct torque is usually handtight plus one-eighth of a turn, but always check the specific maintenance manual for the specific torque value.
- 11** Pressurize the hydraulic system and inspect the filter assembly for leaks. If the assembly is Satisfactory, replace the lockwire between the filter case and the head assembly.

**(2) Stainless steel elements.** Stainless steel filter elements are used in most modern aircraft. Filter element surfaces of this type usually have a corrugated stainless steel mesh construction. Such filters are usually rated from 5- to 10-micron nominal flow and at 25-micron absolute flow. This means about 95 percent of 5- to 10-micron particles and 100 percent of 25-micron particles will be filtered from the fluid. The curved passages of the filter element limit the length of the particles that pass through the filter.

**WARNING**

Degreasing solvent, MIL-PRF-680, is combustible and toxic to eyes, skin and respiratory tract. Wear protective gloves and goggles/face shield. Avoid repeated or prolonged contact. Use only in well ventilated areas (or use approved respirator as determined by local safety industrial hygiene personnel). Keep away from open flame other sources of ignition.

**CAUTION**

Under no condition shall a wire brush be used in cleaning filter element. Failure to comply will result in possible failure of equipment.

**CAUTION**

The use of any alcohol in cleaning components which contact hydraulic fluids is prohibited. Formation of a polymeric residue can result which could impair mechanical operation of the component.

(a) Wash filter element in degreasing solvent, MIL-PRF-680, using a soft lint-free cloth. Allow to drain, and dry with low pressure compressed air.

(b) Replace filter element when cracks, tears, and other signs of deterioration are noted.

**d. Two-Stage Fluid Filters.** Two-stage line-type hydraulic system filters are being used in some recent aircraft models. The typical two-stage filter has two filter elements, two bypass valves, and two differential pressure indicators. The first-stage element can filter out smaller particles than the second-stage element can. Normally, the fluid passes through both elements, flowing first through the first stage element. As long as the first stage element is unclogged and functioning, there will be no foreign matter left for the second-stage element to remove. However, if the first-stage element becomes clogged, its bypass valve opens and fluid goes directly from the filter inlet port to the second-stage element, which then takes over the job of filtering out foreign particles. Although the second-stage element is not capable of filtering out the very small particles, it can be safely used until the first-stage element is unclogged.





e. **Air Filters.** An air filter is usually located in the line leading into the system supply source. Additional filters may be located at various points in the system lines to remove any foreign matter that may enter the system. Like hydraulic filters, air filters have a removable element and a built-in relief valve. The relief valve is designed to open and bypass the air supply around the filter element in case the element becomes clogged. Some air filters are equipped with a paper-type element which must be replaced periodically. Others have a screen mesh-type which requires periodic cleaning. The screen mesh-type may be returned to the system after being cleaned and dried.

f. **Servicing Filters,** Filters should be serviced in accordance with schedules and procedures contained in technical manuals pertaining to the specific aircraft involved. However, the following general guidelines apply to the servicing of all aircraft hydraulic system filters:

(1) Handle filters carefully. A hole no larger than a pinprick will permit large foreign particles to pass through the element.

(2) Service filters in a clean area; this will help keep dirt and other foreign particles from entering the system while the filter is being serviced.

(3) Do not leave a disassembled filter housing unprotected because this may cause contamination.

(4) Remove wrappings from a replacement element only when the element is to be inspected or installed.

(5) The filter bowl should only be hand tightened to the head. Always safety the bowl and head together

(6) Be sure that a popped-out Indicator button is indicating the need to service the filter. Push the button back in with the system at normal operating pressure. If the button pops out again, the filter needs servicing; if it stays in, the filter is not clogged.

**4-13. Pumps and Motors.** The hydraulic pump is the mechanism for transferring and pressurizing aircraft hydraulic fluid. Aircraft systems use engine-driven power pumps for this purpose. Hand pumps are also provided as emergency equipment and for ground checking the hydraulic system. Hydraulic motors in Army aircraft perform such functions as landing gear retraction and extension and operating cargo ramps, doors, and winch hoists.

a. **Power Pumps.** The primary energizing unit of the hydraulic system is the power pump. It is the unit that normally delivers hydraulic fluid under pressure to the actuators. Power pumps may be driven by an electric motor, a turbine unit, or the aircraft engine; however, engine-driven pumps are used in all Army aircraft at this time. The piston type power pumps used in modern hydraulic systems run at a rated speed of about 1 1/2 times engine crank-shaft speed. In the drive shafts of all power pumps, there is a thinned portion that provides for a shearing action. If the pump seizes, the shaft will break at this point, thus preventing damage to the engine or the transmission.

(1) Bent-axis constant-volume pumps. Constant-volume piston-type pumps put out a constant flow of fluid for any given rpm. The pistons (usually seven or nine in number) are fastened by universal linkage to the drive shaft, as shown in figure 4-101. The universal link (2) in the center drives the cylinder block (4). This block is held at an angle to the drive shaft (1) by the housing. Pumps are available with different angles between the drive shaft and the cylinder block; a large angle provides more output volume per revolution because the larger angle increases the piston stroke

(a) Theory of operation. Figure 4-102 illustrates the theory of operation. As the drive shaft (1) rotates the cylinder block (4) and the piston assemblies, all the pistons are always the same distance from their points of attachment (3) on the drive shaft. Although the pistons appear to move within the cylinders, it is actually the cylinders that move back and forth around the pistons as the block and piston assembly rotates. Figure 4-103 shows a pump with pistons on intake and pressure strokes. Piston (1) is at the top of its cylinder,

having just completed its pressure stroke and ready to being its intake stroke. As the block starts to rotate from this point, the piston becomes aligned with the intake port (3). When the block has turned one-half of a revolution, the piston reaches the bottom of the cylinder (4). The cylinder space formerly occupied by the piston is now full of fluid. As the block continues to rotate, the piston becomes aligned with the outlet port (2) Having now moved through the last 180 degrees of rotation, it has exhausted all fluid from the cylinder and is ready to make another cycle. Since several pistons are operating as described and since the cylinder block and piston assembly rotate rapidly, there are always pistons somewhere between the upper and lower positions. This ensures a constant intake and output of fluid

(b) Cooling and lubrication. The piston-type pump uses case pressure for cooling and lubrication. Fluid seeps by the pistons in the cylinder block and fills all the space inside the pump. This fluid cannot escape through the drive end of the pump because of a seal around the drive shaft. Excess case pressure within the housing is routed back to the intake side of the pump. This is done through a relief valve called a foot valve (figure 4-104). This valve prevents the case pressure from rising above approximately 15 psi Drilled passageways through the universal link rods help to keep the rod ball end lubricated

(2) Variable-volume pumps A variable volume pump has some advantages. One is that its use does away with the need for a pressure regulator or an unloading valve Integral flow control valves regulate the pressure according to the demands made on the system A second advantage is that pressure surges are reduced. Accumulators are not needed to smooth out surges with systems using variable-volume pumps, but they are retained to aid the pump when peak loads occur.

(a) Stratopower effective stroke pumps. As shown in figure 4-105, the drive shaft (1) rotates the cam (3). This cam causes the nine spring-loaded pistons (4) to move back and forth in their cylinders, which are in a stationary cylinder block. In operation, each piston is forced into and removed from the cylinder once for each revolution of the cam. The pistons are held in contact with the cam by piston springs, which also return the pistons after each forward or power stroke Each piston has a half-ball bearing surface which acts like a universal linkage The flat side contacts the cam during all angle changes. The pistons have fairly large hollow centers, connected with cross-drilled holes. Around each piston there is a sleeve (5) attached to a spider (6), which in turn is attached to the compensator (7). An increase in pressure moves the compensator to the right Decreased pressure allows it to move to the left because of the valve spring tension. As the pistons travel to the left, fluid drawn from the inlet port (12) passes through the open center of the cylinder block and then into the cylinders (13) At this point, hydraulic fluid fills the center of the pistons. Some fluid will continue to flow out through the cross-drilled holes and on to the pump return port (2) on the drive end of the pump. As the pistons are forced to the right by the cam (3), the cross-drilled hole of each piston is blocked off by its sleeve About the time that the cross-drilled passage is blocked off, the supply annulus (8) that surrounds the cylinder is also blocked off. This condition traps the fluid in the piston and cylinder. As the piston continues on to the right, pressure builds up against the check valve (10). Fluid under pressure goes out the check valve into the pressure chamber (9) and through the outlet port (11). When the piston moves as far right as possible, the cycle starts all over again. This cycle is the same for all nine pistons.

1 Zero flow. (See figure 4-106). As pressure rises in the pressure outlet line, it is also felt in the passageway (14). This pressure acts on the compensator (7), forcing it to the right. This compresses the spring and carries the spider and sleeves (6 and 5) with the compensator. The more the sleeves move to the right, the farther each piston travels before the cross drilled passage is covered. This means that less fluid is trapped by the right end of the piston for output to the pressure manifold. The maximum setting of the compensator is all the way to the right. Then the output to the pressure manifold drops to zero, as shown In figure 4-106 In this condition, all intake of the pump goes out the return port (2) Rotation of the cam draws fluid through the pump for cooling and lubrication There is always fluid being pumped through the inlet port. But fluid will not be pumped through the outlet port until system pressure drops low enough to demand it. Always connect the proper lines to the ports marked IN, OUT, and RETURN

2 Pressure regulation. The stratopower pump does not require a pressure regulator The compressor serves nearly the same purpose Pressure can be increased by turning the adjusting screw (15, figure 4-106) clockwise or decreased by turning it counterclockwise

(b) *Vickers stroke-reduction pump.* (See figure 4-107). The Vickers stroke-reduction pump operates somewhat like the constant volume piston-

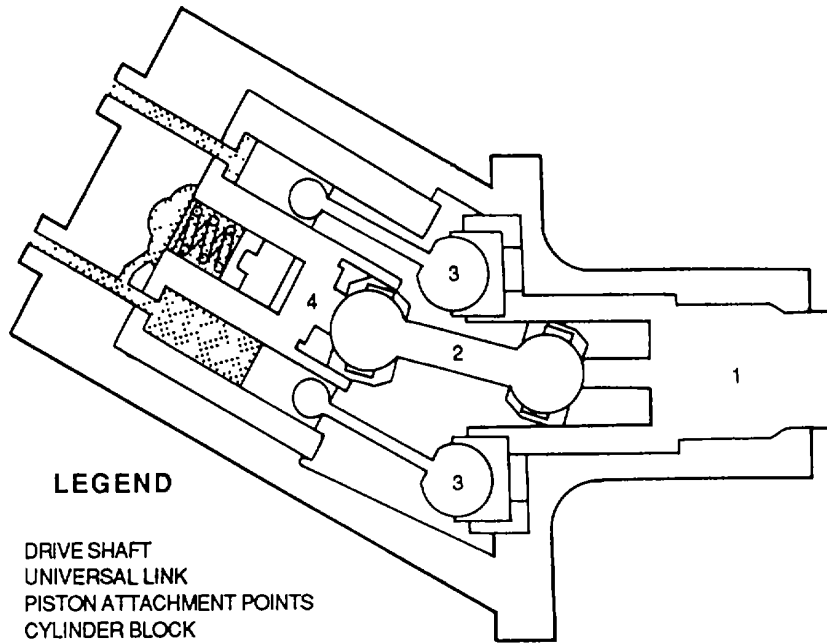


Figure 4-101. Bent-Axis Constant Volume Pump

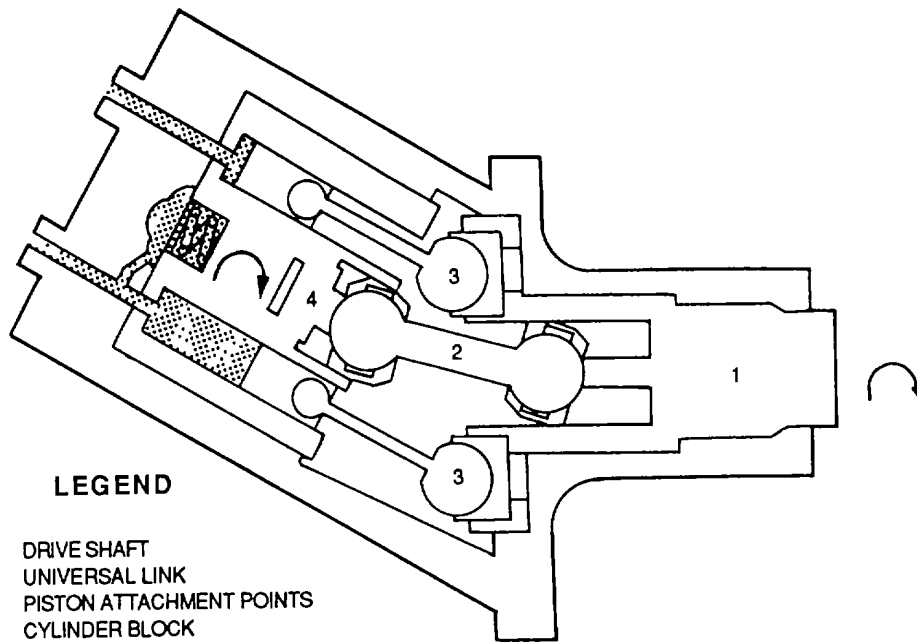
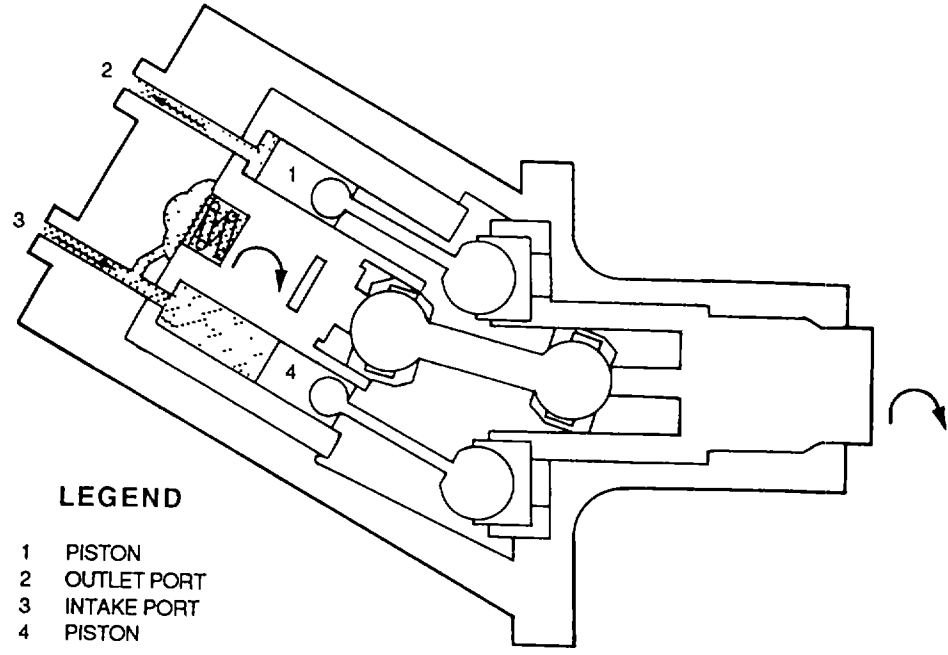
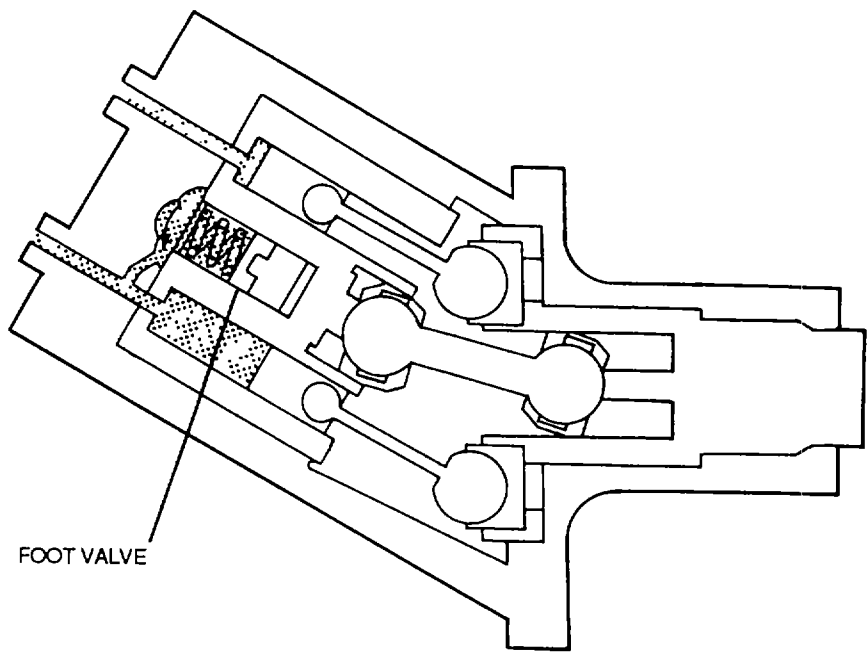


Figure 4-102. Constant Volume Pump (Piston Installation)



**Figure 4-103. Constant Volume Pump (Piston Operation)**



**Figure 4-104. Constant Volume Pump Foot Valve**

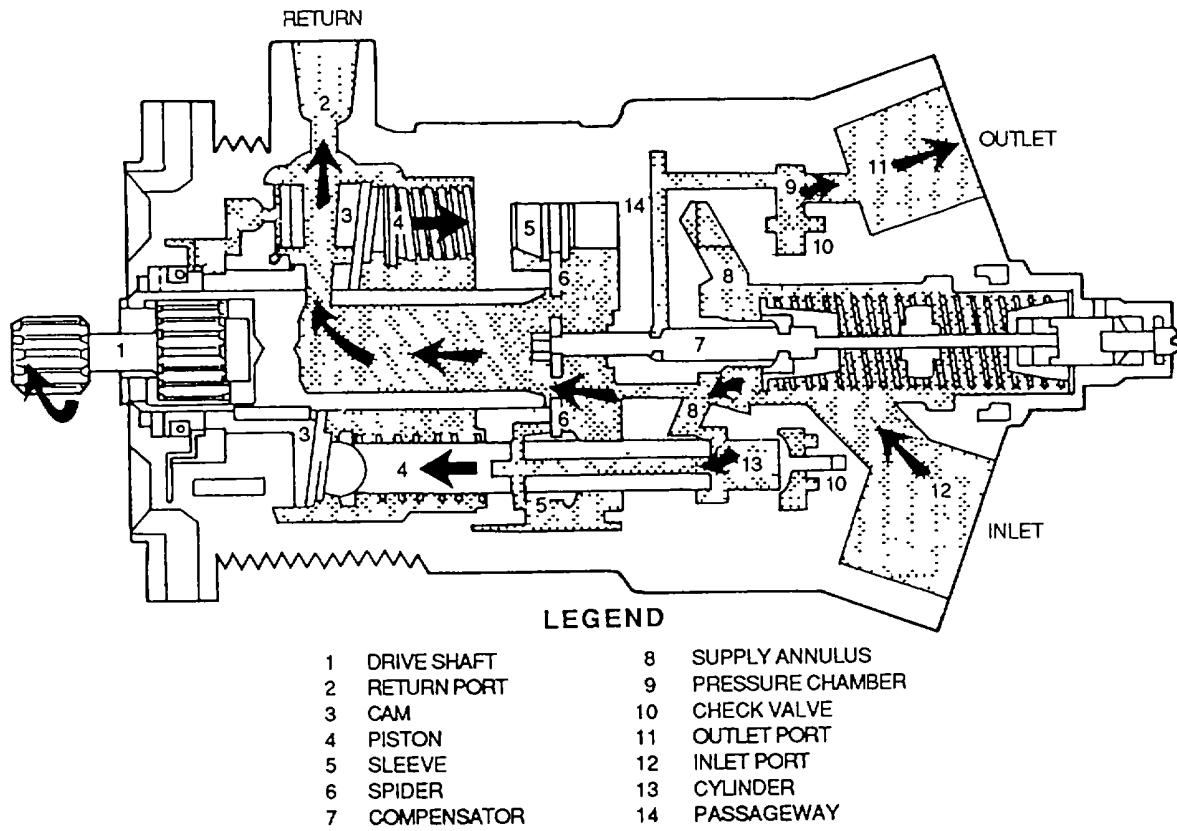


Figure 4-105. Stratopower Effective Stroke Pump (Full Flow)

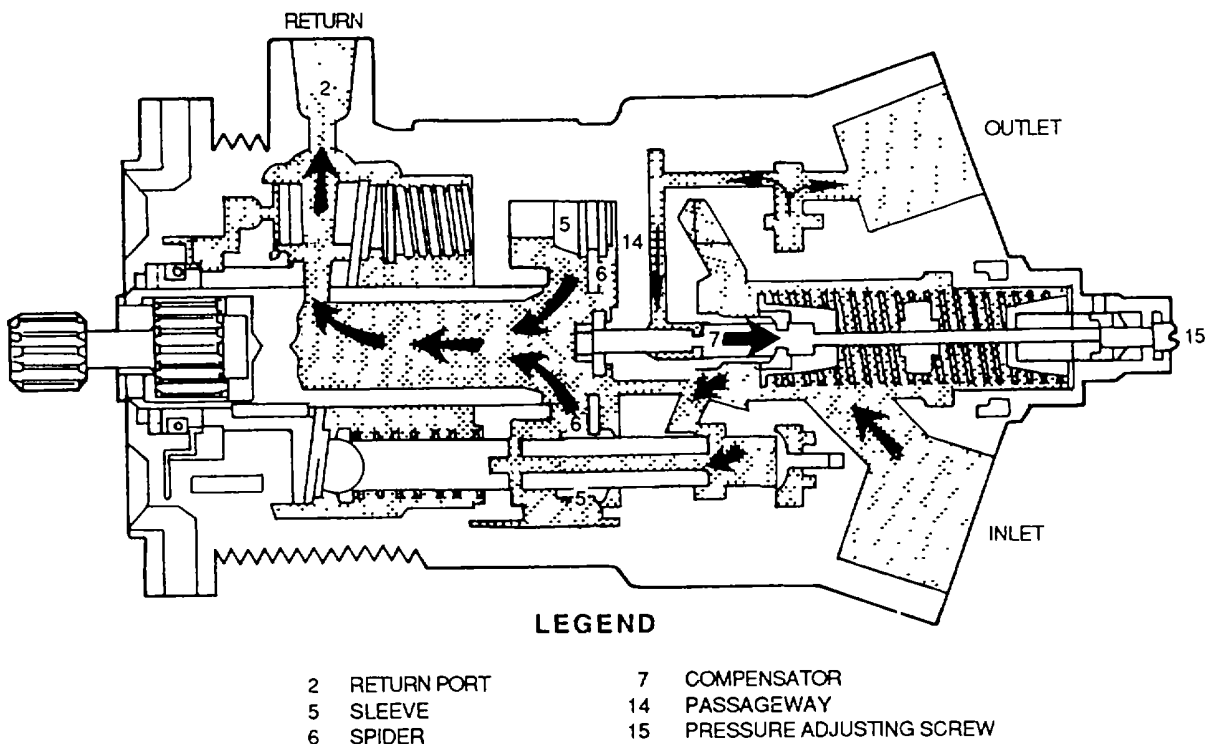
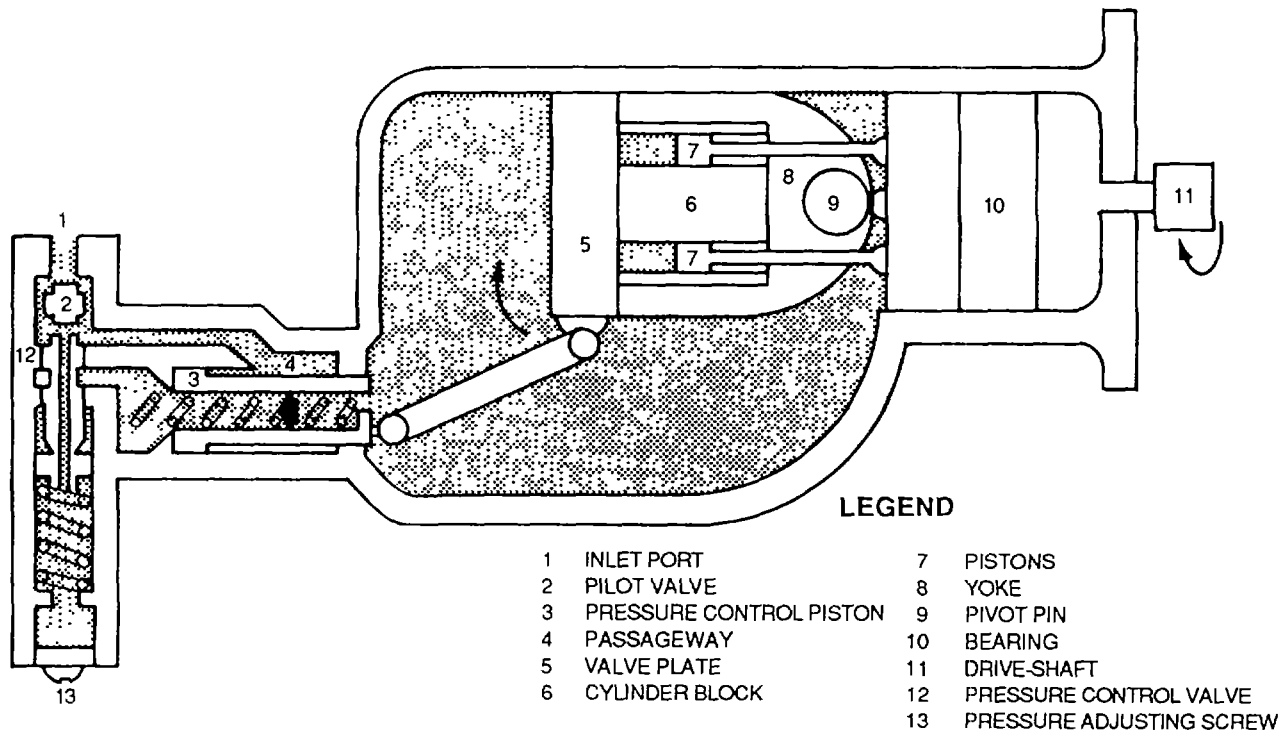


Figure 4-106. Stratopower Effective Stroke Pump (Zero Flow )



**Figure 4-107. Vickers Stroke Reduction Pump (Zero Flow)**

type pump The main difference between the two types is the angle between the drive shaft and the cylinder block. In the constant-volume pump, this angle is fixed; In the Vickers pump, the angle vanes automatically to satisfy the pressure-volume demands of the system.

**1 Zero Flow** (See figure 4-107). In the stroke-reduction pump, the drive shaft (11), the pistons (7), and the cylinder block (6) are all supported by the bearing (10) and they all rotate. A yoke (8) contains the cylinder block, which swivels around the pivot pin (9). Before the pump builds up any pressure, the yoke is held by the spring. In the pressure control piston (3) in the position shown in the full-flow illustration (see figure 4-106). When outlet pressure is at maximum, the yoke is held in the position shown in figure 4-107. As long as there is no pressure in the system, the cylinder block and yoke are in the extreme angle position. System pressure entering the connecting line (1) acts on the pilot valve (2), pushing it down against the spring toward the zero flow position. This opens the passageway (4), sending pressure against the rod side of the pressure control piston (3). As the piston moves to the left, its spring is compressed. This force, which is transmitted through the valve plate (5), causes the yoke to swivel upward so that the cylinder block moves toward a zero angle. If the cylinder block reaches the extreme zero flow point, there is no fluid output to the system. This is because the pistons have no stroke in the cylinder block

They simply rotate with the cylinder block without moving back and forth

**2 Full flow.** As the pressure in the system starts to drop, its force on the pilot valve is reduced. When this happens, the spring under the pilot valve moves it upward. This reduces the opening to the passageway and cuts down the pressure on the pressure control piston so that its spring pushes it to the right. Now the yoke swivels downward, causing the stroke of the pistons to increase. The pressure and volume output again start to increase until the system's demands are met (see figure 4-108). The action of the pressure control valve (12) stabilizes the position of the cylinder block (6). Its angle adjusts to meet the system demands. Notice that the hollow center of the pressure control piston is vented to the inside of the case (14) so that fluid trapped inside the piston can escape to the case. A foot valve (not shown) prevents case pressure from becoming too high.

**3 Pressure regulation.** Pressure is increased or decreased by turning the adjusting screw (13, figure 4-108). An internal relief valve prevents damage in case the pressure control valve fails to function properly

(c) Kellogg stroke-reduction pump The Kellogg pump shown in figure 4-109, is made up of two

major component groups the rotating group and the pressure-compensating group. The rotating group consists of the drive shaft (2), the cylinder barrel (4), nine pistons (3) with their piston shoes and locking plates (1) The pressure-compensating group consists of a cam plate (6), a compensator valve (8), and a control piston (7). The cylinder barrel is supported in the housing by a roller bearing (5). The drive shaft passes through but does not touch the inclined cam plate to rotate the cylinder barrel unit. Pistons of the rotating group are actuated by tilting the non rotating cam plate The contact is a universal action type, consisting of hydraulically balanced shoes and locking plates The length of piston stroke is determined by the angle of the cam plate maximum pump output requires a high angle; zero pump output requires a flat angle setting

1. Full flow. In figure 4-109, the lower piston is shown near the beginning of the intake stroke. As the cylinder unit is rotated, the piston moves to the left in its cylinder. For nearly one-half of a revolution, the face port of this cylinder is aligned with the annulus connected to the fluid inlet (10) Hydraulic fluid is sucked into the cylinder as the piston is withdrawn just after passing the end of the inlet annulus. Further rotation forces the piston to the right and aligns the cylinder with the annulus connected to the outlet port (9) and to the compensator valve (8). In this position, fluid is forced from the piston. This discharge stroke lasts until the cylinder and piston reach the bottom position and are ready to begin another intake stroke. At the same time, there are eight other pistons on the intake and discharge strokes, all doing the same thing. Their pumping action continues until the fluid needs of the system are satisfied.

2. Zero flow. When a subsystem actuator completes its travel, the need for pump output is reduced to zero. The pump senses the end of the actuator travel because the unused output causes a sudden increase in discharge pressure. As this pressure reaches the setting of the compensator valve, it pushes the valve to the right (see figure 4-110). The pressure then pushes on to the control piston, causing it to move to the left and decreasing the angle of the cam plate. This action decreases the effective length of the piston stroke, thus decreasing the volume of fluid delivered to the system. In actual operation, the cam

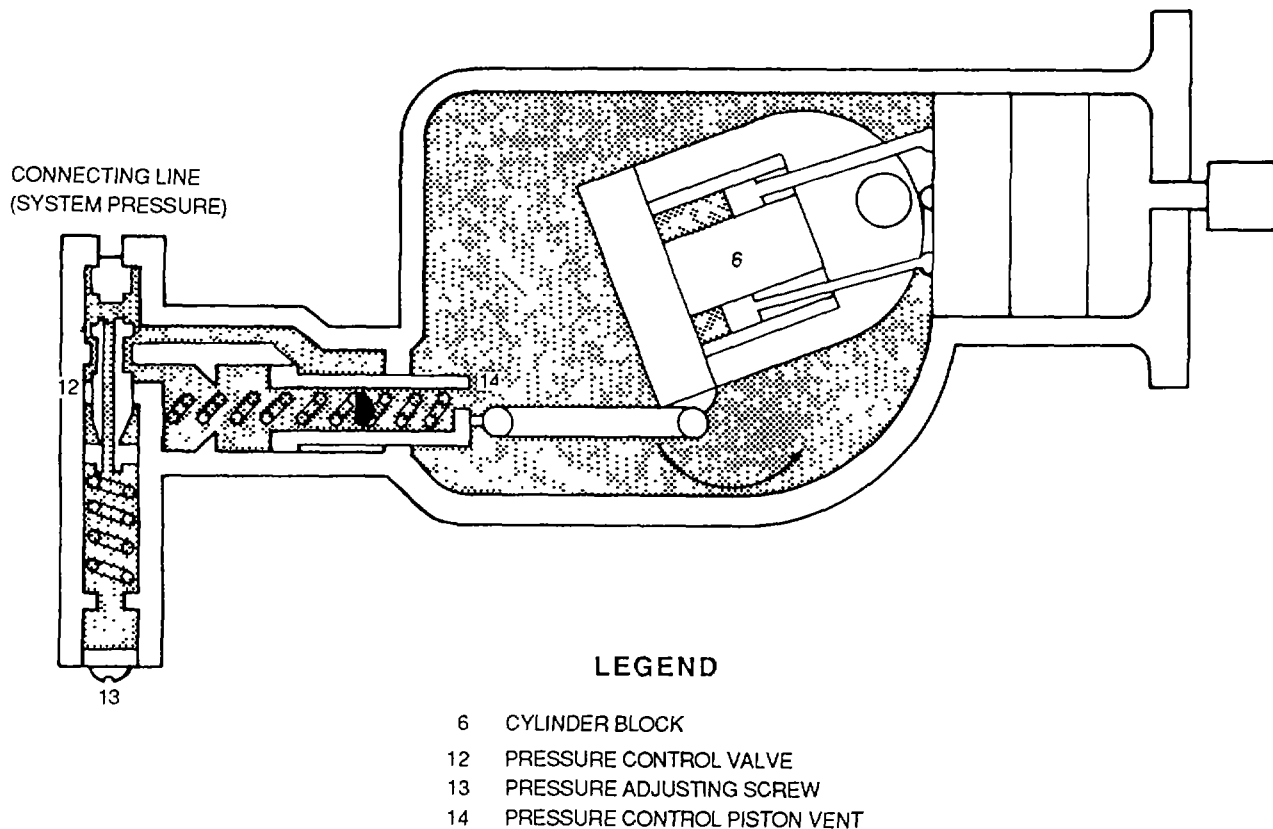
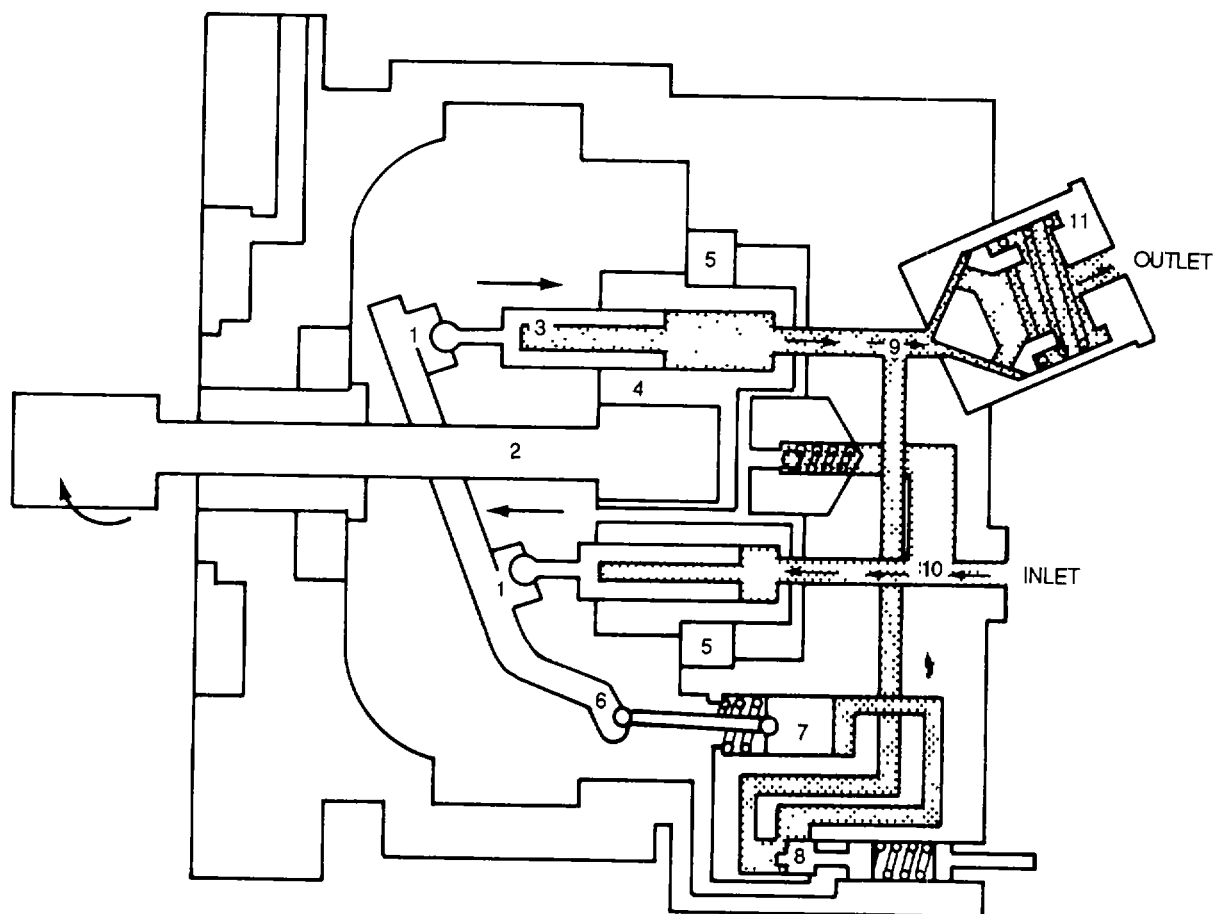


Figure 4-108. Vickers Stroke Reduction Pump (Full Flow)

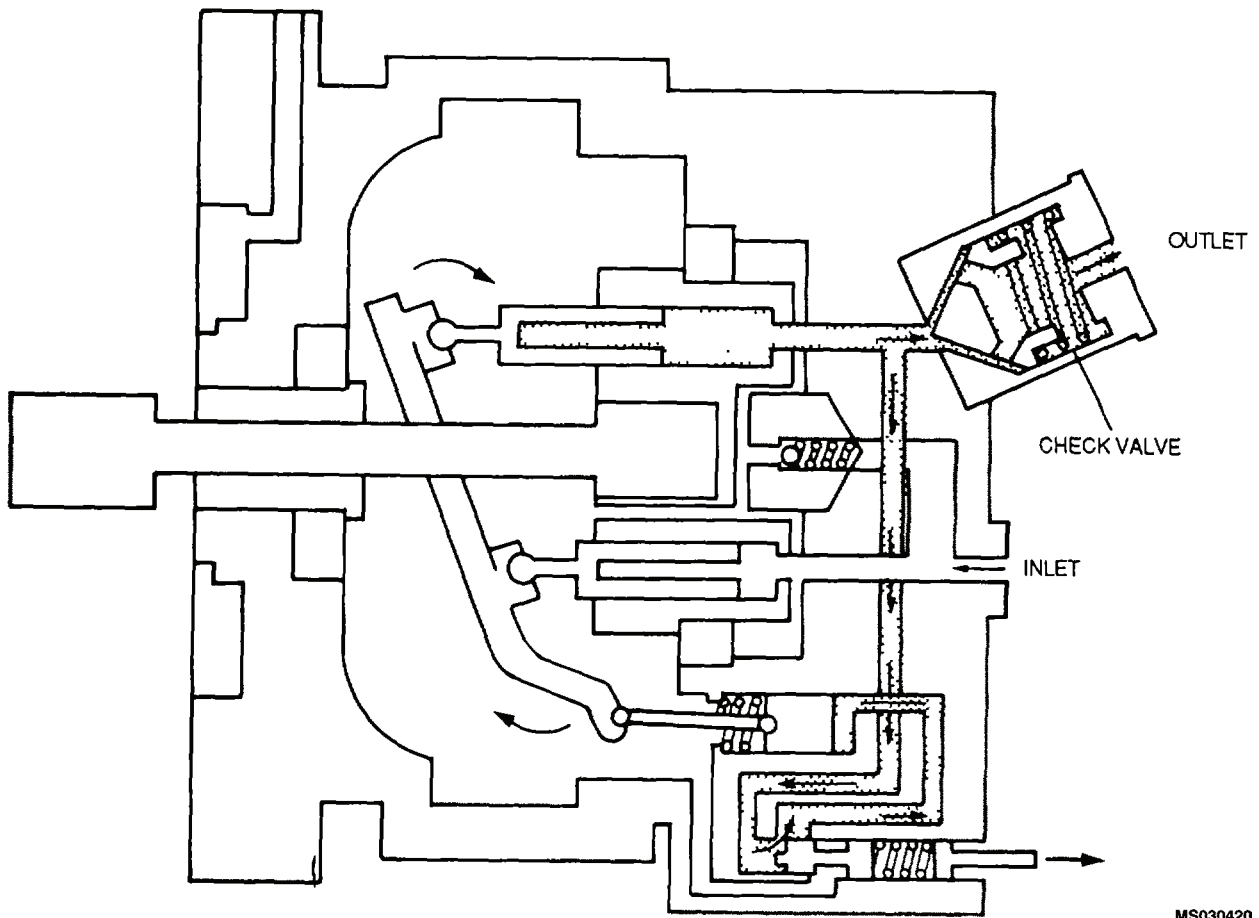


**LEGEND**

- 1 PISTON SHOE AND LOCKING PLATE
- 2 DRIVE SHAFT
- 3 PISTON
- 4 CYLINDER BARREL
- 5 ROLLER BEARING
- 6 CAM PLATE
- 7 CONTROL PISTON
- 8 COMPENSATOR VALVE
- 9 OUTLET PORT ANNULUS
- 10 FLUID INLET ANNULUS
- 11 OUTLET CHECK VALVE

**Figure 4-109. Kellogg Stroke Reduction Pump Assembly**





**Figure 4-110. Kellogg Stroke Reduction Pump (Reduced Output)**

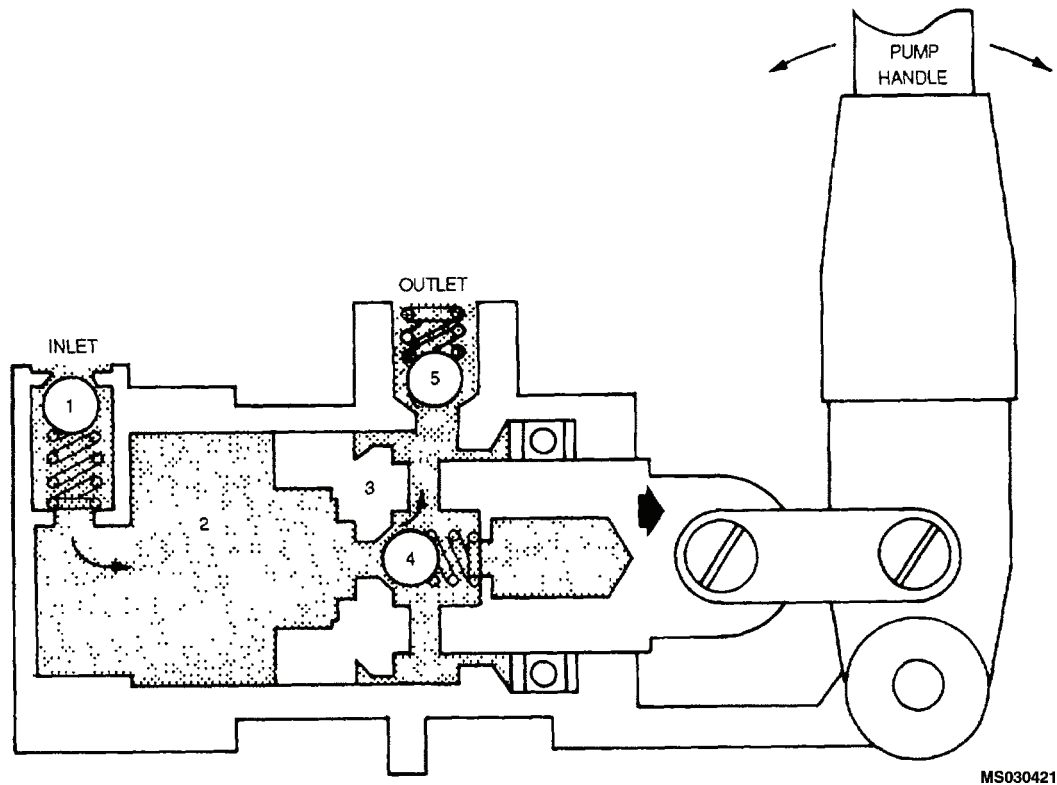
plate assumes various angles to maintain the proper system pressure. It will meet all fluid demand conditions within the rating of the pump. A pump check valve installed in the pump outlet line prevents return flow into the pump during operation of the system with a portable test stand. Reverse flow of hydraulic fluid would motorize the pump.

**b. Maintenance of Power Pumps.** Repair and overhaul of hydraulic power pumps is done at depots. This work requires special tools and equipment.

**c. Hand Pumps.** Hand pumps serve as replacements for power pumps during emergencies in flight and as sources of power for checking the hydraulic system when the aircraft is on the ground. They are piston-type pumps and may be either single or double action; however, most are the double-action type. Such pumps deliver fluid under pressure on both the fore and aft strokes of the piston.

**(1) Description.** The hand pump shown in figure 4-111 consists essentially of a cylinder assembly containing a piston (3) and two spring loaded check valves (5 and 4). When the piston moves to the right, the piston check valve (4) is held closed by the spring. The piston forces the fluid in the right chamber (5) out into the pressure line through the check valve. At the same time, the suction effect created in the left chamber (2) by the moving piston draws fluid through the inlet line check valve (1), thus filling that chamber. When the piston moves to the left, the inlet line check valve is held closed by the pressure of the fluid in the left chamber. The space available for the fluid in the right chamber is now less than the space in the left chamber. This is caused by the piston rod displacement in the right chamber; the excess fluid under pressure is driven out through the discharge port of the system.

**(2) Maintenance.** Maintenance of hand pumps consists of disassembly, inspection, reassembly and testing.



- |                      |                |
|----------------------|----------------|
| 1. INLET CHECK VALVE | 4. CHECK VALVE |
| 2. PUMP CHAMBER      | 5. CHECK VALVE |
| 3. PISTON            |                |

Figure 4-111. Double-Action Hand Pump

**WARNING**

Degreasing solvent, MIL-PRF-680, is combustible and toxic to eyes, skin and respiratory tract. Wear protective gloves and goggles/face shield. Avoid repeated or prolonged contact. Use only in well ventilated areas (or use approved respirator as determined by local safety industrial hygiene personnel). Keep away from open flame other sources of ignition.

**CAUTION**

The use of any alcohol in cleaning components which contact hydraulic fluids is prohibited. Formation of a polymeric residue can result which could impair mechanical operation of the component.

**(a) Disassembly.** Carefully disassemble the pump and thoroughly clean all parts with degreasing solvent, MIL-PRF-680. Dry with clean, dry compressed air.

**(b) Inspection.** Inspect all parts for nicks, cracks, scratches, and corrosion. Inspect threaded surfaces for damaged threads and piston shaft and springs for distortion. Check the valve poppets for proper seating.

**(c) Reassembly.** Replace all non-repairable parts and natural or synthetic rubber items, such as O-rings or packings. Remove minor scratching or corrosion by polishing with crocus cloth. If necessary, clean internal and external threads with the appropriate size tap or die. Coat all internal parts with the appropriate type hydraulic fluid prior to assembly.

(d) *Testing.* After the pump has been reassembled, test it for proof pressure and leakage. Figure 4-112 illustrates a simplified setup for testing the hand pump.

1 *Proof pressure.* To test for proof pressure, pump fluid through the circuit with the pump connected and the shutoff valve open. This bleeds all air from the system. Next, close the shutoff valve and operate the pump to obtain the required proof pressure. Proof pressure is approximately 1-1/2 times normal operating pressure. Control the strokes so that the final stroke will leave the piston in the retracted position, after which pressure should be maintained for a specified time (usually 2 to 5 minutes). Repeat the preceding step, this time controlling the strokes so that the final stroke will leave the piston in the extended position.

2 *Leakage test.* For the leakage test, use the pump to pressurize the circuit to the normal operating pressure (the shutoff valve is closed during this check). The pressure must hold for a specified period of time (approximately 2 minutes). There should be no piston creep, and the pressure drop should not exceed the specified amount (usually 50 to 100 psi).

3 *Completion of testing.* After completion of testing, relieve the pressure and remove the pump from the test circuit. Drain the pump to the drop point. Then refill it with the specified preservative fluid to about 90 percent of its capacity. Plug all ports and closures and mark the rubber parts cure date of the pump

d. *Hydraulic Motors.* Motors operate on the same principle as power pumps, but in reverse.

(1) *Applications.* Figure 4-113 shows a variable-displacement, axial-piston, rotating-cylinder-block unit. It delivers a minimum of 16.6 horsepower at 8,000 rpm. This particular motor is used to drive an ac-dc generator at a constant rpm. Since an ac generator or alternator must put out the same number of cycles per second under all load conditions, a very sensitive flyweight governor is required on the motor. For components where the rpm is not critical, a constant-displacement-type hydraulic motor would probably be used.

(2) *Operation.* When the hydraulic system is pressurized, fluid pressure is put on the pistons of the cylinder block. Pressure must also go to the closed starting valve of the motor. Normal system pressure will sustain cylinder and generator rotation, but higher pressure is needed to start the rotation.

(a) *Starting.* Starting is accomplished by the starting valve (6). When system pressure builds up to 1,800-2,200 psi, the starting valve is moved to the right as shown. This action permits fluid under pressure to move the control piston (9). The control piston moves the bottom of the wobbler plate (8) to the right with sudden force. Movement of the wobbler kicks the upper and lower pistons (7) to give the cylinder block an initial spin. Thereafter, system pressure maintains rotation of the cylinder block. As hydraulic pressure continues to increase, motor speed increases. As the rotational speed increases, the governor flyweights (3) begin to pivot outward, moving the governor control valve (4) proportionately to the left. This movement gradually blocks the pressure to the control piston. When the passage is completely blocked, pressure is no longer put on the control piston and motor speed ceases to increase. This is referred to as an on-speed condition.

(b) *Load control.* The load imposed on the motor varies with the electrical load on the generator. To meet the changing demands, the motor must vary its torque to maintain its normal operating speed. Let us assume that the motor tends to overspeed.

1 *Overspeed.* The overspeeding causes the governor flyweights (3) to move outward, pulling the governor control valve (4) a little bit to the left. Movement to the left from the blocked position vents the control piston (9) passage to return system pressure. This reduces the force acting on the control piston. Now system pressure acting on the upper piston (7) is greater than the return system pressure on the control piston. The result is that the upper piston in the rotating cylinder block moves the wobbler plate (8) toward the right, thus reducing the angle of the wobbler plate. The reduced angle reduces the torque output and consequently the speed of the motor.

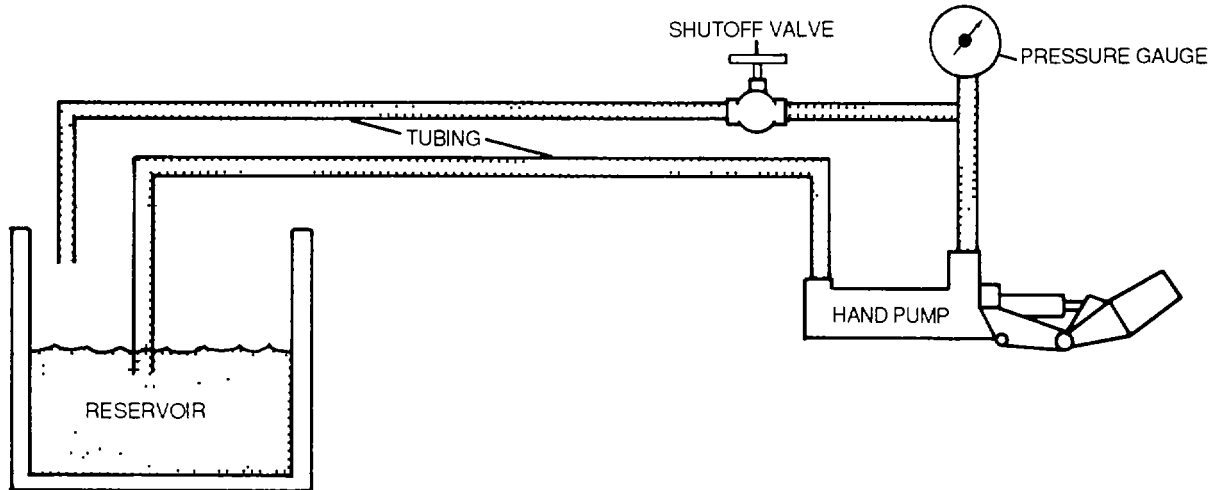
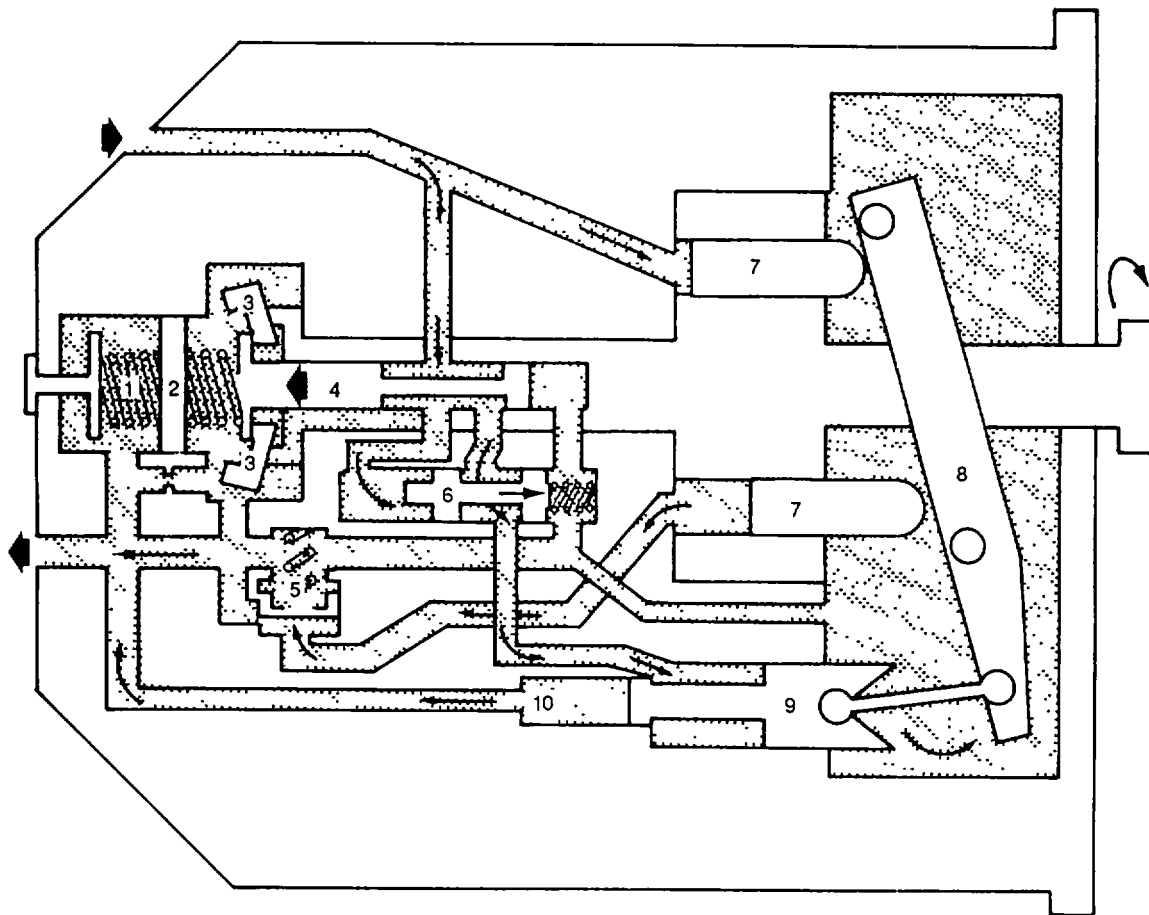


Figure 4-112. Hand Pump Test Circuit



LEGEND

- |   |                        |    |                |
|---|------------------------|----|----------------|
| 1 | GOVERNOR SPRING        | 6  | STARTING VALVE |
| 2 | PREACT PISTON          | 7  | PISTON         |
| 3 | GOVERNOR FLYWEIGHT     | 8  | WOBLER PLATE   |
| 4 | GOVERNOR CONTROL VALVE | 9  | CONTROL PISTON |
| 5 | BACK PRESSURE VALVE    | 10 | FEEDBACK LINE  |

Figure 4-113. Hydraulic Motor

2 *Activation of flyweight governor.* Movement of the wobbler plate also momentarily activates the preact piston (2) of the flyweight governor. This prevents over-travel of the governor control valve and hastens the motor's response to changes in load. The preact piston acts when the wobbler plate moves to the right and the control piston moves to the left. This action forces fluid in the feedback line (10) into the chamber on the left side of the preact piston. When fluid moves into this chamber, the preact piston moves to the right, increasing tension on the governor spring (1) and opposing movement on the governor control valve to the left. Motor speed decreases and the fluid in the preact piston chamber bleeds off through the restrictor bleed. The governor control valve moves back to the right, blocking the control piston passage and holding the wobbler plate in its new position. These events occur almost instantly to match torque requirement with the load.

3 *Back pressure valve.* A back pressure valve (5) is installed in the discharge line of the lower piston to prevent the piston from floating and chattering. If this valve were not in the return line, return pressure would exist on both sides of the lower pistons. Under this condition, the pistons would tend to float. The back pressure valve puts 100 psi over return pressure load on the back side of the lower pistons. This load holds them against the wobbler plate and prevents chattering.

(3) *Maintenance.* Repair and overhaul of hydraulic motors are done at depots. This work requires special tools and equipment.

**4-14. Devices for Regulating Pressure.** Devices for regulating pressure in aircraft hydraulic systems include pressure gauges, pressure switches, relief valves, and pressure reducing valves.

a. *Pressure Gauges.* Hydraulic pressure gauges indicate the amount of pressure in a hydraulic system. Gauge dials are calibrated to display this pressure in pounds-per square inch (psi). Direct-reading and remote-indicating gauges are the types used.

(1) *Direct-reading gauges.* The direct-reading gauge shown in figure 4-114 consists essentially of a Bourdon tube, a pointer, a dial, and a raintight case. The Bourdon tube and the pointer are interconnected by gearing to cause them to move together. Pressure within the hydraulic system is admitted into the Bourdon tube through a connecting line. As hydraulic system pressure increases, it causes the Bourdon tube to straighten to a corresponding degree. The change in curvature of the tube reacts on the gearing, causing the pointer to move to a correspondingly higher reading on the dial. As hydraulic system pressure decreases, the Bourdon tube curls back toward its original shape by a corresponding amount. This causes the pointer to fall back to a correspondingly lower dial reading. Pressure gauge snubbers are usually used with hydraulic pressure gauges to dampen oscillations of the pointer.

(2) *Remote-indicating gauges.* In the remote-indicating gauge, the gauge transmitter contains a Bourdon tube diaphragm, or bellows, to which hydraulic system pressure is admitted through a connecting line. The Bourdon tube diaphragm reacts to pressure changes in a manner similar to that of the direct-reading type gauge. Movements of the diaphragm produce electrical signals that are transmitted through connecting wiring to the indicator unit, where they cause the indicator pointer to move. Some aircraft systems have a direct-reading gauge in a location in the system in addition to a remote-indicating gauge. In the event a remote-indicating gauge indicates a possible problem, always check the direct-reading gauge to confirm whether the gauge or the system is at fault.

b. *Pressure Switches.* A pressure switch is designed to open or close an electrical circuit in response to a predetermined hydraulic pressure entering the switch from a connected source. Piston-type and diaphragm-type pressure switches are the types commonly used in Army aircraft.

(1) *Piston-type.* The piston-type pressure switch shown in figure 4-115 consists of a rectangular shaped housing, a cylinder bore and piston, an adjustable spring for loading the piston, a microswitch and a linkage for transmitting movement of the piston to the microswitch. The housing has a port for connecting the switch to a system pressure line and an electrical receptacle for connecting the switch with an electrical circuit.

(2) *Diaphragm-type.* The diaphragm -type pressure switch consists of a cylindrical-shaped housing a diaphragm, an adjustable spring to load the diaphragm, a microswitch, and linkage for transmitting movements of the diaphragm to the microswitch. The housing has a port at one end for connecting the switch to a system pressure line and an electrical receptacle for connecting the switch with an electrical circuit at the other end.

(3) *Operation.* The operation described here covers the piston-type pressure switch. However, the diaphragm switch operates on essentially the same

principles. Fluid pressure entering the port of the pressure switch acts on the face of the piston to move it against the resistance of the piston return spring. When the fluid pressure acting on the piston becomes great enough to overcome the force of the piston return spring, movement of the piston causes the pivoted lever of the connecting linkage between the piston and the micro-switch to rotate. The movement of the pivoted lever is transmitted through the Idler spring to the actuating button of the microswitch. When the microswitch actuating button has moved a sufficient amount, the micro-switch contacts move into the pressure-induced position. Some pressure switches are designed so that their contacts remain open until closed by the action of fluid pressure against the switch position. Such switches are specified as NORMALLY OPEN (NO). Other switches are designed for their contacts to remain closed until opened by the reaction of fluid pressure against the switch piston. These are specified as NORMALLY CLOSED (NC).

(4) *Uses.* Pressure switches on Army aircraft serve two purposes. One is to close the circuit of a warning light that shows low pressure in a system. The other is to affect the circuits of solenoid valves in aircraft having dual hydraulic boost control systems in such a manner that operating pressure to one boost system cannot be shut off unless the other boost system is provided with enough operating pressure to fly the aircraft. Some pressure switches are designed with two sets of contacts so as to provide control for both the warning light and the solenoid valve.

(5) *Maintenance.* Maintenance of hydraulic pressure switches is limited to testing, removal, and replacement.

c. *Pressure Relief Valves.* Relief valves are safety devices used to prevent pressure from building up to a point where it might blow seals and thus burst or otherwise damage the container in which it is installed. Relief valves are installed in aircraft hydraulic systems to relieve excessive fluid pressure caused by thermal expansion, pressure surges, and the failure of a hydraulic pump compensator or other regulating devices.

(1) *System relief valves.* Main system relief valves are set to open and close at pressure determined by the system in which they are installed. In systems made to operate at 3,000-psi normal pressure, the relief valve might be set to be completely open at 3,650 psi and to reseal at 3,190 psi. These pressure ranges may be different from one aircraft to another. When the relief valve is in the open position, it sends excess pressurized fluid to the reservoir return line.

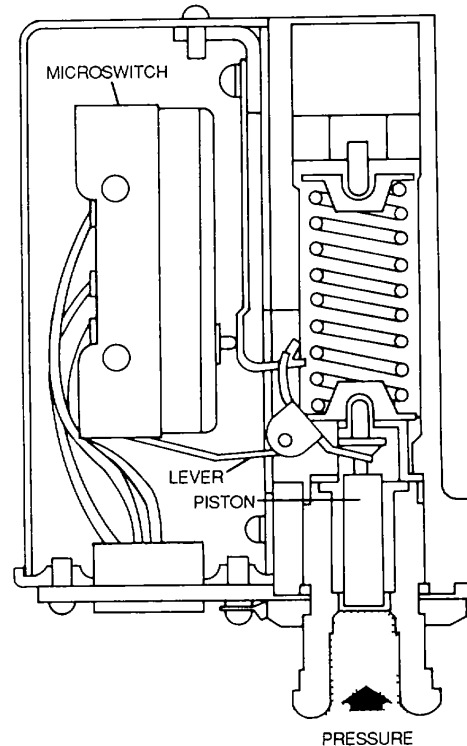
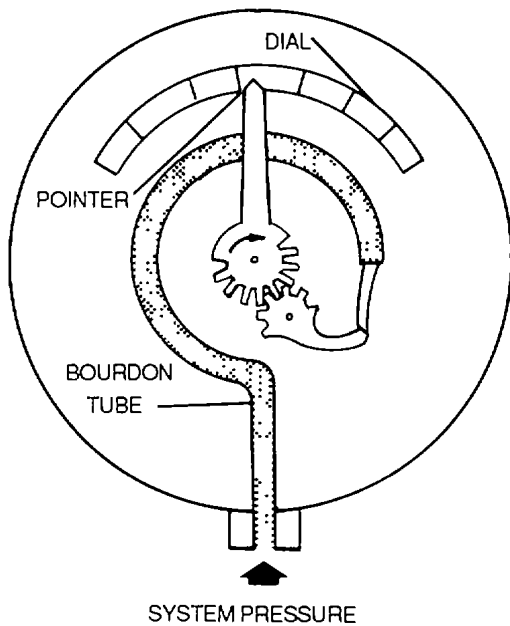
(a) *Description.* A typical main system relief valve and a breakdown of its component parts is shown in figure 4-116. The relief valve consists of a cylindrical housing containing a poppet valve and a piston assembly. Each end of the housing is made to include a wrench-holding surface and a threaded port for installation of a hydraulic fitting. The housing is stamped to denote the ports as PRESS (pressure) and RET (return). The poppet valve (1), which is located just inside the pressure port, is seated over a passage through the valve.

(b) *Operation.* When fluid pressure at the pressure port reaches 3,650 psi, the pressure forces the piston (2) to depress the load spring (3) and to move clear of the poppet valve. Thus, the passage through the piston is opened, and fluid flows through the valve into the return line. When pressure at the pressure port is reduced to 3,190 psi the coil spring reseats the piston against the poppet valve and fluid flow through the relief valve ceases. Should the pressure at the outlet port exceed the pressure at the inlet port, the poppet valve will unseat and fluid from the return line will flow through the valve into the pressure line.

(2) *Thermal relief valves.* Thermal relief valves are usually smaller than system relief valves. They are used in systems where a check valve or a selector valve prevents pressure from being relieved through the main system relief valve. As pressurized fluid in the line in which it is installed builds up to an excessive amount, the valve poppet is forced off its seat and the excess pressurized fluid flows through the relief valve to the reservoir. When system pressure decreases to a preset pressure, spring tension overcomes system pressure and forces the valve poppet to the closed position.

(3) *Maintenance.* Relief valve maintenance is limited to adjusting the valve for proper relief pressure and checking the valve for leakage. If it is thought that a relief valve is leaking internally a flexible hose may be connected to the return port of the valve and the drippings, if any, caught in a container. The opening and closing pressure of the valve may also be checked in this manner provided an external source of power is used.

d. *Pressure Reducing Valves.* Pressure reducing valves are used in hydraulic systems where it is necessary to lower the normal system operating pressure to a specified amount.



**Figure 4-114. Pressure Gauge**

**Figure 4-115. Piston-Type Pressure Switch**

(1) *Operation.* In figure 4-117, system pressure is being ported to a subsystem through the shuttle and sleeve assembly. Subsystem pressurized fluid works on the large flange area of the shuttle, causing the shuttle to move to the left after reaching a set pressure and thus closing off the normal system. The valve will stay in this position until subsystem pressure is lowered. The shuttle will then move to its prior position allowing the required amount of pressurized fluid to enter the subsystem.

(2) *Relief function.* During normal operation of the subsystem, the pressure reducing valve continuously meters fluid to the system. The pressure reducing valve is also designed to act as a relief valve. When pressurized fluid builds up to an excess amount within the subsystem, the shuttle assembly overcomes spring tension and moves farther to the left. This movement causes a passage to be opened to the return line, and all excess fluid is relieved. When pressure is lowered to an acceptable amount, the shuttle assembly returns to a balanced position.

**4-15. Accumulators.** An accumulator is used in a hydraulic system to store a volume of fluid under pressure. It acts as a cushion against pressure surges caused by pulsating fluid delivery from the pump or from system operation. The accumulator can supplement the pump output when the pump is under a peak load, and the stored energy in an accumulator can be used to actuate a unit in case the normal hydraulic system fails.

**WARNING**

Before removing valve core from a bleeder-type air valve assembly, ensure that all air has been exhausted by loosening air valve approximately one-fourth turn. Failure to comply may result in personnel injury as the valve may separate with explosive force. Eye protection must be worn.

a. *Types.* The two types of hydraulic accumulators used are the cylindrical type (see figure 4-118), using the floating pistons and seals, and the spherical type (see figure 4-119), using a diaphragm. Both types have a high pressure air valve installed for servicing the air side of the accumulator. A new high pressure valve core should be installed when the accumulator

air pressure has been exhausted through the valve core or the valve core has been removed from the air valve assembly. The hydraulic system pressure gauge will indicate the approximate accumulator air pressure when the hydraulic hand pump has been operated for a period of time starting with zero pressure on the hydraulic system.

b. Accumulator Operation. Spherical and cylindrical accumulators operate in essentially the same manner. In operation, the compressed-air chamber is charged to a pressure somewhat lower than the system operating pressure. This initial charge is referred to as the accumulator preload. When a preload is introduced in an accumulator, the hydraulic system pressure will be zero. As the system is subsequently pressurized and overcomes the preload pressure, the air will be compressed in the accumulator. When use of hydraulic units lowers system pressure, the compressed air will then force fluid from the accumulator into the system to satisfy system demands. Many aircraft have several accumulators in the hydraulic system. There may be an accumulator for the main and emergency systems, and there may be auxiliary accumulators located in venous unit systems.

c. Maintenance. Maintenance of accumulators at the organizational and Intermediate maintenance levels primarily consists of inspection and servicing. Some intermediate maintenance activities may have the responsibility for overhaul or repair, but this primarily rests with the depot maintenance units. Inspection and servicing procedures are as follows.

- (1) Visually inspect accumulators for indications of external hydraulic leaks.

**NOTE**

Use only dry air or nitrogen when pressurizing accumulator.

- (2) Test for internal leaks by momentarily depressing the valve core.

**NOTE**

- On cylindrical type accumulators, a slight amount of atomized hydraulic fluid is permissible. When liquid fluid escapes from the air valve, excessively worn seals or a scored piston are indicated and replacement of the accumulators necessary.
- On spherical type accumulators any indication of fluid at the air valve shall be cause for replacement of the accumulator, as this is an indication of deterioration or rupture of the diaphragm.

(3) Check the preload pressure on the accumulator by depleting the fluid pressure. This may be done by operating the controls of a system of which the accumulator is a part until all reserve pressure has been used.

- (4) Ensure that the air preload is completely exhausted before disassembling the accumulator.

**4-16. Flow Control Units.** Numerous valving devices are used in aircraft hydraulic systems to control the flow of fluid within the system. These devices perform such functions as controlling direction, sequence, and priority of flow; transforming fluid pressure into mechanical energy; holding loads in position against feedback-induced forces; and preventing leaks. The devices that perform these functions are selector valves, control valves, check valves, sequence valves, priority valves, shuttle valves, actuating cylinders, ratchet valves, servos, irreversible valves, and fuses.

a. Selector Valves. The purpose of a selector valve is to control the direction of movement of an actuating unit. It does this by providing pathways for pressure and return fluid into and out of an actuating unit, and by providing the means for immediately and conveniently switching the directions of the pressure and return fluid (necessary for reversing the direction of movement of the actuating unit). Selector valves are classified as closed-center and open-center types. These classifications are based on what happens to the flow of fluid when the selector valve is placed in the off position. When a closed-center selector valve is placed in the off position, its pressure passage is blocked to the flow of fluid and no fluid can pass through its pressure port. When an open-center selector valve is placed in



the off position, its pressure passage and return passage become interconnected and fluid can flow into the pressure port and out of the return port. Selector valves may be further classified on the basis of design characteristics as cam-operated, in-line radial, and compound.

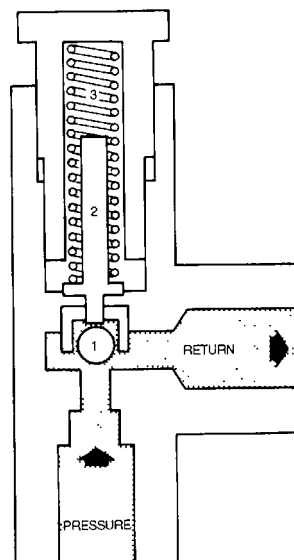
(1) *Closed-center selector valves.* The four closed-center type selector valves are the ones most commonly used in aircraft hydraulic systems. Rotor and spool type valving devices are used in these valves. The valves operate in one off position and in two on positions. Figure 4-120 shows a typical four-way, closed-center rotor-type selector valve. This valve is in the off position: all the valve ports are blocked, and no fluid can flow into or out of the valve.

(2) *Open-center selector valves.* Figure 4-121 illustrates an open-center, spool-type selector valve. This valve is in the off position, and as can be seen, the center seat provides an interconnection between the pressure port and the drilled passage in the spool. This permits fluid to enter the pressure port and pass freely through the valve and out of the return port.

(3) *Cam-operated selector valves.* Poppet type and ball-type selector valves are operated by cams that lift the poppet or ball off its seat. Purpose, use, and operation of the two types are the same one controls fluid flow by the use of poppets; the other employs a ball-shaped valve. The piston-type selector valve may also be cam-operated. In this case, flow is directed by the sliding action of a piston, which is a spool-shaped plunger within a housing.

(a) *In-line cam-operated selector valve (poppet-type).* The poppets of an in-line selector valve are similar to the pistons of an IN-LINE aircraft engine. In the neutral position, all four poppets are closed. With this type of valve, a pressure rise caused by an increase in temperature in either cylinder line can unseat an upper poppet. This will relieve the pressure into the return line. An Integral temperature relief valve, relieving from the pressure manifold into the return line is used in several models of the valve. Figure 4-122 shows a condition in which fluid pressure is forcing the actuating cylinder piston inward, permitting fluid to flow from the actuating cylinder through the lower unseated poppet to the return line. In figure 4-123, the selector valve control has been placed in the opposite direction. Fluid pressure is forcing the actuating cylinder piston outward, and fluid from the actuating cylinder flows through the other unseated poppet to the return line.

(b) *Radial cam-operated selector valve (poppet-type).* In the typical poppet-type radial selector valve shown in figure 4-124, the cam in the center is attached to a control handle. Moving the control handle causes the cam to rotate and moves the poppets on or off their seats. In the position shown here, poppets A and C are seated and poppets B and D are unseated. Fluid entering the inlet pressure port flows around poppet B and to the actuator unit through the cylinder 1 port. Fluid returning from the actuator unit enters through the cylinder 2 port, flows around poppet D, and exits through



- LEGEND**
- 1 POPPET VALVE
  - 2 PISTON
  - 3 LOAD SPRING

**Figure 4-116. System Relief Valve**

the return line. If the cam is rotated 90 degrees, poppets A and C will unseat and poppets B and D will seat. Fluid entering the inlet pressure port then passes around poppet A and to the actuator unit through the cylinder 2 port. Fluid returning from the actuator unit flows to the return line by entering the selector valve through the cylinder 1 port, flowing around poppet C, and exiting through the return port. If the cam is rotated 45 degrees from the position shown in the schematic, all poppets are seated and the selector valve is in a neutral position.

(4) *Compound selector valve.* To conserve space and make installation easy when banks of units are to be controlled, several selector valves are compounded into one unit. Each selector valve is controlled independently, but only one connection is needed for the pressure line and one for the return line.

b. *Control Valves.* For Army aircraft, the term control valve refers to a valve that controls direction of flow through alternate channels. Although similar in principle to a selector valve, a control valve functions more like a shutoff valve. Some control valves are actuated manually; others, electrically. Electrical actuation may be by means of either a solenoid or a motor. A solenoid-actuated valve is shown in figures 4-125 and 4-126. The

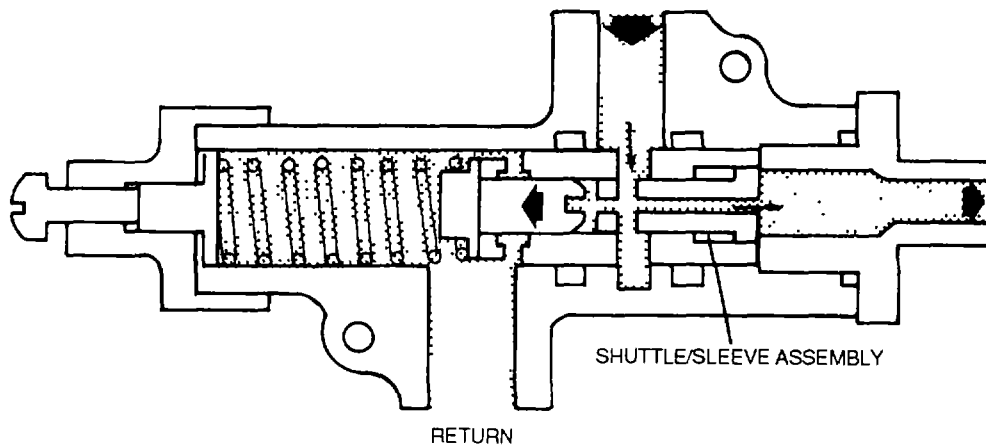


Figure 4-117. Pressure Reducing Valve

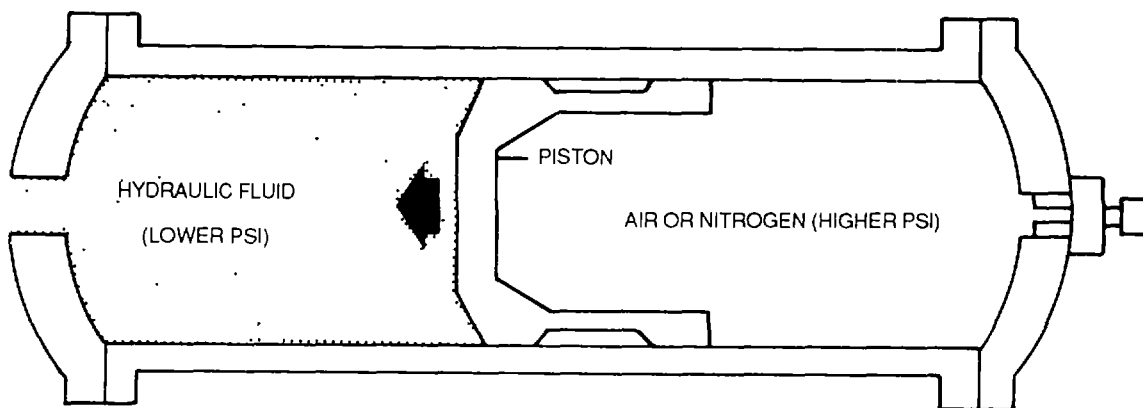
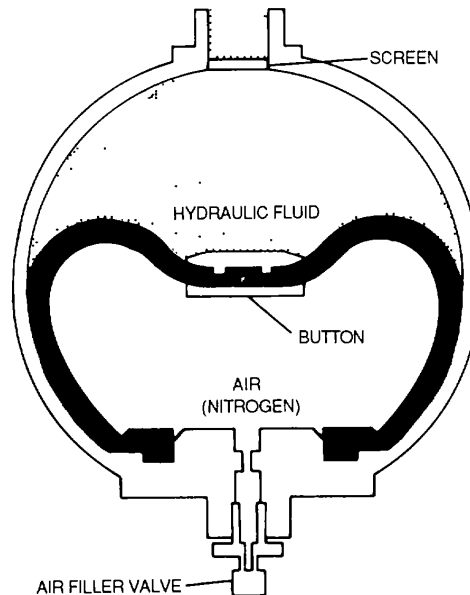


Figure 4-118. Cylindrical Accumulator

valve device is spring-loaded to one position and solenoid-actuated to the other position.

c. **Check Valves.** For hydraulic components and systems to operate as they should, the flow of fluid must be rigidly controlled. Fluid must be made to flow according to needs of the system. Many kinds of valve units are used for exercising such control. One of the simplest and most commonly used is the check valve. The check valve allows free flow of fluid in one direction, but no flow or a restricted flow in the other direction. There are two types of in-line check valves simple and orifice.

(1) **Simple-type.** Simple-type check valves shown in figure 4-127 are used when a free flow of fluid is desired in only one direction. Fluid entering the inlet port of the check valve forces the valving device off its seat against the spring. This permits fluid to flow through the passageway thus opened. The instant that fluid stops moving in this direction, the valving device is returned to its seat by the spring. This blocks the opening in the valve seat, thus blocking the flow of fluid through the valve.



**Figure 4-119. Spherical Accumulator**

(2) **Orifice-type.** The orifice-type check valve (sometimes called a damping valve) is used to allow normal operating speed of a mechanism by providing free flow of fluid in one direction, while allowing limited operation speed through restricted flow of fluid in the opposite direction. An orifice-type check valve is shown in figure 4-128. The operation of the orifice-type check valve is the same as that of the simple-type except for the restricted flow allowed when closed. This is accomplished by having a second opening in the valve seat. This second opening is never closed and is the means by which some reverse flow can take place through the valve. The second opening is much smaller than the opening in the valve seat. As a rule, this opening is a specified size in order to maintain close control over the rate at which fluid can flow through the valve in reverse.

(3) **Marking of valves.** The direction of fluid flow through in-line check valves is indicated by stamped arrow markings on the housing as shown in figures 4-127 and 4-128. On the simple-type in-line check valve, a single arrow shows the direction in which fluid can flow. The orifice-type in-line check valve is usually marked with two arrows. One arrow is more pronounced than the other, and indicates the direction of unrestricted flow. The other arrow is either smaller than the first or of broken-line construction and points in the direction of restricted reverse fluid flow.

d. **Sequence Valves.** The purpose of sequence valves (sometimes called timer check valves) is to set up a sequence of operation. In Army aircraft, these valves are used in such mechanisms as landing gear doors, landing gear uplocks and downlocks, cargo doors, ramps, and locks, and ejection seats to cause hydraulic operations to occur in a specific order. Two major types are used: mechanically-actuated and pressure-actuated.

(1) **Mechanically-actuated sequence valves.** The mechanically-actuated sequence valve is the type commonly used in Army aircraft. A typical valve of this type (shown in figure 4-127) consists of a housing in which there are two ports, a ball valving device, two springs, a plunger that extends through one end of the housing, and the necessary seals to prevent leakage. The input pressure line is connected as shown to the actuating cylinder and to sequence valve B. Since sequence valve B is now closed, fluid cannot pass through it. When the door is opened, the door actuating cylinder piston rod extends far enough to contact and depress the plunger of sequence valve B. This opens sequence valve B and allows fluid pressure to pass through to the

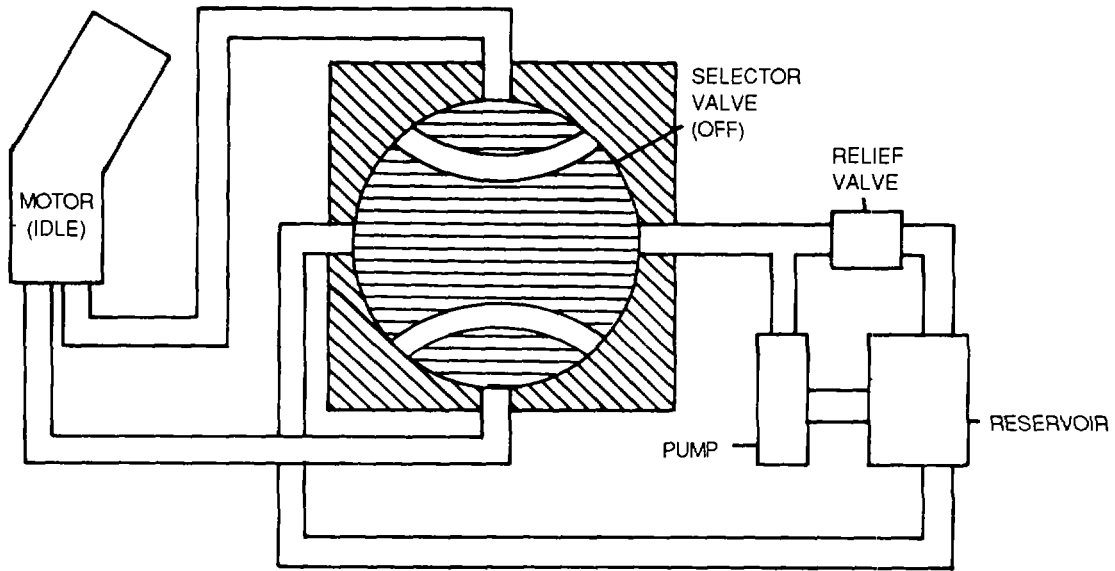


Figure 4-120. Rotary-Type, Closed Center Selector Valve

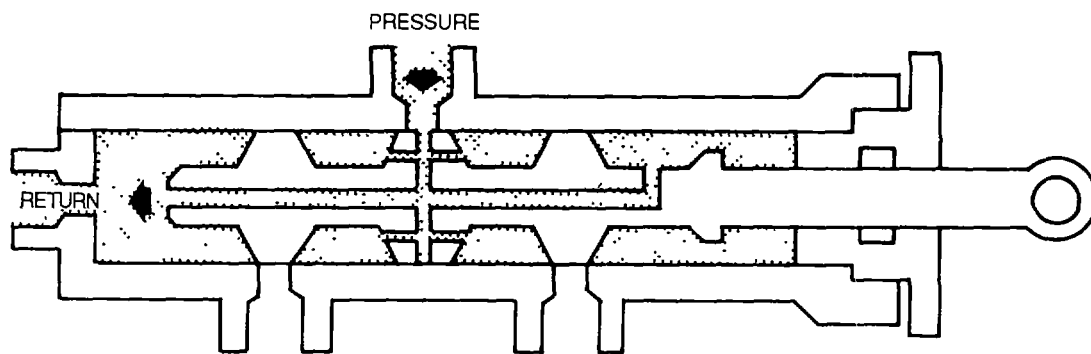


Figure 4-121. Spool-Type, Open Center Selector Valve (Closed)

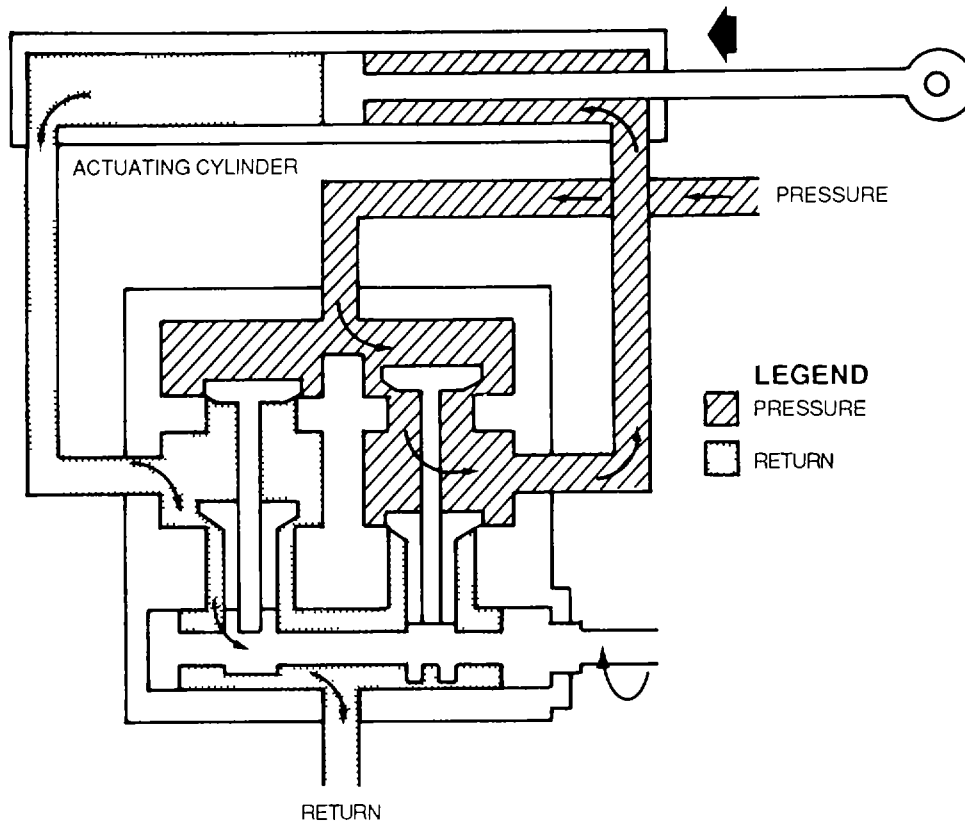


Figure 4-122. In-Line Cam-Operated Selector Valve (Actuator Retracting)

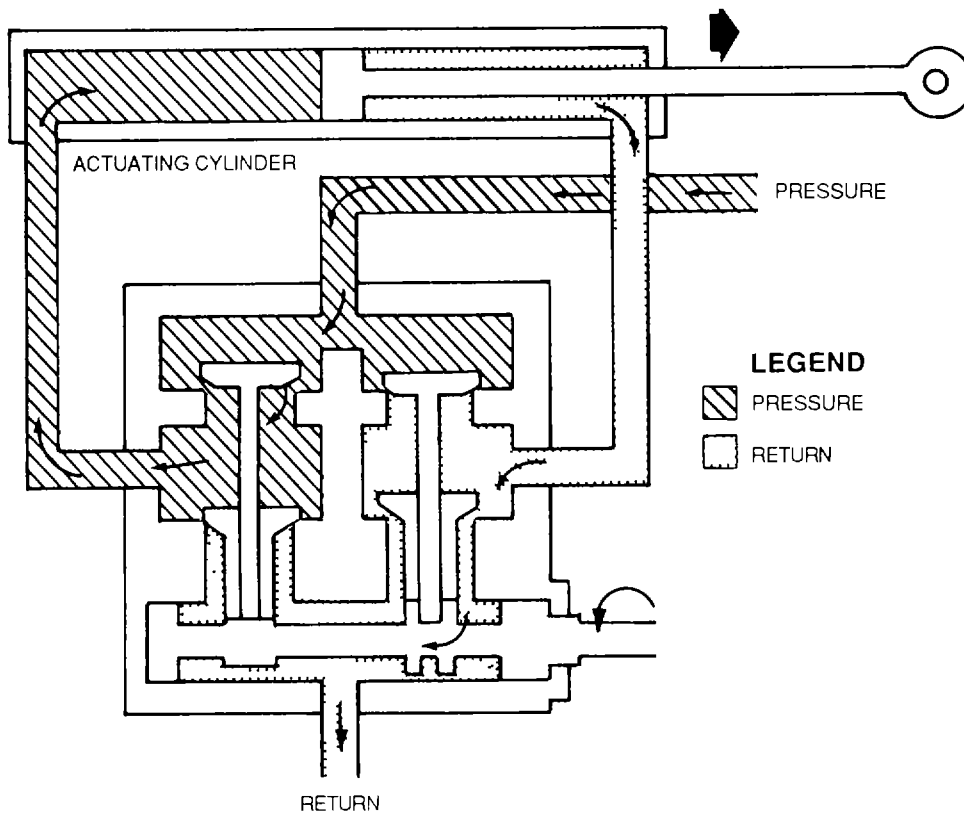
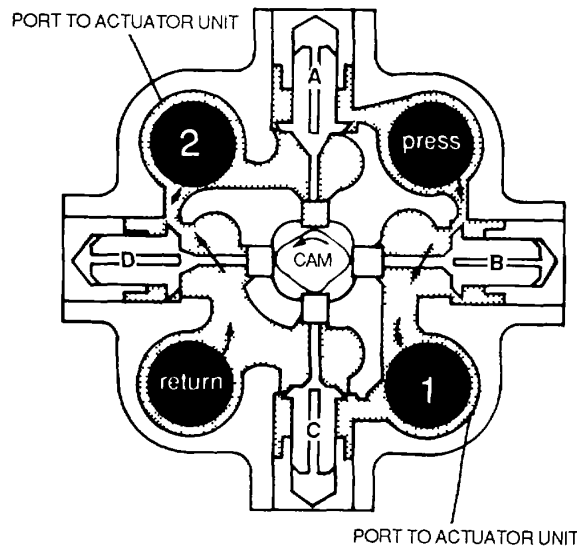


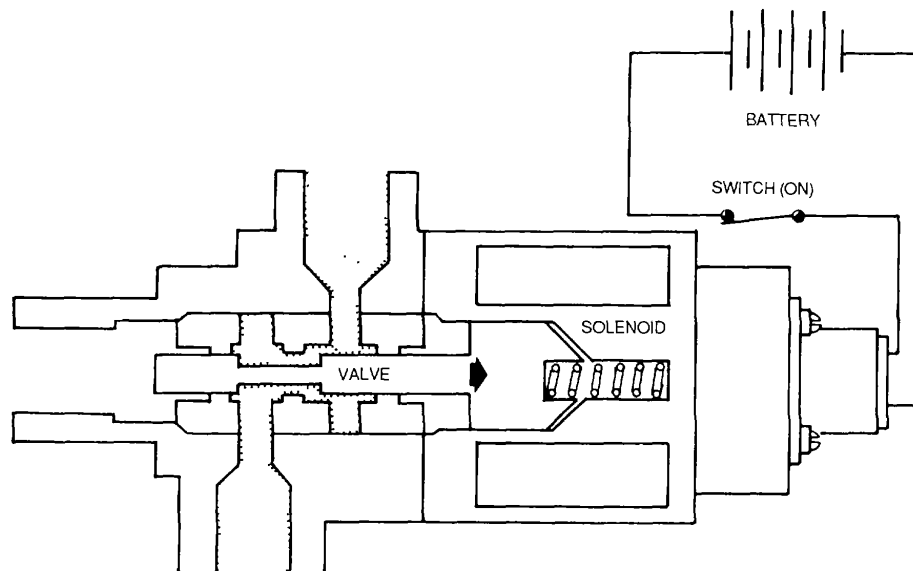
Figure 4-123. In-Line Cam-Operated Selector Valve (Actuator Extending)



**Figure 4-124. Radial Cam-Operated Selector Valve**

down side of the landing gear actuating cylinder, thus extending the gear. Return fluid from the door actuating cylinder is routed to the reservoir through sequence valve. A while the landing gear is still retracted and the sequence valve is still open.

(2) *Pressure-actuated sequence valves.* The typical pressure-actuated sequence valve consists of a three-port housing, a spool-type valving device, and an adjustable spring. Operation of the pressure-actuated sequence valve shown in figure 4-130 is dependent upon movement of the spring-loaded spool. Unlike the mechanically-operated type, no mechanical contact with any other unit is necessary to operate a pressure actuated sequence valve. When the selector valve is positioned, fluid pressure is directed to the pressure inlet port of the sequence valve and passes through the valve to the first unit to be actuated. The pressure necessary to operate this unit is less than that required to move the spool against the restraint of its spring. After operation of the first unit is completed and flow to it ceases, pressure in the passage between the pressure inlet port and the first unit port increases. This pressure is conducted through a special passage to the underside of the pilot piston on the lower end of the spool, forcing the spool upward until the passage between the pressure inlet port and the port to the second unit becomes unblocked. Fluid then flows into the second unit, causing it to operate.



**Figure 4-125. Solenoid-Actuated Control Valve (Energized)**

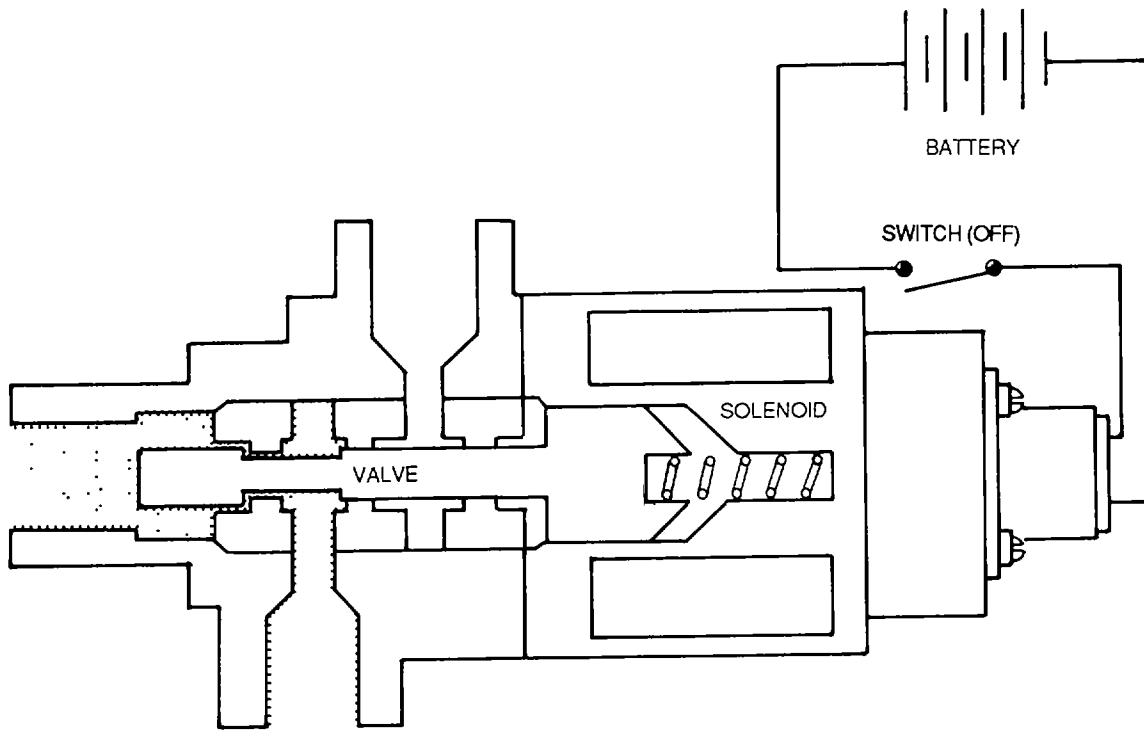


Figure 4-126. Solenoid-Actuated Control Valve (De-energized)

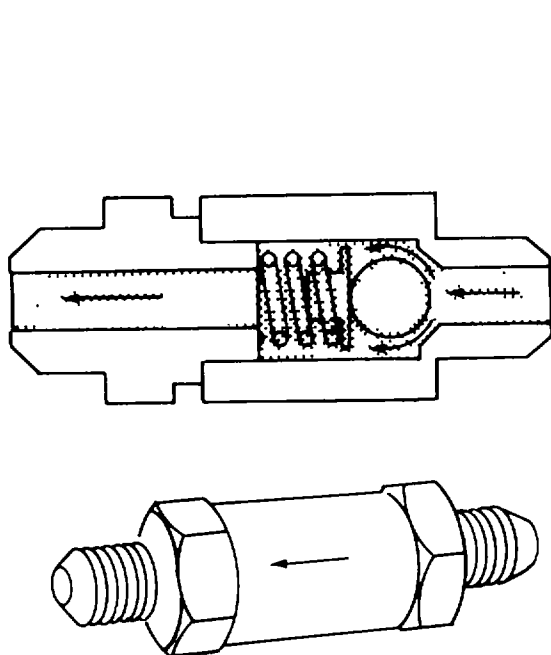


Figure 4-127. Simple Check Valve

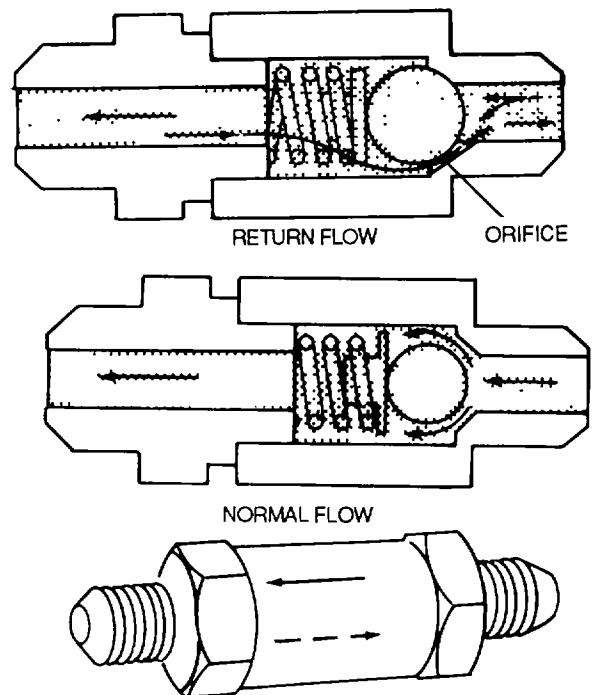
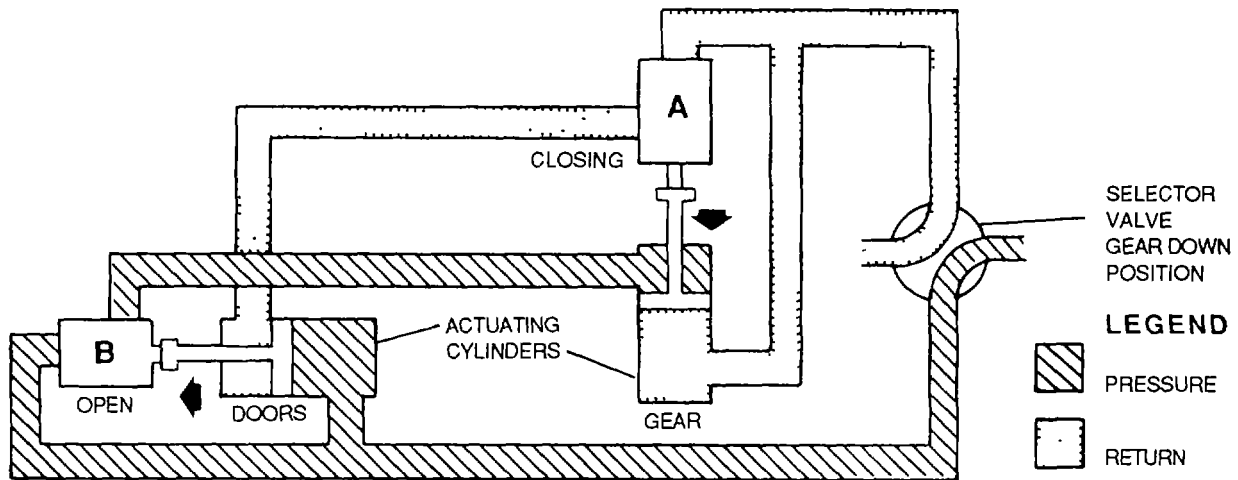


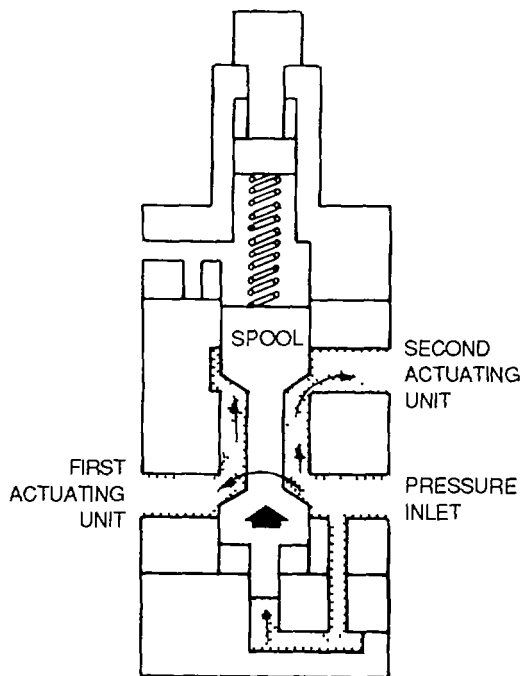
Figure 4-128. Orifice Check Valve



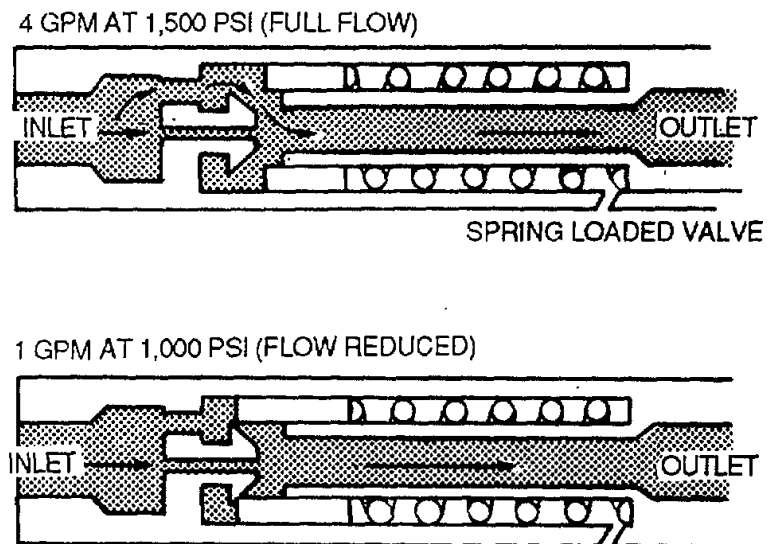
**Figure 4-129. Landing Gear System Using Mechanically Actuated Sequence Valves**

e. Priority Valves. Priority valves are installed in hydraulic systems to provide adequate fluid flow to units requiring immediate completion of action. Figure 4-131 illustrates the operation of a priority valve. The priority valve is installed in the line between an actuating unit in which completion of action can be delayed and its source of operating pressure. As long as system pressure is normal, the flow of fluid to the delayable unit is unrestrained. When system pressure drops below normal, the priority valve automatically reduces the rate of flow to the unit not requiring immediate completion of action. Priority valves are used in hydraulic systems to give operating priority to such units as brakes, landing gear, and flaps.

f. Shuttle Valves. In some cases, two sources of operating pressure are connected to a single component or system. One of the pressure sources will be reserved for emergency use. Provisions are usually



**Figure 4-130. Pressure-Actuated Sequence Valve**

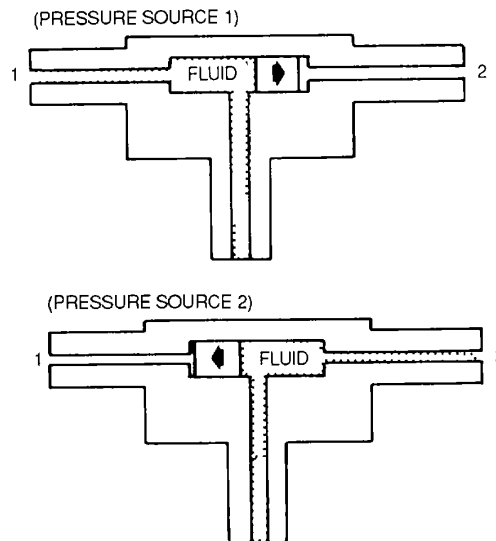


**Figure 4-131. Priority Valve**



made in such cases to eliminate any possible transfer of fluid from one pressure source to the other. This is done by means of shuttle valves. Army aircraft equipped with dual brake systems use shuttle valves to isolate the pilot and copilot master cylinders from each other so as to allow optional operation of the brakes by either set of master cylinders. Also, Army aircraft having compressed-air equipment for emergency operation of landing gears and wheel brakes use shuttle valves to isolate the system hydraulic fluid from the compressed air or other authorized gas used in emergency operation. Two types of shuttle valves are used in Army aircraft the floating-piston type, and the detent-type.

(1) *Floating-piston type.* In the floating-piston type shown in figure 4-132, fluid entering the shuttle valve from pressure source 1 moves the piston to block the flow from pressure source 2 so that fluid flows to the unit being actuated from pressure source 1 only. Conversely, fluid entering from source 2 would reposition the piston to block the flow from source 1; fluid would then flow to the unit being actuated from pressure source 2 only. The piston is restrained against random movement by the slight drag of the O-ring against the cylinder walls.



**Figure 4-132. Floating-Piston Shuttle Valve**

(2) *Detent-type.* The detent-type shuttle valve operates on the same general principles as the floating-stop type, with the exception that a spring-loaded detent ball holds the piston in the position dictated by the pressure source

*g. Actuating Cylinders (Actuators).* Actuating cylinders transform energy in the form of fluid pressure into mechanical force so that the energy can perform work. They impart powered linear motion to some movable object or mechanism. A typical actuating cylinder is made of a cylinder housing, one or more pistons and piston rods, and the necessary seals to prevent leakage between the piston rods and the end of the cylinder. The cylinder housing contains a polished bore in which the piston operates and one or more ports through which fluid enters and leaves the bore. Actuating cylinders come in two major types single-action and double-action.

(1) *Single-action.* The single-action (single port) actuating cylinder causes movement in one direction only. Operation of this type of cylinder controlled by a three-way control valve. In this single-action cylinder shown in figure 4-133, fluid under pressure enters the port at the left and pushes against the face of the piston, forcing the piston to the right. As the piston moves, it is forced out of the spring chamber through the vent and the spring is compressed. When pressure on the fluid is released to a point less than the force in the compressed spring, the spring pushes the piston toward the left. As the piston moves to the left, fluid is forced out of the fluid port and air enters the spring chamber through the vent.

(2) *Double-action.* The double-action (two-port) actuating cylinder causes movement in two directions. Operation of this type of cylinder is usually controlled by a four-way selector valve. Placing the selector valve in the on position (see figure 4-134), admits fluid pressure to the left-hand chamber of the actuating cylinder, thus forcing the piston to the right. As the piston moves to the right, it pushes return fluid out of the right-hand chamber and through the selector valve to the reservoir. When the selector valve is placed in its other on position (see figure 4-135), fluid pressure enters the right-hand chamber and forces the piston to the left. As the piston moves to the left, it pushes return fluid out of the left-hand chamber and through the selector valve to the reservoir. Besides having the ability to move a load into position, a double-action cylinder can hold a load in position in opposition to any force which may tend to displace it. This capability exists because, when the selector valve used to control operation

of the actuating cylinder is placed in the off position, fluid is trapped in the chambers on both sides of the actuating cylinder piston. This locks it against movement in either direction.

(3) *Allowable leakage.* The seepage of some fluid past shaft end seals and bearings is necessary for their lubrication. However, through normal wear, seepage develops into leakage. Moderate leakage at piston rod end bearings and seals during operation is normal in actuating cylinders which have been in use for some time. There are established limits as to the amount of leakage permitted at such points. The general military specification for allowable external leakage at each shaft seal and bearing is one drop per 25 cycles of operation (25 full or partial strokes in each direction). This specification is applicable except where a different leakage limitation is specifically stated in publications for the equipment concerned.

(4) *Maintenance.* Care of hydraulic actuating cylinders shall be as specified in applicable aircraft maintenance manual. Typical troubleshooting data is outlined in table 4-40.

(a) To reduce excessive wear and possible failure of hydraulic cylinder packing rings, exposed part of piston rod shall be cleaned as follows:

1 Remove foreign materials by wiping with a clean cloth saturated with hydraulic fluid, MIL-H-5606 or MIL-H-83282.

2 If extreme foreign materials are encountered, clean before and after each flight.

3 If operating in freezing temperature, cleaning is accomplished easier immediately after landing.

(b) Replace hydraulic cylinders when the rod becomes scratched, nicked, or dented deep enough to cause leakage.

(c) When overhauling hydraulic cylinders, all ferrous metal parts will be magnetic particle-inspected for cracks and flaws. Inspection will be accomplished in accordance with TM 55-1500-335-23, and TM 551500-204-23-7 Parts will be marked properly after inspection.

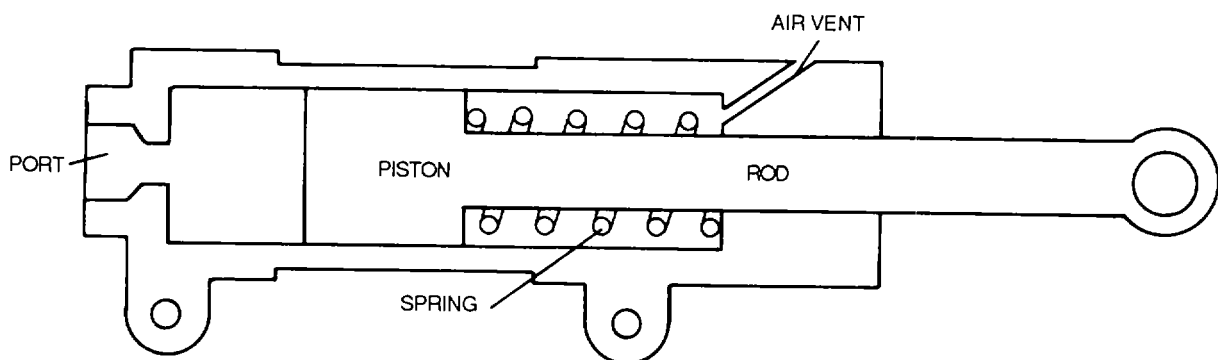


Figure 4-133. Single-Action Actuating Cylinder

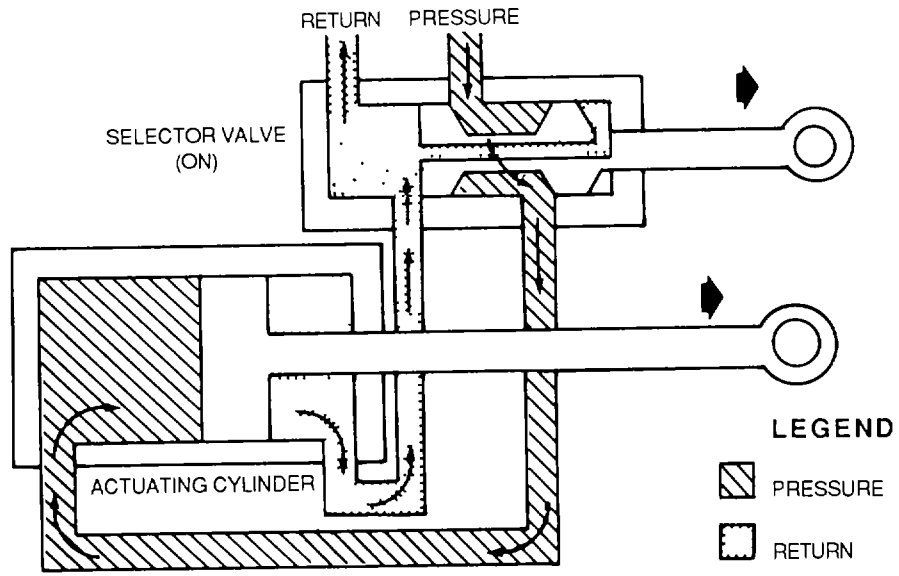


Figure 4-134. Double-Action Actuating Cylinder (Extension)

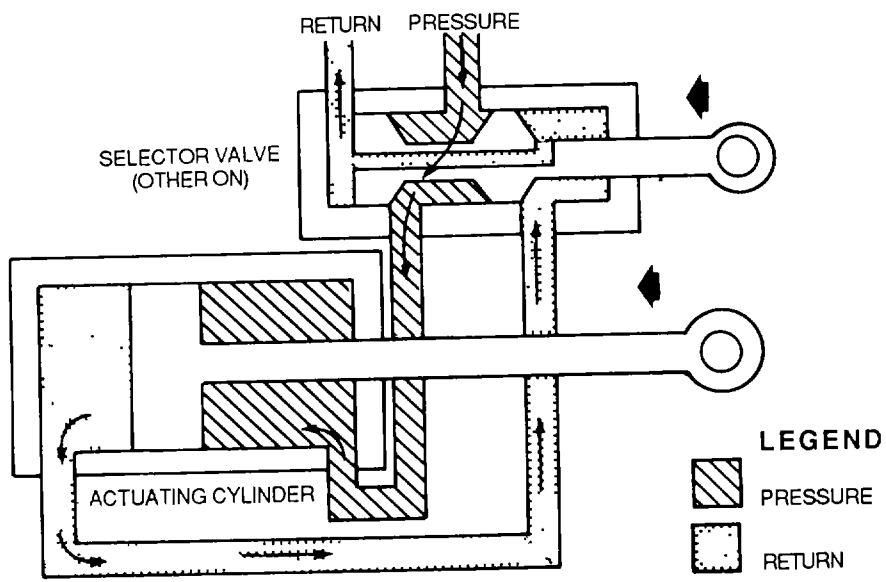


Figure 4-135. Double-Action Actuating Cylinder (Retraction)

**Table 4-40. Troubleshooting Actuators**

Trouble	Probable Cause	Remedy
Leakage from operating end of piston	Packing around piston rod is leaking	Disassemble cylinder and replace packing, if worn
External leakage around head and base	Lockring holding gasket is not right	Tighten
	Gasket is worn	Replace with new gasket
Leakage from one side of piston to the other	Packing on piston is worn or scored	Disassemble and replace packing
	Packing Inside piston is worn or scored	Disassemble and replace packing
	Piston is not securely fastened to piston rod	Tighten nut holding piston on piston rod
	Smooth finish on barrel is scratched or scored	Overhaul

*h. Ratchet Valve.* Hydraulic ratchet valves are used as companion devices to double-action actuating cylinders. The purpose of a ratchet valve is to aid an actuating cylinder in holding a load in the position into which it has been moved by operation of a hand pump. The ratchet valve insures that there will be trapped fluid on each side of the actuating cylinder piston. This is necessary for the actuating cylinder to lock a load against movement in either direction, and is especially vital should the selector valve which controls the actuating cylinder be left in the on piston or have Internal leakage. The ratchet valve does not affect actuating cylinder piston movements that are intentionally produced by means of system operating pressure. Ratchet valves are optional equipment and are used only in cases where locking a load in position is of great importance. In figure 4-136, the ratchet valve is shown with no pressure applied (selector valve off ). The piston is centered in its bore, and both check valves (balls A and B) are closed. This locks the actuating cylinder in position by trapping all fluid in the cylinder. The ratchet valve is shown in figure 4-137 with pressure applied to port 1. This forces the piston to the right where it unseats ball check B. Pressure entering port 1 unseats ball check A on the left side. Fluid then flows through the ratchet valve, and the piston moves to the right, unseating ball check B.

*i. Hydraulic Servos.* Many situations exist in which powered movements must be consistently made with accuracy within thousandths of an inch; such exact control cannot be effected by an actuating cylinder merely connected with a selector valve. Hydraulic servos perform this function. Hydraulic servos are used in both airplanes and helicopters to multiply the physical effort expended by personnel in operating the aircraft. Servos enable a pilot to use fingertip force in controlling the actions of a flight control system that may actually require hundreds of pounds of force to actuate.

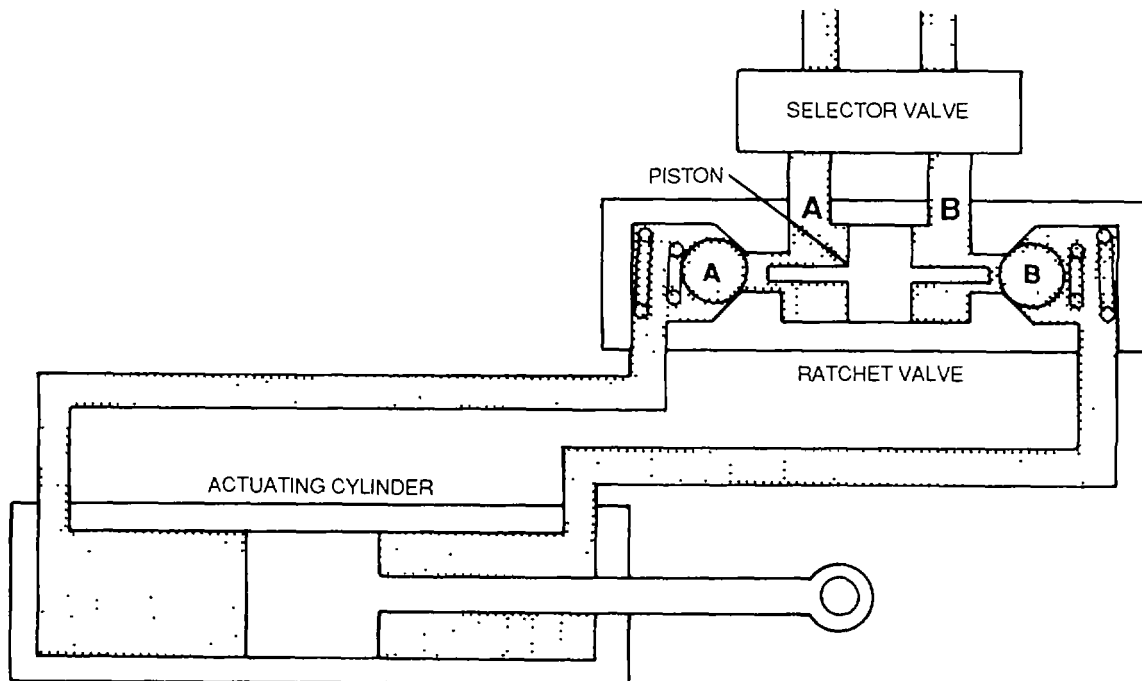
(1) *Design.* In effect, a hydraulic servo is a combination of an actuating cylinder and a selector valve in a single unit. The servo selector valve is manually opened by the operator and is automatically closed by the servo's movement. The spool-shaped valving device of the servo selector valve is commonly referred to as a pilot valve. Servos are made in two general designs. In one design, the servo cylinder housing is stationary and the piston rod moves. In the other design, the piston rod is stationary and the cylinder housing moves. For convenience, a servo in which the

cylinder housing is stationary and the piston moves is used for the following explanation of basic servo operation and of servo sloppy finks and bypass valves. Such a servo is shown in figure 4-138.

(2) *Operation.* To exemplify servo operation, let us assume that the servo pilot valve has been moved a given distance to the right from the off position and is to be held there. If the given distance is 0.250 Inch, the following will result:

- Fluid under pressure will flow through the now unblocked selector valve cylinder port and will enter the left chamber of the servo cylinder housing.
- The piston will be forced to the right and will carry the selector valve housing with it since that housing is welded to the piston rod.
- When the piston has moved to the right exactly 0.250 inch, the selector valve housing will have moved to the right over the now stationary pilot valve. This will result in returning the selector valve to the off position. Since the flow of fluid is now stopped, the piston will travel no farther.

j. *Irreversible Valves.* Irreversible valves assist hydraulic servos in a manner similar to that in which ratchet valves assist actuating cylinders. Both ratchet valves and irreversible valves provide defense against movement of the unit by an externally applied force. Irreversible valves are used with hydraulic servos in a helicopter flight control system to block the travel of feedback forced from their point of organ in the rotor head and blades to the control stick figure 4-139 illustrates basic operation of the Irreversible valve. The check valve in this mechanism allows fluid from the pump to flow in the normal direction as shown by the arrows. However, feedback force tends to move the servo piston in the opposite direction to the pump produced pressure. This tends to force fluid backward through the irreversible valve. The check valve blocks this rearward flow of fluid and keeps the servo piston from yielding to feedback force. The relief valve serves as a safety device to limit the pressure produced by feedback-induced movement of the servo piston. It opens to allow fluid to bypass to the return line if the feedback-produced pressure exceeds a preset safe limit.



**Figure 4-136. Ratchet Valve (Static)**

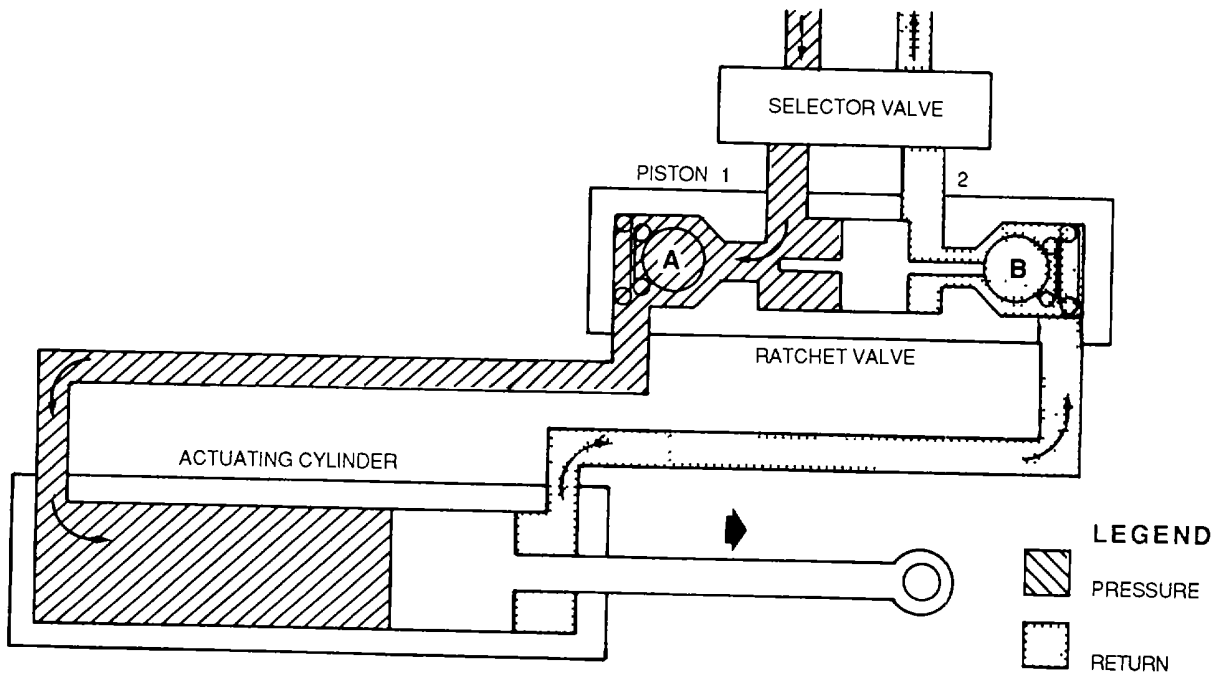


Figure 4-137. Ratchet Valve (Moving)

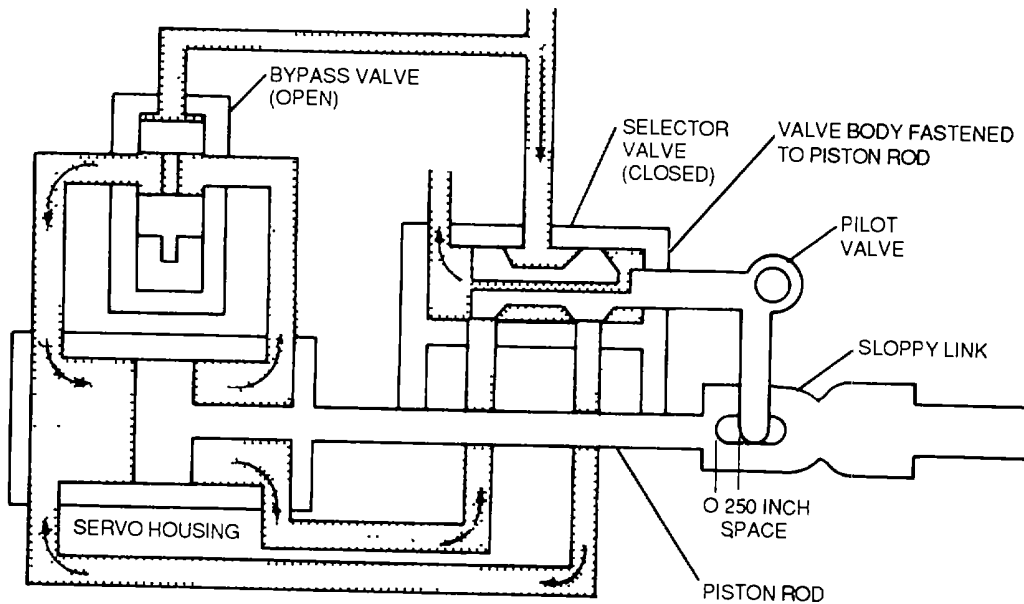
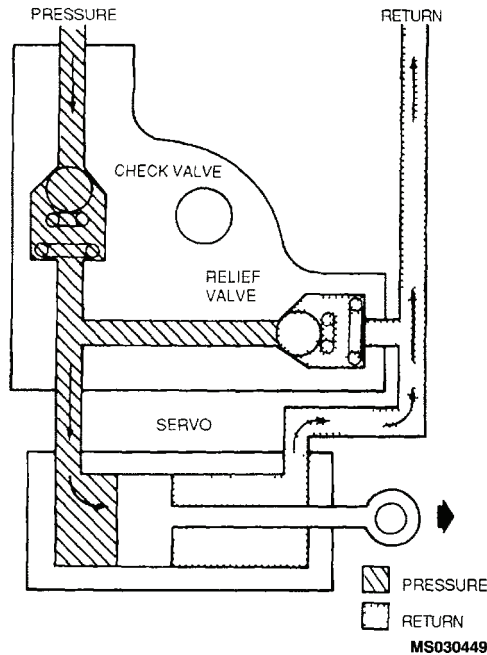
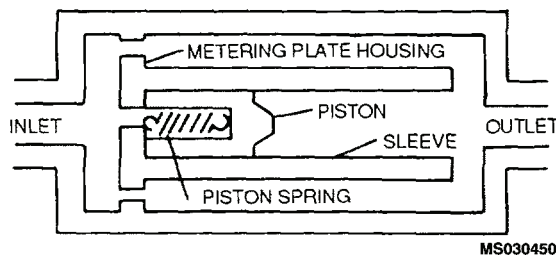


Figure 4-138. Hydraulic Servo



**Figure 4-139. Irreversible Valve**

**k. Hydraulic Fuses.** Fuses are incorporated in hydraulic systems to prevent continued loss of fluid in cases of serious leakage. Fuses are strictly safety devices. They are not needed for operation of the system. Hydraulic fuses are usually installed in lines that are run in hazardous locations or that conduct fluid to components located in such places. They can only be used in lines through which fluid flows in one direction but not continuously or in lines through which flow is reversed at intervals. A hydraulic fuse is designed to permit only a limited quantity of fluid to pass through it. When this limit is reached, the fuse automatically shuts off further flow. The typical fuse shown in figure 4-140 consists essentially of a housing, a sleeve, a piston, a piston return spring, and a metering plate. The housing has a port at each end; one pressure, the other, return. The sleeve is attached to the housing and is centered on the axis of the housing. It has a polished bore in which the piston operates. Holes in the end of the sleeve nearest the outlet port open the bore of the sleeve to a space between the sleeve and the housing. The metering plate divides whatever fluid enters the fuse into streams of unequal size. The larger streams flow around the outside of the sleeve; the smaller streams, through the inside.



**Figure 4-140. Hydraulic Fuse Assembly**

**(1) Normal flow.** Whenever the fuse is not transmitting fluid, its piston is pulled to the inlet end of the fuse by the piston return spring as shown in figure 4-141. As soon as fluid begins flowing through the fuse, the stream of fluid that enters the sleeve reacts against the piston. This causes a slow movement of the piston toward the outlet end of the sleeve. Meanwhile, the stream of fluid that flows on the outside of the sleeve passes through the communication holes in the sleeve and then out of the fuse outlet port. As long as the quantity of fluid passing through the fuse is equal to or less than the rated flow capacity of the fuse, the piston travels less distance within the sleeve than its travel limit.

TM 1-1500-204-23-2

(2) **Blocked flow.** If the flow of fluid through the fuse becomes greater than its rated flow capacity, the increased pressure causes the piston to travel until the needle on its end plugs the opening at the outlet end of the housing, thus blocking further fluid flow through the fuse (see figure 4-142). The piston is held in the blocking position until the pressure is relieved. When the pressure is relieved, the piston return spring retracts the piston and fluid again flows through the fuse.

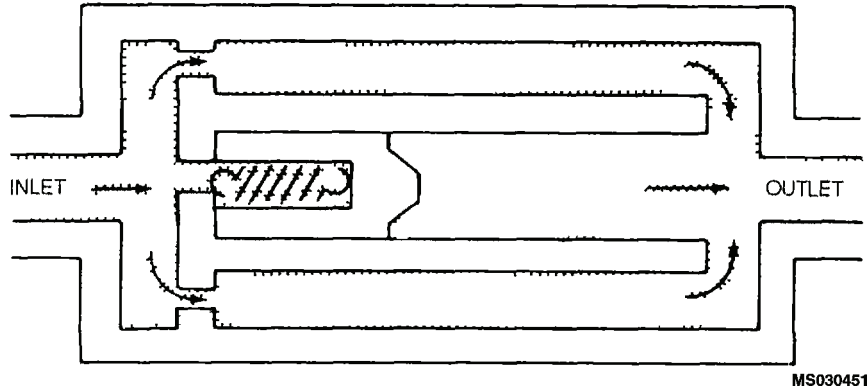


Figure 4-141. Hydraulic Fuse (Full Flow)

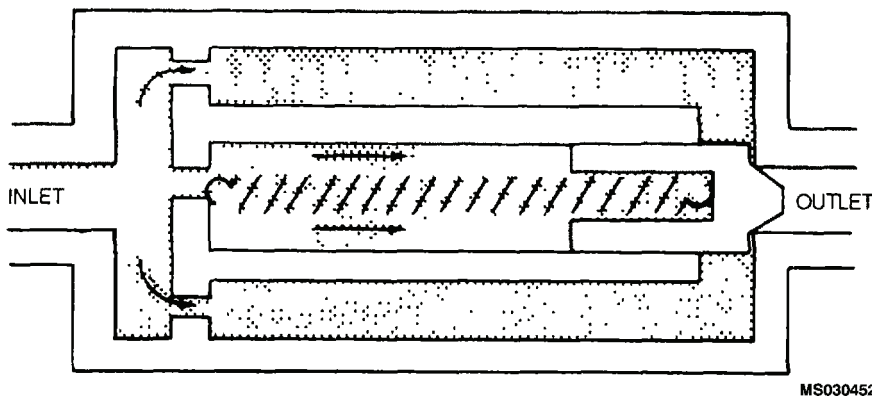


Figure 4-142. Hydraulic Fuse (Blocked Flow)

**WARNING**

Degreasing solvent, MIL-PRF-680, is combustible and toxic to eyes, skin and respiratory tract. Wear protective gloves and goggles/face shield. Avoid repeated or prolonged contact. Use only in well ventilated areas (or use approved respirator as determined by local safety industrial hygiene personnel). Keep away from open flame other sources of ignition.

**I. Maintenance of Hydraulic Flow Control Units.** Extreme cleanliness is essential. Small particles of foreign matter lodged in assemblies will cause leakage or improper operation of the valve. Wash all parts, except solenoids, with degreasing solvent, MIL-PRF-680, and dry with compressed air.

**4-17. TYPES OF PNEUDRAULIC SYSTEMS.** The arrangement of components within the hydraulic systems varies among the different types of aircraft. However, all aircraft hydraulic systems incorporate the components described in paragraph 4-16 . The hydraulic system may be an open-center or a closed-center type and may be interconnected with a pneumatic system that serves as an emergency pressure source in case the main system fails.



**a. Open-Center Hydraulic System.** An open-center hydraulic system has hydraulic fluid flow but no pressure until some actuating unit is operated. A typical basic open-center system such as the one shown in figure 4-143 consists primarily of a reservoir, a constant-delivery type pump, a relief valve, one or more selector valves, and one or more actuating units. This system does not require a pressure regulator. The system relief valve limits system pressure when the selector valve is in an on position and an actuating unit is operating.

**(1) Operation of system with selector valves in off position.** Fluid flows from the reservoir into the pump and from the pump into the main pressure line. Because all selector valves are in the off position, the fluid passes back to the reservoir through the open-center passage of these valves. Since no restrictions exist in the system, there is no pressure in the system other than that caused by friction.

**(2) Operation of system with one selector valve in on position.** With one selector valve in the operating position, as shown in figure 4-144, fluid flows under pressure to the actuating unit. As the actuating unit moves, it forces residual fluid from the piston through the open selector valve and back to the reservoir. At the end of the stroke of the actuating unit, fluid flow becomes blocked and pressure increases within the system. Eventually, the pressure builds up to the setting of the relief valve, at which point it is bypassed to the return line and back to the reservoir. This condition exists until the selector valve is returned to the neutral (off) position.



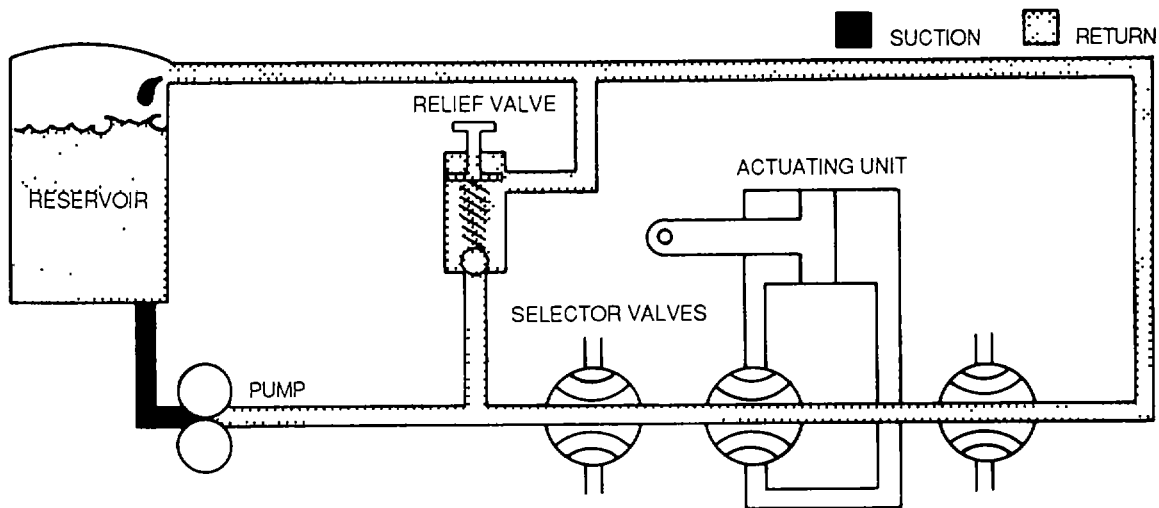


Figure 4-143. Open-Center Hydraulic System (Valve Closed)

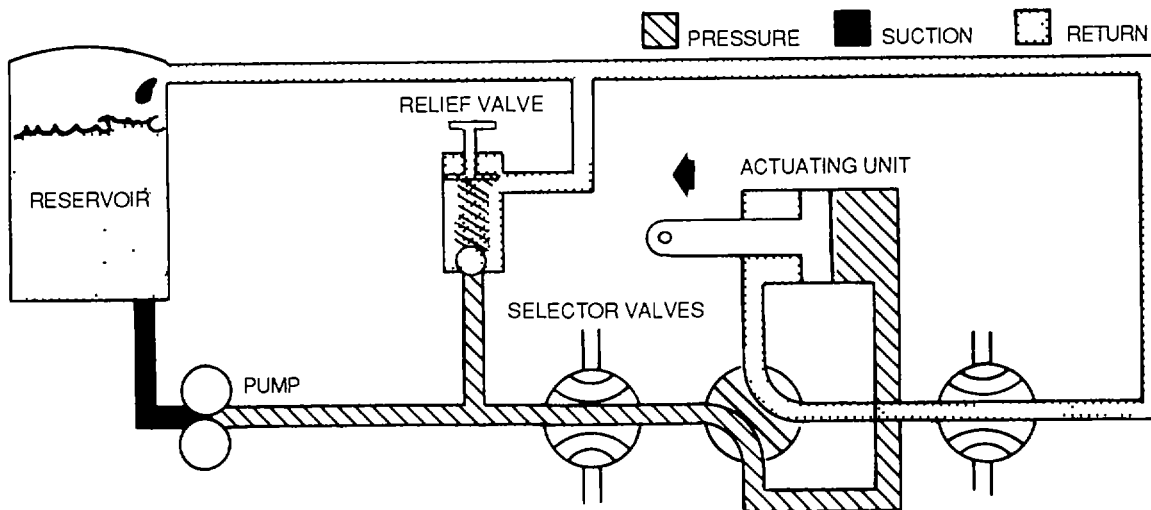


Figure 4-144. Open Center Hydraulic System (Valve Open)

b. Closed-Center Hydraulic System. A closed hydraulic system is sometimes called a direct system because the hydraulic fluid is under pressure throughout the system when the pump is operating. A basic closed-center hydraulic system consists primarily of a reservoir, a pump, a relief valve, one or more selector valves, and one or more actuating units. In figures 4-145 through 4-147, each of the three selector valves controls a different actuating unit and each valve is in a different position. Hydraulic fluid is drawn from the reservoir to the pump, which forces the fluid on to the selector valves A, B, and C with results as described in the following paragraphs.

(1) Selector valve A. In figure 4-145, the rotor of selector valve A is positioned so that the valve ports are closed. The hydraulic fluid is trapped in the lines leading from the selector valve to each side of the piston in the actuating unit. Thus, the fluid cannot move in any direction. This holds the piston in a locked position, and any attached mechanism will be held in a fixed position.

(2) Selector valve B. In figure 4-146, the rotor of selector valve B is positioned so as to direct the fluid flow from the selector valve to the face of the piston in the actuating unit. This pressure forces the piston to move outward, causing any mechanism attached to the piston rod to function. Fluid moving out of the actuating unit as the piston moves outward flows into the return line to the reservoir.

(3) Selector valve C. In figure 4-147, the rotor of selector valve C is positioned to direct the fluid flow to the rod side of the piston, forcing the piston to move

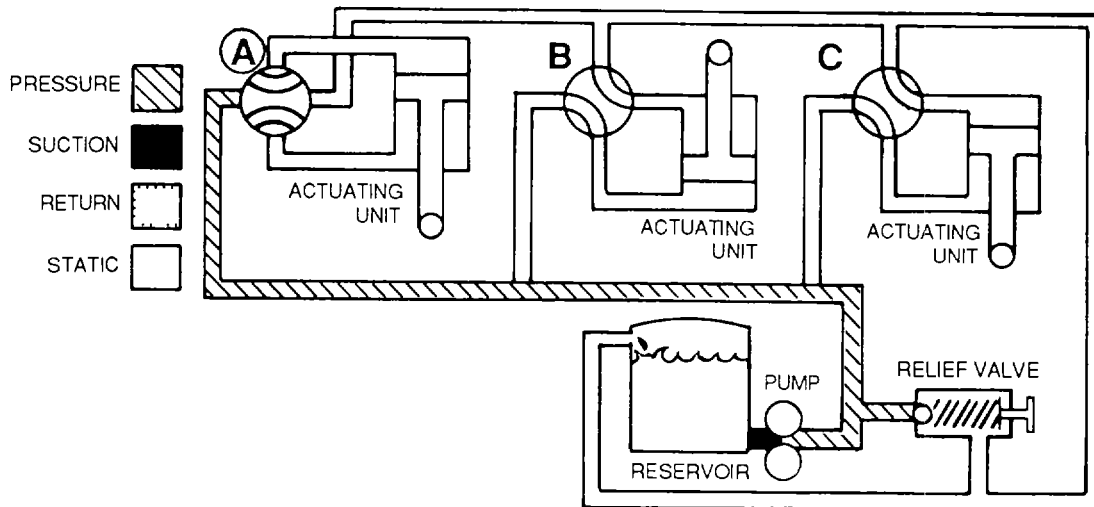


Figure 4-145. Selector Valve A Closed

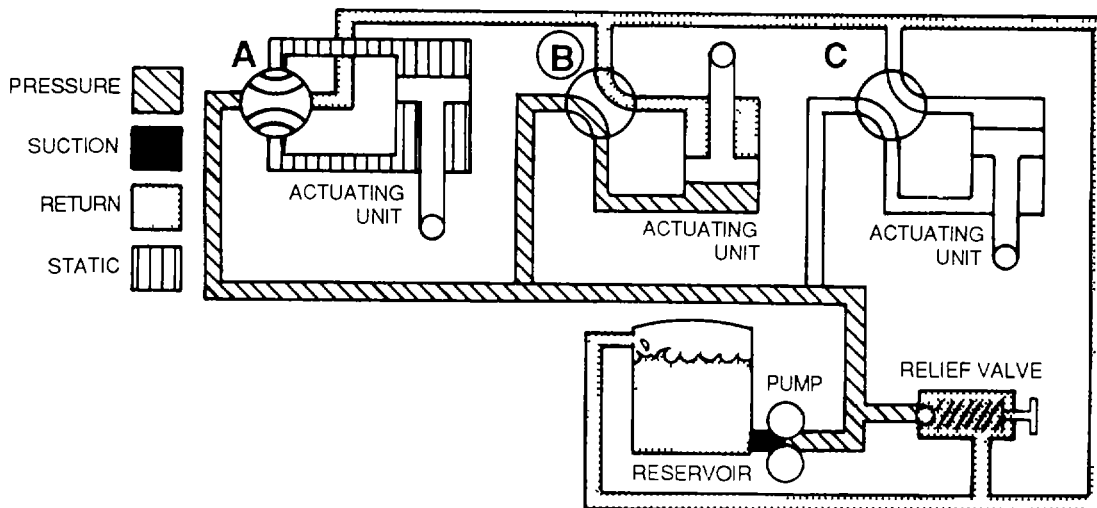


Figure 4-146. Selector Valve B Open

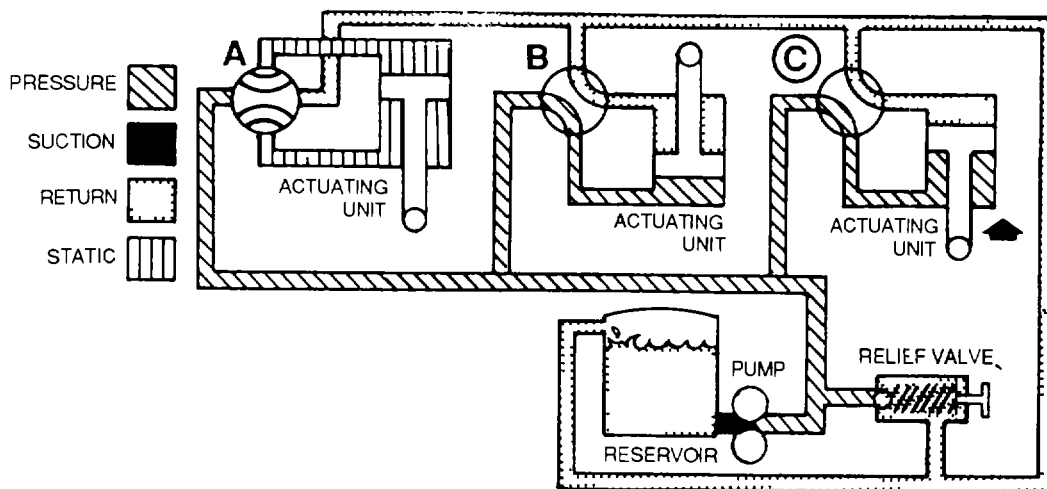


Figure 4-147. Selector Valve C Open

inward. Fluid moving of the actuating unit as the piston moves Inward flows into the return line to the reservoir.

c. *Pneumatic System.* Aircraft pneumatic systems are mostly used as an emergency source of pressure for hydraulically operated subsystems. The pneumatic power system usually consists of one or more high pressure air cylinders, pressure gauges, and pressure warning lights. Since the pneumatic power source does not replenish itself during flight, the compressed supply is good for only a certain number of operations.

(1) *Construction.* High pressure pneumatic systems are constructed to operate in much the same manner as hydraulic systems. A shuttle valve connects the pneumatic system to the hydraulic system. This allows the use of the same tubing and units for both systems. The shuttle valve separates the normal hydraulic system from the pneumatic system. Pneumatic system selector valves control the air to the subsystems. Each subsystem is connected to the high pressure air source through a pressure regulator and relief valve assembly and a selector valve. Since pneumatic selector valves are installed in parallel, air pressure is immediately available to all subsystems for instant operation. Connected in this manner, more than one system can be operated at the same time.

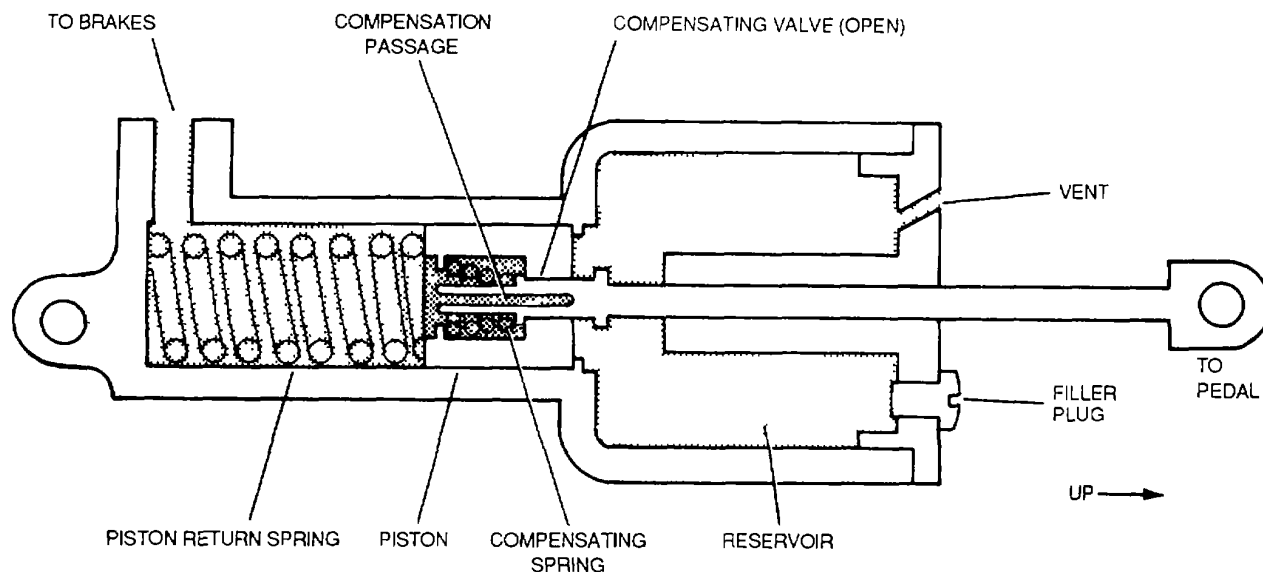
(2) *Servicing.* The air cylinders are charged through a ground test filler connection by a portable nitrogen cart or a high pressure air compressor. All nitrogen or air is filtered by a filter in the service line.

**4-18. Aircraft Brake Systems.** All hydraulic brake systems operate on the same basic principle. When the operator moves a brake pedal or other brake operating control, the movement is transmitted to a master cylinder or to a power brake control valve from which fluid pressure is delivered through connecting lines to a brake assembly connected to a wheel or shaft whose movement is to be braked. The fluid pressure acting on the brake assembly pushes brake linings into contact with surfaces of a rotating disc. The resulting friction slows--and finally stops--the continued rotation of the wheel or shaft to which the disc is connected. When the brake pedal or brake control is returned to the off position, brake operating pressure is relieved, the brake lining loses contact with the disc, and the wheel or shaft is free to turn again.

a. *Wheel Brake Systems.* Aircraft wheel brake systems are dual in nature in that they are composed of two identical subsystems that can be operated independently of each other to provide separate braking action for the landing gear on each side of the aircraft. Each subsystem is operated by a toe plate (brake pedal) that is hinge-mounted to the top of the aircraft rudder pedal. Since each brake pedal can be operated independently the brakes can be used for steering the aircraft. A list of components, which may be found in varying combinations to make up the different wheel brake systems, includes the following: master cylinder (or a power brake control valve), wheel brake assemblies, boosters, parking brake valves, shuttle valves, accumulators, connecting lines, and bottles charged with compressed air. The minimum number of parts which could be used to perform the function of a simple wheel brake system are a master cylinder (or a power brake control valve), a wheel brake assembly, and connecting lines.

(1) *Master cylinders.* Master cylinders are used in some wheel brake systems as the means of transforming force applied by the of the operator foot into fluid pressure; the greater the force applied to the pedal, the higher the fluid pressure. Master cylinders fall into three general classifications: simple, compound, and powerboost. Within these classifications, there are many variations in shape, size, and design, depending on the manufacturer and on how the cylinder functions in the brake system. Brake systems incorporating simple and compound master cylinders operate independently of any other hydraulic system within the aircraft and are sometimes called independent brake systems. In brake systems using a power boost master cylinder, some of the power needed for braking is supplied by a power-driven pump.

(a) *Simple master cylinder.* Some simple cylinders have integral reservoirs; others are connected with in-line reservoirs by means of a hose. In some designs, a push rod actuates the piston; in others a pull rod performs this function. The design shown in figure 4-148 has an integral reservoir, and the piston is actuated by a push rod. Note that the illustration shows the cylinder in released position, with the compensating valve open. This allows any thermally expanded fluid within a connected wheel brake assembly to pass freely into the reservoir and from the reservoir back into the assembly to replace fluid that may have been lost due to minor leakage. When the brake pedal is depressed, the first few thousandths of an inch of travel of the master cylinder push rod closes the compensating valve, thus trapping the fluid that lies between the underface of the piston and the wheel brake assembly. Further depression of the brake pedal moves the piston within its bore and forces fluid out of the master cylinder



**Figure 4-148. Simple Master Cylinder**

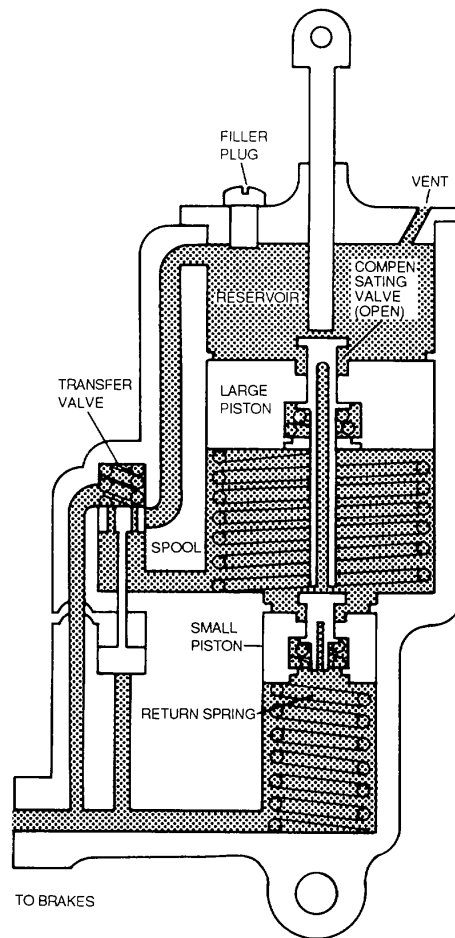
into the wheel brake assembly. Releasing the brake pedal retracts the master cylinder push rod, allowing the piston spring to open the compensating valve and to hold it open until the pedal is depressed again.

(b) *Compound master cylinder.* Some aircraft require wheel brake systems that operate with more fluid flow and higher fluid pressure than is within the capability of a simple master cylinder. In some types of aircraft, a compound master cylinder is used for this purpose. This type of master cylinder can deliver a large quantity of fluid at low pressure by means of relatively short pedal travel. It can also develop high operating pressure by means of moderate pedal pressure. This dual capability is achieved by means of two pistons: a large one for producing a large fluid flow with short travel; and a small one for developing high pressure from a lightly applied force. Figure 4-149 shows a compound master cylinder in a released position, which means that the compensating valves of both pistons are open to the reservoir.

1 *Brakes applied.* As the brake pedal is depressed, both compensating valves close and the pistons are forced ahead in their cylinder bores. The fluid displaced jointly by the two pistons flows into the wheel brake assembly, where it moves the linings into contact with the disk. A slight additional movement of the brake pedal and pistons raises the pressure in the system by a few pounds. This slight rise in pressure moves a spring-loaded spool in the transfer valve within the master cylinder. The new position of the spool blocks the flow of fluid from the large cylinder to the wheel brake assembly and opens a passage between the large cylinder bore and the reservoir, thus allowing any fluid displaced by the large piston to flow without resistance into the reservoir. The small cylinder bore remains open to the passage within the master cylinder through which fluid is delivered to the wheel brake assembly. As force applied to the brake pedal is increased so as to push the linings into hard contact with the brake disc, the two pistons move slightly farther into their bores. Since any fluid displaced out of its bore by the large piston is flowing to the reservoir without resistance, practically all the force exerted on the brake pedal is applied to the small piston.

2 *Brakes released.* Upon release of the brake pedal, the spool of the transfer valve returns to its spring-loaded position, the pistons return to their released position, the compensating valves open, and the fluid that was forced into the wheel brake assembly when the brake was applied returns to the master cylinder.

(c) *Power-boost master cylinder.* Some aircraft land at speeds too great to permit control of the aircraft by a brake system powered entirely by an operator's foot and leg muscles. The brake systems of such aircraft require power produced by a power-driven pump. In some aircraft, the pump-produced power does the job alone and is merely controlled by the operator. In other aircraft, the pump-produced power is used as a supplement (or boost) to the power supplied by the muscles of the operator; the power-boost master cylinder is used in these brake systems. In the event of

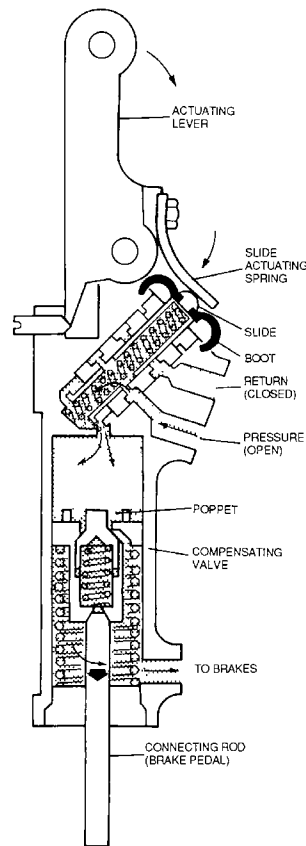


**Figure 4-149. Compound Master Cylinder**

loss of pump-produced power to the master cylinder, some brake application by muscle power alone is possible. However, considerably more force than normal has to be applied to the brake pedal to achieve the necessary braking action. In heavy aircraft the most vigorous manual applicator is still completely inadequate and an emergency source of boost pressure, such as an accumulator or a compressed-air bottle, has to be provided.

1 *Design.* Figure 4-150 shows a typical power-boost master cylinder. Note that two interconnected chambers make up the cylinder body. The upper chamber houses a spring-loaded sleeve and slide and the pressure and return ports for the main system lines. The lower chamber contains a spring-loaded piston and poppet and the port to the brake line. This chamber also serves as a reservoir for the fluid that energizes the brake when pressure is applied. An actuating lever and two slide actuating springs are mounted on top of the cylinder. One end of the actuating lever is secured to the aircraft, the other end, to the cylinder housing. It should be noted that the master cylinder described here has a piston rod that is pulled outward of the housing as the brake is applied. However, there is another design in which applying the brake pushes the piston rod inward.

2 *Fluid pressurization.* Applying pressure to the brake pedal creates a pull on the piston rod that results in downward movement of the piston. When sufficient movement of the piston occurs to release the poppet extension from its contact with the housing, the poppet seats, thereby closing the compensating valve. Fluid trapped between the underside of the piston and the wheel brake assembly then becomes pressurized. This fluid pressure, acting with force exerted by the piston retracting spring, creates a downward pull on the master cylinder housing. When the pull becomes sufficiently great, it causes the pivoted actuating lever to move from its previously angled position. The new position of the actuating lever forces the attached slide actuating springs to retract the slide, thereby causing the slide to block the return port and to open the pressure port. This allows pressure from the system pump to pass through the pressure port and the slide and to enter the chamber above the piston. This pressure exerts a downward push on the piston, which aids the muscle (operator) produced pull on the piston in developing brake application pressure within the lower chamber and the connected wheel brake assembly. Whatever pressure is present in the chamber above the piston is also present within the slide and tends to force the slide upward against the resistance of the slide actuating springs. When the pressure-produced force



**Figure 4-150. Power-Boost Master Cylinder (Brake Applied)**

acting on the slide becomes slightly greater than the force exerted by the slide actuating springs, the slide moves upward to the extent that it blocks both the pressure and return ports.

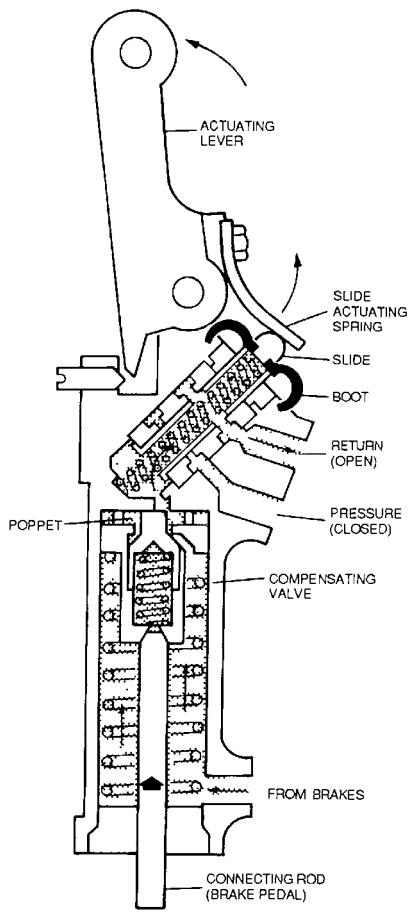
3 *Pressure maintenance.* Since no pressure can then be relieved or increased within the chamber above the piston, brake application remains constant as long as the operator does not change the force applied to the brake pedal. The degree of brake application is under complete control of the operator and is determined by the amount of pressure he applies to the brake pedal.

4 *Brake release.* Release of pressure on the brake allows the piston spring to retract the piston, which results in reopening the compensating valve (see figure 4-151). This allows the actuating lever to return to its angled position, thereby permitting the slide to return to the position, thereby permitting the slide to return to the position in which it blocks the pressure port and opens the return port. Fluid that was forced into the wheel brake assembly during brake application can then return to the chamber on the underside of the piston and thus release the brake.

(2) *Power control valves.* In aircraft that land at high speed, power brake control valves are used instead of master cylinders to provide the wheel brake assemblies with fluid pressure. The main difference between a power brake control valve and a master cylinder lies in the pressure source. A power brake control valve produces no pressure. It is pressure to a wheel brake assembly. Since the power brake control valve does not produce pressure, a brake system using this type of valve must be supplied with an emergency source of input pressure, such as an air bottle, for use in the event that the regular pressure source fails.

(a) *Brake application.* When the brake pedal is depressed, the plunger moves toward the left as shown in figure 4-152. This movement is transmitted to the spool by the spool pressure spring causing the spool to move toward the left if the brake pedal is depressed only a minimum amount, the spool's leftward movement is just enough to barely unblock the pressure port. This movement of the spool interconnects the pressure and brake lines and isolates the brake line from the return line. As a result fluid flows out of the brake port into the brake assembly, thus raising the pressure in the wheel brake assembly and causing the brake to be applied. The rise in pressure in the wheel brake assembly takes place gradually because of the very small opening between the spool and the pressure





**Figure 4-151. Power-Boost Master Cylinder (Brake Released)**

port. Whatever amount of pressure is present in the wheel brake assembly at any given moment is also present in the hollow of the spool, having entered the spool through a cross-drilled hole. This pressure within the spool tends to move it toward the right. This is in opposition to the force exerted by the spool pressure spring and reblocks the pressure port. The amount of fluid pressure that has to be present at any given time in the wheel brake assembly and in the spool to cause reblocking of the pressure port depends on the amount of force in the spool pressure spring at that time. Since the amount of force exerted by the spool pressure spring is in proportion to the distance the brake pedal is depressed, the degree of pressure with which the brake is applied depends on how far the pedal is depressed.

(b) *Pressure maintenance.* Once a given degree of braking effort has been obtained by depressing the pedal a given distance, it will remain unchanged as long as the pedal is not moved. This is because the movement of the spool to the right in blocking the pressure port leaves the brake line isolated from both the pressure and the return lines. Thus, no fluid can enter or leave the wheel brake assembly and change the amount of pressure therein unless the position of the spool is changed by moving the pedal. When the brakes are in this static condition, the operator may experience the illusion that he is still applying the brakes. The reason for this is that the fluid pressure within the spool that tends to move the spool toward the right is transmitted back to the brake pedal through the spool pressure spring and the plunger. This results in a push of the pedal against the operator's foot, giving him the feeling that he is applying the brakes.

(c) *Brake release.* As shown in figure 4-153, releasing the brake causes the plunger spring to move the plunger toward the right. This releases pressure on the spool pressure spring and permits the spool return spring to move the spool toward the right. Under these conditions the pressure port is blocked and the brake line and the return line are interconnected. The fluid that was forced into the wheel brake assembly when the brake was applied now returns to the reservoir.

b. Wheel Brake Assemblies. The wheel brake assembly is that portion of a wheel brake system that receives pressure from a master cylinder or a power brake control valve and converts the pressure into a retarding force that stops wheel rotation.

(1) *Disc brakes.* A typical disc assembly is shown in figure 4-154. In a disc assembly, one or two steel discs are generally used, depending on the type

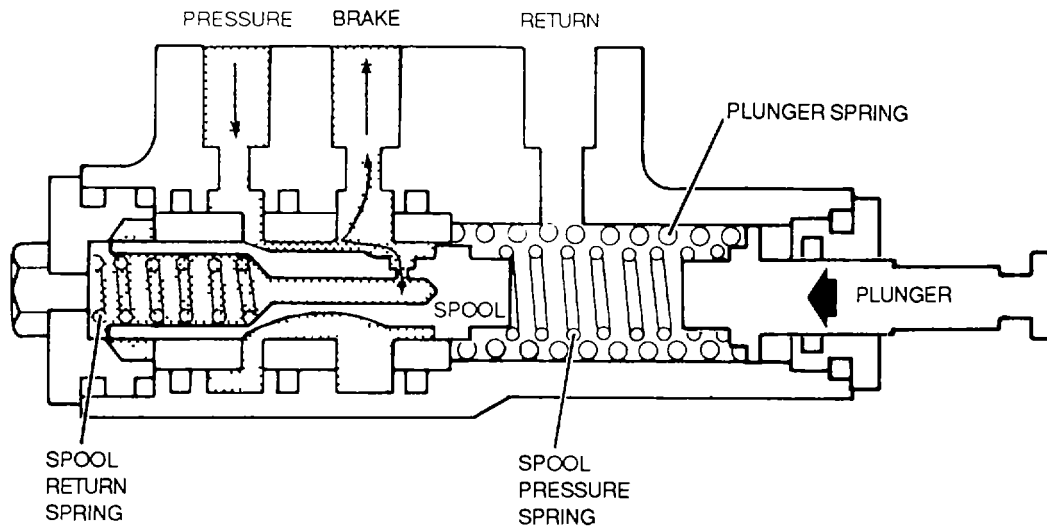


Figure 4-152. Power Brake Control Valve (Brakes Applied)

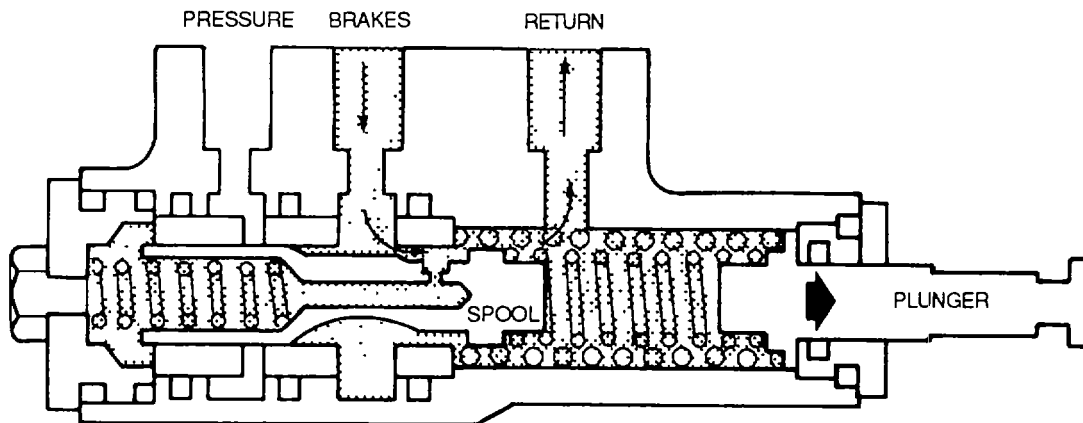
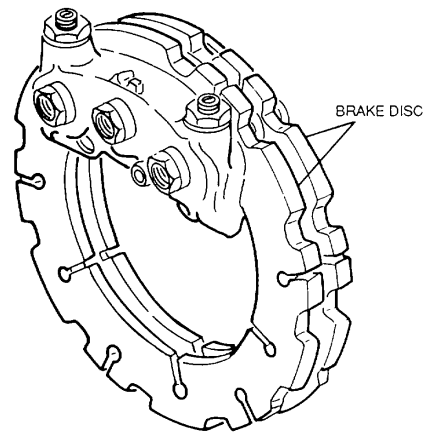


Figure 4-153. Power Brake Control Valve (Brakes Released)

and size of the aircraft on which the brakes are installed. These discs are keyed to the wheel and rotate with the wheel. The brake piston housing, which is securely bolted to the torque plate of the aircraft landing gear, contains from one to four brake actuating pistons, the number depending on the type and size of the aircraft. Depressing a brake pedal forces hydraulic fluid through connecting lines to the wheel brake assembly and into each piston cavity. This forces the piston and the outboard brake lining against the brake disc. Since the disc is free to move from side to side along the lugs in the wheel, it is forced against the inboard brake lining. The friction that results from this clamping of the rotating disc between a pair of linings retards the continued rotation to the disc and of the wheel to which it is attached.

(a) *Single-disc.* Figure 4-155 shows a cross-section of a single-disc brake. This brake, like most hydraulically operated disc brakes, is self-adjusting. The illustration shows a cutaway of only one piston cavity. However, all piston assemblies of this type of brake are nearly identical.

1 *Application.* Application of the single-disc brake occurs when hydraulic fluid under pressure enters the fluid port (7). This pressure forces the piston (5) to the left against spring pressure until the spring guide (6) contacts the flanged side of the adjusting pin (8). In moving this distance, the piston has forced the outboard brake lining (4) against the steel disc (3), which in turn moves sideways on its keys and contacts the inboard brake lining (2)



**Figure 4-154. Disc Brake Assembly**

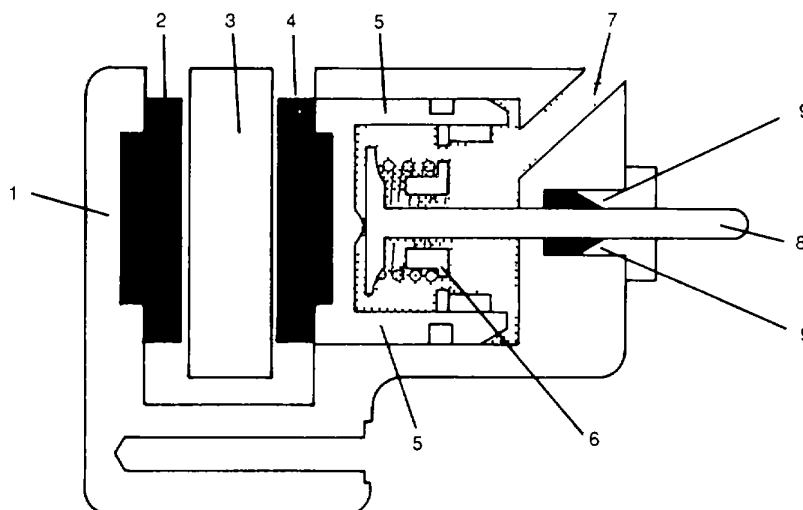
supported by the backing plate (1). The brake running clearance is thus taken up by this first movement of the piston. However, to obtain full braking friction between the rotating disc and the lining "pucks", the piston must move farther to the left. The disc must be firmly pinched between the lining "pucks". The spring guide is already contacting the face of the adjusting pin, and the adjusting pin is held firmly by the friction of the adjusting pin grip (9). However, pressure on the piston provides enough force to overcome this friction, allowing the piston and pin to move farther to the left. If the brakes are held in this applied position, the lining wears away. The pin continues to move inward slowly to compensate for the small amount of lining wear.

2 *Release.* Each time the brakes are released, the piston backs away from the outboard lining block. It can move until the back of the piston head contacts the face of the adjusting pin. The piston always releases to give the same running clearance. The self-adjusting pin grip prevents the pin from moving to the right.

(b) *Dual-disc.* Dual-disc brakes, which are always multiple piston types, are used on aircraft requiring more braking friction at lower pressure than single disc brakes provide. Pressure applied to the pistons of this type of brake pushes their attached linings against the brake disc nearest the pistons. That disc is then forced against the brake linings on its side of the center carrier assembly. This forces the center carrier assembly and its second set of brake linings against the second disc. The second disc is then forced against the brake linings in the anvil. In this manner, each brake disc receives equal braking action on both sides when the brake is operated. When brake pressure is released, the return springs within the self-adjusting mechanism in each cavity retract the pistons.

(2) *Parking brake valves.* Parking brake valves are used on some aircraft wheel brake systems as a means of trapping fluid pressure in the wheel brake assemblies to keep the brakes applied for parking. Individual and dual type valves are commonly used. Because the dual type is basically a combination of two individual valves, this explanation of the dual valve will illustrate the operation of both types.

(a) *Operation.* The typical dual parking brake valve shown in figure 4-156 incorporates two spring-loaded pistons in compensator cylinders, which provide an automatic means of compensating for changes in hydraulic oil volume caused by temperature



**LEGEND**

- 1 BACKING PLATE
- 2 INBOARD BRAKE LINING
- 3 DISC
- 4 OUTBOARD BRAKE LINING
- 5 PISTON
- 6 SPRING GUIDE
- 7 FLUID PORT
- 8 ADJUSTING PIN
- 9 ADJUSTING PIN GRIP

**Figure 4-155. Disc Brake Assembly Cross Section**

changes or minor leakage. During normal braking of the aircraft by pedal actuation, the lever of the parking brake valve is held in the off position by means of a spring. The camshaft to which the lever is attached holds the two outer poppets of the valve unseated as shown here. This permits fluid pressure from the master cylinder or power brake control valve to pass straight through the parking brake valve to the wheel brake assemblies. In this position, the inner poppets are seated and the spring-loaded pistons are inoperative.

(b) *Setting parking brakes.* To set the brakes for parking, the parking brake valve is left in the off position until the brake pedals are depressed (see figure 4-157). While the brake pedals are still depressed, the parking brake control handle is pulled to the park position. This rotates the camshaft of the valve, causing the outer poppets to seat as shown in figure 4-158, fluid pressure is now locked within the wheel brake assemblies. At the same time, the rotating camshaft unseats the inner poppets, thereby opening the compensator cylinders to the wheel brake assemblies. As a result, the compensator cylinders become charged, the pistons become partially retracted, and the springs become partially compressed. Spring tension on the spring-loaded pistons maintains constant braking pressure by compensating for volume changes produced by changes in temperature and by minor leaks.

(c) *Brakes locked.* After the parking brake has been set in the park position, the brake pedals are released. The parking brake lever then becomes locked in the park position by means of a locking pin, which is extended to the locking position by a spring. The locking pin is retracted, permitting release of the lever by fluid pressure, when the brake system is pressurized by operating the brake pedals.

c. *Helicopter Rotor Brake Systems.* Rotor brake systems are installed on some helicopters as a means of shortening the time required to bring their rotor assemblies to rest after power has been shut off. They also prevent the rotor assemblies of parked helicopters from windmilling. A basic hydraulic rotor brake system is shown in figure 4-159. Newer helicopters have more complex systems, but the same basic principles apply.

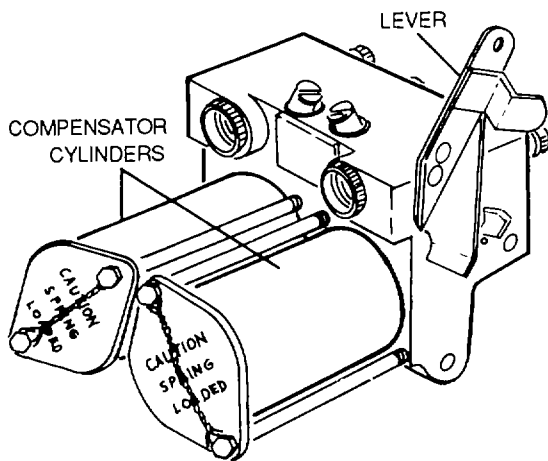


Figure 4-156. Dual Parking Brake Valve

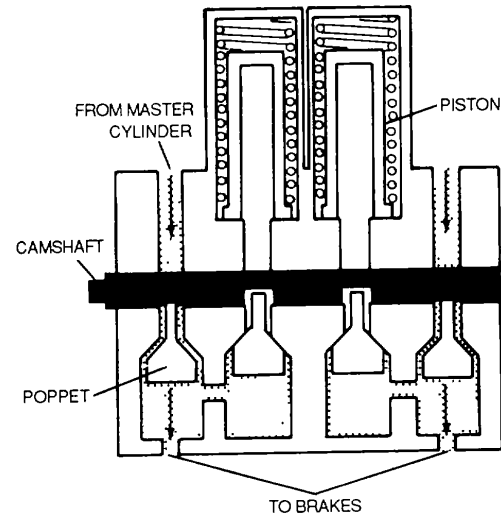


Figure 4-157. Dual Parking Brake Valve (Off)

(1) *Brake application.* To apply the rotor brake, the master cylinder handle is slowly pushed downward and forward. This results in a movement of the master cylinder piston that forces fluid out of the master cylinder and into the rotor brake cylinders. Movement of the fluid causes the pistons and brake linings of each pair of brake cylinders to move toward each other. This produces a clamping action on the rotor brake disc which stops its rotation. The master cylinder handle is automatically locked in the brake on position for parking the aircraft by means of a spring-loaded latch.

(2) *Brake release.* To release the brake, the spring-loaded latch has to be pulled outward to disengage it from the handle. A spring-loaded detent helps to hold the handle in the released position.

d. *Maintenance of Brake Systems.* Proper functioning of the aircraft brake system is of utmost importance. Failure of any component within the system could result in destruction of equipment and loss of life.

(1) *Inspection.* Inspections must be conducted at frequent intervals and maintenance work which might be indicated must be performed promptly and carefully. The system should be under operating pressure when it is being checked for leaks, but loose fittings must be tightened with the pressure off. All flexible hoses should be carefully checked for swelling, cracking, and soft spots and should be replaced. If evidence of deterioration is noted. The proper fluid level must be

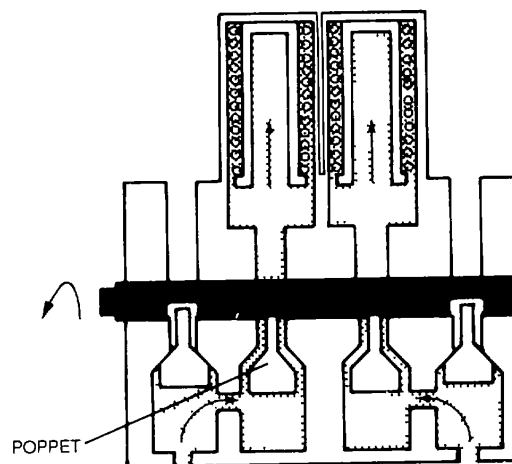


Figure 4-158. Dual Parking Brake Valve (On)

maintained at all times to prevent brake failure or the introduction of air into the system. Air in the system is indicated by a spongy action of the brake pedals. If air is present in the system, it must be removed by bleeding.

(2) *Bleeding.* There are two general methods of bleeding brake systems: pressure bleeding, and gravity bleeding. The method used usually depends on the type and design of the brake system, but may be dictated by availability of required equipment. Specific instructions are found in the aircraft technical manual.

(a) *Pressure bleeding.* In the pressure method, shown in figure 4-160, air is expelled through the brake system reservoir or a bleeder valve located somewhere within the system. Pressure is supplied by a pressurized hydraulic fluid dispenser. Pressurized fluid flows completely through the system, unit all air is expelled.

(b) *Gravity bleeding.* In the gravity method, the air is expelled from the system through one of the bleeder valves on the brake assembly. As shown in figure 4-161, a bleeder hose is attached to the bleeder valve and the free end of the hose is placed in a container holding enough hydraulic fluid to cover the end of the hose. The air-laden fluid is then forced from the system by applying the brakes. If the brake system is part of the main hydraulic system, a portable hydraulic test stand may be used to supply the pressure. If the system is an independent master cylinder system the master cylinder will supply the necessary pressure. In either case, each time the brake pedal is released, the bleeder valve must be closed; otherwise air will be drawn back into the system. Bleeding should continue until no more air bubbles come through the bleeder hose into the container.

(3) *Troubleshooting.* Table 4-41 lists common troubles found in wheel brake systems, and table 4-42 describes those found in helicopter rotor brake systems used on Army aircraft.

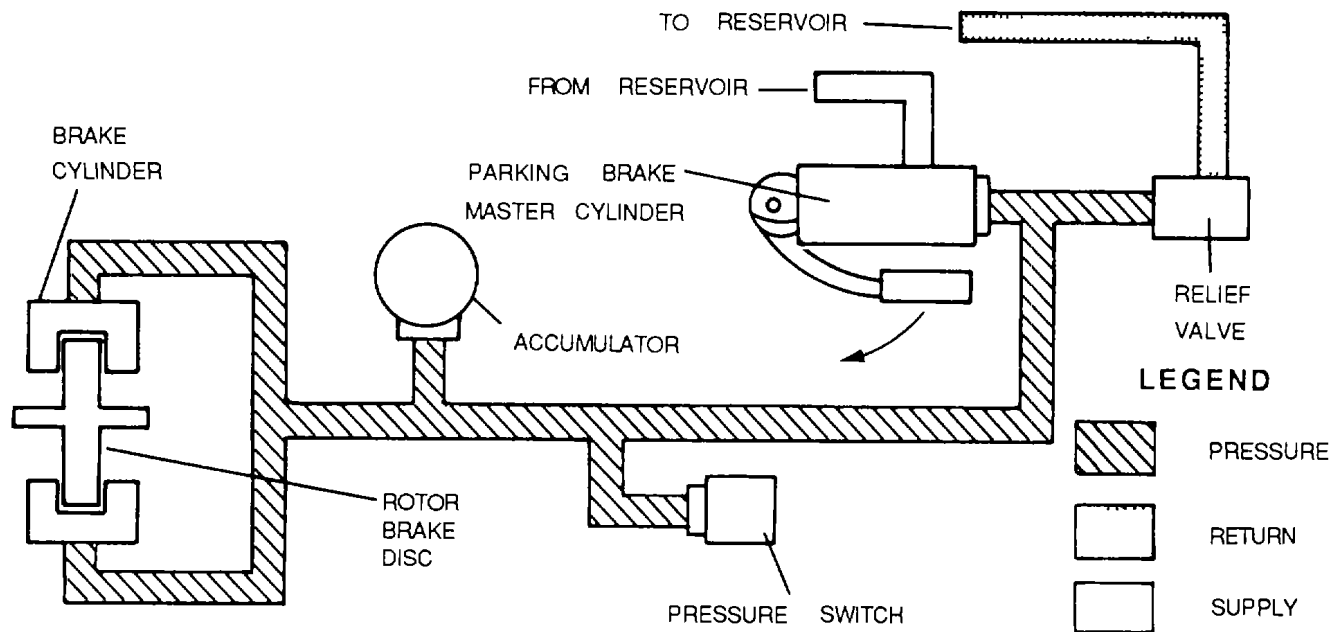
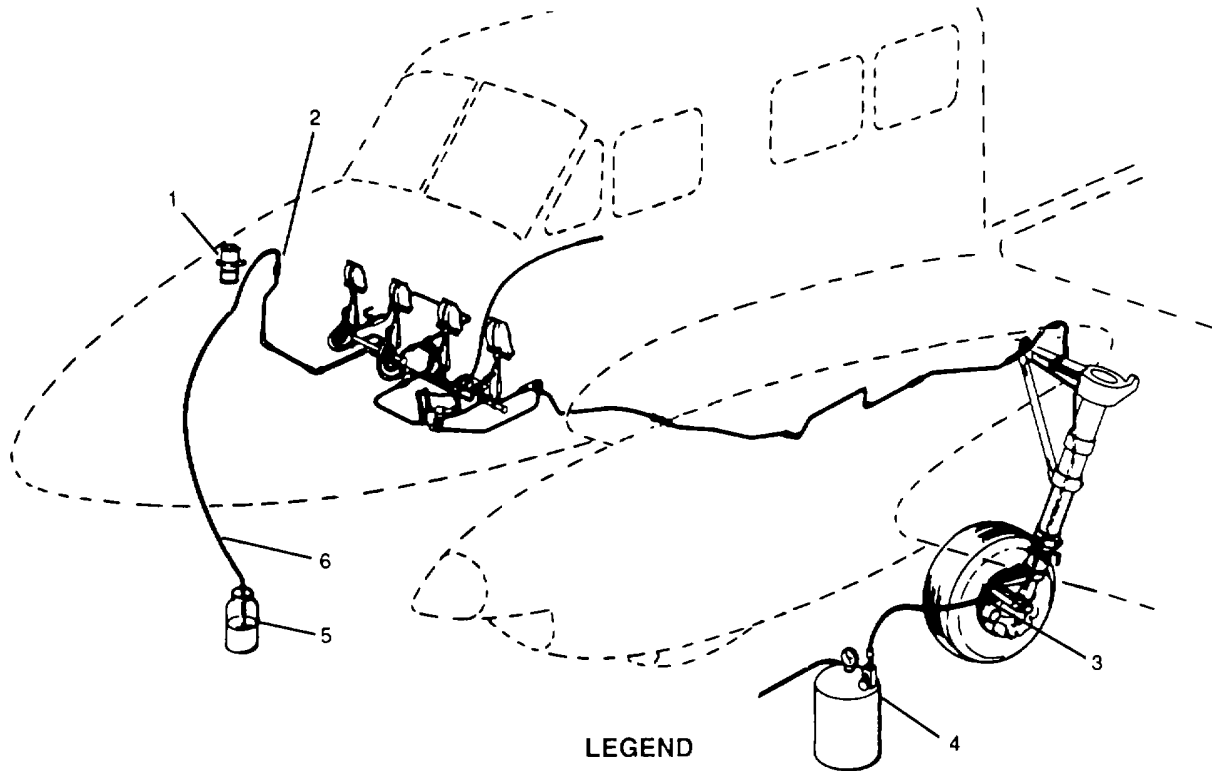


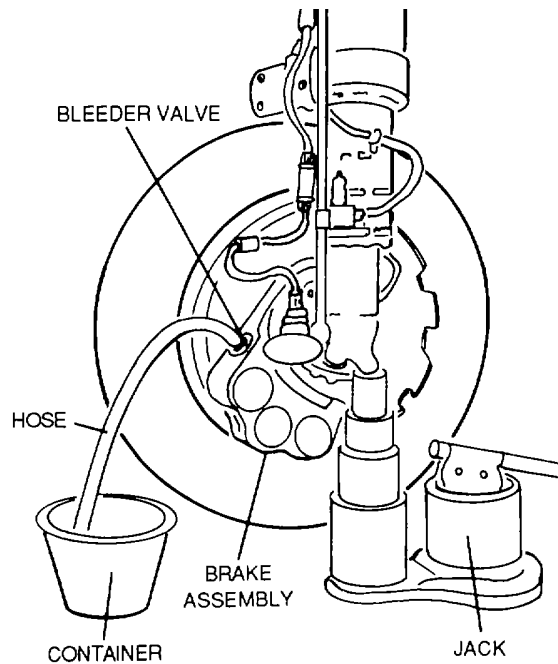
Figure 4-159. Rotor Blade Brake System



**LEGEND**

- |   |                     |   |                       |
|---|---------------------|---|-----------------------|
| 1 | HYDRAULIC RESERVOIR | 4 | PRESSURE BLEEDER TANK |
| 2 | TUBE ASSEMBLY       | 5 | CONTAINER             |
| 3 | BLEEDER VALVE       | 6 | FLEXIBLE HOSE         |

**Figure 4-160. Bleeding Brake Hydraulic System**



**Figure 4-161. Gravity Method for Brake Bleeding**

**Table 4-41. Troubleshooting Wheel Brake Systems**

<b>Trouble</b>	<b>Probable Cause</b>	<b>Remedy</b>
Brakes do not hold	Air in system.	Bleed system.
	Leaks in system.	Check for leaks and tighten all fittings.
	Worn brake linings.	Replace brake linings as necessary.
	Oil or grease on brake linings.	Replace brake linings as necessary.
	Leak in master cylinder or power brake control valve.	Replace master cylinder or power brake control valve and bleed system.
Brakes grab	Stones or other foreign matter locking brake disc	Clean brake disc brake linings.
	Warped or bent brake disc	Replace brake disc
Brakes will not release	Parking brake stuck.	Replace parking valve and bleed system.
	Blockage in master cylinder or power brake control valve	Replace master cylinder or power brake control valve and bleed system.
Dragging brakes	Warped disc.	Replace disc.
	Automatic adjusting mechanism faulty.	Replace adjusting mechanism or brake assembly.
Excessive force required on brake pedals of power-boost brake system to apply brakes	Power-boost master cylinder inoperative	Replace power boost master cylinder and bleed system
	Excessively worn brake linings	Replace brake linings.
	Failure of main or utility hydraulic system pressure	Check main or utility hydraulic system and correct defect
Parking brake will not hold	Air in system.	Bleed brakes
	Defective parking brake valve. bleed system.	Replace parking brake valve and bleed system.



**Table 4-41. Troubleshooting Wheel Brake Systems - CONT**

<b>Trouble</b>	<b>Probable Cause</b>	<b>Remedy</b>
Pedals bottom, no brakes	Broken or leaking brake line.	Replace damaged line and bleed system
	Master cylinder or power brake control valve defective system.	Replace master cylinder or power brake control valve and bleed
	Excessively worn brake linings.	Replace brake linings.
Solid pedal and no brakes	Air In system.	Bleed brakes
	Too little fluid in system Excessively worn brake linings or grease on brake linings.	Replenish supply and bleed brakes. Replace brake linings
Spongy brakes	Air In system	Bleed brakes.
Low hydraulic fluid level	Replenish supply	
Unable to hold pressure evidence of leaks.	Leak In brake system	Visually check entire system for
	Master cylinder or power brake control valve defective	Replace master cylinder or power brake control valve and bleed system
Uneven braking	Worn brake linings.	Replace brake linings.
Worn brake disc.	Replace brake disc.	
Air in system	Bleed system.	
	Leaking line connection. system.	Tighten connection and bleed
	Worn or damaged pressure relief valve	Replace pressure relief valve and bleed system
Weak braking	Air in system.	Bleed system
	Master cylinder or power brake control valve defective. system	Replace master cylinder or power brake control valve and bleed
	Insufficient supply of hydraulic fluid.	Replenish supply

**Table 4-42. Troubleshooting Rotor Brakes Systems**

<b>Trouble</b>	<b>Probable Cause</b>	<b>Remedy</b>
Brake does not hold	Brake cylinders improperly adjusted.	Adjust cylinders
	Leakage in lines	Repair or replace as necessary
	Defective accumulator. accumulator If necessary.	Check air pressure, replace
	Accumulator air pressure escaping into brake lines (brake off over a prolonged period)	Service accumulator and bleed air out of brake lines.
	Internal or external leakage in master cylinder	Replace master cylinder
Brake does not release (lining)	Low oil level In utility reservoir.	Service reservoir.
	Improper internal adjustment drags on disc).	Replace brake cylinder. of brake cylinder
Clutch pump operates with rotor brake on.	Brake disc warped	Replace disc
	Defective rotor brake limit switch.	Check prime power source and continuity; replace switch If necessary.
	Open circuit breaker	Reset circuit breaker.
Spongy brake.	Defective clutch control relay	Replace relay
	Air in lines	Bleed air at master cylinder and/or brake cylinders.
Brake cylinders Improperly adjusted.	Adjust brake cylinders	
Master cylinder handle does not lock in parked position (when not made inoperative by latch)	Defective latch.	Replace master cylinder.
Master cylinder handle does not release	Defective latch.	Replace handle.

**4-19. Dampening and Absorbing Units.** Dampening and absorbing units retard the motion of moving objects to which they are attached. These units perform this function by removing some of the energy of motion and converting it to heat. The heat is then dissipated into the atmosphere. Dampening and absorbing units used in Army aircraft are hydraulic dampers, shock struts, and liquid springs.

a. *Hydraulic Dampers.* A damper is a device for controlling the speed of relative movement between two connected objects. Usually, one end of the damper is connected to a fixed member; the other end, to a movable part. The reacting parts of the damper move against considerable resistance. This resistance slows the speed of relative movement between the objects. Hydraulic dampers used in Army aircraft operate either by displacing fluid or by shearing fluid.

(1) *Displacement-principle dampers.* Displacement-principle dampers used in Army aircraft are of two types—piston and vane. Though different in construction, both types have the same basic design characteristics—a sturdy metal container with a sizeable inner space divided into two or more chambers. The chambers vary in size according to the position of parts within the damper. The chambers must be completely filled with fluid in order to operate properly.

(a) *Piston damper.* A typical piston damper is shown in figure 4-162. Note in figure 4-163 that the piston and rod assembly divides the space within the damper housing into two chambers. Seal rings on the piston prevent fluid leakage between the chambers. An orifice permits fluid to pass with restricted flow from one chamber to the other. A filler port (not shown) provides for servicing the damper with fluid.

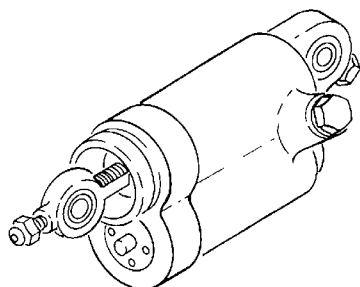
1. *Operation.* As the piston is forced to the right, chamber 2 decreases in proportion to the distance the piston is moved. Simultaneously, chamber 1 increases by a comparable size. The hydraulic fluid displaced from chamber 2 flows through the restricting orifice into chamber 1. When the piston is moved toward the left, reverse changes occur in the chamber sizes and in the direction of fluid flow. The restriction of the fluid flow by the orifice shows the rate of speed at which a given amount of force can move the damper piston. The rate at which a damper moves in response to a force is called damping rate or timing rate. In some dampers, the opening is of fixed size and timing rate is not adjustable. In other dampers, the orifice size is adjustable to allow for timing adjustments.

2. *Nose landing gear damper.* The nose landing gear of an aircraft has a tendency to shimmy when the aircraft is taxiing at any appreciable speed. A damper is used as shown in figure 4-164 to eliminate wheel shimmy without interfering with the normal steering movements on the nose wheel.

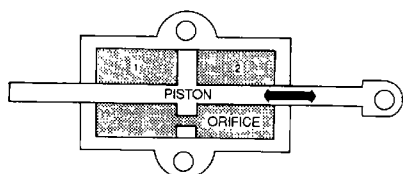
3. *Rotor blade damper.* Piston-type dampers are used on helicopter rotor head assemblies and on tail rotor hub assemblies to control lead-lag movements of rotor blades. Note in figure 4-165 how the dampers are connected. Lead-lag movements of rotor blades occur in cases in which there are three or more blades in a set and the blades are hinged to the rotor head.

(b) *Vane damper.* A typical vane-type damper is shown in figure 4-166. This type of damper consists basically of a cylindrical housing having a polished bore with two stationary vanes (called abutments) and having a shaft supporting two movable vanes. Together the four vanes split the cylinder bore lengthwise into four chambers as shown in figure 4-167. The two stationary vanes are attached to the damper housing. The two movable vanes, along with the shaft, make up a unit called a wing shaft. The wing shaft rotates between the abutments. One end of the wing shaft is splined and protrudes through the damper housing. A lever arm, attached to the splined end, is the means of rotating the wing shaft.

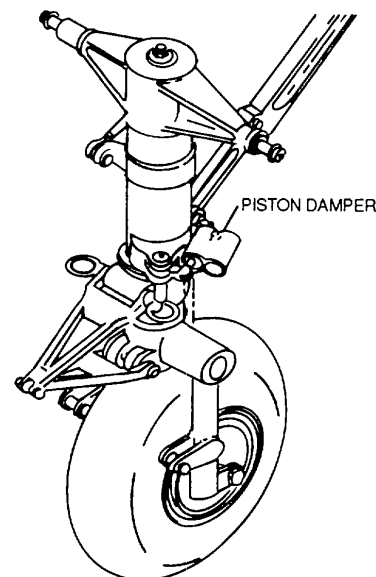
1. *Operation.* The damper chambers are completely filled with fluid, and at any instant of damper motion the fluid is subjected to forced flow. As the wing shaft rotates, fluid flow between the chambers takes place through an opening within the wing shaft, which interconnects the four chambers. Thus a restraining force is developed in the damper, dependent on the velocity of fluid flow through the orifice. Slow relative movement between the wing shaft and the damper housing causes a low velocity flow through the opening and little resistance to damper arm rotation. More rapid motion of the wing shaft increases the speed of fluid flow and thus increases resistance to damper arm rotation. The timing rate of vane-type dampers can be adjusted by a timing adjustment centrally located in the exposed end of the wing shaft. This adjustment (not shown) sets the effective size of the opening through which fluid flows between chambers and thus determines the speed of movement with which the damper will respond to an applied force.



**Figure 4-162. Piston Damper**



**Figure 4-163. Piston Damper Cross Section**



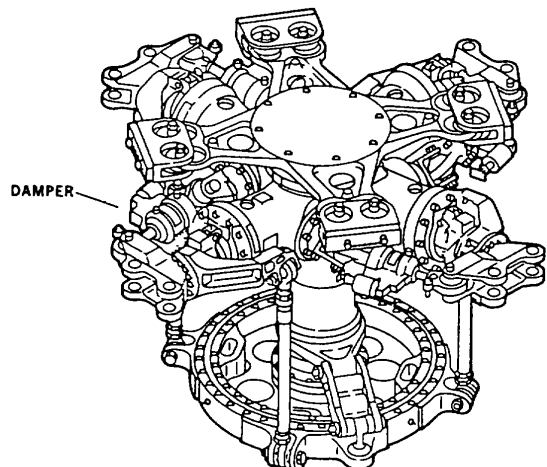
**Figure 4-164. Nose Landing Gear with Piston Damper**

2 *Nose landing gear damper.* Vane-type dampers, such as the one shown in figure 4-168, are used on the nose landing gear of some aircraft to eliminate the shimmy tendency.

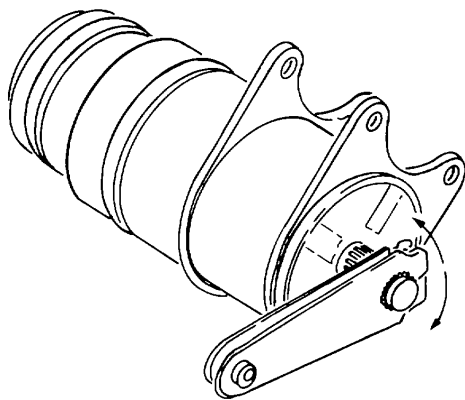
3 *Stabilizer bar damper.* Some helicopters have vane-type dampers, such as the one shown in figure 4-169, that serve to control the degree of sensitivity with which a helicopter responds to movement made by the pilot on the flight controls. These dampers are mounted on a bracket attached to the helicopter mast (main shaft). The damper arms are interconnected with other parts of the flight control system.

(2) *Shear-principle dampers.* In dampers operating on the shear principle, fluid is not forced out of one space and into another within the damper as in the case of displacement dampers. Instead, action on the fluid involves tearing (shearing) a thick film of highly viscous fluid into two thinner films that move with resistance in opposite directions. A highly viscous fluid is thick bodied, syrupy, and sticky.

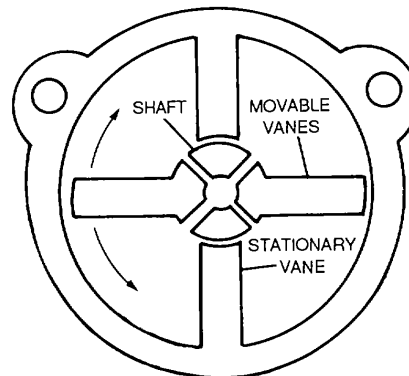
*Theory of operation.* In a shear-principle damper, two reacting parts are free to slide or rotate past each other as the damper operates. The surfaces facing each other are relatively smooth, and between them there is a preset gap of a few thousandths of an inch. This gap is filled with a highly viscous fluid. As the parts of the damper move relative to each other, the film of fluid between them shears into two thinner films. Each film adheres to and moves along with one of the parts. It is the friction within the fluid itself that causes resistance to movement of the parts to which the films adhere. To better understand this principle, imagine a puddle of syrup spilled on a relatively smooth table top. A sheet of paper placed on top of the puddle would move with considerable drag. This is very much like what happens between the parts of a shear-principle damper as the damper operates.



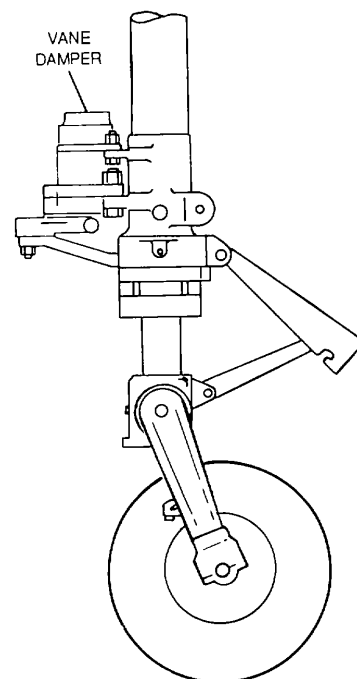
**Figure 4-165. Main Rotor Assembly with Piston Dampers**



**Figure 4-166. Vane Damper**



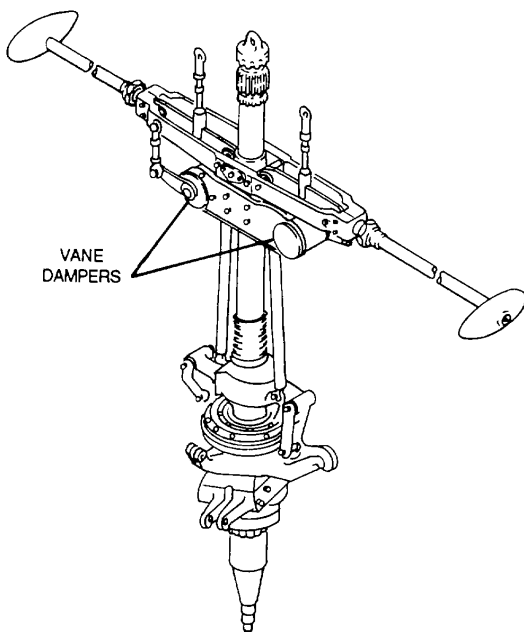
**Figure 4-167. Vane Damper Cross Section**



**Figure 4-168. Nose Landing Gear with Vane Damper**

*b Shock Struts.* A shock strut can be thought of as a combination suspension unit and shock absorber. The shock strut performs functions in an aircraft similar to those performed in an automobile by the chassis spring and the shock absorber. There are two major types of shock struts, the classification depending on construction and operation. In the mechanical type, a rubber or spring mechanism performs the cushioning operation. In the pneumatic type, air and hydraulic fluid accomplish this.

(1) *Simple shock strut.* The basic parts of a simple shock strut are two telescoping tubes: a piston and a cylinder. A simple shock strut is installed in an aircraft as shown in figure 4-170 with the piston uppermost and with the cylinder filled with fluid. An orifice in the piston head permits fluid to pass from one chamber to the other. When a shock strut has sufficient fluid above the piston head, the space above the fluid is filled with air. When the aircraft is landing and the shock strut



**Figure 4-169. Stabilizer Bar with Vane Dampers**

is compressing, fluid is forced through the orifice into the piston. The movement of fluid through the orifice, together with the compression of the air, absorbs the energy of motion of the descending aircraft. When the load on the shock strut is lightened, the shock strut extends. This extension is caused by the force exerted by the compressed air in the shock strut and, during takeoff, by the weight of the lower tube and the attached landing gear. When the shock strut is extending, fluid in the piston passes through the orifice from the piston into the cylinder.

(2) *Complex shock strut.* Complex shock struts work in essentially the same manner as simple ones. However, they contain, in addition to two telescoping tubes, a number of parts that make for more effective damping action than is possible with simple struts. Design features found singly or in combination in complex shock struts are metering pins, plungers, and floating pistons.

(a) *Metering pin.* The metering pin is a means of changing the effective size of the orifice so as to vary the rate of fluid flow from one chamber of the shock strut to the other. The diameter of the metering pin varies along its length, being almost equal at the ends and smaller in the middle. Note in figure 4-171 that

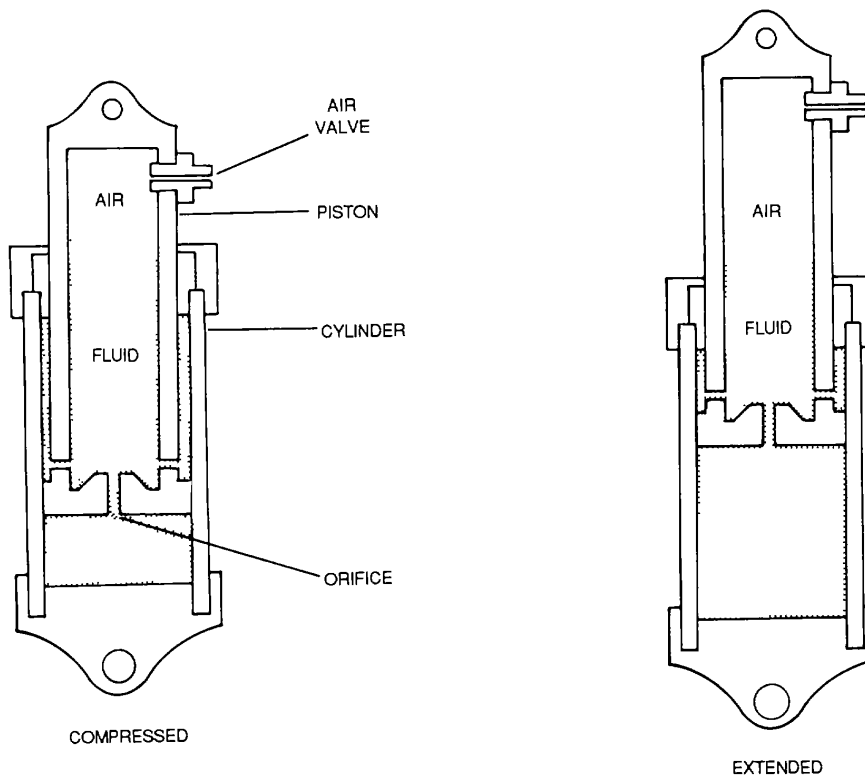
the unanchored end of the metering pin is located in the orifice when the shock strut is fully extended. The large diameter of the pin at this end provides a high resistance to fluid flow, a condition that is required during landing. The small diameter portion of the metering pin is located within the orifice when the shock strut is in its taxi position (partially compressed). This provides the low resistance to fluid flow that is required for taxiing. The portion of the metering pin nearest its anchored end lies within the orifice when the shock strut is completely compressed. The large diameter of the metering pin at this end provides increased resistance to fluid flow. The design of the pin at this end ensures against bottoming of the shock strut during unusually hard landings. The gradual increase in the diameter of the pin toward the anchored end prevents a sudden change in resistance to fluid flow.

(b) *Plunger.* Some complex shock struts are mounted on the aircraft with their cylinders uppermost as shown in figure 4-172. In such a unit, a plunger anchored in the cylinder extends downward into the piston. The plunger forces fluid out of the piston and into the cylinder during compression of the shock strut. The plunger is hollow, and fluid enters and leaves its interior through an orifice and through holes in its walls.

(c) *Floating piston.* In some shock struts, the air charge is carried at the bottom of the shock strut instead of at the top. Since air normally rises to the top of a liquid, some means must be provided to keep the air below the liquid. A floating piston serves this purpose. In the floating-piston type shock strut, the upper chamber of the strut decreases in size as the strut compresses as shown in figure 4-173. This is because compression of the shock strut forces fluid downward out of the upper chamber into the lower fluid chamber. The increase in size of the lower fluid chamber, necessary for accommodating the inflow of fluid, is obtained by downward movement of the floating piston. Thus, in addition to holding the air below the fluid, the floating piston contributes to the movement of fluid through the orifice as the shock strut compresses and extends.

(3) *Uses of shock struts.* Shock struts support the static load of the aircraft, cushion jolts during taxiing or towing, and absorb the shock of landing.

(a) *Supporting static loads.* The normal load of a parked aircraft is static; that is, the force present is fixed. The pressure of the air and fluid within a shock strut tends to keep the shock strut fully extended. However, air pressure in a shock strut is not enough to keep the strut fully extended while supporting the static load



**Figure 4-170. Simple Shock Strut**

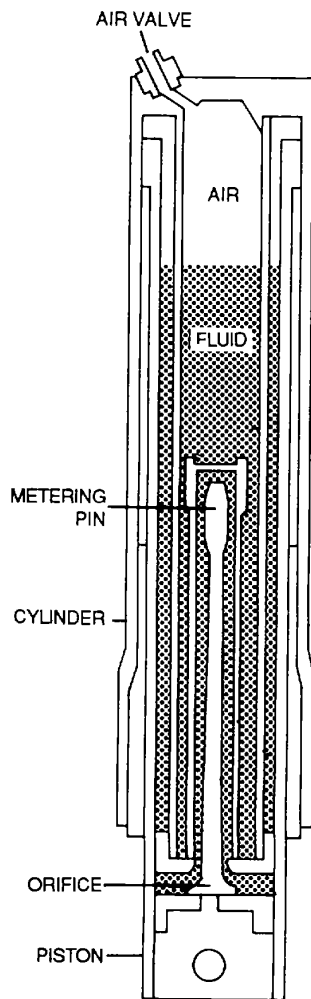
of an aircraft. Therefore, a shock strut gives under load and compresses until the air pressure builds enough to support the aircraft

*(b) Cushioning during taxiing.* As an aircraft taxis, the unevenness of the runway surface causes the aircraft to bob up and down as it moves forward (sometimes air currents contribute to this effect) The inertia of the aircraft fuselage in opposition to such up-and-down movements causes the force of the taxi load to fluctuate This bouncing motion is held within limits by the damperlike action of the shock strut. This dampening results from resistance created by the back-and-forth flow of fluid through the orifice as the shock strut extends and compresses.

*(c) Reducing shock during landing.* The aircraft will continue to descend at a high rate when landing, even after the wheels touch the ground. In the few remaining inches that the fuselage can move toward the ground after the wheels touch, the descent of the

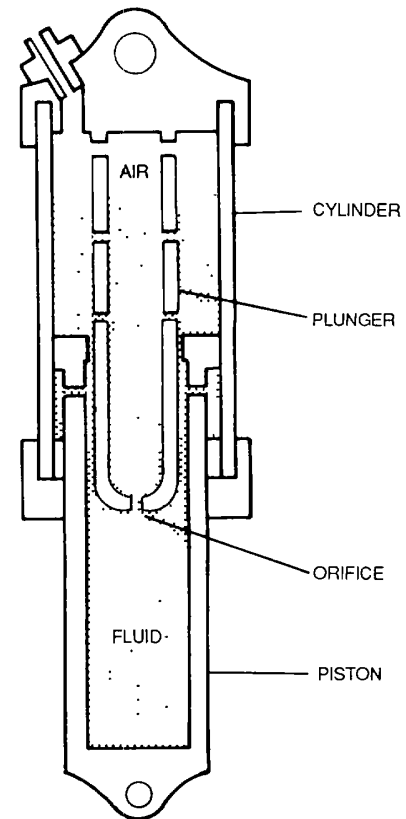
aircraft must be stopped. To perform this task, the shock strut must remove a great amount of energy from the downward movement of the aircraft. The impact force is very great compared to the force exerted by the mere weight of the aircraft. The shock strut removes some of the energy of motion-and thus some impact force-by converting energy into heat and dissipating the heat into the atmosphere. The resistance to fluid flow offered by the orifice is the principal means of developing the heat. Also, the temperature of the air inside the strut rises as the air is compressed.

*1 Strut extension.* The speed of a descending aircraft while landing causes over-compression of the air in the shock strut As a result, the air pressure is greater than that needed to support the static load of the aircraft. The excess pressure tends to extend the shock strut and to bounce the aircraft back into the air. For reasons of comfort and control of the aircraft, this rebound has to be held to the lowest level possible. The most common means of counteracting rebound involves



**Figure 4-171. Complex Shock Strut (Metering Pin)**

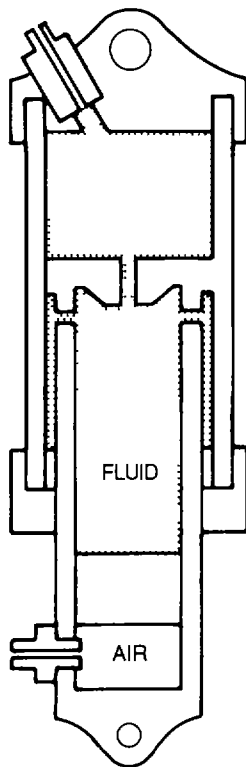
the use of a shock strut annular space. The annular space is a chamber that surrounds the polished piston surface that lies within the cylinder. The annular space has no definite volume. The volume depends on the amount the shock strut is extended or compressed. The annular space is at minimum size when the shock strut is completely extended and at maximum size when the strut is completely compressed. As the shock strut extends, fluid passes from the piston into the annular space.



**Figure 4-172. Complex Shock Strut (Plunger)**

2 *Strut retraction.* Compression of the shock strut forces fluid from the annular space back into the piston. Transfer of fluid into or out of the annular space takes place through transfer passages in the wall of the piston. The fluid moves with some resistance, the resistance varying with the size of the transfer passages. In simple shock struts, the transfer passages are merely holes. In many complex shock struts, the passages are provided with a snubber valve or a rebound control valve. Such a valve allows fluid to flow more





**Figure 4-173. Floating Piston Shock Strut**

freely into the annular space during shock strut compression than it flows out during extension.

**WARNING**

Always be sure to release the air pressure before attempting to remove the air valve core of the air valve assembly. Rock the aircraft and depress the valve core several times with a suitable metal tool to ensure that all pressure is released. Air pressure could blow out the air valve assembly or the valve core when they are loosened, resulting in damage to equipment or injury to personnel.

(4) *Servicing shock struts.* Shock struts should be frequently checked for leakage, proper air pressure, security of attachment, and cleanliness. The exposed portion of the shock strut piston should be

cleaned frequently with a clean, lint-free cloth moistened with hydraulic fluid. Specific instructions for servicing with hydraulic fluid and air pressure are stamped on the nameplate of the shock strut and are given in the applicable aircraft manual. With a few exceptions, a single port in the shock strut serves as a filler hole for both hydraulic fluid and air. An air valve assembly screws into the port.

(5) *Shock strut high-pressure air valve cores.*

The following paragraphs provide general information relative to high-pressure air valve cores (AN809-1) used in hydraulic systems and shock struts.

(a) *Identification.* High-pressure air valve cores may be recognized by the symbol H stamped on the core head

**NOTE**

Some early valve cores incorporated lead plug seats which are now unsatisfactory. Use only valve cores incorporating synthetic rubber plug seats.

1 *Types.* There are two types of valve cores that are approved for all weather high-pressure usage. Sample cores are shown in figure 4-174.

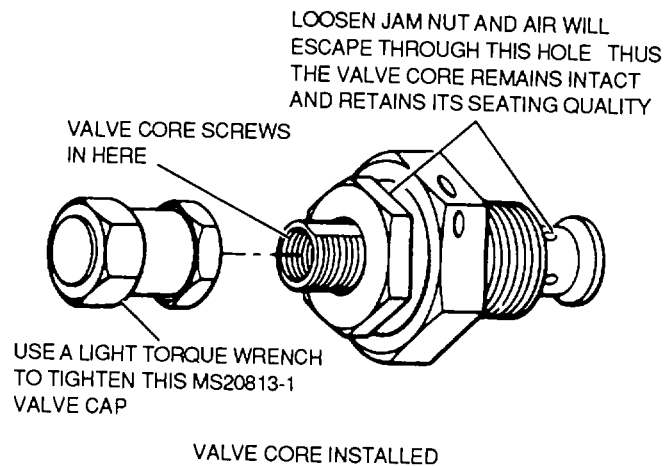
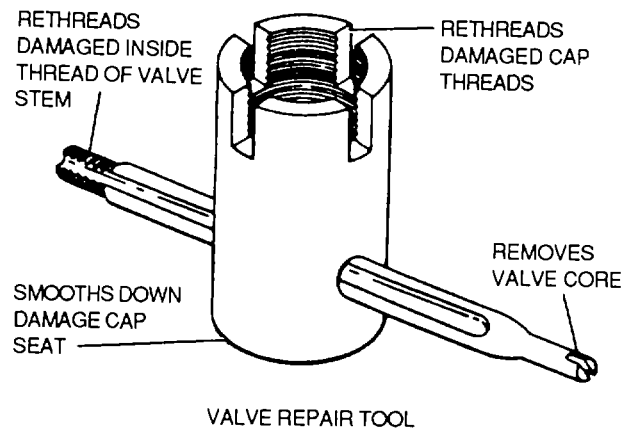
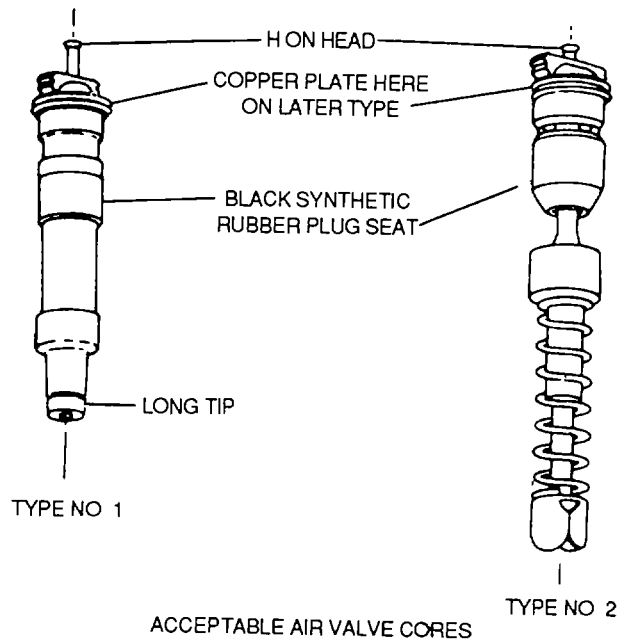
2 *Use.* Air valve cores used in hydraulic systems or shock struts shall be high-pressure type. Low-pressure cores such as used in tires and tubes will not be used in hydraulic installations

(b) *Installation Procedures for Installing high-pressure air valve cores* are described in the following paragraphs.

**NOTE**

Use a drop of hydraulic fluid, MIL-H-5606, on plug seat before installation of valve core in hydraulic installations

1 *Core installation.* Valve cores are installed with valve repair tool, MIL-T-4873, shown in figure 4-174. This tool is also used when it becomes necessary to remove core, smooth down a damaged cap seat, rethread damaged inside thread of valve stem, or rethread damaged cap threads



**Figure 4-174. High-Pressure Air Valve Cores**

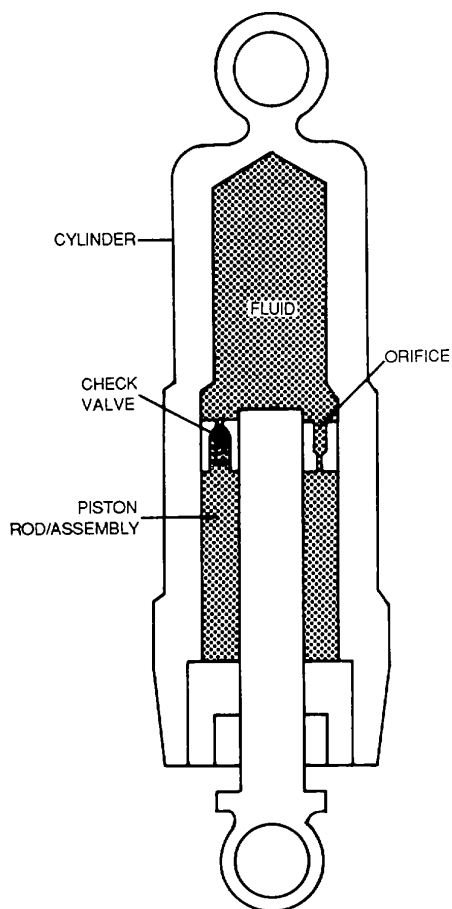
proper type are not available or when aircraft involved is needed for tactical or other urgent use.

**4 Core cap.** Install a low temperature valve core cap, part No. MS20813. These caps are painted yellow for identification as low temperature caps.

**c. Liquid Springs.** The liquid spring contains hydraulic fluid under pressure. The cushioning effect of the spring is produced by effecting a slight compression in the fluid. Note in figure 4-175 that the piston rod fits into the inner space of the cylinder and that a gland seal is provided to prevent fluid leakage as the piston rod moves into and out of the housing. The housing is attached to a stationary part of the aircraft, and the piston rod is connected to a movable part of the landing gear. A typical installation of a liquid spring on a tail landing gear of an Army aircraft is shown in figure 4-176.

**(1) Uses.** The liquid spring performs the same functions as the shock struts just discussed, but there are differences in operation. The manner in which the liquid spring performs these functions is described in the following paragraphs.

**(a) Supporting static loads.** The weight of the parked aircraft tends to move the housing of the liquid spring downward over the piston rod. The inward movement of the piston rod decreases the space occupied by the fluid. This compresses the fluid, thus increasing its pressure. The movement continues until fluid pressure puts a force on the shaft equal to the force tending to move the shaft inward. When this point is reached, no further inward movement of the shaft takes place and the aircraft is held in a stationary position.



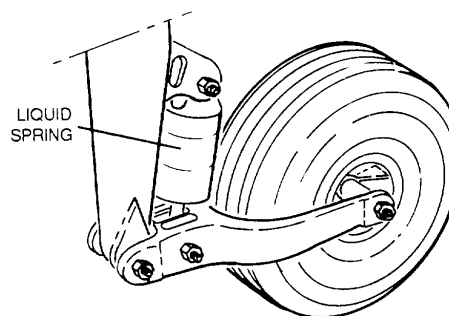
**Figure 4-175. Liquid Spring**

**2 Core removal.** Valve cores shall not be removed from valve body unless it will be replaced with a new core, nor will it be removed or loosened from hydraulic accumulators or shock struts to exhaust pressure and then be reinstalled (figure 4-174).

**NOTE**

In case a core is reinstalled, it shall be seated tightly and examined for leaks.

**3 Core installation.** Valve cores shall not be reinstalled when removed from hydraulic pressure accumulators or shock struts, except when cores of



**Figure 4-176. Tailwheel Liquid Spring**

(b) *Cushioning during taxiing.* The liquid spring controls the bouncing motion of the aircraft in much the same way as the shock strut does. As the piston in the liquid spring moves inward and outward in relation to its housing, there is a back-and-forth movement of fluid through an orifice in the piston. This fluid flow restrains the rate at which the piston moves, thus dampening the up-and-down movements of the aircraft fuselage.

(c) *Reducing shock during landing.* In the liquid spring, the resistance to fluid flow necessary to convert motion energy to heat energy is effected by means of a check valve in the piston. As the liquid spring compresses, fluid flows through the check valve in addition to flowing through the orifice. During extension, the check valve closes and fluid then passes through the orifice only. The additional restraint that is set up to the movement of fluid from one side of the piston to the other provides rebound control during landing.

(2) *Servicing.* The liquid spring can be serviced as follows:

(a) The exposed portion of the liquid spring shaft should be cleaned by using a clean, lint-free cloth moistened with hydraulic fluid.

(b) When the liquid spring is serviced to the correct level with the proper type of hydraulic fluid, the fluid is under pressure. A special gun, which looks like a hand grease gun, is used to force the fluid inside the spring.

#### NOTE

Specific servicing instructions are stamped on the nameplate of the spring and are also included in the manual for the aircraft.

**4-20. Use of Test Stands.** The purpose of the aircraft hydraulic test stand is to perform the following test operations on aircraft hydraulic systems: flush or fill the system with micronically filtered hydraulic fluid, provide a source of hydraulic pressure for testing aircraft hydraulic systems without the necessity of operating the aircraft engine, and test all components of the aircraft hydraulic systems, including aircraft with pressurized reservoir systems. The appropriate aircraft and equipment technical manuals must be consulted prior to use of any test stand. This manual contains only general guidelines for their use.

a. *Safety.* Prior to use of a test stand, it is essential that the personnel responsible for its operation are completely familiar with procedures and operation of the equipment.

#### WARNING

- Always wear ear protection when noise produced by test stand engines exceeds established limits. Failure to comply will result in serious injury to personnel.
- Do not connect or disconnect any hoses with the fluid bypass valve closed and the test stand in operation. High pressure contained in the hose may injure personnel.

b. *Procedures.* General operating procedures are as follows:

(1) Set the parking brake to secure the test stand in position.

(2) Perform the operator inspection of the test stand.

(3) Connect the test stand coupling halves to the corresponding outlets on the aircraft. Keep unused couplings capped at all times.

(4) Open the fluid bypass valve.

(5) Start the engine in accordance with applicable operating procedures.

(6) Adjust the pump delivery for requirements of the aircraft under test.

#### WARNING

Do not connect or disconnect any hoses with the fluid bypass valve closed and the test stand in operation. High pressure contained in the hose may injure personnel.

(7) Slowly close the fluid bypass valve.

(8) Adjust the pressure relief valve to relieve pressure at approximately 200 psi above the system pressure of the system under test.

(9) Open the flow control valves and proceed with the test in accordance with the applicable aircraft technical manual

(10) Following the test procedure, open the bypass valve

(11) Close the flow control valves

(12) Allow the engine to cool as required by the specific operating procedures

(13) Shut down test stand in accordance with applicable operating procedures

(14) Disconnect couplings from aircraft and cap immediately to prevent contamination.

(15) Release parking brake and tow test stand from work area

**4-21. Conversion of Aircraft to Fire-Resistant Hydraulic Fluid.** Following are general guidelines for conversion of Army aircraft from MIL-H-5606 to MIL-H-83282 hydraulic fluid.

a. Hydraulic Fluid MIL-H-5606. MIL-H-5606 is a petroleum base hydraulic fluid and is presently specified for use in some Army rotary wing and fixed wing aircraft. Because of its relatively low flashpoint of 200°F (93°C), it has been considered a safety hazard. In an effort to remove the vulnerability of aircraft systems and related support equipment to accidental or combat-incurred fires, hydraulic fluid MIL-H-83282 has been developed as a directly interchangeable fluid which is significantly less susceptible to fire, with a flashpoint of 400°F (204°C).

b. Hydraulic Fluid MIL-H-83282. MIL-H-83282 consists of a synthetic hydrocarbon base and contains additives which provide superior anti-wear characteristics and inhibit oxidation and corrosion. MIL-H-83282 has an operational high temperature limit of 400°F (204°C) as compared to 275°F (135°C) for MIL-H-5606. These factors should provide significantly improved reliability. Flashpoint, fire point, and spontaneous ignition temperatures of MIL-H-83282 exceed that of MIL-H-5606 by greater than 200°F (93°C),

and tests show that MIL-H-83282 extinguishes itself when the external source of flame or heat is removed. MIL-H-83282 is compatible with all materials used in systems presently employing hydraulic fluid MIL-H-5606 and may be combined with the latter fluid with no adverse effect except a degradation of its fire resistant properties. However, the presence of MIL-H-5606 in amounts exceeding 3 percent by volume will compromise the fire resistant performance of MIL-H-83282. Although MIL-H-83282 exceeds the performance of MIL-H-5606 at normal temperatures, the viscosity of MIL-H-83282 increases at low temperatures, therefore, use of MIL-H-83282 must be within the limitations set forth in paragraph 4-21f.

c. Applications of MIL-H-83282. The fire hazards of MIL-H-5606 are greatest in flight control systems which are under high pressure and which have a relatively large volume of fluid. The aircraft hydraulic systems and components shown in table 4-43 will be converted from MIL-H-5606 to MIL-H-83282.

d. Non-Applicability of MIL-H-83282. The components shown in table 4-44 will retain MIL-H-5606 hydraulic fluid. These components cannot be readily serviced by field personnel or have not been tested for MIL-H-83282. In the event that the temperature limitations in paragraph b above are exceeded, field personnel will be unable to change these components from MIL-H-83282 back to MIL-H-5606.

e. Conversion Procedures. Procedures will be performed at Direct Support or higher levels of maintenance unless otherwise directed by reference to a specific maintenance manual. Refer to the applicable aircraft Technical Manual or to TB 55-1500-334-25 for specific conversion procedures.

f. Operating Temperature Limitations. Although MIL-H-83282 operates well under normal temperatures, the viscosity of the fluid increases as the temperature decreases. Therefore, the minimum ambient operating temperatures shown in table 4-45 have been established for the use of MIL-H-83282. These temperatures are based on a cold soak of the hydraulic fluid at low temperatures. Aircraft that are sheltered or pre-heated prior to engine start should not have any problems with stiff or sluggish flight controls. Unless the sheltered areas are at or below the temperatures in table 4-45, the viscosity of MIL-H-83282 will not create any difficulty. Once the aircraft is started and warm, the hydraulic fluid should stabilize within normal operating limits.

**Table 4-43. Applications of MIL-H-83282**

<b>Aircraft</b>	<b>Application</b>
OH-58A	Flight Control System
UH-1/H	Flight Control System Armament System M6 Additional Armament Systems for UH-1 B, M16 and M21
UH-1/M	Hydraulic Systems 1 and 2 Armament Systems M6, 16, 21
AH-1 Series	Hydraulic Systems 1 and 2 Armament Turret System
CH-47 C/D	Flight Control Systems 1 and 2 Utility Hydraulic System
OV-1	Main Hydraulic System  UH-60A Hydraulic Systems 1, 2, and 3
<b>Servicing Equipment</b>	
MK-1 D6, MSU-1 AGPU	Hydraulic dispensers and test stands will be converted to MIL-H-83282 to provide ground support to converted aircraft.

**Table 4-44. Non-Applicability of MIL-H-83282**

Aircraft	Application
Aircraft	Component
UH-1/H/M	Stabilizer Bar Dampers
AH-1 Series	Pylon Dampers
CH-47 C/D	Lag Dampers Landing Gear Shock Struts
OV-1	Propellor Control System and Landing Gear Pneudraulic Struts
OH-6 UH-60A	Landing Gear Struts
AH-64A	Landing Gear Shock Struts Brake System

**Table 4-45. Operating Temperature Limitations of MIL-H-83282**

Aircraft	Minimum temperature
UH-1	-30°F (-35°C)
OH-58	-25°F (-32°C)
CH-47	-50°F (-46°C)
OV-1	-40°F (-40°C)
AH-1	-50°F (-46°C)
AH-64	-25°F (-32°C)
UH-60A	-40°F (-40°C)
	<b>Servicing Equipment</b>
D5A, D5B, D6	-20°F (-29 °C)
MSU-1	-25°F (-29°C)

## APPENDIX A

### REFERENCES

---

#### A-1. ARMY REGULATIONS (AR):

AR 385-10	The Army Safety Program
AR 385-30	Safety Color Code Markings and Signs
AR 385-32	Protective Clothing and Equipment

#### A-2. CATALOGUING HANDBOOK:

H4/H8	Commercial and Government Entity (CAGE)- Name to CAGE
-------	--

#### A-3 FIELD MANUALS (FM):

FM1-509	Fundamentals of Aircraft Pneudraulics
FM10-69	Petroleum Supply Point Equipment and Operations

#### A-4 TECHNICAL BULLETINS (TB)

55-1500-334-25	Conversion of Aircraft to Fire-Resistant Hydraulic Fluid
----------------	--

#### A-5 TECHNICAL MANUALS (TM)

TM55-1510 Series	Operator's, direct support, general support and depot maintenance manuals (fixed wing)
------------------	---

TM55-1520 Series	Operator's, direct support, general support, and depot maintenance manuals (rotary wing)
------------------	---

#### A-6. NAVY RATE TRAINING MANUAL

NAVPERS 16193	Basic Hydraulics
---------------	------------------

#### A-7. OTHER PUBLICATIONS.

Industrial Hydraulics Manual, Vickers Inc, Troy, Michigan



## GLOSSARY

---

AC (AIR CORPS)-	Flared tube fittings. Now obsolete.
AN (ARMY-NAVY) -	Flared tube fittings
AXIAL-	Pertaining to an axis, commonly refers to flow of fluid or air through a component parallel to that component's lengthwise axis.
BOURDON TUBE -	Tube in an instrument that tends to straighten when fluid or air pressure acts upon it, thereby acting on an indicating needle.
BUNA N -	Synthetic rubber compound with excellent resistance to petroleum products; used as material for flexible hose.
CHAMFER -	A beveled edge.
COLD FLOW -	Deep, permanent impressions in flexible hose produced by pressure from hose clamps or supports.
FIRE POINT -	Temperature at which fluid gives off vapor in sufficient quantity to ignite and continue to burn when exposed to a spark or flame.
FLASH POINT -	Temperature at which fluid gives off vapor in sufficient quantity to ignite momentarily or flash when exposed to a spark of flame.
GASKET-	Hydraulic seal used In applications where there is no relative motion.
MICRON -	0000394 inch or 1/1000th millimeter.
MONEL-	High-strength nickel steel used for rivets and other materials used in high-heat applications.
MS (MILITARY STANDARD) -	Designation of certain materials used in aircraft maintenance.
PACKING -	Hydraulic seal used in areas of relative motion.
PERMASWAGE -	Repair technique for permanent installation of fittings squeezed onto hydraulic tubing under very high pressure.
PHENOLIC -	Cotton fabric filled with a phenolic resin to form a hard material suitable for fairleads, supports, etc.
SAE (SOCIETY OF AUTOMOTIVE ENGINEERS) -	Standards for thread sizes, metal identification numbers, etc.

## **GLOSSARY-CONT**

---

SOLENOID -	Switch using an electromagnetic field to hold it in one position.
SWAGING -	Process of installing a fitting on tubing by squeezing it under very high pressure.
TETRAFLUOROETHYLENE -	Compound commonly known as Teflon used in flexible hose, back-up rings, gaskets, etc.
VISCOSITY -	A fluid's internal resistance to flow.

**INDEX**

<b>Subject</b>	<b>Paragraph, Figure, Table Number</b>
<b>A</b>	
Absorbing Units, Dampening and .....	4-19
Acceptable and Unacceptable Tube Bends .....	F4-5
Accumulator, Cylindrical .....	F4-118
Accumulator, Operation .....	4-1 5b
Accumulator, Spherical .....	F4-119
Accumulators .....	4-15
Accumulator Operation .....	4-15b
Maintenance .....	4-15c
Types .....	4-15a
Actuating Cylinder, Double-Action (Extension) .....	F4-134
Actuating Cylinder, Double-Action (Retraction) .....	F4-135
Actuating Cylinder, Single-Action .....	F4-133
Actuating Cylinders (Actuators) .....	4-16g
Actuators, Troubleshooting .....	T4-42
Adjuster Valve, Brake .....	F4-157
After Swage Dimensions .....	F4-86
Air Cylinder, Spherical .....	F4-95
Air Cylinders, Hydraulic Reservoirs .....	4-11h
Air Filters .....	4-12e
Air Valve Cores, High-Pressure .....	F4-174
Aircraft Brake Systems .....	4-18
Brake Deboosters .....	4-18c
Helicopter Rotor Brake Systems .....	4-18d
Maintenance of Brake Systems .....	4-18e
Wheel Brake Assemblies .....	4-18b
Wheel Brake Systems .....	4-18a
Alignment, Tube and Fitting .....	F4-14
Alignment, Tubing .....	F4-20
Aluminum Protective Dust Plug and Moisture Seal .....	F4-54
AN Flared Fitting Identification .....	T4-9
Application of Mechanical Advantage .....	F2-5
Application of Swaged Tubing Repairs .....	4-9a
Applications of MIL-H-83282 .....	4-21 c, T4-43
Aromatic And Heat-Resistant Hose, MIL-H-6000 .....	F4-35
Aromatic, Flame, and Oil-Resistant Hose, MIL-H-7938 .....	F4-36
Aromatic-Resistant Hose, Flame and MIL-H-8794 .....	F4-34
Aromatic-Resistant Hose, Nonsel-Sealing, MIL-H-5593 .....	F4-37
Aromatic-Resistant Hose, Self-Sealing, MIL-H-7061 .....	F4-38
Assembly Clearance, Nipple .....	F4-47
Assembly of High-Pressure Tetrafluoroethylene (Teflon) Hose Assemblies .....	4-5j
Assembly of Medium-and Low-Pressure Hose Assemblies .....	F4-43
Assembly of Medium-Pressure Tetrafluoroethylene (Teflon) Hose Assemblies .....	4-5i
Assembly Surface, Nipple .....	F4-46

**INDEX - CONT**

<b>Subject</b>	<b>Paragraph, Figure, Table Number</b>
<b>A - Continued</b>	
Assembly, V-Ring Packings in Various Positions of .....	F4-71
<b>B</b>	
Backup Ring Installation, Double .....	F4-76
Backup Ring Installation, Single .....	F4-75
Backup Ring, Teflon, Installing .....	F4-73
Backup Ring, Teflon, Reversing Spiral of .....	F4-74
Backup Ring, Teflon, Stretching .....	F4-72
Backup Rings .....	4-8
Identification .....	4-8a
Installation .....	4-8b
Backup Rings, Leather, Installation of .....	F4-77
Baffles and Fins .....	4-11c
Baffles, Fins, and Finger Strainer, Reservoir with .....	F4-91
Ball Size, Inspection, Chart .....	T4-13
Band Identification, Solid Color .....	F4-2
Band Location, Tube Insertion .....	T4-37
Basic Swage Tool Assembly Showing Lower Die Block Assembly and Position of Fitting Locator .....	F4-84
Bead Dimensions .....	F4-13
Beaded Tubing Joints .....	4-2h
Beading Large Tubing .....	F4-11
Bend Radii for Conduit and Fluid Lines .....	T4-1
Bend Radii of Hose for Fuel, Oil, and Coolant Systems .....	T4-32
Bending Machine, Bending Tube with .....	F4-4
Bending Tube with Bending Machine .....	F4-4
Bending Tubing .....	4-2e
Bends, Installation of Flexible Hose .....	4-2c
Bent-Axis Constant-Volume Pump .....	F4-101
Bleeding Brake Hydraulic System .....	F4-160
Blocked Flowing Hydraulic Fuse .....	F4-142
Boss Installation, Torque Valves for .....	T4-7
Brake Assembly, Disc .....	F4-151
Brake Assembly, Disc, Cross Section .....	F4-152
Brake Bleeding, Gravity Method for .....	F4-161
Brake Hydraulic System, Bleeding .....	F4-160
Brake System, Rotor Blade .....	F4-159
Brake Systems, Aircraft .....	4-18
Bulge, Coupling, Low-and Medium-Pressure Hose Assemblies .....	F4-44
Bulge, Coupling, MIL-H-7061 Hose Assembly .....	T4-30
Bulkhead and Universal Fitting Assembly, Combination .....	T4-27

**INDEX - CONT**

<b>Subject</b>	<b>Paragraph, Figure, Table Number</b>
<b>C</b>	
Chafing, Installation of Flexible Hose .....	4-6f
Check Valve, Orifice .....	F4-128
Check Valve, Simple .....	F4-127
Check Valves .....	4-16c
Checking Swaged Joint with D9892 Inspection Gauge .....	F4-85
Chipless Cutter .....	F4-81
Clamp Sizes, Support (For Use with MIL-H-38360 Hose of Teflon) .....	T4-29
Cleaning (of 55-Gallon Drums) .....	3-3b
Cleaning Tubing .....	4-2b
Clogged Filters in Differential Pressure Indicator .....	F4-100
Clogged Fluid Filter .....	F4-98
Closed Center Hydraulic System .....	4-17b
Combination Bulkhead and Universal Fitting Assembly .....	F4-27
Complex Shock Strut (Metering Pin) .....	F4-171
Complex Shock Strut (Plunger) .....	F4-172
Components, MS Fitting and .....	F4-17
Compound Master Cylinder .....	F4-149
Computation of Force, Area, and Pressure .....	2-1b
Computation of Volume, Area, and Length of Stroke .....	2-1c
Computing Force, Pressure, and Area .....	F2-1
Computing Volume, Length, and Area .....	F2-2
Conduit and Fluid Lines, Bend Radii for .....	T4-1
Connections, Tubing-to-Tubing .....	F4-22
Constant-Volume Pump, Bent-Axis .....	F4-101
Constant Volume Pump Foot Valve .....	F4-104
Constant Volume Pump (Piston Installation) .....	F4-102
Constant Volume Pump (Piston Operation) .....	F4-103
Consumable Materials .....	1-3
Contamination, Fluid .....	2-4
Contamination Prevention .....	2-4c
Control Units, Flow .....	4-16
Control Valve, Power Brake (Brake Applied) .....	F4-152
Control Valve, Power Brake (Brake Released) .....	F4-153
Control Valve, Solenoid-Actuated (De-energized) .....	F4-126
Control Valve, Solenoid-Actuated (Energized) .....	F4-125
Control Valves .....	4-16b
Conversion of Aircraft to Fire-Resistant Hydraulic Fluid .....	4-21
Applications of MIL-H-83282 .....	4-21c
Conversion Procedures .....	4-21e
Hydraulic Fluid MIL-H-5606 .....	4-21a
Hydraulic Fluid MIL-H-83282 .....	4-21b
Non-Applicability of MIL-H-83282 .....	4-21d
Operating Temperature Limitations .....	4-21f
Conversion Procedures (MIL-H-5606 to MIL-H-83282) .....	4-21e
Coupling Bulge, Low-and Medium-Pressure Hose Assemblies .....	F4-44
Coupling Bulge, MIL-H-7061 Hose Assembly .....	T4-30

**INDEX - CONT**

<b>Subject</b>	<b>Paragraph, Figure, Table Number</b>
----------------	--

**C - Continued**

Couplings, Quick-Disconnect .....	4-10
Cross Section, Piston Damper .....	F4-163
Cross Section, Vane Damper .....	F4-168
Cutoff Factor, MIL-H-8788 or MIL-H-8790 (in Inches) .....	T4-15
Cutoff Factors, MIL-H-38360 Hose (in Inches) .....	T4-27
Cutoff Factors, Teflon Hose (in Inches) .....	T4-22
Cutter, Chipless .....	F4-81
Cutting Flexible Hose, Knife for .....	F4-39
Cutting, Marking Tube Prior to .....	F4-46
Cutting, Tube with Tube Cutter .....	F4-3
Cutting Tubing .....	4-2d

**D**

Damaged Fittings .....	F4-29
Dampening and Absorbing Units .....	4-19
Hydraulic Damper .....	4-19a
Liquid Springs .....	4-19c, F4-174
Shock Struts .....	4-19b
Damper, Piston .....	F4-162
Damper, Vane .....	F4-166
Data Drawing, Tube Bend .....	F4-6
Detecting Fluid Contamination .....	2-4a
Determining Hose Assembly Length .....	F4-40
Determining Tube Thickness and Burst Pressure .....	T4-11
Devices for Regulating Pressure .....	4-14
Pressure Gauges .....	4-14a
Pressure Reducing Valves .....	4-14d
Pressure Relief Valves .....	4-14c
Pressure Switches .....	4-14b
Differential Pressure Indicator (Clogged Filters) .....	F4-99
Differential Pressure Indicator (Normal Flow) .....	F4-100
Dimensions, After Swage .....	F4-86
Dimensions, Beading .....	F4-13
Dimensions for Double-Flared Tubing .....	F4-8
Dimensions for Single-Flared Tubing .....	F4-7
Disc Brake' Assembly .....	F4-154
Disc Brake Assembly Cross Section .....	F4-155
Distance Between Supports for Fluid Tubing, Maximum .....	T4-12
Double Backup Ring Installation .....	F4-76
Double Lap Flare, Tubing with .....	F4-11
Double-Action Actuating Cylinder (Extension) .....	F4-134
Double-Action Actuating Cylinder (Retraction) .....	F4-135

**INDEX - CONT**

<b>Subject</b>	<b>Paragraph, Figure, Table Number</b>
<b>D - Continued</b>	
Double-Action Hand Pump .....	F4-111
Double-Flared Tubing, Dimensions for .....	F4-8
Dual Internal O-Ring Removal .....	F4-64
Dual Parking Brake Valve .....	F4-156
Dual Parking Brake Valve (Off) .....	F4-157
Dual Parking Brake Valve (On) .....	F4-158
Dust Cap (AN-SAE Friction), Plastic Protective .....	F4-56
Dust Cap, Plastic Protective .....	F4-55
Dust Cap, Steel Protective .....	F4-53
Dust Plug and Moisture Seal, Aluminum Protective .....	F4-54
Dust Plug and Moisture Seal (AN-SAE Threaded) Plastic Protective .....	F4-51
Dust Plug and Moisture Seal, Steel Protective .....	F4-52
<b>E</b>	
Ease of Installation (of Hydraulic Systems) .....	2-2c
Ease of Operation (of Hydraulic Systems) .....	2-2b
Efficiency (of Hydraulic Systems) .....	2-2a
Elliptical Rings .....	4-7b, F4-70
External O-Ring Installation .....	F4-69
External O-Ring Removal (Spoon-Type Tools) .....	F4-65
External O-Ring Removal (Wedge-Type Tools) .....	F4-66
<b>F</b>	
Failure Modes and Recommended (Permaswage) Repair Methods .....	F4-79
Field Assembly of High Pressure Teflon Hose, MIL-H-38360 .....	F4-50
Field Disassembly of Teflon Hose .....	F4-45
Field Fabrication of High-Pressure Hose Assemblies .....	F4-41
Filter Element Bypass Valve, Hydraulic Reservoirs .....	4-11f
Filter Elements, Hydraulic Reservoirs .....	4-11e
Filter Elements, Hydraulic Systems Filters .....	4-12c
Filter Elements, Reservoir with .....	F4-94
Filter, Fluid, Assembly .....	F4-96
Filters, Hydraulic System .....	4-12
Finger Strainers, Hydraulic Reservoirs .....	4-11d
Fingertight-Plus Turns Methods, Hose Clamp Tightening .....	T4-10
Fingertight-Plus Turns Methods, Hose Clamp Tightening, Beaded Tubing .....	F4-3
Fitting Dimensions After Swaging .....	T4-39
Fittings .....	4-3
Flared Fittings .....	4-3g
Flareless Fittings .....	4-3a
Oxygen System Tapered Pipe Thread .....	4-3b

**INDEX - CONT**

<b>Subject</b>	<b>Paragraph, Figure, Table Number</b>
<b>F - Continued</b>	
Rosan Fluid Fittings .....	4-3f
Straight Pipe Thread .....	4-3c
Universal Fittings AN 832, AN 833, and AN 834, High Pressure .....	4-3e
Universal Fittings AN 832, AN 833, and AN 834, Low Pressure .....	4-3d
Fittings, Damaged .....	F4-29
Fittings, Tubing .....	F4-15
Flame and Aromatic Resistant Hose, MIL-H-8794 .....	F4-34
Flame, Aromatic, and Oil-Resistant Hose, MIL-H-7938 .....	F4-36
Flared Fitting Identification, AN .....	T4-9
Flared Fittings .....	4-3g
Flareless Fitting Installation, Bulkhead .....	F4-24, T4-4
Flareless Fittings .....	4-3a
Flareless Fittings, MS .....	F4-18
Flaring Tubing .....	4-2f
Flexible Hose Assemblies	
Assembly of High-Pressure Tetrafluoroethylene (Teflon) Hose Assemblies .....	4-5j
Assembly of Medium-Pressure Tetrafluoroethylene (Teflon) Hose Assemblies .....	4-5i
Identification of Flexible Hose .....	4-5a
Identification Tags for Field Fabricated Hose Assemblies .....	4-5g, F4-42
Instructions for Assembly of High-Pressure (3000 psi) Hose Assemblies MS28759 and MS28762 .....	4-5e
Instructions for Assembly of Medium-Pressure, MS28741, and Low-Pressure, AN6270, Hose Assemblies .....	4-5h
Instructions for Repair of Flexible Rubber Hose .....	4-5d
Proof Testing of Flexible Hose Assemblies .....	4-5f
Replacement of Flexible Hose .....	4-5c
Self-Sealing Hose for Aromatic Fuel, MIL-H-7061 .....	4-5k
Storage of Hose and Hose Assemblies .....	4-5b
Use of Dust Plugs, Dust Caps, and Moisture Seals .....	4-5l
Flexible Hose, Installation of .....	4-6
Floating Piston Shock Strut .....	F4-173
Floating Piston Shuttle Valve .....	F4-132
Flow Control Units .....	4-16
Actuating Cylinders (Actuators) .....	4-16g
Check Valves .....	4-16c
Control Valves .....	4-16b
Hydraulic Fuses .....	4-16k
Hydraulic Servos .....	4-16i, F4-138
Irreversible Valves .....	4-16j, F4-139
Maintenance of Hydraulic Flow Control Units .....	4-16l
Priority Valves .....	4-16e
Ratchet Valve .....	4-16h
Selector Valves .....	4-16a
Sequence Valves .....	4-16d



**INDEX - CONT**

<b>Subject</b>	<b>Paragraph, Figure, Table Number</b>
----------------	--

**F - Continued**

Shuttle Valves .....	4-16f
Fluid Contamination .....	2-4
Contamination Prevention .....	2-4c
Detecting Fluid Contamination .....	2-4a
System Flushing .....	2-4b
Fluid Dispenser, Hydraulic .....	F3-6
Fluid Filter Assembly .....	F4-96
Fluid Filter (Clogged) .....	F4-98
Fluid Filter (Normal Flow) .....	F4-97
Fluid-Pressurized Reservoir (Pressurized) .....	F4-93
Fluid-Pressurized Reservoir (Unpressurized) .....	F4-92
Full Flow in Hydraulic Fuse .....	F4-141
Fuse Assembly, Hydraulic .....	F4-140

**G**

Gasket Installation, MS Fitting .....	F4-19
Gauge, Pressure .....	F4-114
General Hydraulic Maintenance Practices .....	4-1
General Shop Rules (Hydraulic Shop) .....	3-1
Responsibility .....	3-1a
Shop Housekeeping .....	3-1b
Shop Safety .....	3-1d
Shop Tools and Materials .....	3-1c
Gravity Method for Brake Bleeding .....	F4-161

**H**

Hand Pump Test Circuit .....	F4-112
Hand Pumps .....	4-13c
Handling of Hydraulic Fluid in 55-Gallon Drums .....	3-3
Cleaning .....	3-3b
Storage .....	3-3a
Transporting Fluid to Aircraft .....	3-3d
Withdrawing Fluid from Drum .....	3-3c
Helicopter Rotor Brake Systems .....	4-18d
High-Pressure Air Valve Cores .....	F4-174
High-Pressure Hose Assemblies, Field Fabrication of .....	F4-41
High-Pressure Teflon Hose, MIL-H-38360, Field Assembly of .....	F4-50
High-Pressure Tubing, Repairing .....	F4-33
Hose Assemblies, Flexible .....	4-5
Hose Assembly Length, Determining.....	F4-42
Hose Clamp, in Installation of Flexible Hose .....	4-6i
Hose Clamp Tightening, Fingertight-Plus Turns Method.....	T4-10
Hose Clamp Tightening, Fingertight-Plus Turns Method, Beaded Tubing .....	T4-3
Hose Clamp, Tightening, With Socket .....	F4-32

**INDEX - CONT**

<b>Subject</b>	<b>Paragraph, Figure, Table Number</b>
<b>H - Continued</b>	
Hose Connections to Engines, Installation of Flexible Hose .....	4-6h
Hose Cutoff Factor, MIL-H-8788 or MIL-H-8790 Hose (in Inches) .....	T4-14
Hose Cutoff Factors, MIL-H-38360 Hose (in Inches) .....	T4-27
Hose End Fitting and Coupling Nut Installation Torque in Inch-Pounds .....	T4-34
Hose Installation, Flexible Hose .....	4-5b
Hose Line Installation Aids for All Types of Hoses .....	F4-57
Hose Markings, and Installation of Flexible Hose .....	4-6j
Hose, MIL-F-27272, Tetrafluoroethylene (in Inches) .....	T4-21
Hose, MIL-H-38360, Tetrafluoroethylene (in Inches) .....	T4-27
Hose Restrictions, Installation of Flexible Hose .....	4-6d
Hydraulic Dampers.....	4-19a
Hydraulic Filler and Bleeder Unit .....	3-2a
Hydraulic Fluid (Fire Resistant), Conversion of Aircraft to .....	4-21
Hydraulic Fluid in Army Aircraft, Types .....	2-3
Hydraulic Fluid in 55-Gallon Drums, Handling of .....	3-3
Hydraulic Fluid MIL-H-5606 .....	4-21a
Hydraulic Fluid MIL-H-83282 .....	4-21b
Hydraulic Fuse Assembly .....	F4-140
Hydraulic Fuse (Blocked Flow) .....	F4-142
Hydraulic Fuse (Full Flow) .....	F4-141
Hydraulic Hose Testing Unit .....	3-2d
Hydraulic Hose Testing Unit, Typical .....	F3-3
Hydraulic Maintenance Practices, General .....	4-1
Hydraulic Motor .....	F4-113
Hydraulic Motors .....	4-13d
Hydraulic Packings and O-Rings .....	4-7
Elliptical Rings .....	4-7b, F4-70
O-Rings .....	4-7a
V-Ring Packings .....	4-7c
Hydraulic Reservoirs .....	4-11
Air Cylinders .....	4-11h
Baffles and Fins .....	4-11c
Filter Element Bypass Valve .....	4-11f
Filter Elements .....	4-11e
Finger Strainers .....	4-11d
Maintenance of Reservoirs .....	4-11i
Standpipes .....	4-11g
Theory of Operation .....	4-11b
Types of Hydraulic Reservoirs Used in Hydraulic Systems .....	4-11a
Hydraulic Servos .....	4-16i, F4-138
Hydraulic System Filler and Bleeder, Typical .....	F3-1
Hydraulic System Filters .....	4-12
Air Filters .....	4-12e
Filter Elements .....	4-12c
Servicing Filters .....	4-12f
Theory of Operation .....	4-12b

**INDEX - CONT**

<b>Subject</b>	<b>Paragraph, Figure, Table Number</b>
<b>H - Continued</b>	
Two-Stage Fluid Filters .....	4-12d
Uses of Filters in Hydraulic Systems .....	4-12a
Hydraulic System, Open-Center (Valve Closed) .....	F4-143
Hydraulic System, Open-Center (Valve Open) .....	F4-144
Hydraulic Systems in Army Aircraft, Use of .....	2-2
Hydraulic Test Stand, Fixed .....	3-2b
Hydraulic Test Stand, Portable, Gasoline Engine-Driven .....	3-2c
Hydraulic Test Stand, Typical Gasoline Engine-Driven .....	F3-2
<b>I</b>	
Identification of Backup Rings .....	4-8a
Identification of Flexible Hose .....	4-5a
Identification of O-Rings .....	F4-63
Identification Tags for Field Fabricated Hose Assemblies .....	4-5g, F4-42
Identification Tape, Printed-Symbol .....	F4-1
In-Line Cam-Operated Selector Valve (Actuator Extending) .....	F4-123
In-Line Cam-Operated Selector Valve (Actuator Retracting) .....	F4-122
Inspection	
of Quick Disconnect Coupling .....	4-10b
of Swaged Joint .....	4-9g
Inspection Ball Size Chart .....	T4-13
Inspection Checking (of Swaging), Troubleshooting Guide for .....	T4-38
Installation	
Hose .....	4-6b
of Backup Rings .....	4-8b
of Beaded Tubing .....	4-2j
of Flared Tubing .....	4-2i
of Flexible Hose .....	4-6
of Quick-Disconnect Couplings .....	4-10a
Installation Aids, Hose Line, for all Types of Hose .....	F4-57
Installation of Flexible Hose .....	4-6
Bends .....	4-6c
Chafing .....	4-6f
Hose Clamp .....	4-6i
Hose Connections to Engines .....	4-6h
Hose Installation .....	4-6b
Hose Markings .....	4-6j
Hose Restrictions .....	4-6d
Lubrication .....	4-6a
MS Flared Swivel Connections Torquing .....	4-6k
Support .....	4-6e
Temperature Protection .....	4-6g
Installation of Leather Backup Rings .....	F4-77
Installation of MS33514 Fitting End .....	F4-25

**INDEX - CONT**

<b>Subject</b>	<b>Paragraph, Figure, Table Number</b>
<b>I - Continued</b>	
Installation Procedures, Teflon Hose, Right and Wrong .....	F4-49
Installation Torque Values MS Flared Swivel .....	F4-25
Installation Torque Values MS Flared Swivel Nut Fittings (Reference AND100064) .....	T4-33
Installed Low-Pressure Hose .....	F4-16
Installing Teflon Backup Ring .....	F4-73
Instructions	
for Assembly of High Pressure (3000 psi) Hose Assemblies	
MS28759 and MS28762 .....	4-5e
for Assembly of Medium-Pressure, MS28741, and	
Low-Pressure, AN6270, Hose Assemblies .....	4-5h
for Repair of Flexible Rubber Hose .....	4-5d
Internal O-Ring Installation (Metallic Sleeve).....	F4-68
Internal O-Ring Installation (Paper Cover).....	F4-67
Internal O-Ring Removal (Pull-Type Extractor) .....	F4-61
Internal O-Ring Removal (Push-Type Extractor) .....	F4-63
Internal O-Ring Removal (Wedge-Type Extractor) .....	F4-62
Introduction	
Consumable Materials .....	1-3
Purpose .....	1-1
Scope .....	1-2
Irreversible Valves .....	4-16j, F4-139
<b>J</b>	
Jamnut (AN924) Used on Fittings, Torque Values for .....	T4-8
<b>K</b>	
Kellogg Stroke Reduction Pump Assembly.....	F4-109
Kellogg Stroke Reduction Pump (Reduced Output) .....	F4-110
Knife for Cutting Flexible Hose.....	F4-39
<b>L</b>	
Landing Gear System Using Mechanically Actuated Sequence Valves .....	F4-129
Large Tubing, Beading .....	F4-12
Liquid Spring, Tailwheel .....	F4-176
Liquid Springs .....	4-19c, F4-175
Low-Pressure Hose, Installed .....	F4-16
Low-Pressure Tubing, Repair of .....	F4-30
Low-Pressure Tubing Repair, Tubing End Clearance for .....	F4-31
Lubricant Selection, Packing and .....	T4-6

**INDEX - CONT**

<b>Subject</b>	<b>Paragraph, Figure, Table Number</b>
----------------	--

**L - Continued**

Lubrication (during Installation of Flexible Hose) .....	4-6a
Lubrication (of Hydraulic Systems) .....	2-2e

**M**

Main Rotor Assembly with Piston Dampers .....	F4-168
Maintenance of Accumulators .....	4-15c
Maintenance of Brake Systems .....	4-18e
Maintenance of Power Pumps .....	4-13b
Maintenance of Reservoirs .....	4-11i
Maintenance of Shop Equipment .....	3-2
Hydraulic Filler and Bleeder Unit .....	3-2a
Hydraulic Hose Testing Unit .....	3-2d
Hydraulic Test Stand, Fixed .....	3-2b
Hydraulic Test Stand, Portable, Gasoline Engine-Driven .....	3-2c
Master Gauge Unit .....	3-2f
Tube Bending Machine, Hand-Operated .....	3-2e
Marking MS Fittings .....	F4-23
Marking, Tube End .....	F4-83
Marking with Permaswage Marking Tool, D9862-S, M, and L .....	F4-82
Master Cylinder, Compound .....	F4-149
Master Cylinder, Power-Boost (Brake Applied) .....	F4-150
Master Cylinder, Power-Boost (Brake Released) .....	F4-151
Master Cylinder, Simple .....	F4-148
Master Gauge Unit .....	3-2f
Master Gauge Unit, Typical .....	F3-5
Maximum Distance Between Supports for Fluid Tubing .....	T4-12
Mechanical Advantage .....	2-1e, F2-4
Mechanical Advantage, Application of .....	F2-5
Medium-and Low-Pressure Hose Assemblies, Assembly of .....	F4-45
Medium-Pressure Teflon Hose Assembly Procedure .....	F4-48
MIL-H-83282, Applications of .....	F4-43
MIL-H-83282, Non-Applicability of .....	4-21d, T4-44
MIL-H-83282, Operating Temperature Limitations of .....	T4-45
Minimum Bend Radii of Hose for Fuel Oil, and Coolant Systems .....	T4-32
Motor, Hydraulic .....	F4-113
Motors, Pumps and .....	4-13
MS Fitting and Components .....	F4-17
MS Fitting Gasket Installation .....	F4-19
MS Fittings, Marking .....	F4-23
MS Flared Swivel Connectors Torquing, and Installation of Flexible Hose .....	4-6k
MS Flareless Fittings .....	F4-18
MS Turns and Torque Valves .....	F4-21
MS21921 Coupling Nut, Torque Values for .....	T4-5
MS33514 Fitting End, Installation of .....	F4-25

**INDEX - CONT**

<b>Subject</b>	<b>Paragraph, Figure, Table Number</b>
<b>N</b>	
Nipple Assembly Clearance .....	F4-47
Nipple Assembly Surface .....	F4-46
Non-Applicability of MIL-H-83282 .....	4-21 d, T4-44
Nonself-Sealing, Aromatic and Heat-Resistant Hose, MIL-H-6000 .....	F4-35
Nonself-Sealing, Aromatic-Resistant Hose, MIL-H-5593 .....	F4-37
Normal Flow in Differential Pressure Indicator .....	F4-99
Normal Flow in Fluid Filter .....	F4-97
Nose Landing Gear with Piston Damper .....	F4-164
Nose Landing Gear with Vane Damper .....	F4-168
Nut Installation Torque in Inch-Pounds, Hose End Fitting and Coupling .....	T4-34
<b>O</b>	
O-Ring Identification .....	F4-59
O-Ring Installation, External .....	F4-69
O-Ring Installation, Internal (Metallic Sleeve) .....	F4-68
O-Ring Installation, Internal (Paper Cover) .....	F4-69
O-Ring, Removal of .....	F4-60
O-Ring Removal, Dual Internal .....	F4-64
O-Ring Removal, External (Spoon-Type Extractor) .....	F4-65
O-Ring Removal, External (Wedge-Type Extractor) .....	F4-66
O-Ring Removal, Internal (Pull-Type Extractor) .....	F4-61
O-Ring Removal, Internal (Push-Type Extractor) .....	F4-63
O-Ring Removal, Internal (Wedge-Type Extractor) .....	F4-62
O-Rings .....	4-7a
Open-Center Hydraulic System (Value Closed) .....	F4-143
Open-Center Hydraulic System (Value Open) .....	F4-144
Operating Pressure (psi) for MIL-H-7061, Proof Test and .....	T4-31
Operating, 'Proof, and Burst Test Pressures for AN6270 Hose Assembly using MIL-H-5593 Low Pressure Hose .....	T4-19
Operating, Proof, and Burst Test Pressures for MIL-H-83796 Medium Pressure Hose Assembly, Lightweight .....	T4-17
Operating, Proof, and Burst Test Pressures for MIL-H-83797 Medium Pressure Hose .....	T4-18
Operating, Proof, and Burst Test Pressures for MS28741 Medium Pressure Hose Assemblies, using Single Wire Braid Hose, Military Specification MIL-H-8794 .....	T4-16
Operating, Proof, and Burst Test Pressures for MS28759 and MS28762 Hose Assemblies using MIL-H-8788 High Pressure Hose .....	T4-15
Operating Temperature Limitations (of Hydraulic Fluid) .....	4-21f
Operating Temperature Limitations of MIL-H-83282 .....	T4-45
Orifice Check Valve .....	F4-128
Oxygen System Tapered Pipe Thread .....	4-3b
<b>P</b>	
Packing and Lubricant Selection .....	T4-6

**INDEX - CONT**

<b>Subject</b>	<b>Paragraph, Figure, Table Number</b>
<b>P - Continued</b>	
Packings and O-Rings, Hydraulic .....	4-7
Parking Brake Valve, Dual .....	F4-156
Parking Brake Valve, Dual (Off) .....	F4-157
Parking Brake Valve, Dual (On) .....	F4-158
Pascal's Law .....	2-1d, F2-3
Permaswage Fittings, Typical Styles of .....	F4-78
Permaswage Marking Tool, D9862-S, M, and L, Marking with .....	F4-82
Permaswage Repair with D10000 Series Tooling-Tube Material and Maximum Operating Pressure Limitations (psi) .....	T4-35
Petroleum-Base Fluid (Hydraulic) .....	2-3b
Pipe Thread, Straight Thread and .....	F4-26
Piston Damper .....	F4-162
Piston Damper Cross Section .....	F4-163
Piston Damper, Nose Landing Gear with .....	F4-164
Piston Dampers, Main Rotor Assembly with .....	F4-165
Piston-Type Pressure Switch .....	F4-115
Plastic Protective Dust Cap .....	F4-55
Plastic Protective Dust Cap (AN-SAE Friction) .....	F4-56
Plastic Protective Dust Plug and Moisture Seal (AN-SAE Threaded) .....	F4-51
Pneudraulic Systems, Types of .....	4-17
Closed-Center Hydraulic .....	4-17b
Open-Center Hydraulic .....	4-17a
Pneumatic System .....	4-17c
Pneudraulics Theory and Basic Principles .....	2-1
Computation of Force, Area, and Pressure .....	2-1b
Computation of Volume, Area, and Length of Stroke .....	2-1c
Mechanical Advantage .....	2-1 e, F2-4
Pascal's Law .....	2-1d, F2-3
Qualities of Hydraulic Fluid .....	2-1a
Use of Air in Hydraulic Systems .....	2-1f
Pneumatic System .....	4-17c
Power Brake Control Valve (Brake Applied) .....	F4-152
Power Brake Control Valve (Brake Released) .....	F4-153
Power Pumps .....	4-13a
Power-Boost Master Cylinder (Brake Applied) .....	F4-150
Power-Boost Master Cylinder (Brake Released) .....	F4-151
Precautions	
for Hydraulic Fluid Selection and Contamination .....	2-3d
for Repair of Tubing Assemblies .....	4-4a
Pressure Gauge .....	F4-114
Pressure Gauges .....	4-14a
Pressure Reducing Valve .....	4-14d
Pressure Relief Valves .....	4-14c
Pressure Switch, Piston-Type .....	F4-115
Pressure Switches .....	4-14b
Pressure-Actuated Sequence Valve .....	F4-130

**INDEX - CONT**

<b>Subject</b>	<b>Paragraph, Figure, Table Number</b>
----------------	--

**P - Continued**

Pressure-Reducing Valve .....	F4-117
Pressures, Proof Test, High-Pressure Teflon Hose Assemblies .....	T4-30
Pressures, Proof Test, Medium-Pressure Teflon Hose Assemblies .....	T4-23
Printed-Symbol Identification Tape .....	F4-1
Priority Valve .....	F4-131
Procedures, for Use of Test Stands .....	4-20b
Proof Test and Operating Pressure (psi) for MIL-H-7061 .....	T4-31
Proof Test Pressures, High-Pressure Teflon Hose Assemblies .....	T4-28
Proof Test Pressures, Medium-Pressure Teflon Hose Assemblies .....	T4-23
Proof Test Torque Values MS Flared Swivel Nut Fittings (Reference AND10064) .....	T4-20
Proof Testing of Flexible Hose Assemblies .....	4-5f
Properly Burred Tube .....	F4-9
Pump Assembly, Kellogg Stroke Reduction .....	F4-109
Pump, Constant Volume, Bent-Axis .....	F4-101
Pump, Constant Volume, Foot Valve .....	F4-104
Pump, Constant Volume, (Piston Installation) .....	F4-102
Pump, Constant Volume, (Piston Operation) .....	F4-103
Pump, Hand, Double-Action .....	F4-111
Pump, Hand, Test Circuit .....	F4-112
Pump, Kellogg Stroke Reduction (Reduction Output) .....	F4-110
Pump, Stratopower Effective Stroke (Full Flow) .....	F4-105
Pump, Stratopower Effective Stroke (Zero Flow) .....	F4-106
Pump, Vickers Stroke Reduction (Full Flow) .....	F4-108
Pump, Vickers Stroke Reduction (Zero Flow) .....	F4-107
Pumps and Motors .....	4-13
Hand Pumps .....	4-13c
Hydraulic Motors .....	4-13d
Maintenance of Power Pumps .....	4-13b
Power Pumps .....	4-13a
Purpose (of Manual) .....	1-1

**Q**

Qualities of Hydraulic Fluid .....	2-1a
Quick-Disconnect Couplings .....	4-10
Inspection .....	4-10b
Installation .....	4-10a

**R**

Ratchet Valve .....	4-16h
Ratchet Valve (Moving) .....	F4-137
Ratchet Valve (Static) .....	F4-136
Radial Cam-Operated Selector Valve .....	F4-124
Recommended (Permaswage) Repair Methods, Failure Modes and .....	F4-79



**INDEX - CONT**

<b>Subject</b>	<b>Paragraph, Figure, Table Number</b>
----------------	--

**R - Continued**

Regulating Pressure, Devices for .....	4-14
Relief Valve, System .....	F4-116
Repair	
of High-Pressure Tubing Assemblies .....	4-4c
of Low-Pressure Tubing Assemblies .....	4-4b
of Tubing Assemblies .....	4-4
Repair of Low-Pressure Tubing .....	F4-30
Repair of Tubing Assemblies .....	4-4
Precautions .....	4-4a
Repair of High-Pressure Tubing Assemblies .....	4-4c
Repair of Low-Pressure Tubing Assemblies .....	4-4b
Template .....	4-4d
Repairing High-Pressure Tubing .....	F4-33
Replacement of Flexible Hose .....	4-5c
Reservoir, Fluid-Pressurized (Pressurized) .....	F4-93
Reservoir, Fluid-Pressurized (Unpressurized) .....	F4-92
Reservoir with Baffles, Fins and Finger Strainer .....	F4-91
Reservoir with Filter Elements .....	F4-94
Reservoirs, Hydraulic .....	4-11
Responsibility (for Hydraulic Shop Rules) .....	3-1a
Reversing Spiral of Teflon Backup Ring .....	F4-74
Rings, Backup .....	4-8
Rotary-Type, Closed-Center Selector Valve .....	F4-120
Rotor Blade Brake System .....	F4-159

**S**

Safety (in Use of Test Stands) .....	4-20a
Scope (of Manual) .....	1-2
Selector Valve A Closed .....	F4-145
Selector Valve B Open .....	F4-146
Selector Valve C Open' .....	F4-147
Selector Valve, In-Line Cam-Operated (Actuator Extending) .....	F4-123
Selector Valve, In-Line Cam-Operated (Actuator Retracting) .....	F4-122
Selector Valve, Radial Cam-Operated .....	F4-124
Selector Valve, Rotary-Type, Closed-Center .....	F4-120
Selector Valve, Spool-Type, Open-Center (Closed) .....	F4-121
Selector Valves .....	4-16a
Self-Sealing, Aromatic-Resisting, Hose MIL-H-7061 .....	F4-38
Self-Sealing, Hose for Aromatic Fuel, MIL-H-7061 .....	4-5k
Separable Fittings, Utilizing 0.150 Tube End Gap Tolerance on .....	F4-89
Sequence Valve, Landing Gear System Using Mechanically Actuated .....	F4-129

**INDEX - CONT**

<b>Subject</b>	<b>Paragraph, Figure, Table Number</b>
<b>S - Continued</b>	
Sequence Valve, Pressure-Actuated .....	F4-130
Sequence Valves .....	4-16d
Servicing Filters .....	4-12f
Shaped Fittings, Utilizing 0.300 Inch Tube End Gap Tolerance on .....	F4-92
Shock Strut, Complex (Metering Pin) .....	F4-171
Shock Strut, Complex (Plunger) .....	F4-172
Shock Strut, Floating Pin .....	F4-173
Shock Strut, Simple .....	F4-170
Shock Struts .....	4-19b
Shop Equipment, Maintenance .....	3-2
Shop Housekeeping (Hydraulic Shop) .....	3-1b
Shop Rules, General (Hydraulic Shop) .....	3-1
Shop Safety (Hydraulic Shop) .....	3-1c
Shop Tools and Materials (Hydraulic Shop) .....	3-1d
Shuttle Valve, Floating-Piston .....	F4-132
Shuttle Valves .....	4-16f
Simple Check Valve .....	F4-127
Simple Master Cylinder .....	F4-148
Simple Shock Strut .....	F4-170
Single Backup Ring Installation .....	F4-75
Single Flared Tubing, Dimensions for .....	F4-7
Single-Action Actuating Cylinder .....	F4-133
Size (of Hydraulic Systems) .....	2-2d
Solenoid-Actuated Control Valve (De-energized) .....	F4-126
Solenoid-Actuated Control Valve (Energized) .....	F4-125
Solid Color Band Identification .....	F4-2
Spherical Accumulator .....	F4-119
Spherical Air Cylinder .....	F4-95
Spool-Type, Open-Center, Selector Valve (Closed) .....	F4-121
Stabilizer Bar with Vane Dampers .....	F4-169
Standard Union Fittings, Tube Insertion Limits when Using .....	F4-90
Standard Union Fittings, Utilizing 0.300 Inch Tube End Gap Tolerance with .....	F4-87
Standpipes .....	4-11g
Steel Protective Dust Cap .....	F4-53
Steel Protective Dust Plug and Moisture Seal .....	F4-52
Storage of Hose and Hose Assemblies .....	4-5b
Storage (55-Gallon Drums) .....	3-3a
Straight Pipe Thread .....	4-3c
Straight Thread and Pipe Thread .....	F4-26
Stratopower Effective Stroke Pump (Full Flow) .....	F4-105
Stratopower Effective Stroke Pump (Zero Flow) .....	F4-106
Stretching Teflon Backup Ring .....	F4-72
Support Clamp Sizes (for Use with MIL-H-27267 Hose of Teflon) .....	T4-24
Support Clamp Sizes (for Use with MIL-H-38360 Hose of Teflon) .....	T4-29

**INDEX - CONT**

<b>Subject</b>	<b>Paragraph, Figure, Table Number</b>
<b>S - Continued</b>	
Support, of Flexible Hose .....	4-6e
Swage Tool Assembly Showing Lower Die Block Assembly and Position of Fitting Locator, Basic .....	F4-84
Swaged Joint, Checking, with D9892 Inspection Gauge .....	F4-85
Swaged Tubing Repairs .....	4-9
Application .....	4-9a
Inspection of Swaged Joint .....	4-9g
Swaging Operation .....	4-9f
Technique .....	4-9b
Tube Cutting .....	4-9c
Tube Deburring .....	4-9d
Tube End Preparation .....	4-9e
Swaging, Fitting Dimensions After .....	T4-39
Swaging Operation .....	4-9f
Synthetic-Base Fluid MIL-H-83282 .....	2-3c
System Flushing .....	2-4b
System Relief Valve .....	F4-116
Systems and Repairs, Tubing .....	4-2

**T**

Tailwheel Liquid Spring .....	T4-176
Technique, Swaged Tubing Repairs .....	4-9b
Teflon Hose Assembly Procedure, Medium-Pressure .....	F4-48
Teflon Hose Cutoff Failures (in Inches) .....	F4-23
Teflon Hose, Field Disassembly of .....	F4-47
Teflon Hose Installation Procedures, Right and Wrong .....	F4-49
Temperature Protection and Installation of Flexible Hose .....	4-6g
Template for Repair of Tubing Assemblies .....	4-4d
Test Pressures, Operating, Proof, and Burst, for AN6270 Hose Assembly using MIL-H-5593 Low Pressure Hose .....	T4-19
Test Pressures, Operating, Proof, and Burst, for MIL-H-83796 Medium Pressure Hose Assembly .....	T4-17
Test Pressures, Operating, Proof, and Burst, for MIL-H-83797 Medium Pressure Hose .....	T4-18
Test Pressures, Operating, Proof, and Burst, for MS28741 Medium Pressure Hose Assemblies, using Single Wire Braid Hose, Military Specification MIL-H-8794 .....	T4-16
Test Pressures, Operating, Proof, and Burst, for MS28759 and MS28762 Hose Assemblies .....	T4-15
Test Stands, Use of .....	4-20
Tetrafluoroethylene Hose MIL-F-27272 (in Inches) .....	T4-21
Tetrafluoroethylene Hose MIL-H-38360 (in Inches) .....	T4-26
Theory and Basic Principles of Pneudraulics .....	2-1
Theory of Operation, Hydraulic Reservoirs .....	4-11b
Theory of Operation, Hydraulics System Filters .....	4-12b

**INDEX - CONT**

<b>Subject</b>	<b>Paragraph, Figure, Table Number</b>
<b>T - Continued</b>	
Tightening Hose Clamp with Socket .....	F4-32
Tool, Flaring .....	F4-10
Torque Values for AN924 Jamnut Used On Fittings .....	T4-8
Torque Values for Boss Installation .....	T4-7
Torque Values for MS21921 Coupling Nut .....	T4-5
Torque Values, Hydraulic Tubing B-Nut (AN818) .....	T4-2
Torque Values, Installation, MS Flared Swivel .....	T4-25
Torque Values, MS Flared Swivel Nut Fittings (Reference AND10064), Installation .....	T4-33
Torque Values, MS Flared Swivel Nut Fittings (Reference AND10064), Proof Test .....	T4-20
Torque Values, MS Turns and .....	F4-21
Transporting Fluid to Aircraft .....	3-3d
Troubleshooting Actuators .....	T4-40
Troubleshooting Guide for Inspection Checking (of Swaging) .....	T4-38
Troubleshooting Wheel Brake Systems .....	T4-41
Tube and Fitting Alignment .....	T4-13
Tube Bend Data Drawing .....	F4-6
Tube Bending Machine .....	F3-4
Tube Bending Machine, Hand-Operated .....	3-2e
Tube Bends, Acceptable and Unacceptable .....	F4-5
Tube Cutter, Cutting Tube with .....	F4-3
Tube Cutting .....	4-9c
Tube Deburring .....	4-9d
Tube End Marking .....	F4-83
Tube Insertion Band Location .....	T4-37
Tube Insertion Limits when Using Standard Union Fittings .....	F4-90
Tube Material and Maximum Operating Pressure Limitations (psi) for Permaswage Repair with D1 0000 Series Tooling .....	T4-35
Tube, Properly Burred .....	F4-9
Tube Thickness and Burst Pressure, Determining .....	T4-11
Tubing Alignment .....	F4-20
Tubing Assemblies, Repair of .....	4-4
Tubing Damage .....	4-2c
Tubing End Clearance for Low-Pressure Tubing-Repair .....	F4-31
Tube Fittings .....	F4-15
Tubing Identification .....	4-2b
Tubing Repairs, Swaged .....	4-9
Tubing Systems and Repairs .....	4-2
Beaded Tubing Joints .....	4-2h
Bending Tubing .....	4-2e
Cleaning Tubing .....	4-2g
Cutting Tubing .....	4-2d
Flaring Tubing .....	4-2f
Installation of Beaded Tubing .....	4-2j
Installation of Flared Tubing .....	4-2i
Tubing Damage .....	4-2c

**INDEX - CONT**

<b>Subject</b>	<b>Paragraph, Figure, Table Number</b>
----------------	--

**T - Continued**

Tubing Identification .....	4-2b
Types .....	4-2a
Tubing with Double Lap Flare .....	F4-11
Tubing-to-Tubing Connections .....	F4-22
Two-Stage Fluid Filters .....	4-12d
Types of Accumulators .....	4-15a
Types of Hydraulic Fluid Used in Army Aircraft .....	2-3
Petroleum-Base Fluid .....	2-3b
Precautions .....	2-3d
Synthetic-Base Fluid MIL-H-83282 .....	2-3c
Vegetable-Base Fluid .....	2-3a
Types of Hydraulic Reservoirs Used in Hydraulic Systems .....	4-11a
Types of Pneudraulic Systems .....	4-17
Types of Tubing Systems and Repairs .....	4-2a
Typical Gasoline Engine-Driven Hydraulic Test Stand .....	F3-2
Typical Hydraulic Hose Testing Unit .....	F3-3
Typical Hydraulic System Filler and Bleeder .....	F3-1
Typical Master Gauge Unit .....	F3-5
Typical Styles of Permaswage Fittings .....	F4-78

**U**

Universal Fittings AN832, AN833, AN834 High Pressure .....	4-3e
Universal Fittings AN832, AN833, AN834 Low Pressure .....	4-3d
Use of Air in Hydraulic Systems .....	2-1f
Use of Dust Plugs, Dust Caps, and Moisture Seals .....	4-51
Use of Test Stands .....	4-20
Procedures .....	4-20b
Safety .....	4-20a
Uses of Filter in Hydraulic Systems .....	4-12a
Uses of Hydraulic Systems in Army Aircraft .....	2-2
Ease of Installation .....	2-2c
Ease of Operation .....	2-2b
Efficiency .....	2-2a
Lubrication .....	2-2e
Size .....	2-2d
Utilizing 0.150 Inch Tube End Gap Tolerance on Separable Fittings .....	F4-89
Utilizing 0.300 Inch Tube End Gap Tolerance on Shaped Fittings .....	F4-88
Utilizing 0.300 Inch Tube End Gap Tolerance with Standard Union Fittings .....	F4-87
V-Ring Packings .....	4-7c
V-Ring Packings in Various Positions of Assembly .....	F4-71
Valve A, Closed .....	F4-145
Valve B, Open .....	F4-146
Valve C, Open .....	F4-147
Valve, Pressure-Reducing .....	F4-117
Valve, Priority .....	F4-131
Valve, Ratchet (Moving) .....	F4-137

**INDEX - CONT**

<b>Subject</b>	<b>Paragraph, Figure, Table Number</b>
----------------	--

**U - Continued**

Valve, Ratchet (Static) .....	F4-136
Valve, Priority .....	F4-131
Vane Damper .....	F4-166
Vane Damper Cross Section .....	F4-167
Vane, Dampers, Nose Landing Gear .....	F4-168
Vane, Dampers, Stabilizer Bar .....	F4-169
Vegetable-Base Fluid (Hydraulic) .....	2-3a
Vickers Stroke Reduction Pump (Full Flow) .....	F4-108
Vickers Stroke Reduction Pump (Zero Flow) .....	F4-107
Volume, Length, and Area, Computing .....	F2-2

**W**

Wheel Brake Assemblies .....	4-18b
Wheel Brake Systems .....	4-18a
Wheel Brake Systems, Troubleshooting .....	T4-41
Withdrawing Fluid from Drum .....	T3-3c

TM 1-1500-204-23-2

By Order of the Secretary of the Army:

Official:



MILTON H. HAMILTON  
Administrative Assistant to the  
Secretary of the Army  
02557

GORDON R. SULLIVAN  
General, United States Army  
Chief of Staff

**DISTRIBUTION:**

To be distributed in accordance with DA Form 12-31-E, block no. 3226, requirements for TM 1-1500-204-23-2.

## ***These are the instructions for sending an electronic 2028***

The following format must be used if submitting an electronic 2028. The subject line must be exactly the same and all fields must be included; however only the following fields are mandatory: 1, 3, 4, 5, 6, 7, 8, 9, 10, 13, 15, 16, 17, and 27.

From: "Whomever" <whomever@avma27.army.mil>

To: ls-lp@redstone.army.mil

Subject: DA Form 2028

1. From: Joe Smith
2. Unit: home
3. Address: 4300 Park
4. City: Hometown
5. St: MO
6. Zip: 77777
7. Date Sent: 19-OCT-93
8. Pub no: 1-1500-204-23-2
9. Pub Title: TM
10. Publication Date: 31-JUL-92
11. Change Number: 7
12. Submitter Rank: MSG
13. Submitter FName: Joe
14. Submitter MName: T
15. Submitter LName: Smith
16. Submitter Phone: 123-123-1234
17. Problem: 1
18. Page: 2
19. Paragraph: 3
20. Line: 4
21. NSN: 5
22. Reference: 6
23. Figure: 7
24. Table: 8
25. Item: 9
26. Total: 123
27. Text:

This is the text for the problem below line 27.







# SOMETHING WRONG WITH THIS PUBLICATION?

THEN...NOT DOWN THE DOPE ABOUT IT ON THIS FORM, CAREFULLY TEAR IT OUT, FOLD IT AND DROP IT IN THE MAIL!

FROM: (PRINT YOUR UNIT'S COMPLETE ADDRESS)

*PFC John DOE  
 CO 4 3rd Engineer Bn  
 Ft. Leonardwood, MO 63108*

DATE SENT

*22 August 1992*

PUBLICATION NUMBER

TM 1-1520-250-10

PUBLICATION DATE

15 June 1992

PUBLICATION TITLE

Operator's manual MH60K Helicopter

BE EXACT PIN-POINT WHERE IT IS

IN THIS SPACE, TELL WHAT IS WRONG AND WHAT SHOULD BE DONE ABOUT IT:

PAGE NO	PARA-GRAPH	FIGURE NO	TABLE NO
6	2-1 a		
B1		4-3	

*In line 6 of paragraph 2-1a the manual states the engine has 6 cylinders. The engine on my set only has 4 cylinders. Change the manual to show 4 cylinders.*

*Callout 16 in figure 4-3 is pointed at a bolt. In key to figure 4-3, item 16 is called a shim. Please correct one or the other*

PRINTED NAME, GRADE OR TITLE, AND TELEPHONE NUMBER

*JOHN DOE, PFC (268) 317-7111*

SIGN HERE

*John Doe*  
 JOHN DOE

**DA FORM 2028-2**  
 1 JUL 79

PREVIOUS EDITIONS ARE OBSOLETE.  
 DRSTS-M verprint2, 1 Nov 80

P.S. - IF YOUR OUTFIT WANTS TO KNOW ABOUT YOUR RECOMMENDATION, MAKE A CARBON COPY OF THIS AND GIVE TO YOUR HEADQUARTERS.

REVERSE OF DA FORM 2028-2 Reverse of DRSTS-M Overprint 2,

1 Nov 80

FILL IN YOUR  
UNITS ADDRESS



FOLD BACK

DEPARTMENT OF THE ARMY

\_\_\_\_\_

\_\_\_\_\_

OFFICIAL BUSINESS

COMMANDER  
U.S. ARMY AVIATION AND MISSILE COMMAND  
ATTN: AMSAM-MMC-LS-LP  
REDSTONE ARSENAL, AL 35898-5230

TEAR ALONG PERFORATED LINE



FILL IN YOUR  
UNITS ADDRESS



FOLD BACK

DEPARTMENT OF THE ARMY

---

---

OFFICIAL BUSINESS

COMMANDER  
U.S. ARMY AVIATION AND MISSILE COMMAND  
ATTN: AMSAM-MMC-LS-LP  
REDSTONE ARSENAL, AL 35898-5230

TEAR ALONG PERFORATED LINE



FILL IN YOUR  
UNITS ADDRESS



FOLD BACK

DEPARTMENT OF THE ARMY

\_\_\_\_\_

\_\_\_\_\_

OFFICIAL BUSINESS

COMMANDER  
U.S. ARMY AVIATION AND MISSILE COMMAND  
ATTN: AMSAM-MMC-LS-LP  
REDSTONE ARSENAL, AL 35898-5230

TEAR ALONG PERFORATED LINE





REVERSE OF DA FORM 2028-2 Reverse of DRSTS-M Overprint 2,

1 Nov 80

FILL IN YOUR  
UNITS ADDRESS



FOLD BACK

TEAR ALONG PERFORATED LINE

DEPARTMENT OF THE ARMY

\_\_\_\_\_

\_\_\_\_\_

OFFICIAL BUSINESS

COMMANDER  
U.S. ARMY AVIATION AND MISSILE COMMAND  
ATTN: AMSAM-MMC-LS-LP  
REDSTONE ARSENAL, AL 35898-5230

## The Metric System and Equivalents

### Linear Measure

1 centimeter = 10 millimeters = .39 inch  
 1 decimeter = 10 centimeters = 3.94 inches  
 1 meter = 10 decimeters = 39.37 inches  
 1 dekameter = 10 meters = 32.8 feet  
 1 hectometer = 10 dekameters = 328.08 feet  
 1 kilometer = 10 hectometers = 3,280.8 feet

### Weights

1 centigram = 10 milligrams = .15 grain  
 1 decigram = 10 centigrams = 1.54 grains  
 1 gram = 10 decigrams = .035 ounce  
 1 decagram = 10 grams = .35 ounce  
 1 hectogram = 10 decagrams = 3.52 ounces  
 1 kilogram = 10 hectograms = 2.2 pounds  
 1 quintal = 100 kilograms = 220.46 pounds  
 1 metric ton = 10 quintals = 1.1 short tons

### Liquid Measure

1 centiliter = 10 milliliters = .34 fl. ounce  
 1 deciliter = 10 centiliters = 3.38 fl. ounces  
 1 liter = 10 deciliters = 33.81 fl. ounces  
 1 dekaliter = 10 liters = 2.64 gallons  
 1 hectoliter = 10 dekaliters = 26.42 gallons  
 1 kiloliter = 10 hectoliters = 264.18 gallons

### Square Measure

1 sq. centimeter = 100 sq. millimeters = .155 sq. inch  
 1 sq. decimeter = 100 sq. centimeters = 15.5 sq. inches  
 1 sq. meter (centare) = 100 sq. decimeters = 10.76 sq. feet  
 1 sq. dekameter (are) = 100 sq. meters = 1,076.4 sq. feet  
 1 sq. hectometer (hectare) = 100 sq. dekameters = 2.47 acres  
 1 sq. kilometer = 100 sq. hectometers = .386 sq. mile

### Cubic Measure

1 cu. centimeter = 1000 cu. millimeters = .06 cu. inch  
 1 cu. decimeter = 1000 cu. centimeters = 61.02 cu. inches  
 1 cu. meter = 1000 cu. decimeters = 35.31 cu. feet

## Approximate Conversion Factors

<i>To change</i>	<i>To</i>	<i>Multiply by</i>	<i>To change</i>	<i>To</i>	<i>Multiply by</i>
inches	centimeters	2.540	ounce-inches	Newton-meters	.007062
feet	meters	.305	centimeters	inches	.394
yards	meters	.914	meters	feet	3.280
miles	kilometers	1.609	meters	yards	1.094
square inches	square centimeters	6.451	kilometers	miles	.621
square feet	square meters	.093	square centimeters	square inches	.155
square yards	square meters	.836	square meters	square feet	10.764
square miles	square kilometers	2.590	square meters	square yards	1.196
acres	square hectometers	.405	square kilometers	square miles	.386
cubic feet	cubic meters	.028	square hectometers	acres	2.471
cubic yards	cubic meters	.765	cubic meters	cubic feet	35.315
fluid ounces	milliliters	29.573	cubic meters	cubic yards	1.308
pints	liters	.473	milliliters	fluid ounces	.034
quarts	liters	.946	liters	pints	2.113
gallons	liters	3.785	liters	quarts	1.057
ounces	grams	28.349	liters	gallons	.264
pounds	kilograms	.454	grams	ounces	.035
short tons	metric tons	.907	kilograms	pounds	2.205
pound-feet	Newton-meters	1.356	metric tons	short tons	1.102
pound-inches	Newton-meters	.11296			

## Temperature (Exact)

°F	Fahrenheit temperature	5/9 (after subtracting 32)	Celsius temperature	°C
----	---------------------------	-------------------------------	------------------------	----



This fine document...

Was brought to you by me:



## [Liberated Manuals -- free army and government manuals](#)

Why do I do it? I am tired of sleazy CD-ROM sellers, who take publicly available information, slap “watermarks” and other junk on it, and sell it. Those masters of search engine manipulation make sure that their sites that sell free information, come up first in search engines. They did not create it... They did not even scan it... Why should they get your money? Why are not letting you give those free manuals to your friends?

I am setting this document FREE. This document was made by the US Government and is NOT protected by Copyright. Feel free to share, republish, sell and so on.

I am not asking you for donations, fees or handouts. If you can, please provide a link to [liberatedmanuals.com](http://www.liberatedmanuals.com), so that free manuals come up first in search engines:

<A HREF=<http://www.liberatedmanuals.com/>>Free Military and Government Manuals</A>

- Sincerely  
Igor Chudov  
<http://igor.chudov.com/>
- [Chicago Machinery Movers](#)