

(Air Force) T.O. 12P4-2APX-142
(Navy) NAVAIR 16-35C6280-1
(Army) TM 11-5841-268-25

TECHNICAL MANUAL

ORGANIZATIONAL/FIELD/INTERMEDIATE/
DS, GS, AND DEPOT MAINTENANCE
WITH ILLUSTRATED PARTS BREAKDOWN

CONTROL, TRANSPONDER SET

**C-6280(P)/APX, C-6280A(P)/APX,
C-67171APX, & C-7483/APX**

ADMIRAL
AIRCRAFT RADIO

THIS PUBLICATION REPLACES
T.O. 12P4-2APX-142 AND NAVAIR 16-35C6280-1, DATED 15 OCTOBER 1966
AND
TM 11-5841-268-25, DATED JULY 1967

**This copy is a reprint which includes current
pages from Changes 1 and 2**

PUBLISHED UNDER AUTHORITY OF THE SECRETARIES OF THE AIR FORCE, THE NAVY, AND THE ARMY

1 NOVEMBER 1969

T.O. 12P4-2APX-142
NAVAIR 16-35C6280-1
TM 11-5641-268-25

Reproduction for non-military use of the information or illustrations contained in this publication is not permitted. The policy for military use reproduction is established for the Army in AR 380-5, for the Navy and Marine Corps its OPNAVINST 5510.1 B, and for the Air Force in Air Force Regulation 205-1.

LIST OF EFFECTIVE PAGES

Insert latest changed pages; dispose of superseded pages in accordance with applicable regulations.

NOTE: On a changed page, the portion of the text affected by the latest change is indicated by a vertical line, or other change symbol, in the outer margin of the page. Changes to illustrations are indicated by miniature pointing hands. Changes to wiring diagrams are indicated by shaded areas.

Total number of pages in this manual is 66 consisting of the following:

<i>Page No.</i>	<i># Change No.</i>
Title	0
A	0
B	0
C Blank	0
i thru ii	0
iii Blank	0
1-0 thru 1-5	0
1-6 Blank	0
2-1/3-1	0
3-2 Blank	0
4-1 thru 4-2	0
4-3/5-1/6-1	0
6-2 Blank	0
7-1 thru 7-8	0
8-1 thru 8-5	0
8-6 Blank	0
9-1/10-1	0
10-2 thru 10-15	0
10-16 Blank	0
A-1	0
A-2 Blank	0
B-1	0
B-2 Blank	0
C-1 thru C-2	0
FO-1	0
FO-2 Blank	0
FO-3	0
FO-4 Blank	0
FO-5	0
FO-6 Blank	0
FO-7	0
FO-8 Blank	0
FO-9	0
FO-10 Blank	0

Zero in this column indicates an original page.

T.O. 12P4-2APX-142
NAVAIR 16-35C6280-1
TM 11-5841-268-25

Reproduction for non-military use of the information or illustrations contained in this publication is not permitted. The policy for military use reproduction is established for the Army in AR 380-5, for the Navy and Marine Corps in OPNAVINST 5510.1 B, and for the Air Force in Air Force Regulation 205-1.

LIST OF EFFECTIVE PAGES

Insert latest changed pages; dispose of superseded pages in accordance with applicable regulations.

NOTE: On a changed page; the portion of the text affected by the latest change is indicated by a vertical line, or other change symbol, in the outer margin of the page. Changes to illustrations are indicated by miniature pointing' hands. Changes to wiring diagrams are indicated by shaded areas.

Total number of pages in this manual is 66 consisting of the following:

Page No.	# Change No.	Page No.	# Change No.
Title	1	9-1/10-1	0
A	1	10-2 thru 10-12	0
B	1	10-13	1
C Blank	0	10-14 thru 10-15	0
i thru ii	0	10-16 Blank	0
iii Blank	0	A-1	0
1-0	0	A-2 Blank	0
1-1	1	B-1	0
1-2 thru 1-5	0	B-2 Blank	0
1-6 Blank	0	C-1 thru C-2	0
2-1/3-1	1	FO-1	0
3-2	1	FO-2 Blank	0
4-1 thru 4-2	0	FO-3	1
4-3/5-1/6-1	0	FO-4 Blank	0
6-2 Blank	0	FO-5	0
7-1 thru 7-8	0	FO-6 Blank	0
8-1	0	FO-7	0
8-2	1	FO-8 Blank	0
8-3 thru 8-5	0	FO-9	0
8-6 Blank	0	FO-10 Blank	0

Zero in this column indicates an original page.

T.O. 12P4-2APX-142
NAVAIR 16-35C6280-1
TM 11-5841-268-26

LIST OF EFFECTIVE PAGES

Insert latest changed pages; dispose of superseded pages in accordance with applicable regulations.

NOTE: On a changed page, the portion of the text affected by the latest change is indicated by a vertical line, or other change symbol, in the outer margin of the page. Changes to illustrations are indicated by miniature pointing hands. Changes to wiring diagrams are indicated by shaded areas.

Total number of pages in this manual is 66 consisting of the following:

Page No.	# Change No.	Page No.	# Change No.
Title	2	9-1/10-1	0
A	2	10-2 thru 10-4	0
B	1	10-5	2
C Blank	0	10-6 thru 10-12	0
i thru ii	0	10-13	2
iii Blank	0	10-14 thru 10-15	0
1-0	0	10-16 Blank	0
1-1	1	A-1	0
1-2 thru 1-5	0	A-2 Blank	0
1-6 Blank	0	B-1	0
2-1/3-1	1	B-2 Blank	0
3-2	1	C-1 thru C-2	0
4-1 thru 4-2	0	FO-1	0
4-3/5-1/6-1	0	FO-2 Blank	0
6-2 Blank	0	FO-3	1
7-1 thru 7-8	0	FO-4 Blank	0
8-1	0	FO-5	0
8-2	1	FO-6 Blank	0
8-3 thru 8-5	0	FO-7	0
8-6 Blank	0	FO-8 Blank	0
		FO-9	0
		FO-10 Blank	0

#Zero in this column indicates an original page.

(Navy) **RECORD OF CHANGES**

<i>CHANGE NO.</i>	<i>DATE</i>	<i>TITLE OR BRIEF DESCRIPTION</i>	<i>ENTERED BY</i>
AVC-900	1 Feb 1969	C-6280(P) Control Master Switch and Wiring Modification	

TABLE OF CONTENTS

<i>Section</i>	<i>Page</i>	<i>Section</i>	<i>Page</i>
I DESCRIPTION AND LEADING PARTICULARS	1-1	8-5. Removal and Replacement of Rear Panel Assembly	8-1
1-1. General	1-1	8-7. Repair and Replacement of Connector J201	8-1
1-5. Indexes of Publications.	1-1	8-13. Replacement of Toggle Switches	8-2
1-8. Forms and Records	1-1	8-15. Replacement of Rotary Switches	8-2
1-13. Purpose of Equipment	1-1	8-17. Replacement of Thumbwheel Switches	8-2
1-15. Description of Equipment	1-3	8-19. Removal and Replacement of Parts on Thumbwheel Switch Assemblies	8-3
1-29. Operating Controls and Indicators	14	8-23. Replacement of Indicator Lights	8-4
II PREPARATION FOR MAINTENANCE	2-1	8-25. Replacement of Panel Light Bases of C45280(P)/APX and C-6280A(P)/APX	8-4
III TEST EQUIPMENT AND SPECIAL TOOLS	3-1	8-27. Replacement of Panel Lamps of C-6717/APX and C-7483/APX	8-4
3-1. Test Equipment Required	3-1	8-29. Lubrication	8-4
3-3. Tools Required	3-1	8-31. Equipment Performance Check After Completion of Repairs	8-4
3-5. Test Wiring	3-1	8-33. (Army) Depot Overhaul Standards	84
3-7. Power Source	3-1	8-41. Packaging for Storage or Shipment.	8-5
IV THEORY OF OPERATION.	4-1	IX (Army) DEMOLITION OF MATERIEL TO PREVENT ENEMY USE	9-1
4-1. Introduction	4-1	9-1. Authority for Demolition	9-1
4-3. Code Number Selection	4-1	9-3. Methods of Destruction	9-1
V DESCRIPTION OF SYSTEM TIE-IN OF EQUIPMENT AND ACCESSORIES	5-1	9-5. Report of Destruction	9-1
VI SYSTEM CHECK-OUT	6-1	X (Air Force, Navy) ILLUSTRATED PARTS BREAKDOWN	10-1
VII MAINTENANCE INSTRUCTIONS	7-1	10-1. Scope and Applicability	10-1
7-1. General	7-1	10-3. Group Assembly Parts Lists.	10-1
7-3. (Army) Preventive Maintenance	7-1	10-5. Numerical Index and Reference Designation Index.	10-1
7-5. (Army) Intermediate Preventive Maintenance Checks and Services	7-1	10-7. Part Numbers	10-2
7-7. (Army) Intermediate Preventive Maintenance Checks and Services Chart	7-1	10-10. Usable On Codes	10-2
7-8. (Army) Cleaning	7-2	10-14. Source Codes	10-2
7-10. (Army) Periodic Preventive Maintenance Checks and Services	7-2	10-17. List of Manufacturers.	10-4
7-12. (Army) Periodic Preventive Maintenance Checks and Services Chart	7-2	A REFERENCES	A-1
7-13. Malfunction Recognition.	7-2	B (Army) BASIC ISSUE ITEMS	B-1
7-16. Preliminary Inspection	7-2	B-1. Scope	B-1
7-18. Trouble Location	7-2	B-3. Explanation of Columns	B-1
7-20. Panel Light Check	7-3	C (Army) MAINTENANCE ALLOCATION.	C-1
7-22. Indicator Light Check.	7-3	C-1. General	C-1
7-25. Control Switch Check.	7-3	C-2. Maintenance Functions.	C-1
VIII REPAIR AND OVERHAUL INSTRUCTIONS	8-1	C-3. Explanation of Format	C-1
8-1. General	8-1	C-9. Explanation of Format of Tool and Test Equipment Requirements Chart	C-2
8-3. Replacement of Plastic Light Panel.	8-1		

T.O. 12P4-2APX-142
NAVAIR 16-35C6280-1
TM 11-5841-268-25

LIST OF ILLUSTRATIONS

<i>Number</i>	<i>Title</i>	<i>Page</i>	<i>Number</i>	<i>Title</i>	<i>Page</i>
1-1.	Control, Transponder Set C-6280(P)/APX, C-6280A(P)/APX, C-6717/APX, and C-7483/APX	1-0	10-1.	Switch Assembly, Exploded View	10-11
1-2.	Control, Transponder Set C-6280(P)/APX, C-6280A(P)/APX, C-6717/APX, and C-7483/APX, External Wiring Diagram. . .	1-2	FO-1.	Control, Transponder Set C-6280(P)/APX, C-6280A(P)/APX, C-6717/APX, and C-7483/APX, Schematic Diagram.	FO-1
1-3.	Operating Controls and Indicators	14	FO-2.	Control, Transponder Set C-6280(P)/APX, C-6280A(P)/APX, C-6717/APX, and C-7483/APX, Wiring Diagram	FO-3
4-1.	IFF and SIF Reply Code Pulse Trains.	4-2	FO-3.	Control, Transponder Set C-6280(P)/APX, Exploded View	FO-5
8-1.	Thumbwheel Switch Assembly, Exploded View	8-3	FO-4.	Control, Transponder Set C-6280A(P)/APX, Exploded View	FO-7
8-2.	Control, Transponder Set C-6280(P)/APX, C-6280A(P)/APX, C-6717/APX, and C-7483/APX, Packaging Diagram.	8-5	FO-5.	Control, Transponder Set C-6717/APX and C-7483/APX, Exploded View	FO-9

LIST OF TABLES

<i>Number</i>	<i>Title</i>	<i>Page</i>
1-1.	Operating Controls and Indicators	1-4
4-1.	Mode I Code Number Selection	4-1
4-2.	Mode 3/A Code Number Selection.	4-3
7-1.	Control Switch Continuity Checks	7-3
10-1.	C-6280(P)/APX Group Assembly Parts List.	10-5
10-2.	C-6280A(P)/APX Group Assembly Parts List.	10-7
10-3.	C-6717/APX and C-7483/APX Group Assembly Parts List.	10-9
104.	Switch Assembly Group Assembly Parts List	10-11
10-5.	Numerical Index	10-13
10-6.	Reference Designation Index	10-15

T.O. 12P4-2APX-142
NAVAIR 16-35C6280-1
TM 11-5841-268-25

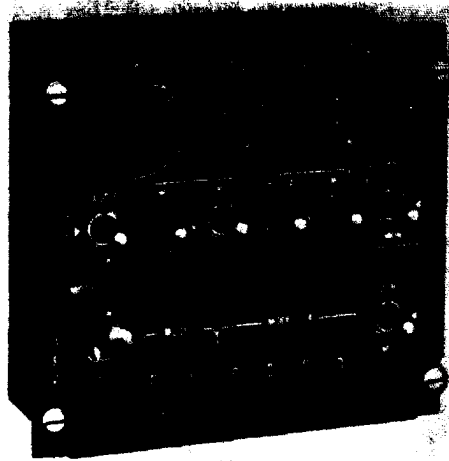

CONTROL, TRANSPONDER SET C-6280(P)/APX

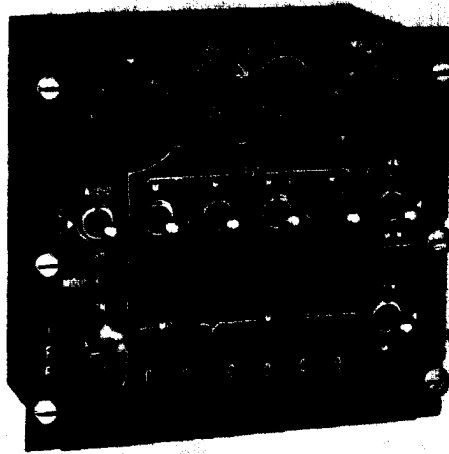

CONTROL, TRANSPONDER SET C-6280A(P)/APX

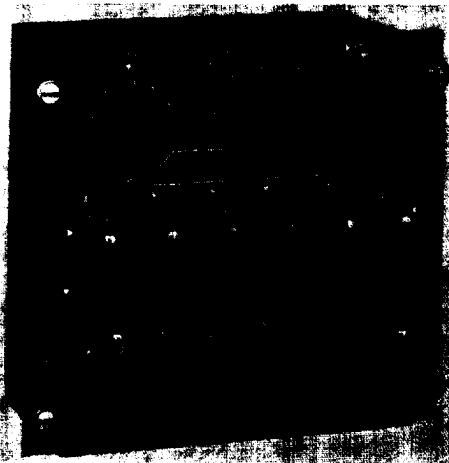

**CONTROL, TRANSPONDER SET C-6717/APX
and
CONTROL, TRANSPONDER SET C-7483/APX**

Figure 1-1. Control, Transponder Set C-6280(P)/APX, C-6280A(P)/APX, C-6717/APX, and C-7483/APX

SECTION I

DESCRIPTION AND LEADING PARTICULARS

NOTE

This technical manual and the prime equipment covered herein is configured for interservice use and maintainability by direction of the Department of Defense AIMS System Program Office (DOD AIMS SPO). No changes shall be made to the equipment or the technical manual without the approval of the DOD AIMS SPO.

1-1. GENERAL.

1-2. This publication contains descriptive and maintenance information for Control, Transponder Set C-6280(P)/APX, C-6280A(P)/APX, C-6717/APX, and C-7483/APX. These units were manufactured under the following contracts:

Contract	Type	Manufacturer
AF33(657)-14550	C-6280(P)/APX	Admiral
AF33(657)-14550	C-6280A(P)/APX	Admiral
AF33(657)-14550	C-6717/APX	Admiral
AF33(657)-16648	C-6280(P)/APX	Aircraft Radio
AF33(657)-16648	C-6280A(P)/APX	Aircraft Radio
F33657-68-C-0785	C-6717/APX	Aircraft Radio
F33657-68-C-0785	C-7483/APX	Aircraft Radio

NOTE

Unless defined by type number, the information in this manual is applicable to all the transponder set controls listed. Also, the use of the common name "transponder set control" refers to all units.

1-3. This manual contains information for organizational, field, intermediate, direct and general support, and depot maintenance, and an illustrated parts breakdown, for the transponder set controls listed in paragraph 1-2. It includes instructions appropriate to direct and general support and depot for troubleshooting, testing, and repairing the equipment, and replacing maintenance parts. It also lists tools, materials, and test equipment for direct and general support and depot maintenance. Detailed functions of the equipment are discussed in Section IV.

1-4. Except for Serial No. 1 through 3322 of Control, Transponder Set C4280(P)/APX, manufactured under Contract AF33(657)-14550, the information in this manual is applicable to all the transponder set controls listed in paragraph 1-2. When these transponder set controls have been modified in accordance with T.C.T.O. 12P4-2APX-508 or AVC-900, the information in this manual also applies to them. The modification consists of the replacement of the

MASTER switch and making related wiring changes. The replacement switch has a detent mechanism which requires the knob to be pulled out before the switch can be set to OFF or EMER positions. Beginning with Serial No. 3323 of Contract AF33(657)-14450, the modification was incorporated during production.

1-5. INDEXES OF PUBLICATIONS.

1-6. Refer to the latest issue of (*Air Force*) T.O. 0-1-12, (*Navy*) NAVSUP 2002, Section VIII, or (*Army*) DA Pam 310+ to determine whether there are new editions, changes, or additional publications pertaining to the equipment.

1-7. (*Army*) Refer to the latest issue of DA Pam 310-7 to determine whether there are modification work orders (MWOs) pertaining to the equipment.

1-8. FORMS AND RECORDS.

1-9. REPORTS OF MAINTENANCE AND UNSATISFACTORY EQUIPMENT. Use equipment forms and records in accordance with instructions in (*Air Force*) AFTO Form 29/29A, (*Navy*) NAVWEPS Form 13070/5, or (*Army*) TM 38-750.

1-10. REPORT OF PACKAGING AND HANDLING DEFICIENCIES. Fill out and forward DD Form 6 (Report of Packaging and Handling Deficiencies) as prescribed in (*Air Force*) AFR 714, (*Navy*) NAVSUP Publication 378, or (*Army*) AR 700-58.

1-11. DISCREPANCY IN SHIPMENT REPORT (DISREP) (SF 361). Fill out and forward Discrepancy in Shipment Report (DISREP) (SF 361) as prescribed in (*Air Force*) AFM 75-34, (*Navy*) NAVSUP Publication 459, or (*Army*) AR 55-38.

1-12. REPORTING OF IMPROVEMENTS FOR EQUIPMENT MANUALS. Reporting of errors, omissions, and recommendations for improving this publication by the individual user is encouraged. Reports should be submitted on (*Air Force*) AFTO Form 22, (*Navy*) NAVWEPS Form 13070/5, or (*Army*) DA Form 2028. DA Form 2028 will be forwarded direct to Commanding General, U.S. Army Electronics Command, ATTN: AMSEL-ME-NMP-AD, Fort Monmouth, New Jersey 07703.

1-13. PURPOSE OF EQUIPMENT.

1-14. All the transponder set controls perform the same function. They are designed as a universal control for the various IFF/SIF transponders used in aircraft configurations. Each unit provides the operating controls and indications

T.O. 12P4-2APX-142
 NAVAIR 16-35C6280-1
 TM 11-5841-268-25

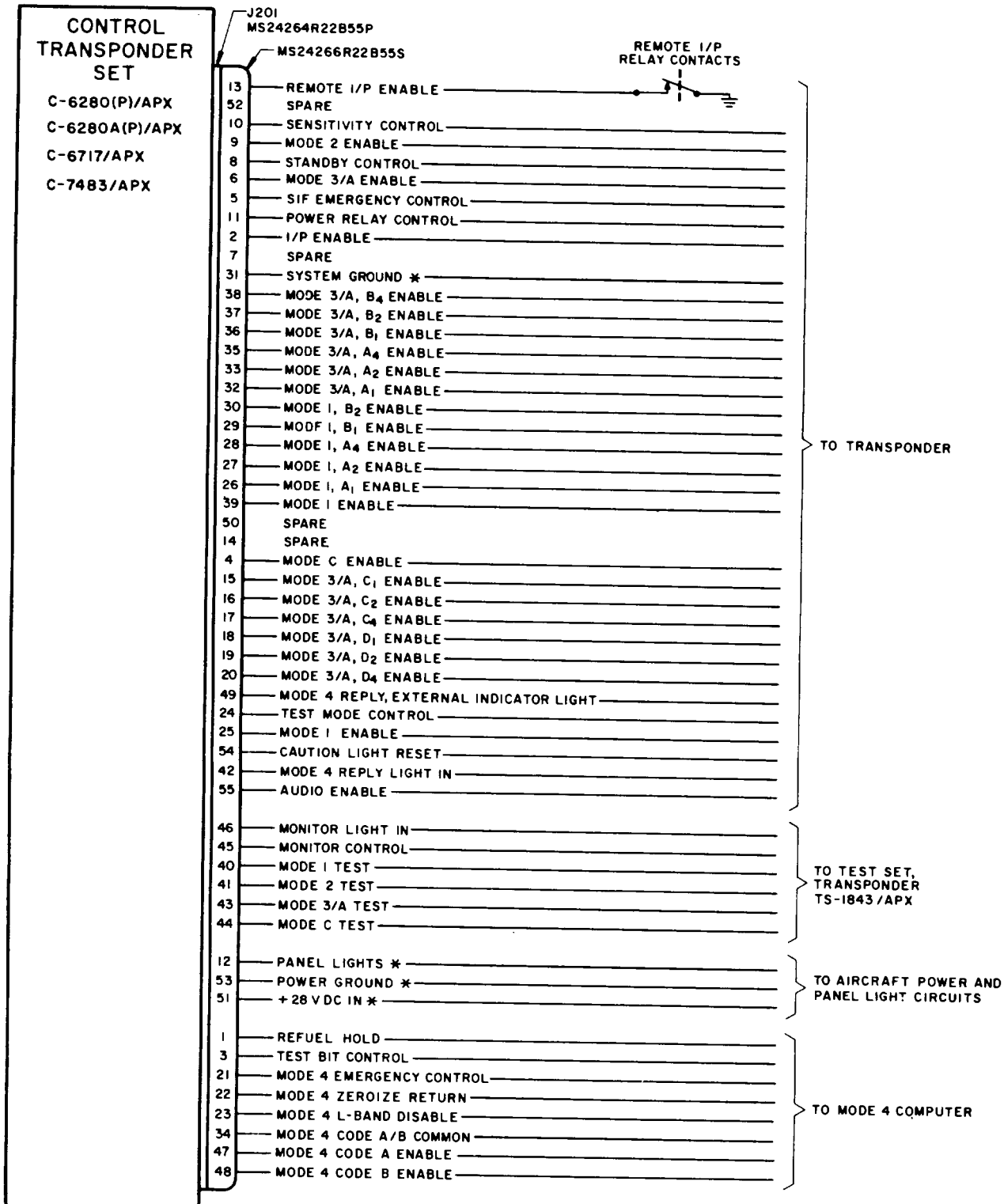

NOTES:

1. All wires are stranded copper, insulated. Unmarked wires are No. 22 AWG; those marked with an asterisk (*) are No. 16 AWG.
2. Wire lengths and terminating connectors depend on the requirements of the individual installation.

Figure 1-2. Control, Transponder Set C-6280(P)/APX, C-6280A(P)/APX, C-6717/APX, and C-7483/APX, External Wiring Diagram

required for pilot operation and monitoring of transponder systems with AIMS capabilities.

1-15. DESCRIPTION OF EQUIPMENT.

1 - 16. GENERAL. The transponder set controls, shown in Figure 1-1 and listed in paragraph 1-2, are essentially the same. The major differences are in the method and color of panel illumination (paragraphs 1-19 and 1-20) and the number of mounting fasteners (paragraph 1-17). Except for the differences in input voltage required for panel lighting, and the C-6280A(P)/APX which uses six turnlock fasteners for installation, the units are interchangeable. Each unit measures 5.75 x 5.25 x 3.09 inches and weighs approximately 2.75 pounds. Two knob-actuated rotary switches, eight toggle switches, and two press-to-test indicator lights are mounted on the panel. The functions of these controls and indicators are described in Table 1-1. No electron tubes, semiconductor devices, resistors, capacitors, or inductors are used.

1-17. INSTALLATION. The transponder set control is designed for installation in a standard aircraft control panel and is equipped with turnlock fasteners for easy installation and removal. The C-6280(P)/APX, C-6717/APX, and C-7483/APX are each equipped with four turnlock fasteners while the C-6280A(P)/APX is equipped with six turnlock fasteners. The unit is installed in a position that is accessible to the operator. Electrical connections are made through a 55-pin connector on the rear of the unit. The transponder set control is connected to the other units of the transponder system through this connector and associated aircraft wiring. External wiring for a typical installation of the transponder set control is shown in Figure 1-2.

1-18. PANEL ILLUMINATION. The markings on the plastic panel of the transponder set control are illuminated from behind and glow with a red, white, or blue-white light. The light is also used to illuminate the numerals on the thumbwheel switch knobs and the lettering on the rotary switch dials.

1-19. On the C-6280(P)/APX and the C-6280A(P)/APX, the light is provided by five replaceable incandescent lamps. The color of the light is determined by the color of the falter in the panel light holder. Since the transponder set control is designed for use in various aircraft which may have different panel lighting requirements, it is supplied with panel light holders with blue-white, red, or clear falter and either 6- or 28-volt lamps. The units can be converted for a different panel lighting requirement by changing the lamps and holders. A two-letter category, which is stamped on the packing carton, has been assigned to indicate how the unit has been equipped. These categories are: A, 6-volt lamps; B, 28-volt lamps; C, blue-white falter; D, red falter; and E, clear falter.

1-20. On the C-6717/APX and the C-7483/APX, the panel

markings are illuminated by 21 miniature lamps embedded in the plastic panel. These lamps are not replaceable. *Input voltage applied to these lamps must not exceed 5 volts DC.* The panel of the C-6717/APX is red-lighted and that of the C-7483/APX is white-lighted.

1 -21. MASTER SWITCH. The MASTER switch is a five-position rotary switch. In addition to turning the transponder set on or off, this switch controls the sensitivity of the transponder receiver and provides for emergency reply operation. To prevent accidentally switching to the emergency (EMER) or the OFF position, the switch knob must be pulled out before the switch can be turned to either of these positions.

1 -22. OPERATING MODE SELECTION. The transponder set control includes four mode-enabling switches which are used to select the operating mode of the transponder set. These are three-position toggle switches which, besides the ON and OUT (off) positions, also include a momentary position for test signal selection.

1-23. REPLY CODE SELECTION. The transponder set control includes separate groups of thumbwheel switches for selecting the codes for Mode 1 and Mode 3/A replies. Code selection controls for Mode 2 replies are usually located on one of the other units of the transponder set. Two switches are used for Mode 1 and four are used for Mode 3/A. All switches include indication knobs which in combination digitally display the selected code number.

1-24. IDENTIFIER PULSE SELECTION. The transponder set control includes a three-position toggle switch for identifier pulse selection. The identifier pulse is selected when the switch is held in the momentary IDENT position. With the switch set to the MIC position, the identifier pulse is selected when the microphone keying switch (not part of the transponder set control) is closed.

1-25. TEST PROVISIONS. A three-position toggle switch on the transponder set control is used to select transponder test operation. When Transponder Test Set TS-1843()/APX is included in the installation, the MON position of the switch turns on the monitoring circuits of the test set. The RAD TEST position of the switch is used to enable an appropriately equipped transponder set to reply to TEST mode interrogations from an AN/APM-123(V)() or similar equipment.

1-26. Each of the four mode-enabling toggle switches on the transponder set control includes a momentary TEST position. The TEST position, when selected, allows a locally-generated interrogation signal from the transponder monitor (such as Transponder Test Set TS-1843()/APX) to be applied to the transponder set. Transponder set replies to the test signal are indicated by the TEST indicator light.

1-27. MODE 4 CONTROLS. The controls and indicator for Mode 4 operation are grouped together along the left side of the control panel. A MODE 4 ON-OUT toggle switch is

T.O. 12P4-2APX-142
NAVAIR 16-35C6280-I
TM 11-5841-268-25

used to enable the transponder set to process Mode 4 inter-rogations. The handle of this switch is designed to permit recognition by touch. Also, to prevent accidental setting of the switch to OUT, the handle must be pulled outward before it can be lowered to the OUT position. A three-position toggle switch selects Mode 4 monitoring and the monitoring method. The AUDIO position selects both audio and reply-light monitoring; the LIGHT position selects reply-light monitoring only; and the OUT position turns off the monitoring circuits. A knob-actuated rotary switch is used for Mode 4 CODE selection. To prevent the control from being accidentally set to the ZERO position, the knob must be pulled out before the switch can be turned to ZERO. The switch also includes a spring-return which automatically returns the switch and knob to the A position from the HOLD position.

1-28. INDICATOR LIGHTS. Both the TEST and REPLY indicator lights are press-to-test types. Operation of the lamps can be checked by pressing the cap in and observing that the lamp lights. Also, the light may be dimmed by turning the cap clockwise. The TEST light is associated with the transponder set test circuits, while the REPLY light is part of the Mode 4 control circuits.

1-29. OPERATING CONTROLS AND INDICATORS.

1-30. The operating controls and indicators and their panel markings, shown in Figure 1-3, are the same on all the transponder set controls. The functions of these controls and indicators are described in Table 1-1.

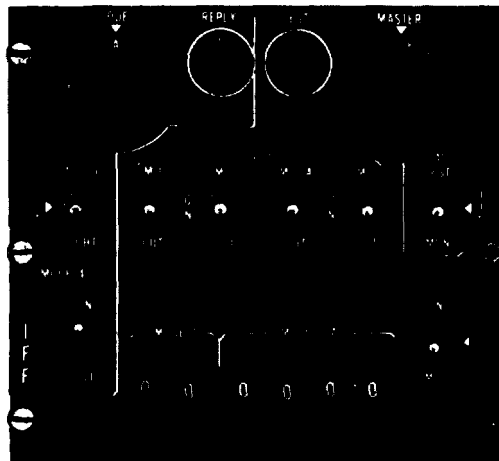

Figure 1-3. Operating Controls and Indicators

TABLE 1-1. OPERATING CONTROLS AND INDICATORS

CONTROL OR INDICATOR	FUNCTION
MASTER Switch	Turns transponder set on and off, selects receiver sensitivity, and selects emergency operation: OFF Removes power from transponder set and transponder computer. STBY Enables transponder receiver and computer; disables transponder transmitter. LOW Places transponder set in operation at reduced receiver sensitivity. NORM Places transponder set in operation at normal receiver sensitivity. EMER Causes automatic transmission of emergency reply signals to Mode 1, 2, or 3/A interrogations only, regardless of mode switch settings (not affected by Mode C or 4 interrogations).
M-1 Switch	ON position selects Mode 1 operation of transponder set; TEST position selects Mode 1 test operation; OUT position turns off Mode 1 operation.
M-2 Switch	ON position selects Mode 2 operation of transponder set; TEST position selects Mode 2 test operation; OUT position turns off Mode 2 operation.
M-3/A Switch	ON position selects Mode 3/A operation of transponder set; TEST position selects Mode 3/a test operation; OUT position turns off Mode 3/A operation.
M-C Switch	ON position selects Mode C operation of transponder set; TEST position selects Mode C test operation; OUT position turns off Mode C operation.
MODE 1 Reply-code Selector Switches (2)	Select and indicate Mode 1 two-digit reply code number.
MODE 3/A Reply-code Selector Switches (4)	Select and indicate Mode 3/A four-digit reply code number.
IDENT-OUT-MIC Switch	IDENT position selects identifier pulse; MIC position permits selection of identifier pulse when microphone keying switch is closed; OUT position turns off identifier pulse circuit.

TABLE 1-1. OPERATING CONTROLS AND INDICATORS—Continued

<i>CONTROL OR INDICATOR</i>	<i>FUNCTION</i>
RAD TEST-OUT-MON Switch	Selects test signals: RAD TEST position permits transponder set to be interrogated by selected Mode signals from an AN/APM-123(V)() or similar equipment; MON position turns on the monitoring circuits of Transponder Test Set TS-1843()/APX; OUT position disables test circuits.
TEST Light	Lamp lights when transponder set responds properly to Mode 1, 2, 3/A, or C test signal.
MODE 4 CODE Switch	Selects type of Mode 4 operation: HOLD When held in position, overrides zeroizing function and enables transponder computer to retain Mode 4 code settings when AC power is removed. When released, returns to A position. A Enables transponder system to respond to Code A interrogations. B Enables transponder system to respond to Code B interrogations. ZERO Cancels (zeroizes) Mode 4 code settings from transponder computer provided other operational requirements are met.
MODE 4 ON-OUT Switch	ON Enables transponder system to reply to Mode 4 interrogations. OUT Disables Mode 4 operation.
MODE 4 AUDIO-OUT-LIGHT Switch	Selects Mode 4 monitoring method: AUDIO Enables aural monitoring (short burst 300 to 400 cycle buzz) of Mode 4 interrogations (valid or invalid) and REPLY light monitoring of Mode 4 replies. LIGHT Enables only REPLY light monitoring of Mode 4 replies. OUT Disables aural and REPLY light monitoring.
MODE 4 REPLY Light	Lights to indicate valid Mode 4 replies when MODE 4 AUDIO-LIGHT-OUT switch is set to either AUDIO or LIGHT.

SECTION II PREPARATION FOR MAINTENANCE

(Not Applicable)

SECTION III TEST EQUIPMENT AND SPECIAL TOOLS

3-1. TEST EQUIPMENT REQUIRED.

3-2. The following test equipment is required for maintenance of Control, Transponder Set C-6280(P)/APX, C-6280A(P)/APX, C-6717/APX, and C-7483/APX:

(Air Force, Navy) Multimeter AN/PSM-6, or equivalent, for making continuity checks.

(Army) Multimeter ME-26/U, or equivalent, for making continuity checks.

Connector MS24266R22B55S, to facilitate checks.

3-3. TOOLS REQUIRED.

3-4. Except for the special tools listed in this paragraph, only common types of tools are required for maintenance of the transponder set controls. (Army) See Appendix C for Maintenance Allocation and Tools and Equipment List. The following tools, or their equivalent, are required for extracting and replacing contact pins in the electrical connector: Extraction Tool MS24256R20, or equivalent; Insertion Tool MS24256A20, or equivalent; and Crimping Tool M1700A

with MS3190 Head, or equivalent. In addition, the tool as shown in Figure 3-1 may be fabricated and used for holding the momentary test switches depressed, when necessary, during testing.

3-5. TEST WIRING.

3-6. Test wiring to facilitate measurements between contact pins of the electrical connector on the transponder set control may be fabricated by connecting a short length of wire to each contact of the MS24266R22B55S connector. These wires should be identified with the contact designation and attached to a bank of terminals suitable for making positive connections.

3-7. POWER SOURCE.

3-8. Other than voltage for checking the TEST and REPLY indicator lights and for lighting the panel lamps, the transponder set control requires no input power. A 28-volt DC source is required for checking the indicator lights. Depending on the particular transponder set control, a 5-volt, 6-volt, or 28-volt DC source is required for panel lighting. The C-6280(P)/APX and the C-6280A(P)/APX require either the 6-volt or 28-volt DC source, depending on the voltage rating of the panel lamps installed. The C-6717/APX and C-7483/APX require the 5-volt DC source.

T.O. 12P4-2APX-142

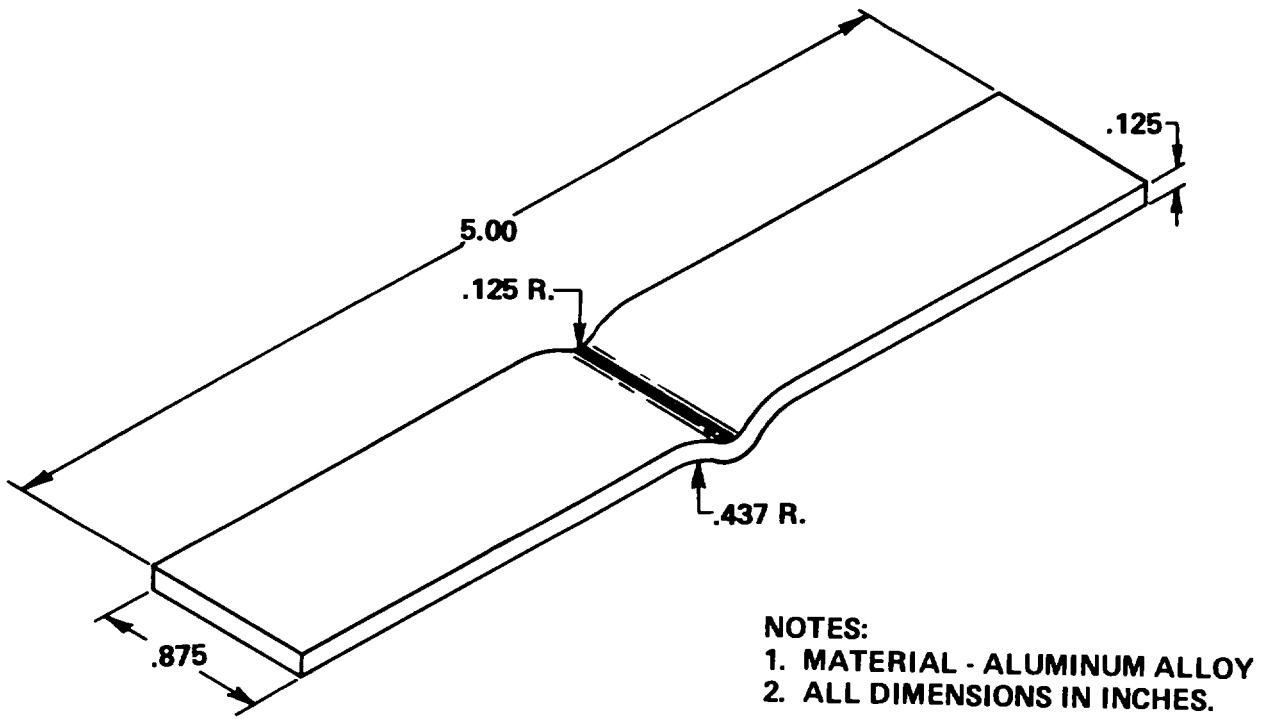

Figure 3-1. Momentary Switch Holding Tool - Fabrication.

SECTION IV

THEORY OF OPERATION

4-1. INTRODUCTION.

4-2. A general description of the transponder set control and its operating controls and indicators is included in Section I. Except for the operation of the Mode 1 and Mode 3/A code selector switches, this information adequately describes the purpose and operation of the transponder set control. For additional information, the purpose and operation of the Mode 1 and Mode 3/A code selector switches are described in paragraphs 4-3 through 4-7.

4-3. CODE NUMBER SELECTION.

4-4. The setting of the code selector switches determines which information pulses are present in a transponder set reply to IFF/SIF interrogations. The presence or absence of these information pulses is used to convey flight information to the ground controller. From 1 to 12 pulses are selected for coded identification. Each of the 12 pulses has a permanent nomenclature and position in the reply pulse-train signal. The pulses are divided into four groups of three pulses identified as the A, B, C, and D groups. Each pulse within a group is assigned an identification number which frees its position in the reply-pulse train. The numbers used (1, 2, and 4) form a binary code in which their various sums give the maximum number of combinations, without repetition, for any three numbers. Any digit from 0 to 7 can be obtained within a pulse group; thus, any number between 0000 and 7777 using these digits can be selected for the transponder reply.

4-5. The digits of the assigned code number indicate the code groups to be used and the pulse coding within the group. Depending on the mode of operation, the assigned code is either a two-digit or a four-digit number. In a two

digit number, the “tens” number designates the A group, while the “units” number designates the B group. In a four-digit number, the “thousands” digit designates the A group, the “hundreds” digit the B group, the “tens” digit the C group, and the “units” digit the D group. Figure 4-1 shows the standard reply-code pulse trains for each of the four modes of operation.

4-6. The control inserts the selected code number into the transponder set encoding matrix by grounding appropriate circuits. Table 4-1 shows the pattern of “grounds” and “opens” provided by the two Mode 1 switches, while Table 4-2 shows the pattern of “grounds” and “opens” provided by the four Mode 3/A switches. The first column in each table identifies the switch by its reference designation (see the schematic diagram, FO-1*) and its code position. The second column specifies the connector pin associated with the circuit which is designated in the third (*Pulse Position Controlled*) column. The fourth column indicates which circuits are grounded for each switch position. In both tables, an “X” in the fourth column indicates that the lead is grounded.

4-7. As shown in Tables 4-1 and 4-2, all selector switches except the second Mode 1 selector (S212) go through the same sequential pattern of grounds. S212 provides only positions 0 through 3 (positions 4, 5, 6, and 7 are not used). The tables also show that while code numbers 1, 2, and 4 can be represented by a single pulse, code numbers 3, 5, 6, and 7 require combinations of two or three pulses. In these cases, the sums of the pulse values are equal to the desired code numbers.

*FO (Foldout) refers to foldout illustration pages which are arranged in sequence (for example FO-1, FO-2) and included at the end of this manual.

TABLE 4-1. MODE 1 CODE NUMBER SELECTION

<i>SWITCH</i>	<i>CONNECTOR PIN</i>	<i>PULSE POSITION CONTROLLED</i>	<i>SWITCH POSITION (X = GROUND)</i>							
			<i>0</i>	<i>1</i>	<i>2</i>	<i>3</i>	<i>4</i>	<i>5</i>	<i>6</i>	<i>7</i>
S211 (tens)	26	A1		X		X		X		X
	27	A2			X	X			X	X
	28	A4					X	X	X	X
S212 (units)	29	B1		X		X	(Not Applicable)			
	30	B2			X	X				

T.O. 12P4-2APX-142
 NAVAIR 16-35C6280-1
 TM 11-5841-268-25

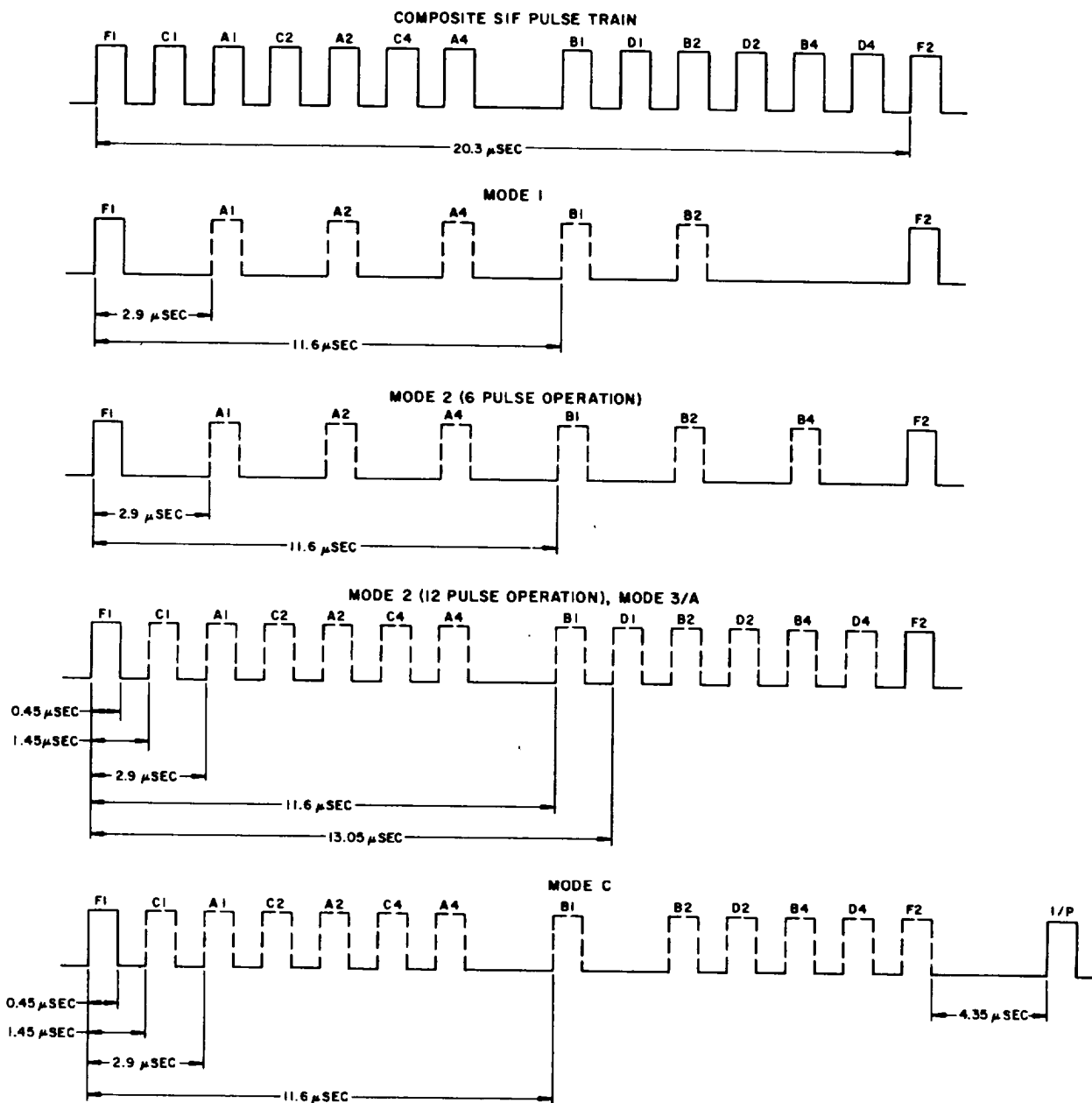

NOTES:

1. Position of pulses which may be used to establish reply codes are indicated by dotted lines.
2. No B4 pulse is used in Mode 1.
3. No D1 pulse is used in Mode C.

Figure 4- 1. IFF and SIF Reply Code Pulse Trains

TABLE 4-2. MODE 3/A CODE NUMBER SELECTION

SWITCH	CONNECTOR PIN	PULSE POSITION CONTROLLED	SWITCH POSITION (X = GROUND)							
			0	1	2	3	4	5	6	7
S213 (thousands)	32	A1		X		X		X		X
	33	A2			X	X			X	X
	35	A4					X	X	X	X
S214 (hundreds)	36	B1		X		X		X		X
	37	B2			X	X			X	X
	38	B4					X	X	X	X
S215 (tens)	15	C1		X		X		X		X
	16	C2			X	X			X	X
	17	C4					X	X	X	X
S216 (units)	18	D1		X		X		X		X
	19	D2			X	X			X	X
	20	D4					X	X	X	X

SECTION V
DESCRIPTION OF SYSTEM TIE-IN
OF EQUIPMENT AND ACCESSORIES

(Not Applicable)

SECTION VI
SYSTEM CHECK-OUT

(Not Applicable)

SECTION VII MAINTENANCE INSTRUCTIONS

7-1. GENERAL.

7-2. This section describes organizational, field, intermediate, direct and general support, and depot maintenance for servicing Control, Transponder Set C-6280(P)/APX, C-6280A(P)/APX, C-6717/APX, and C-7483/APX. It includes (*Army*) preventive maintenance procedures, preliminary inspection procedures, trouble location procedures, and repair information. Personnel should be familiar with the operation of the system in which the transponder set control is used in order to isolate the cause of malfunctions.

7-3. (*Army*) PREVENTIVE MAINTENANCE.

7-4. Preventive maintenance is the systematic care, servicing, and inspection of equipment to prevent the occurrence of trouble, to reduce out-of-service time, and to assure that the equipment is serviceable.

a. Systematic Care. The procedures given in this paragraph and paragraphs 7-5 through 7-12 cover routine systematic care and cleaning essential to proper upkeep and operation of the equipment.

b. Preventive Maintenance Checks and Services. The preventive maintenance checks and services charts (paragraphs 7-7 and 7-12) outline functions to be performed at specific intervals. These checks and services are to maintain Army electronic equipment in a serviceable condition; that is, in

good general (physical) condition and in good operating condition. To assist organizational maintenance repairmen in maintaining serviceability, the charts indicate what to check, how to check, and the normal conditions; the *References* column lists the paragraphs or technical manuals that contain detailed repair or replacement procedures. If the defect cannot be remedied by the organizational repairman, higher level maintenance is required. Records and reports of these checks must be made in accordance with TM 38-750.

7-5. (*Army*) INTERMEDIATE PREVENTIVE MAINTENANCE CHECKS AND SERVICES.

7-6. Perform the maintenance functions indicated in the intermediate preventive maintenance checks and services chart (paragraph 7-7) once each intermediate interval. An intermediate interval is defined as approximately 25 flying hours. The intermediate preventive maintenance checks and services should be performed concurrently with the intermediate preventive maintenance checks and services scheduled on the aircraft in which the equipment is installed. Adjustments of the maintenance interval must be made to compensate for any unusual operating conditions. Equipment maintained in a standby (ready for immediate operation) condition must have intermediate maintenance performed at least once every 30 days. Equipment in limited storage (requires service before operation) does not require intermediate maintenance.

7-7. (*Army*) INTERMEDIATE PREVENTIVE MAINTENANCE CHECKS AND SERVICES CHART

SEQUENCE NO.	ITEM	PROCEDURE	REFERENCES
1	Completeness	See that the equipment is complete.	—
2	Exterior Surfaces	<i>a.</i> Clean the transponder set control. <i>b.</i> Inspect exposed metal surfaces for rust, corrosion, and bare spots.	Paragraph 7-8 —
3	Intercabling and Connectors	Check all interconnecting cables for evidence of chafing, cracking, or excessive strain. Refer to higher level maintenance replacement. Check to see that cable connectors are clean, intact, and not loose fitting.	— —
4	Mounting	Check to see that the transponder set control is securely mounted.	—
5	Operating Controls	Check to see that the transponder set control operates normally.	—

T.O. 12P4-2APX-142
NAVAIR 16-35C6280-1
TM 11-5641-266-25

7-8. (Army) CLEANING.

7-9. Inspect the exterior of the transponder set control. The exterior surfaces should be clean, free of dust, dirt, grease, and fungus.

- a. Remove dust and loose dirt with a clean, soft cloth.

WARNING

THE FUMES OF TRICHLOROETHANE ARE TOXIC. PROVIDE THOROUGH VENTILATION WHEN EVER USED. DO NOT USE NEAR AN OPEN FLAME. TRICHLOROETHANE IS NOT FLAMMABLE, BUT EXPOSURE OF THE FUMES TO AN OPEN FLAME CONVERTS THE FUMES TO HIGHLY TOXIC, DANGEROUS GASES.

- b. Remove grease, fungus, and ground-in dirt from the case; use a cloth dampened (not wet) with trichloroethane.
- c. Remove dust and dirt from connectors with a brush.
- d. Remove rust and corrosion from metal surfaces by

lightly sanding them with fine sandpaper. Brush two thin coats of paint on the bare metal to protect it from further corrosion. Refer to applicable cleaning and refinishing practices specified in SB 11-573 and TB 746-10.

7-10. (Army) PERIODIC PREVENTIVE MAINTENANCE CHECKS AND SERVICES.

7- 11. In addition to the intermediate preventive maintenance checks and services, perform the maintenance functions indicated in the periodic maintenance checks and services chart (paragraph 7-12) once each periodic interval. Periodic preventive maintenance will be scheduled in accordance with the requirements of TM 38-750. To reduce out-of-service time, the periodic preventive inspection should be scheduled concurrently with the periodic maintenance service schedule of the aircraft in which the equipment is installed. Refer to the applicable aircraft technical manual for the hours between service periods. Equipment with a deficiency that cannot be remedied at the organizational level should be deadlined in accordance with TM 38-750.

7-12. (Army) PERIODIC PREVENTIVE MAINTENANCE CHECKS AND SERVICES CHART

SEQUENCE NO.	ITEM	PROCEDURE	REFERENCES
1	Exterior Surfaces	<ul style="list-style-type: none"> a. Clean the transponder set control. b. Clean and touch up painted surfaces that show bare spots, rust, and corrosion. 	<ul style="list-style-type: none"> a Paragraph 7-8 b. Paragraph 7-8
2	Publications	Check to see that all publications pertinent to this equipment are on hand, complete, serviceable, and current.	DA Pam 3104
3	Modification Work Orders	Check DA Pam 3104 to determine whether new applicable MWOs have been published. All URGENT MWOs must be applied immediately. All NORMAL MWOs must be scheduled.	TM 38-750 and DA Pam 3104

7-13. MALFUNCTION RECOGNITION.

7-14. When a malfunction occurs in the transponder system, it can usually be detected during operation or during routine checks. The MON position of the RAD-TEST-OUT-MON switch on the transponder set control turns on the monitoring circuits of Transponder Test Set TS- 1843()/APX, while each of the mode selector switches includes a TEST position which selects a test signal for the selected mode. Indication of proper operation is provided by the TEST light. The TEST and REPLY lights include a press-to-test circuit for testing the lamp itself.

7- 15. When a malfunction has been isolated to the transponder set control, the unit should be removed from the aircraft and tagged with a description of the trouble symptoms. The transponder set control should then be forwarded to the appropriate maintenance personnel.

7-16. PRELIMINARY INSPECTION.

7-17. When a defective transponder set control is received,

it should be given a preliminary inspection to determine the extent of physical or mechanical damage, if any:

- a. Examine front of unit for cracked or broken plastic panel, loose or broken knobs, and scratches in the panel . plastic and paint. On the C-6280(P)/APX and the C-6280A (P)/APX, check that all panel light holders are complete and are firmly seated in the mounting bases.

- b. Check electrical connector for bent or broken pins.

- c. Loosen the two turnlock fasteners on the back of the unit and remove dust cover. Visually check the inside of the unit for broken or frayed wires, loose connections, broken switch sections, or other obvious damage.

7-18. TROUBLE LOCATION.

7-19. To verify and isolate a reported malfunction, and to assure, after repair, that all controls and indicators are functioning properly, perform the trouble location checks described in paragraphs 7-20 through 7-26. When the results

indicated cannot be obtained, the trouble is isolated to the specific circuit being tested.

7-20. PANEL LIGHT CHECK.

CAUTION

Do not apply a voltage greater than 5 volts to the panel light circuit of the C-6717/APX or the C-7483/APX. If the panel lamps are burned out, the entire plastic panel must be replaced.

7-21. For all transponder set controls, voltage for the panel light circuit is applied through pins 12 and 53 of J201; however, *the voltage required varies with the transponder set control type* (refer to paragraphs 1-19 and 1-20). The C-6280(P)/APX and the C-6280A(P)/APX may be equipped with either 6-volt or 28-volt panel lamps. Since these lamps are directly interchangeable, determine the voltage rating of the lamps installed in the unit being tested. For all the transponder set controls, connect the positive lead of the appropriate voltage supply to pin 12 of J201 and connect the negative lead to pin 53. Check that all panel lamps light.

7-22. INDICATOR LIGHT CHECK.

7-23. TEST INDICATOR LIGHT. To check TEST indicator light DS202, turn the lens cap fully counterclockwise to open dimmer. On J201, connect positive lead of 28-volt DC power supply to pin 51 and connect negative lead to pin 31. Press lens cap in (press-to-test) and check that lamp lights. Release cap, and connect positive lead of power supply to pin 46 of J201; lamp should light. Disconnect power supply.

7-24. MODE 4 REPLY INDICATOR LIGHT. To check MODE 4 REPLY indicator light DS201, turn lens cap fully counterclockwise to open dimmer. Set AUDIO-OUT-LIGHT switch to AUDIO or LIGHT (lamp will not operate if switch is in OUT position). On J201, connect positive lead of 28-volt DC power supply to pin 51 and connect negative lead to pin 31. Press lens cap in (press-to-test) and check that lamp lights. Release cap, and connect positive lead of power supply to pin 42 of J201; lamp should light. Disconnect power supply.

7-25. CONTROL SWITCH CHECK.

7-26. The control switches and their circuits are tested by making the continuity checks listed in Table 7-1. Use the multimeter listed in paragraph 3-2 and the test wiring described in paragraph 3-5. Set the multimeter to indicate continuity and connect the leads to the specified pins of J201. When the multimeter indications listed are not obtained, the malfunction is immediately isolated to the circuit under test. It is not necessary to follow the order of checks as listed; any switch function may be checked individually, as required. When making the continuity checks, unless otherwise instructed, all toggle switches are set to the OFF or OUT position, the MASTER switch is set to any position except EMER, and the CODE switch is set to any position. To aid in understanding the significance of the various switch settings and the resulting indications, refer to the schematic diagram (FO-1) and the wiring diagram (FO-2).

TABLE 7-1. CONTROL SWITCH CONTINUITY CHECKS

CONTROL	SWITCH SETTING	J201 PINS		MULTIMETER INDICATION	
		FROM	TO	OPEN	SHORT
Grounds	—	53 Chassis	31 31		X X
MASTER Switch S202	OFF	6 11 5 10 25 23 39 21 8 9 4	} 31	X X X X X X X X X X	

T.O. 12P4-2APX-142
 NAVAIR 16-35C6280-1
 TM 11-5841-268-25

TABLE 7-1. CONTROL SWITCH CONTINUITY CHECKS—continued

CONTROL	SWITCH SETTING	J201 PINS		MULTIMETER INDICATION	
		FROM	TO	OPEN	SHORT
MASTER Switch S202 (Continued)	STBY	6	} 31	X	
		11			X
		5			X
		10			
		25			X
		23			
		39			
		21			X
		8			X
		9			X
		4			X
		LOW		6	} 31
	11			X	
	5			X	
	10			X	
	25			X	
	23				
	39				
	21			X	
	8				
	9			X	
	4			X	
	NORM		6	} 31	
		11			X
		5			
		10			X
		25			
		23			X
		39			X
		21			X
		8			
		9			X
		4			X
		EMER	6		} 31
	11			X	
	5			X	
10			X		
25			X		
23					
39			X		
21					
8					
9					
4					
8	21			X	

TABLE 7-1. CONTROL SWITCH CONTINUITY CHECKS—Continued

CONTROL	SWITCH SETTING	J201 PINS		MULTIMETER INDICATION	
		FROM	TO	OPEN	SHORT
MODE 4 CODE Switch S201	HOLD	22	} 31		X
		34		X	
		47		X	
		48		X	
		1			X
		34	47	X	
	A	22	31		X
		1	31	X	
		34	47		X
		48	34	X	
	B	1	31	X	
		22	31		X
		34	47	X	
		48	34		X
	ZERO	1	31	X	
		22	31	X	
34		47	X		
48		34	X		
MODE 1 Reply-code Selector Switches S211, S212	00	28	} 31	X	
		27		X	
		26		X	
		30		X	
		29		X	
	11	28	} 31	X	
		27		X	
		26			X
		30		X	
		29			X
	22	28	} 31	X	
		27		X	
		26			X
		30		X	
		29			X
	33	28	} 31	X	
		27			X
		26			X
		30			X
		29			X
	40	28	31		X
		27	31	X	
		26	31	X	
	50	28	31		X
27		31	X		
26		31		X	
60	28	31		X	
	27	31		X	
	26	31	X		
70	28	31		X	
	27	31		X	
	26	31		X	

T.O. 12P4-2APX-142
 NAVAIR 16-35C6280-1
 TM 11-5641-268-25

TABLE 7-1. CONTROL SWITCH CONTINUITY CHECKS-Continued

CONTROL	SWITCH SETTING	J201 PINS		MULTIMETER INDICATION				
		FROM	TO	OPEN	SHORT			
MODE 3/A Reply-code Selector Switches S213, S214, S215, S216	7777	35	} 31		X			
		33		X				
		32		X				
		38		X				
		37		X				
		36		X				
		17		X				
		16		X				
		15		X				
		20		X				
		19		X				
		18		X				
		0000		0000	35	} 31	X	
					33		X	
					32		X	
					38		X	
37	X							
36	X							
17	X							
16	X							
15	X							
20	X							
19	X							
18	X							
1111	1111		35		} 31		X	
			33				X	
			32					X
			38				X	
		37	X					
		36		X				
		17	X					
		16	X					
		15		X				
		20	X					
		19	X					
		18		X				
		2222	2222	35		} 31	X	
				33				X
				32			X	
				38			X	
37				X				
36	X							
17	X							
16				X				
15	X							
20	X							
19				X				
18	X							

TABLE 7-1. CONTROL SWITCH CONTINUITY CHECKS—Continued

CONTROL	SWITCH SETTING	J201 PINS		MULTIMETER INDICATION		
		FROM	TO	OPEN	SHORT	
MODE 3/A Reply-code Selector Switches S213, S214, S215, S216 (Continued)	3333	35	} 31	X		
		33			X	
		32			X	
		38		X		
		37			X	
		36			X	
		17			X	
		16			X	
		15			X	
		20		X		
		19			X	
		18			X	
	4444	4444	35	} 31		X
			33		X	
			32		X	
			38			X
			37		X	
			36		X	
			17			X
			16		X	
			15		X	
			20			X
			19		X	
			18		X	
	5555	5555	35	} 31	X	X
			33		X	X
			32			X
			38			X
			37		X	
			36			X
			17			X
			16		X	
			15			X
			20			X
			19		X	
			18			X
6666	6666	35	} 31		X	
		33			X	
		32		X		
		38			X	
		37			X	
		36		X		
		17			X	
		16			X	
		15		X		
		20			X	
		19			X	
		18		X		

T.O. 12P4-2APX-142
 NAVAIR 16-35C6280-1
 TM 11-5841-268-25

TABLE 7-1. CONTROL SWITCH CONTINUITY CHECKS—Continued

CONTROL	SWITCH SETTING	J201 PINS		MULTIMETER INDICATION		
		FROM	TO	OPEN	SHORT	
M-1 Mode Selector Switch S205	OUT	25	31	X		
		40	31	X		
	ON	25	31		X	
		40	31	X		
	TEST	25	31		X	
		40	31		X	
M-2 Mode Selector Switch S206	OUT	9	31	X		
		41	31	X		
	ON	9	31		X	
		41	31	X		
	TEST	9	31		X	
		41	31		X	
M-3/A Mode Selector Switch S207	OUT	6	31	X		
		43	31	X		
	ON	6	31		X	
		43	31	X		
	TEST	6	31		X	
		43	31		X	
M-C Mode Selector Switch S208	OUT	4	31	X		
		44	31	X		
	ON	4	31		X	
		44	31	X		
	TEST	4	31		X	
		44	31		X	
IDENT-OUT-MIC Switch S210	OUT	2	31	X		
		2	13	X		
	IDENT	2	13	X		
		2	31		X	
	MIC	2	31	X		
		2	13		X	
RAD TEST-OUT-MON Switch S209	OUT	45	31	X		
		24	31	X		
		3	31	X		
	RAD TEST	45	31	X		
		24	31		X	
		3	31		X	
	MON	45	31		X	
		24	31	X		
		3	31	X		
	MODE 4 ON-OUT Switch S203 (MASTER Switch S202 set to STBY)	OUT	23	31		X
		ON	23	31	X	
	MODE 4 AUDIO-OUT-LIGHT Switch S204	OUT	54	31	X	
55			31	X		
AUDIO		54	31		X	
		55	31		X	
LIGHT		54	31		X	
		55	31	X		

SECTION VIII

REPAIR AND OVERHAUL INSTRUCTIONS

8-1. GENERAL.

8-2. This section describes the procedures for repairing and overhauling Control, Transponder Set C-6280(P)/APX, C-6280A(P)/APX, C-6717/APX, and C-7483/APX. Unless otherwise indicated, the procedures apply to all the transponder set controls. The disassembly and reassembly procedures are keyed to the exploded views, FO-3, FO-4, and FO-5. (*Air Force, Navy*) For complete part identification, refer to the parts lists in Section X, which are also keyed to the exploded views. (*Army*) Refer to TM 11-5841-268-25P for parts identification.

8-3. REPLACEMENT OF PLASTIC LIGHT PANEL.

8-4. To remove and replace the plastic light panel, proceed as follows:

Step 1. Loosen setscrews (6 and 8, FO-3, FO-4, FO-5) in control dials (5 and 7) and remove control dials. "

Step 2. Center all toggle switch handles.

Step 3. On C-6280(P)/APX and C45280A(P)/APX, unscrew and remove five panel light holders (9, FO-3, FO-4).

Step 4. On C-6280(P)/APX, C-6717/APX, and C-74831 APX, remove four screws (12, FO-3; 10, FO-5). On C-6280 A(P)/APX, remove four screws (12, FO-4), nuts (13), and washers (14).

Step 5. On C-6717/APX and C-7483/APX, disconnect P201 (part of light panel) from connector J202 (45, FO-5).

Step 6. Gently lift off light panel (11, FO-3, FO-4; 9, FO-5).

Step 7. To install light panel, reverse procedures in Steps 1 through 6.

8-5. REMOVAL AND REPLACEMENT OF REAR PANEL ASSEMBLY.

8-6. To remove and replace the rear panel assembly, proceed as follows:

Step 1. Loosen two turnlock fasteners on rear of unit and remove dust cover (1, FO-3, FO-4, FO-5).

Step 2. Remove four screws and washers (18 and 19, FO-3; 20 and 21, FO-4; 17 and 18, FO-5). On C-6280A (P)/APX, also remove two screws (26, FO-4). Move panel assembly (17, FO-3; 19, FO-4; 16, FO-5) away from chassis.

Step 3. On C-6280(P)/APX, C-6717/APX, and C-7483/APX, remove four screws, nuts, and washers (24, 25, 26, FO-3; 23, 24, 25, FO-5). On C-6280A(P)/APX, remove

two screws, nuts, and washers (27, 28, 29, FO-4). Remove panel assembly.

Step 4. When repair or replacement has been completed, reverse the procedures in Steps 1, 2, and 3 to reassemble rear panel assembly.

8-7. REPAIR AND REPLACEMENT OF CONNECTOR J201.

8-8. GENERAL. When any of the contact pins or the contact receptacle of J201 (23, FO-3; 25, FO-4; 22, FO-5) has been damaged, the connector should be repaired or replaced as outlined in paragraphs 8-9 through 8-12. When one or more pins are replaced, the wire or wires must be connected to the pins as described in paragraph 8-10. To provide access to the connector and wires, remove the rear panel assembly (paragraph 8-6). Replace the rear panel assembly when the repair or replacement has been completed.

8-9. CONTACT PIN REMOVAL. With connector J201 accessible (paragraph 8-6), use extraction tool MS24256R20, or equivalent, and remove contact pin as follows:

Step 1. Set spacer sleeve of tool for removal of male contacts.

Step 2. Place tool over pin and insert tool into pin cavity, taking care not to damage pin or connector insert.

Step 3. Exert a moderate force (from 5 to 10 pounds) axially to tool to release retention collet. (Spacer sleeve should shoulder at face of insulation when tool is inserted to proper depth.)

Step 4. Push extraction plunger of tool so that pin is moved to rear of insert.

Step 5. Grasp pin or wire at rear face of insert and pull out pin.

Step 6. Remove extraction tool from connector and set spacer sleeve of the tool forward in the last notch to protect the end of the plunger guide.

8-10. CONNECTION OF WIRE TO CONTACT PIN. When a pin has been damaged, remove pin (paragraph 8-9) and loosen crimp with pliers to remove wire. When a wire is broken or damaged, strip insulation 3/16-inch from end of wire (avoid nicking the wire or damaging the insulation). Use crimping tool M1700A with MS3190 head, or equivalent, to crimp the new pin to the wire.

8-11. CONTACT PIN INSERTION. To insert contact pins in J201, use insertion tool MS24256A20, or equivalent, and proceed as follows:

T.O. 12P4-2APX-142
NAVAIR 16-35C6280-1
TM 11-5841-268-25

Step 1. Make sure wire is securely connected to contact pin.

Step 2. Lubricate wire cavities in back face of connector insert with a thin film of DC-200 Silicone Oil, or equivalent.

Step 3. Locate pin in insertion tool coaxially with tool.

Step 4. Align contact pin with appropriate hole in rear face of insert, taking care to avoid damaging the insert.

Step 5. When pin has entered rear seal portion of insert, maintain alignment of pin and tool parallel to and coaxially with the contact pin hole in the insert.

Step 6. Insert contact pin to full depth. (Insertion force is less than 5 pounds.) The seating of the contact pin in the retention collet should produce an audible sound.

Step 7. Keep insertion tool aligned with insert hole, and remove tool from connector.

8-12. REPLACEMENT OF CONNECTOR J201. When the connector mounting flange or the silicone-rubber insert of the connector is damaged, the connector must be replaced. Either the original contact pins may be reused or new pins may be installed. Replace the connector as follows:

Step 1. Remove all contact pins from connector (paragraph 8-9).

Step 2. If new contact pins are to be installed, disconnect wires from old pins and attach them to the new pins (paragraph 8-10).

Step 3. See wiring diagram FO-2 for wire colors and insert pins in the new connector insert (paragraph 8-11) according to wire color.

8-13. REPLACEMENT OF TOGGLE SWITCHES.

8-14. To remove and replace any of the eight toggle switches (41, 42, 43, 44, 45, FO-3; 51, 52, 53, 54, 55, FO-4; 40, 41, 42, 43, 44, FO-5), remove the plastic light panel (paragraph 8-3) and the rear panel assembly (paragraph 8-5). Then, proceed as follows:

Step 1. Unsolder wires from switch to be replaced.

Step 2. On subassembly mounting panel (59, FO-3; 65, FO-4; 61, FO-5), remove mounting nut and washer from toggle switch and remove switch.

Step 3. Install replacement switch on subassembly mounting panel with nut and washer.

Step 4. See wiring diagram FO-2, and solder appropriate wires to switch terminals.

Step 5. Replace the plastic light panel and rear panel assembly (paragraphs 8-3 and 8-5).

8-15. REPLACEMENT OF ROTARY SWITCHES.

NOTE

In Control, Transponder Set C-6280(P)/APX, Serial No. 1 through 130, manufactured under Contract AF33(657)-14550, rotary switches S201 and S202 were installed with the index key rotated approximately 45° from the horizontal and were marked with a yellow dot on the rear wafer. When one of these switches is to be replaced, the new switch should be installed with the index key in the horizontal position and the 45° offset hole should be plugged.

8-16. To remove and replace either one of the two rotary switches (29 and 32, FO-3; 30 and 37, FO-4; 28 and 31, FO-5), remove the plastic light panel (paragraph 8-3) and the rear panel assembly (paragraph 8-5). Then, proceed as follows:

Step 1. Remove mounting nut and lockwasher (30, 31, or 33, 34, FO-3; 31, 32, or 38, 39, FO-4; 29, 30, or 32, 33, FO-5).

Step 2. On C-6280A(P)/APX, remove two screws (33 and 40, FO-4) and remove nut plate assembly (34 or 41). Remove two nuts (36 or 43) and lift off switch bracket (35 or 42); then, replace nuts (36 or 43) to hold switch together.

Step 3. Gently move switch so terminals are accessible.

Step 4. See wiring diagram FO-2 and solder wires to appropriate terminals of replacement switch.

Step 5. On C-6280A(P)/APX, install switch bracket (35 or 42, FO-4) on switch with nuts (36 or 43).

Step 6. Install replacement rotary switch on subassembly mounting panel with mounting nut and lockwasher.

Step 7. On C-6280A(P)/APX, replace nut plate assembly (34 or 41, FO-4) and screws (33 or 40).

Step 8. Apply a small amount of Lubricant 551D7-44 to switch actuating mechanism, and turn switch several times to distribute lubricant. Remove any excess lubricant.

Step 9. Replace the plastic light panel and rear panel assembly (paragraphs 8-3 and 8-5).

8-17. REPLACEMENT OF THUMBWHEEL SWITCHES.

8-18. To replace any of the six thumbwheel switch assemblies (56 or 57, FO-3; 59 or 60, FO-4; 58 or 59, FO-5), remove plastic light panel (paragraph 8-3) and rear panel assembly (paragraph 8-5), and proceed as follows:

Step 1. Unsolder wires from thumbwheel switch assembly to be removed.

Step 2. Remove screw (53, FO-3; 62, FO-4; 55, FO-5)

that holds switch assembly to angle bracket (49, FO-3; p/o 65, FO-4; 51, FO-5).

Step 3. Remove two flat-head screws (58, FO-3; 61, FO-4; 60, FO-5) that hold switch to subassembly mounting panel (59, FO-3; 65, FO-4; 61, FO-5).

Step 4. Remove thumbwheel switch assembly.

Step 5. To install thumbwheel switch assembly, reverse the procedures in Steps 2 and 3.

Step 6. See wiring diagram FO-2 and solder wires to thumbwheel switch assembly.

Step 7. Replace the plastic light panel and rear panel assembly (paragraphs 8-3 and 8-5).

8-19. REMOVAL AND REPLACEMENT OF PARTS ON THUMBWHEEL SWITCH ASSEMBLIES.

8-20. GENERAL. To remove and replace parts on the thumbwheel switch assemblies, remove switch assembly from transponder set control (paragraph 8-17). Refer to the exploded view in Figure 8-1 and to the appropriate procedure in paragraph 8-21 or 8-22 for parts replacement. When the repair is completed, reinstall the switch assembly.

8-21. REPLACEMENT OF SWITCH WAFER. To replace the switch wafer of the rotary switch (4, Figure 8-1), check that indication knob assembly (9) of all switches, except S212, is set to "7." Set S212 to "3." Then, proceed as follows:

Step 1. Remove two screws (5), spring tension clip (6), and two washers (7) that fasten switch to chassis (15).

Step 2. Lift switch wafer from shaft of shaft and gear assembly (8). If shaft and gear assembly lift up with wafer,

remove wafer from shaft. Check that flats on sides of shaft are vertical, as shown in Figure 8-1, and reinstall shaft in hole in chassis (15), making sure the gear teeth mesh with the teeth of the gear on the chassis assembly.

Step 3. Apply a small amount of Lubricant 551D7-44 to gear teeth, as necessary. Remove any excess lubricant.

Step 4. Position insert of switch wafer as shown in FO-1 and Figure 8-1 (flat side vertical, notch toward front of switch assembly), and install wafer on shaft of shaft and gear assembly.

Step 5. Replace washers (7), spring tension clip (6), and screws (5).

8-22. REPLACEMENT OF INDICATION KNOB ASSEMBLY. Except for S212, to replace the indication knob assembly (9, Figure 8-1), check that the knob is set to "7," as shown in Figure 8-1. For S212, set the knob to "3." Then, proceed as follows:

Step 1. Using C-ring expanding tool, carefully spread retaining ring (10, Figure 8-1). Remove ring, flat washer or washers (11), and spring washer (12).

Step 2. Lift indication knob (9) and spur gear (13), which is attached to knob, from shaft.

Step 3. Install spur gear on replacement indication knob.

Step 4. Apply a small amount of Lubricant 551D744 to gear teeth, as necessary. Remove any excess lubricant.

Step 5. Orient spur gear and indication knob as shown in Figure 8-1 (flat sides in gear vertical), and install knob and gear on shaft.

Step 6. Replace spring washer (12), flat washers (11) as required, and retaining ring (10).

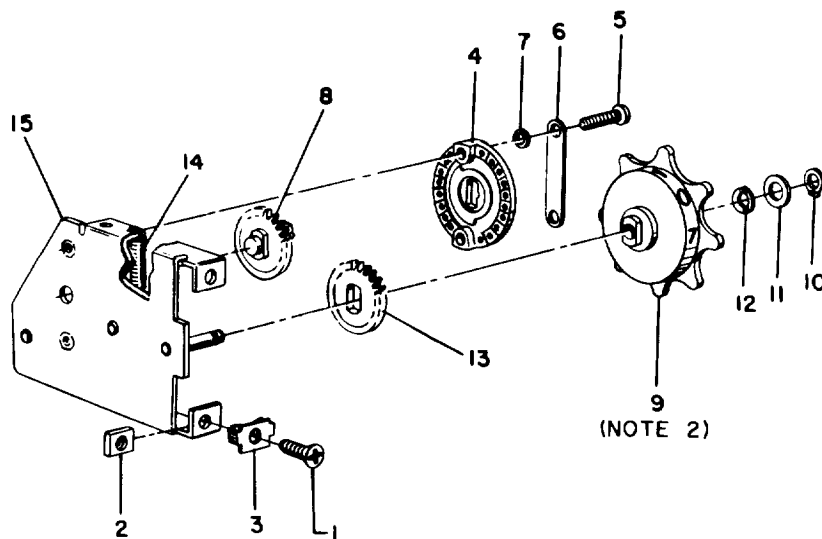

NOTES:

1. Index numbers are assigned according to recommended order of disassembly and correspond to those in the parts list in Section X.
2. Before disassembly of switch, set indication knob assembly (9) as follows: For S211 and S213 through S216, "7" should be adjacent to shaft at front of assembly. For S212, either "3" (not shown) should be adjacent to shaft at front of assembly.

Figure 8-1. Thumbwheel Switch Assembly, Exploded View

T.O. 12P4-2APX-142
NAVAIR 16-35C6280-1
TM 11-5841-268-25

8-23. REPLACEMENT OF INDICATOR LIGHTS.

8-24. To replace either the REPLY or the TEST indicator light (35, FO-3; 44, FO-4; 34, FO-5), unscrew the indicator light from the mounting base and install the replacement light. To replace the mounting base for either of these lights (37, FO-3; 46, FO-4; 36, FO-5), remove plastic light panel (paragraph 8-3) and the rear panel assembly (paragraph 8-5). Unscrew the indicator light and proceed as follows:

Step 1. On C-6280A(P)/APX, loosen mounting nuts (47, FO-4) on both indicator lights, and remove bracket assembly (50).

Step 2. Unsolder wires from mounting base to be replaced.

Step 3. Remove mounting nut (38, FO-3; 47, FO-4; 37, FO-5) and remove mounting base.

Step 4. Install replacement mounting base with mounting nut. On C-6280A(P)/APX, do not tighten mounting nut.

Step 5. See wiring diagram FO-2 and solder wires to mounting base.

Step 6. On C-6280A(P)/APX, replace bracket assembly (50, FO-4) under nuts and washers (48 and 49) and tighten both mounting nuts (47).

Step 7. Screw indicator light into mounting base.

Step 8. Replace the plastic light panel and rear panel assembly (paragraphs 8-3 and 8-5).

8-25. REPLACEMENT OF PANEL LIGHT BASES OF C-6280(P)/APX AND C-6280A(P)/APX.

8-26. To replace any of the five panel light bases of the C-6280(P)/APX or the C-6280A(P)/APX, remove the plastic light panel (paragraph 8-3) and the rear panel assembly (paragraph 8-5), and proceed as follows:

Step 1. Unsolder wires from panel light base (46, FO-3; 56, FO-4) to be replaced.

Step 2. Remove mounting nut and washer (47, 48, FO-3; 57, 58, FO-4), and remove panel light base.

Step 3. Install replacement base with nut and washer.

Step 4. Solder wires to replacement base.

Step 5. Replace the plastic light panel and rear panel assembly (paragraphs 8-3 and 8-5).

8-27. REPLACEMENT OF PANEL LAMPS OF C-6717/APX AND C-7483/APX.

8-28. The 21 panel illuminating lamps of the C-6717/APX and the C-7483/APX are embedded in the plastic light panel (9, FO-5) and are not individually replaceable. If the lamps are defective, refer to paragraph 8-3 and replace the plastic light panel.

8-29. LUBRICATION.

8-30. When new rotary switches have been installed (paragraph 8-15), or when thumbwheel switches have been disassembled (paragraph 8-19), the bearing surfaces of the switch actuating mechanisms and the gear teeth should be lubricated with a small amount of Lubriplate Aerogrease (Lubricant 551D7-44). Remove any excess lubricant. Then, turn switches several times to distribute lubricant.

8-31. EQUIPMENT PERFORMANCE CHECK AFTER COMPLETION OF REPAIRS.

8-32. When the transponder set control has been repaired and reassembled, the operation of the controls and indicators should be checked to verify satisfactory operation. Perform the check-out procedures of paragraphs 7-20 through 7-26. When these checks have been successfully performed, the transponder set control is ready to be returned to service and will furnish satisfactory operation equivalent to that of new equipment.

8-33. (Army) DEPOT OVERHAUL STANDARDS.

8-34. INTRODUCTION. After rebuild or repair, Control, Transponder Set C-6280A(P)/APX must be tested thoroughly to insure that it meets adequate performance standards for return to stock and reissue. Use the tests of paragraphs 7-20 through 7-26 to measure the performance of the repaired transponder set control. It is mandatory that repaired equipment to be reissued, or returned to stock for reissue, meet all of the performance standards given in paragraphs 8-35 through 8-40.

8-35. REPAIR STANDARDS. Applicable procedures of the Signal Corps depot performing this test and its general standards for repaired signal equipment form a part of the requirements for testing this transponder set control.

8-36. TECHNICAL PUBLICATIONS. No technical publications are required other than this manual.

8-37. MODIFICATION WORK ORDERS. Perform all modification work orders applicable to this equipment before making the tests specified. DA Pam 310-7 lists all available MWOs.

8-38. TEST FACILITIES REQUIRED. The only item required for depot testing the transponder set control is Multi-meter ME-26/U, or equivalent.

8-39. GENERAL TEST REQUIREMENTS. A source of 28 volts DC is required for testing the indicator lights of a repaired transponder set control. Also, depending on the lamps installed, a source of either 6 volts DC or 28 volts DC is required for testing the panel illuminating lights. The test wiring described in paragraph 3-5 of this manual may be used to facilitate measurements between contact pins of the electrical connector.

8-40. TESTS. After repairing or rebuilding the transponder set control, perform the check-out procedures of paragraphs 7-20 through 7-26.

8-41. PACKAGING FOR STORAGE OR SHIPMENT.

8-42. A packaging diagram for limited storage or shipment of the transponder set control is shown in Figure 8-2. When

designated materials are not available, equivalent materials may be substituted.

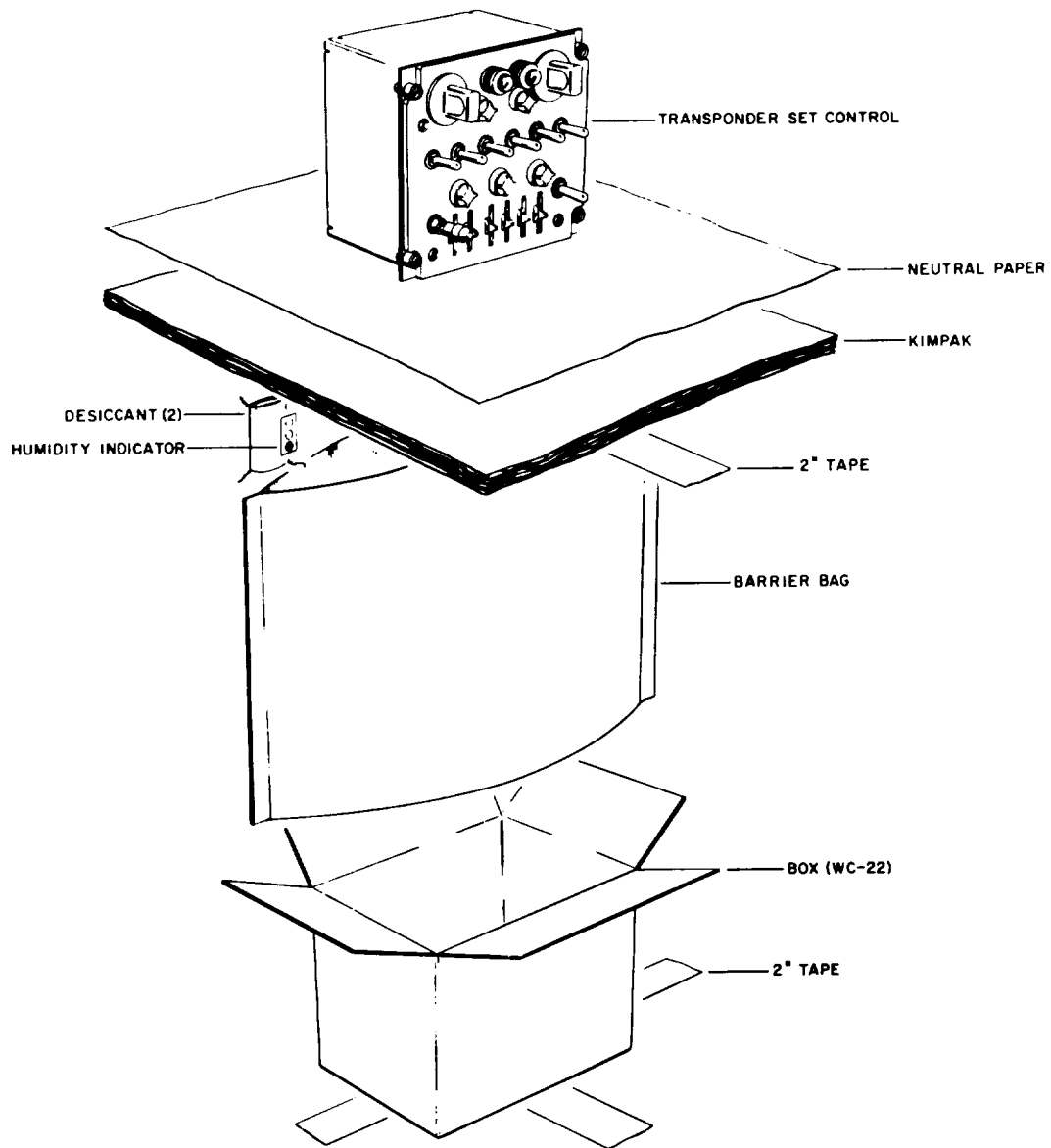

Figure 8-2. Control, Transponder Sat C-6280(P)/APX, C-6280A(P)/APX, C-6717/APX, and C-7483/APX, Packaging Diagram

SECTION IX

(Army) DEMOLITION OF MATERIEL TO PREVENT ENEMY USE

9-1. AUTHORITY FOR DEMOLITION.

9-2. Demolition of the equipment will be accomplished only upon order of the commander. Use the destruction procedures outlined in paragraph 9-4 to prevent further use of the equipment.

9-3. METHODS OF DESTRUCTION.

9-4. The tactical situation and time available will determine the method to be used when destruction of equipment is ordered. In most cases, it is preferable to demolish completely some portions of the equipment rather than partially destroy all of the equipment components.

a. Smash. Smash the front panel, case, cover, switches, and controls; open the case and smash all terminals, switches, and connectors; use sledges, axes, hammers, crowbars, and any other heavy tool available.

b. Cut. Use axes, machetes, or other similar tools to cut wiring and interconnecting cabling.

WARNING

BE EXTREMELY CAREFUL WITH EXPLOSIVES AND INCENDIARY DEVICES. USE THESE ITEMS ONLY WHEN THE NEED IS URGENT.

c. Burn. Burn the technical manual frost. Burn as much of the equipment as possible; use gasoline, oil, flame throwers, and similar items. Use incendiary grenades to complete the destruction of unit interiors.

d. Explode. If explosives are necessary, use firearms, grenades, or TNT.

e. Dispose. Bury or scatter the destroyed parts in slit trenches or foxholes, or throw them into nearby streams.

9-5. REPORT OF DESTRUCTION.

9-6. The reporting of the destruction of the equipment will be made through command channels.

SECTION X

(Air Force, Navy) ILLUSTRATED PARTS BREAKDOWN

NOTE

(Army) Refer to TM 11-5841-268-25P for parts identification.

10-1. SCOPE AND APPLICABILITY.

10-2. This section contains an illustrated parts breakdown of the replaceable parts of Control, Transponder Set C-6280 (P)/APX, C-6280A(P)/APX, C45717/APX, and C-7483/APX, manufactured under the contracts listed in paragraph 1-2. The parts breakdown consists of Group Assembly Parts Lists (Tables 10-1 through 10-4) and related exploded views (Figures 10-1, FO-3, FO-4, FO-5), a Numerical Index (Table 10-5), and a Reference Designation Index (Table 10-6). A List of Manufacturers (paragraph 10-17) of the parts used in the transponder set controls is also included.

10-3. GROUP ASSEMBLY PARTS LISTS.

104. A separate Group Assembly Parts List and exploded view is used for the C-6280(P)/APX, for the C-6280A(P)/APX, and for the C-6717/APX and C-7483/APX. In each of these lists, the parts are listed in a recommended order of disassembly, except for attaching parts which are listed directly after the part attached. Index numbers are assigned

in sequence to each part and are keyed to the related exploded view. Part numbers assigned by the contractors, manufacturers, or Government are included for identification (refer to paragraph 10-7). Part descriptions are indented to show their relationship to the previously listed assembly or subassembly. Attaching parts are identified and are listed in the same indented column as the part attached; the symbol "...*..." indicates the completion of the attaching parts. The code letters inserted in the Usable On Code column are defined in paragraph 10-10.

10-5. NUMERICAL INDEX AND REFERENCE DESIGNATION INDEX.

10-6. Both the Numerical Index and the Reference Designation Index are combined lists applicable to all the transponder set controls. The Numerical Index has five columns of numerical data with each line representing a single part. The Reference Designation Index is a three-column table which lists only those electrical functioning parts of the transponder set controls to which reference designations have been assigned. In both indexes, one column cross-references the figure and index number of the part, as listed in the parts lists and shown on the related exploded view.

T.O. 12P4-2APX-142
NAVAIR 16-35C6280-1
TM 11-5641-268-25

10-7. PART NUMBERS.

10-8. Two part number columns, one for each contractor, are used in the Group Assembly Parts Lists. The part number listed may be the contractor's number or the Government standard part number. Where a dash (-) is shown in one part number column (to indicate a deliberate omission) and a part number is shown in the other part number column, it indicates that the part is limited in use to the contractor for whom the part number is shown. Other part numbers, such as the manufacturer's part number for the part used by the contractor, are included within parentheses in the Description column at the end of the part description.

10-9. The numerical code inserted at the top of each Part Number column identifies the contractor (refer to paragraph 10-17). The numerical code for the manufacturer of the part, if other than the contractor, is included within parentheses, together with the manufacturer's part number, in the Description column at the end of the part description. It should be noted that the absence of a numerical code and part number following a part description indicates that the item is either a contractor's part or a Government standard part.

10-10. USABLE ON CODES.

10-11. **APPLICABILITY.** In the Group Assembly Parts Lists, a letter designation inserted in the Usable On Code column indicates a limitation of use of the part. The absence of a code in the Usable On Code column indicates that the part so listed is usable as a replacement in all transponder set controls, if used for the same function. The applicability of these codes is defined in paragraphs 10-12 and 10-13.

10-12. **CODES A AND B.** Control, Transponder Set C-6280(P)/APX and Control, Transponder Set C-6280A(P)/APX can be used in aircraft having either a 6-volt or 28-volt panel-illuminating lamp supply, provided the lamps installed have the same voltage rating as the aircraft's lamp supply. To distinguish between these lamps, the Usable On Code "A" has been assigned to the 6-volt lamps and the Usable On Code "B" has been assigned to the 28-volt lamps.

10-13. **CODES C, D, AND E.** Usable On Codes "C," "D," and "E" are used to designate differences between the falterers of the panel light holders. Code "C" is used for the blue-white filter, code "D" is used for the red filter, and code "E" is used for the clear falterer.

10-14. SOURCE CODES.

10-15. (*Navy*) Definitions and an explanation of Source, Recoverability /Accountability, and Kit Codes used in the Numerical Index of this manual are contained in BUWEPS INSTRUCTIONS 4423.2.

10-16. (*Air Force*) Source Codes in the Source Code column of the Numerical Index indicate the procurability and

maintainability status of the parts used in the transponder set controls. Policies, general information, and procedures for changing source and maintenance coding are contained in T.O. 00-25-195. Generally, the source codes and maintenance repair level codes herein (see Source Code and Repair Code columns) were assigned by Air Force personnel when this equipment was purchased. Assignment of codes was influenced by (a) maintenance policies, (b) predicted maintenance actions, (c) base facilities and capabilities, and (d) economic considerations. Definitions of these codes follow:

- P** Code "P" is applied to parts on which usage is anticipated or known. Code "P" parts may be requisitioned and installed by any maintenance level unless followed by the letter "D" (depot), which restricts requisition and replacement to depot level only. Restricted service manufacture is considered practicable, but only after an attempt has been made to procure from supply sources.
- P1** Code "P1" is applied to parts which are very difficult, impractical, or uneconomical to manufacture. Code "P1" parts may be requisitioned and installed by any maintenance level unless followed by the letter "D" (depot), which restricts requisition and replacement to depot level only.
- P1D** Code "P1D" identifies parts which may be requisitioned and installed by Air Force activities which are authorized depot-level maintenance only. This code is applied to parts which are impractical for service manufacture.
- P2** Code "P2" identifies insurance-type spare parts which can be installed by any Air Force activity consistent with the Command's authorized scope of maintenance. This code is applied to such parts which are basically structural and for which no usage is anticipated or known; require special tools, templates, and/or jigs and are very difficult, impractical, or uneconomical to manufacture by Air Force activities. These items are not subject to periodic replacement or wearout but may require infrequent replacement as a result of accidents or other unexpected occurrences.
- P2D** Code "P2D" identifies insurance-type spare parts which may be installed by Air Force activities which are authorized depot-level maintenance only. This code is applied to parts as described under Code "P2."

- M** Code "M" is applied to parts which are within the capabilities of any activity to manufacture. Procurement is not justified in view of relatively low usage, or storage and installation factors of these parts. Needs are to be met by local manufacture only as required.
- M1** Code "M1" is applied to parts which can be manufactured only by utilizing the capabilities of the depot. Procurement and stocking of these parts is not justified in view of their relatively low usage and installation factors. The needs of all activities are to be met through manufacture or requisition from the nearest appropriate depot.
- A** Code "A" is applied to assemblies made up of two or more parts, at least one of which is purchased and carries an individual part number or description, which may be assembled by any maintenance level.
- A1** Code "A1" applies to assemblies made up of two or more parts, at least one of which is purchased and carries an individual part number and description, which may be assembled only by activities having depot facilities.
- X** Code "X" is applied to main structural members of similar parts which, if required, would suggest extensive repair. The need of a part or parts so coded "X" (wing spars, center section structure, etc.) should normally result in a recommendation to retire the article from service.
- X1** Code "X1" is applied to parts for which procurement of the next larger assembly so coded "P1" is justified; e.g. an integral detail part such as a welded segment inseparable from its assembly, a part machined in a matched set, or a part of an assembly which, if required, would suggest extensive reconditioning of each assembly.
- X1D** Code "X1D" identifies parts described under the "X1" code but which are applicable to AF activities authorized depot-level maintenance only.
- X2** Code "X2" is applied to parts which are not procured for stock, but may be acquired for use through salvage and reclamation. Activities requiring such parts shall attempt to obtain from salvage; if not obtainable from salvage, such parts shall be requisitioned through normal supply channels with supporting justification. Repeated request shall justify change in code to "P1" if considered economical to procure and stock such parts.
- X2D** Code "X2D" identifies parts described under the "X2" code but which are applicable to AF activities authorized depot-level maintenance only. Repeated requests for such parts shall justify a change to a "P1D" or "P2D" code, as applicable, if considered economical and feasible to procure and stock such parts.
- C** Code "C" -Cure Dated Parts Kit. Code "C" is applied to kits containing parts that have a specific period of time (cure-date) to remain in storage without affecting their serviceability and are subject to deterioration due to aging or exposure. The cure-date for the kit is established on the shortest life item within the kit. C-Kit contains parts required for maintenance and overhaul and will be used in conjunction with Overhaul (Code "D") Repair Kits and/or Minor or Field (Code "F") Repair Kits, as applicable.
- D** Major Overhaul Kit Code "D" is applied to kits which are available only to maintenance authorized to perform depot or major overhaul. These kits do not contain cure-dated parts.
- F** Minor or Field Repair Kit Code "F" is applied to kits which are available to maintenance activities authorized to perform minor or field repair, including overhaul activities in support of field activities. These kits do not contain cure-dated parts.
- u** Code "U" -Parts Not Procured, Manufactured, or Stocked. Code "U" is applied to installation drawings, diagrams, instruction sheets, field service drawing numbers, and parts not otherwise of supply significance, including obsolete parts, which cannot be procured or service manufactured.
- KB** Code "KB"-Component of both "F" Kit and "D" Kit. Code "KB" is applied to items which are components of both an F-Kit and a D-Kit. Also stocked separately in the appropriate class if followed by the letter "P."

T.O. 12P4-2APX-142
NAVAIR 16-35C6280-1
TM 11-5641-268-25

KC	Code "KC"-Component of C-Kit. Code "KC" is applied to items which are components of a C-Kit.	<i>Code</i>	<i>Name and Address</i>
		72619	Dialight Corporation 60 Stewart Avenue Brooklyn, New York 11237
		72794	Dzus Fastener Company, inc. 425 Union Boulevard West Islip, New York 11795
		72914	Grimes Manufacturing Company 515 North Russell Urbana, Ohio 43078
		72962	Elastic Stop Nut Corp. of America 2330 Vauxhall Road Union, New Jersey 07083

10-17. LIST OF MANUFACTURERS.

10-18. The numerical codes and the identifying names and addresses of the contractors and of the manufacturers of parts not earned under a contractor's number follow. The list is arranged code-to-name, in numerical sequence, based on the codes contained in Cataloging Handbook H4-1 and H4-2, Federal Supply Code for Manufacturers.

<i>Code</i>	<i>Name and Address</i>	<i>Code</i>	<i>Name and Address</i>
00781	Aircraft Radio Corporation Rockaway Valley Road Boonton, New Jersey 07005	79963	Zierick Manufacturing Corporation 83 Rockdale Avenue New Rochelle, New York 10802
61007	Tubular Rivet & Stud Division Townsend Company 530 West Street Braintree, Massachusetts 02185	86577	Precision Metal Products of Maiden, Inc. 41 Elm Street Stoneham, Massachusetts 02180
70117	Admiral Corporation 3800 W. Cortland Street Chicago, Illinois 60647	94375	Automatic Metal Products Corp. 315-323 Berry Street Brooklyn, New York 11211

TABLE 10-1. C-6280(P)/APX GROUP ASSEMBLY PARTS LIST

FIGURE & INDEX NUMBER	PART NUMBER (70117)	PART NUMBER (00781)	DESCRIPTION							UNITS PER ASSY	USABLE ON CODE
			1	2	3	4	5	6	7		
FO-3-	GD4451	36500	CONTROL, TRANSPONDER SET, C-6280(P)/APX.							1	
-1	GD4457	36508	COVER ASSEMBLY, Dust							1	
-2	513D8-43-103	36520-0043	STUD, Turnlock fastener (72794 Part No. A3-20)							2	
-3	513D8-7	36520-0007	EYELET, Turnlock fastener (72794 Part No. GH-3)							2	
-4	515D3225	36525	COVER, Dust							1	
-5	533C326-1	36546-0001	DIAL, Control.							1	
-6	MS51021-32	MS51021-32	(ATTACHING PARTS) SETSCREW							2	
-7	533C326-2	36546-0002	DIAL, Control.							1	
-8	MS51021-32	MS51021-32	(ATTACHING PARTS) SETSCREW							2	
-9	582A11-12	36576	HOLDER, Illuminated, panel light, blue-white. (72914 Part No. A7077-5)							5	C
-9	(M625010)-11A	(MS25010)-11A	HOLDER, Illuminated, panel light, red.							5	D
-9	(MS25010)-12A	(MS25010)-12A	HOLDER, Illuminated, panel light, clear.							5	E
-10	MS25237-327	MS25237-327	LAMP, Incandescent, 28-volt							5	A
-10	MS25237-328	MS25237-328	LAMP, Incandescent, 6-volt.							5	B
-11	521D63	36531	PANEL, Light							1	
-12	MS35233-28	MS35233-28	(ATTACHING PARTS) SCREW, Machine							4	
-	GD4462	36511	TRANSPONDER SET CONTROL SUBASSEMBLY							1	
-13	526C457	36533	PLATE, Identification (ATTACHING PARTS)							1	
-14	MS51957-1	MS51957-1	SCREW, Machine							4	
-15	526C454	36534-0001	PLATE, Identification (ATTACHING PARTS)							1	
-16	MS51957-1	MS51957-1	SCREW, Machine							4	
-17	GD4455	36506	PANEL ASSEMBLY, Back (ATTACHING PARTS)							1	
-18	MS51957-25	MS51957-28	SCREW, Machine							4	
-19	MS35338-136	MS35338-136	WASHER, Lock							4	
-20	513D8-4-103	36520-0004	LOCKSPRING, Turnlock (72794 Part No. S3-150)							2	
-21	506C16-12	36518-0012	RIVET, Tubular (61007 Part No. 20159-1/8 in.)							4	
-22	515D3226	36526	PANEL							1	
-	GD4492	36512	CABLE ASSEMBLY, Special purpose							1	
-23	MS24264R22B 55PX	MS24264R22B 55PX	CONNECTOR, Receptacle, electrical							1	
-24	MS51957-15	MS51957-15	(ATTACHING PARTS) SCREW, Machine							4	
-25	MS35649-244	MS35649-244	NUT, Hexagon.							4	
-26	MS35338-135	MS35338-135	WASHER, Lock							4	
-27	527C810	36540	POST, Electrical-mechanical equipment. (ATTACHING PARTS)							4	
-28	MS24693C26	MS24693C26	SCREW, Machine							4	
-29	576C169	-	SWITCH, Rotary (76854 Part No. 250994AF1)							1	
-29	-	36554	SWITCH, Rotary (76854 Part No. 261360AF1) (ATTACHING PARTS)							1	
-30	-	-	NUT, Hexagon (supplied w/ -29)							1	
-31	-	-	WASHER, Lock (supplied w/ -29).							1	
-32	576D176	-	SWITCH, Rotary (76854 Part No. 260020AF3).							1	
-32	-	36555	SWITCH, Rotary (76854 Part No. 261361AF3). (ATTACHING PARTS)							1	
-33	-	-	NUT, Hexagon (supplied w/ -32).							1	
-34	-	-	WASHER, Lock (supplied w/ -32).							1	
-35	MS25041-3	MS25041-3	LIGHT, Indicator							2	
-36	MS25237-327	MS25237-327	LAMP, Incandescent, 28-volt							2	
-37	-	-	BASE, Mounting (p/o -35) (ATTACHING PARTS)							2	
-38	MS25082-B8	MS25082-B8	NUT, Hexagon (supplied w/ -35)							2	
-39	AN936A716S	AN936A716S	WASHER, Lock (supplied w/ -35).							2	
-40	MS25082-B8	MS25082-B8	NUT, Hexagon (supplied w/ -35).							2	

T.O. 12P4-2APX-142
 NAVAIR 16-35C6280-1
 TM 11-5841-268-25

TABLE 10-1. C-6280(P)/APX GROUP ASSEMBLY PARTS LIST-Continued

FIGURE & INDEX NUMBER	PART NUMBER (70117)	PART NUMBER (00781)	DESCRIPTION							UNITS PER ASSY	USABLE ON CODE
			1	2	3	4	5	6	7		
FO-3-41	MS25125-C3	MS25125-C3	.	.	SWITCH, Toggle.	1	
-	MS25082-B8	MS25082-B8	.	.	(ATTACHING PARTS)		
-	AN936A716S	AN936A716S	.	.	NUT, Hexagon (supplied w/ -41)	1	
-	MS25081-1	MS25081-1	.	.	WASHER, Lock (supplied w/ -41)	1	
-	MS25082-B8	MS25082-B8	.	.	WASHER, Key (supplied w/ -41)	1	
-42	MS35059-21	MS35059-21	.	.	NUT, Hexagon (supplied w/ -41)	1	
-	MS25082-B8	MS25082-B8	.	.	SWITCH, Toggle.	1	
-	AN936A716S	AN936A716S	.	.	(ATTACHING PARTS)		
-	MS25081-1	MS25081-1	.	.	NUT, Hexagon (supplied w/ -42)	1	
-	MS25082-B8	MS25082-B8	.	.	WASHER, Lock (supplied w/ -42)	1	
-43	MS25201-5	MS25201-5	.	.	WASHER, Key (supplied w/ -42)	1	
-	MS25082-B8	MS25082-B8	.	.	NUT, Hexagon (supplied w/ -42)	1	
-	AN936A716S	AN936A716S	.	.	SWITCH, Toggle.	4	
-	MS25081-1	MS25081-1	.	.	(ATTACHING PARTS)		
-	MS25082-B8	MS25082-B8	.	.	NUT, Hexagon (supplied w/ -43)	4	
-	AN936A716S	AN936A716S	.	.	WASHER, Lock (supplied w/ -43)	4	
-	MS25081-1	MS25081-1	.	.	WASHER, Key (supplied w/ -43)	4	
-	MS25082-B8	MS25082-B8	.	.	NUT, Hexagon (supplied w/ -43)	4	
-44	MS35059-31	MS35059-31	.	.	SWITCH, Toggle.	1	
-	MS25082-B8	MS25082-B8	.	.	(ATTACHING PARTS)		
-	AN936A716S	AN936A716S	.	.	NUT, Hexagon (supplied w/ -44)	1	
-	MS25081-1	MS25081-1	.	.	WASHER, Lock (supplied w/ -44)	1	
-	MS25082-B8	MS25082-B8	.	.	WASHER, Key (supplied w/ -44)	1	
-	MS35058-31	MS35058-31	.	.	NUT, Hexagon (supplied w/ -44)	1	
-45	MS35058-31	MS35058-31	.	.	SWITCH, Toggle.	1	
-	MS25082-B8	MS25082-B8	.	.	(ATTACHING PARTS)		
-	AN936A716S	AN936A716S	.	.	NUT, Hexagon (supplied w/ -45)	1	
-	MS25081-1	MS25081-1	.	.	WASHER, Lock (supplied w/ -45)	1	
-	MS25082-B8	MS25082-B8	.	.	WASHER, Key (supplied w/ -45)	1	
-46	MS25010A	MS25010A	.	.	NUT, Hexagon (supplied w/ -45)	1	
-	MS25082-B8	MS25082-B8	.	.	BASE, Mounting	5	
-47	MS25082-B8	MS25082-B8	.	.	(ATTACHING PARTS)		
-48	AN936A716S	AN936A716S	.	.	NUT, Hexagon (supplied w/ -46)	5	
-49	515B3222	36522	.	.	WASHER, Lock (supplied w/ -46)	5	
-50	AN507C440R4	AN507C440R4	.	.	BRACKET, Angle.	1	
-51	MS35649-44	MS35649-44	.	.	(ATTACHING PARTS)		
-52	MS35338-79	MS35338-79	.	.	SCREW, Machine	2	
-53	MS51957-11	MS51957-12	.	.	NUT, Hexagon	2	
-54	509C4-5	8927-0004	.	.	WASHER, Lock	2	
-55	MS35338-78	MS35338-78	.	.	SCREW, Machine	6	
-56	GD4460-1	36510-0001	.	.	TERMINAL, Lug	2	
-57	GD4460-2	36510-0002	.	.	WASHER, Lock	4	
-58	AN507C440R4	AN507C440R4	.	.	SWITCH ASSEMBLY (See Figure 10-1)	5	
-59	GD4456	36507	.	.	SWITCH ASSEMBLY (See Figure 10-1)	1	
-60	501A40-5	36571-0005	.	.	(ATTACHING PARTS)		
-61	501A40-6	36571-0006	.	.	SCREW, Machine (supplied w/ -56 and -57)	12	
-62	501A40-7	36571-0007	.	.	PANEL MOUNTING SUBASSEMBLY	1	
-63	501A40-8	36571-0008	.	.	STUD ASSEMBLY, Turnlock	4	
-64	502D18-91	36572-0462	.	.	STUD, Turnlock (72794 Part No. PF3 1-2 38)	1	
-65	515D3224	36524	.	.	SPRING, Compression (72794 Part No. PS3 1-2)	1	
			.	.	EYELET, Turnlock (72794 Part No. PC3 1-2)	1	
			.	.	NUT, Plain cinch (72962 Part No. 79NCFMA2-62)	4	
			.	.	PANEL	1	

TABLE 10-2. C-6280A(P)/APX GROUP ASSEMBLY PARTS LIST

FIGURE & INDEX NUMBER	PART NUMBER (70117)	PART NUMBER (00781)	DESCRIPTION							UNITS PER ASSY	USABLE ON CODE
			1	2	3	4	5	6	7		
FO-4-	GD4937	38270	CONTROL, TRANSPONDER SET, C-6280A(P)/APX							1	
-1	GD4447	36589	COVER ASSEMBLY, Dust							1	
-2	513D8-43-103	36520-0043	STUD, Turnlock fastener (72794 Part No. A3-20)							2	
-3	513D8-7	36520-0007	EYELET, Turnlock fastener (72794 Part No. GH-3)							2	
-4	515D3225	36592	COVER, Dust							1	
-5	533C326-1	36546-0001	DIAL, Control							1	
-6	MS51021-32	MS51021-32	(ATTACHING PARTS)								
-7	533C326-2	36546-0002	SETSCREW							2	
-8	MS51021-32	MS51021-32	(ATTACHING PARTS)								
-9	582A11-12	36576	DIAL, Control							1	
-9	(MS25010)-11A	(MS25010)-11A	(ATTACHING PARTS)								
-9	(MS25010)-12A	(MS25010)-12A	SETSCREW							2	
-10	MS25237-327	MS25237-327	HOLDER, Illuminated, panel light, blue-white							5	C
-10	MS25237-328	MS25237-328	(72914 Part No. A7077-5)								
-11	521D53	38272	HOLDER, Illuminated, panel light, red							5	D
-12	MS35233-28	MS35233-28	HOLDER, Illuminated, panel light, clear							5	E
-13	-	4041	LAMP, Incandescent, 28-volt							5	A
-14	-	AN93586	LAMP, Incandescent, 6-volt							5	B
-	GD4462	38273	PANEL, Light							1	
-15	526B516	36533	(ATTACHING PARTS)								
-16	MS51957-1	MS51957-1	SCREW, Machine							4	
-17	526C454	36534-0001	NUT, Hexagon, brs, ni pl, 6-32 thd x 0.078 in. thk.							4	
-18	MS51957-1	MS51957-1	WASHER, Lock							4	
-19	GD4455	38277	TRANSPONDER SET CONTROL SUBASSEMBLY							1	
-20	MS51957-27	MS51957-27	PLATE, Identification							1	
-21	MS35338-79	MS35338-79	(ATTACHING PARTS)								
-22	513D8-4-103	36520-0004	SCREW, Machine							4	
-23	506C16-12	36518-0012	PLATE, Identification							1	
-24	515D3226	38278	(ATTACHING PARTS)								
-	GD4492	36512	SCREW, Machine							4	
-25	MS24264R22 B55P	MS24264R22 B55P	PANEL ASSEMBLY, Back							1	
-26	MS51957-15	MS51957-15	(ATTACHING PARTS)								
-27	MS51957-15	MS51957-15	SCREW, Machine							2	
-28	MS35649-44	MS35649-44	SCREW, Machine							2	
-29	MS35338-78	MS35338-78	NUT, Hexagon							2	
-30	576C169	-	WASHER, Lock							2	
-30	-	36554	SWITCH, Rotary (76854 Part No. 250994AF1)							1	
-31	-	-	SWITCH, Rotary (76854 Part No. 261360AF1)							1	
-32	-	-	(ATTACHING PARTS)								
-33	-	AN507C440R5	NUT, Hexagon (supplied w/ -30)							1	
-34	-	36584	WASHER, Lock (supplied w/ -30)							1	
-35	-	36586	SCREW, Machine							2	
-36	-	-	NUT PLATE ASSEMBLY							1	
-37	576D176	-	BRACKET, Switch							1	
-37	-	36555	(ATTACHING PARTS)								
-38	-	-	NUT, Hexagon (supplied w/ -37)							1	
-39	-	-	WASHER, Lock (supplied w/ -37)							1	
-40	-	AN507C440R5	SCREW, Machine							2	
-41	-	36584	NUT PLATE ASSEMBLY							1	
-42	-	36586	BRACKET, Switch							1	
-43	-	-	(ATTACHING PARTS)								
			NUT, Hexagon (supplied w/ -37)							2	

T.O. 12P4-2APX-142
 NAVAIR 16-35C6280-1
 TM 11-5841-268-25

TABLE 10-2. C-6280A(P)/APX GROUP ASSEMBLY PARTS LIST-Continued

FIGURE & INDEX NUMBER	PART NUMBER (70117)	PART NUMBER (00781)	DESCRIPTION							UNITS PER ASSY	USABLE ON CODE	
			1	2	3	4	5	6	7			
FO-4-44	MS25041-3	MS25041-3	.	.	LIGHT, Indicator						2	
-45	MS25237-327	MS25237-327	.	.	LAMP, Incandescent, 28-volt						2	
-46	-	-	.	.	BASE, Mounting (p/o -44)						2	
					(ATTACHING PARTS)							
-47	MS25082-B8	MS25082-B8	.	.	NUT, Hexagon (supplied w/ -44)						2	
-48	AN936A716S	AN936A716S	.	.	WASHER, Lock (supplied w/ -44)						2	
-49	MS25082-B8	MS25082-B8	.	.	NUT, Hexagon (supplied w/ -44)						2	
-50	-	36587	.	.	BRACKET ASSEMBLY						1	
-51	MS25125-C3	MS25125-C3	.	.	SWITCH, Toggle						1	
					(ATTACHING PARTS)							
-	MS25082-B8	MS25082-B8	.	.	NUT, Hexagon (supplied w/ -51)						1	
-	AN936A716S	AN936A716S	.	.	WASHER, Lock (supplied w/ -51)						1	
-	MS25081-1	MS25081-1	.	.	WASHER, Key (supplied w/ -51)						1	
-	MS25082-B8	MS25082-B8	.	.	NUT, Hexagon (supplied w/ -51)						1	
-52	MS35059-21	MS35059-21	.	.	SWITCH, Toggle						1	
					(ATTACHING PARTS)							
-	MS25082-B8	MS25082-B8	.	.	NUT, Hexagon (supplied w/ -52)						1	
-	AN936A716S	AN936A716S	.	.	WASHER, Lock (supplied w/ -52)						1	
-	MS25081-1	MS25081-1	.	.	WASHER, Key (supplied w/ -52)						1	
-	MS25082-B8	MS25082-B8	.	.	NUT, Hexagon (supplied w/ -52)						1	
-53	MS25201-5	MS25201-5	.	.	SWITCH, Toggle						4	
					(ATTACHING PARTS)							
-	MS25082-B8	MS25082-B8	.	.	NUT, Hexagon (supplied w/ -53)						4	
-	AN936A716S	AN936A716S	.	.	WASHER, Lock (supplied w/ -53)						4	
-	MS25081-1	MS25081-1	.	.	WASHER, Key (supplied w/ -53)						4	
-	MS25082-B8	MS25082-B8	.	.	NUT, Hexagon (supplied w/ -53)						4	
-54	MS35059-31	MS35059-31	.	.	SWITCH, Toggle						1	
					(ATTACHING PARTS)							
-	MS25082-B8	MS25082-B8	.	.	NUT, Hexagon (supplied w/ -54)						1	
-	AN936A716S	AN936A716S	.	.	WASHER, Lock (supplied w/ -54)						1	
-	MS25081-1	MS25081-1	.	.	WASHER, Key (supplied w/ -54)						1	
-	MS25082-B8	MS25082-B8	.	.	NUT, Hexagon (supplied w/ -54)						1	
-55	MS35058-31	MS35058-31	.	.	SWITCH, Toggle						1	
					(ATTACHING PARTS)							
-	MS25082-B8	MS25082-B8	.	.	NUT, Hexagon (supplied w/ -55)						1	
-	AN936A716S	AN936A716S	.	.	WASHER, Lock (supplied w/ -55)						1	
-	MS25081-1	MS25081-1	.	.	WASHER, Key (supplied w/ -55)						1	
-	MS25082-B8	MS25082-B8	.	.	NUT, Hexagon (supplied w/ -55)						1	
-56	MS25010A	MS25010A	.	.	BASE, Mounting						5	
					(ATTACHING PARTS)							
-57	MS25082-B8	MS25082-B8	.	.	NUT, Hexagon (supplied w/ -56)						5	
-58	AN936A716S	AN936A716S	.	.	WASHER, Lock (supplied w/ -56)						5	
-59	GD4460-1	36510-0001	.	.	SWITCH ASSEMBLY (See Figure 10-1)						5	
-60	GD4460-2	36510-0002	.	.	SWITCH ASSEMBLY (See Figure 10-1)						1	
					(ATTACHING PARTS)							
-61	AN507C440R4	AN507C440R4	.	.	SCREW, Machine (supplied w/ -59 and -60)						12	
-62	MS51957-13	MS51957-13	.	.	SCREW, Machine						6	
-63	509C4-5	8927-0004	.	.	TERMINAL, Lug						2	
-64	MS35338-78	MS35338-78	.	.	WASHER, Lock						4	
-65	GD4456	38274	.	.	PANEL ASSEMBLY						1	
-66	501A40-5	36571-0005	.	.	STUD ASSEMBLY, Turnlock						6	
-67	501A40-6	36571-0006	.	.	STUD, Turnlock (72794 Part No. PF3 1-2 38)						1	
-68	501A40-7	36571-0007	.	.	SPRING, Compression (72794 Part No. PS3 1-2)						1	
-69	501A40-8	36571-0008	.	.	EYELET, Turnlock (72794 Part No. PC3 1-2)						1	
-70	502D18-91	-	.	.	NUT, Plain cinch (72962 Part No. 79NCFMA2-62)						4	
-70	-	8948 0262	.	.	NUT, Self-locking, round						4	
					(72962 Part No. 12NCFMA2-62)							
-71	515D3224	38275	.	.	PANEL						1	

TABLE 10-3. C-6717/APX AND C-7483/APX GROUP ASSEMBLY PARTS LIST

FIGURE & INDEX NUMBER	PART NUMBER (70117)	PART NUMBER (00781)	DESCRIPTION							UNITS PER ASSY	USABLE ON CODE
			1	2	3	4	5	6	7		
FO-5-	GD4548	39050-6000	CONTROL, TRANSPONDER SET, C-6717/APX							1	
FO-5-	-	39050-7000	CONTROL, TRANSPONDER SET, C-7483/APX							1	
-1	GD4549	36508	COVER ASSEMBLY, Dust (C-6717/APX)							1	
-1	-	36508	COVER ASSEMBLY, Dust (C-7483/APX)							1	
-2	513D8-43-103	36520-0043	STUD, Turnlock fastener (72794 Part No. A3-20)							2	
-3	513D8-7	36520-0007	EYELET, Turnlock fastener (72794 Part No. GH-3)							1	
-4	515D3225	36525	COVER, Dust							1	
-5	533C326-1	36546-6001	DIAL, Control							1	
-6	MS51021-32	MS51021-32	(ATTACHING PARTS) SETSCREW							2	
-7	533C326-2	36546-6002	DIAL, Control							1	
-8	MS51021-32	MS51021-32	(ATTACHING PARTS) SETSCREW							2	
-9	521D55	39054-6000	PANEL, Light (C-6717/APX)							1	
-9	-	39054-7000	PANEL, Light (C-7483/APX)							1	
-10	MS35233-28	MS35233-28	(ATTACHING PARTS) SCREW, Machine							4	
-	GD4550	39059-6000	TRANSPONDER SET CONTROL SUBASSEMBLY.							1	
-	-	39059-7000	(C-6717/APX) TRANSPONDER SET CONTROL SUBASSEMBLY.							1	
-11	526C478	39055-0002	(C-7483/APX) PLATE, Identification (C-6717/APX)							1	
-11	-	39056	PLATE, Identification (C-7483/APX)							1	
-12	MS51957-1	MS51957-1	(ATTACHING PARTS) SCREW, Machine							4	
-13	526C454	36534-0001	PLATE, Identification							1	
-14	MS51957-1	MS51957-1	(ATTACHING PARTS) SCREW, Machine							4	
-15	-	39391	DECAL							1	
-16	GD4455	36506	PANEL ASSEMBLY, Back							1	
-17	MS51957-25	MS51957-28	(ATTACHING PARTS) SCREW, Machine							4	
-18	MS535338-79	MS535338-79	WASHER, Lock							4	
-19	513D8-4-103	36520-0004	LOCKSPRING, Turnlock (72794 Part No. S3-150)							2	
-20	506C16-12	36518-0012	RIVET, Tubular (61007 Part No. 20159 1/8 in.)							4	
-21	515D3226	36526	PANEL							1	
-	GD4589	36512	CABLE ASSEMBLY, Special purpose (C-6717/APX)							1	
-	-	36512	CABLE ASSEMBLY, Special purpose (C-7483/APX)							1	
-22	MS24264R22 B55P	MS24264R22 B55P	CONNECTOR, Receptacle, electrical							1	
-23	MS51957-15	MS51957-15	(ATTACHING PARTS) SCREW, Machine							4	
-24	MS35649-44	MS35649-44	NUT, Hexagon							4	
-25	MS35338-78	MS35338-78	WASHER, Lock							4	
-26	527C810	36540	POST, Electrical-mechanical equipment							4	
-27	AN507C632R6	AN507C632R6	(ATTACHING PARTS) SCREW, Machine							4	
-28	576C169	-	SWITCH, Rotary (76854 Part No. 250994AF1)							1	
-28	-	36554	SWITCH, Rotary (76854 Part No. 261360AF1)							1	
-29	-	-	(ATTACHING PARTS) NUT, Hexagon (supplied w/ -28)							1	
-30	-	-	WASHER, Lock (supplied w/ -28)							1	
-31	576D176	-	SWITCH, Rotary (76854 Part No. 260020AF3)							1	
-31	-	36555	SWITCH, Rotary (76854 Part No. 261361AF3)							1	
-32	-	-	(ATTACHING PARTS) NUT, Hexagon (supplied w/ -31)							1	
-33	-	-	WASHER, Lock (supplied w/ -31)							1	
-34	MS25041-3	MS25041-3	LIGHT, Indicator							2	
-35	MS25237-327	MS25237-327	LAMP, Incandescent, 28-volt							2	
-36	-	-	BASE, Mounting (p/o -34)							2	
-37	MS25082-88	MS25082-88	(ATTACHING PARTS) NUT, Hexagon (supplied w/ -34)							2	

T.O. 12P4-2APX-142
 NAVAIR 16-35C6280-1
 TM 11-5641-268-25

TABLE 10-3. C-6717/APX AND C-7483/APX GROUP ASSEMBLY PARTS LIST-Continued

FIGURE & INDEX NUMBER	PART NUMBER (70117)	PART NUMBER (00781)	DESCRIPTION							UNITS PER ASSY	USABLE ON CODE
			1	2	3	4	5	6	7		
FO-5-38	AN936A716S	AN936A716S	.	.	WASHER, Lock (supplied w/ -34).	2	
-39	MS25082-B8	MS25082-B8	.	.	NUT, Hexagon (supplied w/ -34)	2	
-40	MS25125-C3	MS25125-C3	.	.	SWITCH, Toggle.	1	
			.	.	(ATTACHING PARTS)		
-	MS25082-B8	MS25082-B8	.	.	NUT, Hexagon (supplied w/ -40)	1	
-	AN936A716S	AN936A716S	.	.	WASHER, Lock (supplied w/ -40).	1	
-	MS25081-1	MS25081-1	.	.	WASHER, Key (supplied w/ -40)	1	
-	MS25082-B8	MS25082-B8	.	.	NUT, Hexagon (supplied w/ -40)	1	
-41	MS35059-21	MS35059-21	.	.	SWITCH, Toggle.	1	
			.	.	(ATTACHING PARTS)		
-	MS25082-B8	MS25082-B8	.	.	NUT, Hexagon (supplied w/ -41)	1	
-	AN936A716S	AN936A716S	.	.	WASHER, Lock (supplied w/ -41).	1	
-	MS25081-1	MS25081-1	.	.	WASHER, Key (supplied w/ -41)	1	
-	MS25082-B8	MS25082-B8	.	.	NUT, Hexagon (supplied w/ -41)	1	
-42	MS25201-5	MS25201-5	.	.	SWITCH, Toggle.	4	
			.	.	(ATTACHING PARTS)		
-	MS25082-B8	MS25082-B8	.	.	NUT, Hexagon (supplied w/ -42)	4	
-	AN936A716S	AN936A716S	.	.	WASHER, Lock (supplied w/ -42).	4	
-	MS25081-1	MS25081-1	.	.	WASHER, Key (supplied w/ -42)	4	
-	MS25082-B8	MS25082-B8	.	.	NUT, Hexagon (supplied w/ -42)	4	
-43	MS35059-31	MS35059-31	.	.	SWITCH, Toggle.	1	
			.	.	(ATTACHING PARTS)		
-	MS25082-B8	MS25082-B8	.	.	NUT, Hexagon (supplied w/ -43)	1	
-	AN936A716S	AN936A716S	.	.	WASHER, Lock (supplied w/ -43).	1	
-	MS25081-1	MS25081-1	.	.	WASHER, Key (supplied w/ -43)	1	
-	MS25082-B8	MS25082-B8	.	.	NUT, Hexagon (supplied w/ -43)	1	
-44	MS35058-31	MS35058-31	.	.	SWITCH, Toggle.	1	
			.	.	(ATTACHING PARTS)		
-	MS25082-B8	MS25082-B8	.	.	NUT, Hexagon (supplied w/ -44)	1	
-	AN936A716S	AN936A716S	.	.	WASHER, Lock (supplied w/ -44).	1	
-	MS25081-1	MS25081-1	.	.	WASHER, Key (supplied w/ -44)	1	
-	MS25082-B8	MS25082-B8	.	.	NUT, Hexagon (supplied w/ -44)	1	
-45	588B233	-	.	.	CONNECTOR, Receptacle, electrical	1	
			.	.	(94375 Part No. RFO2728A)		
			.	.	(ATTACHING PARTS)		
-46	No Number	-	.	.	NUT, Hexagon (supplied w/ -45)	1	
-47	AN936A516B	-	.	.	WASHER, Lock (supplied w/ -45).	1	
-48	No Number	-	.	.	TERMINAL, Lug (supplied w/ -45)	1	
-49	AN960C516L	-	.	.	WASHER, Flat (supplied w/ -45)	1	
-	No Number	-	.	.	WASHER, Bow (supplied w/ -45)	1	
-	AN960C616L	-	.	.	WASHER, Flat (supplied w/ -45)	1	
-45	-	MS90335-4	.	.	CONNECTOR, Receptacle, electrical	1	
			.	.	(ATTACHING PARTS)		
-46	-	MS52029	.	.	NUT, Hexagon (supplied w/ -45)	1	
-47	-	AN936A516S	.	.	WASHER, Lock (supplied w/ -45).	1	
-48	-	39067	.	.	TERMINAL, Lug (79963 Part No. 80)	1	
-49	-	MS15795-812	.	.	WASHER, Flat	1	
-50	-	39065	.	.	BUSHING	1	
-51	515B3222	36522	.	.	BRACKET, Angle.	1	
			.	.	(ATTACHING PARTS)		
-52	AN507C440R4	AN507C440R4	.	.	SCREW, Machine	2	
-53	MS35649-44	MS35649-44	.	.	NUT, Hexagon.	2	
-54	MS35338-79	MS35338-79	.	.	WASHER, Lock	2	
-55	MS51957-11	MS51957-12	.	.	SCREW, Machine	6	
-56	509C4-5	8927-0004	.	.	TERMINAL, Lug	2	
-57	MS35338-78	MS35338-78	.	.	WASHER, Lock	4	
-58	GD4460-1	36510-6001	.	.	SWITCH ASSEMBLY (C-6717/APX)	5	
			.	.	(See Figure 10-1)		
-58	-	36510-7001	.	.	SWITCH ASSEMBLY (C-7483/APX)	5	
			.	.	(See Figure 10-1)		
-59	GD4460-2	36510-6002	.	.	SWITCH ASSEMBLY (C-6717/APX)	1	
			.	.	(See Figure 10-1)		
-59	-	36510-7002	.	.	SWITCH ASSEMBLY (C-7483/APX)	1	
			.	.	(See Figure 10-1)		
			.	.	(ATTACHING PARTS)		
-60	AN507C440R4	AN507C440R4	.	.	SCREW, Machine (supplied w/ -58 and -59).	12	

TABLE 10-3. C-6717/APX AND C-7483/APX GROUP ASSEMBLY PARTS LIST-Continued

FIGURE & INDEX NUMBER	PART NUMBER (70117)	PART NUMBER (00781)	DESCRIPTION							UNITS PER ASSY	USABLE ON CODE
			1	2	3	4	5	6	7		
FO-5-61	GD4551	36507	1	
-61	-	36507	1	
-62	501A40-5	36751-0005	4	
-63	501A40-6	36571-0006	1	
-64	501A40-7	36751-0007	1	
-65	501A40-8	36571-0008	1	
-66	502D18-91	36572-0462	4	
-67	515D3266	36524	1	
-67	-	36524	1	

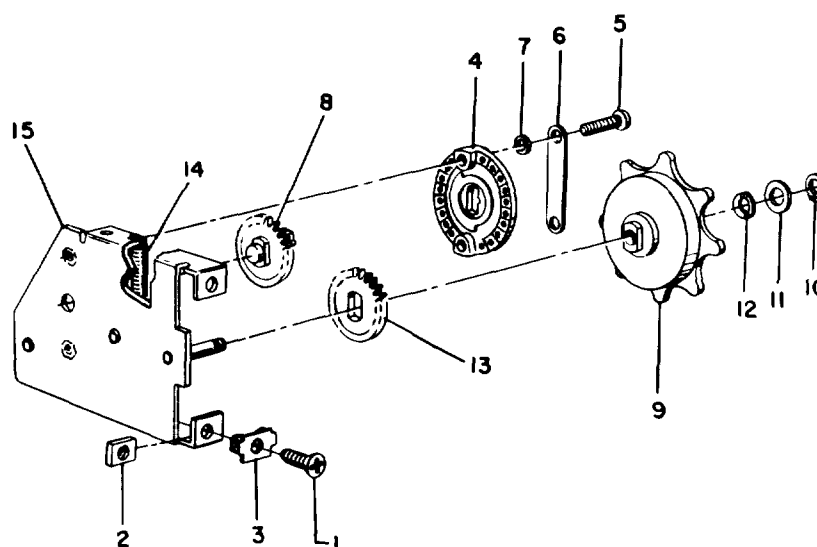

Figure 10-1. Switch Assembly, Exploded View

TABLE 10-4. SWITCH ASSEMBLY GROUP ASSEMBLY PARTS LIST

FIGURE & INDEX NUMBER	PART NUMBER (70117)	PART NUMBER (00781)	DESCRIPTION							UNITS PER ASSY	USABLE ON CODE
			1	2	3	4	5	6	7		
10-1-	GD4460-1	36510-0001	SWITCH ASSEMBLY [C-6280(P)/APX, NHA See 56, Figure FO-3] [C-6280A(P)/APX, NHA See 59, Figure FO-4]							REF	
10-1-	GD4460-2	36510-0002	SWITCH ASSEMBLY [C-6280(P)/APX, NHA See 57, Figure FO-3] [C-6280A(P)/APX, NHA See 60, Figure FO-4]							REF	
10-1-	GD4460-1	36510-6001	SWITCH ASSEMBLY [C-6717/APX, NHA See 58, Figure FO-5]							REF	
10-1-	GD4460-2	36510-6002	SWITCH ASSEMBLY [C-6717/APX, NHA See 59, Figure FO-5]							REF	
10-1-	-	36510-7001	SWITCH ASSEMBLY [C-7483/APX, NHA See 58, Figure FO-5]							REF	
10-1-	-	36510-7002	SWITCH ASSEMBLY [C-7483/APX, NHA See 59, Figure FO-5]							REF	
-1	MS24693C24	MS24693C24	2	
-2	502B123	36513	2	
-3	518B338	36528	2	
-4	576C168	-	1	
-4	-	36553	1	
-5	MS51957-5	MS51957-5	2	

T.O. 12P4-2APX-142
 NAVAIR 15-35C6280-1
 TM 11-5841-268-25

TABLE 10-4. SWITCH ASSEMBLY GROUP ASSEMBLY PARTS LIST-Continued

FIGURE & INDEX NUMBER	PART NUMBER (70117)	PART NUMBER (00781)	DESCRIPTION							UNITS PER ASSY	USABLE ON CODE
			1	2	3	4	5	6	7		
10-1-6	518C337	36529	1	
-7	505B21	36517	2	
-8	GB4458	36501	1	
-9	GD4459-1	36509-1001	1	
-9	GD4459-1	36509-6001	1	
-9	—	36509-7001	1	
-9	GD4459-2	36509-1002	1	
-9	GD4459-2	36509-6002	1	
-9	—	36509-7002	1	
-10	MS16624-12	MS16624-12	1	
-11	504C2	36516-0075	AR	
-12	504C1-19	36515-0019	1	
-13	530B283	36543-0001	1	
-14	519B77-3	36530-0003	1	
-15	GC4453	36503	1	

TABLE 10-5. NUMERICAL INDEX

Part Number	Fig. & Index No.	Qty Per Art	Air Force		Navy		Part Number	Fig. & Index No.	Qty Per Art	Air Force		Navy	
			Source Code	Repair Code	Source Code	Acct/Recover Code				Source Code	Repair Code	Source Code	Acct/Recover Code
AN507C440R5	FO-4-33	4	P1	NS	P1	C	PF3 1-2 38	FO-3-61	1	P1	NS	P1	C
AN935B6	FO-4-14	4					PS3 1-2	FO-3-62	1	P1	NS	P1	C
AN936A516B	FO-5-47	1					S3-150	FO-3-20	2	P1	NS	P1	C
AN936A516S	FO-5-47	1					WASHER, Bow						
AN936A716S	FO-3-39	2					(Supl/w 588B233)						
AN960C516L	FO-5-49	1	P1	NS			WASHER, Lock	FO-3-31	1				
AN960C616L							12NCFMA2-62	FO-4-70	4				
(Supl/w 588B233)							20159-1/8 in.	FO-3-21	4	P1	NS		
A3-20	FO-3-2	2	P1	NS	P1	C	250994AF1	FO-3-29	1	P1	NS	P1	C
A7077-5	FO-3-9	5	P1	NS	P1	C	251876AM	10-1-4	6	P1	NS	P1	C
BASE, Mounting	FO-3-37	2					260020AF3	FO-3-32	1	P1	NS	P1	C
C-6280A(P)/APX	FO-4-	1	P1	XF			261360AF1	FO-3-29	1	P1	NS	P1	C
C-6280(P)/APX	FO-3-	1	P1	XF	P1	R	261361AF3	FO-3-32	1	P1	NS	P1	C
C-6717/APX	FO-5-	1	P1	XF			261362AM	10-1-4	6	P1	NS	P1	C
C-7483/APX	FO-5-	1	P1	XF			28665-0012	10-1-10	6	X1		P1	C
GB4458	10-1-8	6	X1		P1	C	29901-0044	FO-3-25	4	P1	NS		
GC4453	10-1-15	6	X1		P1	C	30469-0001	FO-3-10	5	P1	NS	P1	C
GD4461	FO-3-	1	P1	XF	P1	R	30469-0002	FO-3-10	5	P1	NS	P1	C
GD4455	FO-3-17	1	A		AF		31014-4016	10-1-1	12	P1	NS		
GD4456	FO-3-59	1	A		AF		31014-6024	FO-3-28	4	P1	NS	P1	C
GD4457	FO-3-1	1	A		AF		3502-05-16	10-1-12	6	X1		P1	MO
GD4459-1	10-1-9	5	X1		P1	C	36500	FO-3-	1	P1	XF	P1	R
GD4459-2	10-1-9	1	X1		P1	C	36501	10-1-8	6	X1		P1	R
GD4460-1	10-1-	5	P1	NS	AF		36503	10-1-15	6	X1		P1	C
GD4460-2	10-1-	1	P1	NS	AF		36506	FO-3-17	1	A		AF	
GD4462	FO-3-	1			AO		36507	FO-3-59	1	A		AF	
GD4492	FO-3-	1	M		AF		36508	FO-3-1	1	A		AF	
GD4548	FO-5-	1	P1	XF			36509-1001	10-1-9	5	X1		P1	C
GD4550	FO-5-	1					36509-1002	10-1-9	1	X1		P1	C
GD4551	FO-5-61	1	A		AF		36509-6001	10-1-9	5	X1		P1	C
GD4589	FO-5-						36509-6002	10-1-9	1	X1		P1	C
GD4937	FO-4-						36509-7001	10-1-9	5	X1		P1	C
GH3	FO-3-3	2	P1	NS	P1	C	36509-7002	10-1-9	1	X1		P1	C
LUG, Solder	FO-5-48	1					36510-0001	10-1-	5	P1	NS	AF	
MS15795-812	FO-5-49	1	P1	NS			36510-0002	10-1-	1	P1	NS	AF	
MS16624-12	10-1-10	6	X1		P1	C	36510-6001	10-1-	5	P1	NS		
MS24264R22B55PX	FO-3-23	1	P1	NS			36510-6002	10-1-	1	P1	NS		
MS24693C24	10-1-1	12	P1	NS	P1	C	36510-7001	10-1-	5	P1	NS		
MS24693C26	FO-3-28	4	P1	NS	P1	C	36510-7002	10-1-	1	P1	NS		
(MS25010)-11A	FO-3-9	5	P1	NS	P1	C	36511	FO-3-	1			AO	
(MS25010)-12A	FO-3-9	5	P1	NS	P1	C	36512	FO-3-	1	M		AF	
MS25010A	FO-3-46	5	P1	NS			36513	10-1-2	12	M		MO	
MS25041-3	FO-3-35	2	P1	NS			36515-0019	10-1-12	6	X1		MO	
MS25081-1							36516-0075	10-1-11	AR	X1			
(Supl/w							36518-0012	FO-3-21	4	P1	NS	N	
MS25125-C3)							36520-0004	FO-3-20	2	P1	NS	P1	C
MS25082-88	FO-3-38	2					36520-0007	FO-3-3	2	P1	NS		
MS25125-C3	FO-3-41	1	P1	NS	P1	C	36520-0043	FO-3-2	2	P1	NS		
MS25201-5	FO-3-43	4	P1	NS	P1	C	36522	FO-3-49	1	M		MO	
MS25237-327	FO-3-10	5	P1	NS	P1	C	36524	FO-3-65	1	M1			
MS25237-328	FO-3-10	5	P1	NS	P1	C	36525	FO-3-4	1	M		MO	
MS35058-31	FO-3-45	1	P1	NS	P1	C	36526	FO-3-22	1	M		MO	
MS35059-21	FO-3-42	1	P1	NS			36528	10-1-3	12	M		MO	
MS35059-31	FO-3-44	1	P1	NS			36529	10-1-6	6	X1		MF	
MS35233-28	FO-3-12	4	P1	NS			36530-0003	10-1-14	6	X1		MF	
MS35338-135	FO-3-26	4	P1	NS			36531	FO-3-11	1	P1	NS	P1	C
MS35338-136	FO-3-19	4	P1	NS	P1	C	36533	FO-3-13	1	M1		MO	
MS35649-244	FO-3-25	4	P1	NS	P1	C	36534-0001	FO-3-15	1	M1		MO	
MS51021-32	FO-3-6	2	P1	NS	P1	C	36540	FO-3-27	4	M		MO	
MS51967-1	FO-3-14	4	P1	NS			36543-0001	10-1-13	6	M1		MO	
MS51957-11	FO-3-53	6	P1	NS	P1	C	36546-0001	FO-3-5	1	P1	NS	P1	C
MS51957-12	FO-3-53	6	P1	NS	P1	C	36546-0002	FO-3-7	1	P1	NS	P1	C
MS51957-13	FO-4-62	6					36546-6001	FO-5-5	1	P1	NS		
MS51957-15	FO-3-24	4					36546-6002	FO-5-7	1	P1	NS		
MS51957-25	FO-3-18	4	P1	NS	P1	C	36546-7001	FO-5-5	1	P1	NS		
MS51957-27	FO-4-20	4					36546-7002	FO-5-7	1	P1	NS		
MS51957-28	FO-3-18	4	P1	NS	P1	C	36553	10-1-4	6	P1	NS	P1	C
MS51957-5	10-1-5	12	P1	NS	P1	C	36554	FO-3-29	1	P1	NS	P1	C
MS52029	FO-5-46	1					36555	FO-3-32	1	P1	NS	P1	C
MS90335-4	FO-5-45	1	P1	NS			36556-0004	FO-3-9	5	P1	NS		
NUT, Hexagon	FO-4-36	1					36556-0005	FO-3-46	5	P1	NS		
NUT, Hexagon	FO-3-30	1					36557-0003	FO-3-35	2	P1	NS		
NUT, Hexagon	FO-5-46	1					36562-0005	FO-3-43	4	P1	NS	P1	C
PC3 1-2	FO-3-63	1	P1	NS	P1	C	36563-3003	FO-3-41	1	P1	NS	P1	C

T.O. 12P4-2APX-142
 NAVAIR 16-35C6260-1
 TM 11-5641-268-25

TABLE 10-5. NUMERICAL INDEX-Continued

Part Number	Fig. & Index No.	Qty Per Art	Air Force		Navy		Part Number	Fig. & Index No.	Qty Per Art	Air Force		Navy	
			Source Code	Repair Code	Source Code	Acct/Recover Code				Source Code	Repair Code	Source Code	Acct/Recover Code
36564-0031	FO-3-45	1	P1	NS	P1	C	501A40-6	FO-3-61	1	P1	NS	P1	C
36565-0021	FO-3-42	1	P1	NS			501A40-7	FO-3-62	1	P1	NS	P1	C
36565-0031	FO-3-44	1	P1	NS			501A40-8	FO-3-63	1	P1	NS	P1	C
36566-0001	FO-3-14	4	P1	NS			502B123	10-1-2	12	M		MO	
36566-0005	10-1-5	12	P1	NS			502D18-91	FO-3-64	4	P1	NS	P1	C
36566-0013	FO-4-62	6	P1	NS			504C1-19	10-1-12	6	X1		MO	
36567-0078	FO-3-26	4	P1	NS			504C2	10-1-11	AR				
36567-0079	FO-3-19	4	P1	NS			505B21	10-1-7	12	X1		MF	
36568-0032	FO-3-6	2	P1	NS			506C16-12	FO-3-21	4	P1	NS	N	
36570-0028	FO-3-12	4	P1	NS			509C4-5	FO-3-54	2				
36571-0005	FO-3-60	4	A		AF		513D8-7	FO-3-3	2	P1	NS	P1	C
36571-0006	FO-3-61	1	P1	NS	P1	C	513D8-4-103	FO-3-20	2	P1	NS	P1	C
36571-0007	FO-3-62	1	P1	NS	P1	C	513D8-43-103	FO-3-2	2	P1	NS	P1	C
36571-0008	FO-3-63	1	P1	NS	P1	C	515B3222	FO-3-49	1	M		MO	
36572-0462	FO-3-64	4	P1	NS	P1	C	515D3224	FO-3-65	1	M1			
36576	FO-3-9	5	P1	NS	P1	C	515D3225	FO-3-4	1	M		MO	
36577	FO-3-23	1	P1	NS			515D3226	FO-3-22	1	M		MO	
36584	FO-4-34	1					518B338	10-1-3	2	M		MO	
36586	FO-4-35	1					518C337	10-1-6	1	X1		MF	
36587	FO-4-50	1					519B77-3	10-1-14	1	X1		MF	
36589	FO-4-1	1					521D53	FO-3-11	1	P1	NS	P1	C
36592	FO-4-4	1					521D55	FO-5-9	1	P1	NS		
38270	FO-4-	1					526B516	FO-4-15	1				
38272	FO-4-11	1					526C454	FO-3-15	1	M1		MO	
38273	FO-4-	1					526C457	FO-3-13	1	M1		MO	
38274	FO-4-65	1					526C478	FO-5-11	1	M1		MO	
38277	FO-4-19	1					527C810	FO-3-27	4	M		MO	
38278	FO-4-24	1					530B283	10-1-13	6	M1		MO	
39050-6000	FO-5-	1	P1	XF			533C326-1	FO-3-5	1	P1	NS	P1	C
39050-7000	FO-5-	1	P1	XF			533C326-2	FO-3-7	1	P1	NS	P1	C
39053-0004	FO-5-45	1	P1	NS			576C168	10-1-4	6	P1	NS	P1	C
39054-6000	FO-5-9	1	P1	NS			576C169	FO-3-29	1	P1	NS	P1	C
39054-7000	FO-5-9	1	P1	NS			576D176	FO-3-32	1	P1	NS	P1	C
39055-0002	FO-5-11	1	M1		MO		581A2-4	FO-3-36	2	P1	NS	P1	C
39056	FO-5-11	1	M1		MO		582A11-12	FO-3-9	5	P1	NS	P1	C
39059-6000	FO-5-	1					582A11-4	FO-3-9	5	P1	NS	P1	C
39059-7000	FO-5-	1					582A11-5	FO-3-46	5	P1	NS		
39065	FO-5-50	1	P1	NS			582B12-3	FO-3-35	2	P1	NS		
39067	FO-5-48	1	P1	NS			588B233	FO-5-45	1	P1	NS	P1	C
39071-0812	FO-5-49	1	P1	NS			60327	FO-3-9	5	P1	NS		
39391	FO-5-15	1	M1		MO		79NCFMA2-62	FO-3-64	4	P1	NS	P1	C
4041	FO-4-13	4					80	FO-5-48	1	P1	NS		
48327	FO-3-46	5	P1	NS			8927-0004	FO-3-54	2				
501A40-5	FO-3-60	4	A		AF		8948-0262	FO-4-70					

TABLE 10-5. NUMERICAL INDEX

Part Number	Fig. & Index No.	Qty Per Art	Air Force		Navy		Part Number	Fig. & Index No.	Qty Per Art	Air Force		Navy	
			Source Code	Repair Code	Source Code	Acct/Recover Code				Source Code	Repair Code	Source Code	Acct/Recover Code
AN507C440R5	FO-4-33	4	P1	NS	P1	C	PF3 1-2 38	FO-3-61	1	P1	NS	P1	C
AN935B6	FO-4-14	4					PS3 1-2	FO-3-62	1	P1	NS	P1	C
AN936A516B	FO-5-47	1					S3-150	FO-3-20	2	P1	NS	P1	C
AN936A516S	FO-5-47	1					WASHER, Bow (Supl/w 588B233)						
AN936A716S	FO-3-39	2					WASHER, Lock						
AN960C516L	FO-5-49	1	P1	NS			12NCFMA2-62	FO-3-31	1				
AN960C616L							20159-1/8 in.	FO-4-70	4				
(Supl/w 588B233)							250994AF1	FO-3-21	4	P1	NS		
A3-20	FO-3-2	2	P1	NS	P1	C	251876AM	FO-3-29	1	P1	NS	P1	C
A7077-5	FO-3-9	5	P1	NS	P1	C	260020AF3	10-1-4	6	P1	NS	P1	C
BASE, Mounting	FO-3-37	2					261360AF1	FO-3-32	1	P1	NS	P1	C
C-6280A(P)/APX	FO-4-	1	P1	XF			261361AF3	FO-3-29	1	P1	NS	P1	C
C-6280(P)/APX	FO-3-	1	P1	XF	P1	R	261362AM	FO-3-32	1	P1	NS	P1	C
C-6717/APX	FO-5-	1	P1	XF			28665-0012	10-1-4	6	P1	NS	P1	C
C-7483/APX	FO-5-	1	P1	XF			29901-0044	10-1-10	6	X1		P1	C
GB4458	10-1-8	6	X1		P1	C	30469-0001	FO-3-25	4	P1	NS		
GC4453	10-1-15	6	X1		P1	C	30469-0002	FO-3-10	5	P1	NS	P1	C
GD4451	FO-3-	1	P1	XF	P1	R	31014-4016	FO-3-10	5	P1	NS	P1	C
GD4455	FO-3-17	1	A		AF		31014-6024	10-1-1	12	P1	NS		
GD4456	FO-3-59	1	A		AF		3502-05-16	FO-3-28	4	P1	NS		
GD4457	FO-3-1	1	A		AF		36500	10-1-12	6	X1		MO	
GD4459-1	10-1-9	5	X1		P1	C	36501	FO-3-	1	P1	XF	P1	R
GD4459-2	10-1-9	1	X1		P1	C	36501	10-1-8	6	X1		P1	C
GD4460-1	10-1-	5	P1	NS	AF		36503	10-1-15	6	X1		P1	C
GD4460-2	10-1-	1	P1	NS	AF		36506	FO-3-17	1	A		AF	
GD4462	FO-3-	1			AO		36507	FO-3-59	1	A		AF	
GD4492	FO-3-	1	M		AF		36508	FO-3-1	1	A		AF	
GD4548	FO-5-	1	P1	XF			36509-1001	10-1-9	5	X1		P1	C
GD4550	FO-5-	1					36509-1002	10-1-9	1	X1		P1	C
GD4551	FO-5-61	1	A		AF		36509-6001	10-1-9	5	X1		P1	C
GD4589	FO-5-						36509-6002	10-1-9	1	X1		P1	C
GD4937	FO-4-						36509-7001	10-1-9	5	X1		P1	C
GH3	FO-3-3	2	P1	NS	P1	C	36509-7002	10-1-9	1	X1		P1	C
LUG, Solder	FO-5-48	1					36510-0001	10-1-	5	P1	NS	AF	
MS15795-812	FO-5-49	1	P1	NS			36510-0002	10-1-	1	P1	NS	AF	
MS16624-12	10-1-10	6	X1		P1	C	36510-6001	10-1-	5	P1	NS		
MS24264R22B55P	FO-3-23	1	P1	NS			36510-6002	10-1-	1	P1	NS		
MS24693C24	10-1-1	12	P1	NS	P1	C	36510-7001	10-1-	5	P1	NS		
MS24693C26	FO-3-28	4	P1	NS	P1	C	36510-7002	10-1-	1	P1	NS		
(MS25010)-11A	FO-3-9	5	P1	NS	P1	C	36511	FO-3-	1			AO	
(MS25010)-12A	FO-3-9	5	P1	NS	P1	C	36512	FO-3-	1	M		AF	
MS25010A	FO-3-46	5	P1	NS			36513	10-1-2	12	M		MO	
MS25041-3	FO-3-35	2	P1	NS			36515-0019	10-1-12	6	X1		MO	
MS25081-1							36516-0075	10-1-11	AR	X1			
(Supl/w							36518-0012	FO-3-21	4	P1	NS	N	
MS25125-C3)							36520-0004	FO-3-20	2	P1	NS	P1	C
MS25082-88	FO-3-38	2					36520-0007	FO-3-3	2	P1	NS		
MS25125-C3	FO-3-41	1	P1	NS	P1	C	36520-0043	FO-3-2	2	P1	NS		
MS25201-5	FO-3-43	4	P1	NS	P1	C	36522	FO-3-49	1	M		MO	
MS25237-327	FO-3-10	5	P1	NS	P1	C	36524	FO-3-65	1	M1			
MS25237-328	FO-3-10	5	P1	NS	P1	C	36525	FO-3-4	1	M		MO	
MS35058-31	FO-3-45	1	P1	NS	P1	C	36526	FO-3-22	1	M		MO	
MS35059-21	FO-3-42	1	P1	NS			36528	10-1-3	12	M		MO	
MS35059-31	FO-3-44	1	P1	NS			36529	10-1-6	6	X1		MF	
MS35233-28	FO-3-12	4	P1	NS			36530-0003	10-1-14	6	X1		MF	
MS35338-135	FO-3-26	4	P1	NS			36531	FO-3-11	1	P1	NS	P1	C
MS35338-136	FO-3-19	4	P1	NS	P1	C	36533	FO-3-13	1	M1		MO	
MS35649-244	FO-3-25	4	P1	NS	P1	C	36534-0001	FO-3-15	1	M1		MO	
MS51021-32	FO-3-6	2	P1	NS	P1	C	36540	FO-3-27	4	M		MO	
MS51957-1	FO-3-14	4	P1	NS			36543-0001	10-1-13	6	M1		MO	
MS51957-11	FO-3-53	6	P1	NS	P1	C	36546-0001	FO-3-5	1	P1	NS	P1	C
MS51957-12	FO-3-53	6	P1	NS	P1	C	36546-0002	FO-3-7	1	P1	NS	P1	C
MS51957-13	FO-4-62	6					36546-6001	FO-5-5	1	P1	NS		
MS51957-15	FO-3-24	4					36546-6002	FO-5-7	1	P1	NS		
MS51957-25	FO-3-18	4	P1	NS	P1	C	36546-7001	FO-5-5	1	P1	NS		
MS51957-27	FO-4-20	4					36546-7002	FO-5-7	1	P1	NS		
MS51957-28	FO-3-18	4	P1	NS	P1	C	36553	10-1-4	6	P1	NS	P1	C
MS51957-5	10-1-5	12	P1	NS	P1	C	36554	FO-3-29	1	P1	NS	P1	C
MS52029	FO-5-46	1					36555	FO-3-32	1	P1	NS	P1	C
MS90335-4	FO-5-45	1	P1	NS			36556-0004	FO-3-9	5	P1	NS		
NUT, Hexagon	FO-4-36	1					36556-0005	FO-3-46	5	P1	NS		
NUT, Hexagon	FO-3-30	1					36557-0003	FO-3-35	2	P1	NS		
NUT, Hexagon	FO-5-46	1					36562-0005	FO-3-43	4	P1	NS	P1	C
PC3 1-2	FO-3-63	1	P1	NS	P1	C	36563-3003	FO-3-41	1	P1	NS	P1	C

T.O. 12P4-2APX-142
 NAVAIR 16-35C6280-1
 TM 11-5841-268-25

TABLE 10-5. NUMERICAL INDEX-Continued

Part Number	Fig. & Index No.	Qty Per Art	Air Force		Navy		Part Number	Fig. & Index No.	Qty Per Art	Air Force		Navy	
			Source Code	Repair Code	Source Code	Acct/Recover Code				Source Code	Repair Code	Source Code	Acct/Recover Code
36564-0031	FO-3-45	1	P1	NS	P1	C	501A40-6	FO-3-61	1	P1	NS	P1	C
36565-0021	FO-3-42	1	P1	NS			501A40-7	FO-3-62	1	P1	NS	P1	C
36565-0031	FO-3-44	1	P1	NS			501A40-8	FO-3-63	1	P1	NS	P1	C
36566-0001	FO-3-14	4	P1	NS			502B123	10-1-2	12	M		MO	
36566-0005	10-1-5	12	P1	NS			502D18-91	FO-3-64	4	P1	NS	P1	C
36566-0013	FO-4-62	6	P1	NS			504C1-19	10-1-12	6	X1		MO	
36567-0078	FO-3-26	4	P1	NS			504C2	10-1-11	AR				
36567-0079	FO-3-19	4	P1	NS			505B21	10-1-7	12	X1		MF	
36568-0032	FO-3-6	2	P1	NS			506C16-12	FO-3-21	4	P1	NS	N	
36570-0028	FO-3-12	4	P1	NS			509C4-5	FO-3-54	2				
36571-0005	FO-3-60	4	A		AF		513D8-7	FO-3-3	2	P1	NS	P1	C
36571-0006	FO-3-61	1	P1	NS	P1	C	513D8-4-103	FO-3-20	2	P1	NS	P1	C
36571-0007	FO-3-62	1	P1	NS	P1	C	513D8-43-103	FO-3-2	2	P1	NS	P1	C
36571-0008	FO-3-63	1	P1	NS	P1	C	515B3222	FO-3-49	1	M		MO	
36572-0462	FO-3-64	4	P1	NS	P1	C	515D3224	FO-3-65	1	M1			
36576	FO-3-9	5	P1	NS	P1	C	515D3225	FO-3-4	1	M		MO	
36577	FO-3-23	1	P1	NS			515D3226	FO-3-22	1	M		MO	
36584	FO-4-34	1					518B338	10-1-3	2	M		MO	
36586	FO-4-35	1					518C337	10-1-6	1	X1		MF	
36587	FO-4-50	1					519B77-3	10-1-14	1	X1		MF	
36589	FO-4-1	1					521D53	FO-3-11	1	P1	NS	P1	C
36592	FO-4-4	1					521D55	FO-5-9	1	P1	NS		
38270	FO-4-	1					526B516	FO-4-15	1				
38272	FO-4-11	1					526C454	FO-3-15	1	M1		MO	
38273	FO-4-	1					526C457	FO-3-13	1	M1		MO	
38274	FO-4-65	1					526C478	FO-5-11	1	M1		MO	
38277	FO-4-19	1					527C810	FO-3-27	4	M		MO	
38278	FO-4-24	1					530B283	10-1-13	6	M1		MO	
39050-6000	FO-5-	1	P1	XF			533C326-1	FO-3-5	1	P1	NS	P1	C
39050-7000	FO-5-	1	P1	XF			533C326-2	FO-3-7	1	P1	NS	P1	C
39053-0004	FO-5-45	1	P1	NS			576C168	10-1-4	6	P1	NS	P1	C
39054-6000	FO-5-9	1	P1	NS			576C169	FO-3-29	1	P1	NS	P1	C
39054-7000	FO-5-9	1	P1	NS			576D176	FO-3-32	1	P1	NS	P1	C
39055-0002	FO-5-11	1	M1		MO		581A2-4	FO-3-36	2	P1	NS	P1	C
39056	FO-5-11	1	M1		MO		582A11-12	FO-3-9	5	P1	NS	P1	C
39059-6000	FO-5-	1					582A11-4	FO-3-9	5	P1	NS	P1	C
39059-7000	FO-5-	1					582A11-5	FO-3-46	5	P1	NS		
39065	FO-5-50	1	P1	NS			582B12-3	FO-3-35	2	P1	NS		
39067	FO-5-48	1	P1	NS			588B233	FO-5-45	1	P1	NS	P1	C
39071-0612	FO-5-49	1	P1	NS			80327	FO-3-9	5	P1	NS		
39391	FO-5-15	1	M1		MO		79NCFMA2-62	FO-3-64	4	P1	NS	P1	C
4041	FO-4-13	4					80	FO-5-48	1	P1	NS		
46327	FO-3-46	5	P1	NS			8927-0004	FO-3-54	2				
501A40-5	FO-3-60	4	A		AF		8948-0262	FO-4-70					

TABLE 10-6. REFERENCE DESIGNATION INDEX

REFERENCE DESIGNATION	FIGURE & INDEX NO.	PART NUMBER
DS201	FO-3-36 FO-4-45	MS25237-327
DS202	FO-5-35 FO-3-36 FO-4-45 FO-5-35	MS25237-327
DS203 thru DS207 E201	FO-3-10 FO-4-10 FO-5-9	MS25237-327 or MS25237-328 39054-6000 39054-7000 521D55 MS24264R22B55P
J201	FO-3-23 FO-4-25 FO-5-22 FO-5-45	MS90335-4 588B233 250994AF1 261360AF1 36554 576C169 250994AF1 261360AF1 36554 576C169 250994AF1 261360AF1 36554 576C169 260020AF3 261361AF3 36555 576C176 260020AF3 261361AF3 36555 576C176 260020AF3 261361AF3 36555 576C176 MS25125-C3
J202		
S201	FO-3-29 FO-4-30 FO-5-28	
S202	FO-3-32 FO-4-37 FO-5-31	
S203	FO-3-41 FO-4-51 FO-5-40	
S204	FO-3-42 FO-4-52 FO-5-41	MS35059-21
S205 thru S208 S209	FO-3-43 FO-4-53 FO-5-42 FO-3-44 FO-4-54 FO-5-43	MS25201-5 MS35059-31
S210	FO-3-45 FO-4-55 FO-5-44 10-1-4	MS35058-31
S211 thru S216		251876AM 261362AM 36553 576C168

APPENDIX A REFERENCES

Following is a list of references available to the repairman of the transponder set control:

(Air Force) T.O. 0-1-12	Index of Technical Manuals, Technical Bulletins,
(Navy) NAVSUP 2002, Section VIII	Technical Orders, Forms and Publications, Sup
(Army) DA Pam 3104 and 310-7	ply Manuals, Supply Bulletins, Lubrication Or-
	ders, Illustrated Parts Breakdown Manuals, and
	Modification Work Orders.
	Equipment Record Procedures.
(Air Force) AFTO Form 29/29A	
(Navy) NAVWEPS Form 13070/5	
(Army) TM 38-750	
(Army) SB 38-100	Preservation, Packaging and Packing Materials,
	Supplies, and Equipment Used by the Army.
(Army) TB 746-10	Field Instructions for Painting and Preserving
	Electronics Command Equipment.
(Army) TM 9-213	Painting Instructions for Field Use.
(Air Force) T.O. 12P4-2APX72-2	Receiver-Transmitter, Radio RT-859/APX-72.
(Navy) NAVSHIPS 0967-217-4010	
(Navy) NAVSHIPS 0967-217-4020	
(Army) TM 11-5895490-20	
(Air Force) T.O. 12P4-2APX-192	Test Set, Transponder Set TS-1843A/APX.
(Navy) NAVAIR 16-35TS1843-1	
(Air Force) T.O. 12P4-2APX64-2	Radio Receiver-Transmitters RT-727()/APX-64,
(Navy) NAVAIR 16-30APX64-3	RT-728()/APX-64, and RT-731()/APX-64.

APPENDIX B

(Army) BASIC ISSUE ITEMS

B-1. SCOPE.

B-2. This appendix lists items comprising an operable equipment and those required for installation, operation, or operator's maintenance for Control, Transponder Set C-6280A (P)/APX.

B-3. EXPLANATION OF COLUMNS.

B-4. SOURCE, MAINTENANCE, AND RECOVERABILITY CODES, COLUMN 1.

a. Source Code (S). The selection status and source for the listed item is the first code indicated in this column. The source code P applies to repair parts that are stocked in or supplied from GSA/DSA, or Army supply system, and authorized for use at indicated maintenance categories.

b. Maintenance Code (M). The lowest category of maintenance authorized to install the item is indicated by the second code in the column. The maintenance category code O indicates Organizational Maintenance.

c. Recoverability Code (R). The recovery code is the third code in the column. It indicates whether unserviceable items should be returned for recovery or salvage. The recoverability code R applies to repair parts and assemblies that are economically repairable at DSU and GSU activities and are normally furnished by supply on an exchangeable basis.

B-5. FEDERAL STOCK NUMBER, COLUMN 2. This column indicates the Federal stock number for the item.

B-6. DESCRIPTION, COLUMN 3. This column includes the Federal item name and any additional description of the item which may be required. A part number or other reference number is followed by the applicable five-digit Federal supply code for manufacturers. Usable on code column is not used.

B-7. UNIT OF MEASURE, COLUMN 4. The unit used as a basis of measure (e.g., ea. pr, ft, yd) is given in this column.

B-8. QUANTITY INCORPORATED IN UNIT, COLUMN 5. The total quantity of the item used in the equipment is given in this column.

B-9. QUANTITY FURNISHED WITH EQUIPMENT, COLUMN 6. This column lists the quantity of the item supplied for initial operation of the equipment and/or the quantities authorized to be kept on hand by the operator for maintenance of the equipment.

B-10. ILLUSTRATIONS, COLUMN 7.

a. Figure Number (a). The number of the illustration in which the item is shown is indicated in this column.

b. Item No. or Reference Designation (b). Not used.

BASIC ISSUE ITEMS

(1) SMR CODE	(2) FEDERAL STOCK NUMBER	(3) DESCRIPTION <small>Reference Number & Nfr Code</small>	(4) UNIT OF MEAS	(5) QTY INC IN UNIT	(6) QTY FURN WITH EQUIP	(7) ILLUSTRATIONS	
						(a) FIG. NO.	(b) ITEM NO. OR REFERENCE DESIGNATION
P - D - R	5895-089-4403	CONTROL, TRANSPONDER SET C-6280A(P)/APX: (This item is nonexpendable) TECHNICAL MANUAL TM 11-5841-268-25 Requisition through pinpoint account number if assigned; otherwise through nearest Adjutant General facility. For technical manuals the quantity indicates the maximum number of copies authorized for packing (or issue) with the equipment. Where a number of these equipments are concentrated in a small area, the quantity on hand may be reduced to the minimum actual requirements as determined by the Commanding Officer of the unit. NO PARTS AUTHORIZED FOR USER, OPERATOR, OR CREWMAN. NO ACCESSORIES, TOOLS, OR TEST EQUIPMENT ARE TO BE ISSUED WITH THIS EQUIPMENT. NO BASIC ISSUE ITEMS ARE MOUNTED IN OR ON THIS EQUIPMENT.	ea	1	1	1-1	

APPENDIX C

(Army) MAINTENANCE ALLOCATION

C-1. GENERAL.

This appendix provides a summary of the maintenance operations covered in the equipment literature for Control, Transponder Set C-6280A(P)/APX. It authorizes categories of maintenance for specific maintenance functions on repairable items and components and the tools and equipment required to perform each function. This appendix may be used as an aid in planning maintenance operations.

C-2. MAINTENANCE FUNCTIONS.

Maintenance functions will be limited to and defined as follows:

a. Inspect. To determine serviceability of an item by comparing its physical, mechanical, and electrical characteristics with established standards.

b. Test. To verify serviceability and to detect incipient electrical or mechanical failure by use of special equipment such as gages, meters, etc. This is accomplished with external test equipment and does not include operation of the equipment and operator type tests using internal meters or indicating devices.

c. Service. To clean, to preserve, to charge, and to add fuel, lubricants, cooling agents, and air. If it is desired that elements, such as painting and lubricating, be defined separately, they may be so listed.

d. Adjust. To rectify to the extent necessary to bring into proper operating range.

e. Adjust. To adjust two or more components or assemblies of an electrical or mechanical system so that their functions are properly synchronized. This does not include setting the frequency control knob of radio receivers or transmitters to the desired frequency.

f. Calibrate. To determine the corrections to be made in the readings of instruments or test equipment used in precise measurement. Consists of the comparison of two instruments, one of which is a certified standard of known accuracy, to detect and adjust any discrepancy in the accuracy of the instrument being compared with the certified standard

g. Install. To set up for use in an operational environment such as an encampment, site, or vehicle.

h. Replace. To replace unserviceable items with serviceable like items.

i. Repair. To restore an item to serviceable condition through correction of a specific failure or unserviceable condition. This function includes but is not limited to welding,

grinding, riveting, straightening, and replacement of parts other than the trial and error replacement of running spare type items such as fuses, lamps, or electron tubes.

j. Overhaul. Normally, the highest degree of maintenance performed by the Army. It consists of that maintenance necessary to restore an item to completely serviceable condition as prescribed by maintenance standards in technical publications for each item of equipment. Overhaul normally does not return an item to like new, zero mileage, or zero hour condition.

k. Rebuild. The highest degree of materiel maintenance. It consists of restoring equipment as nearly as possible to new condition in accordance with original manufacturing standards. Rebuild is performed only when required by operational considerations or other paramount factors and then only at the depot maintenance category. Rebuild reduces to zero the hours or miles the equipment, or component thereof, has been in use.

l. Symbols. The uppercase letter placed in the appropriate column indicates the lowest level at which that particular maintenance function is to be performed.

C-3. EXPLANATION OF FORMAT.

C-4. GROUP NUMBER, COLUMN 1. Column 1 lists group numbers, the purpose of which is to identify components, assemblies, subassemblies, and modules with the next higher assembly.

C-5. FUNCTIONAL GROUP, COLUMN 2. Column 2 lists the noun names of components, assemblies, subassemblies, and modules on which maintenance is authorized.

C-6. MAINTENANCE FUNCTIONS, COLUMN 3. Column 3 lists the maintenance category at which performance of the specific maintenance function is authorized. Authorization to perform a function at any category also includes authorization to perform that function at higher categories. The codes used represent the various maintenance categories as follows:

<i>Code</i>	<i>Maintenance Category</i>
C	Operator/Crew
O	Organizational Maintenance
F	Direct Support Maintenance
H	General Support Maintenance
D	Depot Maintenance

C-7. TOOLS AND TEST EQUIPMENT, COLUMN 4. Column 4 specifies, by code, those tools and test equipment required to perform the designated function. The numbers

T.O. 12P4-2APX-142
NAVAIR 16-35C6280-1
TM 11-5841-268-25

appearing in this column refer to specific tools and test equipment which are identified in the Tool and Test Equipment Requirements Chart (paragraph C-9).

C-8. REMARKS, COLUMN 5. Self-explanatory.

C-9. EXPLANATION OF FORMAT OF TOOL AND TEST EQUIPMENT REQUIREMENTS CHART.

C-10. TOOLS AND EQUIPMENT, COLUMN 1. The numbers in this column coincide with the numbers used in the tools and equipment column of the Maintenance Allocation Chart. The numbers indicate the applicable tool for the maintenance function.

C-11. MAINTENANCE CATEGORY, COLUMN 2. The codes in this column indicate the maintenance category normally allocated the facility.

C-12. NOMENCLATURE, COLUMN 3. This column lists tools, test, and maintenance equipment required to perform the maintenance functions.

C-13. FEDERAL STOCK NUMBER, COLUMN 4. This column lists the Federal stock number of the specific tool or test equipment.

C-14. TOOL NUMBER, COLUMN 5. Not used.

MAINTENANCE ALLOCATION CHART																
GROUP NUMBER	COMPONENT ASSEMBLY NOMENCLATURE	MAINTENANCE FUNCTIONS										TOOLS AND EQUIPMENT	REMARKS			
		INSPECT	TEST	SERVICE	ADJUST	ALIGN	CALIBRATE	INSTALL	REPLACE	REPAIR	OVERHAUL			REBUILD		
1	CONTROL, TRANSPONDER SET C-6280A(P)/APX	O	O												2 1 3 1, 3 1, 3	Visual inspection. Check operation. Black box. Continuity checks. Piece parts.

TOOL AND TEST EQUIPMENT REQUIREMENTS CHART

TOOLS AND EQUIPMENT	MAINTENANCE CATEGORY	NOMENCLATURE	FEDERAL STOCK NUMBER	REMARKS
1	F, H, D	MULTIMETER ME-26/U	6625-542-6707	
2	O	TOOL KIT TK-101/G	5180-064-5178	
3	F, H, D	TOOL KIT TK-100/G	5180-605-0079	

- NOTES:**
- indicates panel marking.
 - For wiring diagram, see Figure FO-2.
 - MASTER and MODE 4 CODE switches are shown in extreme counterclockwise position. Wafers are viewed from opposite the control knob.
 - Mode 1 reply-code switches are shown in code 73 position.
 - Mode 3/A reply-code switches are shown in code 7777 position.
 - Panel lights DS203 through DS207 and wires marked ●●● are part of C-6280(P)/APX and C-6280A(P)/APX only. For 6-volt panel lighting, MS25237-328 lamps are used; for 28-volt panel lighting, MS25237-327 lamps are used.
 - Embedded lamps E201, connectors J202 and P201, and wires marked +++ are part of C-6717/APX and C-7483/APX only.

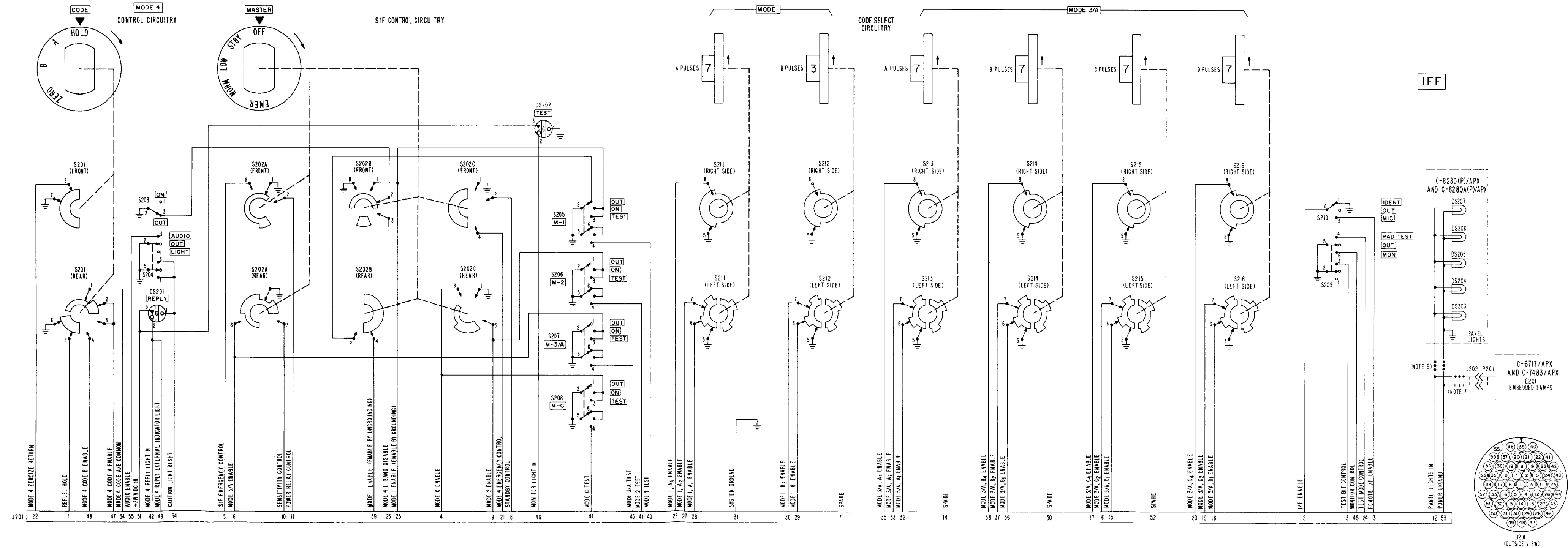

FO-1. Control, Transponder Set C-6280(P)/APX, C-6280A(P)/APX, C-6717/APX, and C-7483/APX, Schematic Diagram

NOTES:

- For schematic diagram, see Figure FO-1.
- Wires are No. 22 AWG, stranded copper, Teflon insulated.
- Wire colors shown are used in units manufactured under contracts AF33(657)-16648 and F33657-68-C-0785. Where different wire colors were used in units manufactured under contract AF33(657)-14550, wire numbers are marked with an asterisk (*); wire colors used in these units are as follows:

Wire No.	Color
3*	WHT-YEL-ORN
8*	RED-BLK
21*	BRN-RED
22*	RED-YEL
24*	WHT-BLU-ORN
34*	RED-GRN
41*	RED-BRN
42*	WHT-ORN-ORN
44*	RED-ORN
49*	WHT-ORN-ORN
55*	WHT-BLU-GRN
- Wires marked *** and XDS203 through XDS207 are part of C-6280(P)/APX and C-6280A(P)/APX only.
- Wires marked +++ and J202 are part of C-6717/APX and C-7483/APX only. Embedded panel lamps E201, P201, and associated wiring (all part of plastic light panel) are not shown.

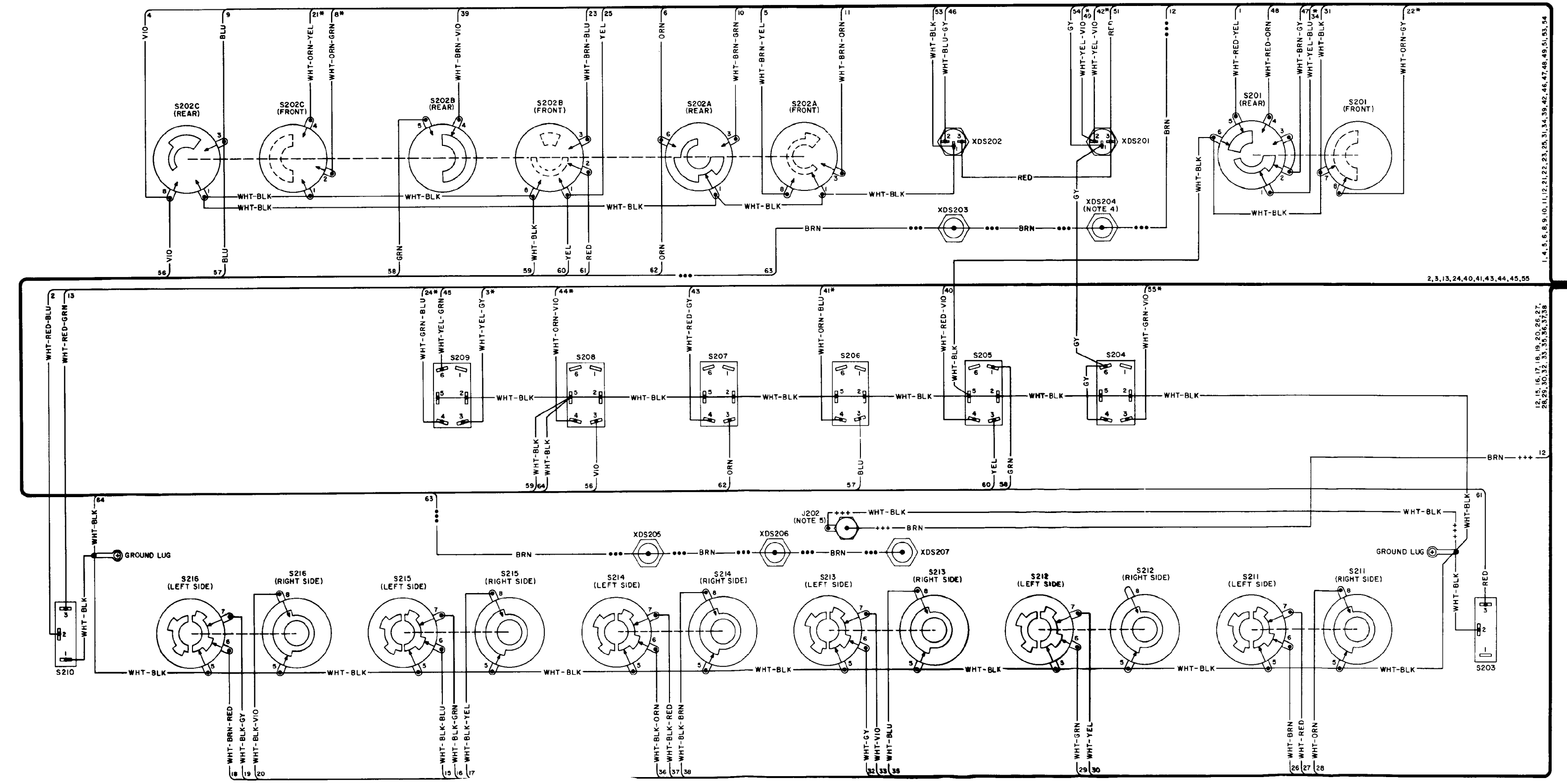

1	WHT-RED-YEL
2	WHT-RED-BLU
3	WHT-YEL-GY
4	VIO
5	WHT-BRN-YEL
6	ORN
7	SPARE
8	WHT-ORN-ORN
9	BLU
10	WHT-BRN-GRN
11	WHT-BRN-ORN
12	BRN
13	WHT-RED-GRN
14	SPARE
15	WHT-BLK-BLU
16	WHT-BLK-GRN
17	WHT-BLK-YEL
18	WHT-BRN-RED
19	WHT-BLK-GY
20	WHT-RED-VIO
21	WHT-ORN-YEL
22	WHT-ORN-GY
23	WHT-BRN-BLU
24	WHT-ORN-BLU
25	YEL
26	WHT-BRN
27	WHT-RED
28	WHT-ORN
29	WHT-GRN
30	WHT-YEL
31	WHT-BLK
32	WHT-GY
33	WHT-VIO
34	WHT-YEL-BLU
35	WHT-BLU
36	WHT-BLK-ORN
37	WHT-BLK-RED
38	WHT-BLK-BRN
39	WHT-BRN-VIO
40	WHT-RED-VIO
41	WHT-ORN-BLU
42	WHT-YEL-VIO
43	WHT-RED-GY
44	WHT-ORN-VIO
45	WHT-YEL-GRN
46	WHT-BLU-GY
47	WHT-BRN-GY
48	WHT-RED-ORN
49	WHT-YEL-VIO
50	SPARE
51	RED
52	SPARE
53	WHT-BLK
54	GY
55	WHT-GRN-VIO

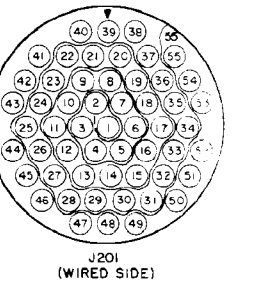

FO-2. Control, Transponder Set C-6280(P)/APX, C-6280A(P)/APX, C-6717/APX, and C-7483/APX, Wiring Diagram

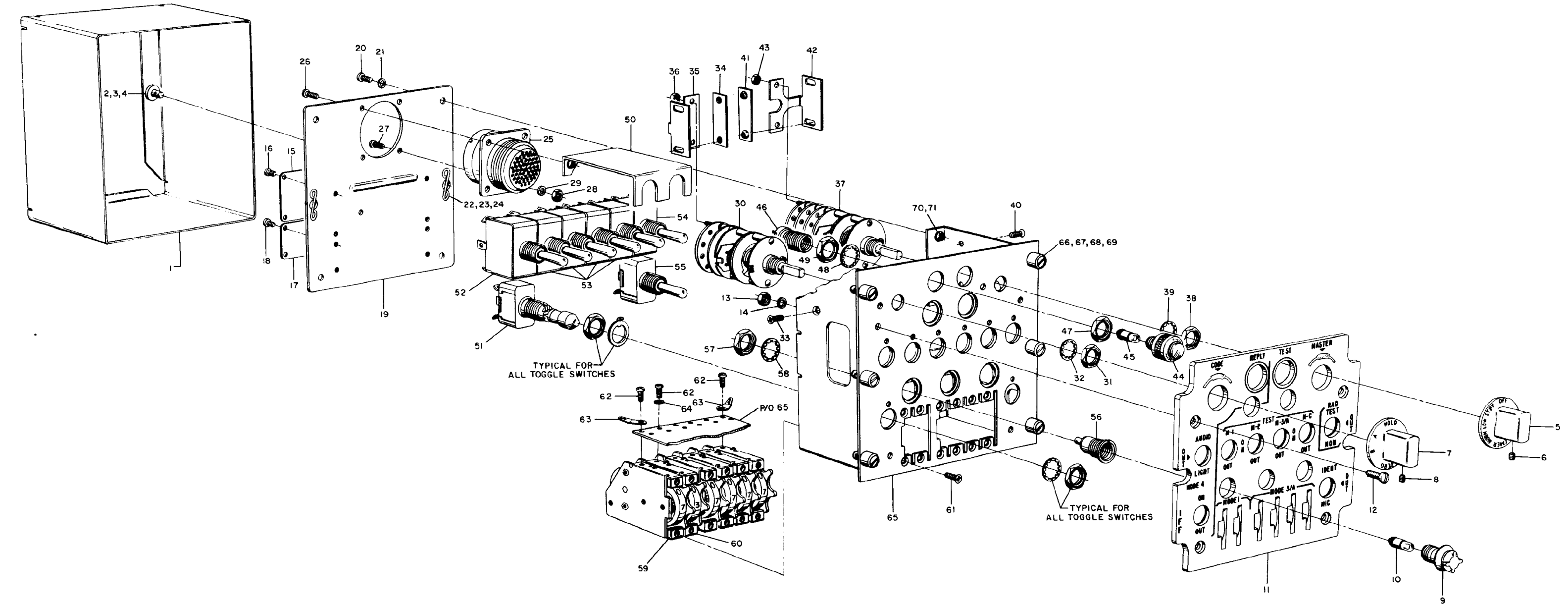

FO-4. Control, Transponder Set C-6280A(P)/APX, Exploded View

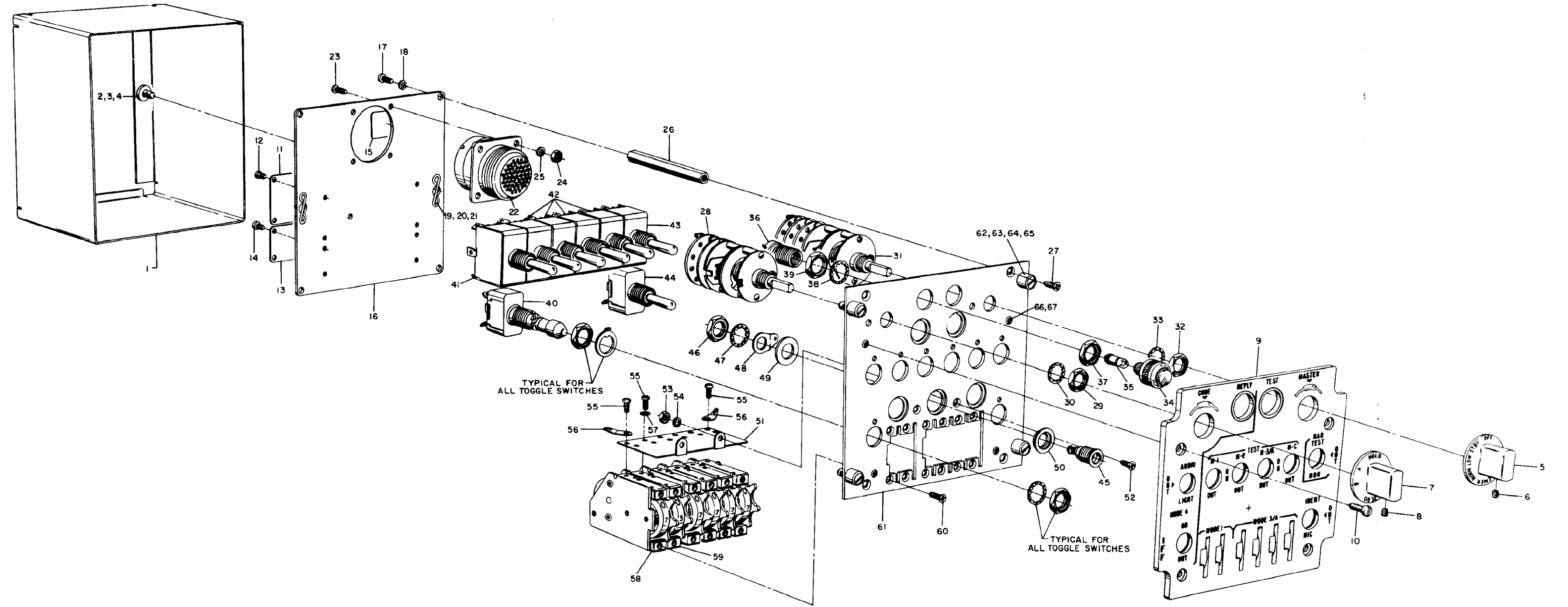

FO-5. Control, Transponder Set C-6717/APX and C-7483/APX,
Exploded View

This fine document...

Was brought to you by me:



[Liberated Manuals -- free army and government manuals](#)

Why do I do it? I am tired of sleazy CD-ROM sellers, who take publicly available information, slap “watermarks” and other junk on it, and sell it. Those masters of search engine manipulation make sure that their sites that sell free information, come up first in search engines. They did not create it... They did not even scan it... Why should they get your money? Why are not letting you give those free manuals to your friends?

I am setting this document FREE. This document was made by the US Government and is NOT protected by Copyright. Feel free to share, republish, sell and so on.

I am not asking you for donations, fees or handouts. If you can, please provide a link to [liberatedmanuals.com](http://www.liberatedmanuals.com), so that free manuals come up first in search engines:

<A HREF=<http://www.liberatedmanuals.com/>>Free Military and Government Manuals

- Sincerely
Igor Chudov
<http://igor.chudov.com/>
- [Chicago Machinery Movers](#)