

Safety Regulation Group

CAP 482

British Civil Airworthiness Requirements

Section S - Small Light Aeroplanes

Safety Regulation Group

CAP 482

British Civil Airworthiness Requirements

Section S - Small Light Aeroplanes

Issue 6

Safety Regulation Group

CAP 482

British Civil Airworthiness Requirements

Section S - Small Light Aeroplanes

Issue 6

© Civil Aviation Authority 2013

All rights reserved. Copies of this publication may be reproduced for personal use, or for use within a company or organisation, but may not otherwise be reproduced for publication.

To use or reference CAA publications for any other purpose, for example within training material for students, please contact the CAA at the address below for formal agreement.

ISBN 978 0 11792 832 9

First Issue March 1983 (Advanced Issue)

Issue 1, 4 April 1995

Issue 2, 31 August 1999

Issue 3, 15 August 2003 (No technical changes, document has been restructured)

Issue 4, 21 December 2007

Issue 4, corrected, 31 January 2008

Issue 5, 21 October 2009

Issue 6, 31 May 2013

Enquiries regarding the content of this publication should be addressed to:
Airworthiness, Strategy and Policy Department, Safety Regulation Group, Civil Aviation Authority,
Aviation House, Gatwick Airport South, West Sussex, RH6 0YR.

The latest version of this document is available in electronic format at www.caa.co.uk, where you may also register for e-mail notification of amendments.

Published by TSO (The Stationery Office) on behalf of the UK Civil Aviation Authority.

Printed copy available from:

TSO, PO Box 29, Norwich NR3 1GN
Telephone orders/General enquiries: 0844 477 7300
Fax orders: 0870 600 5533

www.tsoshop.co.uk
E-mail: caa@tso.co.uk
Textphone: 0870 240 3701

List of Effective Pages

Part	Chapter	Page	Date	Part	Chapter	Page	Date
		iii	Revised 31 May 2013				
Contents		1	Revised 31 May 2013	Part 1	Sub-Section F	1	Revised 21 October 2009
Contents		2	Revised 31 May 2013	Part 1	Sub-Section F	2	Reissued 21 October 2009
Contents		3	Reissued 31 May 2013	Part 1	Sub-Section F	3	Reissued 21 October 2009
Foreword		1	Revised 21 December 2007	Part 1	Sub-Section G	1	Revised 31 May 2013
Foreword		2	Revised 21 December 2007	Part 1	Sub-Section G	2	4 April 1995
Preambles		1	Revised 31 January 2008	Part 1	Sub-Section G	3	Revised 21 October 2009
Preambles		2	Revised 31 May 2013	Part 1	Sub-Section G	4	Revised 21 October 2009
Abbreviations and Definitions	1		Revised 31 May 2013	Part 1	Sub-Section G	5	Revised 21 October 2009
Abbreviations and Definitions	2		Reissued 31 May 2013	Part 1	Sub-Section G	6	Reissued 21 October 2009
Part 1	Sub-Section A	1	Revised 21 October 2009	Part 1	Sub-Section J	1	Revised 21 October 2009
Part 1	Sub-Section B	1	Revised 31 August 1999	Part 1	Sub-Section J	2	Revised 21 October 2009
Part 1	Sub-Section B	2	Revised 31 August 1999	Part 1	Sub-Section K	1	Revised 31 August 1999
Part 1	Sub-Section B	3	Revised 21 December 2007	Part 1	Sub-Section K	2	Revised 31 May 2013
Part 1	Sub-Section B	4	Revised 21 December 2007	Part 1	Sub-Section K	3	31 May 2013
Part 1	Sub-Section B	5	Revised 21 December 2007	Part 1	Supplement	1	Revised 31 August 1999
Part 1	Sub-Section B	6	Revised 21 December 2007	Part 1	Supplement	2	Revised 31 August 1999
Part 1	Sub-Section B	7	Revised 21 December 2007	Part 1	Supplement	3	Revised 31 August 1999
Part 1	Sub-Section B	8	Revised 21 December 2007	Part 1	Supplement	4	Revised 31 August 1999
Part 1	Sub-Section C	1	Revised 21 October 2009	Part 2	Sub-Section B	1	Revised 31 August 1999
Part 1	Sub-Section C	2	Revised 21 December 2007	Part 2	Sub-Section B	2	Revised 21 December 2007
Part 1	Sub-Section C	3	Revised 21 October 2009	Part 2	Sub-Section C	1	Revised 21 October 2009
Part 1	Sub-Section C	4	Revised 21 October 2009	Part 2	Sub-Section C	2	Revised 21 October 2009
Part 1	Sub-Section C	5	Revised 21 October 2009	Part 2	Sub-Section C	3	Revised 21 October 2009
Part 1	Sub-Section C	6	Revised 21 December 2007	Part 2	Sub-Section C	4	Reissued 21 October 2009
Part 1	Sub-Section C	7	Reissued 21 December 2007	Part 2	Sub-Section C	5	Revised 21 December 2007
Part 1	Sub-Section C	8	Revised 21 December 2007	Part 2	Sub-Section D	1	Revised 31 May 2013
Part 1	Sub-Section C	9	Revised 21 December 2007	Part 2	Sub-Section D	2	Reissued 31 May 2013
Part 1	Sub-Section C	10	Revised 21 October 2009	Part 2	Sub-Section E	1	Revised 21 October 2009
Part 1	Sub-Section C	11	Revised 21 October 2009	Part 2	Sub-Section E	2	Reissued 21 October 2009
Part 1	Sub-Section D	1	Revised 31 May 2013	Part 2	Sub-Section F	1	Revised 21 October 2009
Part 1	Sub-Section D	2	Revised 21 December 2007	Part 2	Sub-Section F	2	Reissued 21 October 2009
Part 1	Sub-Section D	3	Revised 21 December 2007	Part 2	Sub-Section G	1	Revised 21 October 2009
Part 1	Sub-Section D	4	Revised 21 October 2009	Part 2	Sub-Section J	1	21 December 2007
Part 1	Sub-Section D	5	4 April 1995	Part 2	Sub-Section K	1	Revised 31 August 1999
Part 1	Sub-Section D	6	4 April 1995	Part 2	Sub-Section K	2	Revised 31 August 1999
Part 1	Sub-Section D	7	Revised 21 December 2007	Part 2	Supplement	1	Revised 31 August 1999
Part 1	Sub-Section D	8	Revised 21 October 2009				
Part 1	Sub-Section D	9	Reissued 21 October 2009				
Part 1	Sub-Section E	1	Revised 21 December 2007				
Part 1	Sub-Section E	2	Revised 21 October 2009				
Part 1	Sub-Section E	3	Revised 21 December 2007				
Part 1	Sub-Section E	4	Revised 31 May 2013				
Part 1	Sub-Section E	5	Reissued 21 December 2007				
Part 1	Sub-Section E	6	Revised 21 October 2009				
Part 1	Sub-Section E	7	Reissued 21 October 2009				

INTENTIONALLY LEFT BLANK

Contents

List of Effective Pages	iii
Foreword	1
Preambles	1
Section S	1
Abbreviations and Definitions	2
Part 1 Requirements	
Sub-Section A General	
Sub-Section B Flight	
General	1
Performance	2
Controllability and Manoeuvrability	3
Stability	5
Stalls	6
Spinning	7
Ground Handling Characteristics	8
Miscellaneous Flight Requirements	8
Sub-Section C Structure	
General	1
Flight Loads	2
Control Surfaces and Systems	5
Horizontal Stabilising Surfaces	7
Vertical Stabilising Surfaces	7
Supplementary Conditions for Stabilising Surfaces	7
Ailerons	8
Ground Loads	8
Emergency Landing Conditions	11
Other Loads	11

Sub-Section D Design and Construction

General	1
Control Surfaces	4
Control Systems	4
Landing Gear	6
Cockpit Design	7

Sub-Section E Powerplant

General	1
Fuel System	2
Oil System	4
Cooling	5
Induction System	5
Exhaust System	5
Powerplant Controls and Accessories	6

Sub-Section F Equipment

General	1
Instruments: Installation	2
Electrical Systems and Equipment	2
Miscellaneous Equipment	3

Sub-Section G Operating Limitations

General	1
Markings and Placards	2
Pilot's Handbook	4

Sub-Section J Propellers

Design and Construction	1
-------------------------	---

Sub-Section K Microlight Parachute Recovery Systems

Supplement Requirements for Microlight Aeroplanes to be used for Aerotowing of Hang Gliders

Sub-Section A General	1
Sub-Section B Flight	1
Sub-Section C Structure	2
Sub-Section D Design and Construction	2

Sub-Section E Powerplant	3
Sub-Section G Operating Limitations and Information.	3

Part 2 Acceptable Means of Compliance and Interpretative Material (AMC)

Sub-Section B	Flight
Sub-Section C	Structure
Sub-Section D	Design and Construction
Sub-Section E	Powerplant
Sub-Section F	Equipment
Sub-Section G	Operating Limitations
Sub-Section J	Propellers
Sub-Section K	Microlight Parachute Recovery Systems
Supplement	Requirements for Microlight Aeroplanes to be used for Aerotowing of Hang Gliders

INTENTIONALLY LEFT BLANK

Foreword

1 General

[This BCAR Section S (CAP 482) is published in support of the powers of the Civil Aviation Authority contained in Article 9 of the Air Navigation Order 2005 as amended.]

- 1.1 This BCAR Section S contains requirements for Small Light Aeroplanes which have been developed by considerably simplifying the existing requirements for Sailplanes and Powered Sailplanes from JAR-22.
- 1.2 Aeroplanes which have been shown to comply with BCAR Section S will only be eligible for a Permit to Fly.
- 1.3 The level of airworthiness implied by these requirements is not appropriate to the use of microlight aeroplanes for the purpose of public transport or aerial work (other than aerial work consisting solely of the giving of instruction in flying), nor is it appropriate to the issue of UK Certificates of Airworthiness.

2 Recognition

Recognition will be accorded to small light aeroplanes designed, manufactured and tested in accordance with technical standards or regulations of other [] states [], which ensure an equivalent level of safety. The results of checks and tests carried out by suitably qualified and approved bodies and laboratories of other [] states [] will be taken into consideration where such results provide a level of accuracy, fitness and suitability for purpose equivalent to the results of tests carried out in the United Kingdom and where such bodies and laboratories offer a suitable and satisfactory guarantee of technical and professional competence and understanding.

3 Interpretation

- 3.1 These requirements, with or without explanatory material, should not be regarded as constituting a textbook of current aeronautical knowledge; interpretation of the requirements against a background of such knowledge is essential.
- 3.2 Where necessary, the mandatory requirements have been supplemented by [interpretative material], which give acceptable interpretation of requirements, state recommended practices or give supplementary information.
- 3.3 Mandatory clauses are invariably denoted by the use of 'shall' or 'must', 'should' or 'may' are used in the text to indicate permissive or recommended clauses.
- 3.4 It is implicit in requirements expressed qualitatively (e.g. 'readily visible', 'adequately tested') that the CAA will adjudicate in cases where doubt exists.

[]

4 Presentation

4.1 Arrangement of Requirements

This BCAR Section S is divided into 2 Parts []. Part 1 is further divided into 11 sub-sections and Part 2 is Acceptable Means of Compliance (AMC). Where there is AMC material that relates to the whole paragraph, reference to it will appear after the main paragraph title. If there is AMC material that only relates to a certain sub-paragraph(s) reference to it will appear after the affected paragraph(s).

4.2 Editorial

As far as possible, BCAR Section S paragraphs carry the same number as the equivalent paragraph in FAR/[CS-23].

4.3 S.I. units

S.I. units have been used in these requirements.

NOTE: Strict observance of the S.I. system is not compatible with current aeronautical practice, in which performance data are scheduled. Consequently, some variations from S.I. units will be found in Sub-Section B.

5 Amendment and Issue

5.1 The printed version of the Section, which is identified by an Issue No. and date will be deemed to be amended by each BCAR Amendment, appropriate to the Section, which is issued subsequent to the date of issue of the printed version.

[]

5.2 Material differences from the previous issue of each page are indicated with [bold square brackets].

5.3 The issue or revision date is indicated at the foot of each page. The significance of the wording is as follows:

[a) (Date) – Date of first issue of that page.]

b) Revised (Date) – Revisions, indicated by bold square brackets, have been introduced at the revision date.

c) Reissued (Date) – The text on the page has not changed from the previous issue or amendment, but the page has been reissued because of movement of text on the page [].

6 Effective Date

New requirements and amendments promulgated in BCAR Amendments are effective from the date printed on them. Thus for any application made on or after the date of issue of a printed version of the Section, the effective requirements will be made up of those in the printed version of the Section together with those in any appropriate BCAR Amendments incorporated at the time the application is made.

7 Application and Enquiries

[] For further copies of this Section [please contact TSO (see reverse of Title page for details)]. Applications for permission to reproduce any part of the requirements and any enquiries regarding their technical content should be addressed to the Civil Aviation Authority, Safety Regulation Group, Aviation House, Gatwick Airport South, West Sussex RH6 0YR.

Preambles

Section S

4 April 1995

BCAR Section S is the basis for the issue of Permits to Fly for new types of small light aeroplanes, application for approval of which is received after the above date. The basis for the issue of Certificates of Airworthiness for small light aeroplanes will continue to be JAR-VLA.

Issue 1 of BCAR Section S presents the technical intent of the advance issue, which was published in March 1983. In addition, Working Draft Papers S854, S856, S857, S861, S863 and S867 have been consolidated into the text, together with some additional material which has been taken from Working Draft Papers S855, S865 and S866.

BCAR Section S Issue 1 is made effective upon acceptance of the advice of the Airworthiness Requirements Board.

Issue 2

31 August 1999

Issue 2 consolidates Working Draft Papers S848, S880, S885, S887, S896 and S901 into the text.

These regulations were notified in draft to the European Commission in accordance with Directive 98/34/EC (formerly 83/189/EEC 19834 O.J. L109/8), (as amended).

Issue 3

15 August 2003

Issue 3 contains **no new technical changes** from those incorporated in Issue 2. The publication has however been restructured to mirror the layout of Joint Aviation Requirements (JAR) codes and European Aviation Safety Agency (EASA) Certification Specifications. Marginal lines have been replaced with bold square brackets. The AMC material has been moved to a separate section and references to any AMC material inserted against the relevant paragraph/s. The pages have been re-dated to show the applicability date of any technical material contained in them.

Issue 4

21 December 2007

Issue 4 consolidates Working Draft Papers S930 and S934 into the text.

These regulations were notified in draft to the European Commission in accordance with Directive 98/34/EC (formerly 83/189/EEC 19834 O.J. L109/8, as amended).

Issue 4 corrected

31 January 2008

A correction to the occupant weight published in Issue 4, AMC S785 a) was made.

Issue 5

21 October 2009

Issue 5 incorporates Working Draft Paper S 937 into the text.

These regulations were notified in draft to the European Commission in accordance with Directive 98/34/EC (formerly 83/189/EEC 19834 O.J. L109/8, as amended).

[Issue 6

31 May 2013

Issue 6 of BCAR S, dated 31 May 2013 incorporates Working Draft Papers S 963, S 965 and S 966 into the text.

Paper S 963 introduces changes to BCAR Section S following an accident to a foreign registered aircraft. AAIB analysis of the aircraft, its installed equipment and potential hazards led to a recommendation to agree a common standard warning placard for ballistic recovery parachutes.

Papers S 965 and S 966 introduce changes applicable to BCAR Section S, that followed the review of Paper T 957 incorporated into BCAR Section T at issue 4, dated 29 July 2011.

Some editorial changes convenient to be made at this time, have also been incorporated.]

Abbreviations and Definitions

Abbreviations

C_{m0} The zero lift pitching moment coefficient.

[EAS Equivalent airspeed. True airspeed $\times \left(\frac{\rho}{\rho_0} \right)^{1/2}$ where ρ is the air density and ρ_0 is the air density in standard sea level conditions.

IAS Indicated airspeed. The readings of the pitot-static airspeed indicator as installed in the aeroplane, corrected only for instrument error.]

V_A The Design Manoeuvre Speed, EAS.

V_C The Design Cruising Speed, EAS.

V_D The Design Diving Speed, EAS.

V_{DF} The maximum speed attainable up to V_D that can be demonstrated in flight.

V_F The Design Flaps-Extended Speed, EAS.

V_{FE} The Wing Flaps Extended Speed. A maximum speed IAS with wing flaps in a prescribed extended position.

V_H The maximum level speed at maximum continuous power.

V_{LO} The Landing Gear Operating Speed. A maximum speed IAS at which it is safe to extend or retract the landing gear.

V_{NE} The Never Exceed Speed.

V_{S1} A stalling speed (or if no stalling speed is obtainable, a minimum steady flight speed), EAS, with the aeroplane in the configuration appropriate to the case under consideration.

V_{S0} A stalling speed (or if no stalling speed is obtainable, a minimum steady flight speed), EAS, with the wing flaps in the landing setting.

Definitions

Fireproof

'Fireproof' with respect to materials, components and equipment means the capability to withstand the application of heat by a flame, for a period of 15 minutes without any failure that would create a hazard to the aircraft.

Compliance with the criteria for fireproof materials or components should be shown as follows:

- 1) The flame to which the materials or components are subjected should be $1100^{\circ}\text{C} \pm 80^{\circ}\text{C}$.
- 2) Sheet materials approximately 64 cm^2 should be subjected to the flame from a suitable burner.

3) The flame must be large enough to maintain the required test temperature over an area approximately 13 mm².

For example, materials which are considered fireproof without being subjected to fire tests include:

- a) stainless steel sheet 0.4 mm (0.016 in) thick;
- b) mild steel sheet protected against corrosion 0.45 mm (0.018 in) thick; and
- c) titanium sheet 0.45 mm (0.018 in) thick.

Fire-resistant

'Fire-resistant' with respect to materials, components and equipment means the capability to withstand the application of heat by a flame, as defined for 'Fireproof', for a period of 5 minutes without any failure that would create a hazard to the aircraft.

For materials this may be considered to be equivalent to the capability of withstanding a fire at least as well as aluminium alloy, in dimensions appropriate for the purposes for which they are used.

Part 1 Requirements

Sub-Section A General

S 2 Applicability

- a) This Section S states requirements applicable to aeroplanes:
- 1) having a maximum total weight authorised (MTWA) not exceeding 300 kg for single seat aeroplanes [(315 kg if fitted with an airframe mounted emergency parachute recovery system)], or 450 kg for two seat aeroplanes [(472.5 kg if fitted with an airframe mounted emergency parachute recovery system)];
 - 2) designed to carry not more than two persons; and
 - 3) with either:
 - i) a wing loading at the MTWA not exceeding 25 kg per square metre; or
 - ii) a stalling speed V_{S0} , of not greater than 65 kph (35 kt) CAS for wing loadings greater than 25 kg/square metre.

For the purpose of UK airworthiness requirements such aeroplanes are referred to as 'microlight' aeroplanes. The requirements are applicable to all microlight aeroplanes whether they have 'rigid' or 'flexible' flying surfaces and whether their means of flight control is by conventional control surfaces or any other means.

- b) Where the requirements of Section S are inappropriate to particular design and construction features it will be necessary to reconsider the validity of the requirements for each particular case, and the CAA must be consulted as to the applicable requirements.
- c) Permitted Operations
- A microlight aeroplane granted a Permit to Fly will be permitted only non-aerobatic operation. Non-aerobatic operation is intended to include:
- 1) Any manoeuvre necessary for normal flying.
 - 2) Stalls.
 - 3) Steep turns in which the angle of bank does not exceed 60°.
- d) In the absence of any indication to the contrary, requirements and recommendations are applicable to all aeroplanes.
- e) The method of indicating that a requirement is applicable only to aeroplanes of a specific weight range, to special conditions of certification or to aeroplanes having specified technical features, is an appropriate reference in the paragraph title or text.

INTENTIONALLY LEFT BLANK

Sub-Section B Flight

General

S 21 **Proof of compliance** (See AMC S 21).

- a) Each requirement of this Sub-Section must be met by test upon an aeroplane of the type for which a Permit to Fly is requested at the most adverse combination of weight and centre of gravity (c.g.) within the range of loading conditions for which certification is requested. If control is effected by weight shift, it must be shown that the handling qualities meet the requirements at the maximum and minimum weights established under S 23. (See AMC S 21 a.)
- b) Compliance must be established for all configurations at which the aeroplane will be operated except as otherwise stated.

NOTE: Flight tests required in this Sub-Section B do not constitute all the flight testing necessary to show compliance.

S 23 **Load distribution limits**

- a) The ranges of weight and c.g. within which the aeroplane is to be safely operated must be selected by the applicant.
- b) The c.g. range must not be less than that which corresponds to the weight of each occupant, varying between a minimum of 55 kg for the pilot alone up to the maximum placarded weight with a pilot and passenger, together with a variation in fuel contents from zero to full fuel. The placarded maximum [occupant] weight must be not less than [86 kg] per person. (See AMC S 23 b.)

S 25 **Weight limits**

Maximum weight. The maximum weight must be established so that it is:

- a) not more than:
 - 1) the highest weight selected by the applicant;
 - 2) the design maximum weight, which is the highest weight at which compliance with each applicable structural loading condition and each applicable flight requirement is shown.
- b) not less than the weight which results from the empty weight of the aeroplane, plus a weight of occupant(s) of [86] kg for a single-seat aeroplane, or [172] kg for a two-seat aeroplane, plus the required minimum equipment, plus [] fuel [for at least 60 minutes flight at maximum continuous power.]
[]
- c) [not less than the weight which results with one (86 kg pilot) occupant, required minimum equipment and maximum fuel. (See AMC S 25 c).]

S 29 **Empty weight and corresponding c.g.**

- a) The empty weight and corresponding c.g. must be determined by weighing each aeroplane:
 - 1) with:
 - i) fixed ballast;
 - ii) required minimum equipment;

- iii) unusable fuel, maximum oil and, where appropriate, engine coolant and hydraulic fluid;
- 2) excluding the weight of the occupant(s).
- b) The condition of the aeroplane at the time of determining empty weight must be one that is well defined and easily repeated, [and must be specified in the weighing report which demonstrates compliance with these requirements.]

Performance

S 45 General

Compliance with performance requirements of this Sub-Section must be shown at maximum weight for still-air in standard atmosphere at sea-level conditions using engine power not in excess of the maximum declared for the engine type.

S 49 Stalling speed

- a) V_{S0} is the stalling speed (CAS), if obtainable, or the minimum steady speed at which the aeroplane is controllable, with the engine idling (throttle closed) or engine off, whichever gives the higher value of V_{S0} , and:
 - 1) the aeroplane in the landing configuration; and
 - 2) maximum weight.
- b) V_{S1} is the stalling speed (CAS), if obtainable, or the minimum steady speed at which the aeroplane is controllable with the engine idling (throttle closed), or engine off, and:
 - 1) in the configuration existing in the test in which V_{S1} is being used; and
 - 2) at maximum weight.
- c) V_{S0} and V_{S1} must be determined by flight tests using the procedure specified in S 201.

S 51 Take-off

The take-off distance at maximum weight and in zero wind, from rest to attaining a height of 15 metres at a speed not less than $1.3 V_{S1}$ or $V_{S1} + 10$ knots, whichever is the greater, must be determined when taking off from a dry, level, short-grass surface. (See AMC S 51).

S 65 Climb

The time for climb from leaving the ground up to 1000 ft above the field must be determined and, when corrected at sea level, must not exceed four minutes with:

- a) not more than take-off power;
- b) landing gear retracted;

and without exceeding any temperature limits established under S 1041.

S 71 Rate of descent

The rate of descent in power-off en-route configuration at maximum weight must be determined.

S 75 Landing

The landing distance on a dry level short-grass surface at maximum weight and in zero wind from a height of 15 metres must be determined. The speed at 15 metres should

be the recommended approach speed, but not less than 1.3 V_{S0} or $V_{S0} + 10$ knots, whichever is the greater, at a power setting to be stated in the Pilot's Handbook.

Controllability and Manoeuvrability

S 143 General

- a) The aeroplane must be safely controllable and manoeuvrable during;
 - 1) take-off at maximum take-off power;
 - 2) [any steady] climb [condition];
 - 3) level flight;
 - 4) descent;
 - 5) landing, power on and off; and
 - 6) with sudden engine failure.
- b) It must be possible to make a smooth transition from one flight condition to another (including turns, reversal of turns and slips) with no more than average piloting skill, alertness or strength, and without danger of exceeding the limit load factor, under any probable operating condition, with the engine running at all allowable power settings, including the effect of power changes and sudden engine failure. Modest departures from any recommended techniques must not cause unsafe flight conditions. (See AMC S 143 b.)
- c) Any unusual flying characteristics observed during the flight tests required to determine compliance with the flight requirements and any significant variations in flight characteristics caused by rain must be determined with the engine running at all allowable powers.
- d) If marginal conditions exist with regard to pilot effort the 'pilot effort' limits must be shown by quantitative tests [for a minimum weight pilot]. In no case may the limits exceed those prescribed in the following table []. This requirement must be met with the engine running at all allowable powers. (See AMC S 143 d.)

[

For 3-axis control systems		Pitch daN	Roll daN	Yaw daN	Wing-flaps, air-brakes, landing gear – daN
a) Temporary application					
	Joystick	20	10	-	20
	Wheel (applied to rim)	25	20	-	
	Rudder pedal	-	-	40	
b) Prolonged application		2	1.5	10	
For weight-shift control systems		Pitch daN	Roll daN	Yaw daN	Wing-flaps, air-brakes, landing gear – daN
a) Temporary application					
	Control frame (using both arms)	25	20	-	20
	Foot steering pedal	-	-	40	
b) Prolonged application		2	1.5	10	

]

S 145 **Longitudinal Control**

- a) It must be possible at any speed below $1.3 V_{S1}$ to pitch the nose downwards so that a speed equal to $1.3 V_{S1}$ can be reached promptly.
 - 1) **Test conditions.** All possible configurations and engine powers when trimmed at $1.3 V_{S1}$ (where trim control is fitted).
- b) It must be possible throughout the appropriate flight envelope to change the configuration (landing gear, wing flaps etc.) without exceptional piloting skill and without exceeding the control forces defined in S 143 d).
- c) It must be possible to raise the nose at V_{DF} at all permitted c.g. positions and engine powers.
- [d) For weight-shift pitch control systems, it must be demonstrated that the wing generates a positive (nose-up) aerodynamic pitching moment at wing incidences over the range from +10 to -10 degrees about the zero lift angle of incidence, at a speed of V_{S0} . (See AMC S 145 d).]

S 147 **Lateral and directional control**

- a) Using an appropriate combination of controls, it must be possible to roll the aeroplane from a steady 30° banked turn through an angle of 60° , so as to reverse the direction of the turn within 5 seconds when the turns are made at speeds of $1.3 V_{S1}$ and at V_{NE} .
- b) (Applicable only if control is effected by weight shift). When a steady 60° banked turn is reversed by using maximum roll control at a speed between $1.6 V_{S1}$ and V_A , it must not be necessary to apply anti-roll control before reaching wings-level in order to avoid exceeding 60° of bank in the reversed direction.
- c) The tests required by a) and b) must be performed:
 - 1) where applicable, with the landing gear and wing-flaps retracted and with the landing gear and wing-flaps extended;
 - 2) without encountering uncontrollable rolling tendencies or uncommanded high roll rates; and
 - 3) with any uncommanded pitching during the manoeuvre being readily controllable.

S 155 **Pitch control force in manoeuvres**

The pitch control force during turns or when recovering from manoeuvres must be such that at a constant speed an increase in load factor is associated with an increase in control force. In addition:

- a) For conventional control systems the minimum value of this force to apply to the aeroplane a normal acceleration which would impose [limit] load on the structure must not be less than 7 daN [from a trimmed 1 g condition] at all speeds [up to V_{NE}] at which the required normal acceleration can be achieved without stalling, with wing-flaps and, where applicable, landing gear retracted.
- b) For weight shift/flexwing control aeroplanes:
 - 1) The control force to achieve proof load must be agreed with the CAA;
 - 2) There must be no sudden change of the pitch control force at achievable load factors within the limits established under S 337 at any speed [between V_{S1} and] V_{NE} ;

- 3) The static longitudinal stability requirements of S 173 a) must also be met under the conditions of b) 2) above.

S 161 **Trim**

The speeds to achieve lateral, longitudinal and directional trim must lie within $1.3 V_{S1}$ and $2.0 V_{S1}$ at all engine powers and the extreme c.g. positions.

Stability

S 171 **General**

The aeroplane must meet the conditions of S 173 to S 181 inclusive. In addition the aeroplane must show suitable stability and control 'feel' in any condition normally encountered in service.

S 173 **Static longitudinal stability**

- a) Under the conditions and throughout the speed range specified in S 175 the slope of the curve, control force versus speed, must be positive and have a value such that any significant speed change will cause a variation in control force plainly perceptible to the pilot.
- b) 1) Where the aeroplane can be trimmed longitudinally the airspeed must return to within 10% of the original trim speed when the aeroplane is disturbed from the trimmed condition.
- 2) Where the aeroplane has no longitudinal trimmer the airspeed must return to within 10% of the trim speed required by S 161 in each configuration, when the aeroplane is disturbed from the trimmed condition.

S 175 **Demonstration of static longitudinal stability**

The control force/speed curve must have a stable slope in the following conditions:

- a) Climb:
 - 1) At $1.4 V_{S1}$;
 - 2) Landing gear retracted;
 - 3) Wing-flaps in the position for climb; and
 - 4) Maximum power.
- b) Cruise:
 - 1) At maximum level flight speed and $[V_{DF}]$;
 - 2) Landing gear retracted;
 - 3) Wing-flaps retracted.
- c) Approach:
 - 1) At the recommended approach speed;
 - 2) Wing-flaps in the landing position;
 - 3) Landing gear extended; and
 - 4) Engine at normal approach power and with engine off.

S 177 Lateral and directional stability

- a) With the aeroplane in straight steady flight, and when the roll and yaw controls are gradually applied in opposite directions, any increase in sideslip angle must correspond to an increased deflection of the lateral control. This behaviour need not follow a linear law.
- b) In a sideslip any control force must increase progressively with sideslip; it need not be linear but must not reverse.

S 181 Dynamic stability

- a) Any short period oscillations not including combined lateral-directional oscillations occurring between the stalling speed and V_{DF} must be heavily damped with the primary controls:
 - 1) Free;
 - 2) Fixed.
- b) Any combined lateral-directional oscillations occurring between the stalling speed and V_{DF} must be damped with the primary controls:
 - 1) Free;
 - 2) Fixed.
- [c) Any long period oscillation of the flight path (phugoid) must not be so unstable as to cause an unacceptable increase in pilot workload or otherwise endanger the aeroplane. When, in the conditions of S 175, the longitudinal control force required to maintain speeds differing from the trimmed speed by at least $\pm 15\%$ is suddenly released, the response of the aeroplane must not exhibit any dangerous characteristics nor be excessive in relation to the magnitude of the control force released. (See AMC S 181 c).)]

These requirements must be met with the engine running at all allowable powers.

Stalls

S 201 Wings level stall

Stalling behaviour must be investigated at forward and aft c.g. limits and at the maximum and minimum weights established under S 23.

- a) Stall demonstrations must be conducted by reducing the speed by approximately 1 kt per second from straight and level flight until either a stall results as evidenced by a downward pitching motion or downward pitching and rolling motion not immediately controllable or until the longitudinal control reaches the stop. It must be possible to produce and correct roll and yaw by unreversed use of the controls until the stall occurs.
- b) It must be possible to prevent more than 20° of roll by normal use of the controls during recovery. There must be no tendency to spin.
- c) The loss of altitude from the beginning of the stall until regaining level flight by applying normal procedures and the maximum pitch attitude below the horizon must be determined. (See AMC S 201 c).)
- d) Compliance with the requirements of sub-paragraphs a) to c) of this paragraph must be shown under the following conditions:
 - 1) Wing-flaps in any position;
 - 2) Landing gear retracted and extended;

- 3) Trimmed to $1.4 V_{S1}$ (if fitted with a trimmer);
- 4) Power [(See AMC S 201 d) 4)]:
 - i) Engine idling; and
 - ii) Maximum continuous power[, or, if the power-to-weight ratio at maximum continuous power results in extreme nose-up attitudes, demonstration may be carried out with the power not less than that required for level flight in the landing configuration at maximum landing weight and a speed of $1.4 V_{S0}$, except that the power may not be less than 75% maximum continuous power].

S 203 **Turning flight stalls**

- a) When stalled during a co-ordinated 30° banked turn, it must be possible to regain normal level flight without encountering uncontrollable rolling or spinning tendencies. (See AMC S 203 a.)
- b) The loss of altitude from beginning of the stall until regaining level flight by applying normal procedures must be determined. This requirement must be met with the engine running in the conditions prescribed in S 201(d)(4) and the wing-flaps in any position.

S 207 **Recovery from the stall**

- a) An aeroplane which does not give warning of the approach of the stall may be acceptable provided that when a stall occurs from straight flight:
 - 1) it is possible to produce and correct roll by using the roll control, the yaw control being held neutral; and
 - 2) no appreciable wing-dropping occurs when both the roll and yaw controls are held neutral.
- b) An aeroplane which does not meet the conditions of a) must give clear and distinctive stall warning with the wing-flaps and landing gear in any normal position, both in straight and turning flight. The stall warning must not occur at normal operating speeds, but must occur sufficiently before the stall to allow the pilot to recover safely. The stall warning may be furnished either through the inherent aerodynamic qualities (e.g. buffeting) or by a device that will give clearly distinguishable indications.
- c) Aeroplanes with flexible lifting surfaces shall be designed to ensure that:
 - 1) if the surface deforms owing to a gust or any manoeuvre, the surface shall re-establish its profile quickly so as not significantly to delay recovery to normal level flight.
 - 2) application of full sustained control deflection(s), will not cause any control difficulties or, in the case of powered parachutes, cause canopy collapse.

Spinning

S 221 **General**

For any aeroplane that is not controlled by weight shift:

- a) the aeroplane must be able to recover from a one-turn erect spin or a 3 second erect spin, whichever takes longer, in not more than one additional turn, with the controls used in the manner normally used for recovery. The recovery must be demonstrated with flaps, airbrakes and undercarriage in any allowable position and

without exceeding the pilot effort limits for temporary application under S 143 and the applicable airspeed and positive manoeuvring load factor limitations.

b) it must be impossible to obtain unrecoverable spins with any use of the controls.

For the flaps and airbrakes extended condition, the flaps and airbrakes may be retracted during the recovery.

c) If clearance for intentional spinning is desired, the CAA must be consulted.

Ground Handling Characteristics

S 233 Directional stability and control

There must be no uncontrollable ground-loop tendency at any speed at which the aeroplane may be expected to be operated on the ground, and it must have adequate directional control during taxiing.

S 235 Take-off and landing in crosswinds

The ability to take-off and land safely in crosswinds shall be investigated. Based on the results of these tests, advice on operation in crosswinds shall be given in the Pilot's Handbook.

Miscellaneous Flight Requirements

S 251 Vibration and buffeting

Each part of the aeroplane must be free from excessive vibration at all speeds up to at least V_{DF} . In addition, there must be no buffeting, in any normal flight conditions, severe enough to interfere with the satisfactory control of the aeroplane, cause excessive fatigue to the crew, or result in structural damage. Stall warning buffeting within these limits is allowable. This requirement must be met with the engine running at all allowable powers [including start-up and shutdown].

Sub-Section C Structure

General

S 301 Loads

- a) Strength requirements are specified in terms of limit loads (the maximum loads to be expected in service) and ultimate loads (limit loads multiplied by prescribed factors of safety). Unless otherwise provided, prescribed loads are limit loads.
- b) Unless otherwise provided, the air and ground loads must be placed in equilibrium with inertia forces, considering each major item of mass in the aeroplane. These loads must be distributed so as to represent actual conditions or a conservative approximation to them.
- c) If deflections under load would significantly change the distribution of external or internal loads, this redistribution must be taken into account.
- d) The structural integrity criteria in Sub-Sections C and D for flight conditions are applicable to aeroplanes with a design maximum speed V_D not exceeding 140 kt EAS. For aeroplanes with a design maximum speed in excess of this, then subparts C, D and paragraphs 1505, 1511, 1545 and 1583 a) of CS VLA may be used as the appropriate structural integrity criteria. The Authority must be consulted if an alternative code is to be used.

S 303 Factor of safety

- a) Unless otherwise provided, a factor of safety of 1.5 must be used.
- b) For the textile fabric elements of powered parachute wings, a factor of safety of at least 5 must be used. A reduced factor of safety of at least 2 may be used if it is shown that the stated factor will preclude failure due to creep and provide adequate protection against tear propagation.

S 305 Strength and deformation

- a) The structure must be able to support limit loads without [detrimental] permanent deformation. At any load up to limit loads, the deformation may not interfere with safe operation. This applies in particular to the control system.
- b) The structure must be able to support ultimate loads without failure for at least three seconds. However, when proof of strength is shown by dynamic tests simulating actual load conditions, the three second limit does not apply.

S 307 Proof of structure

- a) Compliance with the strength and deformation requirements of S 305 must be shown for each critical load condition. Theoretical structural analysis may be used only if the structure conforms to those for which experience has shown this method to be reliable. In other cases, substantiating load tests must be made. (See AMC S 307 a.)
- b) Certain parts of the structure must be tested as specified in Sub-Section D of these requirements.

NOTE: Structural requirements contained in Sub-Section C do not constitute all of the structural requirements necessary to show compliance

Flight Loads

S 321 **General [(see AMC S 321)]**

- a) Flight load factors represent the ratio of the aerodynamic force component (acting normal to the flight path of the aeroplane) to the weight of the aeroplane. A positive flight load factor is one in which the aerodynamic force acts upward, with respect to the aeroplane.
- b) Compliance with the flight load requirements must be shown:
 - 1) at each critical altitude within the range in which the aeroplane may be expected to operate; and
 - 2) at each practicable combination of weight and disposable load [within the operating limitations specified in the Flight Manual]. (See AMC S 321 b.)

S 331 **Symmetrical flight conditions**

- a) The appropriate balancing loads on horizontal stabilising surfaces must be accounted for in a rational or conservative manner when determining the wing loads and linear inertia loads corresponding to any of the symmetrical flight conditions specified in S 333 to S 345.
- b) The incremental loads on horizontal stabilising surfaces due to manoeuvring must be reacted by the angular inertia of the aeroplane in a rational or conservative manner.
- c) In computing the loads arising in the prescribed conditions, the angle of attack is assumed to be changed suddenly without loss of flight speed until the prescribed load factor is attained. Angular accelerations may be disregarded.
- d) Aerodynamic data required for the establishment of the loading conditions must be verified by tests, calculations or by conservative estimation.
 - 1) In the absence of better information the maximum negative lift coefficient for rigid lifting surfaces in the normal configuration may be taken as -0.8 . For flexible lifting surfaces the CAA must be consulted.
 - 2) If the [zero lift] pitching moment coefficient C_{m0} is less than ± 0.025 , a coefficient of at least ± 0.025 must be used for the wing and horizontal stabilising surfaces.
 - [3) At Condition A and Condition G of the flight envelope, in lieu of a lower value justified by rational analysis, a load equalling 25% of the lift force acting on the wing must be applied to the wing in the forward direction, parallel to the wing chord line in a suitable span-wise distribution (see AMC S 337 a) 1) and b) 1) for suitable distributions).]

S 333 **Flight envelope**

- a) **General.** Compliance with the strength requirements must be shown at any combination of air speed and load factor on and within the boundaries of the flight envelope specified by manoeuvring criteria of sub-paragraph b) of this paragraph.
- b) **Manoeuvring envelope.** Wing-flaps in the en-route setting (see Figure 1).

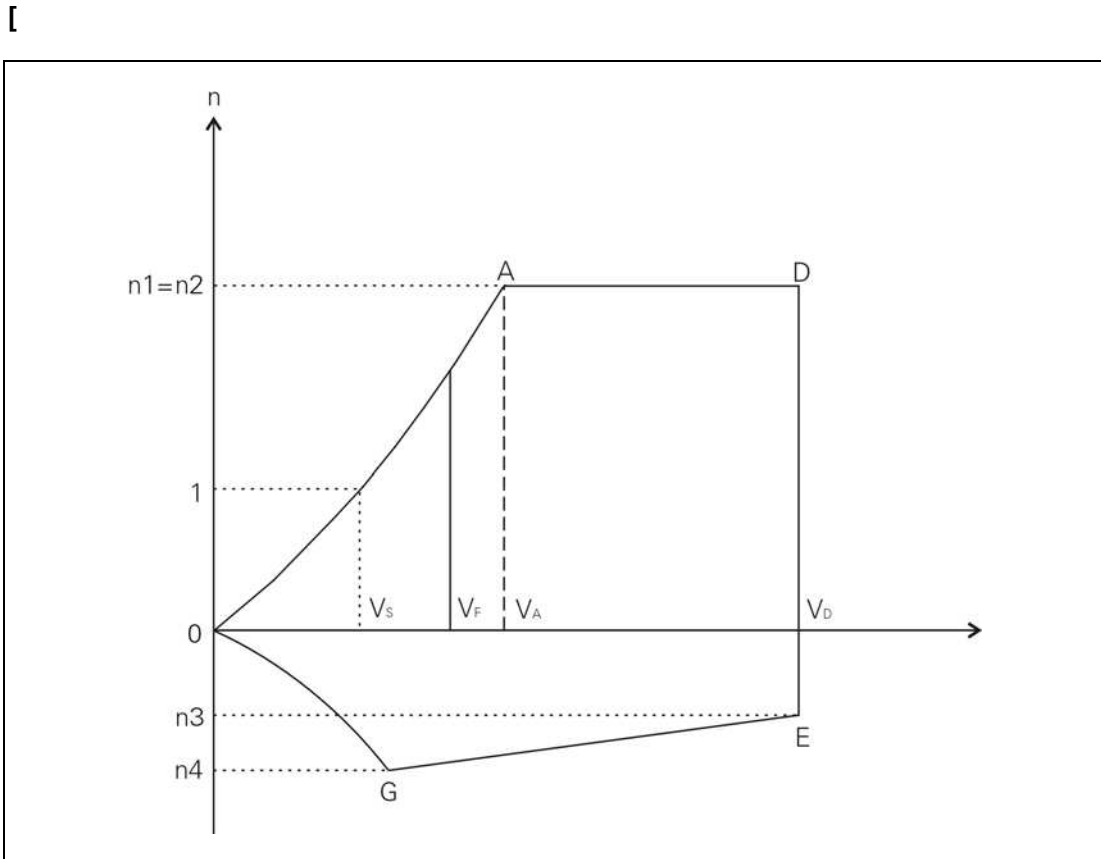

S 335 **Design air speeds**

The selected design air speeds are equivalent air speeds (EAS):

a) Design manoeuvring speed V_A

$$V_A = V_{S1} \sqrt{n1}$$

where:

V_{S1} = estimated stalling speed at design maximum weight with wing-flaps retracted and engine idling.

b) Design flap speed, V_F

1) For each landing setting, V_F must not be less than the greater of:

- i) $1.4 V_S$, where V_S is the computed stalling speed with wing-flaps retracted at the maximum weight;
- ii) $2.0 V_{SF}$, where V_{SF} is the computed stalling speed with wing-flaps fully extended at the maximum weight.

c) Design diving speed V_D . The design maximum speed may be chosen by the applicant but must not be lower than: $1.4 V_H$ where V_H is the maximum level speed at maximum continuous power.

S 337 Limit manoeuvring load factors (See AMC S 337).

The limit manoeuvring load factors on the V-n diagram (see Figure 1) must have at least the following values:

Category	Non-aerobatic
n 1	+4.0
n 2	+4.0
n 3	-1.5
n 4	-2.0

The negative manoeuvring load factors for flexible lifting surface aeroplanes which have limited ability to sustain negative accelerations in flight must be agreed with the CAA.

S 345 Loads with wing-flaps extended

If wing-flaps are installed, the aeroplane must be assumed to be subjected to manoeuvres up to a positive limit load factor of 4.0 with wing-flap positions from retracted to the maximum setting, at speeds up to V_F .

S 347 Unsymmetrical flight conditions (See AMC S 347).

The aeroplane is assumed to be subjected to the unsymmetrical flight conditions of S 349 and S 351. Unbalanced aerodynamic moments about the c.g. must be reacted in a rational or conservative manner, considering the principal masses furnishing the reacting inertia forces.

S 349 Rolling conditions (See AMC S 349)

The aeroplane must be designed for the rolling loads resulting from the roll control deflections and speeds specified in S 455 in combination with a load factor of at least two-thirds of the positive manoeuvring load factors prescribed in S 337.

S 351 Yawing conditions

The aeroplane must be designed for yawing loads on the vertical tail surface specified in S 441.

S 361 Engine torque

- a) The engine mount and its supporting structure must be designed for the effects of:
- 1) The limit torque corresponding to take-off power and propeller speed, acting simultaneously with 75% of the limit loads from flight condition A of S 333 b) [and including the effects of engine thrust where this is critical];
 - 2) The limit torque corresponding to the maximum continuous power and propeller speed, acting simultaneously with the limit loads from flight condition A of S 333 b) [and including the effects of engine thrust where this is critical].

- b) For conventional reciprocating engines with positive drive to the propeller, the limit torque to be accounted for in S 361 a) is obtained by multiplying the mean torque by the appropriate factor from the following tables:

cylinders	Two-stroke engine		
	1	2	3 or more
Factor	6	3	2

cylinders	Four-stroke engine				
	1	2	3	4	5 or more
Factor	8	4	3	2	1.33

NOTE: 'Positive drive' includes direct drive, gear drive or toothed belt; for other drives (e.g. centrifugal clutch) and unconventional engines the appropriate factor must be agreed with the CAA.

S 363 Side load on engine mount

- a) The engine mount and its supporting structure must be designed for a limit load factor in a lateral direction, for the side load on the engine mount, of not less than one-third of the limit load factor for flight condition A (1/3 n1).
- b) The side load prescribed in a) may be assumed to be independent of other flight conditions.

Control Surfaces and Systems

S 395 Control systems

- a) Each flight control system and its supporting structure and stops] must be designed for the loads corresponding to at least 125% of the [computed hinge moments of the moveable control surface in the conditions prescribed in S 421 to S 455. In addition the following apply:
- 1) The system limit loads need not exceed the loads that can be produced by the pilot. Pilot forces used for design need not exceed the forces prescribed in S 397 [a]).
 - 2) The design of the control system and its stops must, in any case, provide a rugged system for service use, considering jamming, ground gusts, taxiing down-wind, control inertia, and friction. Compliance with this sub-paragraph may be shown by designing for loads resulting from application of 60% of the pilot loads specified in S 397 [a]).
- b) For flexwing aircraft, control systems for the direct control of the aeroplane about its longitudinal, lateral or yaw axis (main control system) and supporting points must be designed to withstand, as far as to the stops (these included), limit loads arising from the pilot forces in S 397 [a]).
- c) Pilot forces used for design are assumed to act at the appropriate control grips or pads as they would in flight, and to react at the attachments of the control system to the control surface horns.

S 397 Loads resulting from limit pilot forces [(See AMC S 397)

a) In the control surface flight loading condition, the air loads on moveable surfaces and the corresponding deflections need not exceed those that would result in flight from the application of any pilot force within the ranges specified in subparagraph b) of this paragraph. In applying this criterion the effects of tabs, or other aerodynamic devices where they can affect control system loads, must be considered.]

For [] other unconventional control systems (e.g. side stick controls) lower pilot forces may be agreed by the CAA, provided [that] it can be demonstrated that the forces in the table cannot be applied.[]

Control	Pilot force daN	Method of application assuming single-lever control systems
Pitch Stick: Wheel:	75 90	Push and pull handgrip of control stick Push and pull control wheel
Roll Stick: Wheel:*	30 22.2D**	Move handgrip of control stick sideways Rotate control wheel
Yaw and other foot controls	90	Apply forward pressure on one rudder pedal

* The critical parts of the aileron control system must also be designed for a single tangential force with a limit value of 1.25 times the couple force determined from the above criteria.

** D = wheel diameter.]

b) The yaw control system must be designed to a load of 100 daN per pedal acting simultaneously on both pedals in a forward direction.

S 399 Dual control systems

Dual control systems must be designed to withstand the loads that result when each pilot applies 0.75 times the load specified in S 397 a), with:

- a) the pilots acting together in the same direction; and
- b) the pilots acting in opposition.

S 405 Secondary control systems (See AMC S 405).

Secondary control systems such as those for landing gear retraction or extension, trim control etc. must be designed for supporting the maximum forces that a pilot is likely to apply to those controls.

S 411 **Control system stiffness and stretch** (See AMC S 411).

- a) The amount of control surface or tab movement available to the pilot shall not in any condition be dangerously reduced by elastic stretch of the control circuits.

Control	Pilot force daN	Method of force application assuming single-lever control system
Pitch	40	Push and pull handgrip of control stick
Roll	20	Move handgrip of control stick sideways
Yaw	45	Apply forward pressure on one rudder pedal

- b) For cable-operated systems, the allowable rigging tension in the cables must be established, taking into consideration the variations in temperature (see S 689) which may occur.

Horizontal Stabilising Surfaces

S 421 **Balancing loads**

- a) A horizontal stabilising surface balancing load is the load necessary to maintain equilibrium in any specified flight condition with no pitching acceleration.
- b) The horizontal stabilising surface must be designed for the balancing loads occurring at any point of the limit manoeuvring envelope and in the wing-flap positions as specified in S 333 and S 345.

S 423 **Manoeuvring loads** (See AMC S 423).

The horizontal stabilising surface must be designed for the most severe loads likely to occur in pilot-induced pitching manoeuvres, at all speeds up to V_D .

S 427 **Unsymmetrical loads**

The slipstream effect on fixed surfaces and on rudder loads must be accounted for if such loading is to be expected.

Vertical Stabilising Surfaces

S 441 **Manoeuvring load**

The vertical stabilising surfaces must be designed for manoeuvring loads imposed by the following conditions:

- a) At speed V_A , full deflection of the yaw control;
- b) At speed V_D , one-third of full deflection of the yaw control.

Supplementary Conditions for Stabilising Surfaces

S 447 **Combined loads on stabilising surfaces** (See AMC S 447).

- a) With the aeroplane in a loading condition corresponding to point A or D in the V-n diagram (whichever condition leads to the higher balance load) the loads on the horizontal stabilising surfaces must be combined with those on the vertical stabilising surfaces specified in S 441. It must be assumed that 75% of the loads

according to S 423 (for the horizontal stabilising surfaces) and S 441 (for the vertical stabilising surfaces) are acting simultaneously.

- b) **Asymmetric loading.** The stabilising surfaces and fuselage must be designed for asymmetric loads on the stabilising surfaces which would result from application of the highest symmetric manoeuvre loads of S 423 so that 100% of the horizontal stabiliser surface loading (load per unit area) is applied to the horizontal stabilising surfaces on one side of the plane of symmetry and 70% on the opposite side.

Ailerons

S 455 Ailerons

The ailerons must be designed for control loads corresponding to the following conditions:

- a) At speed V_A the full deflection of the roll control; and
 b) At speed V_D , one-third of the full deflection of the roll control.

Ground Loads

S 471 General [(See AMC S 471)]

The limit ground loads specified in this Sub-Section are considered to be external loads and inertia forces that act upon an aeroplane structure. In each specified ground load condition, the external reactions must be placed in equilibrium by the linear and angular inertia forces in a rational or conservative manner.

S 473 Landing gear – shock absorption (See AMC S 473).

- a) It shall be determined that the landing gear is capable of absorbing the energy which would result from the aeroplane being dropped at its maximum permitted take-off weight from a height of h [(in metres),] where:

$$\left[h = 0.041 \left(\frac{W}{S} \right)^{\frac{1}{2}} \right]$$

W being the maximum permitted take-off weight (kg), S being the wing area (m^2) [and h being the distance between the impact surface and the most adjacent point of the tyre in the unloaded state]:

without either the shock absorber or the tyres bottoming.

- b) Compliance must be established for pitch attitudes representing:
- 1) the level attitude with the main and nose wheels (if appropriate) in contact with the ground;
 - 2) the level attitude with main wheels in contact with the ground and nose wheels (if appropriate) just clear of the ground;
 - 3) the tail-down attitude with the tail wheel or tail structure just clear of the ground.
- c) It shall be determined that the nose gear can absorb energy from the front equivalent to 100% of the energy that the nose gear is required to absorb vertically by S 473 b) 2).

S 474 **Landing case – strength [(See AMC S 474)]**

- a) The selected limit vertical inertia load factor for the airborne landing conditions at the centre of gravity of the aeroplane may not be less than that obtained when landing with a vertical velocity of $0.9 (W/S)^{1/4}$ m/s.
- b) Wing lift not exceeding two thirds of the weight of the aeroplane may be assumed to exist throughout the landing impact and to act through the centre of gravity. The landing gear reaction factor may be equal to the inertia load factor minus the ratio of the above assumed wing lift to the aeroplane weight.
- c) In the absence of load factors determined from drop testing, a limit vertical landing gear reaction factor of 3 must be used which may be based on static reactions for all the wheels in contact at touchdown. []
- d) The minimum [vertical landing gear reaction factor used for design may not be less than 2.0] at maximum weight.
- e) Tail wheels and skids must be weaker than the aeroplane structure to which they are attached.
- f) **Bicycle Undercarriages.** For undercarriage configurations consisting of centre-line wheels, the wheel nearer the aircraft c.g. must be treated as the Main Wheel. The other wheel must be treated as either a nose wheel or a tail wheel, as appropriate.

S 479 **Level landing conditions**

- a) For a level landing the aeroplane is assumed to be in the following flight attitudes:
 - 1) For aeroplanes with tail wheels, a normal level flight attitude;
 - 2) For aeroplanes with nose wheels, attitudes in which:
 - i) the nose and main wheels contact the ground simultaneously; and
 - ii) the main wheels contact the ground with the nose wheel just clear of the ground. (See AMC S 479 a) 2).)
- b) [Pz max used in cases 1, 2 and 3 below is the greatest value of the landing gear reaction derived from the criterion in paragraph S 474 c).] The following drag and vertical force (in ground axes) combinations must be considered in the absence of rational analysis:
 - 1) [] Vertical = 0.6 Pz max and
drag = 0.5 Pz max;
 - 2) [] Vertical = 0.8 Pz max and
drag = -0.5 Pz max (forward);
 - 3) Maximum vertical reaction:
Vertical = Pz max and
drag = ± 0.3 Pz max.

[]

S 481 **Tail-down landing conditions**

- a) For a tail-down landing, the aeroplane is assumed to be in the following attitudes:
 - 1) For aeroplanes with tail wheels, an attitude in which the main and tail wheels contact the ground simultaneously;

- 2) For aeroplanes with nose wheels, a stalling attitude, or the maximum angle allowing ground clearance by each part of the aeroplane, whichever is less.
- b) The ground reactions are maximum vertical reaction alone, no drag force is required.

S 483 **One-wheel landing conditions**

For the one-wheel landing condition, the aeroplane is assumed to be in the level attitude and to contact the ground on one side of the main landing gear. In this attitude, the ground reactions must be the same as those obtained on that side under S 479 b). The unsymmetric ground reaction must be reacted by rolling and yawing accelerations.

S 485 **Side load condition [(See AMC S 485)]**

- a) For the side load condition, the aeroplane is assumed to be in the attitude specified in S 479 a) with only the main wheels contacting the ground, and with the shock absorbers and tyres in their static positions.
- b) The vertical limit load factor must be 1.33, with the vertical ground reaction divided equally between the main wheels. No lift is assumed.
- c) The limit side inertia factor must be 0.83, with the side ground reaction divided between the main wheels so that:
 - 1) 0.5W is acting inboard on one side; and
 - 2) 0.33W is acting outboard on the other side;

[where W is the weight of the aircraft.]

S 493 **Braked Roll – Aeroplanes with Braked Wheels**

The following braked roll conditions apply:

- a) A limit vertical load factor of 1.33 with the shock absorbers and tyres in their static positions.
- b) The attitudes and ground contacts as for level landings with all wheels on the ground.
- c) The drag reaction equal to the vertical reaction multiplied by a coefficient of friction of 0.8 applied at the ground contact point of each wheel with brakes, except that it need not exceed the maximum value corresponding to limiting brake torque.

S 499 **Supplementary conditions for nose wheels**

In determining the ground loads on nose wheels the following conditions must be met assuming that the shock absorbers and tyres are in their static positions:

- a) For aft acting loads the limit forces at the axle must be:
 - 1) a vertical component of 2.25 times the static load on the wheel; and
 - 2) a drag component of 0.8 times the vertical load.
- b) For forward acting loads the limit forces at the axle must be:
 - 1) a vertical component of 2.25 times the static load on the wheel; and
 - 2) a forward component of 0.4 times the vertical load.
- c) For sideways acting loads the limit forces at the axle must be:
 - 1) a vertical component of 2.25 times the static load on the wheel; and
 - 2) a side component of 0.7 times the vertical load in either direction.

Emergency Landing Conditions

S 561 General

- a) The aeroplane, although it may be damaged in emergency landing conditions, must be designed as prescribed in this paragraph to protect each occupant under those conditions.
- b) The structure must be designed to give each occupant every reasonable chance of escaping serious injury in a crash landing when proper use is made of belts and harnesses provided for in the design, in the following conditions:
 - 1) Each occupant experiences, separately, ultimate inertia forces corresponding to the accelerations shown in the following:

Upward : 4.5 g

Forward : 9.0 g

Sideward : 3.0 g

Downward : 4.5 g

- c) Each aeroplane with a retractable landing gear must be designed to protect each occupant in a landing with wheel(s) retracted under the following conditions:
 - 1) A downward ultimate inertia force corresponding to an acceleration of 3 g;
 - 2) A coefficient of friction of 0.5 at the ground.
- d) Except as provided in S 787, the supporting structure must be designed to restrain, under loads up to those specified in sub paragraph b) 1) of this paragraph, each item of mass that could injure an occupant if it came loose in a minor crash landing.
- e) [For configurations with the engine installed above and/or behind the seating compartment or above and/or behind the fuel tanks,] where the failure of all or part of the engine mounting structure could result in an engine following a trajectory that could pass through any part of the normal crew accommodation or fuel tanks, the attachment structure must be designed to withstand an ultimate inertia force corresponding to an acceleration of 15 g in that direction.
- f) Fuel tanks must be capable of retaining their contents under the inertia conditions of sub-paragraph b) 1).

Other Loads

S 597 Loads from single masses (See AMC S 597).

The attachment means for all single masses, which are part of the equipment of the aeroplane (including ballast) must be designed to withstand loads corresponding to the maximum design load factors to be expected from the established flight and ground loads, including the emergency landing conditions of S 561.

INTENTIONALLY LEFT BLANK

Sub-Section D Design and Construction

[General]

S 601 General

The strength of any part having an important bearing on safety and which is not amenable to simple analysis must be established by test.

S 603 Materials

The suitability and durability of materials used for parts, the failure of which could adversely affect safety, must:

- a) be established by experience or tests; and
- b) meet specifications that ensure that they have the strength and other properties assumed in the design data.

S 605 Fabrication methods

The methods of fabrication used must produce consistently sound structures which must be reliable with respect to maintaining the original strength under reasonable service conditions. If a fabrication process (such as gluing, spot welding, heat-treating, or processing of plastic materials) requires close control to reach this objective, the process must be performed under a defined process specification. Unconventional methods of fabrication must be substantiated by adequate tests.

S 607 Locking of connections

- a) A [] means of locking must be provided on all connecting elements in the primary structure and in control of other mechanical systems which are essential to safe operation of the aeroplane. []
- b) [A non-friction locking device must be used in addition to any self-locking device on connected assemblies subject to rotation in operation. (See AMC T 607.)]

S 609 Protection of structure

Each part of the structure must:

- a) be suitably protected against deterioration or loss of strength in service due to any cause, including:
 - 1) weathering;
 - 2) corrosion; and
 - 3) abrasion;
- b) have adequate provisions for ventilation and drainage; and
- c) in the case of a design employing non-metallic primary structure the applicant shall demonstrate that the structure will not become degraded from the effects of hot exhaust pipes and gases with the minimum proximity permitted by the design.

S 611 Inspection

Means must be provided to allow inspection (including inspection of principal structural elements and control systems), close examination, repair, and replacement of each part requiring maintenance, adjustments for proper alignment and function, lubrication or servicing.

S 612 Provisions for rigging and de-rigging

The design must be such that [when the aircraft is:

- i) de-rigged; and
- ii) during rigging/de-rigging

in accordance with the operator's handbook procedures,] by persons having no more than average skills, the [possibility] of damage or permanent deformation, especially when this is not readily visible, is [unlikely]. Incorrect assembly must be avoided by proper design provisions. It must be possible to inspect the aeroplane easily for correct rigging.

S 613 Material strength properties and design values

- a) Material strength properties must be based on enough tests to establish design values on a statistical basis.
- b) The design values must be chosen so that the probability of any structure being under strength because of material variations is extremely remote. (See AMC S 613 b.)
- c) Where the temperature attained in an essential component or structure in normal operating conditions has a significant effect on strength, that effect must be taken into account. (See AMC S 613 c.)
- d) Where the material used for primary structure may suffer degradation in strength and/or changes in stiffness due to environmental effects in service, due account shall be taken of these characteristics in the design.

S 619 Special factors

- a) The factor of safety prescribed in S 303 must be multiplied by appropriate combinations of the special factors prescribed in S 619 b), S 621 to S 625, S 657 and S 693. (See AMC S 619 a.)
- b) For each part of the structure not covered by S 621 to S 625, S 657 and S 693 but whose strength is:
 - 1) uncertain;
 - 2) likely to deteriorate in service before normal replacement; or
 - 3) subject to appreciable variability because of uncertainties in manufacturing processes or inspection methods; (See AMC S 619 b.)

the special factor must be chosen so that failure of the part due to inadequate strength is improbable.

S 621 Casting factors

For castings the strength of which is substantiated by at least one static test and which are inspected by visual methods, a casting factor of 2.0 must be applied. This factor may be reduced to 1.25 providing the reduction is substantiated by tests on not less than three sample castings and if these and all production castings are subjected to an approved visual and radiographic inspection or an approved equivalent non-destructive inspection method.

S 623 Bearing Factors

- a) The factor of safety for bearings at bolted or pinned joints must be multiplied by a special factor of 2.0 to provide for:
 - 1) relative motion in operation; and
 - 2) joints with clearance (free fit) subject to pounding and/or vibration.

- b) For control surface hinges and control system joints, compliance with the factors prescribed in S 657 and S 693, respectively, meets sub-paragraph a) of this paragraph.

S 625 Fitting factors

For each fitting (a part or terminal used to join one structural member to another), the following apply:

- a) For each fitting whose strength is not proven by limit and ultimate load tests in which actual stress conditions are simulated in the fitting and surrounding structures, a fitting factor of at least 1.15 must be applied to each part of:
- 1) the fitting;
 - 2) the means of attachment; and
 - 3) the bearing on the joined members.
- b) No fitting factor need be used for joint designs based on comprehensive test data (such as continuous joints in metal plating, welded joints, and scarf joints in wood).
- c) For each integral fitting, the part must be treated as a fitting up to the point at which the section properties become typical of the member.
- d) Local attachments in the load path between the safety belt or harness and the main aeroplane structure must be shown by analysis, tests, or both, to be not less strong than the strength necessary for 1.33 times the loads corresponding to the emergency alighting accelerations of S 561.
- e) When using only two hinges at each control surface, or wing-flap, the safety factor for these hinges and the attached parts of the primary structure must be multiplied by a factor of 1.5.

S 626 Cables and non-rigid members

- a) An ultimate factor of safety of 2.0 on nominal cable strength must be applied to cables used for structural applications and for all primary control systems. (See AMC S 626 a.)
- b) Where a non-rigid, non-metallic material, [e.g. textile,] is used as a primary load-carrying member (excluding the lifting surface) an ultimate factor of safety of 5.0 shall be employed.

S 627 Fatigue strength

The structure must be designed, as far as practicable, to avoid points of stress concentration and high stresses, and to take account of the effects of vibration. Materials with poor crack propagation properties must be avoided and all assemblies, especially on the primary structure, shall be readily inspectable. Flexible paints or coatings shall not be used.

S 629 Flutter prevention and structural stiffness

- a) The aeroplane must be free from flutter, aerofoil divergence, and control reversal in each configuration and at each appropriate speed up to at least V_{DF} . The control and stability of the aeroplane must not be dangerously sensitive to structural distortions and sufficient damping must be available at any appropriate speed so that aeroelastic vibration dies away rapidly.
- b) Compliance with sub-paragraph a) must be shown by:
- 1) systematic flight tests to induce flutter at speeds up to V_{DF} . These tests must show that there is no rapid reduction of damping as V_{DF} is approached.

- 2) flight tests to show that when approaching V_{DF} :
 - i) control effectiveness around all three axes is not decreasing in an unusually rapid manner, and
 - ii) no signs of approaching aerofoil divergence of wings, tailplane and fuselage result from the trend of the static stabilities and trim conditions.

Control Surfaces

S 655 Installation

- a) Movable control surfaces must be installed so that there is no interference between any surfaces or their bracings when one surface is held in any position and the others are operated through their full angular movement. This requirement must be met:
 - 1) under the limit load (positive or negative) conditions for all control surfaces through their full angular range; and
 - 2) under limit load on the aeroplane structure other than the control surfaces.
- b) If an adjustable stabiliser is used, it must have stops that will limit its range of travel to that allowing safe flight and landing.

S 657 Hinges

- a) Control surface hinges, except ball and roller bearing hinges, must have a factor of safety of not less than 6.67 with respect to the ultimate bearing strength of the softest material used as a bearing.
- b) For ball or roller bearing hinges, the approved rating of the bearing may not be exceeded.
- c) Hinges must have enough strength and rigidity for loads parallel to the hinge line. [(see AMC S 657 c).]

S 659 Mass balance

The supporting structure and the attachment of concentrated mass balance weights used on control surfaces must be designed for:

- a) 24 g normal to the plane of the control surface;
- b) 12 g fore and aft; and
- c) 12 g parallel to the hinge line.

Control Systems

S 671 General

Each control must operate easily, smoothly and positively enough to allow proper performance of its functions.

S 675 Stops

- a) Each control system must have stops that positively limit the range of motion of each movable aerodynamic surface controlled by the system.
- b) Each stop must be located so that wear, slackness, or take-up, adjustments will not adversely affect the control characteristics of the aeroplane because of a change in the range of surface travel.

- c) Each stop must be able to withstand any loads corresponding to the design conditions for the control system.
- d) On those weight shift control systems where conventional control stops cannot be provided to react pilot control input forces, it must be shown that the range of weight shift or control movement is such that the pilot cannot apply unsafe loads to the supporting structure.

S 677 Trim system

- a) Proper precautions must be taken to prevent inadvertent, improper, or abrupt trim operation. There must be means near the trim control to indicate to the pilot the direction of trim control movement relative to the aeroplane motion. In addition, there must be means to indicate to the pilot the position of the trim device with respect to the range of adjustment. This means must be visible to the pilot and must be located and designed to prevent confusion.
- b) Tab controls must be irreversible unless the tab is properly balanced and has no unsafe flutter characteristics. Irreversible tab systems must have adequate rigidity and reliability in the portion of the system from the tab to the attachment of the irreversible unit to the aeroplane structure.

S 679 Control system locks

If there is a device to lock the control system on the ground, there must be a means to:

- a) give unmistakable warning to the pilot when the lock is engaged; and
- b) prevent the lock from engaging in flight.

S 683 Operation tests

It must be shown by functional tests that the system designed to the loads specified in S 397 is free from:

- a) jamming;
- b) excessive friction; and
- c) excessive deformation;

when operating the controls from the cockpit.

S 685 Control system details

- a) Each detail of each control system must be designed and installed to prevent jamming, chafing, and interference from baggage, passengers, loose objects, or the freezing of moisture.
- b) There must be means in the cockpit to prevent the entry of foreign objects into places where they would jam the system.
- c) There must be means to prevent the slapping of cables or rods against other parts.
- d) Each element of the flight control system must have design features, or must be distinctively and permanently marked, to minimise the possibility of incorrect assembly that could result in malfunctioning of the control system.

S 687 Spring devices

The reliability of any spring device used in the control system must be established by tests simulating service conditions unless failure of the spring will not cause flutter or unsafe flight characteristics.

S 689 Cable systems

- a) Each cable, cable fitting, turnbuckle, splice, and pulley used must meet stated specifications. In addition:
- 1) No cable smaller than 2 mm diameter may be used in primary control systems;
 - 2) Each cable system must be designed so that there will be no hazardous change in cable tension throughout the range of travel under operating conditions and temperature variations; and
 - 3) There must be means for visual inspection at each fairlead, pulley, terminal, and turnbuckle.
- b) Each kind and size of pulley must correspond to the cable with which it is used. Each pulley must have closely fitted guards to prevent the cables from being misplaced or fouled, even when slack. Each pulley must lie in the plane passing through the cable so that the cable does not rub against the pulley flange. (See AMC S 689 b.)
- c) Fairleads must be installed so that they do not cause a change in cable direction of more than 3° , except where tests or experience indicate that a higher value would be satisfactory. The radius of curvature of fairleads must not be smaller than the radius of a pulley for the same cable.
- d) Turnbuckles must be attached to parts having angular motion in a manner that will positively prevent binding throughout the range of travel.

S 693 Joints

Control system joints (in push-pull systems) that are subject to angular motion, except those in ball and roller bearing systems, must have a special factor of safety of not less than 3.33 with respect to the ultimate bearing strength of the softest material used as a bearing. This factor may be reduced to 2.0 for joints in cable control systems. For ball or roller bearings, the approved ratings may not be exceeded.

S 697 Wing-flap controls

- a) Each wing-flap control must be designed so that, when the wing-flap has been placed in any position upon which compliance with the performance requirements is based, the wing-flap will not move from that position except when the control is adjusted, unless movement is demonstrated not to be hazardous.
- b) Each wing-flap must be designed to prevent inadvertent extension or movement. The pilot forces and the rate of movement at any approved flight speed must not be such as to impair the operating safety of the aeroplane.

S 701 Wing-flap interconnection

The motion of wing-flaps on opposite sides of the plane of symmetry must be synchronised by a mechanical inter-connection unless the aeroplane has safe flight characteristics with the wing-flaps retracted on one side and extended on the other.

Landing Gear

S 721 General

The aeroplane must be so designed that it can land on short grass surfaces without endangering its occupants.

Cockpit Design

S 771 General

The cockpit and its equipment must allow each pilot to perform their duties without unreasonable concentration or fatigue.

S 773 Cockpit view

Each cockpit must be designed so that:

- a) the pilot's vision is sufficiently extensive, clear and undistorted for safe operation; and
- b) rain may not unduly impair his view along the flight path in normal flight and during landing. (See AMC S 773 b.)

S 775 Windshields and windows

Windshields and windows if fitted must be constructed of a material that will not become opaque and will not result in serious injury due to splintering.

S 777 Cockpit controls

- a) Each cockpit control must be located to provide convenient operation, and to prevent confusion and inadvertent operation. [(See AMC S 777 a).]
- b) The controls must be located and arranged so that the pilot, when strapped in, has full and unrestricted movement of each control without interference from either his clothing (including winter clothing) or from the cockpit structure.
- c) In aeroplanes with dual controls it must be possible to operate the following secondary controls in both directions from each of the two pilot's seats:
 - 1) Throttle lever(s);
 - 2) Wing-flaps;
 - 3) Trim; and
 - 4) Opening and jettisoning device for the canopy. (See AMC S 777 c.)
- d) Secondary controls [(excluding foot controls)] must maintain any desired position without requiring constant attention by the pilot(s), and must not tend to creep under loads or vibration. Controls must have adequate strength to withstand operating loads without failure or excessive deflection.

S 779 Motion and effect of cockpit controls

Cockpit controls must be designed so that they operate as follows:

- a) For aeroplanes with 3-axis control systems:

Controls	Motion and effect
Roll	Right (clockwise) for right wing down
Pitch	Rearward for nose up
Yaw	Right pedal forward for nose right
Trim	Corresponding to sense of motion of the controls
Wing-flaps	Pull for wing-flaps down or extended

Controls	Motion and effect
Throttle control	Forward to increase power
Propeller pitch	Forward to increase (rpm)
Mixture	Forward, or up, for rich
Switches	Down for off

- b) For aeroplanes with other than 3-axis control systems the sense of motion of the primary controls must be defined in the Pilots Handbook. Secondary controls must comply with the sense of operation specified in S 779 a).

S 780 Colour markings of cockpit controls

Emergency controls must be coloured red.

S 785 Seats and safety harnesses

- a) Each seat and its supporting structure must be designed for an occupant weight not less than that specified by S 25 b)[, unless a higher weight is selected by the applicant,] and for the maximum load factors corresponding to the specified flight and ground conditions including the emergency landing conditions prescribed in S 561 b). (See AMC S 785 a.)
- b) Seats including cushions may not deform under the flight loads of S 333 to such an extent that the pilot is unable to reach the controls safely, or that the wrong controls are operated.
- c) The strength of the safety harness must not be less than that following from the ultimate loads for the flight and ground load conditions and for the emergency landing conditions according to S 561 b) taking into account the geometry of the harness and seat arrangement. (See AMC S 785 c.)
- d) Each safety harness must be attached so that the pilot is safely retained in his initial sitting or reclining position under flight and emergency landing accelerations. (See AMC S 785 d.)

S 786 Protection from injury

- a) Each seat and its supporting structure must be so designed that in the event of a collapse of any or all of the landing gear units the risk of serious injury to the occupant is minimised. (See AMC S 786 a.)
- b) Rigid structural members or rigidly mounted items of equipment, must be padded where necessary to protect the occupant(s) from injury during minor crash conditions.

S 787 Baggage compartment

- a) Each baggage compartment must be designed for its placarded maximum weight of contents and for the critical load distributions at the appropriate maximum load factors corresponding to the flight and ground load conditions of this BCAR Section S.
- b) Means must be provided to protect occupants from injuries by movement of the contents of baggage compartments, when subjected to ultimate inertia forces corresponding to the accelerations prescribed in S 561 b).

S 807 **Emergency exit**

- a) The cockpit must be so designed as to provide occupants with unimpeded and rapid escape in an emergency.
- b) Where the cockpit is enclosed, the opening system must be designed for simple and easy operation. It must function rapidly and be designed so that it can be operated by each occupant strapped in his seat and also from outside the cockpit.

S 831 **Ventilation**

- a) When there is an enclosed cockpit it must be designed so as to afford suitable ventilation under normal flying conditions.
- b) Carbon monoxide concentration must not exceed one part per 20 000 parts air.

INTENTIONALLY LEFT BLANK

Sub-Section E Powerplant

General

S 901 Installation

- a) Powerplant installation includes each component that:
 - 1) is necessary for propulsion; and
 - 2) affects the safety of the propulsive unit.
- b) The powerplant must be constructed, arranged and installed to:
 - 1) ensure safe operation; and
 - 2) be accessible for necessary inspections and maintenance.
- c) Electrical interconnection must be provided to prevent the existence of differences of potential between components of the powerplant and other parts of the aeroplane which are electrically conductive.
- d) In the case of turbine engines, the CAA must be consulted.

S 903 Compatibility (See AMC S 903).

The applicant must show that each engine, exhaust system and propeller combination in an aeroplane for which a Permit to Fly is sought is compatible with the aeroplane, functions in a satisfactory manner and can be operated safely within any limitations established under S 1505 and S 1521.

S 905 Protection from propeller debris deflected by the propeller (See AMC S 905).

Precautions must be taken to prevent catastrophic effect due to:

- a) the release of part of a propeller blade or a complete blade; or
- b) debris deflected by a propeller blade.

S 925 Propeller clearance [(see AMC S 925)]

If [a] propeller is installed, [] clearances at maximum weight, with the most adverse c.g., with the propeller in the most adverse pitch position and taking account of likely airframe flexibility, may not be less than the following:

- a) **Ground clearance.** There must be [adequate ground clearance] between the propeller and the ground, with the landing gear statically deflected and in the level normal, take-off, landing or taxiing attitude, whichever is most critical. In addition, there must be positive clearance between the propeller and the ground in the level take-off attitude, with:
 - 1) the critical tyre completely deflated and the corresponding landing gear strut statically deflected; and
 - 2) the critical landing gear strut bottomed and the corresponding tyre statically deflected.
- b) **Clearance from other parts of the [airframe].** There must be [adequate clearance between all rotating parts of the propeller and spinner and other parts of the aeroplane under all operating conditions with due allowance for airframe and propeller flexibility.]

[]

- c) **Clearance from occupant(s).** There must be adequate clearance between the occupant(s) and the propeller(s) such that it is not possible for the occupant(s), when seated and strapped in, to contact the propeller(s) inadvertently. It must be possible for either occupant to enter and leave the aeroplane on the ground without passing dangerously close to the propeller disc.
- d) For aeroplanes with non-rigid components, e.g. powered parachutes, the applicant shall demonstrate that it is unlikely that the non-rigid components will become entangled with any rotating part of the engine propeller system on the ground, taking due account of the recommended method of take-off. It shall be demonstrated that these non-rigid components cannot become entangled in flight.

Fuel System

S 951 General

- a) [Under normal operating conditions] each fuel system must be constructed and arranged to ensure a flow of fuel at a rate and pressure established for proper engine functioning under any normal operating condition. [(See AMC S 951 a).]
- b) Each fuel system must be arranged so that no fuel pump can draw fuel from more than one tank at a time [unless means are provided to prevent introduction of air in quantities which could cause fuel starvation].
- c) The fuel system must be arranged so that vapour locks cannot occur.

S 955 Fuel flow

- a) **Gravity systems.** The fuel flow rate for gravity systems (main and reserve supply) must be 150% of the take-off fuel consumption of the engine.
- b) **Pump systems.** The fuel flow rate for each pump system (main and reserve supply) must be at least 125% of the take-off fuel consumption of the engine at the maximum power established for take-off.

S 959 Unusable fuel

The unusable fuel quantity for each tank must be established as not less than that quantity at which the first evidence of malfunctioning occurs under the most adverse fuel feed conditions occurring during take-off, climb, approach and landing involving that tank. It shall not be greater than 5% of the tank's capacity.

S 963 Fuel tanks: general

- a) Each fuel tank must be able to withstand, without failure, the vibration, inertia, fluid and structural loads that it may be subjected to in operation.
- b) Where surging of fuel within the tank could cause significant changes in the centre of gravity of the aeroplane, means must be provided to reduce the surging to within acceptable limits.

S 965 Fuel tank tests

Each fuel tank must be able to withstand a pressure of 1½ psi without failure or leakage.

S 967 Fuel tank installation

- a) Each fuel tank must be supported so that the loads resulting from the weight of the fuel are not concentrated. In addition:
 - 1) there must be pads, if necessary, to prevent chafing between each tank and its supports; and
 - 2) materials employed for supporting the tank or padding the supporting members must be non-absorbent or treated to prevent the absorption of fuel.
- b) Each compartment containing a fuel tank must be ventilated and drained to prevent accumulation of flammable fluids and vapours. Each compartment adjacent to a tank must be treated in a similar manner.
- c) No fuel tank may be located where an engine fire could impinge on it.
- d) It must be demonstrated that the presence of the tank will in no way interfere with the operation of any part of the aeroplane, or the normal movement of the occupants and that no leaking fuel will fall directly onto any occupant.
- e) Structural damage which may result from a heavy landing in excess of the ultimate capability of the landing gear but within the emergency landing conditions of S 561 must not result in rupture of the fuel tank or fuel lines.

S 971 Fuel tank sump

- a) Each fuel tank, [unless removed for filling], must have a drainable sump which is effective in all normal ground and flight attitudes and with a capacity of 0.10% of the tank capacity, or 120 cm³, whichever is the greater. Alternatively:
 - 1) a fuel system sediment bowl or chamber that is accessible for drainage and has a capacity of 25 cm³ must be fitted, and
 - 2) it must be located so that in the normal ground attitude, water will drain from all parts of the tank to the sediment bowl or chamber, and
 - 3) each fuel tank outlet must be designed and located so that no part of the contents of the sump can enter the fuel feed line to the engine.
- b) The drainage system must be readily accessible and easy to drain.
- c) Each fuel system drain must have manual or automatic means for positive locking in the closed position.

S 973 Fuel tank filler connection

Fuel tank filler connections must be located outside personnel compartments. Spilled fuel must be prevented from entering the fuel tank compartment or any part of the aeroplane other than the tank itself.

S 975 Fuel tank vents

Each fuel tank must be vented from the top of the tank. In addition:

- a) Each vent outlet must be located and constructed in a manner that minimises the possibility of its being obstructed by ice or other foreign matter;
- b) Each vent must be constructed to prevent siphoning of fuel during normal operation;
- c) Each vent must discharge clear of the aeroplane.

S 977 Fuel strainer or filter

- a) There must be means to protect the engine from the likelihood of stoppage resulting from blockage of the fuel supply and from damage caused by debris in the fuel supply.
- b) There must be a strainer at the outlet to each tank. This strainer must have at least 6 meshes per cm (15 meshes per inch), and must be of such proportions that blockage of the fuel supply by objects entering the tank will be extremely unlikely.
- c) Each filter and each strainer must be easily accessible for drainage and cleaning.
- d) Non-metallic filter elements must be shown to be compatible with the type of fuel specified by the manufacturer. (See AMC S 977 d.)

S 993 Fuel system lines and fittings

- a) Each fuel line must be installed and supported to prevent excessive vibration and to withstand loads due to fuel pressure and accelerated flight conditions.
- b) Each fuel line connected to components between which relative motion could exist must have provisions for flexibility.
- c) Each flexible hose must be shown to be suitable for the particular application.
- d) Each fuel line and fitting in any area subject to engine fire conditions must be at least fire-resistant.
- e) Leakage from any fuel line or connection must not impinge on hot surfaces or equipment which could cause a fire, nor fall directly onto any occupant.

S 995 Fuel valves and controls

- a) There must be a means to allow the pilot to shut off rapidly in flight the fuel to the engine. (See AMC S 995 a.)
- b) The portion of the line between the fuel cock and the carburettor must be as short as possible.
- c) Each fuel cock must have either positive stops or effective detents in the 'on' and 'off' positions.
- d) If the fuel valves are not visible to the pilot, their locations must be easy to reach and instinctive to operate and there must be a placard or other visible confirmation of the valve positions. [The shut off means must be guarded against inadvertent operation.]

Oil System

S 1011 General

- a) If an engine is provided with an oil system, it must be capable of supplying the engine with an appropriate quantity of oil at a temperature not exceeding the maximum established as safe for continuous operation.
- b) Each oil system must have a usable capacity adequate for the endurance of the aeroplane.

S 1013 Oil tanks

- a) Each oil tank must be installed to:
 - 1) meet the requirements of S 967 a), b) and d); and
 - 2) withstand any vibration, inertia and fluid loads expected in operation.

- b) The oil level must be easy to check without having to remove any cowling parts (with the exception of oil tank access covers) or to use any tools.
- c) If the oil tank is installed in the engine compartment it must be made of fireproof material.

S 1015 **Oil tank tests**

Oil tanks must be subjected to the tests specified in S 965 for fuel tanks, except that in pressure tests a pressure of 5 psi must be applied.

S 1017 **Oil lines and fittings**

- a) Oil lines must comply with S 993 and each oil line and fitting must be made of fire resistant material.
- b) **Breather lines.** Breather lines must be arranged so that:
 - 1) condensed water vapour or oil that might freeze and obstruct the line cannot accumulate at any point;
 - 2) the breather discharge will not constitute a fire hazard if foaming occurs or cause emitted oil to strike the occupant(s) or the pilot's windshields;
 - 3) the breather does not discharge into the engine air induction system.

Cooling

S 1041 **General**

The powerplant cooling provisions must be able to maintain the temperatures of powerplant components and engine fluids within the temperature limit specified by the engine constructor, or as have been determined to be necessary by the aeroplane constructor, during all likely operating conditions.

Induction System

S 1091 **Air induction**

The air induction system for the engine must supply the air required by the engine under all likely operating conditions.

Exhaust System

S 1121 **General**

- a) The exhaust system must ensure safe disposal of exhaust gases without fire hazard or carbon monoxide contamination in any personnel compartment.
- b) Each exhaust system part with a surface hot enough to ignite flammable fluids or vapours must be located or shielded so that leakage from any system carrying flammable fluids or vapours will not result in a fire caused by impingement of the fluids or vapours on any part of the exhaust system, including shields for the exhaust system.
- c) Each exhaust system component must be separated by fireproof shields from adjacent flammable parts of the aeroplane.
- d) No exhaust gases may discharge dangerously near any oil or fuel system drain.
- e) Each exhaust system component must be ventilated to prevent points of excessively high temperature.

S 1125 Exhaust manifold

- a) The exhaust system must be fireproof and must have means to prevent failure due to expansion by operating temperature.
- b) The exhaust and silencing system must be supported to withstand the vibration and inertia loads to which it may be subjected in normal operation.
- c) Parts of the exhaust system connected to components between which relative motion could exist must have means for flexibility.

Powerplant Controls and Accessories

S 1141 General

- a) The portion of each powerplant control located in an engine compartment that is required to be operated in the event of fire must be at least fire-resistant.
- b) All controls for starting the engine (and stopping the engine in both normal and emergency conditions) must be easily accessible from one position so as to minimise the risk of an aircraft 'running away'.

S 1145 Ignition switches

- a) Ignition switches must control and shut off each ignition circuit on each engine.
- b) There must be a means to quickly shut off all ignition circuits on multi-engined aeroplanes by the grouping of switches or by a master control switch.
- c) All ignition switches must have a means to prevent their inadvertent operation.
- d) The ignition switch must not be used as the master switch for other circuits.

S 1149 Propeller speed

Propeller speed and pitch must be limited to values that ensure safe operation under normal operating conditions.

- a) During take-off and climb at the recommended best-rate-of-climb speed, the propeller must limit the engine rotational speed at full throttle to a value not greater than the maximum allowable rotational speed.
- b) During a glide at V_{NE} with throttle closed or the engine inoperative, the propeller must not permit a rotational speed to be achieved that is greater than 110% of the maximum allowable rotational speed of the engine or propeller, whichever is the lower.

S 1165 Engine ignition systems

Each battery ignition system must be supplemented by a generator that is automatically available as an alternative source of electrical energy to allow continued engine operation if any battery becomes depleted.

[S 1191 Firewalls

- a) Cowled engine installations must be isolated from the rest of the aeroplane by a firewall or shroud.
- b) The firewall or shroud must be constructed so that no hazardous quantity of liquid, gas or flame can pass from the engine compartment to other parts of the aeroplane.
- c) Each opening in the firewall or shroud must be sealed with close fitting, fire resistant grommets, bushings, or firewall fittings.
- d) The firewall and shroud must be fire resistant and protected against corrosion.]

S 1193 Cowling and nacelle

When an engine installation is cowled:

- a) Each cowling must be constructed and supported so that it can resist any vibration, inertia and air loads to which it may be subjected in operation.
- b) There must be a means for rapid and complete drainage of each part of the cowling in the normal ground and flight attitudes. No drain may discharge where it will cause a fire hazard.
- c) Cowling must be at least fire-resistant.
- d) Each part behind an opening in the engine compartment cowling must be at least fire-resistant for a distance of at least 600 mm aft of the opening.
- e) Each part of the cowling subjected to high temperatures due to its nearness to exhaust system ports or exhaust gas impingement, must be fireproof.

INTENTIONALLY LEFT BLANK

Sub-Section F Equipment

General

S 1301 Function and Installation

- a) Each item of required equipment must:
 - 1) be of a kind and design appropriate to its intended function;
 - 2) be installed according to limitations specified for that equipment; and
 - 3) function properly when installed. (See AMC S 1301 a) 3).)
- b) Instruments and other equipment may not in themselves, or by their effect upon the aeroplane, constitute a hazard to safe operation.
- [c) Where a single electronic display unit is used to show some or all of the required flight and navigation and powerplant instrument parameters required by BCAR S 1303 and S 1305, the following apply (See AMC S 1301 c.):
 - 1) the required instruments parameters must be displayed to the pilot at all times;
 - 2) the display must be capable of continuous reliable operation for a minimum of 20 minutes after failure of the electrical generating system;
 - 3) if a stall warning device is fitted in accordance with S 207 b), it must be independent of the electronic display; and
 - 4) failure of one sensor must not adversely affect the display of other parameters which are independent of that sensor.]

S 1303 Flight and navigation instruments

The following are required flight and navigation instruments:

- 1) An airspeed indicator,
- 2) An altimeter.

S 1305 Powerplant instruments

The following are the required powerplant instruments:

- a) Such pressure, temperature and rpm indications as the engine manufacturer may require or as are necessary to operate the engine within its limitations;
- b) A fuel quantity indicator for each fuel tank, visible by the pilot when strapped in;
- c) An oil quantity indicator for each tank. [A dipstick for each tank would be an acceptable alternative to an indicator;
- d) A manifold pressure indicator for an engine equipped with a variable pitch propeller, where manifold pressure and rotational speed are independently controllable.]

S 1307 Miscellaneous equipment

- a) All occupants must be provided with a lap strap and upper torso restraint, capable of restraining the wearer against the forces resulting from the accelerations prescribed for emergency landing conditions in S 561. (See S 625 d) and AMC S 1307 a), except that only a lap strap need be provided for front seat occupants of a weight-shift controlled aircraft.)
- b) It must not be possible for an unsecured safety harness to contact the propeller.

Instruments : Installation

S 1321 Arrangement and visibility

Flight and navigation instruments must be clearly arranged and plainly visible to each pilot.

S 1323 Airspeed Indicating System

- a) The airspeed indicating system must be calibrated.
- b) Calibration must be made in flight.
- c) The airspeed indicating system must be suitable for speeds between V_{S0} and at least 1.05 times V_{NE} .

S 1325 Pitot and static pressure systems

- a) Each instrument provided with static pressure case connections must be so vented that the influence of speed and the opening and closing of windows, moisture or other foreign matter will not significantly affect the accuracy of the instruments.
- b) The design and installation of pitot and static pressure systems must be such that:
 - 1) positive drainage of moisture is provided;
 - 2) chafing of the tubing, and excessive distortion or restriction at bends in the tubing, is avoided; and
 - 3) the materials used are durable, suitable for the purpose intended, and protected against corrosion.

S 1337 Powerplant instruments

a) Instruments and instrument lines

- 1) Each powerplant instrument line carrying flammable fluids under pressure must meet the requirements of S 993.
 - 2) Each line carrying flammable fluids under pressure must have restricting orifices or other safety devices at the source of pressure to prevent the escape of excessive fluid if the line fails.
- b) Each exposed sight gauge used as a fuel quantity indicator must be protected against damage.

Electrical Systems and Equipment

S 1353 Storage battery design and installation

- a) Each storage battery must be designed and installed as prescribed in this paragraph.
- b) No explosive or toxic gases emitted by any battery in normal operation, or as the result of any probable malfunction in the charging system or battery installation, may accumulate in hazardous quantities within the aeroplane.
- c) No corrosive fluids or gases that may escape from the battery may damage surrounding structures or adjacent essential equipment.

S 1365 Electric cables and equipment

- a) Each electric connecting cable must be of adequate capacity and correctly routed, attached and connected so as to minimise the probability of short circuits and fire hazards.
- b) Overload protection must be provided for each item of electrical equipment. No protective device may protect more than one circuit essential to flight safety.
- c) Any electrical wire that passes through a fuel tank (e.g. connected to a fuel-level probe) must be designed and installed to ensure adequate physical separation from other electrical wires. The physical separation may be achieved by separation distance or by an appropriate barrier.

S 1385 External lights

If external lights are to be installed they must be approved.

Miscellaneous Equipment

S 1431 Airborne radio and radio navigation equipment

Each item of airborne radio equipment provided must comply with the following:

- a) The equipment and its aerials may neither in themselves, nor by their mode of operation, or by their effect upon the operating characteristics of the aeroplane and its equipment, constitute a hazard to safe operation.
- b) The equipment and its control and monitoring devices must be arranged so as to be easily controllable. Their installation must be such that they are sufficiently ventilated to prevent overheating.
- c) All airborne radio equipment must be approved by the CAA.

INTENTIONALLY LEFT BLANK

Sub-Section G Operating Limitations

[General]

S 1501 **General**

- a) Each operating limitation specified in S 1505 to S 1527 and other limitations and information necessary for safe operation must be established.
- b) The operating limitations and other information necessary for safe operation must be made available to the pilot as prescribed in S 1541 to S 1585.

S 1505 **Airspeed limitations**

- a) All flight speeds must be stated in terms of airspeed indicator readings (IAS). (See AMC S 1505 a.)
- b) The never-exceed speed, V_{NE} , must not exceed 0.90 times the maximum speed demonstrated in flight tests (V_{DF}).
- c) The maximum speed demonstrated in flight V_{DF} must not exceed the Design Maximum Speed, V_D .

S 1507 **Manoeuvring speed**

The manoeuvring speed must not exceed the design manoeuvring speed, V_A , as defined in S 335 a).

S 1511 **Wing-flap operating speed**

For each positive wing-flap position, the maximum wing-flap operating speed V_{FE} must not be greater than 0.9 times the speed V_F as defined in S 335 for which the structure has been designed.

S 1515 **Landing gear operating speed**

The maximum landing gear operating speed V_{LO} , if lower than the never-exceed speed V_{NE} , must be established for retractable landing gear.

S 1519 **Weight and c.g.**

- a) The maximum weight determined under S 25 a) must be established as an operating limitation.
- b) The c.g. limitations determined under S 23 must be established as operating limitations.
- c) The empty weight and the corresponding c.g. positions must be determined in accordance with S 29.

S 1521 **Powerplant limitations**

The powerplant limitations must be established so that they do not exceed the corresponding limits specified by the engine and propeller manufacturers, except that where the aeroplane constructor has satisfactorily demonstrated that higher limitations can be used safely in his aeroplane, these may be stated.

S 1529 **Maintenance manual [(See AMC S 1529)]**

A maintenance manual containing the information that the applicant considers essential for proper maintenance must be provided. The applicant must consider at least the following in developing the essential information:

- a) Description of systems;
- b) Lubrication instructions setting forth the frequency and the lubricants and fluids which are to be used in the various systems;
- c) Pressures and electrical loads applicable to the various systems;
- d) Tolerances and adjustments necessary for proper functioning, including control surface travels;
- e) Methods of levelling, raising and ground towing;
- f) Methods of balancing control surfaces, and maximum permissible values of play at hinge pins and control circuit backlash;
- g) Identification of primary and secondary structures;
- h) Frequency and extent of inspections necessary for proper maintenance;
- i) Special repair methods applicable to the aeroplane;
- j) Special inspection techniques;
- k) List of special tools;
- l) Rigging data necessary for proper operation;
- m) Statement of service life limitations (replacement or overhaul) of parts, components and accessories subject to such limitations;
- n) The materials necessary for small repairs;
- o) Care and cleaning recommendations;
- p) Instructions for rigging and derigging;
- q) Information on supporting points and measures to be taken to prevent damage during ground transportation;
- r) List of placards and markings and their locations.

Markings and Placards

S 1541 General

- a) The aeroplane must be marked with:
 - 1) the markings and placards specified in S 1542 to S 1557; and
 - 2) any additional information, instrument markings, and placards required for safe operation.
- b) Each marking and placard prescribed in sub-paragraph a) of this paragraph:
 - 1) must be displayed in a conspicuous place; and
 - 2) may not be easily erased, disfigured, or obscured.
- c) The units of measurement used to indicate air speed on placards must be the same as those used on the indicator.

S 1542 Operating limitations placard

The following information must be placarded so that it is plainly visible to the pilot:

- a) Airspeed limitations:
 - 1) The never-exceed speed V_{NE} , and if appropriate;

- 2) The maximum speed(s) for flaps extended, V_{FE} ;
 - 3) The maximum speed for the landing gear extended, V_{LO} .
 - 4) The maximum manoeuvring speed, V_A .
- b) Powerplant limitations: such pressure, temperature, rpm and other limitations as may have been determined under S 1521.

[S 1545 **Airspeed Indicator (see AMC S 1545)**

The airspeed indicator must show the following markings:

- a) A red radial line at V_{NE} ; and
 - b) White arc from V_{S0} to V_{FE} ;
- or other method agreed with the CAA.]

S 1547 **Compass**

If a compass is fitted and unless the deviation is less than 5° on all headings, the deviation values for magnetic headings in not more than 30° increments must be placarded near the compass.

S 1549 **Powerplant instruments**

For each required powerplant instrument, as appropriate to the type of instrument, each maximum and, if applicable, minimum safe operating limit must be marked with a red radial line.

S 1553 **Fuel quantity indicator**

Each fuel quantity indicator must be calibrated to read 'zero' during level flight when the quantity of fuel remaining in the tank is equal to the unusable quantity determined in accordance with S 959.

S 1555 **Control markings**

- a) Each cockpit control, other than primary flight controls, must be clearly marked as to its function and method of operation.
- b) The colour markings of cockpit controls must be in accordance with those specified in S 780.
- c) For powerplant fuel controls:
 - 1) Each fuel tank selector control must be marked to indicate the position corresponding to each tank;
 - 2) If safe operation requires the use of any tanks in a specific sequence, that sequence must be marked on or near the selector for those tanks.

S 1557 **Miscellaneous markings and placards**

- a) **Baggage compartment.** Each baggage compartment must have a placard stating the loading limitations.
- b) **Fuel and oil filler openings.** The following apply:
 - 1) Fuel filler openings must be marked at or near the filler cover with the minimum fuel grade and fuel/oil ratio.
 - 2) Oil filler openings must be marked at or near the filler cover:
 - i) with the grade; and
 - ii) if the oil is detergent or non detergent.

- c) **Fuel tanks.** The usable fuel capacity of each tank must be marked either at the selector or on the gauge (when provided) or on the tank if this is translucent and visible to the pilot in flight.
- d) **In-flight engine starting.** A placard must be provided stating any limitations to be observed during in-flight engine starting.
- e) **Loading**
 - 1) The following data must be placarded in each aeroplane so as to be plainly visible to the pilot:
 - i) Empty weight (actual);
 - ii) Maximum weight;
 - iii) Maximum and minimum cockpit load;
 - iv) Maximum and minimum load in each seat;
 - v) Cockpit load conditions for two-seater flown solo;
 - vi) Fuel load limitations for the range of allowable cockpit loads.
 - 2) **Removable ballast.** If removable ballast is used, the place for carrying ballast must have a placard stating instructions for the proper placement and securing of the removable ballast under each loading condition for which removable ballast is necessary.
- f) **Aerobatic manoeuvres.** A placard prohibiting aerobatic manoeuvres and intentional spinning must be plainly visible to the pilot.
- [g) **Electronic displays.** Where a single electronic display unit is used to show instruments required by BCAR S 1303 and 1305, a placard instructing the pilot to land as soon as practicable in the event of electronic display failure must be plainly visible to the pilot.]

Pilot's Handbook

S 1581 General

- a) Each aeroplane must be furnished with a Pilot's Handbook . Each Pilot Handbook must at least contain the information specified in S 1583 to S 1585.
- b) **Additional information.** Any information not specified in S 1583 to S 1585 that is required for safe operation, or because of unusual design, operating or handling characteristics, must be furnished.
- c) **Units.** The units of measurement used must be the same as those used on the indicators.

S 1583 Operating limitations

- a) **Airspeed limitations.** The following limitations must be furnished: (See AMC S 1583 a.)
 - 1) The airspeed limit V_{NE} and if appropriate V_{FE} and V_{LO} together with information on the significance of those limits;
 - 2) Maximum wind limitations;
 - 3) Powerplant limitations.
 - 4) Airspeed indicator system calibration.

- b) **Weights.** The following limitations must be furnished;
 - 1) The maximum weight;
 - 2) The empty weight, the position of the empty weight c.g. and the condition of the aeroplane required to be established under S 29 b);
 - 3) The empty weight (maximum) established by reference to S 25 b) or c), whichever produces the lower value, by the procedure required by S 1585 f);
 - 4) The composition of the useful load.
- c) **Loading.** The following limitations must be furnished:
 - 1) The weight and c.g. limits required by S 23 and S 25 together with the items included in the empty weight in S 29;
 - 2) Information enabling the pilot of the aeroplane to determine, whether the c.g. and the distribution of the useful load in the different loading combinations are still within the allowable range;
 - 3) Information for the proper placement of removable ballast under each loading condition for which removable ballast is necessary.
- d) **Manoeuvres.** Authorised manoeuvres established in accordance with S 2, together with permissible ranges of wing-flap position for these manoeuvres.
- e) **Flight load factors.** The positive manoeuvring load factors:
 - 1) The factor corresponding to Point A of Figure 1 of S 333 b) to be stated to be applicable at V_A ;
 - 2) The factor corresponding to Point D of Figure 1 of S 333 b) to be stated to be applicable at V_{NE} .
- f) **Kinds of operation.** The kind of operation, e.g. V_{FR} , in which the aeroplane may be used, must be stated. The minimum equipment required for operation must be listed. In the case of powered parachutes, there must be advice to the pilot in the Pilot's Handbook regarding any limitations found necessary from flight testing in rain.
- g) **Controls.** The sense of movement of the pilot's controls and the corresponding movements of the control surfaces must be furnished.
- [h) **Electronic displays.** Where a single electronic display unit is used to show instruments required by BCAR S 1303 and 1305, an instruction to land as soon as practicable in the event of instrument failure must be furnished.]

S 1585 **Operating data and procedures**

- a) Information concerning normal and emergency procedures and other pertinent information necessary for safe operation must be furnished.
- b) The techniques to achieve safe take-off and landing and the associated distances determined under S 51 and S 75 must be furnished together with advice on the techniques to be used in crosswinds. A statement must be made of the maximum crosswind components in which take-off and landing have been demonstrated and whether control was found to be limiting. Information must be provided on a safe technique for landing with the power off.

- c) The following information must be furnished:
 - 1) The best-rate-of-climb speed, which must not be less than that used to show compliance with S 65;
 - 2) The height lost against ground distance covered, engine-off, in still air;
 - 3) The stall speed in various configurations;
 - 4) The loss of altitude from the beginning of a straight stall until regaining level flight, and the maximum pitch angle below the horizon, as determined under S 201;
 - 5) The loss of altitude from the beginning of a turning flight stall until regaining level flight as determined under S 203.
- d) If special procedures are necessary to start the engine in flight, these must be furnished.
- e) Information must be provided on safe procedures for the assembly, rigging and disassembly likely to be undertaken by the pilot before and after flight, such that inadvertent damage to the aeroplane can be avoided.
- f) Procedures for the amendment of the empty weight and composition of the useful load limitations in the Pilot Handbook and placards, including maximum fuel load to be carried, following periodic weighing of the aeroplane.
- g) Information must be provided on safe procedures for securing and ground handling of the aircraft.

Sub-Section J Propellers

Design and Construction

S 1917 **Materials**

- [a) Materials used in propeller parts affected by airworthiness requirements shall conform to specifications that ensure that they have the strength and other properties assumed in the design data.
- b) The suitability and durability of those materials must be established on the basis of experience or test.]

S 1919 **Durability**

Propeller design and construction must minimise the possibility of the occurrence of an unsafe condition of the propeller between overhauls.

S 1923 **Pitch control**

- [a) Failure of the propeller pitch control may not cause hazardous overspeeding under intended operation conditions.
- b) If the propeller can be feathered, the control system must be designed to minimise:
 - 1) consequential hazards, such as a propeller runaway resulting from malfunction or failure of the control system;
 - 2) the possibility of an unintentional operation.
- c) Failure of the propeller pitch control may not cause deterioration of the minimum climb performance under S 65.]

S 1935 **Blade retention (See AMC S 1935)**

Blade retention devices for propellers with detachable blades must be capable of withstanding a load equal to twice the centrifugal force occurring at the maximum rotational speed (other than transient overspeed) for which approval is sought, or the maximum governed rotational speed, as appropriate.

[S 1941 **Functional tests**

- a) Each variable pitch propeller (i.e. a propeller the pitch of which can be changed by the pilot or by automatic means while the propeller is rotating) must be subjected to all applicable functional tests of this paragraph. The propeller to be used in the functional test must either be driven by an engine on a test stand, or on a ground running microlight, and must be the same propeller as used in subsequent endurance tests for compliance under S 903.
- b) On the ground, the propeller must be cycled throughout the usable pitch and engine speed ranges. The total number of cycles must not be less than 50.
- c) In flight, the propeller must be cycled a minimum of 50 times through the allowable ranges of pitch and rotational speed.

S 1945 **Teardown inspection**

After the endurance tests of S 903 have been completed the propeller must be completely dis-assembled. No essential component may show rupture, cracks or excessive wear.

S 1947 Propeller adjustments and parts replacement

The applicant may service and make minor repairs to the propeller during the tests. If major repairs or replacement of parts is found necessary during the tests or in the teardown inspection, any additional tests that the CAA finds necessary must be conducted.】

Sub-Section K Microlight Parachute Recovery Systems

S 2001 **Applicability**

This Sub-Section K is applicable to emergency parachute recovery systems designed to recover a complete aeroplane in emergency situations, such as mid-air collision, loss of aeroplane control, structural failure, pilot disorientation, pilot incapacitation, engine failure etc., in circumstances where the pilot does not believe that a survivable landing can be made. It is applicable to parachute systems which are intended to be used only as a last resort to save life or to minimise serious injuries to the occupant(s), by parachuting the complete aeroplane to the ground.

The scope of these requirements is limited to ensuring that the airworthiness of the vehicle is not compromised by the installation of an emergency parachute system and to minimise the possibility of malfunction or inadvertent deployment likely to cause additional hazards to the aeroplane, its occupant(s), or personnel on the ground. The requirements do not ensure correct functioning of the parachute recovery system.

The fitment of such equipment is optional.

S 2003 **General** (See AMC S 2003).

It must be shown by analysis or test that:

- a) the airworthiness of the aeroplane, the safety of its occupant(s) and personnel on the ground will not be degraded by the installed parachute recovery system; and
- b) the installation has been designed to minimise the risk of inadvertent or uncommanded deployment or other hazardous malfunction either through in-flight structural deformation, induced vibration or by any other means.

S 2005 **Flight**

Compliance with all BCAR Section S flight requirements must be demonstrated with the recovery parachute system fitted and armed.

S 2007 **System Protection**

All components of the parachute recovery system must be provided with protection against deterioration due to weathering, vibration, corrosion, abrasion, and other causes where progressive deterioration can introduce a further hazard to the aeroplane, its occupant(s) or personnel on the ground.

S 2011 **System Inspection Provisions**

- a) Instructions for continued airworthiness must be provided for the installed system that meet the requirements of S 2029.
- b) Adequate means must be provided to permit close examination and maintenance of the parachute and other related system components, to ensure that the inherent airworthiness and safety of the aeroplane is not degraded.

S 2029 **Maintenance Manual**

- a) The maintenance manual must contain all the information necessary for proper maintenance of the parachute recovery system.
- b) The manual must require that the record of parachute system maintenance must be entered in the aeroplane log book.

- c) Instructions must be provided for inspection, adjustment and arming/disarming of the deployment mechanism, including the manufacturer's recommended maintenance intervals.
- d) Any precautions to be taken in setting, adjusting, arming/disarming or operating the system must be clearly stated.

S 2041 **Markings and Placards**

- a) The function of each parachute system control must be clearly identified by colour coding and placarding.
- b) The release control must be coloured red.
- c) The following placard must be installed adjacent to the release control:

**'WARNING – EMERGENCY PARACHUTE
(Action to be taken)
Unapproved Equipment - see Pilot's Handbook'**

- d) [Warning placards must be placed on the exterior of the aeroplane close to the stored energy device and the exit point, which are easily distinguishable by ground personnel and first responders, warning of the potential hazard. To maximise the possibility of being made aware of the danger posed by a live system following an accident, these placards should be applied to a permanent fixed part of the aircraft structure, in such a manner that at least one such placard should remain visible regardless of the stationary attitude of the aircraft.



S 2081 **Pilot's Handbook**

The Pilot's Handbook must contain the information specified in S 2083 and S 2085.

S 2083 **Operating Limitations**

Any limitations associated with the proper operation of the system must be established.

S 2085 **Operating Data and Procedures** (See AMC S 2085).

A warning must be included that the parachute recovery system installation has been approved by CAA on the basis that, whilst not deployed, it will not hazard the aeroplane, its occupant(s) or ground personnel. In addition, the warning must state that CAA has not approved the system itself or considered in what circumstances, if any, it might be deployed, and that the system has not been demonstrated to be effective in safely recovering the aeroplane, if that is the case.

INTENTIONALLY LEFT BLANK

[Supplement **Requirements for Microlight Aeroplanes to be used for Aerotowing of Hang Gliders**

Sub-Section A General

SUPP.S 1 This supplement to BCAR Section S defines the requirements applicable to aircraft designed for the purposes of aerotowing hang gliders. The supplement is arranged in the same manner as the main body of the requirements. The aircraft must comply with all normal requirements of BCAR Section S for microlight aircraft. The following additional requirements are applicable to aircraft for which approval is sought for aerotowing of hang gliders.

Sub-Section B Flight

SUPP.S 2 Compliance with all the paragraphs of Sub-Section B – FLIGHT of the main body of these requirements must be demonstrated with the most adverse combination of tug and glider except for the following requirements which are not applicable or amended as detailed below:

- | | |
|------------------|--|
| BCAR S 51 | Determined at the maximum permitted combined weights of tug and hang glider. |
| BCAR S 71 | Not Applicable |
| BCAR S 75 | Not Applicable |
| BCAR S 143 a) 5) | Not Applicable |
| BCAR S 145 c) | To read '1.1 times the maximum towing speed' (in place of V_{DF}). |
| BCAR S 147 a) | To read '1.1 times the maximum towing speed' (in place of V_{NE}). |
| BCAR S 161 | At representative climb and cruise speeds used for aerotowing, the out-of-trim control forces must not exceed those specified for prolonged application in S 143 d). |
| BCAR S 173 b) | Not Applicable |
| BCAR S 175 b) | To read '1.1 times the maximum towing speed' (in place of V_{NE}). |
| BCAR S 175 c) | Not Applicable |
| BCAR S 181 a) | To read '1.1 times the maximum towing speed' (in place of V_{DF}). |
| BCAR S 181 b) | To read '1.1 times the maximum towing speed' (in place of V_{DF}). |

- BCAR S 221 **NOTE:** If clearance for spinning is requested for the tug aircraft, account will need to be taken of the effect of the spinning characteristics of any modifications which have been made for the purpose of towing.
- BCAR S 235 A note must be included in the Pilot's Handbook, stating that in assessing suitable crosswind limits for aerotowing, the characteristics of both the tug aircraft and the hang glider must be considered.
- BCAR S 251 To read '1.1 times the maximum towing speed' (in place of V_{DF}).
- SUPPS 3 The aeroplane must be safely controllable and manoeuvrable when the hang glider is released, either deliberately or inadvertently, during any phase of flight.

Sub-Section C Structure

- SUPP.S 4 The general requirements of BCAR S 601 to S 629 are applicable to the design of the towing equipment.
- SUPPS 5 The aeroplane shall have Proof and Ultimate Factors of not less than 1.0 and 1.5 respectively when loads equal to 1.2 times the nominal strength of the cable or weak link are applied through the towing hook installation in the directions specified below, simultaneously with the loads arising from the critical normal accelerations (as defined in Sub-Section C) at the maximum towing speed:
- Horizontally backwards;
 - Backwards and upwards at 45° to the horizontal;
 - Backwards and downwards at 30° to the horizontal;
 - Horizontally backwards and at 30° sideways in both directions.
- SUPPS 6 The strength of the cable or that of any weak link(s) that may be interposed in the cable shall be established and shall be stated in the Pilot's Handbook; however, the strength of the cable or weak link shall not be less than 981 N (100 kgf).

Sub-Section D Design and Construction

- SUPP.S 7 The towing hook shall be of a quick release type.
- SUPP.S 8 The prototype installation shall be tested for satisfactory operation with loads equal to 10% and 100% of the nominal weak link strength applied to the towing hook in any direction prescribed in SUPP. S 5 It must be established that when the release control is operated:
- The cable will be released.
 - The released cable will be unlikely to cause damage or become entangled with any part of the aeroplane.
 - The release loads are within the range of loads prescribed in SUPP. S 12. (See AMC SUPP. S 8).

- SUPP.S 9 If the towing hook is not of a type already approved for towing purposes, the reliability of the device must be established by a test programme agreed with CAA.
- SUPPS 10 Operation of the release control must be convenient for the pilot, located to prevent confusion or inadvertent operation and shall be coloured yellow.
- SUPP.S 11 The pilot must have full and unrestricted access to the release control when strapped in, and there must be no interference from clothing (including winter clothing) or structure.
- SUPP.S 12 The pilot effort necessary to operate the release control shall not be less than 20 N and not greater than 130 N when the tow cable is loaded in all possible directions and magnitudes, specified in SUPP. S 5.
- SUPP.S 13 The propeller clearances of BCAR S 925 must be maintained when the prescribed loads and directions of SUPP. S 5 are applied and released, including the effects of springback of deformed structure.
- SUPP.S 14 Unless it can be demonstrated that there is no possibility of the tow cable becoming entangled in the propeller whilst taxiing, including turns at minimum turning radius, means to prevent such entanglement must be provided.
- SUPP.S 15 It must be demonstrated by test that the cable when released in the air, will fall clear of the aeroplane and will not cause damage or become entangled with the propeller or aircraft structure.

Sub-Section E Powerplant

- SUPPS 16 Unless it can be shown that engine temperatures will not be exceeded in the conditions approved for towing, a means must be provided to monitor the critical engine temperature.

Sub-Section G Operating Limitations and Information.

- SUPP.S 17 a) The following limitations must be established and stated in the Pilot's Handbook:

- 1) Maximum weight of glider to be towed;
- 2) Permitted tow speed range*;
- 3) Maximum weak link strength;
- 4) Powerplant cooling limitations*;
- 5) Maximum number of occupants of the tug aircraft and/or allowable cockpit load*.

Those marked thus (*) must be marked on the aircraft by suitable placards or instrument markings.

- b) The following limitations are applied in all cases:

- 1) The CAA will accept operations conducted in accordance with the British Hang-Gliding and Paragliding Association (BHPA) Aerotow Manual. Any other operations must be agreed with the CAA.
- 2) Minimum tow line length is 50 metres

SUPP.S 18 The Pilot's Handbook for the aeroplane must be amended to reflect the information associated with aerotowing. The following must be included:

- a) A definition and description of the required equipment;
- b) Instructions for rigging and derigging (if applicable);
- c) Limitations (changed or additional);
- d) Procedural information (normal/emergency);
- e) Recommended operating techniques;
- f) Any unusual or special precautions to be taken whilst towing;
- g) Effect on the performance of the aeroplane;
 - 1) Take-off distance
 - 2) Climb Rate
- h) Effect on the weight and c.g. of the aeroplane;
- i) Additional maintenance requirements.]

Part 2 Acceptable Means of Compliance and Interpretative Material (AMC)

Sub-Section B Flight

AMC S 21 (Interpretative Material)

- 1) Instrumentation for flight test
 - a) For test purposes the aeroplane should be equipped with suitable instruments for conducting the required measurements and observations in a simple manner. If reliable results cannot be obtained otherwise, the CAA may request the installation of special test equipment.
 - b) At an early stage in the programme the accuracy of the instruments and their correction curves should be determined, and particular attention should be paid to the position error of the airspeed indication system; the influence of the configuration of the aeroplane should also be accounted for.
- 2) Prior to flight test, the following ground tests should be conducted:
 - a) Measurement of:
 - i) Control circuit stiffness (as set out in S 411);
 - ii) Friction of controls;
 - iii) Control cable tension of closed control circuits; and
 - iv) Maximum deflection of control surfaces, wing flaps and their respective controls.
- 3) **Functioning tests.** Before starting the flight tests all ground functioning tests should be carried out.
- 4) **Aeroplane attitudes.** Rates of change of attitude and references to 'the nose' should be interpreted as relating to the attitude of the wing.

AMC S 21 a) (Interpretative Material)

Where the manufacturer can show that there is no trend towards instability with decreasing pilot weight, then a certain amount of extrapolation downwards would normally be acceptable to the CAA in lieu of actual testing of the lighter weights.

AMC S 23 b) (Interpretative Material)

The use of removable ballast in order to show compliance with this requirement is not acceptable.

[AMC S 25 c) (Interpretative Material)]

Maximum fuel is a variable quantity which is to be established and placarded according to the procedures set down in paragraph S 1585 f). On initial manufacture, maximum fuel will equate to full fuel i.e. the capacity of the tank.】

AMC S 51 (Interpretative Material)

The distance presented in the Pilot's Handbook should be the mean of six demonstrations increased by a factor of 1.3.

AMC S 143 b) (Interpretative Material)

In the case of powered parachutes, it should be demonstrated that it is not hazardous to operate the aeroplane in moderately heavy rain.

AMC S 143 d) (Interpretative Material)

For weight shift control systems and other unconventional control systems it may not be possible for the pilot to apply the pilot efforts given in the table. In these cases the pilot efforts for temporary and prolonged applications must be agreed with the CAA.

[AMC S 145 d) (Interpretative Material)

This requirement may be demonstrated by a taxiing test:

First the wing keel must be balanced so that there is no static pitching moment about the hang point. The trike should then be driven into wind on as smooth a surface as possible. The zero lift angle of incidence can be gauged by observing the point at which the sail changes from its loaded to unloaded shape, or by measurement e.g. with a load cell in part of the structure. The range of angles of attack can be determined by using a tape measure at the control bar; the force acting at each angle of attack can be measured with a spring balance. A graph should then be plotted of bar force vs. wing incidence. Alternatively this requirement may be met by testing the wing according to the DULV, DHV, BHPA or USHGA pitch testing requirements at or above the V_{S0} speed for the microlight wing. Note that the force required to contain the pitching of the wing should remain a pull force at all incidences.

AMC S 181 c) (Interpretative Material)

The long period or phugoid oscillation is characteristically lightly damped, sometimes even unstable. Mild levels of instability are acceptable as long as they do not significantly interfere with normal piloting tasks such as trimming to a desired speed or holding altitude. Useful guidelines are that the oscillation should be near neutrally stable if the period is less than 15 seconds, or, for motions with longer period, the time to double amplitude should be greater than 55 seconds.】

AMC S 201 c) (Interpretative Material)

The loss of altitude during the stall is the difference between the altitude at which the stall occurs and that altitude at which level flight is regained.

[AMC S 201 d) 4) (Interpretative Material)

An extreme nose-up attitude is normally considered to be a pitch attitude of more than 30°.】

AMC S 203 a) (Interpretative Material)

The roll will be considered to be uncontrollable if the aeroplane rolls more than a further 30° into the turn or more than a total of 60° out of the turn.

Sub-Section C Structure

AMC S 307 a) (Interpretative Material)

- 1) Substantiating load tests made in accordance with S 307 a) should normally be taken to ultimate design load.
- 2) The results obtained from strength tests should be so corrected for departures from the mechanical properties and dimensions assumed in the design calculations as to establish that the possibility of any structure having a strength less than the design value, owing to material and dimensional variation, is extremely remote.

[AMC S 321 (Interpretative Material)

Compliance with CS VLA paragraphs 321–459, 572, 1505, 1511, 1545 and 1583 a) will be accepted in lieu of BCAR S 321–455, S 1505, S 1511 and S 1583 a).]

AMC S 321 b) (Interpretative Material)

Altitude is not normally critical for flight loads; propeller torque and thrust are normally greatest at sea level.

AMC S 337 (Interpretative Material)

Unless more rational distribution of lift can be substantiated, the following should be used. In all cases, account may be taken of appropriately distributed inertia relief:

- 1) Rigid-wing aircraft:
 - a) The spanwise distribution should be assumed to be proportional to the variation of wing chord.
 - b) The chordwise distribution is to be that which gives the most critical condition within the following ranges of centre of pressure:
 - i) For positive load cases, 20% to 60% chord;
 - ii) For negative load cases, leading edge to 25% chord.
- 2) Flexwing aircraft:
 - a) The spanwise distribution should be assumed to be proportional to the variation of wing chord and, for both positive and negative load cases, the chordwise position of centre of pressure is to be at 50% chord.
 - b) Distortion of flexwings may lead to significant changes in the applicable flight envelope and point A may not be attainable below V_D . Where such cases are proven the limit load factor may be lowered to the maximum value attainable below V_D .
- 3) Powered parachutes:

For powered parachute canopies, the load distribution applied normal to the local mean surface, defined by taking the mean of the upper and lower surfaces of a double-surfaced canopy may be distributed as follows:

 - a) The spanwise distribution should be assumed to be:
 - i) In proportion to the local chord and, separately;
 - ii) A modified triangular distribution. This is defined in the following diagram:

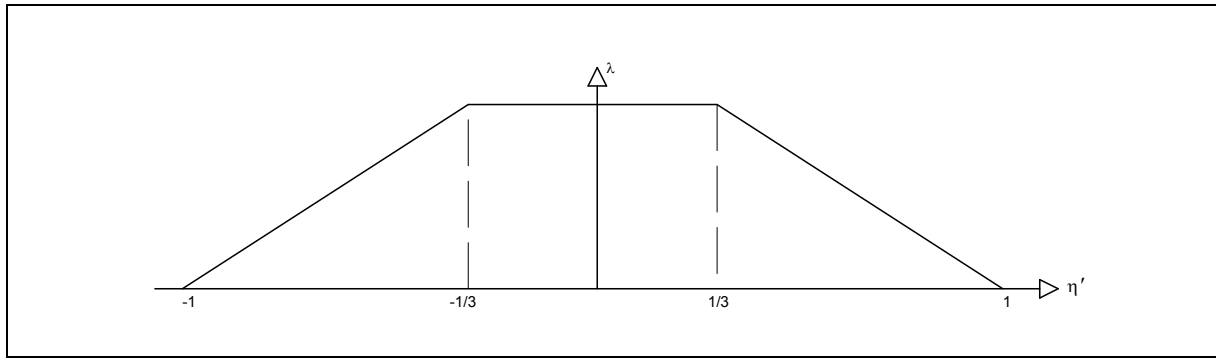

where; η' = Fraction of semi-span of the canopy when laid flat

λ = Local load per unit flat span

For both the above load distributions, the total vertical component of the load on the canopy in its flying configuration should be equal to nW where n is the appropriate manoeuvre factor and W is the design maximum weight, i.e. for a chordwise strip of flat span $\Delta y'$:

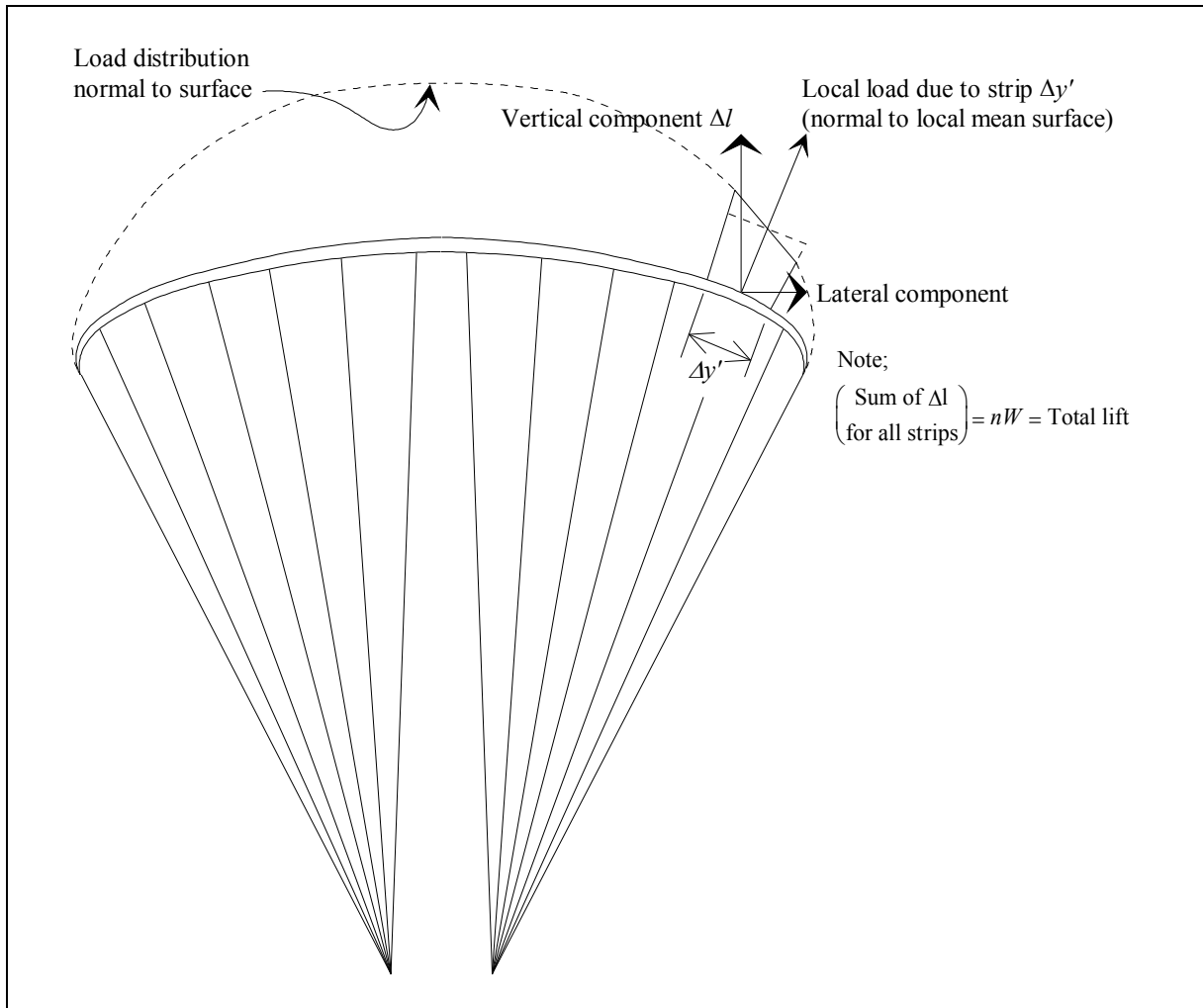

- [b) For chordwise distribution, the following loads cases should be considered:
- i) the load is distributed evenly across the chord;
 - ii) the load is distributed evenly over the forward 1/3rd of the chord.]

AMC S 347 (Interpretative Material)

The aeroplane is assumed to maintain its attitude after the controls have been activated to initiate roll or yaw until the resulting incremental loads have reached their highest value.

[AMC S 349 (Interpretative Material)

(Weightshift aircraft only.) Each component affected should be designed to meet the load in the base bar and sidewires due to the greatest possible lateral pilot input added to the flight load at N1.

AMC S 397 (Interpretative Material)

For unconventional control systems, the design loads should reflect the most sensible mode of operation for the control, e.g. depending on the sense of operation, a 3-axis hand-operated rudder should be designed for the loads appropriate for either a pitch or roll control.]

AMC S 405 (Interpretative Material)

Hand and foot loads assumed for design should not be less than the following:

- 1) Hand loads on small hand-wheels, cranks etc. applied by finger or wrist-force:
 $P = 15 \text{ daN}$
- 2) Hand loads on levers and hand-wheels applied by the force of an unsupported arm without making use of body weight: $P = 35 \text{ daN}$
- 3) Hand loads on levers and hand-grips applied by the force of a supported arm or by making use of the body weight: $P = 60 \text{ daN}$
- 4) Foot loads applied by the pilot when sitting with his back supported (e.g. toe-brake operating loads): $P = 75 \text{ daN}$.

AMC S 411 (Interpretative Material)

- [a) Under the maximum possible air load for each control system, deformations of the control system should not adversely affect the controllability of the aircraft.
- b) Under the design load for each control system, deformations should not prevent loads being transmitted to the point where they would normally be reacted.]

AMC S 423 (Interpretative Material)

[]The loads should be calculated for instantaneous deflection of the pitch control, the following cases being considered:

- 1) Speed V_A , maximum upward deflection;
- 2) Speed V_A , maximum downward deflection;
- 3) Speed V_D , one-third maximum upward deflection;
- 4) Speed V_D , one-third maximum downward deflection.

The following assumptions should be made:

- a) The aeroplane is initially in level flight, and its attitude and airspeed do not change;
- b) The loads are balanced by inertia forces.

AMC S 447 (Interpretative Material)

For aeroplanes where the horizontal stabilising surfaces are arranged considerably above or below the centre of area of the vertical stabilising surfaces, the stabilising surfaces and their supporting structure including the rear portion of the fuselage should be designed to withstand combined horizontal and vertical loads. In this case, the prescribed loadings on the vertical stabilising surfaces and the roll moments induced at the horizontal stabilising surfaces should be accounted for.

AMC S 471 (Interpretative Material)

Compliance with CS VLA 471–521 and 723–757 will be accepted in lieu of BCAR S 471–499.

AMC S 473 (Interpretative Material)

- 1) Where the shock absorber characteristics are not essentially affected by the rate of compression, static tests may be used to establish compliance.
- 2) In the absence of a more rational analysis, the energy to be absorbed horizontally by the nose gear, as required by paragraph S 473 c), may be assumed to be 50% of the total vertical energy referred to in S 473 a).
- 3) The rational use of S 473 b) 2) requires either an instrumented drop test or some form of analysis. Although the nose wheel is just clear of the ground at the start of the impact this will obviously not be the case as the impact develops and the gear responds. To find the energy absorbed by the nose gear in these circumstances by analysis would require accurate knowledge of the inertia distribution of the airframe and also detailed understanding of the behaviour of all the landing gear elements, and a time history analysis would then need to be developed. If evaluated by drop test then the closure of the nose gear elements would need measurement (tyre, leg, airframe if flexible) and the observed performance of the nose gear would then be compared with the results of a calibrated nose gear drop test to identify the energy absorbed.

AMC S 474 (Interpretative Material)

For clarity, the following force diagram is included:

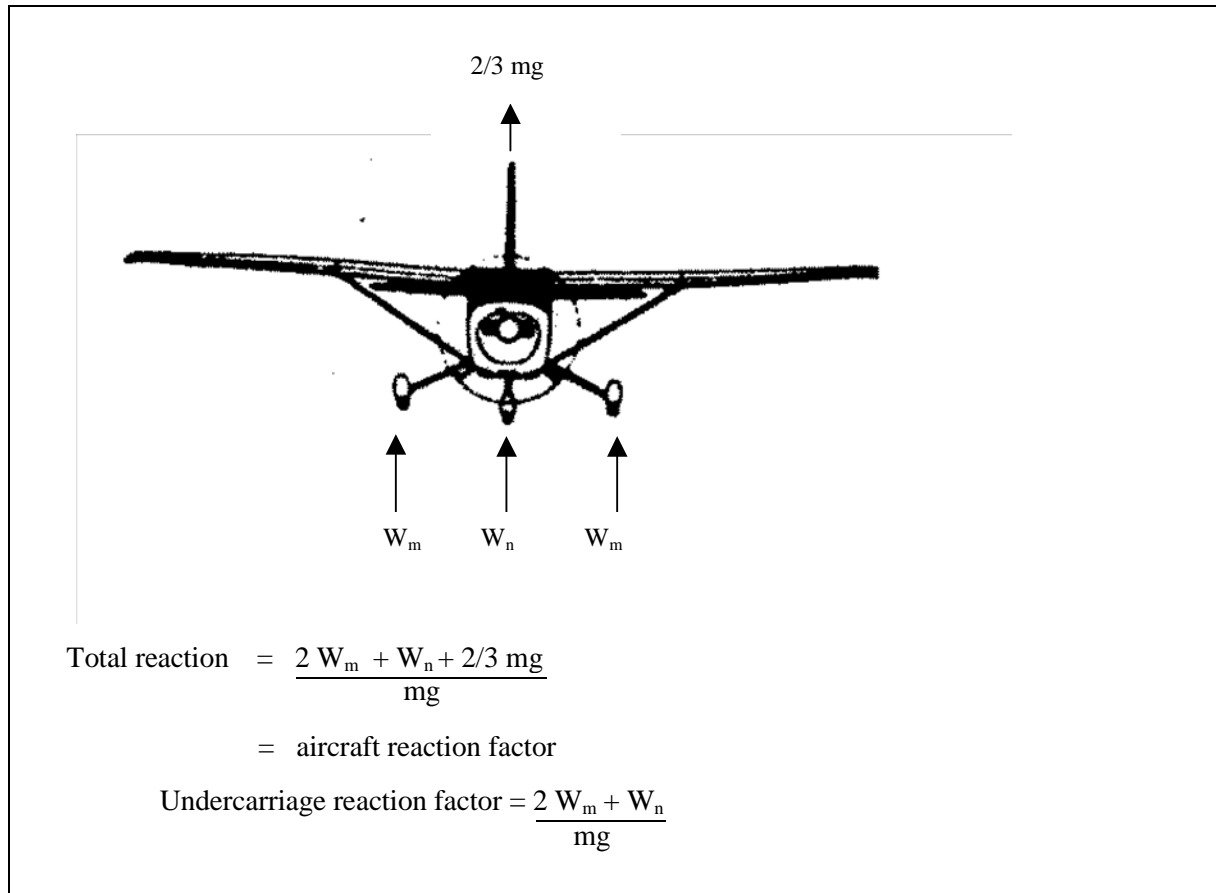

AMC S 479(a)(2) (Interpretative Material)

For aeroplanes with nose wheels, the same attitude may be used in both sub-paragraphs i) and ii) but in the analysis associated with sub-paragraph ii) the nose gear reaction is to be assumed to remain zero.

[AMC S 485 (Interpretative Material)

The effect of yawing acceleration due to side loads during landing should be considered to act on the whole aircraft structure.

AMC S 597 (Interpretative Material)

Ballast includes (but is not limited to) removable ballast and will be considered as part of the equipment of the aeroplane and therefore subject to compliance with the requirements of Section S in general and S 561 d) and S 597 in particular.

INTENTIONALLY LEFT BLANK

Sub-Section D Design and Construction

[AMC S 607 b) (Interpretive Material)

A self-locking stiff nut and plain washer combination, when subject to rotation, may be considered an acceptable means of compliance when used in conjunction with a 'torque stripe' applied to the connection in those circumstances where:

- 1) no de-torque force either cyclic or continuous is applied to the connected assembly; and
- 2) that assembly is clearly visible to inspection; and
- 3) failure cases such as a bearing or sleeve seizure should be considered during application and interpretation of 607 b).

Rotation:

May include but not be limited to:

- 1) Any connection subject to rotation about the axis of the connecting elements;
- 2) Any connection subject to angular oscillation about the axis of the connecting elements.

Torque stripe:

- 1) A 'torque stripe' is a clearly visible continuous line applied to and running down the axis of connecting elements that would show, without ambiguity, if the connecting elements have been disturbed from their original position.
- 2) A torque stripe is not a means of locking but an inspection aid.
- 3) A 'torque stripe' shall be of a medium that can be easily applied and identified.
- 4) A 'torque stripe' shall be fit for purpose and not easily removed during normal operating conditions.]

AMC S 613 b) (Interpretive Material)

Material specifications should be those contained in documents accepted either specifically by the CAA or by having been prepared by an organisation or person which the CAA accepts has the necessary capabilities. In defining design properties these material specification values should be modified and/or extended as necessary by the constructor to take account of manufacturing practices (for example method of construction, forming, machining and subsequent heat treatment).

AMC S 613 c) (Interpretive Material)

Air temperatures up to 54°C are considered to correspond to normal operating conditions.

AMC S 619 a) (Interpretive Material)

Appropriate combinations of the special factors should include all those of the following appropriate to the part:

- 1) The casting factor derived in accordance with S 621;
- 2) The highest pertinent special factor prescribed in S 619 b), S 623, S 625, S 657 or S 693; and
- 3) The two-hinge factor prescribed in S 625 e).

AMC S 619 b) (Interpretative Material)

For the substantiation of composite structures, unless more rational means are agreed by the CAA, one of the following may be used:

- 1) An additional factor of 1.2 for moisture conditioned specimen tested at maximum service temperature, providing that a well established manufacturing and quality control procedure is used;
- 2) An additional factor of 1.5 for specimen tested with no specific allowance for moisture and temperature.

AMC S 626 a) (Interpretative Material)

Nominal cable strength is defined by the minimum breaking load for the particular type of cable specified in the British Standard or other acceptable recognised specification to which the cable is made. Reference to the relevant specification must be made in the design documentation.

These criteria are applicable to steel cables. Design assumptions for cables of other materials should be agreed with the CAA.

AMC S 657 c) (Interpretative Material)

Compliance may be shown by applying the accelerations under S 659 c).

AMC S 689 b) (Interpretative Material)

The inside diameter of the pulley groove should not be less than 300 times the diameter of the largest elemental strand.

AMC S 773 b) (Interpretative Material)

Compliance with S 773 b) may be provided by the canopy having a suitable opening.

AMC S 777 a) (Interpretative Material)

For unconventional control systems, the function and sense of the control should be placarded.

AMC S 777 c) (Interpretative Material)

When a trim system is fitted, the requirement for it to be available to both pilots may be waived if it can be demonstrated that, with the trimmer in the most adverse position, the control forces are sufficiently small and that there is no difficulty in control.

AMC S 785 a) (Interpretative Material)

Although 86 kg is the minimum pilot weight for design, the typical weight of equipped and heavier crew should be considered.

AMC S 785 c) and d) (Interpretative Material)

These requirements should be read in conjunction with paragraph S 1307.

AMC S 786 a) (Interpretative Material)

The seat support structure should be designed, as far as is practicable, so as to prevent spinal or other serious injuries to the occupant in a minor crash landing in which the landing gear may have collapsed. It is recommended that rigid structural members are not located in a position likely to cause injury in such a crash landing and that energy absorbent materials should be used under the seat structure to reduce the impact loads being applied to the occupant's spine.

Sub-Section E Powerplant

AMC S 903 (Interpretative Material)

Evidence of safe and satisfactory operation of the engine, exhaust system and propeller combination in the aeroplane for a period of 25 hours' flying without significant problems is an acceptable means of demonstrating compliance.

AMC S 905 (Interpretative Material)

These precautions should provide protection from catastrophic effects resulting from impact by debris within the region defined by lines passing through the propeller hub making angles of at least 20° forward and aft of the plane of rotation of the propeller. Within this region at least the following should be considered:

- 1) Where a tear in a tension membrane could be catastrophic to the aircraft, steps should be taken to prevent propagation of the tear to the point where the aircraft is endangered.
- 2) If ground debris thrown up by the undercarriage can pass through the propeller, steps should be taken to reduce to an acceptably low level the likelihood of this occurring.
- 3) The vulnerability of critical components should be considered with respect to location, duplication and separation.

AMC S 925 (Interpretative Material)

- a) Ground clearance.

There should be a ground clearance of at least 180 mm (for an aeroplane with a nose-wheel landing gear) or 230 mm for an aeroplane with a tail-wheel landing gear.

- b) Clearance from other parts of the airframe.

- 1) There must be at least 25 mm radial clearance between the blade tips and other parts of the aeroplane, plus any additional radial clearance necessary to prevent harmful vibration, and at least 100 mm radial clearance from flying or landing wires or other items capable of large deflections, when they are fully deflected to minimise the clearance.
- 2) There must be at least 13 mm longitudinal clearance between the propeller blades or cuffs and other parts of the aeroplane.
- 3) It should be demonstrated by a test including engine start up and running that, at the most adverse conditions, there is a minimum longitudinal propeller clearance, allowing for airframe and propeller flexibility, varying linearly between 13 mm at the hub and 50 mm at the blade tip.

[AMC S 951 a) (Interpretative Material)

Consideration should be given to the effects of take-off, climb, descent and uncoordinated manoeuvres on the requirement to maintain fuel feed. This is particularly relevant for tanks with large horizontal lower surfaces at low fuel states. Use of internal or external feeder tanks (including large gascolators), adequate collector volume or additional pick-ups may assist in maintaining fuel flow and preventing entrainment of air. Integral tanks in wings with dihedral less than 5 degrees may be particularly problematic in this regard unless such measures are considered.]

AMC S 977 d) (Interpretative Material)

Additives in many two-stroke engine oils can, under certain conditions, produce materials which will block paper filter elements with pore sizes of less than 10 microns. Such paper elements will not be considered compatible with two-stroke pre-mix fuel systems.

AMC S 995 a) (Interpretative Material)

In tandem seating configurations, a large adult should be strapped into the other seat during the demonstration.

Sub-Section F Equipment

AMC S 1301 a) 3) (Interpretative Material)

- 1) The correct functioning should not be impaired by sub-zero temperatures, heavy rain or high humidity.
- 2) When radio equipment is installed it should be shown that the electrical system is such that the operation of this equipment is not adversely affected.

[AMC S 1301 c) (Interpretative Material)

Where a single electronic display unit is used to show some or all of the required flight and navigation and powerplant instrument parameters required by BCAR S 1303 and S 1305, the reliability of the single electronic display should be shown to be at least equivalent to traditional instruments.]

AMC S 1307 a) (Interpretative Material)

Installation of Shoulder Harness

Figures 1, 2 and 3 show the recommended installation geometry for this type of restraint.

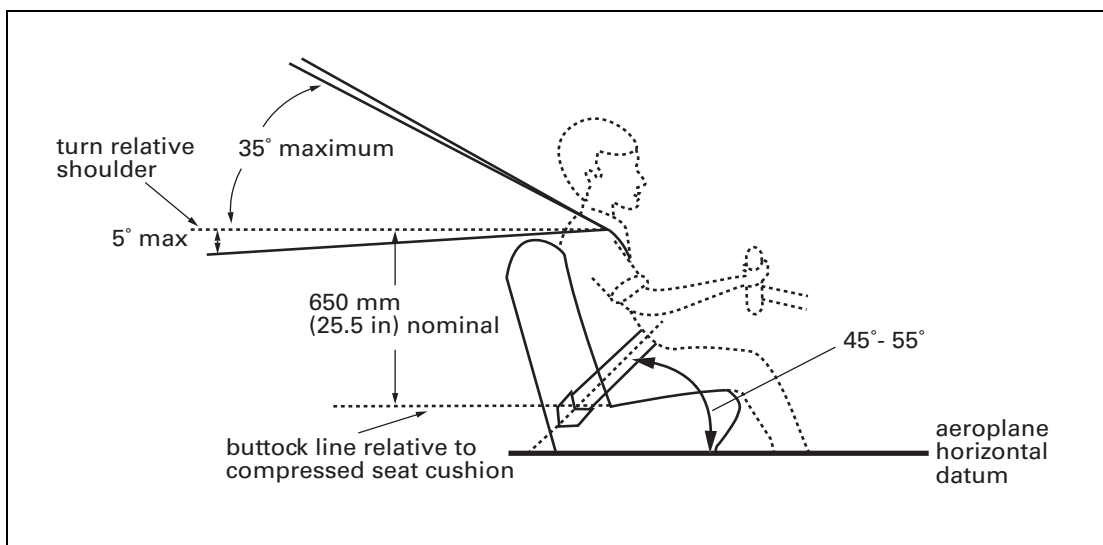

Figure 1

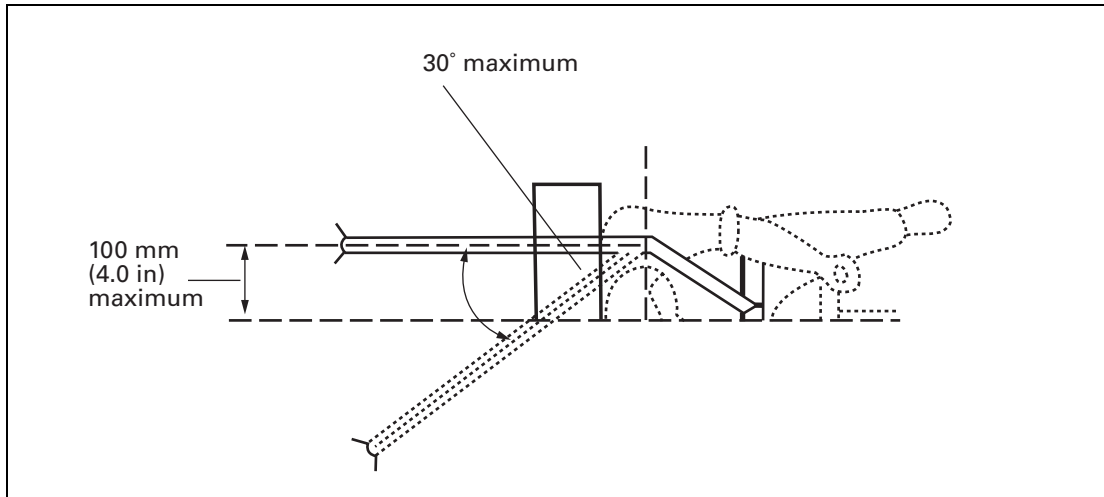

Figure 2 Range of Angles of Shoulder Straps

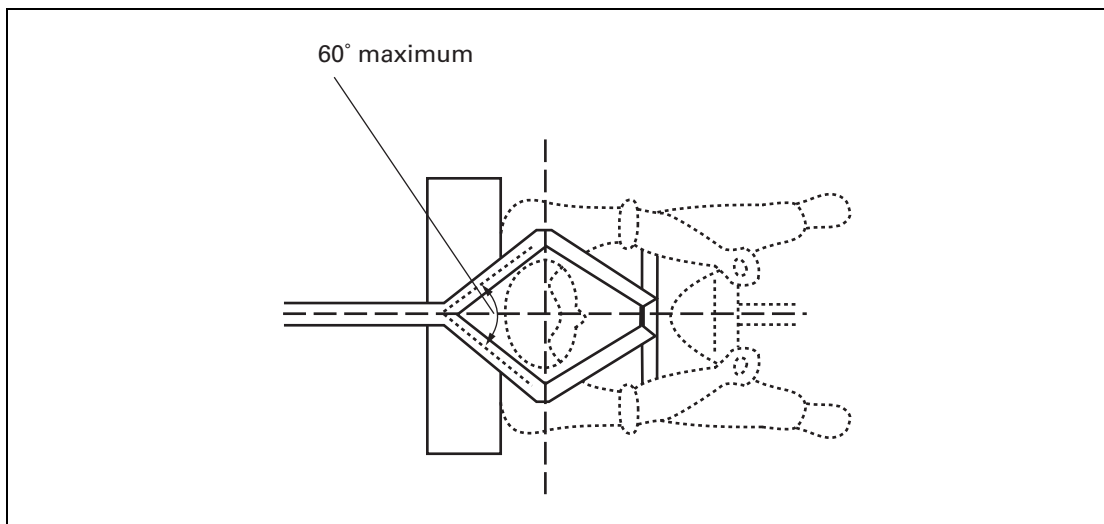

Figure 3

Figures 1, 2 and 3 show the recommended installation geometry for this type of restraint.

- NOTES:**
- 1) Where possible it is recommended that a negative g or crotch strap is fitted, otherwise during abrupt decelerations the shoulder straps tend to raise the belt portion (unless tightly adjusted) from around the hips on to the stomach, thus allowing the wearer to slide underneath the lap portion of the belt.
 - 2) Where there is more than 152 mm (6 in) of webbing between the attachment point of the shoulder straps, and the top of the seat back, suitable means should be provided to limit sideways movement e.g. guide loops, to ensure adequate separation of shoulder straps to minimise injury or chafing of the wearer's neck.
 - 3) Where the seat back is of adequate strength and such height that the harness geometry relative to the shoulder conforms with the above Figure (i.e. 650 mm (25.5 in)), it is permissible to attach the shoulder straps to the seat back via guide loops to the aeroplane floor.
 - 4) Where the seat back is of adequate strength the use of means, e.g. guide loop of suitable strength, will limit sideways movement during the emergency alighting accelerations of S 561.

Sub-Section G Operating Limitations

AMC S 1505 a) (Interpretative Material)

Speeds (EAS) determined from structural limitations should be suitably converted.

[AMC S 1529 (Interpretative Material)]

Manuals containing the information essential for servicing and maintaining the engine and propeller should also be provided.]

[AMC S 1545 (Interpretative Material)]

- 1) Powered parachutes tend to be single speed machines so in these cases ASI with markings may not be required.
- 2) In the case of digital/non-analogue ASIs, the means of marking should be discussed with the CAA.]

AMC S 1583 a) (Interpretative Material)

The significance of V_{NE} and V_A should be stated in relation to permissible aileron, elevator and rudder application.

INTENTIONALLY LEFT BLANK

Sub-Section J Propellers

AMC S 1935 Blade Retention (Interpretative Material)

The pull load should be twice the maximum centripetal load multiplied by the ultimate factor. No other material factors of S 613 need apply.

INTENTIONALLY LEFT BLANK

Sub-Section K Microlight Parachute Recovery Systems

[AMC S 2003 (Interpretive Material)]

The installation designer is advised that consideration should be given to:

- 1) the ability of each seat and restraint system required by S 1307 to protect the occupant(s) from serious injury during an emergency descent with the parachute deployed.
- 2) the ability of the attachment point and associated structure to withstand the loads arising from a worst case correct deployment.
- 3) minimising the possibility of parachute entanglement with parts of the aeroplane during deployment. If contact with any other part of the aeroplane, including the propeller, is likely to occur during or following deployment, it should be shown that such contact is not hazardous to the occupant(s).
- 4) the attitude that the suspended aeroplane will adopt during an emergency descent.
- 5) the ability of the parachute to fulfil its intended purpose.
- 6) the design of the installation so that deployment can only occur on the clear intent of the pilot or passenger. Factors to be considered should include:
 - a) The security of the mounting to take account of in-service conditions such as heavy landings or taxiing on rough terrain;
 - b) The routing of the release cable to ensure that it is free from engine and flight control interference and is well secured along its path;
 - c) The design of the release control. The release action should take the form of two separate and distinct actions that can be carried out quickly and with one hand, such as a twist and pull action. For systems incorporating a single action release mechanism, compliance with S 2003 may be acceptable provided that the release control is fitted with a stowage that either provides the additional action or is designed to minimise the possibility of snagging from clothing, personal equipment, or by parts of the aeroplane;
 - d) The positioning of the release control so as to minimise the snagging hazard, bearing in mind the possible ground attitudes that the aeroplane could adopt following an accident;
 - e) The positioning of the release control to make it accessible to both pilot and passenger;
 - f) The provision of a safety pin or similar mechanical locking device to prevent unintentional deployment of the system during ground operations.]

[AMC S 2085 (Interpretative Material)]

An acceptable text for the warning in the Pilot's Handbook is as follows:

'Occupant Warning – The parachute recovery system installation has been approved by CAA on the basis that, as far as is practicable to demonstrate, it will create no hazard to the aeroplane, its occupant(s) or ground personnel whilst the system is not deployed; and that when properly maintained, the risk of malfunction, deterioration or inadvertent deployment is minimised. The CAA has not approved the system itself or considered the circumstances, if any, in

which it might be deployed. The effectiveness of the system for the safe recovery of the aeroplane has not been demonstrated.']

Supplement Requirements for Microlight Aeroplanes to be used for Aerotowing of Hang Gliders

[AMC SUPP. S 8 (Interpretative Material)]

It is recommended that the release mechanism be designed so that the hook will release automatically if the angular limits specified in SUPP. S 5 are exceeded in operation by more than 10%.]

INTENTIONALLY LEFT BLANK