

Safety Regulation Group

CAP 643

British Civil Airworthiness Requirements

Section T Light Gyroplanes

Safety Regulation Group

CAP 643

British Civil Airworthiness Requirements

Section T Light Gyroplanes

Issue 5

© Civil Aviation Authority 2013

All rights reserved. Copies of this publication may be reproduced for personal use, or for use within a company or organisation, but may not otherwise be reproduced for publication.

To use or reference CAA publications for any other purpose, for example within training material for students, please contact the CAA at the address below for formal agreement.

ISBN 978 0 11792 828 2

Issue 1, 29 March 1995

Amendment No. 1 to Issue 1, August 2001

Issue 2, 15 August 2003 No technical changes, document has been restructured

Issue 3, 12 August 2005

Issue 4, 29 July 2011

Issue 5, 9 May 2013

Enquiries regarding the content of this publication should be addressed to:
Airworthiness Strategy and Policy, Safety Regulation Group, Civil Aviation Authority, Aviation House,
Gatwick Airport South, West Sussex, RH6 0YR.

The latest version of this document is available in electronic format at www.caa.co.uk, where you may also register for e-mail notification of amendments.

Published by TSO (The Stationery Office) on behalf of the UK Civil Aviation Authority.

Printed copy available from:

TSO, PO Box 29, Norwich NR3 1GN
Telephone orders/General enquiries: 0844 477 7300
Fax orders: 0870 600 5533

www.tsoshop.co.uk
E-mail: caa@tso.co.uk
Textphone: 0870 240 3701

List of Effective Pages

Part	Sub-Section	Page	Date	Part	Sub-Section	Page	Date
		iii	Revised 9 May 2013				
Contents		1	Revised 9 May 2013	Part 1	Sub-Section F	4	9 May 2013
Contents		2	Revised 9 May 2013	Part 1	Sub-Section F	5	9 May 2013
Foreword		1	Revised 29 July 2011	Part 1	Sub-Section G	1	Revised 9 May 2013
Foreword		2	Revised 9 May 2013	Part 1	Sub-Section G	2	Revised 9 May 2013
Preambles		1	Revised 12 August 2005	Part 1	Sub-Section G	3	Revised 29 July 2011
Preambles		2	Revised 9 May 2013	Part 1	Sub-Section G	4	Reissued 9 May 2013
Abbreviations and Definitions		1	Revised 29 July 2011	Part 1	Sub-Section G	5	Revised 9 May 2013
Abbreviations and Definitions		2	Revised 29 July 2011	Part 1	Sub-Section G	6	9 May 2013
Part 1	Sub-Section A	1	Revised 9 May 2013	Part 1	Sub-Section J	1	Revised 9 May 2013
Part 1	Sub-Section B	1	Revised 9 May 2013	Part 1	Sub-Section J	2	9 May 2013
Part 1	Sub-Section B	2	Reissued 9 May 2013	Part 2	Sub-Section A	1	Revised 29 July 2011
Part 1	Sub-Section B	3	Reissued 9 May 2013	Part 2	Sub-Section B	1	Revised 29 July 2011
Part 1	Sub-Section B	4	Reissued 9 May 2013	Part 2	Sub-Section B	2	Revised 29 July 2011
Part 1	Sub-Section B	5	Revised 9 May 2013	Part 2	Sub-Section B	3	Revised 29 July 2011
Part 1	Sub-Section B	6	Revised 9 May 2013	Part 2	Sub-Section B	4	29 July 2011
Part 1	Sub-Section B	7	Reissued 9 May 2013	Part 2	Sub-Section B	5	Revised 29 July 2011
Part 1	Sub-Section C	1	Revised 29 July 2011	Part 2	Sub-Section B	6	Revised 29 July 2011
Part 1	Sub-Section C	2	Revised 9 May 2013	Part 2	Sub-Section B	7	Revised 9 May 2013
Part 1	Sub-Section C	3	Revised 9 May 2013	Part 2	Sub-Section B	8	Revised 9 May 2013
Part 1	Sub-Section C	4	Reissued 9 May 2013	Part 2	Sub-Section B	9	9 May 2013
Part 1	Sub-Section C	5	Reissued 9 May 2013	Part 2	Sub-Section C	1	Revised 29 July 2011
Part 1	Sub-Section C	6	Reissued 9 May 2013	Part 2	Sub-Section C	2	Revised 9 May 2013
Part 1	Sub-Section C	7	Reissued 9 May 2013	Part 2	Sub-Section D	1	Revised 9 May 2013
Part 1	Sub-Section C	8	Reissued 29 July 2011	Part 2	Sub-Section D	2	Reissued 9 May 2013
Part 1	Sub-Section D	1	Revised 9 May 2013	Part 2	Sub-Section D	3	Revised 9 May 2013
Part 1	Sub-Section D	2	Reissued 9 May 2013	Part 2	Sub-Section D	4	9 May 2013
Part 1	Sub-Section D	3	Reissued 9 May 2013	Part 2	Sub-Section E	1	Revised 29 July 2011
Part 1	Sub-Section D	4	Reissued 9 May 2013	Part 2	Sub-Section E	2	Revised 9 May 2013
Part 1	Sub-Section D	5	Revised 9 May 2013	Part 2	Sub-Section E	3	9 May 2013
Part 1	Sub-Section D	6	Reissued 9 May 2013	Part 2	Sub-Section F	1	Revised 9 May 2013
Part 1	Sub-Section D	7	Revised 9 May 2013	Part 2	Sub-Section F	2	Reissued 9 May 2013
Part 1	Sub-Section D	8	Revised 9 May 2013	Part 2	Sub-Section F	3	9 May 2013
Part 1	Sub-Section D	9	9 May 2013	Part 2	Sub-Section G	1	Revised 9 May 2013
Part 1	Sub-Section E	1	Revised 29 July 2011	Part 2	Sub-Section G	2	9 May 2013
Part 1	Sub-Section E	2	Revised 9 May 2013	Part 2	Sub-Section J	1	Revised 29 July 2011
Part 1	Sub-Section E	3	Revised 9 May 2013				
Part 1	Sub-Section E	4	Revised 9 May 2013				
Part 1	Sub-Section E	5	Revised 9 May 2013				
Part 1	Sub-Section E	6	Revised 9 May 2013				
Part 1	Sub-Section E	7	Revised 9 May 2013				
Part 1	Sub-Section E	8	9 May 2013				
Part 1	Sub-Section E	9	9 May 2013				
Part 1	Sub-Section F	1	Revised 9 May 2013				
Part 1	Sub-Section F	2	Revised 9 May 2013				
Part 1	Sub-Section F	3	Revised 9 May 2013				

INTENTIONALLY LEFT BLANK

Contents

	List of Effective Pages	iii
	Foreword	
	Preambles	
	Abbreviations and Definitions	
	Abbreviations	1
	Definitions	2
Part 1	Requirements	
	Sub-Section A General	
	Sub-Section B Flight	
	General	1
	Performance	2
	Controllability and Manoeuvrability	3
	Stability	5
	Ground Handling Characteristics	6
	Miscellaneous Flight Requirements	7
	Sub-Section C Structure	
	General	1
	Flight Loads	2
	Control Surfaces and System Loads	3
	Stabilizing and Control Surfaces	3
	Ground Loads	4
	Main Component Requirements	6
	Emergency Landing Conditions	7
	Fatigue Evaluation	8
	Other Loads	8
	Sub-Section D Design and Construction	
	General	1
	Control Surfaces and Rotors	3
	Control Systems	4
	Cockpit Design	6

Sub-Section E Powerplant

General	1
Fuel System	2
Oil System	5
Cooling	6
Induction System	6
Exhaust System	7
Powerplant Controls and Accessories	7

Sub-Section F Equipment

General	1
Instruments: Installation	2
Electrical Systems and Equipment	3
Safety Equipment	5
Miscellaneous Equipment	5

Sub-Section G Operating Limitations and Information

General	1
Markings and Placards	2
Pilot's Handbook	4

Sub-Section J Propellers

Design and Construction	1
-------------------------	---

Part 2 Acceptable Means of Compliance and Interpretative Material (AMC)

Sub-Section A General

Sub-Section B Flight

Sub-Section C Structure

Sub-Section D Design and Construction

Sub-Section E Powerplant

Sub-Section F Equipment

Sub-Section G Operating Limitations and Information

Sub-Section J Propellers

Foreword

1 General

- 1.1 British Civil Airworthiness Requirements (hereinafter referred to as the 'Requirements') of which Section T is a constituent part, are published by the Civil Aviation Authority (hereinafter referred to as the 'CAA'). They comprise minimum requirements and constitute the basis for the issue of Certificates, Permits and Approvals in accordance with the Air Navigation Order.
- 1.2 This Code is applicable only to those gyroplanes that are excluded from regulation by the European Aviation Safety Agency under Regulation (EC) No. [216/2008] Article 4 and Annex II.
- 1.3 This BCAR Section T for Light Gyroplanes has been based on BCAR Section S, which is applicable to microlight aeroplanes, suitably amended to cover gyroplanes, and is intended to reflect a similar level of airworthiness. Where appropriate, rotorcraft requirements have been included which align with FAR/JAR-27.
- 1.4 Gyroplanes which have been shown to comply with BCAR Section T will only be eligible for a Permit to Fly.

2 Recognition

Recognition will be accorded to light gyroplanes designed, manufactured and tested in accordance with technical standards or regulations of other [states, which ensure an equivalent level of safety. The results of checks and tests carried out by suitably qualified and approved bodies and laboratories of other states] will be taken into consideration where such results provide a level of accuracy, fitness and suitability for purpose equivalent to the results of tests carried out in the United Kingdom and where such bodies and laboratories offer a suitable and satisfactory guarantee of technical and professional competence and understanding.

3 Interpretation

- 3.1 These requirements, with or without explanatory material, should not be regarded as constituting a textbook of current aeronautical knowledge; interpretation of the requirements against a background of such knowledge is essential.
- 3.2 Where necessary, the mandatory requirements have been supplemented by interpretative material, which give acceptable interpretation of requirements, state recommended practices or give supplementary information.
- 3.3 Mandatory clauses are invariably denoted by the use of 'shall' or 'must', 'should' or 'may' are used in the text to indicate permissive or recommended clauses.
- 3.4 It is implicit in requirements expressed qualitatively (e.g. 'readily visible', 'adequately tested') that the CAA will adjudicate in cases where doubt exists.

4 Presentation

4.1 Arrangement of Requirements

4.1.1 This BCAR Section T is divided into 2 Parts: Part 1 – Requirements and Part 2 – Acceptable Means of Compliance and Interpretative Material (AMC). Part 1 is further divided into eight Sub-Sections which are reflected in Part 2.

4.1.2 Where there is AMC material that relates to the whole paragraph, reference to it will appear after the main paragraph title. If there is AMC material that only relates to certain sub-paragraphs, reference will appear after the affected paragraphs.

4.2 Editorial

As far as possible, BCAR Section T paragraphs carry the same number as the equivalent paragraph in FAR/[CS-27], or FAR/[CS-23], whichever is applicable.

4.3 S.I. units

S.I. units have been used in these requirements.

NOTE: Strict observance of the S.I. system is not compatible with current aeronautical practice, in which performance data are scheduled. Consequently, some variations from S.I. units will be found in Sub-Section B.

5 Amendment and Issue

5.1 The printed version of the Section, which is identified by an Issue No. and date will be deemed to be amended by each BCAR Amendment, appropriate to the Section, which is issued subsequent to the date of issue of the printed version.

[]

5.2 Material differences from the previous issue of each page are indicated with [bold square brackets].

5.3 The issue or revision date is indicated at the foot of each page. The significance of the wording is as follows:

- a) [(Date) - Date of first issue of that page.]
- b) Revised (Date) – Revisions, indicated by bold square brackets, have been introduced at the revision date.
- c) Reissued (Date) – The text on the page has not changed from the previous issue or amendment, but the page has been reissued because of movement of text on the page.

6 Effective Date

New requirements and amendments promulgated in BCAR Amendments are effective from the date printed on them. Thus, for any application made on or after the date of issue of a printed version of the Section, the effective requirements will be made up of those in the printed version of the Section together with those in any appropriate BCAR Amendments which are current at the time the application is made.

Preambles

Section T

Issue 1

29 March 1995

BCAR Section T is the basis for the issue of Permits to Fly for new types of light gyroplane, application for approval of which is received after the above date. The basis for the issue of Certificates of Airworthiness for small rotorcraft will continue to be JAR-27.

Issue 1 of BCAR Section T presents the technical intent of BCAR Paper T860, and is made effective upon acceptance of the advice of the Airworthiness Requirements Board.

Amendment 1

31 August 2001

Amendment 1, dated 31 August 2001, of Issue 1 of BCAR Section T incorporates Working Draft Paper T897 into the text.

This regulation was notified in draft to the European Commission in accordance with Directive 98/34/EC (formerly 83/189/EEC 19834 O.J. L109/8), (as amended).

Issue 2

12 August 2005

Issue 2 contains **no new technical changes** from those incorporated in the amendment to issue 1. The publication has however been restructured to mirror the layout of Joint Aviation Requirements (JAR) codes and European Aviation Safety Agency (EASA) Certification Specifications. Marginal lines have been replaced with bold square brackets. The AMC material has been moved to a separate section and references to any AMC material inserted against the relevant paragraph/s. The pages have been re-dated to show the applicability date of any technical material contained in them.

[Issue 3

12 August 2005

Issue 3 of BCAR Section T, dated 12 August 2005, incorporates Working Draft Paper T925 into the text.

Paper T925 was prepared to adopt those changes made to BCAR Section S that could be seen as equally applicable to BCAR Section T, to accommodate results of research into gyroplane longitudinal stability and experience gained in the application of existing requirements to particular projects.

In order to mirror Joint Aviation Requirements (JAR) codes and European Aviation Safety Agency (EASA) Certification Specifications, bold square brackets have continued to be used in place of marginal lines to show changes in the text.

New AMC material has been inserted and references inserted against the relevant paragraphs.

Editorial changes have also been included in this Issue.]

Issue 4

29 July 2011

Issue 4 of BCAR Section T, dated 29 July 2011, incorporates Working Draft Paper T 957 into the text.

Paper T 957 introduces advisory material where it is considered to be necessary as well as a number of changes arising from an increased understanding of the flight characteristics of gyroplanes. This understanding was gained during CAA Flight Department investigations into the stability of gyroplanes and an investigation into rotor teeter behaviour carried out by Glasgow University.

Some of the changes have been developed to address areas of inconsistency within the current requirements and are implemented to improve the applicability to current gyroplane designs.

Paper T 957 was prepared to adopt changes made to BCAR Section S that are also considered to be applicable to BCAR Section T.

Some editorial changes convenient to be included at this time have also been incorporated.

[Issue 5

(xx) April 2013

Issue 5 of BCAR Section T, dated 9 May 2013 incorporates Working Draft Paper T 967 into the text.

Paper T 967 introduces requirements to address AAIB Recommendations regarding doors inadvertently opening in flight, and advisory material for seat requirements.

This Paper also introduces a number of changes to allow the use of variable pitch propellers based upon changes made to BCAR Section S at Issue 5, as some of the requirements and guidance material therein are equally applicable to gyroplanes.

Clarification of the requirements and guidance material along with editorial changes convenient to be made at this time, have also been incorporated.】

Abbreviations and Definitions

[Abbreviations

C_N	Aerodynamic normal force coefficient.
EAS	Equivalent airspeed. True airspeed $\times (\frac{p}{p_0})^{1/2}$ where p is the air density and p_0 is the air density in standard sea-level conditions.
IAS	Indicated airspeed. The readings of the pitot-static airspeed indicator as installed in the rotorcraft, corrected only for instrument error.
ISA	International Standard Atmosphere.
V_D	The Maximum Design Speed, EAS.
V_{DF}	The Maximum Demonstrated Flight Speed, EAS. This must not exceed V_D .
V_H	Maximum speed in level flight with the engine at maximum continuous power, IAS.
VMC	Visual Meteorological Conditions.
V_{MC} (power-off)	The minimum power-off control airspeed (IAS) at which control of the aircraft is assured in all axes following failure of the engine, including transient effects experienced at the point of failure.
V_{MC} (power-on)	The minimum power-on control airspeed (IAS) at which control of the aircraft is assured in all axes with the engine producing the power required to maintain the flight condition.
V_{MIN}	Minimum Level Flight Speed, IAS, limited by either power or controllability considerations.
V_{NE}	The Never Exceed Speed, IAS.
V_Y	Best Rate of Climb Speed, IAS.]

[Definitions

Fireproof

'Fireproof' with respect to materials, components and equipment, means the capability to withstand the application of heat by a flame, for a period of 15 minutes without any failure that would create a hazard to the aircraft.

Compliance with the criteria for fireproof materials or components should be shown as follows:

- 1) The flame to which the materials or components are subjected should be $1100^{\circ}\text{C} \pm 80^{\circ}\text{C}$.
- 2) Sheet materials approximately 64 cm^2 should be subjected to the flame from a suitable burner.
- 3) The flame must be large enough to maintain the required test temperature over an area approximately 13 mm^2 .

For example, materials which are considered fireproof without being subjected to fire tests include:

- a) stainless steel sheet 0.4 mm (0.016 in) thick;
- b) mild steel sheet protected against corrosion 0.45 mm (0.018 in) thick; and
- c) titanium sheet 0.45 mm (0.018 in) thick.

Fire-resistant

'Fire-resistant' with respect to materials, components and equipment means the capability to withstand the application of heat by a flame, as defined for 'Fireproof', for a period of 5 minutes without any failure that would create a hazard to the aircraft.

For materials this may be considered to be equivalent to the capability of withstanding a fire at least as well as aluminium alloy, in dimensions appropriate for the purposes for which they are used.

Primary Structure

Those parts of the structure, the failure of which would endanger the gyroplane.]

Part 1 Requirements

Sub-Section A General

T 2 **Applicability**

a) This Section T states requirements applicable to gyroplanes having:

- 1) not more than two occupants;
- 2) a maximum all-up (take-off) weight not exceeding 600 kg; and
- 3) restricted to day VMC.

For the purpose of UK airworthiness requirements, such gyroplanes are referred to as 'light' gyroplanes.

b) A gyroplane is defined as a rotorcraft with a non-power-driven rotor rotating about an axis which is vertical or nearly so, when the aircraft is in horizontal flight.

c) These requirements apply to light gyroplanes of orthodox design. Aircraft having the following basic features will be so regarded:

- 1) Single teetering two-bladed rotor of fixed pitch. (See AMC T 2 c)1.);
- 2) Single reciprocating engine which may be normally-aspirated, turbo-supercharged or supercharged (see AMC T 2 c) 2)) and [driving a fixed or variable pitch] propeller; and
- 3) One nose wheel and/or tail wheel, and non-retractable two-main-wheel undercarriage;
- 4) Pusher or tractor configuration.

d) If an aerodynamic pitch control system, (other than by the rotor), which is operable in flight is fitted, then the gyroplane will not be considered to be of orthodox design. (See AMC T 2 d.)

e) Where it can be shown that a particular feature is similar in all significant respects to one which is part of a previously accepted design, and can be considered as a separate entity in terms of its function, the CAA will take this into account when assessing the acceptability of the feature, and it may then not be necessary to test or otherwise substantiate to the level set out in the appropriate requirement.

f) Where these requirements are inappropriate to particular design and construction features, it will be necessary to reconsider the validity of the requirements for each particular case and the CAA must be consulted as to the applicable requirements.

g) Permitted Operations.

These requirements apply to light gyroplanes designed for non-aerobatic operation. (See AMC T 2 g.)

INTENTIONALLY LEFT BLANK

Sub-Section B Flight

General

T 21 **Proof of compliance** (See AMC T 21.)

- a) Unless a combination of weight and centre of gravity (c.g.) is specified, each requirement of this Sub-Section must be met by test upon a gyroplane of the type for which a Permit to Fly is requested, at the most adverse combination of weight and c.g. within the range of loading conditions within which the gyroplane will be operated.
- b) Compliance must be established for all configurations at which the gyroplane will be operated, except as otherwise stated.

NOTE: Flight tests may also be required to show compliance with requirements of other Sub-Sections of BCAR Section T.

T 23 **Load distribution limits** (See AMC T 23.)

- a) The ranges of weight and c.g. within which the gyroplane is to be safely operated must be selected by the applicant. Such ranges must include both fore/aft and vertical c.g. positions for all possible loading configurations, and establish and record the relationship between c.g. and the propeller thrust line.
- b) The c.g. range must not be less than that which corresponds to the weight of each occupant, varying between a minimum of 55 kg weight for a pilot alone up to the maximum placarded weight for a pilot and passenger, together with a variation in fuel contents from zero to full fuel. The placarded maximum weight must be not less than [90] kg per person.
- c) [If the design of the gyroplane permits significant lateral asymmetry of loading, the lateral limits for c.g. position must be established.]

T 25 **Weight limits**

Maximum weight. The maximum weight must be established so that it is:

- a) not more than:
 - 1) the highest weight selected by the applicant;
 - 2) the design maximum weight, which is the highest weight at which compliance with each applicable structural loading condition and each applicable flight requirement is shown.
- b) not less than the weight which results from the empty weight of the gyroplane [established under T29], plus a weight of occupant(s) of [90] kg for a single-seat gyroplane or [180] kg for a two-seat gyroplane [] plus fuel for at least 60 minutes flight at maximum continuous power.
- c) not less than the weight which results with one ([90] kg pilot) occupant, required minimum equipment and maximum fuel. (See AMC T 25 c.)

T 29 **Empty weight and corresponding c.g.**

- a) The empty weight and corresponding c.g. must be determined by weighing each gyroplane:
 - 1) with:

- i) fixed ballast;
 - ii) required minimum equipment; and
 - iii) unusable fuel, maximum oil and, where appropriate, engine coolant and hydraulic fluid; and
- 2) excluding the weight of the occupant(s).
- b) The condition of the gyroplane at the time of determining empty weight must be one that is well defined and easily repeated, and must be specified in the weighing report which demonstrates compliance with these requirements.

T 31 Removable ballast

Removable ballast may be used in showing compliance with the flight requirements of this Sub-Section.

T 33 Rotor speed limits

- a) A range of rotor speed limits must be established which permits any expected manoeuvre to be performed safely over the ranges of airspeed, all-up weight and altitude within which it is intended that the gyroplane shall be operated.
- b) At the critical combinations of weight, altitude and airspeed for any permitted manoeuvre the rotor speed must remain within the established safe range.

Performance

T 45 General

The performance prescribed in this Sub-Section B must be determined:

- a) with normal piloting skill under average conditions;
- b) for still air at sea level in the standard atmosphere;
- c) at the most critical weight;
- d) with the most unfavourable c.g. for each condition; and
- e) using engine power not in excess of the maximum declared for the engine type, and without exceeding powerplant and propeller limitations established under T 1521.

T 51 Take-off (See AMC T 51.)

The distance(s) required from rest, to take-off from, and climb to 15 m above, a dry, level, short grass surface, with zero wind, must be determined using flight technique(s) selected by the Applicant.

T 65 Climb

The time for climb from leaving the ground up to 1000 ft above the field must be determined and when corrected to the international standard day conditions at sea level, must not exceed four minutes with not more than take-off power and without exceeding temperature limits established under T 1041.

T 71 [Rate of descent]

The minimum rate of descent, and the associated airspeed, in a power-off, en-route configuration at maximum weight and minimum practicable operating weight must be determined.

T 73 Minimum speed for level flight

The minimum airspeed for level flight V_{MIN} must be determined. This speed must not be less than the minimum control speed ($V_{MC (power-on)}$) established under T 149. (See AMC T 73.)

T 75 Landing distance

The distance required to land and come to rest from a point 15 m above the landing surface, with zero wind, must be determined. An approach speed must be specified.

T 79 Height-speed envelope (See AMC T 79.)

If there are any combinations of height and forward speed of V_{MIN} and greater, from which a safe landing cannot be made following engine failure, a limiting height-speed envelope must be established.

Controllability and Manoeuvrability

T 143 General

a) The gyroplane must be safely controllable and manoeuvrable with sufficient margin of control movement and rotor clearance to correct for atmospheric turbulence and to permit control of the attitude of the gyroplane at all power settings at the critical weight and c.g., at sea level and at the maximum altitude at which the gyroplane will be operated:

- 1) during steady flight at speeds between $V_{MC (power-on)}$ or $V_{MC (power-off)}$, whichever is the lowest, and V_{DF} (See AMC T 143 a) 1).)
- 2) during speed changes;
- 3) during changes of engine power, (including sudden loss of engine power). (See AMC T 143 a) 3) and b).); and
- 4) during any manoeuvre appropriate to the type, including:
 - i) take-off;
 - ii) climb;
 - iii) turning flight;
 - iv) descent (power-on and power-off) including vertical and spiral descents;
 - v) landing (power-on and power-off);
 - vi) recovery to power-on flight from a balked approach; and
 - vii) during dynamic manoeuvres including steep turns, straight pull-outs, and roll reversals.

b) It must be possible to maintain any required flight condition and make a smooth transition from one flight condition to another (including turns, slips and reversal of turns) with no more than average piloting skill, alertness or strength, and without danger of exceeding the limit manoeuvring load-factor, under any operating condition probable for the type, with the engine running at all possible associated power settings within the allowable range, including the effect of power changes and sudden engine failure.

If $V_{MC (power-on)}$ is less than $V_{MC (power-off)}$ (see T 149), it must be demonstrated that it is possible, without exceptional pilot skill or strength, to recover the aircraft

to $V_{MC (power-off)}$ after the engine has been made inoperative at $V_{MC (power-on)}$. (See AMC T 143 a) 3) and b).)

Likely variations from any recommended techniques must not cause unsafe flight conditions.

- c) Any unusual flying characteristics observed during the flight tests required to determine compliance with the flight requirements must be investigated.
- d) 1) The controls must not exhibit excessive breakout force, friction or free play.
 2) There must be no overbalance of the yawing, pitching and rolling controls.
- e) A technique must be established, and demonstrated, for landing the gyroplane at maximum all-up weight, with the engine stopped, without hazard to the occupants.
- f) The gyroplane shall not exhibit any serious tendency to enter a Pilot-Induced Oscillation (PIO) at all power settings at the critical weight and c.g., at sea level and at the maximum altitude at which the gyroplane will be operated:
 - 1) during steady flight at speeds between $V_{MC (power-on)}$ or $V_{MC (power-off)}$, whichever is the lowest, and V_{DF} ;
 - 2) during speed changes;
 - 3) during changes of engine power, (including sudden loss of engine power); and
 - 4) during any manoeuvre appropriate to the type, including:
 - i) take-off;
 - ii) climb;
 - iii) turning flight;
 - iv) descent (power-on and power-off) including vertical and spiral descents;
 - v) landing (power-on and power-off);
 - vi) recovery to power-on flight from a balked approach; and
 - vii) during dynamic manoeuvres including steep turns, straight pull-outs, and roll reversals.

T 145 Longitudinal lateral and directional control

- a) It must be possible at any speed below $1.3 V_{MIN}$ to pitch nose downwards so that a speed equal to $1.3 V_{MIN}$ can be reached promptly. This must be shown at all possible configurations and engine powers when trimmed at $1.3 V_{MIN}$ (where trim control is fitted).
- b) It must be possible to raise the nose at V_{DF} at all permitted c.g. positions and engine powers.
- c) If marginal conditions exist with regard to pilot effort, the control forces must be assessed by quantitative tests, with the engine running at all allowable powers. (See AMC T 145 c).)
- d) The maximum wind speed, maximum cross wind and maximum tail wind (if applicable), must be established in which the gyroplane can be operated, without the loss of control, on or near the ground in any manoeuvre appropriate to the type (such as cross wind take-off), with:
 - 1) critical weight; and

- 2) critical c.g.

These wind velocities must be specified in the Pilot's Handbook.

T 149 Minimum control speed (See AMC T 149)

The following minimum control speeds must be determined:

- a) minimum power-off control speed, $V_{MC (power-off)}$;
- b) minimum power-on control speed, $V_{MC (power-on)}$

T 155 Pitch control force in manoeuvres

The pitch control forces during turns, or when recovering from manoeuvres, must be such that at constant speed an increase in load factor is associated with an increase in control force. []

Stability

T 171 General

- a) The gyroplane must be able to be flown without undue piloting skill, alertness or strength in any normal manoeuvre for a period of time as long as that expected in normal operation.
- b) There must be no tendency for the gyroplane to rapidly increase the turn rate during a turn with normal accelerations of up to 1.5 g at all allowable power settings.
- c) There must be no tendency for the gyroplane to pitch up during a turn, with normal accelerations of up to 1.5 g, at all allowable power settings.

T 173 Static longitudinal stability

- a) [The longitudinal control must be designed so that a rearward movement of the control is necessary to obtain an airspeed less than the trim speed, and a forward movement of the control is necessary to obtain an airspeed more than the trim speed.
- b) Throughout the full range of altitude for which certification is requested, with the throttle held constant during the manoeuvres specified in T 175 a) through d), the slopes of 1) the control force versus airspeed curve and 2) the control position versus airspeed curve must be positive or neutral (stable).]
- c) Where a variable aircraft pitch trim system is provided for use in flight, the gyroplane shall be trimmed at the datum conditions specified in T 175. Where such a pitch trim system is not provided, the stability characteristics must be assessed by the change of control force with speed compared to the control force at the datum condition. In all cases, the stability characteristics shall be assessed over changes of speed of approximately $\pm 15\%$ from the datum speed.

T 175 Demonstration of static longitudinal stability

The control force versus speed curve must have a [positive or neutral (stable)] slope in the following conditions:

- a) Climb at:
 - 1) the best climb speed, V_Y ; and
 - 2) maximum continuous power.
- b) Cruise at:

- 1) the best climb speed, V_Y , and at the lower of V_{NE} or V_H ; and
 - 2) power for level flight.
- c) Descent at:
- 1) the minimum rate of descent speed (see T 71); and
 - 2) power off.
- d) Approach at:
- 1) the recommended approach speed; and
 - 2) approach power.

T 177 Lateral and directional stability

- a) Following an initial yaw disturbance, with [] controls, [held] fixed [], the gyroplane shall tend to correct automatically for moderate disturbance in yaw. [With the yaw controls free a yaw disturbance or sideslip shall not result in a dangerous condition. (See AMC T 177 a).)]
- b) The directional and lateral stability shall be sufficient to prevent dangerous flight conditions following abrupt pedal displacements.
- c) In a sideslip, any control force must increase progressively with sideslip; the gradient need not be linear but must not reverse. Sufficient cues must accompany sideslip to alert the pilot when approaching sideslip limits.
- d) The characteristics detailed in T 177a) to c) shall be met under the following conditions:
 - 1) In the climb, at maximum continuous power, at V_Y ;
 - 2) In level flight at:
 - i) the best climb speed V_Y ; and
 - ii) the lower of V_{NE} or V_H .
 - 3) At the minimum rate of descent speed (see T 71) with and without the engine operating, and
 - 4) At the recommended approach speed.

T 181 Dynamic stability (See AMC T 181.)

- a) Any oscillations occurring under any permissible flight condition must be damped both with the primary controls fixed and free [for longitudinal and lateral controls but fixed for the yaw control.]
- b) The gyroplane, under smooth air conditions, must exhibit no dangerous behaviour at any speed between the speed for best rate of climb and V_{NE} , when all controls are fixed or free for a period of five seconds.

Ground Handling Characteristics

T 231 Directional stability and control

- a) The gyroplane must have satisfactory ground handling characteristics, including freedom from uncontrolled tendencies in any condition expected in operation, particularly in all take-off conditions.

- b) The ability to take off and land safely in crosswinds shall be investigated. Based on the results of these tests, advice on operation in crosswinds shall be given in the Pilot's Handbook.

T 235 **Taxying condition** (See AMC T 235 a.)

- a) The gyroplane must be safely controllable and manoeuvrable when it is taxied over the roughest ground that may reasonably be expected in normal operation.
- b) The ground speeds up to which it is safe to taxi, take off and touch down must be determined.

T 241 **Ground resonance** (See AMC T 241.)

The gyroplane must have no dangerous tendency to oscillate on the ground with the rotor turning. This must be shown for all intended combinations of rotor speed and gyroplane forward speed on the ground, including use of any rotor spin-up system.

Miscellaneous Flight Requirements

T 251 **Vibration**

Each part of the gyroplane must be free from excessive vibration under each appropriate speed and power condition, throughout the flight envelope at speeds up to V_{DF} .

INTENTIONALLY LEFT BLANK

Sub-Section C Structure

General

T 301 Loads

- a) Strength requirements are specified in terms of limit loads (the maximum loads to be expected in service) and ultimate loads (limit loads multiplied by prescribed factors of safety). Unless otherwise provided, prescribed loads are limit loads.
- b) Unless otherwise provided, the air and ground loads must be placed in equilibrium with inertia loads, considering each major item of mass in the gyroplane. These loads must be distributed so as to represent actual conditions or a conservative approximation to them.
- c) If deflections under load would significantly change the distribution of external or internal loads, this redistribution must be taken into account.

T 303 Factor of safety

Unless otherwise provided, a factor of safety of 1.5 must be used.

T 305 Strength and deformation

- a) The structure and control systems must be able to support limit loads without permanent deformation. At any load up to limit loads, the deformation must not interfere with safe operation.
- b) The structure [and control systems] must be able to support ultimate loads without failure for at least three seconds. However, when proof of strength is shown by dynamic tests simulating actual load conditions, the three second limit does not apply.

T 307 Proof of structure

- a) Compliance with the strength and deformation requirements of T 305 must be shown for each critical load condition. Theoretical structural analysis may be used only if the structure conforms to those for which experience has shown this method to be reliable. In other cases, substantiating load tests must be made. (See AMC T 307 a.)
- b) Certain parts of the structure must be tested as specified in Sub-Section D.

NOTE: Structural standards contained in Sub-Section C do not constitute all the structural requirements necessary to show compliance.

T 309 Design conditions

The following values and limitations must be established and compliance with the structural requirements of this Sub-Section must be shown for all allowable combinations of:

- a) the design maximum weight;
- b) the rotor rpm range;
- c) forward speeds up to V_D ;
- d) the centre of gravity limitations; and
- e) the positive and negative limit manoeuvring load factors.

Flight Loads

T 321 General

- a) Flight load factors represent the ratio of the aerodynamic force component (acting normal to the flight path of the gyroplane) to the weight of the gyroplane. A positive flight load factor is one in which the aerodynamic force acts upward, with respect to the gyroplane.
- b) Compliance with the flight load requirements [of this Sub-Section] must be shown:
 - 1) [at each weight from the design minimum weight to the design maximum weight; and
 - 2) with any practical distribution of loading configurations within the operating limitations in the Pilot's Handbook.]
- c) Aerodynamic data required for the establishment of the load conditions must be verified by tests, calculations or by conservative estimation.

T 337 Limit manoeuvring load factor (See AMC T 337.)

The gyroplane's rotor must be designed for a positive limit manoeuvring load factor of +3.5, at all forward speeds from zero to the Maximum Design Speed V_D .

The rest of the gyroplane must be designed for positive and negative limit manoeuvring load factors of +3.5 and -0.5, respectively, at all forward speeds from zero to the Maximum Design Speed V_D .

T 339 Resultant limit manoeuvring loads

The loads resulting from the application of limit manoeuvring load factors are assumed to act at the centre of the rotor hub and to act in directions so as to represent each critical manoeuvring condition.

T 351 Yawing conditions

The gyroplane must be designed for yawing loads on the vertical tail surface specified in T 413.

T 361 Engine torque

- a) The engine mount and its supporting structure must be designed for the effects of:
 - 1) the limit torque corresponding to take-off power and propeller speed, acting simultaneously with 75% of the limit loads of T 337; and
 - 2) the limit torque corresponding to the maximum continuous power and propeller speed, acting simultaneously with the limit loads of T 337.
- b) For conventional reciprocating engines with positive drive to the propeller, the limit torque to be accounted for in T 361a) and T 547d) is obtained by multiplying the mean torque by the appropriate factor from the following table:

Engine	Two stroke			Four stroke				
	1	2	3 or more	1	2	3	4	5 or more
Factor	6	3	2	8	4	3	2	1.33

NOTE: 'Positive drive' includes direct drive, gear drive or toothed belt; for other drives (e.g. centrifugal clutch) and unconventional engines, the appropriate factor must be agreed with the CAA.

T 363 Side load on engine mount

- a) The engine mount and its supporting structure must be designed for a limit load factor in a lateral direction, for the side load on the engine mount, of not less than one third of the limit load factor of T 337.
- b) The side load prescribed in a) may be assumed to be independent of other flight conditions.

Control Surfaces and System Loads

T 395 Primary control system

- a) The part of each control system from the pilot's controls to the control stops must be designed to withstand pilot forces of not less than the forces specified in T 397.
- b) The part of each control system from the control stops to the attachment to the rotor hub (or control areas) must be designed to at least:
 - 1) withstand the maximum pilot forces obtainable in normal operation; and
 - 2) if operational loads may be exceeded through jamming, ground gusts, control inertia, or friction, support without yielding 0.60 times the limit pilot forces specified in T 397.
 - 3) for yaw control, the load corresponding to the control surface load specified in T 413.

T 397 Limit pilot forces

For primary flight controls. The limit pilot forces are as follows:

- a) For foot controls, 580 N.
- b) For stick controls, 445 N fore and aft, and 300 N laterally.

T 399 Dual control systems

Dual control systems must be designed to withstand the loads that result when each pilot applies 0.75 times the load specified in T 397, with

- a) the pilots acting together in the same direction; and
- b) the pilots acting in opposition.

T 405 Secondary control systems (See AMC T 405.)

Secondary control systems such as those for brakes, trim controls etc. must be designed for supporting the maximum forces that a pilot is likely to apply to those controls.

Stabilizing and Control Surfaces

T 413 Control surface loads

- a) Each stabilizing and control surface (other than the rotor blades), and its supporting structure, must be designed so that limit loads are not less than the greater of:
 - 1) 720 N/m^2 (evenly distributed over the control surface); or
 - 2) the aerodynamic load resulting where the normal force coefficient C_N equals 1.5 at the maximum design speed, $[V_D]$

- b) Compliance with sub-paragraph a) of this paragraph must be shown with realistic or conservative load distributions with allowance for any relative slipstream effects.

Ground Loads

T 471 **General**

The limit ground loads specified in this Sub-Section are considered to be external loads and inertia forces that act upon a gyroplane structure. In each specified landing condition, the external reactions must be placed in equilibrium by the linear and angular inertia forces in a rational or conservative manner.

T 473 **Landing gear – shock absorption** (See AMC T 473.)

- a) It shall be determined that the landing gear is capable of absorbing the energy which would result from the gyroplane being dropped at its maximum permitted take-off weight from a height of at least 0.33 m from the lowest point of the landing gear to the ground without either the shock absorber or tyre bottoming.
- b) Compliance must be established for pitch attitudes representing:
- 1) the level attitude with main and nose or tail wheels (if appropriate) in contact with the ground;
 - 2) the level attitude with main wheels in contact with the ground and nose or tail wheels just clear of the ground; and
 - 3) the tail-down attitude with:
 - i) for nose wheel configurations, the tail structure just clear of the ground; or
 - ii) for tail wheel configurations, the tail wheel in contact with the ground and the main wheels just clear of the ground.
- c) It shall be determined that the nose gear can absorb energy from the front equivalent to 100% of the energy that the nose gear is required to absorb vertically by T 473 b) 2).

T474 **Landing case – strength** (See AMC T 474.)

- a) The selected limit vertical inertia load factor for the airborne landing conditions may not be less than that obtained when landing with a vertical velocity of 2.55 m/sec.
- b) Rotor lift not exceeding two thirds of the weight of the gyroplane may be assumed to act through the centre of gravity. The landing gear reaction factor may be equal to the inertia load factor minus the ratio of the above rotor lift to the gyroplane weight.
- c) In the absence of load factors determined from drop testing, a limit vertical landing gear reaction factor of 3 must be used which may be based on static reactions for all the wheels in contact at touchdown.
- d) The minimum load factor used for design may not be less than 2.67 at maximum weight.

T 479 Level landing conditions

- a) For a level landing the gyroplane is assumed to be in the following flight attitudes:
- 1) For gyroplanes with primary support tail wheels, a normal level flight attitude;
 - 2) For gyroplanes with primary support nose wheels, attitudes in which:
 - i) the nose and main wheels contact the ground simultaneously; and
 - ii) the main wheels contact the ground and the nose wheel just clear of the ground. (See AMC T 479 a) 2).)
- b) P_z max, used in cases 1, 2 and 3 below, is the greatest value of the landing gear reaction derived from the criterion in paragraph T 474 c). The following drag and vertical force (in ground axes) combinations must be considered in the absence of rational analysis:
- 1) Spin up (longitudinal aft):
Vertical = $0.6 P_z$ max and
drag = $0.5 P_z$ max;
 - 2) Spring back (longitudinal forward):
Vertical = $0.8 P_z$ max and
drag = $-0.5 P_z$ max (forward);
 - 3) Maximum vertical reaction:
Vertical = P_z max and
drag = $\pm 0.3 P_z$ max.

T 481 Tail-down landing conditions

- a) For a tail-down landing, the gyroplane is assumed to be in the following attitudes:
- 1) For gyroplanes where the primary elements of the undercarriage comprise main and tail wheels, an attitude in which the main and tail wheels contact the ground simultaneously;
 - 2) For gyroplanes where the primary elements of the undercarriage comprise main and nose wheels, the maximum nose-up attitude that can be achieved as a steady state in the landing configuration or the maximum angle allowing ground clearance by each part of the gyroplane, whichever is less.
- b) The ground reactions are maximum vertical reaction alone, no drag force need be considered.

T 483 One-wheel landing conditions

For the one-wheel landing condition, the gyroplane is assumed to be in the level attitude and to contact the ground on one side of the main landing gear. In this attitude, the ground reactions must be the same as those obtained on that side under T 479 b). The unsymmetrical ground reaction must be reacted by rolling and yawing accelerations.

T 485 Side load condition (See AMC T 485.)

- a) For the side load condition, the gyroplane is assumed to be in the attitude specified in T 479 a) with only the main wheels contacting the ground, and with the shock absorbers and tyres in their static positions.

- b) The vertical limit load factor must be 1.33, with the vertical ground reaction divided equally between the main wheels. No lift is assumed.
- c) The limit side inertia factor must be 0.83, with the side ground reaction divided between the main wheels so that:
 - 1) 0.5 W is acting inboard on one side; and
 - 2) 0.33 W is acting outboard on the other side.

T 493 Braked roll – gyroplanes with braked wheels

The following braked roll conditions apply:

- a) A Limit vertical load factor of 1.33 with the shock absorbers and tyres in their static positions;
- b) The attitudes and ground contacts as for level landings with all wheels on the ground; and
- c) The drag reaction equal to the vertical reaction multiplied by a coefficient of friction of 0.8 applied at the ground contact point of each wheel with brakes, except that it need not exceed the maximum value corresponding to limiting brake torque.

T 499 Supplementary conditions for nose wheels

In determining the ground loads on nose wheels the following conditions must be met, assuming that the shock absorbers and tyres are in their static positions:

- a) For aft acting loads the limit forces at the axle must be:
 - 1) a vertical component of 2.25 times the static load on the wheel; and
 - 2) a drag component of 0.8 times the vertical load.
- b) For forward acting loads the limit forces at the axle must be:
 - 1) a vertical component of 2.25 times the static load on the wheel; and
 - 2) a forward component of 0.4 times the vertical load.
- c) For sideways acting loads the limit forces at the axle must be:
 - 1) a vertical component of 2.25 times the static load on the wheel; and
 - 2) a side component of 0.7 times the vertical load in either direction.

Main Component Requirements

T 547 Rotor structure

- a) Each rotor assembly (including the rotor hubs and blades) must be designed as prescribed in this paragraph.
- b) The rotor structure must be designed to withstand the critical flight loads prescribed in T 337 and T 339.
- c) The rotor structure must be designed to withstand loads simulating for the rotor blades and hubs, the impact force of each blade against its teetering stops during ground operation. (See AMC T 547 c.)
- d) The rotor structure must be designed to withstand the maximum limit torque likely to be transmitted by any rotor spin-up device or rotor brake, at all speeds from zero to the maximum at which the device is designed to be engaged. This limit torque must be distributed to the rotor blades in a rational manner. Account must be taken of the factors prescribed in T 361 b).

T 549 Fuselage, landing gear and rotor pylon structures

- a) Each fuselage, landing gear and rotor pylon structure must be designed as prescribed in this paragraph. Resultant rotor forces may be represented as a single force applied at the rotor hub attachment point.
- b) Each structure must be designed to withstand:
 - 1) the critical loads prescribed in T 337 and T 339.
 - 2) the applicable ground loads prescribed in T 471 and T 473, and
 - 3) the loads prescribed in T 547 c) and d).
- c) Each engine mount and adjacent fuselage structure must be designed to withstand the loads occurring under flight and landing conditions, including powerplant torque and gyroscopic movements. (See AMC T 549 c.)

Emergency Landing Conditions

T 561 General

- a) The gyroplane, although it may be damaged in emergency landing conditions, must be designed as prescribed in this paragraph to protect each occupant under those conditions.
- b) The structure must be designed to give each occupant every reasonable chance of escaping serious injury in a crash landing when proper use is made of belts and harnesses provided for in the design, in the following conditions:
 - 1) Each occupant experiences ultimate inertial forces corresponding to the following load factors:

Direction	Load Factor
Upward	4.5
Forward	9.0
Sideward	3.0
Downward	4.5

- 2) These forces are independent of each other and are relative to the surrounding structure.
- c) The supporting structure must be designed to restrain, under loads up to those specified in sub-paragraph b) of this paragraph, each item of mass that could injure an occupant if it came loose in a minor crash landing.
- d) Where failure of all or part of the engine-mounting structure could result in an engine following a trajectory that could pass through any part of the normal crew accommodation or fuel tanks, the attachment structure must be designed to withstand an ultimate inertia force corresponding to an acceleration of 15 g in that direction. (See AMC T 561 d.)
- e) Fuel tanks, fuel lines, oil tanks and oil lines must be capable of retaining their contents under the inertial forces of b) without rupture.

Fatigue Evaluation

T 571 Fatigue strength

- a) The detail design of the gyroplane shall be such that, as far as reasonably practicable, features that cause high stresses are avoided, unless it can be shown that features of a similar design have accumulated considerable satisfactory service experience in a similar application.
- b) With the exception of the rotor hub spindle, bolts or threaded parts shall not be used in the construction of the rotor hub or blades in any application where they are subject to an alternating tensile stress (unless it can be shown that parts of a similar design, specification and use have had considerable satisfactory service experience).
- c) The rotor hub spindle, together with its associated nuts, washers and bearing surfaces, shall have an ultimate reserve factor in excess of 10.
- d) Materials known to have poor crack propagation properties shall not be used in any part of the primary structure.
- e) All parts of the primary structure shall be easily accessible for inspection.
- f) Flexible paints or coatings shall not be used on the external surfaces of the primary structure.

Other Loads

T 597 Loads from single masses (See AMC T 597.)

The attachment means for all single masses, which are part of the equipment of the gyroplane, including ballast, must be designed to withstand loads corresponding to the maximum design load factors to be expected from the established flight and ground loads, including the emergency landing conditions of T 561.

Sub-Section D Design and Construction

General

T 601 Design

- a) [The gyroplane may have no design features or details that experience has shown to be hazardous or unreliable.]
- b) The [suitability] of any part having an important bearing on safety and which is not amenable to simple analysis must be established by test.

T 603 Materials

The suitability and durability of materials used for parts, the failure of which could adversely affect safety, must:

- a) be established by experience or tests; and
- b) meet specifications that ensure their having the strength and other properties assumed in the design data. (See AMC T 603 b.);
- c) [take into account the effects of environmental conditions such as temperature and humidity, expected in service.]

T 605 Fabrication methods

The methods of fabrication used must produce consistently sound structures which must be reliable with respect to maintaining the original strength under reasonable service conditions. If a fabrication process (such as glueing, spot welding, heat treating, or processing of non-metallic materials) requires close control to reach this objective, the process must be performed under a defined process specification. Unconventional methods of fabrication must be substantiated by adequate tests.

T 607 Locking of connections

- a) A [] means of locking must be provided on all connecting elements in the primary structure and in control and other mechanical systems which are essential to safe operation of the gyroplane.[]
- b) [A non-friction locking device must be used in addition to any self-locking device on connected assemblies subject to rotation in operation. (See AMC T 607).]

T 609 Protection of structure

Each part of the structure must:

- a) be suitably protected against deterioration or loss of strength in service due to any cause, including:
 - 1) weathering;
 - 2) corrosion;
 - 3) abrasion; and
- b) have adequate provisions for ventilation and drainage.

T 611 Inspection

Means must be provided to allow inspection (including inspection of principal static and rotating structural elements and control systems), close examination, repair and replacement of each part requiring periodic inspection, maintenance, adjustments for proper alignment and function, lubrication or servicing.

T 612 Provisions for rigging and derigging

The design must be such that during rigging and de-rigging by persons having no more than average skills, the probability of damage or permanent deformation, especially when this is not readily visible, is extremely remote. Incorrect assembly must be avoided by proper design provisions. It must be possible to inspect the gyroplane easily for correct assembly.

T 613 Material strength properties and design values

- a) Material strength properties must be based on enough tests to establish design values on a statistical basis.
- b) The design values must be chosen so that the probability of any structure being under strength because of material variations is extremely remote. (See AMC T 613 b.)
- c) Where the temperature attained in an essential component or structure in normal operating conditions has a significant effect on strength, that effect must be taken into account. (See AMC T 613 c.)
- d) Where the material used for primary structure may suffer degradation in strength and/or changes in stiffness due to environmental effects in service, due account shall be taken of these characteristics in the design.

T 619 Special factors

- a) The factor of safety prescribed in T 303 must be multiplied by appropriate combinations of the special factors prescribed in T 619 b), T 621 to T 626, T 657 and T 693. (See AMC T 619 a.)
- b) For each part of the structure not covered by T 621 to T 625 but whose strength is:
 - 1) uncertain;
 - 2) likely to deteriorate in service before normal replacement; or
 - 3) subject to appreciable variability because of uncertainties in manufacturing processes or inspection methods;

The special factor must be chosen so that failure of the part due to inadequate strength is improbable. (AMC T 619 b.)

T 621 Casting factors

For castings, the strength of which is substantiated by at least one static test and which are inspected by visual methods, a casting factor of 2.0 must be applied. This factor may be reduced to 1.25 provided that the reduction is substantiated by tests on not less than three sample castings and if these, and all production castings, are subjected to an accepted visual and radiographic inspection or an approved equivalent non-destructive inspection method.

T 623 Bearing factors

- a) The factor of safety for bearing loads at bolted or pinned joints must be multiplied by a special factor of 2.0 to provide for:
 - 1) relative motion in operation; and
 - 2) joints with clearance (free fit) subject to pounding and/or vibration.
- b) For control surface hinges and control system joints, compliance with the factors prescribed in T 657 and T 693, respectively, meets sub-paragraph a) of this paragraph.

T 625 Fitting factors

For each fitting (a part or terminal used to join one structural member to another), the following apply:

- a) For each fitting whose strength is not proven by limit and ultimate load tests in which actual stress conditions are simulated in the fitting and surrounding structures, a fitting factor of at least 1.15 must be applied to each part of:
 - 1) the fitting;
 - 2) the means of attachment; and
 - 3) the bearing on the joined members.
- b) No fitting factor need be used for joint designs based on comprehensive test data (such as continuous joints in metal plating, welded joints, and scarf joints in wood).
- c) For each integral fitting, the part must be treated as a fitting up to the point at which the section properties become typical of the member.
- d) Local attachments in the load path between the safety belt or harness and the main gyroplane structure must be shown by analysis, test, or both, to have at least the strength necessary for 1.33 times the loads corresponding to the emergency alighting inertia loads of T 561.
- e) When using only two hinges at each control surface, the safety factor for these hinges and the attached parts of the primary structure must be multiplied by a factor of 1.5.

T 626 Cable factor (See AMC T 626.)

An ultimate factor of safety of 2.0 on nominal cable strength must be applied to cables used for structural applications and for all primary control systems.

T 629 Flutter prevention and structural stiffness

Each major part of the gyroplane must be free from flutter and resonance under each appropriate speed and power condition, and this must be demonstrated by flight tests at speeds up to V_{DF} .

Control Surfaces and Rotors

T 653 Drainage

- a) For each rotor blade:
 - 1) there must be a means for venting the internal pressure of the blade;
 - 2) drainage holes must be provided for the blade; and
 - 3) the blade must be designed to prevent water from becoming trapped in it.
- b) Sub-paragraphs a) 1) and 2) of this paragraph do not apply to sealed blades capable of withstanding the maximum pressure differentials expected in service.

T 655 Control-surface installations (other than rotor blades)

- a) Movable control surfaces must be installed so that there is no interference between any surfaces or their bracings, when one surface is held in any position and the others are operated through their full angular movement. This requirement must be met:

- 1) under limit load conditions for all control surfaces through their full angular range; and
 - 2) under limit load on the gyroplane structure other than the control surfaces.
- b) If an adjustable stabiliser is used, it must have stops that will limit its range of travel to that allowing safe flight and landing.

T 657 **Control-surface hinges (other than rotor blades)**

- a) Control-surface hinges, except ball and roller bearing hinges, must have a factor of safety of not less than 6.67 with respect to the ultimate bearing strength of the softest material used as a bearing.
- b) For ball-bearing or roller-bearing hinges, the approved rating of the bearing must not be exceeded.
- c) Hinges must have enough strength and rigidity for loads parallel to the hinge line.

T 659 **Mass balance**

- a) The spanwise balance of the rotor blades must be such that excessive vibration is prevented. The method of balancing and the tolerance must be agreed with the CAA.
- b) The chordwise balance of the blades must be at, or forward of, the 25% chord. The chordwise balance of each blade in a pair must be the same, or within a tolerance to be agreed with the CAA.
- c) The supporting structure and the attachment of rotor-blade mass-balance weights must have an ultimate reserve factor in excess of 10 when subjected to the combined loads resulting from:
 - 1) accelerations of ± 20 g in the flap plane of the rotor;
 - 2) accelerations of ± 20 g in the lag plane of the rotor; and
 - 3) the centrifugal force at the maximum rotor speed.
- d) The supporting structure and the attachment of mass-balance weights used on control surfaces (other than rotor blades) must be designed for:
 - 1) 24 g normal to the plane of the control surface;
 - 2) 12 g fore and aft; and
 - 3) 12 g parallel to the hinge line.

T 661 **Rotor-blade clearance** (See AMC T 661.)

There must be enough clearance between the rotor blades and other parts of the structure to prevent the blades from striking any part of the structure, or passing through any area likely to cause injury to occupants during any permitted operating condition.

T 665 **Rotor hub bearings**

All rotor-hub bearings must have their suitability established by experience or tests.

Control Systems

T 671 **General**

Each control must operate easily, smoothly and positively enough to allow proper performance of its functions.

T 675 Stops

- a) Each control system must have stops that positively limit the range of motion of the pilot's controls.
- b) Each stop must be located so that wear, slackness, or take-up adjustments will not adversely effect the control characteristics of the gyroplane because of a change in the range of travel of the control.
- c) Each stop must be able to withstand any loads corresponding to the design conditions for the control system.

T 677 Trim system

If a trim system is fitted which is operable in flight, proper precautions must be taken to prevent inadvertent, improper, or abrupt trim operation.

- a) There must be means near the trim control to indicate to the pilot (when strapped in), the direction of trim control movement relative to the gyroplane.
- b) There must be some means to indicate to the pilot the position of the trim device, with respect to the range of adjustment. This means must be visible to the pilot (when strapped in) and must be located and designed to prevent confusion.

T 679 Control system locks

If there is a device to lock the control system [with the gyroplane] on the ground, there must be a means to:

- a) give unmistakable warning to the pilot when the lock is engaged; and
- b) prevent the lock from engaging in flight.

T 683 Operation tests

It must be shown by functional tests that the system designed to the loads specified in T 397 is free from:

- a) jamming;
- b) excessive friction; and
- c) excessive deformation;

when operating the controls from the cockpit.

T 685 Control system details

- a) Each detail of each control system must be designed and installed to prevent jamming, chafing and interference from baggage, passengers, loose objects, or the freezing of moisture.
- b) There must be means in the cockpit to prevent the entry of foreign objects into places where they would jam the system. (See AMC T 685 b.)
- c) There must be means to prevent the slapping of cables, tubes, or rods against other parts.
- d) Each element of the flight control system must have design features, or must be distinctively and permanently marked, to minimise the possibility of incorrect assembly that could result in malfunctioning of the control system.

T 687 Spring devices

The reliability of any spring device used in the control system must be established by tests simulating service conditions unless failure of the spring will not cause flutter or unsafe flight characteristics.

T 689 Cable systems

- a) Each cable, cable fitting, turnbuckle, splice, and pulley used must meet stated specifications. In addition:
 - 1) No cable smaller than 2 mm diameter may be used in primary control systems;
 - 2) Each cable system must be designed so that there will be no hazardous change in cable tension throughout the range of travel under operating conditions and temperature variations; and
 - 3) There must be means for visual inspection at each fairlead, pulley, terminal and turnbuckle.
- b) Each kind and size of pulley must correspond to the cable with which it is used. Each pulley must have closely fitted guards to prevent the cables from being misplaced or fouled, even when slack. Each pulley must lie in the plane passing through the cable so that the cable does not rub against the pulley flange. (See AMC T 689 b.)
- c) Fairleads must be installed so that they do not cause a change in cable direction of more than 3°, except where tests or experience indicate that a higher value would be satisfactory. The radius of curvature of fairleads must not be smaller than the radius of a pulley for the same cable.
- d) Turnbuckles must be attached to parts having angular motion in a manner that will positively prevent binding throughout the range of travel.

T 693 Joints

Control system joints (in push-pull systems) that are subject to angular motion, except those in ball- and roller-bearing systems, must have a special factor of safety of not less than 3.33 with respect to the ultimate bearing strength of the softest material used as a bearing. This factor may be reduced to 2.0 for joints in cable-control systems. For ball- or roller-bearings, the approved ratings must not be exceeded.

Cockpit Design

T 771 General

The cockpit and its equipment must allow each pilot to perform his duties without unreasonable concentration or fatigue.

T 773 Cockpit view

Each cockpit must be designed so that:

- a) the pilot's field of view is sufficiently extensive, clear and undistorted for safe operation. (See AMC T 773 a.);
- b) if a windscreen is provided, rain does not unduly impair his view along the flight path in normal flight and during landing. (See AMC T 773 b.);
- c) the pilot is easily able to establish a pitch attitude by reference to a fixed point of the airframe, when looking forward. (See AMC T 773 c.)

T 775 Windshields and windows

Windshields and windows, if fitted, must be constructed of a material that will not break into dangerous fragments or become opaque when damaged.

T 777 Cockpit controls

- a) Each cockpit control must be located to provide convenient operation, and to prevent confusion and inadvertent operation.
- b) The controls must be located and arranged so that each pilot, when properly secured by his safety harness, has full and unrestricted movement of each control. (See AMC T 777 b.)
- c) In gyroplanes with dual controls, it must be possible to operate all essential controls from each of the two pilots seats.
- d) Secondary controls must maintain any desired position without requiring constant attention by the pilot(s), and must not tend to creep under loads or vibration. Controls must have adequate strength to withstand operating loads without failure or excessive deflection.

T 779 Motion and effect of cockpit controls

Cockpit controls must be designed so that they operate as follows:

Controls	Motion and effect
Roll	Right (clockwise) for "right wing" down
Pitch	Rearward for nose up
Yaw	Right pedal forward for nose right
Trim	Corresponding to sense of motion and axis of the controls (See AMC T 779.)
Throttle control	Forward, or clockwise, to increase power (See AMC T 779.)
Propeller pitch	Forward to decrease pitch and/or increase rpm
Mixture	Forward, or up, for rich
Switches	Down for off

T 780 Colour markings of cockpit controls

Emergency controls must be coloured red.

T 783 [Doors

- a) There must be a provision to secure each door.
- b) There must be a means to safeguard each door against inadvertently opening in flight unless:
 - 1) it can be shown that any door that is not closed and secured would be clearly evident to the crew from their normal operating position(s) before flight; or
 - 2) a door opening in flight does not adversely affect the safe operation of the aircraft or cause undue distraction to the pilot.】

T 785 Seats and safety harnesses

- a) Each seat and its supporting structure must be designed for the placarded occupant weight of T 1557 d) 1) iii) and must not be lower than that specified by T 25 b) and for the maximum load factors corresponding to the specified flight and ground conditions, including the emergency landing condition prescribed in T 561 b).
- b) Seats, including cushions, must not deform under flight loads to such an extent that the pilot is unable to reach the controls safely, or that the wrong controls are operated.

- c) The strength of the safety harness must not be less than that following from the ultimate loads for the flight- and ground-load conditions and for the emergency landing conditions according to T 561 b), taking into account the geometry of the harness and seat arrangement. (See AMC T 785 c).)
- d) Each safety harness must be attached so that the wearer is safely retained in the initial sitting position under flight and emergency landing accelerations. (See AMC T 785 d).)

T 786 **Protection from injury**

- a) Each seat and its supporting structure must be so designed that in the event of a collapse of any or all of the landing gear units, the risk of serious injury to the occupant is minimised. (See AMC T 786 a).)
- b) Rigid structural members, or rigidly mounted items of equipment, must be padded where necessary to protect the occupant(s) from injury during minor crash conditions.

T 787 **Baggage compartment**

- a) Each baggage compartment must be designed for its placarded maximum weight of contents and for the critical load distributions at the appropriate maximum load factors corresponding to the flight- and ground-load conditions of this Section.
- b) Means must be provided to protect occupants from injuries by movement of the contents of the baggage compartments when subjected to ultimate inertia forces corresponding to the accelerations prescribed in T 561 b).

T 807 **Emergency exit**

- a) The cockpit must be so designed as to provide occupants with unimpeded and rapid escape in an emergency.
- b) Where the cockpit is enclosed, the opening system must be designed for simple and easy operation. It must function rapidly and be designed so that it can be operated by each occupant strapped in his/her seat and also from outside the cockpit. [There must be reasonable provision to prevent jamming by fuselage deformation.]

T 831 **Ventilation**

- a) When there is an enclosed cockpit it must be designed so as to afford suitable ventilation under normal flying conditions.
- b) Carbon monoxide concentration must not exceed one part per 20,000 parts air.

T 859 **[Heating Systems**

- a) **General.** For each heating system that involves the passage of cabin air over, or close to, the exhaust manifold, there must be means to prevent carbon monoxide from entering any cabin or pilot compartment.
- b) **Heat exchangers.** Each heat exchanger must be:
 - 1) of suitable materials;
 - 2) adequately cooled under all conditions; and
 - 3) easily disassembled for inspection.
- c) **Heater control.** There must be means to prevent the hazardous accumulation of water or ice on, or in any heater control component, control system tubing, or safety control.]

- d) [Each ventilating air intake must be located so that no flammable fluids or vapours or other hazardous gases can enter the heater system:
- 1) during normal operation; or
 - 2) as a result of the malfunction of any other components.]

INTENTIONALLY LEFT BLANK

Sub-Section E Powerplant

General

T 901 Installation

- a) Powerplant installation includes the engine, propeller and each component that:
 - 1) is necessary for propulsion; or
 - 2) affects the safety of the propulsion unit between normal inspections and overhauls; or
 - 3) affects the control of the propulsion unit.
- b) The powerplant must be constructed, arranged and installed to:
 - 1) ensure safe operation between normal inspection and overhaul; and
 - 2) be accessible for necessary inspections and maintenance.
- c) Electrical continuity must be provided to prevent the existence of differences of potential between components of the powerplant, including fuel tanks and other parts of the gyroplane which are electrically conductive.

T 903 Compatibility (See AMC T 903.)

The applicant must show that each combination of engine, [exhaust system] and propeller in a gyroplane, for which a Permit to Fly is sought, is compatible with the gyroplane, functions in a satisfactory manner and can be operated safely within any limitations established under T 1505 and T 1521.

T 917 Rotor spin-up and brake systems

- a) If a rotor spin-up or brake system is installed, it must be designed to prevent:
 - 1) it remaining engaged on take-off;
 - 2) it becoming engaged in flight.
- b) Limitations on the use of any rotor spin-up or brake systems must be specified.

T 923 Flight endurance test (See AMC T 923.)

- a) It shall be confirmed by flight tests that the proposed powerplant and rotor system operating limitations are compatible with the satisfactory functioning of the system, over the proposed range of operating conditions and flight envelope.
- b) The applicant shall conduct a 25-hour flight endurance test on a gyroplane of the type for which a Permit to Fly is sought. The gyroplane must not exhibit any significant problems or failures during the endurance test. This endurance test must be conducted to a flight schedule, which is representative of operational use and agreed in advance with the CAA.
- c) For new designs of rotor system the applicant shall conduct an endurance test on a suitable test vehicle, to an agreed test schedule. (See AMC T 923 c.)

T 925 Propeller clearance

[] Propeller clearances at maximum weight, with the most adverse c.g., with the propeller in the most adverse pitch position and taking account of likely airframe flexibility, must not be less than the following:

- a) **Ground clearance.** There must be adequate ground clearance between the propeller and the ground, with the landing gear statically deflected and in the level normal, take-off, landing or taxiing attitude, whichever is most critical (see AMC T 925 a)). In addition, there must be positive clearance between the propeller and the ground in the level take-off attitude, with:
 - 1) the critical tyre completely deflated and the corresponding landing gear strut statically deflected; and
 - 2) the critical landing gear strut bottomed and the corresponding tyre statically deflected.
- b) **Clearance from other parts of the gyroplane.** There must be positive clearance between all rotating parts of the propeller and spinner and other parts of the gyroplane under all operating conditions with due allowance for airframe and propeller flexibility. (See AMC T 925 b).)
- c) **Clearance from occupant(s).** There must be adequate clearance between the occupant(s) and the propeller(s) so that it is not possible for the occupant(s), when seated and strapped in, to contact the propeller(s) inadvertently. It must be possible for either occupant to enter and leave the gyroplane on the ground without passing dangerously close to the propeller disc. (See AMC T 925 c).)

Fuel System

T 951 General

- a) Each fuel system must be constructed and arranged to ensure a flow of fuel at a rate and pressure established for proper engine functioning under any normal operating condition.
- b) Each fuel system must be arranged so that no fuel pump can draw fuel from more than one tank at a time. Gravity feed systems may not supply fuel to the engine from more than one tank at a time, unless the air spaces are interconnected in a manner to ensure that all interconnected tanks feed equally.
- c) The fuel system must be arranged to minimise the occurrence of vapour locks and to prevent introducing air into the system.

T 955 Fuel flow (See AMC T 955.)

- a) **[General.** The ability of the fuel system to provide fuel at the rates specified in this paragraph and at a pressure sufficient for proper carburettor or fuel injector operation must be shown in the attitude that is most critical with respect to fuel feed and quantity of unusable fuel. These conditions may be simulated in a mock-up. In addition:
 - 1) the quantity of fuel in the tank may not exceed the amount established as the unusable fuel supply for that tank under T 959 plus that necessary to show compliance with this paragraph; and
 - 2) if there is a fuel flowmeter, it must be blocked during the flow test and the fuel must flow through the meter bypass.]
- b) **Gravity systems.** The fuel flow rate for each gravity system (main and reserved supply) must be at least 150% of the maximum fuel consumption of the engine.
- c) **Pump systems.** The fuel flow rate for each pump system (main and reserve supply) must be at least 125% of the maximum fuel consumption of the engine.

- d) **[Multiple fuel tanks.** If the engine can be supplied with fuel from more than one tank, it must be possible, in level flight, to regain full power and fuel pressure to that engine not more than 10 seconds after switching to any full tank after engine malfunctioning due to fuel depletion becomes apparent while the engine is being supplied from any other tank.]

T 959 **Unusable fuel**

The unusable fuel quantity for each tank must be established as not less than that quantity at which the first evidence of malfunctioning occurs under the most adverse fuel-feed conditions occurring [under each intended operation and flight manoeuvre] involving that tank. It shall not be greater than 5% of the tank's capacity. [Fuel system component failures need not be considered.

T 961 **Fuel system hot weather operation**

Each fuel system must be free from vapour lock when using fuel at a temperature of 43°C under critical operating conditions, and with the most critical fuel for which certification is requested.]

T 963 **Fuel tanks: General**

- a) Each fuel tank must be able to withstand without failure, the vibration, inertia, fluid and structural loads to which it may be subjected in normal operation.
- b) Where surging of fuel within the tank could cause significant changes in the centre of gravity of the gyroplane, means must be provided to reduce the surging to within acceptable limits.

T 965 **Fuel tank test**

Each fuel tank must be able to withstand a pressure of 0.1 bar (1½ psi) without failure or leakage.

T 967 **Fuel tank installation**

- a) Each fuel tank must be supported so that the loads resulting from the weight of the fuel are not concentrated. In addition:
- 1) There must be pads, if necessary, to prevent chafing between each tank and its supports; and
 - 2) Materials employed for supporting the tank or padding the supporting members must be non-absorbent or treated to prevent the absorption of fuel.
- b) Each compartment containing a fuel tank must be ventilated and drained to prevent accumulation of flammable fluids and vapours. Each compartment adjacent to a tank must be treated in a similar manner.
- c) No fuel tank may be located where an engine fire could impinge on it. [No part of the engine nacelle skin that lies immediately behind a major air opening from the engine compartment may act as the wall of an integral tank.] (See AMC T 967 c.)
- d) [If a fuel tank is installed in the personnel compartment it must be isolated by fume and fuel-proof enclosures that are drained and vented to the exterior of the gyroplane. A bladder type fuel cell, if used, must have a retaining shell at least equivalent to a metal fuel tank in structural integrity.]
- e) It must be demonstrated that the presence of the tank will in no way interfere with the operation of any part of the gyroplane, or the normal movement of the occupants.

- f) [Each fuel tank located in an enclosed compartment must be separated from the engine compartment by a firewall. At least one-half inch (12.7mm) of clear airspace must be provided between the tank and the firewall.]
- g) Structural damage which may result from a heavy landing in excess of the ultimate capability of the landing gear, but within the emergency landing conditions of T 561, must not result in rupture of the fuel tank or fuel lines.

T969 Fuel tank expansion space

Each fuel tank must have an expansion space of not less than two percent of the tank capacity, unless the tank vent discharges clear of the gyroplane (in which case no expansion space is required). It must be impossible to fill the expansion space inadvertently with the gyroplane in the normal refuelling ground attitudes.]

T 971 Fuel tank sump

- a) Each fuel tank must have a drainable sump which is effective in all normal ground and flight attitudes and with a capacity of 0.10% of the tank capacity, or 120 ml, whichever is the greater. Alternatively:
 - 1) A fuel system sediment bowl or chamber that is accessible for drainage and has a capacity of 25 ml must be fitted, and see also T 951.
 - 2) Each fuel tank outlet must be located so that, in the normal ground attitude, water will drain from all parts of the tank to the sediment bowl or chamber; and
 - 3) Each fuel tank outlet must be designed and located so that no part of the contents of the sump can enter the fuel feed line to the engine.
- b) The drainage system must be readily accessible and easy to drain.
- c) Each fuel system drain must have manual or automatic means for positive locking in the closed position.

T 973 Fuel tank filler connection

- a) [For enclosed cockpit gyroplanes] fuel tank filler connections must be located outside the cockpit. Spilled fuel must be prevented from entering the fuel tank compartment or any part of the gyroplane other than the tank itself. [For gyroplanes with permanent open cockpits, with the fuel filler connection inside the cockpit, adequate fuel drainage away from the cockpit and fuel tank compartment must be provided.
- b) Each filler cap must provide a fuel-tight seal for the main filler opening. However, there may be small openings in the cap for venting purposes or for the purpose of allowing passage of a fuel gauge through the cap.
- c) Each tank filler cap must be designed to minimize the probability of incorrect installation or in-flight loss.]

T 975 Fuel tank vents

Each fuel tank must be vented from the top of the tank. In addition:

- a) Each vent outlet must be located and constructed in a manner that minimises the possibility of its being obstructed by ice or other foreign matter;
- b) Each vent must be constructed to prevent siphoning of fuel during normal operation, nor should it create a partial vacuum;
- c) Each vent must discharge clear of the gyroplane; and
- d) Each vent must discharge away from ignition or exhaust components.

T 977 Fuel filter and strainer

- a) There must be means to protect the engine from the likelihood of stoppage resulting from blockage of the fuel supply and from damage caused by debris in the fuel supply.
- b) There must be a strainer at the outlet to each tank. This strainer must have at least 6 meshes per cm (15 meshes per inch) and must be of such proportions that blockage of the fuel supply by objects entering the tank will be extremely unlikely.
- c) Each filter and each strainer must be easily accessible for drainage or cleaning.
- d) Non-metallic filter elements must be shown to be compatible with the type of fuel specified by the manufacturer. (See AMC T 977 d.)

T 993 Fuel system lines and fittings

- a) Each fuel line must be installed and supported to prevent excessive vibration and to withstand loads due to fuel pressure and accelerated flight conditions. (See AMC T 993 a.)
- b) Each fuel line connected to components, between which relative motion could exist, must have provisions for flexibility.
- c) Each flexible hose must be shown to be suitable for the particular application.
- d) Each fuel line and fitting in any area subject to engine fire conditions must be at least fire resistant.
- e) Leakage from any fuel line or connection must not impinge on hot surfaces or equipment which could cause a fire, nor fall directly onto any occupant.
- f) Fuel line runs must be kept apart from electrical cables.

T 995 Fuel valves and controls

- a) For gyroplanes with cowled engine installations, there must be a positive quick acting valve to shut off fuel to the engine compartment.
- b) The portion of the line between the shut off valve and the engine compartment must be as short as possible.
- c) The shut off means must be guarded against inadvertent operation and be within easy reach of crew members.

Oil System

T 1011 General

- a) If an engine is provided with an oil system, it must be capable of supplying the engine with an appropriate quantity of oil at a temperature not exceeding the maximum established as safe for continuous operation.
- b) Each oil system must have a usable capacity adequate for the endurance of the gyroplane.
- c) [If an engine has an automatic oil injection system, there must be means to notify the pilot when oil is low. If oil is premixed, engine operating instructions must be followed. (See AMC T 1011 c).]

T 1013 Oil tanks

- a) Each oil tank must be installed to:
 - 1) meet the requirements of T 967 a), b) and d); and
 - 2) withstand any vibration, inertia and fluid loads expected in normal operation. Compliance with this requirement may be shown by satisfactory completion of the endurance test of T 923.
- b) The oil level must be easy to check without having to remove any cowling parts (with the exception of oil tank access covers) or to use any tools.
- c) If the oil tank is installed in the engine compartment, it must be made of fireproof material.

T 1015 Oil tank test

Each oil tank must be able to withstand a pressure of 0.33 bar (5 psi) without failure or leakage.

T 1017 Oil lines and fittings

- a) Oil lines must comply with T 993 and must accommodate a flow of oil at a rate and pressure adequate for proper engine functioning, under any normal operating conditions.
- b) Each oil line and fitting must be made of fire-resistant material.
- c) Breather lines must be arranged so that:
 - 1) condensed water vapour or oil that might freeze and obstruct the line cannot accumulate at any point;
 - 2) the breather discharge will not constitute a fire hazard if foaming occurs, or cause emitted oil to strike the occupant(s) or the pilot's windshields;
 - 3) the breather does not discharge into the engine air induction system.

T 1023 [Oil radiators

Each oil radiator and its supporting structures must be able to withstand the vibration, inertia and oil pressure loads to which it would be subjected in operation.]

Cooling

T 1041 General

The powerplant cooling provisions must be able to maintain the temperatures of powerplant components and engine fluids within the temperature limit specified by the engine constructor, or as have been determined to be necessary by the gyroplane constructor, during all likely operating conditions.

Induction System

T 1091 Air induction (See AMC T 1091.)

The air induction system for the engine must supply the air required by the engine under all likely operating conditions.

T 1093 [Induction system icing protection

The engine air induction system shall incorporate means for the prevention and elimination of ice accumulations unless it is demonstrated that this can be accomplished by other means.]

Exhaust System

T 1121 General

- a) The exhaust system must ensure safe disposal of exhaust gases without fire hazard or carbon monoxide contamination in the cockpit.
- b) Each exhaust system part with a surface hot enough to ignite flammable fluids or vapours must be located or shielded so that leakage from any system carrying flammable fluids or vapours will not result in a fire caused by impingement of the fluids or vapours on any part of the exhaust system, including shields for the exhaust system.
- c) Each exhaust system component must be separated by fireproof shields from adjacent flammable parts of the gyroplane.
- d) No exhaust gases may discharge dangerously near any oil- or fuel-system drain.
- e) Each exhaust system component must be ventilated to prevent points of excessively high temperature.
- f) [Each exhaust system must incorporate means designed to minimise blockage of the exhaust exit after any internal failure.]

T 1125 Exhaust manifold

- a) The exhaust system must be fireproof and must have means to prevent failure due to expansion by operating temperature.
- b) The exhaust and silencing system must be supported to withstand the vibration and inertia loads to which it may be subjected in normal operation.
- c) If the design of the exhaust system is such that, after a failure in the exhaust system, it can interfere with the propeller, additional restraint must be provided to ensure a degree of redundancy in the exhaust mounting.
- d) Parts of the exhaust system connected to components between which relative motion could exist must have means for flexibility.

Powerplant Controls and Accessories

T 1141 General

- a) [Each control must be able to maintain any necessary position without:
 - 1) constant attention by the pilot; or
 - 2) tendency to creep due to control loads or vibration.]
 - b) The portion of each powerplant control located in an engine compartment that is required to be operated in the event of fire must be at least fire resistant.
 - c) All controls for starting the engine (and stopping the engine in both normal and emergency conditions) must be easily accessible from one position so as to minimise the risk of an aircraft 'running away'.

T 1145 Ignition switches

- a) A switch must be provided to enable each ignition circuit to be rendered inoperative. (See AMC T 1145 a.)
- b) Each ignition circuit must be independently switched, and must not require the operation of any other switch for it to be made operative.

- c) Ignition switches must be arranged and designed to prevent inadvertent operation.
- d) The ignition switch must not be used as the master switch for other circuits.

T 1149 Propeller speed

- a) Propeller speed [and pitch] must be limited to [] values that ensure safe operation under normal operating conditions.
- b) During take-off and climb at the recommended best-rate-of-climb speed, the propeller must limit the engine rotational speed at full throttle to a value not greater than the maximum allowable rotational speed.
- c) During a descent at V_{NE} with throttle closed or the engine inoperative, the propeller must not permit a rotational speed to be achieved that is greater than 110% of the maximum allowable rotational speed of the engine or propeller, whichever is the lower.

T 1165 Engine ignition systems

Each battery ignition system must be supplemented by a generator that is automatically available as an alternative source of electrical energy to allow continued engine operation if any battery becomes depleted.

T 1187 [Ventilation] (See AMC T 1187)

Each compartment containing any part of the powerplant installation must have provision for ventilation.]

T 1191 Firewalls

- a) Cowled engine installations must be isolated from the rest of the gyroplane by a firewall or shroud.
- b) The firewall or shroud must be constructed so that no hazardous quantity of liquid, gas or flame can pass from the engine compartment to other parts of the gyroplane.
- c) Each opening in the firewall or shroud must be sealed with close fitting, fire resistant grommets, bushings, or firewall fittings.
- d) The firewall and shroud must be fire resistant and protected against corrosion.

T 1193 Cowling and nacelle

When an engine installation is cowled:

- a) each cowling must be constructed and supported so that it can resist any vibration, inertia and air loads to which it may be subjected in operation;
- b) there must be a means for rapid and complete drainage of each part of the cowling in the normal ground and flight attitudes. No drain may discharge where it will cause a fire hazard;
- c) the cowling must be at least fire resistant;
- d) each part behind an opening in the engine compartment cowling must be at least fire resistant for a distance of at least 600 mm aft of the opening; and
- e) each part of the cowling subjected to high temperatures due to its nearness to exhaust system ports or exhaust gas impingement, must be fireproof.

T1194 **[Other surfaces**

Components, lines, and fittings located behind the engine compartment firewall must be constructed of such materials and located at such distances from the firewall that they will not suffer damage sufficient to endanger the gyroplane if that portion of the engine side of the firewall is subjected to a flame temperature of not less than 1100°C for 5 minutes.

T 1195 **Fire detection systems**

Each gyroplane with a fully enclosed rear engine compartment, must have a means to detect fire in the engine compartment in flight.】

INTENTIONALLY LEFT BLANK

Sub-Section F Equipment

General

T 1301 **Function and installation**

- a) Each item of required equipment must:
 - 1) be of a kind and design appropriate to its intended function;
 - 2) be installed according to limitations specified for that equipment; []
 - 3) [be labeled as to its identification, function, or operating limitations, or any applicable combination of these factors; and]
 - 4) function properly when installed. (See AMC T 1301 a) [iv]).
- b) Instruments and other equipment must not in themselves, or by their effect upon the gyroplane, constitute a hazard to safe operation.

T 1303 **Flight and navigation instruments**

The following equipment must be installed:

- a) An air speed indicator;
- b) An altimeter;
- c) A magnetic compass;
- d) A slip indicator;
- e) A tachometer to provide an indication of main rotor rpm movement. The tachometer must be marked or placarded with the maximum and minimum rotor rpm established in accordance with T 33. (See AMC T 1303 e).)

T 1305 **Powerplant instruments**

The following are the required powerplant instruments:

- a) Such pressure, temperature and rpm indications [and/or warnings] as the engine manufacturer may [specify] or as are necessary to operate the engine [and supercharger/turbocharger] within its limitations;
- b) A fuel quantity indicator for each fuel tank, visible by each pilot when strapped in; and
- c) A quantity indicator for each oil tank, e.g. dipstick.
- d) [A manifold pressure indicator for an engine equipped with a variable pitch propeller, where manifold pressure and rotational speed are independently controllable.]

T 1307 **Miscellaneous equipment** (See AMC T 1307.)

- a) A [four - or five - point] safety harness must be available to each occupant, capable of restraining the wearer against the forces resulting from the accelerations prescribed for emergency landing conditions in T 561.
- b) It must not be possible for an unsecured safety harness to contact the propeller or rotor or any other rotating parts.

Instruments: Installation

T 1321 Arrangement and visibility

- a) [Each] flight, navigation [] and powerplant instrument required by T 1305, must be clearly arranged and plainly visible to each pilot.
- b) [Instrument panel vibration must not damage or impair the readability or accuracy of any instrument.
- c) If a visual indicator is provided to indicate malfunction of an instrument, it must be effective under all probable cockpit lighting conditions.

T 1322 Warning, caution and advisory lights

If warning, caution or advisory lights are installed in the cockpit, they must be:

- a) red for warning lights (lights indicating a hazard which may require immediate corrective action);
- b) amber for caution lights (lights indicating the possible need for future corrective action);
- c) green for safe operation lights; and
- d) any other colour, including white, for lights not described in sub-paragraphs a) to c) of this paragraph, provided the colour differs sufficiently from the colours prescribed in sub-paragraphs a) to c) of this paragraph, to avoid possible confusion.]

T 1323 Airspeed indicating system

- a) The airspeed indicating system must be calibrated.
- b) Calibration must be made in flight.
- c) The airspeed indicating system must be suitable for speeds between $0.8 V_{\gamma}$ and at least $1.05 V_{NE}$.

T 1325 Pitot and static pressure systems

- a) Each instrument provided with static pressure case connections must be so vented that the influence of moisture or other foreign matter, speed, and the opening and closing of windows, will not significantly affect the accuracy of the instruments.
- b) The design and installation of pitot and static pressure systems must be such that:
 - 1) positive drainage of moisture is provided;
 - 2) chafing of the tubing, and excessive distortion or restriction at bends in the tubing, is avoided; and
 - 3) the materials used are durable, suitable for the purpose intended, and protected against corrosion.

T 1337 Powerplant instruments

- a) Instruments and instrument lines.
 - 1) Each powerplant instrument line carrying flammable fluids under pressure must meet the requirements of T 993.
 - 2) Each line carrying flammable fluids under pressure must:
 - i) have restricting orifices, or other safety devices, at the source of pressure to prevent the escape of excessive fluid if the line fails;

- ii) [be installed and located so that the escape of fluids would not create a hazard.
- 3) Each powerplant instrument that utilises flammable fluids must be installed and located so that the escape of fluid would not create a hazard.]
- b) [Fuel quantity indicator.] Each exposed sight gauge used as a liquid quantity indicator must be protected against damage. The low-level indication range of the indicator must be plainly visible to the pilot [during flight].

Electrical Systems and Equipment

T 1351 [General

Electrical system capacity

Each electrical system must be adequate for the intended use. In addition:

- a) Electrical power sources, their transmission cables and the associated control and protective devices, must be able to furnish the required power at the proper voltage to each load circuit essential for safe operation; and
- b) Compliance with sub-paragraph a) of this paragraph must be shown by an electrical load analysis, or by electrical measurements, that account for the electrical loads applied to the electrical system in probable combinations and for probable durations;
- c) There must be a means to indicate to the pilot that the electrical power supplies are adequate for safe operation.]

T 1353 Storage battery design and installation

- a) Each storage battery must be designed and installed as prescribed in this paragraph.
- b) [Safe cell temperatures and pressures must be maintained during any probable charging and discharging condition. No uncontrolled increase in cell temperature may result when the battery is recharged (after complete discharge):
 - 1) at maximum regulated voltage or power;
 - 2) during a flight of maximum duration; and
 - 3) under the most adverse cooling condition likely to occur in service.
- c) Compliance with sub-paragraph b) of this paragraph must be shown by tests unless experience with similar batteries and installations has shown that maintaining safe cell temperatures and pressures presents no problem.]
- d) No explosive or toxic gases emitted by any battery in normal operation, or as the result of any probable malfunction in the charging system or battery installation, may accumulate in hazardous quantities within the gyroplane.
- e) No corrosive fluids or gases that may escape from the battery may damage surrounding structures or adjacent essential equipment.
- f) [Each nickel cadmium battery installation capable of being used to start an engine unit must have provisions to prevent any hazardous effect on structure or essential systems that may be caused by the maximum amount of heat the battery can generate during a short circuit of the battery or of its individual cells.
- g) Nickel cadmium battery installations capable of being used to start an engine must have:]

- 1) [a system to control the charging rate of the battery automatically so as to prevent battery overheating;
- 2) a battery temperature sensing and over-temperature warning system with a means for disconnecting the battery from its charging source in the event of an over-temperature condition; or
- 3) a battery failure sensing and warning system with a means for disconnecting the battery from its charging source in the event of battery failure.

T 1357 Circuit protective devices

- a) Protective devices, such as fuses or circuit breakers, must be installed in all electrical circuits other than:
 - 1) the main circuit for starter motors; and
 - 2) circuits in which no hazard is presented by omission.
- b) A protective device for a circuit essential to flight safety must not be used to protect any other circuit.
- c) Each resettable circuit protective device ('trip free' device in which the tripping device cannot be overridden by the operating control) must be designed so that:
 - 1) a manual operation is required to restore service after tripping; and
 - 2) if an overload or circuit fault exists, the device will open the circuit regardless of the position of the operating control.
- d) If the ability to reset a circuit breaker or replace a fuse is essential to safety in flight then:
 - 1) If fuses are used, there must be one spare for each rating, or 50% spare fuses of each rating, whichever is greater;
 - 2) A circuit breaker or fuse must be so located and identified that it can be readily reset or replaced in flight.

T 1361 Master switch arrangement

- a) There must be a master switch or switches arranged to allow ready disconnection of all electrical power sources. The point of disconnection must be adjacent to the sources controlled by the switch. (See AMC T 1361 a)).
- b) The master switch arrangement must be so installed that it is easily discernible and accessible to the pilot in flight.]

T 1365 Electric cables and equipment

- a) Each electric connecting cable must be of adequate capacity and correctly routed, attached and connected so as to minimise the probability of short circuits and fire hazards.
- b) Overload protection must be provided for each electrical circuit. No protective device may protect more than one circuit essential to flight safety.
- c) [For enclosed cockpit gyroplanes, each cable and associated equipment that would overheat in the event of circuit overload or fault must be at least flame resistant and must not emit dangerous quantities of toxic fumes.]

T 1385 External lights

If external lights are installed they must meet the requirements of the Air Navigation Order (ANO).

[Safety Equipment

T 1411 General

- a) When safety equipment is installed it must be readily accessible.
- b) Stowage provisions for that equipment must be furnished and must protect the safety equipment from damage caused by being subjected to the inertia loads specified in T 597.]

Miscellaneous Equipment

T 1431 Airborne radio and radio navigation equipment

Each item of airborne radio equipment provided must comply with the following:

- a) The equipment and its aerials may neither in themselves, nor by their mode of operation or by their effect upon the operating characteristics of the gyroplane and its equipment, constitute a hazard to safe operation. [(See AMC T 1431 a)].
- b) The equipment and its control and monitoring devices must be arranged so as to be easily controllable. Their installation must be such that they are sufficiently ventilated to prevent overheating.
- c) All fixed-installation airborne radio equipment must be approved by the CAA.

INTENTIONALLY LEFT BLANK

Sub-Section G Operating Limitations and Information

General

T 1501 **Operating limitations**

- a) Each operating limitation specified in T 1521 and other limitations and information necessary for safe operation must be established.
- b) The operating limitations and other information necessary for safe operation must be made available to the pilot, as prescribed in T 1541 to T 1587.

T 1503 **[Operating Limitations**

Airspeed limitations: General

- a) An operating speed range must be established.
- b) When airspeed limitations are a function of weight, weight distribution, altitude, rotor speed or other factors, airspeed limitations corresponding with the critical combinations of these factors must be established.
- c) All flight speeds must be stated in terms of indicated airspeed (IAS).]

T 1505 **Air speed limitations**

- a) All flight speeds must be stated in terms of indicated airspeed (IAS).
- b) The never-exceed speed, V_{NE} , must not exceed 0.90 times the maximum speed demonstrated in flight tests (V_{DF}).
- c) The maximum speed demonstrated in flight V_{DF} must not exceed the Design Maximum Speed, V_D .

T 1519 **Weight and c.g.**

- a) The maximum weight determined under T 25 must be established as an operating limitation.
- b) The c.g. limitations determined under T 23 must be established as operating limitations.
- c) The empty weight and the corresponding c.g. positions must be determined in accordance with T 29.

T 1521 **Powerplant and propeller limitations**

The powerplant and propeller limitations must be established so that they do not exceed the corresponding limits specified by the engine and propeller manufacturers, except that where the gyroplane manufacturer has satisfactorily demonstrated that higher limitations can be used safely with the gyroplane, these may be stated.

T 1527 **[Maximum operating altitude**

The maximum altitude up to which operation is allowed, as limited by flight, structural, powerplant, functional or equipment characteristics, must be established.]

T 1529 **Maintenance manual** (See AMC T 1529.)

A maintenance manual containing the information that the applicant considers essential for proper maintenance must be provided. The applicant must consider at least the following in developing the essential information:

- a) Description of systems;
- b) Lubrication instructions setting forth the frequency and the lubricants and fluids which are to be used in the various systems;
- c) Pressures and electrical loads applicable to the various systems;
- d) Tolerances and adjustments necessary for proper functioning, including control surface travels and limits of rotor pitch angles relative to the hub;
- e) Method of determining c.g. position e.g. hang check;
- f) Methods of rotor tracking and maximum permissible values of play at hinge pins and control circuit backlash;
- g) Identification of primary and secondary structures;
- h) Frequency and extent of inspections necessary for proper maintenance;
- i) Special repair methods applicable to the gyroplane;
- j) Special inspection techniques and maintenance 'cautions';
- k) List of special tools;
- l) Rigging data necessary for proper operation;
- m) Statement of service life limitations (replacement or overhaul) of parts, components and accessories subject to such limitations;
- n) The materials necessary for small repairs;
- o) Care and cleaning recommendations;
- p) Instructions for rigging and de-rigging;
- q) Information on supporting points and measures to be taken to prevent damage during ground transportation; and
- r) List of placards and markings and their locations.
- s) [Any additional procedures to cover storage for prolonged periods over winter or in bad weather.]

Markings and Placards

T 1541 **General**

- a) The gyroplane must be marked with:
 - 1) the markings and placards specified in T 1542 to T 1557; and
 - 2) any additional information, instrument markings, and placards required for the safe operation of the gyroplane.
- b) Each marking and placard prescribed in sub-paragraph a) of this paragraph:
 - 1) must be displayed in a conspicuous place; and
 - 2) may not be easily erased, disfigured or obscured.
- c) The units of measurement used to indicate air speed on placards must be the same as those used on the indicator.

T 1542 **Operating limitations placards and instrument markings** (See AMC T 1542.)

Limitations essential to the safe operation of the gyroplane must be plainly visible to the pilot. Where this cannot be achieved by instrument markings, a placard must be

provided. Where these limitations are shown by instrument markings, each maximum and minimum safe operating limit must be marked by a red line.

T 1543 **[Instrument markings: General**

For each instrument:

- a) when markings are on the cover glass of the instrument, there must be means to maintain the correct alignment of the glass cover with the face of the dial; and
- b) each arc and line must be wide enough and located to be clearly visible to the pilot.]

T 1547 **Compass**

Unless the deviation is less than 5 degrees on all headings, the deviation values for magnetic headings in not more than 30 degree increments must be placarded near the compass.

T 1551 **[Oil quantity indicator**

Each oil quantity indicator must be marked to clearly identify the maximum and minimum quantity of oil that is acceptable.]

T 1553 **Fuel quantity indicator**

Each fuel quantity indicator must be calibrated to read 'zero' during level flight, when the quantity of fuel remaining in the tank is equal to the unusable quantity determined in accordance with T 959.

T 1555 **Control markings**

- a) Each cockpit control, other than primary flight controls, must be clearly marked as to its function and method of operation.
- b) For powerplant fuel controls:
 - 1) each fuel tank selector control must be marked to indicate the position corresponding to each tank; and
 - 2) if safe operation requires the use of any tanks in a specific sequence, that sequence must be marked on or near the selector for those tanks.

T 1557 **Miscellaneous markings and placards**

- a) **Baggage compartment.** Each baggage compartment must have a placard stating the loading limitations.
- b) **Fuel- and oil-filler openings.** The following apply:
 - 1) Fuel-filler openings must be marked at or near the filler cover with the minimum fuel grade and if applicable the fuel/oil ratio;
 - 2) Oil-filler openings must be marked at or near the filler cover:
 - i) with the grade; and
 - ii) if the oil is detergent or non-detergent.
- c) **Fuel tanks.** The usable fuel capacity of each tank must be marked either at the selector or on the gauge (when provided), or on the tank if this is translucent and visible to the pilot in flight.
- d) **In-flight engine starting.** A placard must be provided stating any limitations to be observed during in-flight engine starting.

e) **Loading.**

- 1) Placards. The following data must be placarded in each gyroplane so as to be plainly visible to the pilot:
 - i) Empty weight (actual);
 - ii) Maximum weight;
 - iii) Maximum and minimum cockpit load, including that permitted in each seat;
 - iv) Cockpit load conditions for two seater flown solo; and
 - v) Fuel load limitations for the range of allowable cockpit loads.
 - 2) Removable ballast. If removable ballast is used, the place for carrying ballast must have a placard stating instructions for the proper placement and securing of the removable ballast under each loading condition for which removable ballast is necessary.
- f) **Aerobatic manoeuvres.** A placard prohibiting aerobatic manoeuvres must be plainly visible to the pilot.
- g) **Occupant warning.** A placard showing the standard occupant warning must be plainly visible to the pilot and if applicable the passenger, as follows:

Occupant Warning
This gyroplane has not been certificated to
an international requirement

- h) **Reduction in normal g.** A placard, stating that manoeuvres involving a deliberate reduction in normal g shall be avoided, must be positioned so that it is in full view of the pilot(s).

Pilot's Handbook

T 1581 **General**

- a) A Pilot's Handbook must be furnished with each gyroplane. Each Pilot Handbook must at least contain the information specified in T 1583 to T 1587.
- b) Additional information: Any information not specified in T 1583 to T 1587 which is required for safe operation, or because of unusual design, operating or handling characteristics, must be furnished. (See AMC T 1581 b.)
- c) Units: The units of measurement used must be the same as those used on the indicators.

T 1583 **Operating limitations**

- a) **Airspeed limitations.** The following limitations must be furnished:
 - 1) The air speed limit V_{NE} together with information on the significance of this limit; and
 - 2) Airspeed indicator system calibration.
- b) **Weights.** The following limitations must be furnished:
 - 1) The maximum weight;

- 2) The empty weight and the position of the empty weight c.g. and the condition of the gyroplane required to be established under T 29 b); and
 - 3) The composition of the useful load.
- c) **Loading.** The following limitations must be furnished:
- 1) The weight and c.g. limits required by T 23 and T 25, together with the items included in the empty weight in T 29;
 - 2) Information enabling the pilot of the gyroplane to determine whether the c.g. and the distribution of the useful load in the different loading combinations, are still within the allowable range; and
 - 3) Information for the proper placement of removable ballast under each loading condition for which removable ballast is necessary.
- d) **Manoeuvres.** Authorised manoeuvres established in accordance with T 2.
- e) **Kinds of operation.** The kind of operation, i.e. day VMC, in which the gyroplane may be used, must be stated. The minimum equipment required for operation must be listed.
- f) The maximum wind limitations must be furnished.
- g) **[Powerplant limitations.** The following information must be furnished:
- 1) Limitation required by T 1521;
 - 2) Information necessary for marking the instruments required by T 1542 to T 1553;
 - 3) Fuel and oil designation;
 - 4) For two-stroke engines, fuel/oil ratio.
- h) **Placards.** Placards required by T 1555 to T 1557 must be furnished.]
- i) The [] altitude [established under T1527] must be furnished.

T 1585 **Operating [data and] procedures**

- a) Information concerning normal and emergency procedures and other pertinent information necessary for safe operation must be furnished.
- b) The procedure(s) and speeds for making a take-off in accordance with T 51 and the subsequent climb must be furnished.
- c) The procedure and speed for making a normal approach and landing, and where different, the procedure and speed for making an approach and landing with the engine inoperative, in accordance with T 75 must be provided.
- d) A statement must be made of the maximum crosswind components in which take-off and landing have been demonstrated and whether control was found to be limiting.
- e) The procedure(s) for abandoning a take-off due to engine failure or other cause must be provided.
- f) [For each gyroplane showing compliance with T 1353 g) 2) or g) 3), the operating procedures for disconnecting the battery from its charging source must be furnished.
- g) Information on the total quantity of usable fuel for each tank must be furnished.]
- h) The following information must be furnished:

- 1) The best rate of climb speed, which must not be less than that selected to show compliance with T 65;
 - 2) The airspeed associated with the minimum rate of descent determined in accordance with T 71;
 - 3) The minimum speed for level flight V_{MIN} established in accordance with T 73. (See AMC T 1585 f) 3) and f) 4).); and
 - 4) The minimum control airspeeds $V_{MC (power-off)}$ and $V_{MC (power-on)}$ established in accordance with T 143 and T 149 (see AMC T 1585 f) 3) and f) 4)).
- i) If special procedures are necessary to start the engine in flight, these must be furnished.
 - j) Procedures for the use of any carburettor heat control, (if fitted) must be provided.
 - k) Procedures must be provided for the amendment of the empty weight and composition of the useful load limitations in the pilot handbook and placards, including maximum fuel load to be carried, following periodic weighing of the gyroplane.
 - l) Information must be provided on safe procedures for the assembly, rigging and disassembly likely to be undertaken by the pilot before and after flight, such that inadvertent damage to the gyroplane can be avoided.
 - m) Information must be provided on safe procedures for securing and ground handling of the aircraft.
 - n) [The procedures for landing the aircraft in the event of a fire being detected in the engine compartment and the time available in which to make a safe landing.]

T 1587 Performance information

The following information must be furnished:

- a) The take-off distance determined in accordance with T 51;
- b) The best climb speed;
- c) The speed for minimum rate of descent;
- d) The landing distance determined in accordance with T 75; and
- e) Any limiting height speed envelope determined in accordance with T 79.

Sub-Section J Propellers

Design and Construction

T 1917 **Materials** (See AMC T 1917.)

The suitability and durability of materials used in the propeller must:

- a) be established on the basis of experience or tests; and
- b) conform to specifications that ensure that they have the strength and other properties assumed in the design data.

T 1919 **Durability**

Propeller design and construction must minimise the possibility of the occurrence of an unsafe condition of the propeller between overhauls.

T 1923 **Pitch Control**

- a) [Failure of the propeller pitch control must not cause hazardous overspeeding under intended operation conditions.
- b) If the propeller can be feathered, the control system must be designed to minimize:
 - 1) consequential hazards, such as propeller runaway resulting from malfunction or failure of the control system;
 - 2) the possibility of an unintentional operation.
- c) Failure of the propeller pitch control must not cause deterioration of the minimum climb performance under T 65.]

T 1935 **Blade Retention**

Blade retention devices for propellers with detachable blades must be capable of withstanding a limit load equal to twice the centrifugal force occurring at the maximum rotational speed (other than transient overspeed) for which approval is sought, or the maximum governed rotational speed, as appropriate. (See AMC T 1935.)

T 1941 **[Functional tests**

- a) Each variable pitch propeller (i.e. a propeller the pitch of which can be changed by the pilot or by automatic means while the propeller is rotating) must be subjected to all applicable functional tests of the paragraph. The propeller to be used in the functional test must be either driven by an engine or on a test stand or on a ground running gyroplane and must be the same propeller as used in subsequent endurance tests for compliance under T 923.
- b) On the ground, the propeller must be cycled throughout the usable pitch and engine speed ranges. The total number of cycles must not be less than 50.
- c) In flight, the propeller must be cycled to a minimum of 50 times throughout the allowable ranges of pitch and rotational speed.

T 1945 **Teardown inspection**

After the endurance tests of T 923 have been completed, the propeller must be completely disassembled. No essential component may show rupture, cracks or excessive wear.]

T 1947 **[Propeller adjustments and parts replacement**

The applicant may service and make minor repairs to the propeller during the tests. If major repairs or replacement of parts is found necessary during the tests or in the teardown inspection, any additional tests that the CAA finds necessary must be conducted.]

Part 2 Acceptable Means of Compliance and Interpretative Material (AMC)

Sub-Section A General

[AMC T 2 a) (Interpretative Material)

This code is applicable to amateur built gyroplanes with a maximum all-up (take-off) weight not exceeding 600 kg and to factory built gyroplanes with a maximum all-up (take-off) weight not exceeding 560 kg in accordance with EU Regulation (EC) 216/2008 Annex II.]

AMC T 2 c) [1]) (Interpretative Material)

Gyroplanes which have the facility to make limited pitch adjustments to the rotor blade for the purpose of blade tracking etc. will be considered to have rotor blades of fixed pitch for the purpose of BCAR Section T.

[AMC T 2 c) 2) (Interpretative Material)

Other engine types such as Wankel rotary will be addressed by means of a special condition.]

AMC T 2 d) (Interpretative Material)

E.g. if a horizontal stabiliser incorporating moveable control surfaces is fitted, the gyroplane will not be considered to be of orthodox design.

AMC T 2 g) (Interpretative Material)

Non-aerobatic operation is intended to include:

- 1) any manoeuvre necessary for normal flying;
- 2) steep turns in which the angle of bank does not exceed 60 degrees; and
- 3) vertical descents which do not terminate at ground level.

INTENTIONALLY LEFT BLANK

Sub-Section B Flight

AMC T 21 (Interpretative Material)

- 1) Instrumentation for flight test.
 - a) For test purposes, the gyroplane should be equipped with suitable instruments for conducting the required measurements and observations in a simple manner. If reliable results cannot be obtained otherwise, the CAA may request the installation of special test equipment. In particular, it is recommended that a means be provided of recording the flight instruments, the stick position and the aircraft attitude; e.g. a data recorder or fixed video camera. Provision should also be made to record the pilot's comments as he conducts the flight tests.
 - b) At an early stage in the programme the accuracy of the instruments and their calibration curves should be determined, and particular attention should be paid to the position error of the airspeed indication system.
- 2) Prior to flight test, ground tests should be conducted to measure the following:
 - a) Friction of controls;
 - b) Control-cable tension of closed control circuits; and
 - c) Maximum deflection of control surfaces and their respective controls.
- 3) Functioning tests: Before starting the flight tests, all ground functioning tests should be carried out.
- 4) With reference to T 21 b), if, for example, a gyroplane is equipped with a nacelle and it is intended that the gyroplane may be operated with the nacelle removed, then the gyroplane must be shown to comply with the requirements both with and without the nacelle installed.
- 5) [Refer to AMC T 23 for permitted extrapolation of test results for light weight in lieu of actual testing.]

AMC T 23 (Interpretative Material)

- a) "All possible loading configurations" includes the gyroplane with the rotor attached. For gyroplanes that have a thrust line/centre of gravity limit of offset greater than ± 2 inches, normal distance from the propeller thrust line, the CAA shall be consulted to establish design/equivalent safety standards that would ensure safety objectives continue to be achieved.

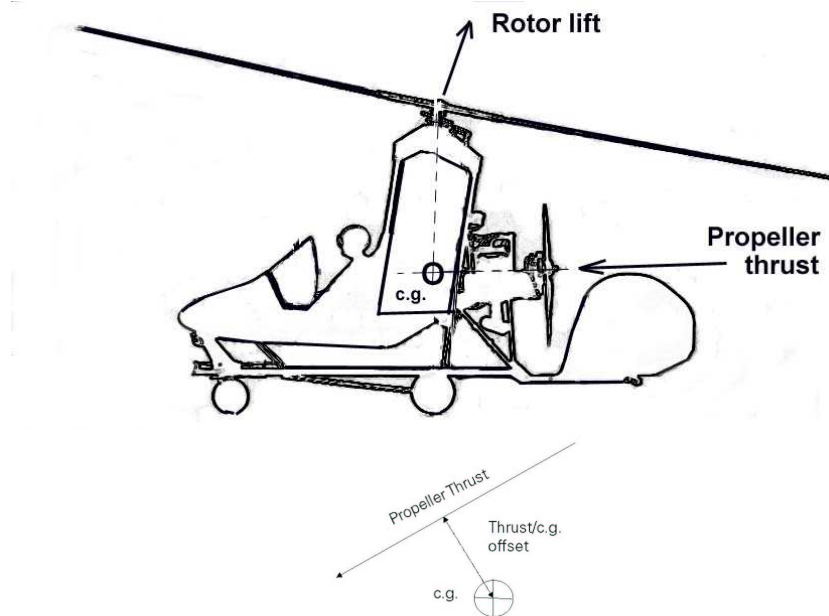

[NOTE: The angle of the propeller thrust line is exaggerated to show that the offset is the perpendicular (normal) distance from the propeller thrust line to the c.g.]

- b) For this class of gyroplane the position of the centre of gravity is normally determined by means of a 'Hang-Check'. The gyroplane is suspended from the rotor attachment point (teeter bolt), and the position of the centre of gravity is determined in terms of the angle, at some suitable point, at which the gyroplane hangs. "Hang Checks" completed using both the rotor attachment point and from a separate hang point, will also identify two vertical lines the intersection of which will provide details of both the horizontal and vertical centre of gravity. The acceptability of other methods of determining vertical/horizontal c.g. position may require agreement with CAA concerning the accuracy of instruments to be used such as scales and the detailed methodology. Vertical centre of gravity position should be determined with the rotor or a representative mass attached.
- c) [The minimum pilot weight of 55 kg referred to in T 23 has a practical implication for flight testing, it may not be possible to find a test pilot of this low weight. Some allowance can be made for extrapolation of results from an assessing pilot heavier than 55 kg. If trends of handling qualities with decreasing weight show that no unacceptable characteristics will exist, then a minimum pilot weight of 55 kg can be accepted. If there is any doubt as to the acceptability of handling qualities, and compliance with all relevant paragraphs of Section T, then it will be necessary to have a placarded minimum pilot weight. This minimum pilot weight requirement could be met by use of suitably secured ballast for light pilots. For gyroplanes with two seats it may be permissible for one or both of the occupants to be less than the solo flight minimum pilot weight provided the c.g. is within the acceptable range and the placard is clearly worded to permit this.]

AMC T 25 c) (Interpretive Material)

Maximum fuel is a variable quantity which is to be established and placarded according to the procedures set down in paragraph T1585 h). On initial manufacture, maximum fuel will equate to full fuel i.e. the capacity of the tank.

AMC T 51 (Interpretive Material)

- a) The distance presented in the Pilot's Handbook should be the mean of six demonstrations increased by a factor of 1.5. Where it is not possible to undertake tests on short grass the CAA shall be consulted to define an acceptable distance factor.
- b) When a rotor spin-up device is installed, the take-off distance should be determined with its use and, if not prohibited in the Pilot's Handbook, without its use, at the most adverse permitted windspeed.

[AMC T 73 (Interpretive Material)

V_{MIN} is primarily intended as a performance parameter i.e. the minimum airspeed at which level flight can be maintained. For a typical pusher configuration gyroplane, this will normally be achieved at maximum power, as propeller slipstream effects will maintain controllability in yaw over the vertical tail surface(s).

It is possible, however, that other configurations, e.g. tractor, may reach a controllability limit at less than maximum power, as propeller slipstream effects will be much less and yaw controllability will be primarily dependent on airspeed.

V_{MIN} can, therefore, be defined by either power availability or low speed controllability. (See also AMC T 149.)

AMC T 79 (Interpretive Material)

The Height-speed envelope is normally referred to as the Height-Velocity (H-V) diagram. A typical H-V diagram for a gyroplane would normally cover critical weight, approximately sea level, ISA conditions and may appear thus, the area to the left of the line defining the envelope of airspeed and height above the ground from which a safe landing following an engine failure is not assured:

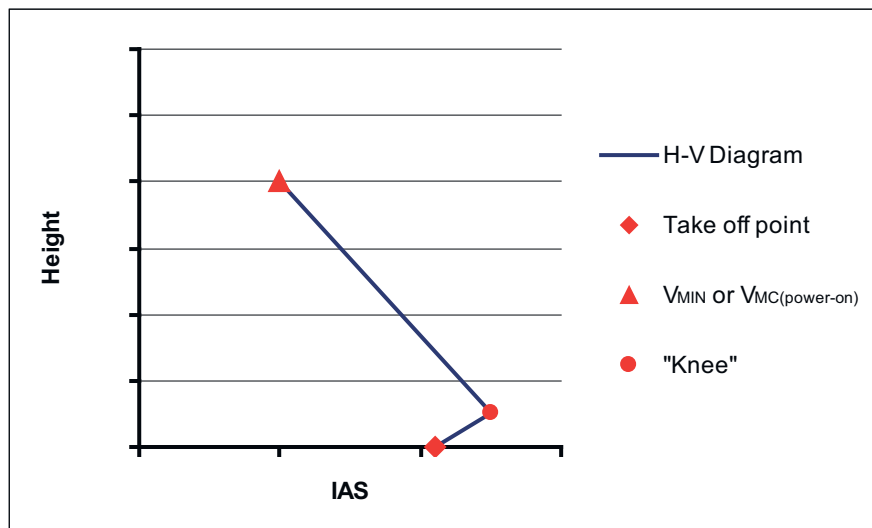

The diagram above consists of 2 distinct portions, a) the take off portion and b) the level flight (cruise) portion. The "knee" separates the take off portion from the cruise portion and represents the highest point of the take off procedure. Up to this point, normal pilot intervention time of approximately 0.5 sec should be applied between failing the engine and initiation of recovery action. In the cruise portion above the knee and at airspeeds greater than V_{MIN} , an intervention time of 1 sec can be used.】

[Experience has shown that it is not normally necessary to conduct actual engine shut downs as the residual thrust of an idling engine has little effect on the final outcome of the tests.

It is recommended that investigation of upper portions of the H-V curve be conducted, as far as possible, at a safe altitude, with a power recovery. Only when there is confidence in the validity of the curve should limited testing be carried out to a landing. Clearly, the testing of the take off portion can only be conducted to a landing.

Testing should be conducted as close as possible to the maximum permitted gross weight and in low wind speeds - <3kt. Applicants should be alert to the possibility of a tail wind component occurring when testing in light and variable wind conditions as this could result in a significant increase of the height required to carry out a safe landing.

- a) **Take-off portion.** A selection of airspeed/height points between the take-off point and the knee should be investigated. The knee will usually be around the best rate of climb speed (V_Y) and the height at which this is achieved after take off. Having determined this point, testing should be initiated by stabilising the aircraft at the height of the knee, but at a higher airspeed, above the runway, and closing the throttle to idle. Initial test points should be undertaken using a gentle throttle closure and immediate corrective action. The rate of throttle closure and pilot delay can then be progressively increased until a rapid throttle closure and the appropriate intervention time are achieved. A series of tests should then be conducted at progressively decreasing airspeeds until the actual knee point has been established by reaching a limiting case e.g. maximum rate of descent on landing, pilot workload or controllability. This procedure can then be repeated at one or more intermediate points between the take off point and the knee.

Having satisfactorily investigated the lower portion from steady state entry conditions, a sample of points on the line should be investigated dynamically during take off. Again, caution should be exercised, as the behaviour of the aircraft will be different in the dynamic case. Testing at a lighter weight, with no delay is recommended initially. The end point should be considered to be maximum gross weight, maximum take off power and 0.5 sec pilot delay.

- b) **Cruise portion.** It will be necessary to demonstrate a number of points between the knee and V_{MIN} . Initial testing should be performed at a safe altitude, with the height loss to recover to a simulated flare and landing being estimated for each selected airspeed. These points can then be investigated in a progressive manner as above, the aircraft being stabilised at the required height, but at a higher than desired airspeed. Airspeed can then be progressively reduced to the desired H-V point, and pilot delay increased to 1 sec.

- c) **Airspeeds less than V_{MIN} .** In the case that $V_{MC (power-on)}$ is less than V_{MIN} , limited flight testing should be carried out to determine the approximate height loss in recovery from the following conditions:

- i) $V_{MC (power-on)}$ in a stabilised rate of descent at the appropriate power setting, closing the throttle to simulate power failure and initiating a recovery after a 0.5 second delay. The height loss from the point of throttle closure should be determined.
- ii) $V_{MC (power-off)}$ in a stabilised rate of descent at idle power. The engine is assumed not to respond for the recovery and the height loss measured from the point where the engine would normally have responded.]

[The testing should be carried out in free air only, landings from this condition are not required. The height loss to recover to a simulated flare and landing being estimated for each condition. The handbook should state the height loss for these descent conditions but also state that it is an estimate and not an absolute value.

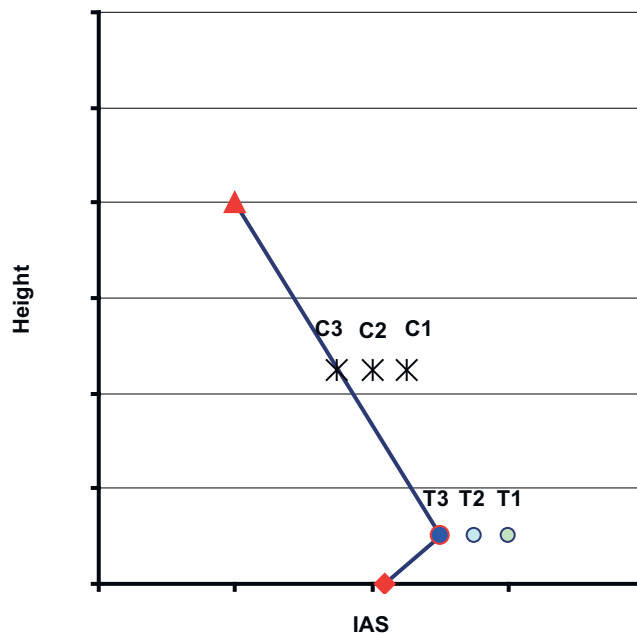

The incremental approach for test points to a landing is illustrated in the diagram above:

For the cruise portion the speed is reduced (C1, C2, C3).

For the take off portion the speed is reduced (T1, T2, T3).]

AMC T 143 a) [1]] (Interpretative Material)

[] It will be necessary to show that there is a margin beyond the gyroplane’s specified limitations within which the gyroplane is safely controllable and manoeuvrable.

The size of the margin will depend on the handling characteristics of the gyroplane, and must be agreed with the CAA, [but in general, it will be expected that satisfactory flight characteristics have been demonstrated at speeds up to 1.11 V_{NE} . This demonstration must include satisfactory control margin and rotor clearance. (See also T 661.)]

[]

[AMC T 143 a) 3] (Interpretative Material)

Having established $V_{MC (power-off)}$ and either V_{MIN} or $V_{MC (power-on)}$ under T 73 and T 149, if $V_{MC (power-off)}$ is greater than either V_{MIN} or $V_{MC (power-on)}$ it must be shown that, it is possible to recover the gyroplane in the event of an engine failure at the lowest power-on minimum airspeed. This should be done by carrying out simulated engine failures at incrementally reducing airspeeds down to the lowest power-on airspeed. The aircraft should be established at the chosen incremental speed which should initially be at $V_{MC (power-off)}$, and the throttle carefully closed to idle whilst simultaneously increasing airspeed. The rate of throttle closure can then be incrementally increased until an engine failure has been simulated. Having successfully demonstrated a simulated engine failure with immediate recovery, the tests should be continued with increasing pilot intervention time. The objective is ultimately to simulate an engine failure with a realistic intervention time of around]

[0.5 sec. Having achieved a successful test point, further tests can be carried out at incrementally lower airspeeds with the aircraft being accelerated to $V_{MC (power-off)}$ following engine failure until the limiting power-on minimum airspeed is demonstrated. Following determination of this speed, confirmation flight testing should be conducted in an incremental manner (first test points at higher speed) with real engine shutdowns over a suitable landing site.

If at any time, the ability to recover the aircraft to a safe idle glide is in doubt, this is indicative that the power-on minimum airspeed is too low. The investigation must be continued to establish a minimum power-on airspeed that allows safe recovery following engine failure and this should be declared as the limiting flight condition, $V_{MC (power-on)}$.

AMC T 143 b) (Interpretative Material)

It must be assured that no unacceptable coupling to attitude is experienced with rapid applications of throttle (e.g. go around) or rapid power loss (e.g. engine failure). This may be particularly apparent with gyroplanes which have an exaggerated thrust line/vertical c.g. offset. For example, slow speed flight in a gyroplane with a high thrust line will result in a nose down pitch couple from thrust which must be opposed by aft control displacement. At the point of engine failure, the nose down couple is lost and the nose up pitch attitude can increase very rapidly before the pilot intervenes. Although the pitch axis is most noticeably affected, engine torque effects can couple to roll and yaw and must also be considered.]

AMC T 145 c) (Interpretative Material)

- a) The control force required over the range of control movement should neither vary excessively nor exhibit any undesirable discontinuities.
- b) From trimmed initial conditions, the control forces required for executing normal operational manoeuvres should not exceed:
 - 1) a stick force of 27 N; and
 - 2) a pedal force of 90 N.

[AMC T 149 (Interpretative Material)]

It is recommended that $V_{MC (power-off)}$ be established before exploration of V_{MIN} and $V_{MC (power-on)}$ is commenced in order that, in the event of an actual engine failure during the power-on exploration, the recovery action is well understood.

- a) $V_{MC (power-off)}$ is the lowest airspeed, IAS, at which control of the aircraft is assured with the engine shut down. Investigation should be conducted in a cautious and progressive manner by establishing the aircraft in level flight at or around minimum power airspeed at a safe altitude and closing the throttle to idle. Airspeed should then be decreased incrementally until a control, typically in the yaw axis, becomes ineffective or limited. Power should then be applied and airspeed increased to recover as required. Following determination of this speed, confirmation flight testing should be conducted in an incremental manner (first test points at higher speed) with real engine shutdowns over a suitable landing site. An intervention time of approximately 0.5 sec should be applied between failing the engine and initiation of recovery action.
- b) $V_{MC (power-on)}$ is the lowest airspeed, IAS, at which the gyroplane is still fully controllable in all axes with power applied. Most contemporary light gyroplanes are of a compact pusher configuration and the vertical surfaces are subject to considerable propeller slipstream effects at low speed, high power, and control may be possible even at zero airspeed (with a corresponding rate of descent).]

Some autogyro configurations, e.g. tractor types, may have limited propeller slipstream effect on the fin/rudder. In this case directional stability and control may be primarily dependent on airspeed with control limits being reached in level flight at an airspeed with less than full power.

$V_{MC (power-on)}$ should be investigated concurrent with the investigation of V_{MIN} in T 73. The gyroplane should be stabilised in level flight at approximately minimum power airspeed. Airspeed should then be progressively reduced and power increased to maintain level flight. If a controllability limit or other limiting factor (e.g. rotor rpm, handling qualities) is reached before maximum power has been required, the testing should be terminated and this airspeed defined as $V_{MC (power-on)}$, and would therefore be coincident with V_{MIN} . If maximum power is achieved with controllability still being maintained, this airspeed should be defined as $V_{MC (power-on)}$. The gyroplane will be in a descent in this case.

[AMC T 155 (Interpretative Material)]

Increasing the positive load factor on a gyroplane should be accomplished by a linear aft stick force and/or position. Combined with visual, audio and vibration cues, the tactile cueing from the stick should make the onset of a limiting load factor clearly discernible to the pilot.]

AMC T 173 a) (Interpretative Material)

[The control requirement of this section is so essential to basic flight mechanics that compliance may be found during conventional flight testing for compliance with other sections. No special or designated testing should be required.

AMC T 173 b) (Interpretative Material)

Whilst the requirement states “Throughout the full range of altitude for which certification is requested...”, it is permissible to carry out the climb testing for T 175 a) at a lower altitude than the maximum requested; extrapolation of the results to approximately an additional 2000 ft would be appropriate. If the rate of climb is very low, a greater extrapolation would be appropriate.

It is recognised that control force will be difficult to quantify in this class of aircraft. It is acceptable to present quantitative information relating to the control positions, and a qualitative statement of the control force characteristics.

Example of a positive or stable slope for control position versus airspeed:

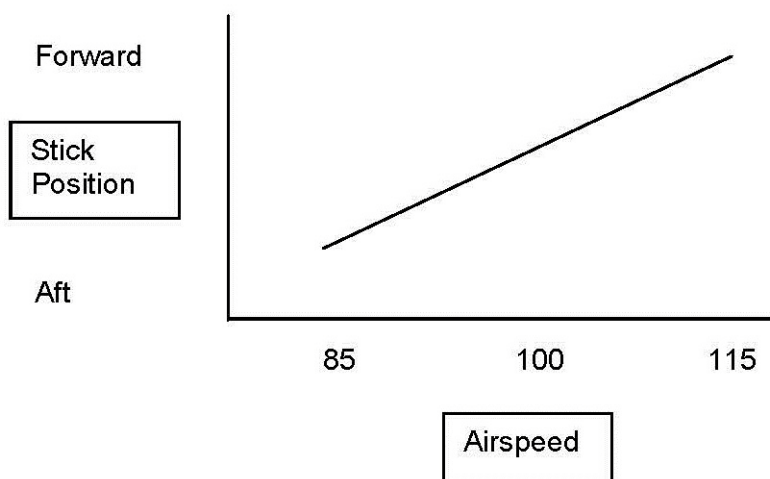

]

[AMC T 177 a) Interpretive Material

The aircraft should be directionally and laterally stable. Traditionally aeroplanes have had to demonstrate directional stability with the rudder (yaw control) both fixed and free. In a recreational gyroplane the pilot is likely to have their feet on the rudder pedals at all times in flight and unless the rudder cables break the rudder free case is academic. However a yaw disturbance or sideslip with the rudder free should not allow an excessive yaw rate or lead to a dangerous condition. Consideration should be given to the rudder cable failure case.]

AMC T 181 (Interpretive Material)

Longitudinal, lateral or directional oscillations with controls fixed or free [for longitudinal and lateral controls (but fixed for the yaw control)] and following a single disturbance in smooth air, should at least meet the following criteria:

- a) Any oscillation having a period of less than 5 seconds should damp to one half amplitude in not more than one cycle. There should be no tendency for undamped small amplitude oscillations to persist.
- b) Any oscillation having a period between 5 and 10 seconds should damp to one half amplitude in not more than two cycles. There should be no tendency for undamped small oscillations to persist.
- c) Any oscillation having a period between 10 and 20 seconds should be damped, and in no circumstances should an oscillation having a period greater than 20 seconds achieve more than double amplitude in less than 20 seconds.

For gyroplanes with an in flight adjustable variable trim control, where possible, the gyroplane should initially be trimmed at the required flight condition. [] The disturbance can then be introduced by moving one primary flight control to an out-of-trim position [in one of axis sufficient to change the attitude of the gyroplane by approximately 5 degrees with the other primary controls held fixed and immediately returning it to its original trim position. If assessing stick (or yaw control) fixed rather than free, the stick (or yaw control) should be held with normal control force once returned to trim.] Initially, a small input should be employed, sufficient to generate an attitude rate of no more than approx 3 - 5°/sec. The amplitude of the input can then be incrementally increased to generate an adequate pitch rate in the order of 5 - 10°/sec. Extreme caution must be exercised during this evaluation, particularly when considering the potential for rapidly reducing 'G', either as a direct result of an input, or as an indirect result during the ensuing phugoid response. Consideration should be given to some form of measurement of structural clearances for this testing, for example a 'video camera'.

For those gyroplanes which do not have a variable trim control or which have a variable trim control with insufficient authority to trim at all conditions, the method of exciting the oscillation is the same and the control must be returned to [its original position and then fixed if assessing "stick fixed" stability or held loosely without applying any force for "stick free".] As it may not have been possible to establish a trim condition with zero control force, care must be taken to ensure that the control is returned to datum following the disturbance.

AMC T 235 a) (Interpretive Material)

The gyroplane should at least be suitable for operation from surfaces with short grass.

AMC T 241 (Interpretive Material)

Compliance with this requirement may be shown by demonstrating that the gyroplane has no dangerous tendency to oscillate during rotor spin-up, take-off,

landing and taxiing. A range should be tested to represent the variations in the way these conditions may be conducted in service.

AMC T 321 b) (Interpretative Material)

Altitude is not normally critical for propeller torque and thrust, which are normally greatest at sea level.

AMC T 397 (Interpretative Material)

For unconventional control systems, the design loads should reflect the most sensible mode of operation for the control, e.g. depending on the sense of operation, a hand-operated rudder should be designed for the loads appropriate for either a pitch or roll control.

INTENTIONALLY LEFT BLANK

Sub-Section C Structure

AMC T 307 a) (Interpretative Material)

- 1) Substantiating load tests made in accordance with T 307 should normally be taken to ultimate load.
- 2) The results obtained from strength tests should be so corrected for departures from the mechanical properties and dimensions assumed in the design calculations as to establish that the possibility of any structure having a strength less than the design value, owing to material and dimensional variation, is extremely remote.

AMC T 337 (Interpretative Material)

The structure of the gyroplane must be shown to be able to withstand these loads. It is not necessary to show that the aircraft is controllable, or that the fuel or other aircraft systems work at these extremes.

AMC T 405 (Interpretative Material)

Hand and foot loads, assumed for design, should not be less than the following:

- 1) Hand loads on small hand-wheels, cranks etc., applied by finger or wrist force: $P = 150 \text{ N}$.
- 2) Hand loads on levers and hand-wheels applied by the force of an unsupported arm without making use of body weight: $P = 350 \text{ N}$.
- 3) Hand loads on levers and hand-grips applied by the force of a supported arm or by making use of the body weight: $P = 600 \text{ N}$;
- 4) Foot loads applied by the pilot when sitting with his back supported (e.g. toe-brake operating loads): $P = 750 \text{ N}$.

AMC T 473 (Interpretative Material)

- 1) Where the shock absorber characteristics are not essentially affected by the rate of compression, static tests may be used to establish compliance.
- 2) In the absence of a more rational analysis, the energy to be absorbed horizontally by the nose gear, as required by Paragraph T 473 c), may be assumed to be 50% of the total vertical energy corresponding to the condition referred to in T 473 b) 2).

[AMC T474 (Interpretative Material)

It should be noted that the inertia factors of paragraphs a) and d) above are related to the whole aircraft whilst the landing gear factors of b) and c) are related to the landing gear only. The rotor lift factor must be added to the landing gear reaction factor of b) and c) to obtain the aircraft inertia factor.

AMC T 479 a) 2) (Interpretative material)

- a) For gyroplanes with nose wheels, the same attitude may be used in both sub-paragraphs i) and ii) but in the analysis associated with sub-paragraph ii) the nose gear reaction is to be assumed to remain zero.

AMC T 485 (Interpretative Material)

The effect of yawing acceleration due to side loads during landing should be considered to act on the whole aircraft structure.]

AMC T 547 c) (Interpretative Material)

Compliance may be shown by satisfactory completion of the endurance test of T 923.

AMC T 549 c) (Interpretative Material)

Gyroscopic moments should be derived for angular velocities about the pitch and yaw axes, for the rotating parts of the powerplant (including the engine, gearbox and propeller).

AMC T 561 d) (Interpretative Material)

The purpose of this requirement is to ensure that the engine and associated high mass items are adequately restrained in the event of a heavy landing. In order to show compliance with the requirement, the inertial loads resulting from the deceleration of 15 g must be diffused through the gyroplane structure in a realistic manner.

AMC T 597 (Interpretative Material)

Ballast includes (but is not limited to) removable ballast and will be considered as part of the equipment of the gyroplane and therefore subject to compliance with the requirements of Section T in general and T 561 c) and T 597 in particular.

[The emergency load factors in T 561 b) are defined as ultimate conditions. For compliance with T 597, the ultimate flight and ground load cases must also be considered as crash cases can be less severe.]

Sub-Section D Design and Construction

AMC T 603 b) (Interpretative Material)

If non-aerospace specifications are to be used they must be from a source acceptable to the CAA.

[AMC T 607 b) (Interpretive Material)

A self-locking stiff nut and plain washer combination, when subject to rotation, may be considered an acceptable means of compliance when used in conjunction with a 'torque stripe' applied to the connection in those circumstances where:

- 1) no de-torque force either cyclic or continuous is applied to the connected assembly; and
- 2) that assembly is clearly visible to inspection; and
- 3) failure cases such as a bearing or sleeve seizure should be considered during application and interpretation of 607 b).

Definition and interpretations

Rotation:

May include but not be limited to:

- 1) Any connection subject to rotation about the axis of the connecting elements.
- 2) Any connection subject to angular oscillation about the axis of the connecting elements.

Torque stripe:

- 1) A 'torque stripe' is a clearly visible continuous line applied to and running down the axis of connecting elements that would show, without ambiguity, if the connecting elements have been disturbed from their original position.
- 2) A torque stripe is not a means of locking but an inspection aid.
- 3) A 'torque stripe' shall be of a medium that can be easily applied and identified.
- 4) A 'torque stripe' shall be fit for purpose and not easily removed during normal operating conditions.

AMC T 612 (Interpretive Material)

The requirement is intended to cover whatever actions are needed to get the gyroplane from the condition for transporting or storage (de-rigging) to the conditions for safe flight (rigging). These actions should be identified by the manufacturer in the operator's handbook. (See T 1581).]

AMC T 613 b) (Interpretative Material)

Material specifications should be those contained in documents accepted either specifically by the CAA or by having been prepared by an organisation or person which the CAA accepts has the necessary capabilities. In defining design properties, these material specification values should be modified and/or extended as necessary by the constructor to take account of manufacturing practices (for example, method of construction, forming, machining and subsequent heat treatment).

AMC T 613 c) (Interpretative Material)

Hot Soak temperatures up to 54° C are considered to correspond to normal operating conditions.

AMC T 619 a) (Interpretative Material)

Appropriate combinations of the special factors should include all those of the following appropriate to the part:

- 1) The casting factor derived in accordance with T 621;
- 2) The highest pertinent special factor prescribed in T 619 b), T 623, T 625, T 657, or T 693; and
- 3) The two-hinge factor prescribed in T 625 e).

AMC T 619 b) (Interpretative Material)

For composite materials such as fibre reinforced plastics, an appropriate factor to allow for variability and environmental effects should be applied to ultimate loads. This should be at least 1.5 where the strength is to be substantiated by test at ambient temperature, but may be reduced to 1.2 for conditioned items (i.e. subjected to environmental exposure) that are tested at the maximum temperature likely to be achieved in normal operation.

AMC T 626 (Interpretative Material)

Nominal cable strength is defined by the minimum breaking load for the particular type of cable specified in the British Standard, or other acceptable recognised specifications to which the cable is made. Reference to the relevant specification must be made in the design documentation. These criteria apply to steel cables. Design assumptions for cables of other materials should be agreed with the CAA.

AMC T 661 (Interpretative Material)

It will be necessary to conduct ground and flight trials and to record, by some suitable means, the clearance between the rotor blades and hub and the airframe, teeter stops and propeller, to show compliance with this requirement. The range of conditions covered must be adequate to ensure that the most severe conditions that can be expected to occur in flight or on the ground are covered.

AMC T 685 b) (Interpretative Material)

For the purpose of this requirement a cockpit can be assumed to be an enclosed or semi enclosed nacelle.

AMC T 689 b) (Interpretative Material)

The inside diameter of the pulley groove should not be less than 300 times the diameter of each elemental strand.

AMC T 773 a) (Interpretative Material)

In order to show compliance with this requirement it will be necessary to assess the effects of any 'misting up' of the windscreen.

AMC T 773 b) (Interpretative Material)

Compliance with T 773 b) may be provided by any canopy having a suitable opening.

AMC T 773 c) (Interpretative Material)

Attitude control of light gyroplanes is largely dependent on the pilot being able to fly by reference to external visual cues. Certain gyroplane configurations such as pusher types with an open cockpit, have limited airframe structure ahead of the pilot. In order

to meet the intent of this requirement, sufficient airframe structure should be within the pilot's normal field of view close enough to the natural position of the horizon in trimmed level flight to allow attitude control. This may require a dedicated attitude reference e.g. a "T-bar" or reference on the windscreen.

AMC T 777 a) (Interpretative Material)

For unconventional control systems, the function and sense of the control should be placarded.

AMC T 777 b) (Interpretative Material)

When assessing whether the cockpit controls comply with T 777 b) allowance must be made for bulky winter clothing.

AMC T 779 (Interpretative Material)

1) Trim

The trim control should be mounted in the most logical plane of operation with the axis parallel to the primary control axis. For example, for pitch trim the wheel would be in the vertical plane such that a forward motion of the top of the wheel trims pitch nose down. Some allowance can be made for displacing the axis to improve access by the pilot or due to over-riding design constraints but it would not generally be acceptable for the axis to be significantly displaced, for example by 90°.

For trim wheels the sense of motion should be as follows:

Pitch: Top of wheel moves forward for trim nose down.

Roll: Top of wheel moves right to trim "right wing" low.

Yaw: Top of wheel (forward part) moves right to yaw nose right.

If only a portion of a wheel is accessible, the direction of the pilot's hand movement must be in the same sense as gyroplane motion.

2) Throttle Control

For twist-grip engine power controls, for left-hand operation the motion of the pilot's hand is clockwise to increase power when the hand is viewed from the edge containing the index finger.

AMC T 785 a) (Interpretative Material)

Although the occupant weight for design must be not less than [90] kg, typical weight of equipped heavier crew should be considered.

[The emergency load factors in T 561 b) are defined as ultimate conditions. For compliance with T 785 a), the ultimate flight and ground load cases must also be considered as crash cases can be less severe.]

AMC T 785 c) and d) (Interpretative Material)

These requirements should be read in conjunction with Paragraph T 1307.

[The following minimum cases of forward load distribution should be considered:

- 1) 100% of the forward load applied to the belt;
- 2) 60% of the forward load applied to the belt and 40% to the shoulder strap(s).

For the upward load case, the complete harness system should be able to carry 100% of the vertical load.]

AMC T 786 a) (Interpretative material)

[] It is recommended that rigid structural members are not located in a position likely to cause injury in such a crash-landing.[]

[AMC T 786 b) (Interpretive Material)

The use of energy absorbent foam (i.e. visco-elastic memory foam) in seat cushions can significantly reduce the impact loads being applied to the occupant's spine. The use of energy absorbing foam with a thickness of between 1 and 1.5 inches in the seat cushions is recommended in order to minimise occupant injuries.

However, it has also been found that the simplistic use of foam cushions used for comfort may result in the potential for increased injury.

Particular care should be taken to ensure that the seat cushions are suitably secured and restrained in order to prevent potential obstruction/interference with flying controls or damage to the propeller or other rotating parts.】

Sub-Section E Powerplant

AMC T 903 (Interpretative Material)

Evidence of safe and satisfactory operation of the engine and propeller combination in the gyroplane, for a period of 25 hours flying without significant problems, is an acceptable means of demonstrating compliance.

Note that if significant changes are made to the engine, additional flying may be necessary to ensure that a complete period of 25 hours is achieved with the final standard of engine in combination with the proposed propeller.

A significant aspect of engine/propeller/airframe compatibility is the effect of gyroscopic forces. The 25-hour flight test should be representative of the most severe manoeuvres likely to be experienced during normal operation, including manoeuvres which generate high yaw rates.

AMC T 923 (Interpretative Material)

The flight test schedule should be made up of a number of flights representative of normal use. These flights should cover the range of ground and flight conditions that the gyroplane is expected to experience in normal use. The applicant may count any development flight hours flown towards the 25 hours of endurance testing, provided the gyroplane is in the final configuration and the test flying was representative of the operational use.

These conditions should be flown over the permitted range of engine power and rotor rpm, all-up weight, c.g. position and altitude.

Where a rotor spin-up device and/or a rotor brake is to be fitted, the flight endurance tests should be carried out using these devices.

The gyroplane should be inspected carefully at regular intervals as the trial proceeds. Records should be kept of the results of these inspections and of the flying carried out. If any problems or failures occur, the CAA should be advised of the problem and the proposed solution. Depending on the severity of the problem, extra flying may be necessary to ensure that the proposed solution has accrued 25 hours without a recurrence of the problem.

AMC T 923 c) (Interpretative Material)

The purpose of this endurance test is to gain some confidence that the rotor will not behave dangerously when flight tested.

The testing should also be used to confirm (as far as possible), that the behaviour of the rotor system is reasonably close to that assumed by the designer. This could be shown crudely by comparing predicted rotor rpm with that achieved on test.

A suitable test vehicle would be a 'boom trailer', i.e. similar to a gyroglider but fixed mechanically by a boom to the towing vehicle, to limit the achievable height.

[AMC T 925 a) (Interpretative Material)

There should be a ground clearance of at least 180 mm for a gyroplane with a nose-wheel landing gear or 230 mm for a gyroplane with a conventional tractor propeller and a tail-wheel landing gear.]

AMC T 925 b) (Interpretative Material)

This requirement is intended to take account of airframe flexure under all conditions likely to be encountered in flight or on the ground, including hard landings and taxiing over rough ground. In the absence of more rational information, it is recommended that there should be:

- 1) at least 25 mm radial clearance between the blade tips and other parts of the gyroplane, plus any additional radial clearance necessary to prevent harmful vibration, and at least 100 mm radial clearance from items capable of large deflections, when they are fully deflected to minimise the clearance; and
- 2) a minimum longitudinal propeller clearance, to allow for airframe and propeller flexibility, varying linearly between 13 mm at the hub and 50 mm at the blade tip.

AMC T 925 c) (Interpretative Material)

This requirement is intended to prevent accidental injuries caused by the occupants inadvertently contacting the propeller in ground and flight conditions (including a heavy landing). It is not intended to prevent an occupant from deliberately contacting the propeller.

AMC T 955 (Interpretative Material)

Note that the fuel consumption quoted by the manufacturer may be for relatively low throttle openings, not the high-power case applicable to this requirement.

[AMC T 961 (Interpretative Material)

The intent of the requirement is to ensure uninterrupted fuel flow to the engine during hot weather operation. This is generally accepted to be achieved by continuously pumped systems but in the case of suction feed systems or other fuel systems with features conducive to vapour formation, a test is required. If pumps are provided but only used in emergency then these should be inoperative for the test.

The test should demonstrate that the fuel pressure to the engine is maintained above the engine manufacturer's limit or that the engine operates satisfactorily, up to the maximum declared operating altitude and engine power level.

Vapour release from the fuel, which can affect fuel feed and engine operation, is influenced by a number of factors, including:

- i) Fuel flowrate;
- ii) Fuel type;
- iii) Fuel temperature;
- iv) Head of fuel in the tank;
- v) Ambient pressure (altitude).

Therefore when conducting a test, the engine should be operated at take-off power for the maximum time limitation then maximum continuous power. The fuel in the tank should be the minimum required for the test and should represent the most critical fuel in terms of vapour pressure, such as Mogas unweathered winter grade. The fuel temperature at the start of the test should be at least 43°C. The ambient temperature should be the highest available, with consideration given to insulating fuel lines and components if the test is carried out in cold weather conditions. These test parameters will achieve maximum fuel flowrate and maximum rate of climb and should represent the most critical operating conditions established for the rotorcraft.]

AMC T 967 c) (Interpretative Material)

If the tank is mounted above, below or behind the engine or the exhaust, a fireproof shield must be placed between the fuel tank and the engine or exhaust. If the fuel tank is mounted above the engine or exhaust, there must be provision to catch and drain fuel leaks away from the engine and exhaust.

AMC T 977 d) (Interpretative Material)

Additives in many two-stroke engine oils can, under certain conditions, produce materials which will block paper filter elements with pore sizes of less than 10 microns. Such paper elements will not be considered compatible with two-stroke pre-mix fuel systems.

AMC T 993 a) (Interpretative Material)

Compliance with the requirements of this sub-paragraph may be shown by flight test.

[AMC T 993 e) (Interpretative Material)

For engine installations with fuel lines that cannot easily be moved or routed away from hot surfaces such as exhausts, splash or drip shields may be used in conjunction with adequate drainage.

AMC T 1011 c) (Interpretative material)

In assessing the reliance that can be placed upon the means for providing the appropriate fuel/oil mixture to the engine to prevent a hazardous condition, account should be taken of, for example:

- a) The tolerance of the engine to fuel/oil mixture ratios other than the optimum;
- b) The procedure established for refuelling and introducing the appropriate amount of oil; and
- c) The means by which the pilot may check that the fuel contains an adequate mixture of oil.

AMC T 1041 (Interpretative Material)

The instrumented gyroplane should be tested both on the ground and in the air and the engine temperatures recorded. Some extrapolation of these engine temperatures is permitted to cover air temperature extremes. A minimum of 3 temperature points should be used for this testing.]

AMC T 1091 (Interpretative Material)

Compliance with this requirement may be shown by satisfactory completion of the flight endurance test of T 923.

AMC T 1145 a) (Interpretative Material)

Magneto ignition switches should be rendered inoperative by grounding the appropriate circuit to earth.

[AMC T 1187 (Interpretative Material)

The intent of this requirement is to reduce the risk of fire due to the build up of flammable vapours.]

INTENTIONALLY LEFT BLANK

Sub-Section F Equipment

AMC T 1301 a) 3) (Interpretative Material)

Each item of required equipment should function correctly when subjected to the most adverse likely operating conditions including extremes of temperature, rain and humidity.

When radio equipment is installed, it should be shown that the electrical system is such that the operation of this equipment is not adversely affected.

[AMC T 1303 d) (Interpretative Material)

A 'thread wool' would be accepted as a means of compliance with this requirement.]

AMC T 1303 e) (Interpretative Material)

An analogue display that would clearly identify trends in rotor speed variation rather than numerical or particular values, would be accepted as a means of compliance with this requirement.

AMC T 1307 (Interpretative Material)

[]

Installation of Shoulder Harness

Figures 1, 2 and 3 show the recommended installation geometry for this type of restraint.

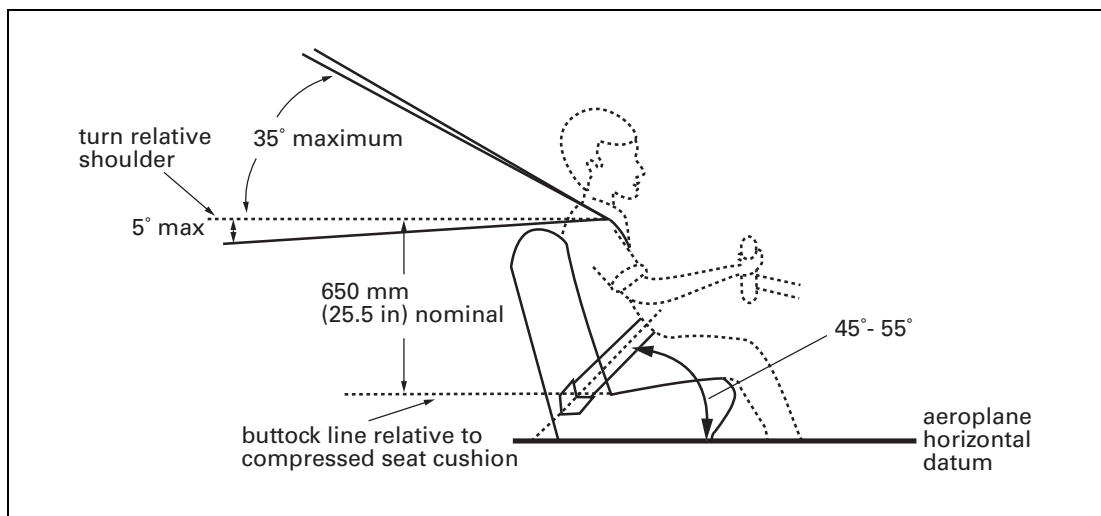

Figure 1

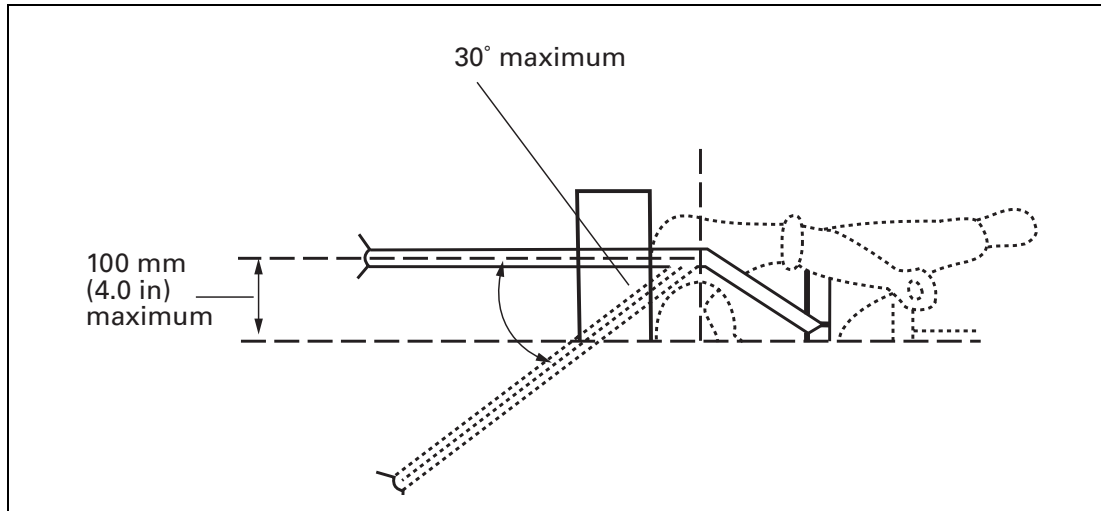

Figure 2 Range of Angles of Shoulder Straps

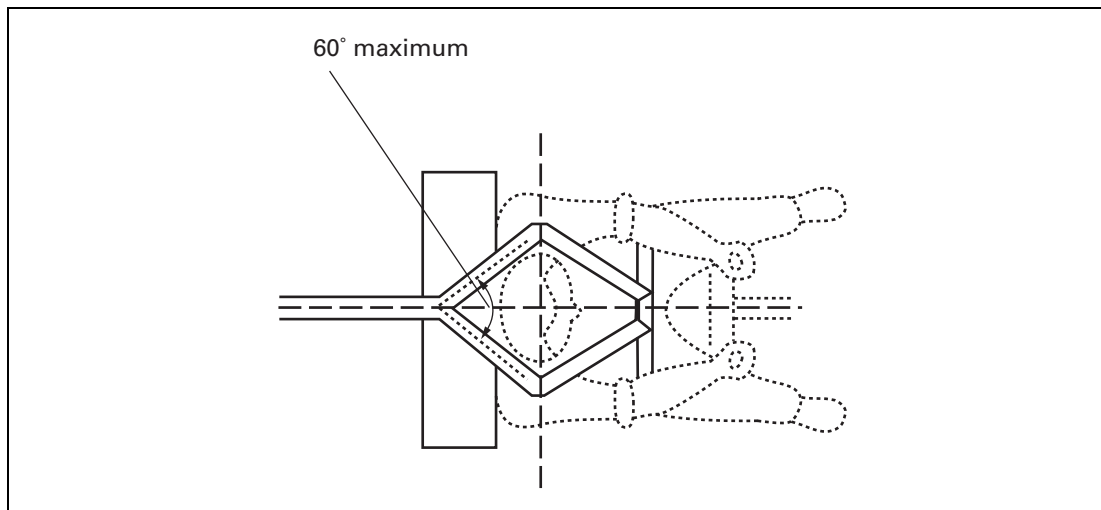

Figure 3

- NOTES:**
- 1) Where there is more than 150 mm of webbing between the attachment point of the shoulder straps and the top of the seat back, suitable means should be provided to limit sideways movement e.g. guide loops, to ensure adequate separation of shoulder straps to minimise injury or chafing of the wearer's neck.
 - 2) Where the seat back is of adequate strength and such height that the harness geometry relative to the shoulder conforms with the above Figure (i.e. 650 mm), it is permissible to attach the shoulder straps to the seat back via guide loops to the gyroplane floor.

[AMC T 1361 a) (Interpretative Material)

The master switch arrangement may consist of separate switches, one for each source of electrical power i.e. generator(s) and battery.

Such arrangements should be able to be operated by one hand with a single movement.

AMC T 1365 c) (Interpretative Material)

- 1) Certain electrical cables comprise insulating of materials that are known to pose a hazard in confined areas, e.g. Plasticised-PVC (PVC-P), where in overheat conditions, the insulation can form hydrogen chloride fumes which pose a health hazard, and may be released in dangerous quantities.
- 2) The term 'dangerous quantities of toxic fumes' refers to any adverse effect that the release of smoke or fumes could have on the capability of the pilot such that it impaired their ability to continue to safely fly the aircraft to a safe landing. (The term is to be assessed qualitatively only using engineering and operational judgement; a numerical analysis is not intended.)
- 3) Associated equipment includes:
 - i) Wires and cables;
 - ii) Bus bars;
 - iii) The termination point on electrical devices, including those on relays, interrupters, switches, contactors, terminal blocks, and circuit breakers and other circuit protection devices;
 - iv) Connectors, including feed-through connectors;
 - v) Connector accessories;
 - vi) Electrical grounding and bonding devices and their associated connections;
 - vii) Electrical splices;
 - viii) Materials used to provide additional protection for wires, including wire insulation, wire sleeving, and conduits that have electrical termination for the purpose of bonding;
 - ix) Shields or braids;
 - x) Clamps and other devices used to route and support the wire bundle.
 - xi) Cable tie devices;
 - xii) Labels or other means of identification;
 - xiii) Pressure seals.
- 4) 'Flame resistant' means not susceptible to combustion to the point of propagating a flame, beyond safe limits, after the ignition source is removed.

AMC T 1431 a) (Interpretative material)

Particular care should be taken to ensure electronic systems essential to safety in flight are not adversely affected by electromagnetic interference.】

INTENTIONALLY LEFT BLANK

Sub-Section G Operating Limitations and Information

AMC T 1505 a) (Interpretative Material)

Speeds (EAS) determined from structural limitations should be suitably converted.

AMC T 1529 (Interpretative Material)

[It is recommended that maintenance manuals and other supporting documents are produced using the format of ATA Specification 100.]

Manuals containing the information essential for servicing and maintaining the engine, propeller and rotor should also be provided unless the information is contained within the gyroplane maintenance manual.

Note that the inspection techniques should include procedures to check that the primary structure, controls, rotor and propeller are free from cracks, corrosion or visible damage.

AMC T 1542 (Interpretative Material)

Limitations essential to the safe operation of the gyroplane should include:

- a) **Airspeed limitations.** The never-exceed speed V_{NE} .
- b) [If feasible, the airspeed indicator should be marked as follows, with the markings located at the corresponding indicated airspeeds:
 - i) A red radial or red line at V_{NE} (power-on);
 - ii) For the caution range, a yellow arc;
 - iii) For the safe operating range, a green arc.]
 - c) **Powerplant limitations.** Such pressure, temperature, rpm and other limitations as may have been determined under T 1521.
 - d) [For each required powerplant instrument, as appropriate to the type of instruments the following should be marked:
 - i) A red radial line or red line for each maximum and if applicable, minimum safe operating limit;
 - ii) A green arc or green line not extending beyond the maximum and minimum safe limits for each normal operating range;
 - iii) A yellow arc or a yellow line for each take-off and precautionary range; and
 - iv) Red arcs or red lines for each engine range that is restricted because of excessive vibration stresses.

Otherwise placards must be provided.]

- e) **Reduction in normal g.** A placard, stating that manoeuvres involving a deliberate reduction in normal g shall be avoided, must be positioned so that it is in full view of the pilot(s).

AMC T 1581 b) (Interpretative Material)

- a) This should include advice on the hazards associated with low g manoeuvres. This advice should address which sorts of manoeuvre can lead to a reduction in normal g and how to avoid them.

- b) The Pilot's Handbook should also contain guidance material to advise the pilot that, in the event of a change in the vibration characteristics of the gyroplane, the primary structure, controls and propeller of the gyroplane should be inspected for signs of cracks, damage etc. in accordance with the procedures specified in the maintenance manual.
- c) Advice should be included on any conditions which can lead to engine stoppage at low fuel levels.
- d) [If appropriate, advice of the inadvisability of flight in rain and the adverse effects on performance due to leading edge erosion, accumulation of dead insects and other "surface finish" degrading contaminants on the rotor and propeller blades should be given.

AMC T 1583 b) 3) (Interpretative Material)

The following information is needed:

- i) maximum and minimum occupant weight for each seat;
- ii) maximum baggage weight and any applicable restrictions on occupant loading when baggage is carried;
- iii) fuel load limitations including any restrictions on occupant weights when full fuel is carried;
- iv) removable ballast weight (if required) and conditions for its use;
- v) any loading restrictions for solo operation, e.g. aircraft to be flown solo from the front seat only.]

AMC T 1585 f) 3) and f) 4) (Interpretative Material)

V_{MIN} , $V_{MC (power-off)}$ and/or $V_{MC (power-on)}$ may be below the normal operating range of the airspeed indicator on some gyroplanes (typically for a pusher configuration). In this case, compliance with T 1585 f) 3) and f) 4) can be shown by estimating the speed. This estimate could be made by carrying out the test in zero wind and measuring ground speed by GPS.

Sub-Section J Propellers

AMC T 1917 (Interpretative Material)

Propellers made from composite materials, or which incorporate provision for ground adjustment of pitch, or which have novel features, may be required to be subjected to a proof load test, in which case the loads to be applied and the method of application shall be agreed in advance with the CAA.

[AMC T 1935 (Interpretative Material)]

The pull load should be twice the maximum centrifugal load multiplied by the ultimate factor. No other material factors of T 613 need apply. However, the other special factors of Subpart D do still apply (e.g. casting factor T 621).

INTENTIONALLY LEFT BLANK