

**UNCLASSIFIED**

**AD 407 801**

**DEFENSE DOCUMENTATION CENTER**

FOR

**SCIENTIFIC AND TECHNICAL INFORMATION**

**CAMERON STATION, ALEXANDRIA, VIRGINIA**



**UNCLASSIFIED**

NOTICE: When government or other drawings, specifications or other data are used for any purpose other than in connection with a definitely related government procurement operation, the U. S. Government thereby incurs no responsibility, nor any obligation whatsoever; and the fact that the Government may have formulated, furnished, or in any way supplied the said drawings, specifications, or other data is not to be regarded by implication or otherwise as in any manner licensing the holder or any other person or corporation, or conveying any rights or permission to manufacture, use or sell any patented invention that may in any way be related thereto.

63-4-2

**GMIIIID**

**GENERAL DYNAMICS | CONVAIR**

CATALOGED BY DDC  
AS AD No. 407801

Report No. 8926-161

Material - Transparency - Plastic - Plexiglas 55

Static and Fatigue Strength

E. Schiff, J. P. McNelly, W. E. Wise

407801

30 September 1957

DDC  
RECEIVED  
JUN 12 1963  
RECEIVED  
TISIA B

Published and Distributed  
under  
Contract AF33(657)-8926



GENERAL DYNAMICS | CONVAIR

MODEL  
DATE

PAGE  
REPORT NO.

Report No. 8926-161

Material - Transparency - Plastic - Plexiglas 55

Static and Fatigue Strength

Abstract:

Static tensile and notched tensile, tensile fatigue, crack propagation, edge attachment and shear-out tests were made with biaxially stretched (70% approx.) Plexiglas 55 supplied by the Swedlow Plastics Co., Los Angeles, Calif. The test data resulting from tests at -50, 75 and 195°F are given in tabulations and charts.

Reference: Schiff, E., McNelly, J. P., Wise, W. E.,  
"Plexiglass 55 - Physical Properties -  
Static and Fatigue Tests," General Dynamics/  
Convair Report SL 56-164, San Diego, California,  
30 September 1957. (Reference attached).



ANALYSIS  
PREPARED BY E. Schiff  
CHECKED BY W. E. Wise  
REVISED BY

CONVAIR  
A DIVISION OF GENERAL DYNAMICS CORPORATION  
SAN DIEGO

PAGE 1  
REPORT NO. 56-164  
MODEL F-102A  
DATE 30 Sept 1957

REPORT NO. 56-164  
PLEXIGLAS 55 - PHYSICAL PROPERTIES  
STATIC AND FATIGUE TESTS  
MODEL F-102A

REFERENCES:

- (a) Federal Specification LP 406 b, "Plastics, Organic: General Specifications, Test Methods", dated 27 September 1951.
- (b) Convair Specification ZM-8-104, "Specification for Canopy and Windshield Materials Development".

OBJECT:

To determine various physical properties of Plexiglas 55, biaxially stretched approximately 70%, for design information purposes and to provide data for the selection of minimum acceptable properties for a procurement specification.

TEST SPECIMENS:

All stretched test specimens were from a single lot of Plexiglas 55 stretched and furnished by Swedlow Plastics Company. After stretching the material, the vendor subjected it to the same heat cycle as a production F-102A canopy panel. Two shrink-back specimens cut from this sheet and shrunk back gave an average stretch percentage of 66.2. As-cast Plexiglas 55 was also furnished by Swedlow Plastics Company.

Specimen configurations were as follows:

Static tensile tests - The 75°F and 194°F specimens were standard tensile coupons in accordance with Reference (a); the -50°F specimens were modified as shown in Figure 1 to cause failure to occur at the center, since they otherwise often failed at the grips.

Static notched tensile tests - These were made as shown in Figures 2 and 3.

Tensile fatigue tests - The specimen shown in Figure 1 was used at 75°F and 194°F; the -50°F specimens were modified as shown in Figure 4, to cause failure at the center.

Crack propagation tests - Standard 2 inch x 6 inch specimens were used, in accordance with Reference (b). See Figure 14.

Edge attachment tests - Convair 8-07142 specimens were made by Swedlow Plastics Company, per Reference (b). See Figure 5.

Shear-out tests - The specimen is shown in Figure 6.

**ANALYSIS**  
**PREPARED BY** E. Schiff  
**CHECKED BY** W. E. Wise  
**REVISED BY**

**C O N V A I R**  
 A DIVISION OF GENERAL DYNAMICS CORPORATION  
 SAN DIEGO

**PAGE 2**  
**REPORT NO.** 56-164  
**MODEL** F-102A  
**DATE** 30 Sept 1957

TEST PROCEDURES:

Static tensile tests - Reference (a) was followed, except that the load rate was changed to .02 inch per minute, to more closely approach the estimated load rate in service. Five specimens were run at each of 3 temperatures: 75°F, 194°F and -50°F.

Static notched tensile tests - The same procedure as for unnotched tensile tests was followed. Ten specimens each of stretched and as-cast Plexiglas 55 were tested at 75°F.

Tensile fatigue tests - A Triplett and Barton fatigue machine was used to load the specimens, at a rate of 15 cycles per minute. Four points were obtained on an S-N curve at 194°F. Five specimens were run at 75°F at 7,000 psi for a minimum of 20,000 cycles, and five were run at -50°F at 10,000 psi for a minimum of 20,000 cycles.

Crack propagation tests - Reference (a) was followed, with load rate adjusted to fail the specimen in 3 to 5 minutes. Five specimens were tested at each of 3 temperatures: 75°F, 194°F and -50°F.

Edge attachment tests - A set of holding fixtures simulating the canopy edge attachment were used. This loaded the specimen eccentrically, similar to the way the actual canopy frame loads the plastic panel. Five specimens were tested at each of 3 temperatures: 75°F, 194°F and -50°F.

Shear-out tests - The specimens were loaded in double shear, using a .186 inch diameter pin. All tests were at 75°F. An attempt was made to cause a shear failure, by varying the edge distance.

RESULTS:

Results of all tests are given in Tables I through V, and failed specimens are shown in Figures 8 through 16. The edge attachment specimens all failed initially by shearing the orlon-acrylic impregnate ledge. The 75°F specimens were reloaded after this failure, until complete tensile failure through the Plexiglas occurred.

The shear-out tests were halted after edge distances as low as 1 d failed to produce a shear failure; all specimens failed in tension. Failing loads were as follows:

<u>Specimen</u>	<u>Edge Distance</u>	<u>Ultimate - Lbs.</u>
257C-1	2 d	1520
257A-1	1.5 d	1225
257A-2	1 d	750

An S-N curve of tensile fatigue data at 194°F is given in Figure 7.

NOTE:

The test data from which this report was prepared are recorded in Structures Test Laboratory Data Book No. 4005, pages 5 through 9.

ANALYSIS  
PREPARED BY E. Schiff  
CHECKED BY W. E. Wise  
REVISED BY

**C O N V A I R**  
A DIVISION OF GENERAL DYNAMICS CORPORATION  
SAN DIEGO

PAGE 3  
REPORT NO. 56-164  
MODEL F-102A  
DATE 30 Sept 1957

TABLE INDEX

<u>TABLE NO.</u>	<u>TITLE</u>	<u>PAGE NO.</u>
I	Static Tensile Tests - Stretched Plexiglas 55 - (Swedlow Plastics Company)	4
II	Static Notched Tensile Tests - As-Cast and Stretched Plexiglas 55	5
III	Crack Propagation Tests - Stretched Plexiglas 55	6
IV	Edge Attachment Static Tensile Tests - Stretched Plexiglas 55	7
V	Tensile Fatigue Test Results - Stretched Plexiglas 55	8



TABLE I  
 STATIC TENSILE TESTS - STRETCHED PLEXIGLAS 55 - ( SWEDLOW PLASTICS COMPANY)

SPECIMEN NO.	TEST TEMP. F.	TEST SPEED IN./MIN.	SPECIMEN		LOAD LBS.	ULTIMATE STRESS P.S.I.	REMARKS
			T. IN.	W. IN.			
257B - 17	76	.02	.357	.751	3180	11900	
257B - 16	75		.357	.750	3200	11950	
459D - 11	75		.359	.745	3130	11720	
459D - 12	75		.361	.745	3135	11650	
459D - 13	75		.356	.745	3195	12060	
459D - 5	194		.352	.745	AV.	11856	
459D - 7	194		.354	.746	1220	4660	
459D - 8	194		.355	.745	1100	4170	
459D - 9	194		.357	.744	1120	4240	
459D - 10	194		.358	.745	1180	4440	
459A - 15	-50		.368	.500	1140	4270	
459A - 17	-50		.356	.500	AV.	4356	
459A - 18	-50		.355	.498	3920	21293	
459A - 19	-50		.355	.500	3300	18581	
459A - 20	-50	.02	.356	.498	3410	19266	
					3430	19313	
					3090	17467	
					AV.	19154	

TABLE II  
 STATIC NOTCHED TENSILE TESTS - AS-CAST AND STRETCHED PLEXIGLAS 55

MATERIAL	SPECIMEN NO.	TEST TEMP. F.	TEST SPEED IN/MIN.	SPECIMEN		ULTIMATE	
				T. IN.	W. IN.	LOAD LBS.	STRESS P.S.I.
STRETCHED PLEX 55	257A-1	76	.02	.233	.516	600	4990
	2	77		.235	.519	920	7480
	3	77		.237	.517	900	7350
	4	76		.237	.516	960	7850
	5	76		.238	.513	940	7700
	6	75		.238	.523	780	6260
	7	75		.239	.525	1040	8290
STRETCHED PLEX 55	459D-1	75	.228	.509	775	6670	
	2	75	.229	.510	1010	8650	
	3	76	.230	.508	1075	9200	
AS-CAST PLEX 55	ACP55-1	75	.330	.509	Av.	7444	
	2	75	.330	.497	405	2410	
	3	75	.331	.506	370	2260	
	4	74	.330	.510	330	1970	
	5	73	.330	.509	285	1690	
	6	73	.333	.504	170	1010	
	7	74	.338	.508	230	1370	
	8	74	.330	.506	235	1370	
	9	73	.331	.508	215	1290	
	10	74	.330	.508	205	1220	
AS-CAST PLEX 55			.02			200	1190
					Av.	1578	

RIAVMOC  
 ODEGNI MAZ  
 1-ET MROF

TABLE III

CRACK PROPAGATION TESTS - STRETCHED PLEXIGLAS 55

Specimen No.	Temp. °F	Load Rate lb/min	T in.	X in.	P lbs.	K lb/in.
257	-1	600	.350	.35	2600	2820
	2		.351	.33	2750	2860
	3		.365	.33	2850	2670
	4		.355	.40	2600	2980
	5		.351	.55	2850	3060
				AV.	2878	
459C	-6		.362	.84	2590	4561
	7	194	.362	1.00	2370	4951
	8		.363	.83	2650	4617
	9		.368	.62	2840	4013
	10		.371	.64	2780	3981
				AV.	4425	
459D	-1	400	.345	.250	1560	1424
	2		.345	.240	1645	1466
	3		.347	.245	1650	1480
	4		.348	.250	1740	1575
	5		.350	.230	1540	1331
				AV.	1455	

PAGE 6  
 REPORT NO. 56-164  
 DATE 30 September 1957



**TABLE V**  
**TENSILE FATIGUE TEST RESULTS - STRETCHED PLEXIGLAS 55**

SPECIMEN NO.	TEMP. OF	WIDTH IN.	THICKNESS IN.	LOAD IN. LBS.	STRESS PSI	FAILURE CYCLES	REMARKS
257 D 30	194	.504	.355	716	3915	182	
29		.501	.354	701	4088	288	AV. 415
28		.500	.354	701	3976	406	
C 25		.494	.356	701	3987	784	
24		.498	.356	621	3499	1796	
26		.501	.357	621	3475	414	AV. 918
29		.496	.356	621	3513	544	
30		.500	.356	619	3438	863	
27		.498	.357	601	3383	2203	AV. 1511
23		.504	.357	611	3402	1469	
28		.501	.357	604	3380	18361	No Failure
21		.499	.357	533	2996	16807	No Failure
19		.502	.357	536	2992	9931	
22		.496	.357	529	2996	624	AV. 4499
17		.498	.359	534	2988	2943	
20		.500	.357	535	3000	55510	No Failure
18		.499	.358	535	2995	16372	No Failure
B 2	75	.500	.356	1246	7001	22017	"
10		.500	.357	1250	7003	24961	"
5		.501	.353	1240	7003	36584	"
8		.501	.357	1250	6992	22835	"
7		.505	.354	1250	6992	22301	"
13	-50	.350	.358	1254	9997	21001	"
14		.348	.358	1250	10036	21115	"
11		.350	.357	1250	10000	24312	"
15		.349	.357	1246	9994	23734	"
9		.351	.357	1252	10005	20494	"

SAN DIEGO

DA 73-1

ANALYSIS  
 PREPARED BY E. Schiff  
 CHECKED BY W. E. Wise  
 REVISED BY

**C O N V A I R**  
 A DIVISION OF GENERAL DYNAMICS CORPORATION  
 SAN DIEGO

PAGE 9  
 REPORT NO. 56-164  
 MODEL F-102A  
 DATE 30 Sept 1957

FIGURE INDEX

<u>FIGURE NO.</u>	<u>PHOTO NO.</u>	<u>TITLE</u>	<u>PAGE NO.</u>
1		Tensile Fatigue Specimen - Stretched Plexiglas 55	10
2		Notched Static Tensile Specimen - Stretched Plexiglas 55	11
3		Notched Static Tensile Specimen - As-Cast Plexiglas 55	12
4		Tensile Fatigue Specimen - Stretched Plexiglas 55	13
5		Specimen - Test, Edge Attachment, Canopy Window	14
6		Shear-out Specimen - Stretched Plexiglas 55	15
7		S-N Curve for Stretched Plexiglas 55 - Test Temperature 194°F	16
8	23754	Static Tensile Failure 75°F	17
9	23753	Static Tensile Failure 194°F	18
10	23755	Static Tensile Failure -50°F	19
11	23757	Static Notched Tensile Failure - As-Cast Plexiglas 55	20
12	23756	Static Notched Tensile Failure - Stretched Plexiglas 55	21
13	23752	Tensile Fatigue Specimens - Stretched Plexiglas 55	22
14	23760	Crack Propagation Specimens - Stretched Plexiglas 55	23
15	23759	Edge Attachment Specimens - Stretched Plexiglas 55	24
16	23758	Shear-out Specimens - Stretched Plexiglas 55	25

ANALYSIS  
PREPARED BY E. Schiff  
CHECKED BY W. E. Wise  
REVISED BY

CONVAIR  
A DIVISION OF GENERAL DYNAMICS CORPORATION  
SAN DIEGO

PAGE 10  
REPORT NO. 56-164  
MODEL F-102A  
DATE 30 Sept 1957

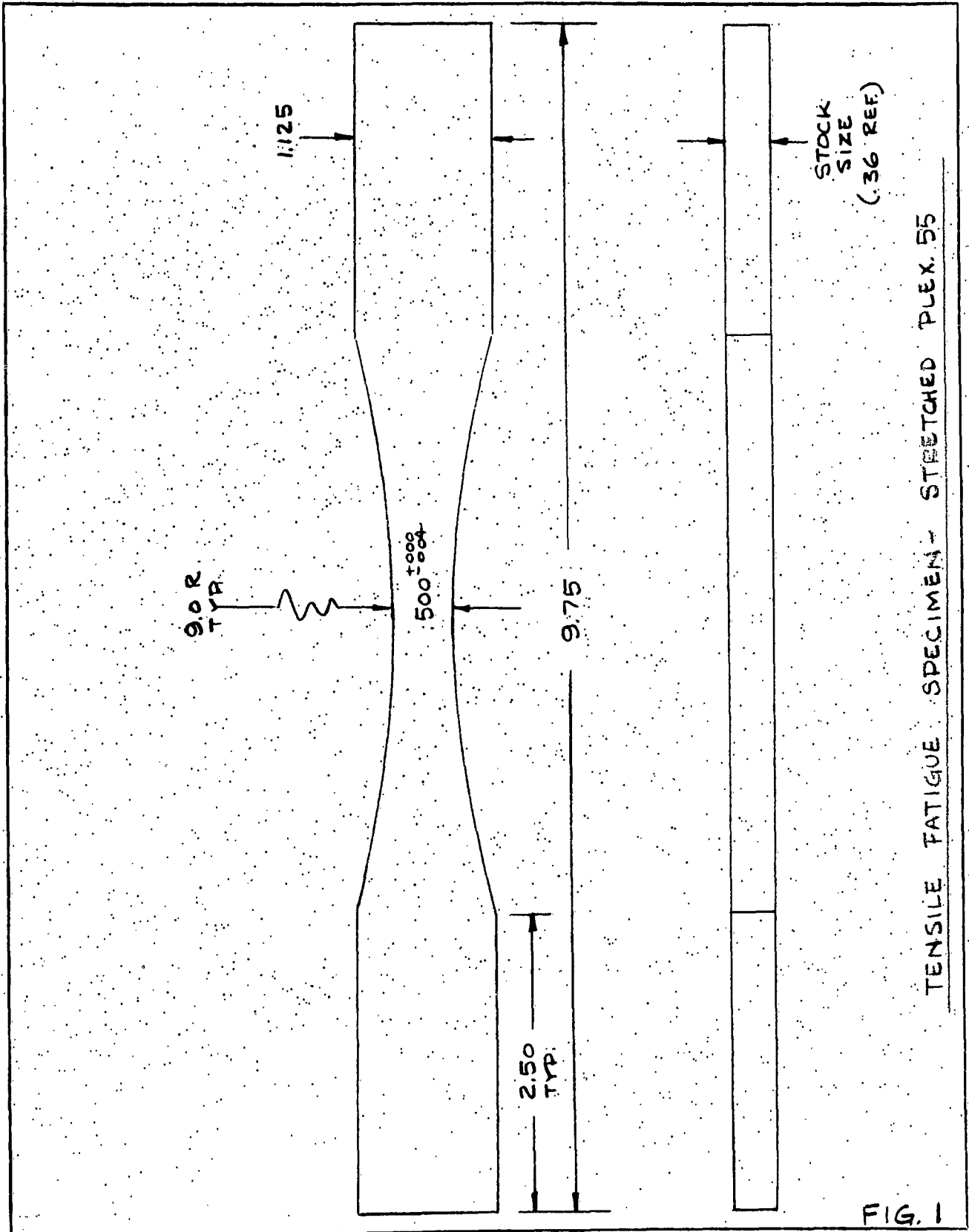

TENSILE FATIGUE SPECIMEN - STRETCHED PLEX. 55

FIG. 1

ANALYSIS  
PREPARED BY E. Schiff  
CHECKED BY W. E. Wise  
REVISED BY

CONVAIR  
A DIVISION OF GENERAL DYNAMICS CORPORATION  
SAN DIEGO

PAGE 11  
REPORT NO. 56-164  
MODEL F-102A  
DATE 30 Sept 1957

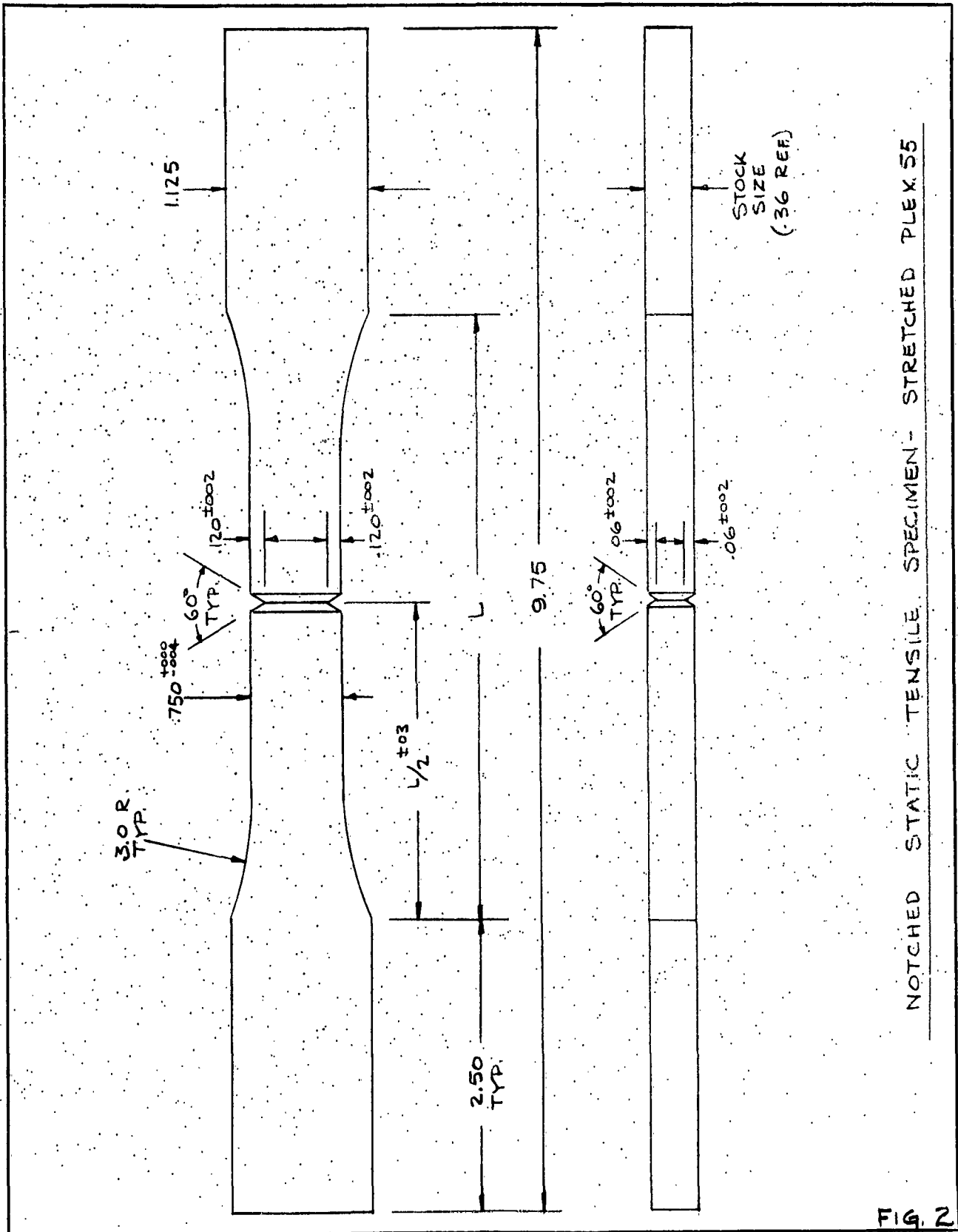

NOTCHED STATIC TENSILE SPECIMEN - STRETCHED PLEX 55

FIG. 2



ANALYSIS  
PREPARED BY E. Schiff  
CHECKED BY W. E. Wise  
REVISED BY

CONVAIR  
A DIVISION OF GENERAL DYNAMICS CORPORATION  
SAN DIEGO

PAGE 12  
REPORT NO. 56-164  
MODEL F-102A  
DATE 30 Sept 1957

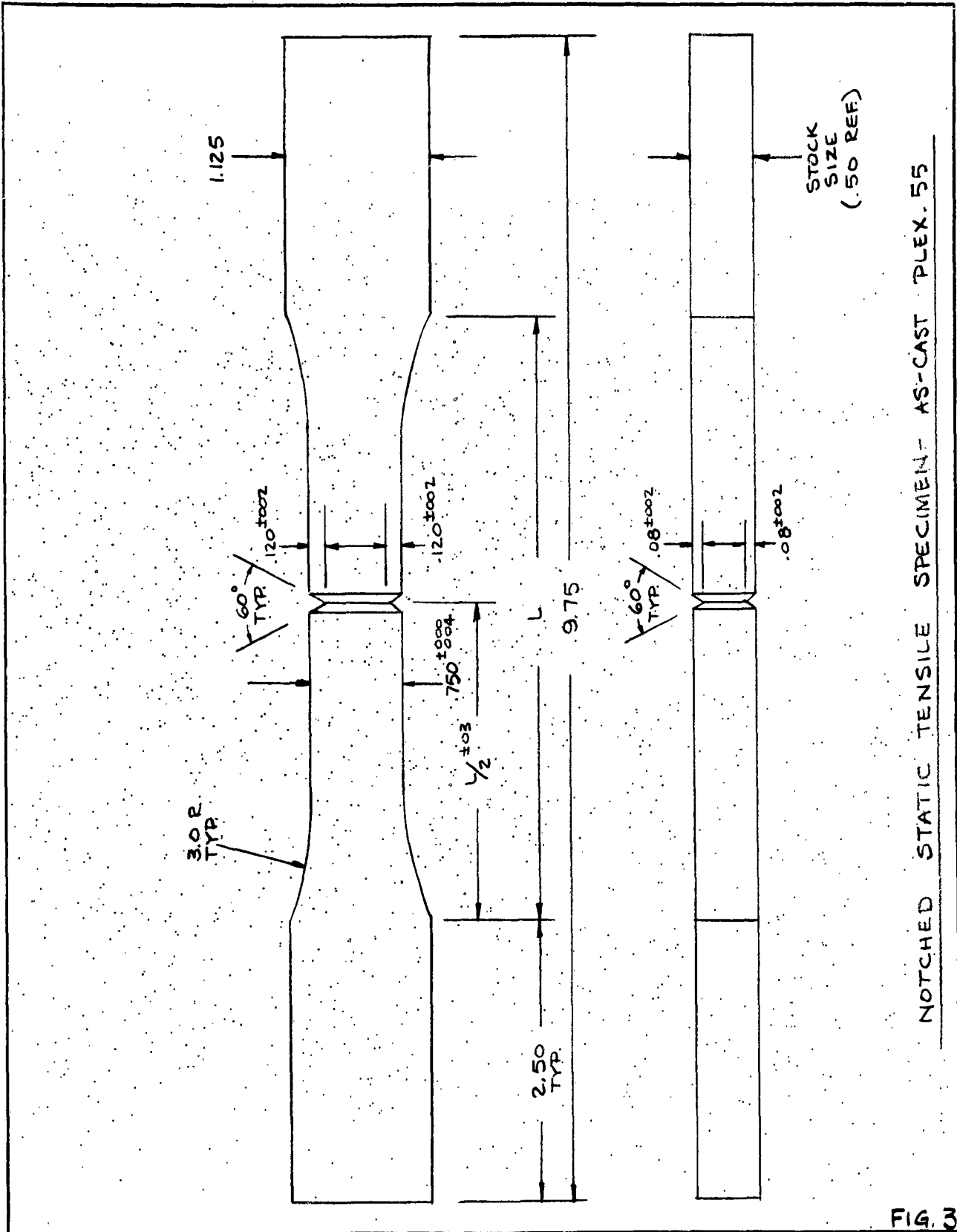
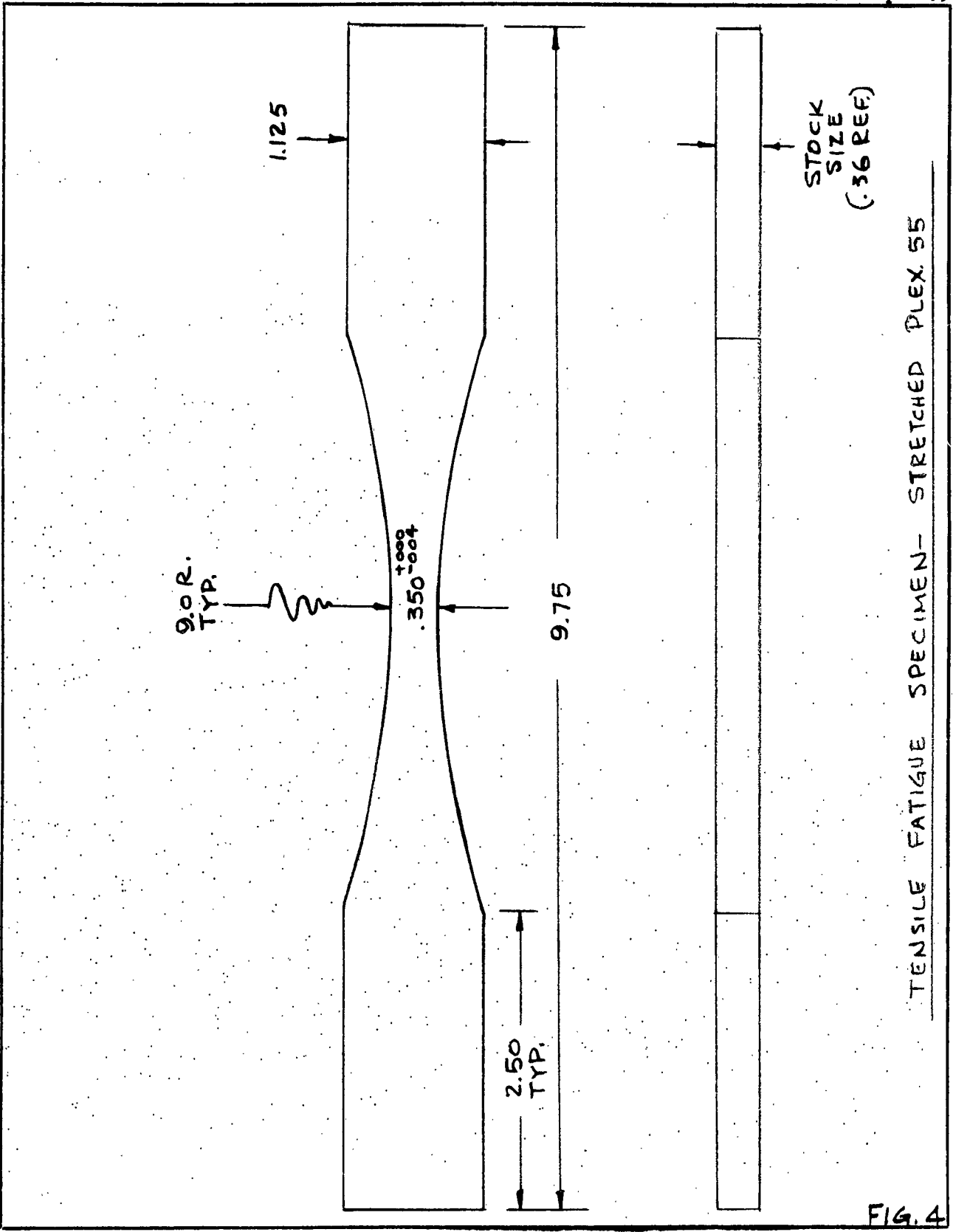

FIG. 3

ANALYSIS  
PREPARED BY E. Schiff  
CHECKED BY W. E. Wise  
REVISED BY

CONVAIR  
A DIVISION OF GENERAL DYNAMICS CORPORATION  
SAN DIEGO

PAGE 13  
REPORT NO. 56-164  
MODEL F-102A  
DATE 30 Sept 1957



TENSILE FATIGUE SPECIMEN - STRETCHED PLEX 55

FIG. 4

ANALYSIS  
PREPARED BY E. Schiff  
CHECKED BY W. E. Wise  
REVISED BY

CONVAIR  
A DIVISION OF GENERAL DYNAMICS CORPORATION  
SAN DIEGO

PAGE 14  
REPORT NO. 56-164  
MODEL F-102A  
DATE 30 Sept 1957

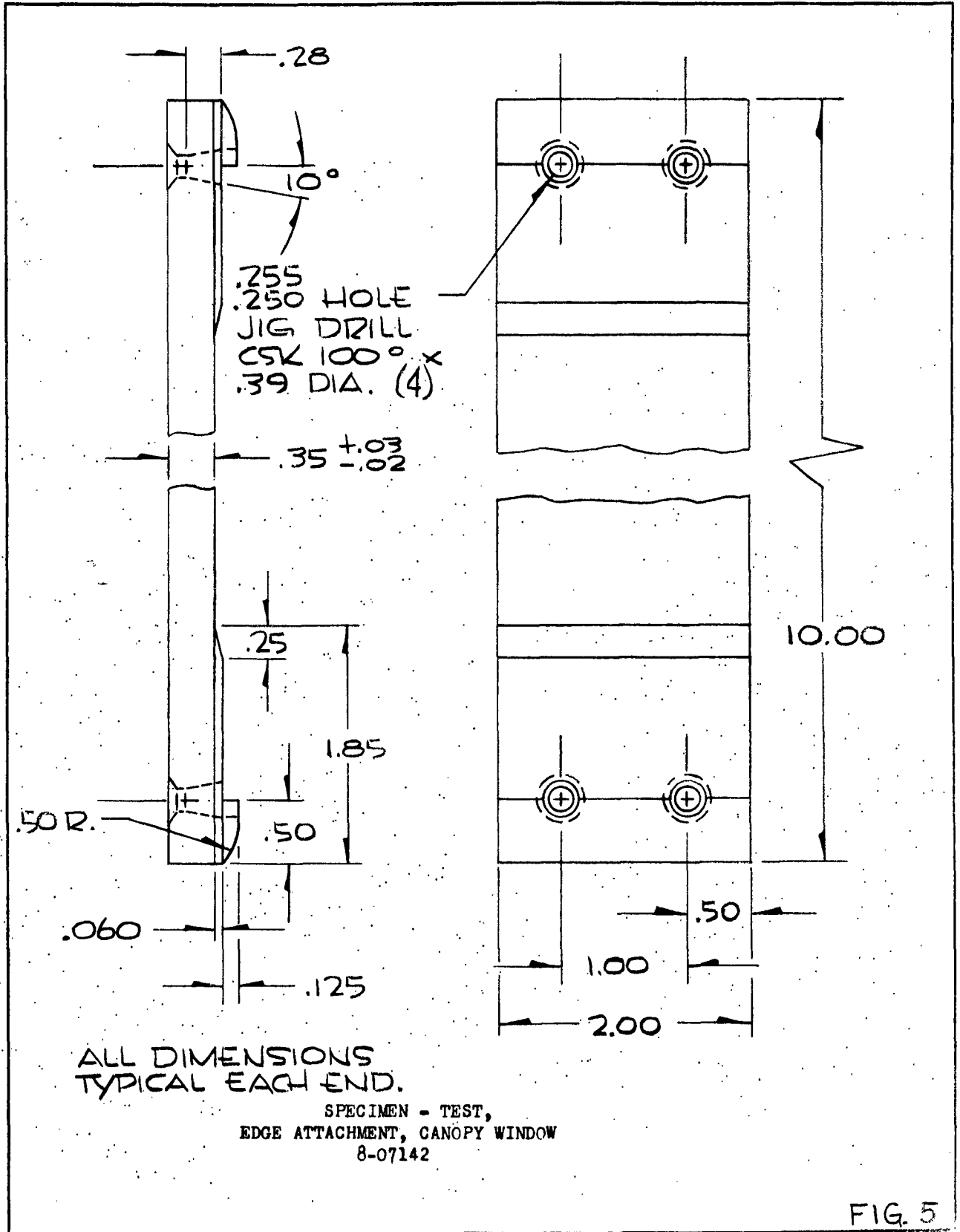

ANALYSIS  
PREPARED BY E. Schiff  
CHECKED BY W. E. Wise  
REVISED BY

CONVAIR  
A DIVISION OF GENERAL DYNAMICS CORPORATION  
SAN DIEGO

PAGE 15  
REPORT NO. 56-164  
MODEL F-102A  
DATE 30 Sept 1957

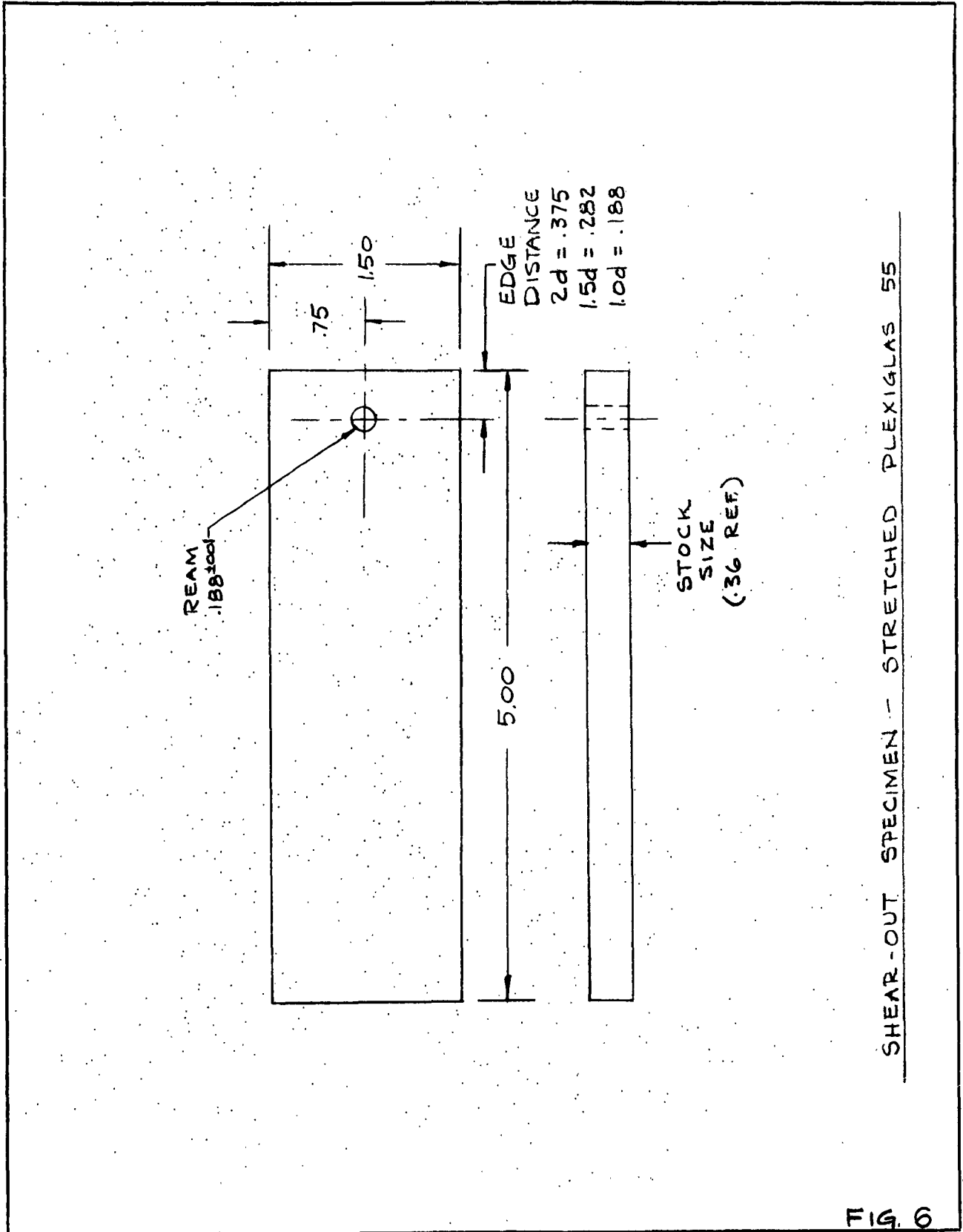

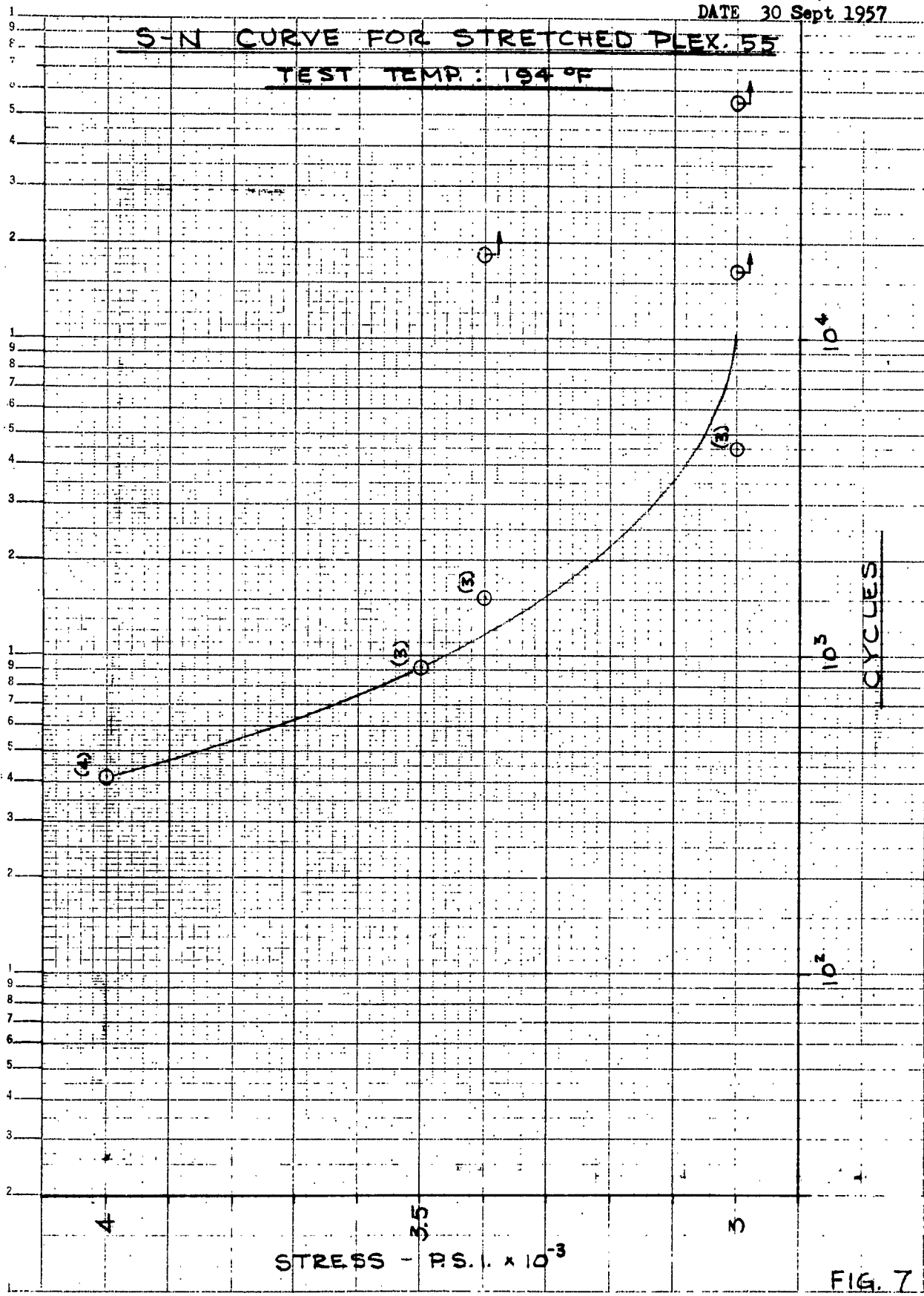

ANALYSIS  
PREPARED BY E. Schiff  
CHECKED BY W. E. Wise  
REVISED BY

**C O N V A I R**  
A DIVISION OF GENERAL DYNAMICS CORPORATION  
SAN DIEGO

PAGE 17  
REPORT NO. 56-164  
MODEL F-102A  
DATE 30 Sept 1957

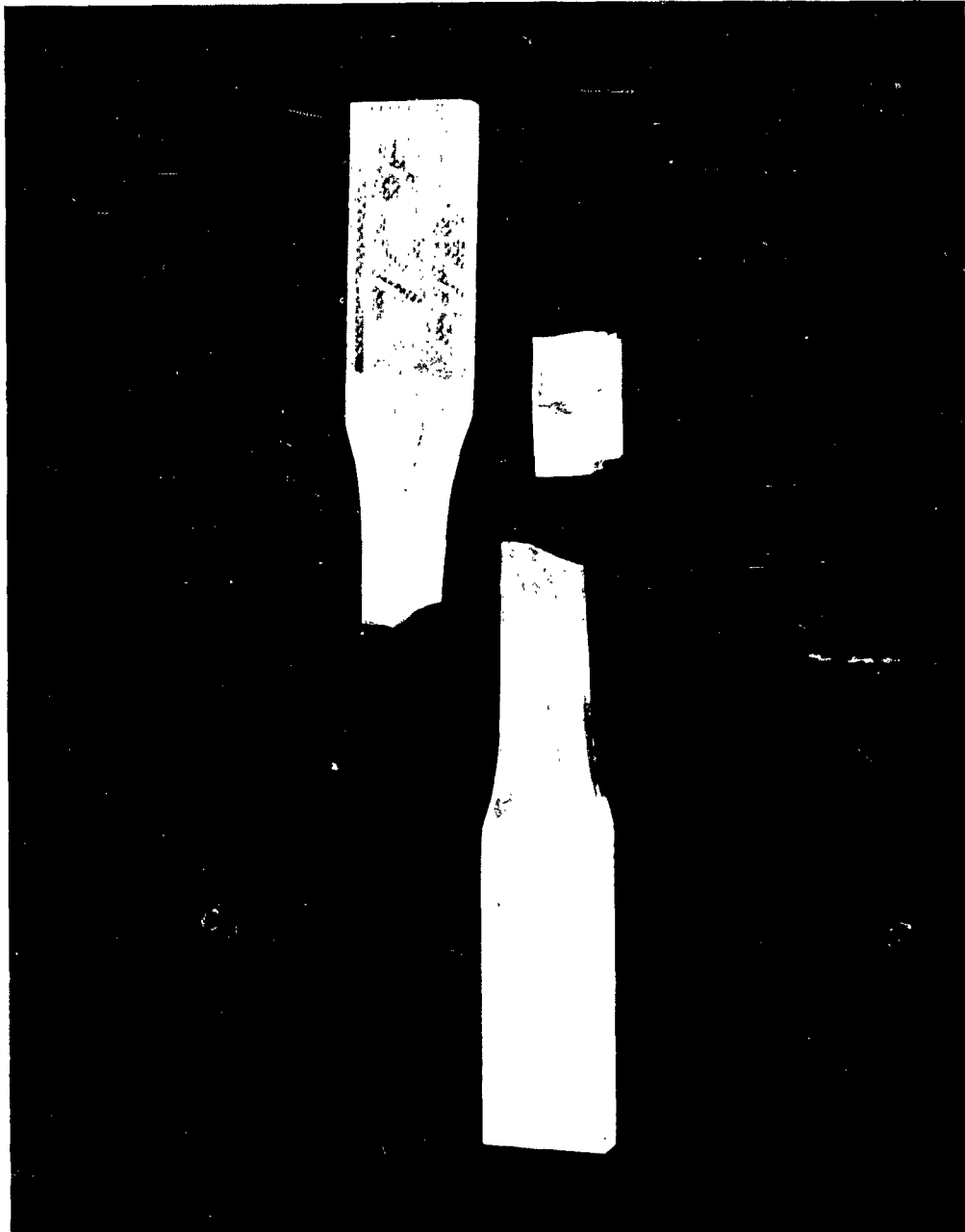

Figure 8 STATIC TENSILE FAILURE 75°F

**ANALYSIS**  
**PREPARED BY** E. Schiff  
**CHECKED BY** W. E. Wise  
**REVISED BY**

**CONVAIR**  
A DIVISION OF GENERAL DYNAMICS CORPORATION  
SAN DIEGO

**PAGE** 18  
**REPORT NO.** 56-164  
**MODEL** F-102A  
**DATE** 30 Sept 1957

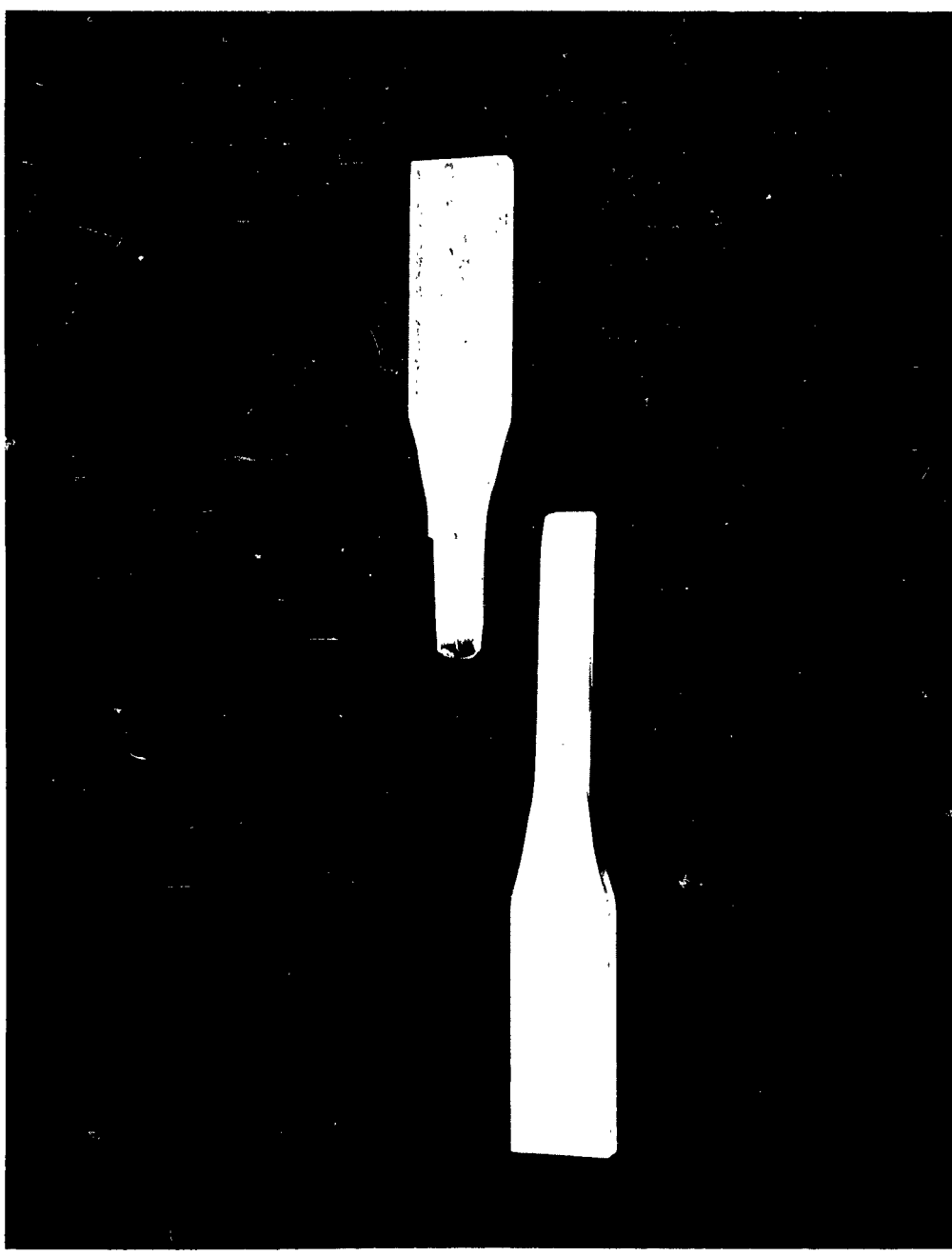

Figure 9 STATIC TENSILE FAILURE 194°F

ANALYSIS  
PREPARED BY E. Schiff  
CHECKED BY W. E. Wise  
REVISED BY

**C O N V A I R**  
A DIVISION OF GENERAL DYNAMICS CORPORATION  
SAN DIEGO

PAGE 19  
REPORT NO. 56-164  
MODEL F-102A  
DATE 30 Sept 1957

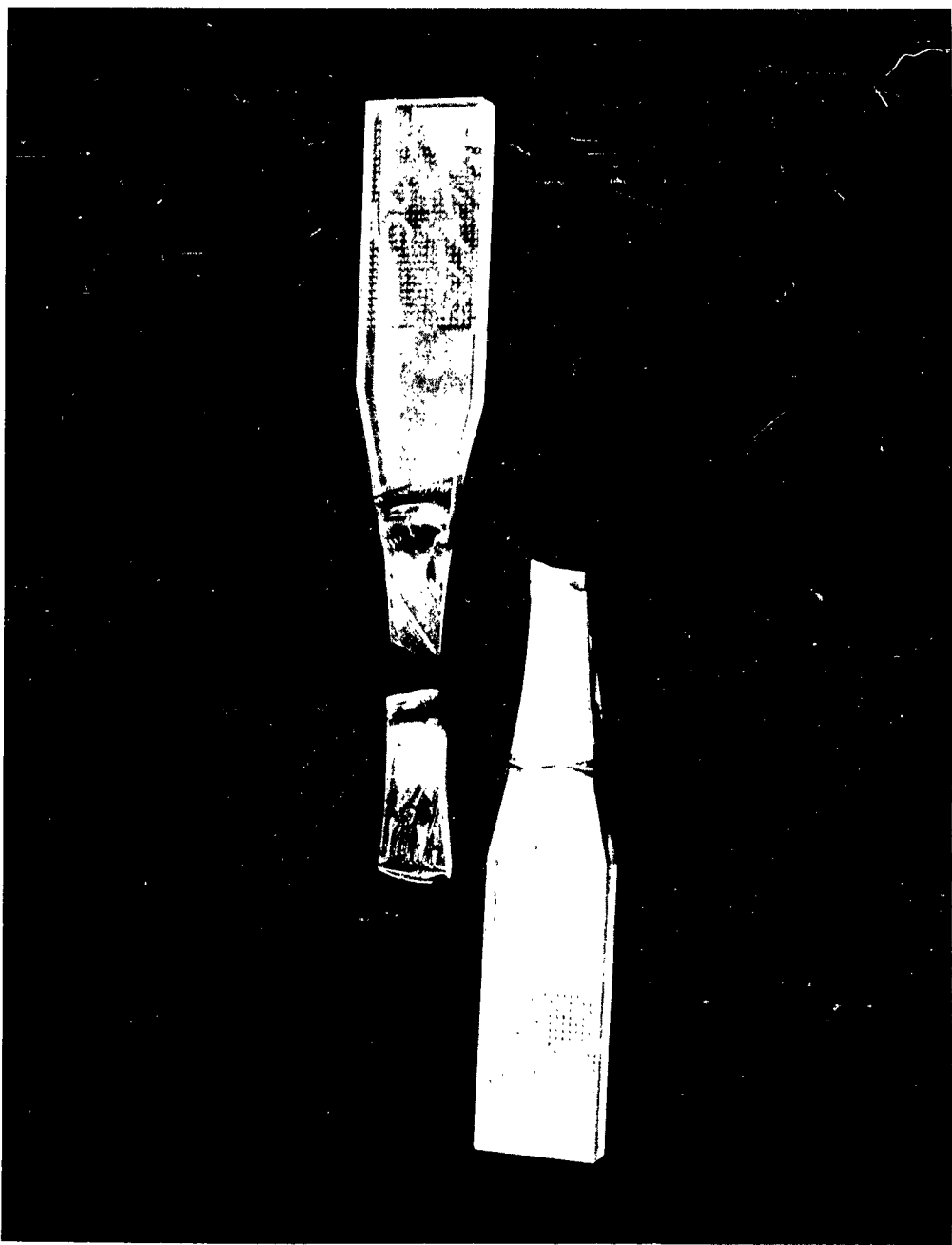

Figure 10 STATIC TENSILE FAILURE -50°F



**ANALYSIS**  
**PREPARED BY** E. Schiff  
**CHECKED BY** W. E. Wise  
**REVISED BY**

**CONVAIR**  
A DIVISION OF GENERAL DYNAMICS CORPORATION  
SAN DIEGO

**PAGE** 20  
**REPORT NO.** 56-164  
**MODEL** F-102A  
**DATE** 30 Sept 1957

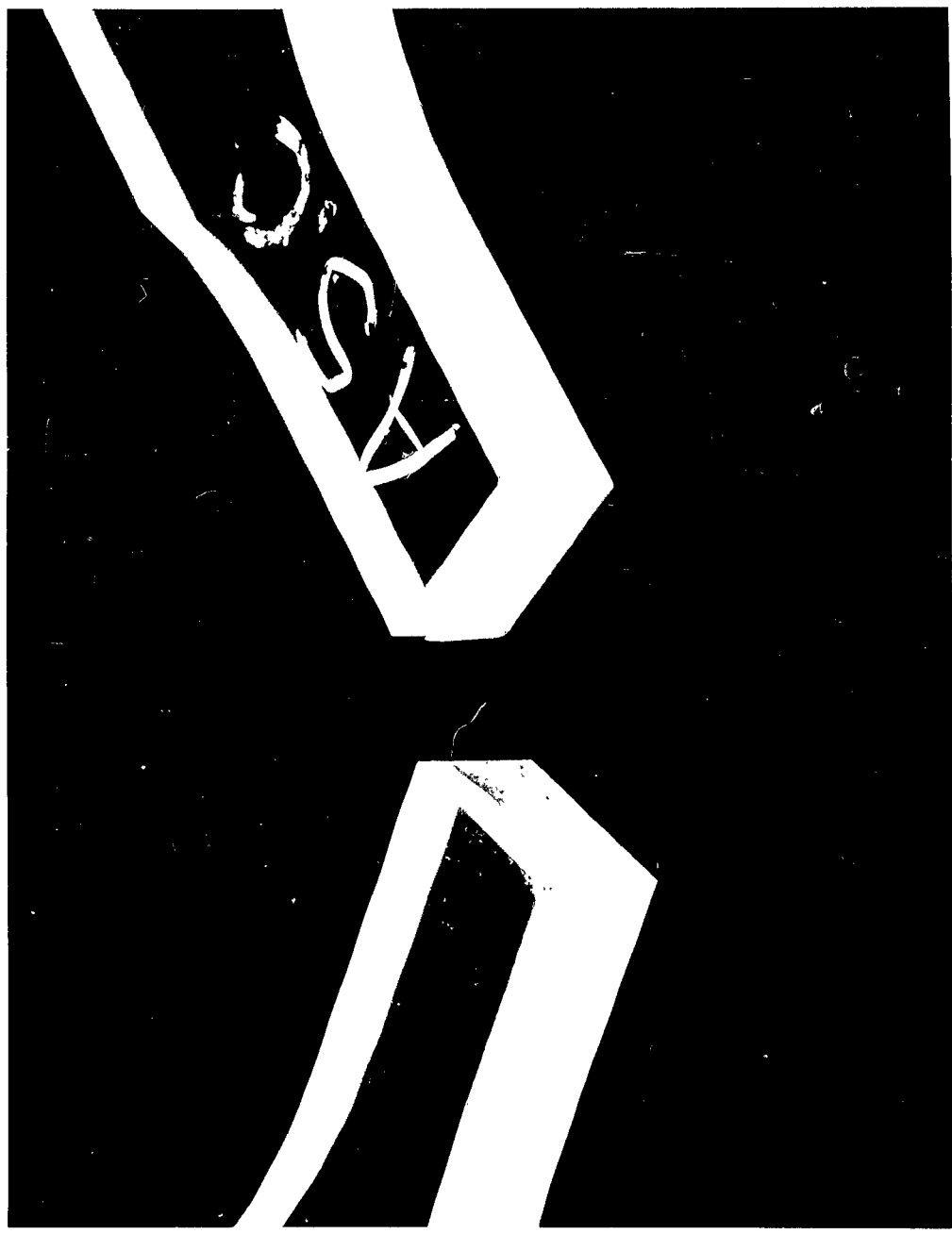

Figure 11 STATIC NOTCHED TENSILE FAILURE - AS-CAST PLEXIGLAS 55

**ANALYSIS**  
**PREPARED BY** E. Schiff  
**CHECKED BY** W. E. Wise  
**REVISED BY**

**C O N V A I R**  
A DIVISION OF GENERAL DYNAMICS CORPORATION  
SAN DIEGO

**PAGE** 21  
**REPORT NO.** 56-164  
**MODEL** F-102A  
**DATE** 30 Sept 1957



Figure 12 STATIC NOTCHED TENSILE FAILURE - STRETCHED PLEXIGLAS 55

**ANALYSIS**  
**PREPARED BY** E. Schiff  
**CHECKED BY** W. E. Wise  
**REVISED BY**

**CONVAIR**  
A DIVISION OF GENERAL DYNAMICS CORPORATION  
SAN DIEGO

**PAGE** 22  
**REPORT NO.** 56-164  
**MODEL** F-102A  
**DATE** 30 Sept 1957

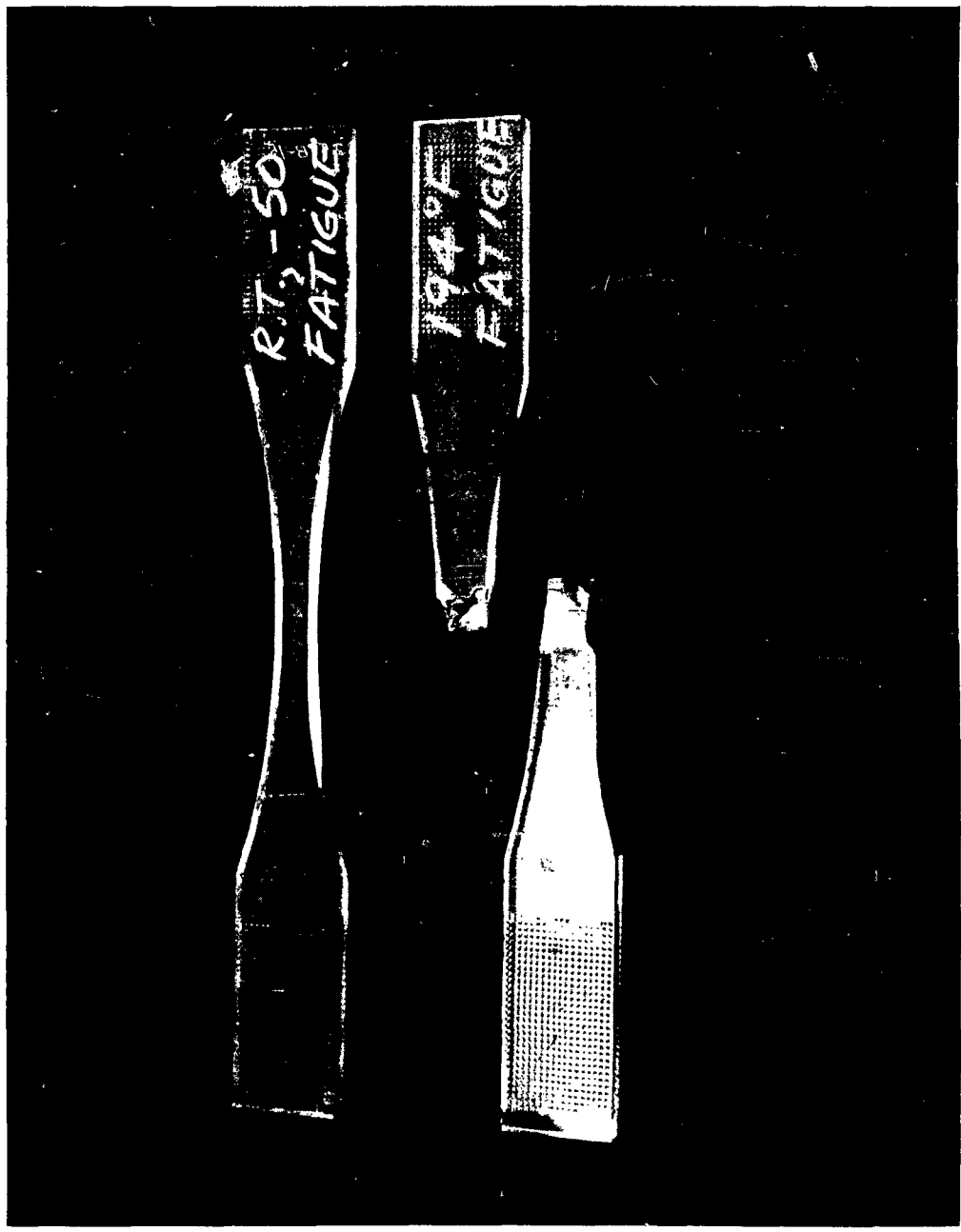

Figure 13 TENSILE FATIGUE SPECIMENS - STRETCHED PLEXIGLAS 55

ANALYSIS  
PREPARED BY E. Schiff  
CHECKED BY W. E. Wise  
REVISED BY

CONVAIR  
A DIVISION OF GENERAL DYNAMICS CORPORATION  
SAN DIEGO

PAGE 23  
REPORT NO. 56-164  
MODEL F-102A  
DATE 30 Sept 1957

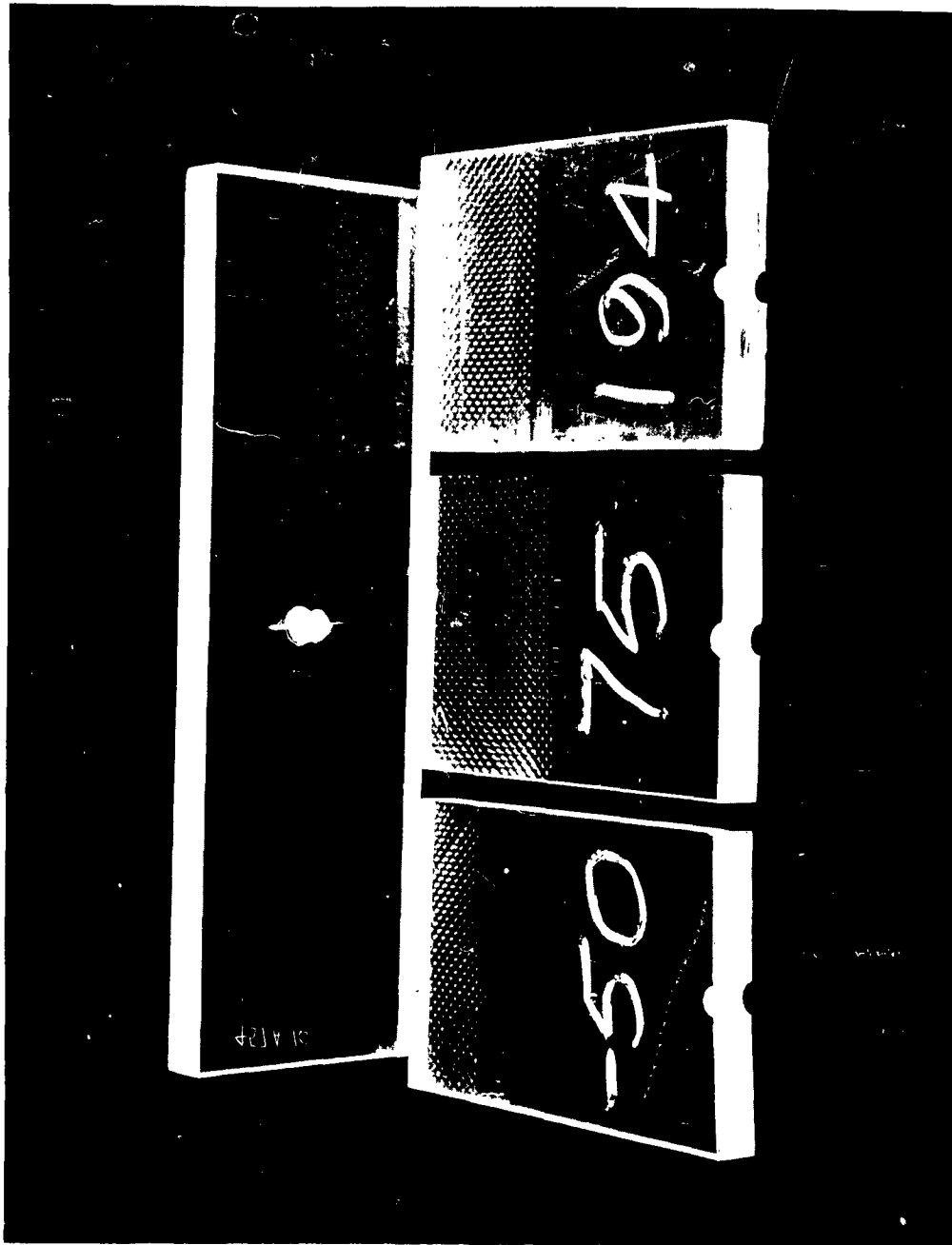

Figure 14 CRACK PROPAGATION SPECIMENS - STRETCHED PLEXIGLAS 55

ANALYSIS  
PREPARED BY E. Schiff  
CHECKED BY W. E. Wise  
REVISED BY

CONVAIR  
A DIVISION OF GENERAL DYNAMICS CORPORATION  
SAN DIEGO

PAGE 24  
REPORT NO. 56-164  
MODEL F-102A  
DATE 30 Sept 1957

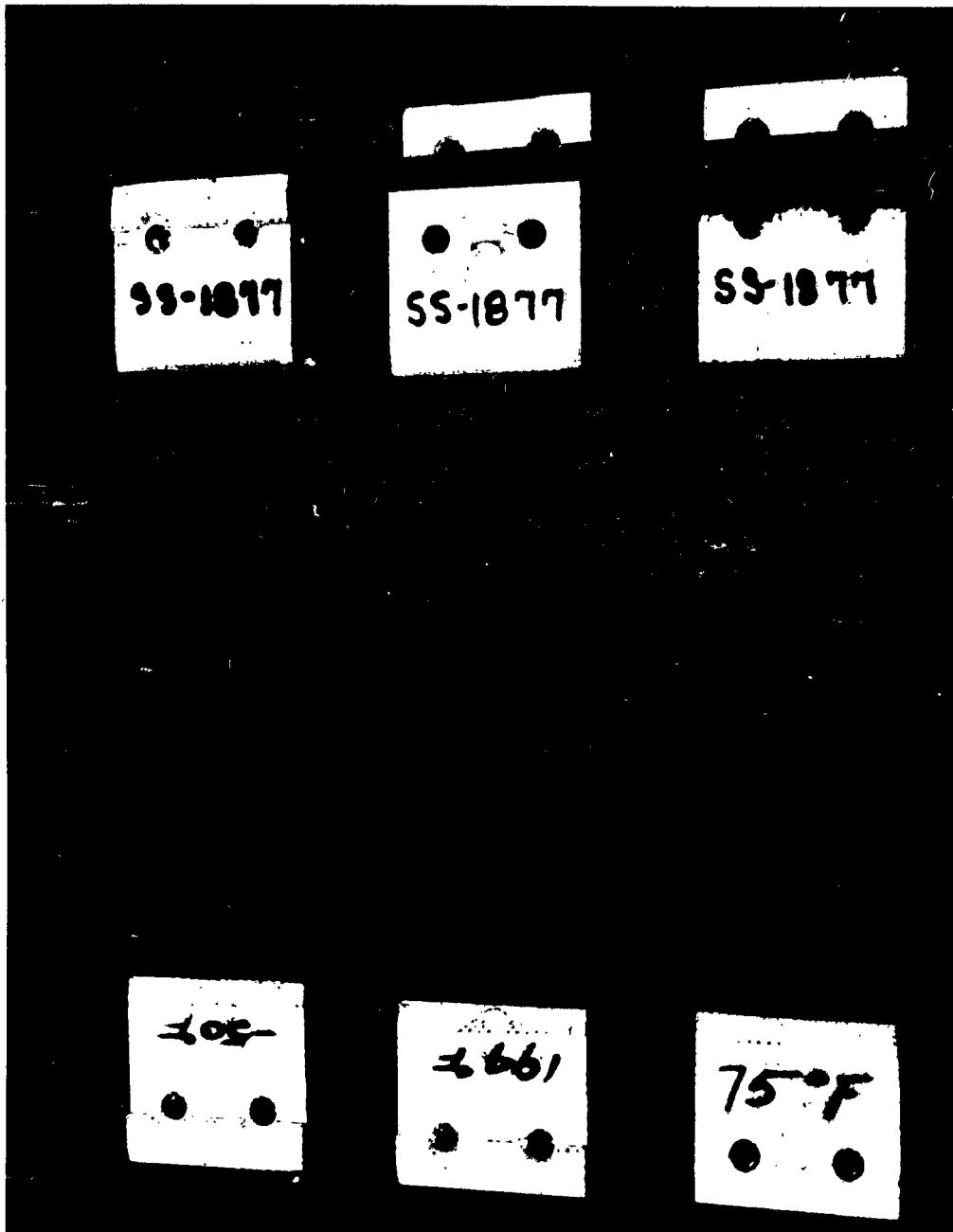

Figure 15 EDGE ATTACHMENT SPECIMENS - STRETCHED PLEXIGLAS 55

ANALYSIS  
PREPARED BY E. Schiff  
CHECKED BY W. E. Wise  
REVISED BY

**CONVAIR**  
A DIVISION OF GENERAL DYNAMICS CORPORATION  
SAN DIEGO

PAGE 25  
REPORT NO. 56-164  
MODEL F-102A  
DATE 30 Sept 1957

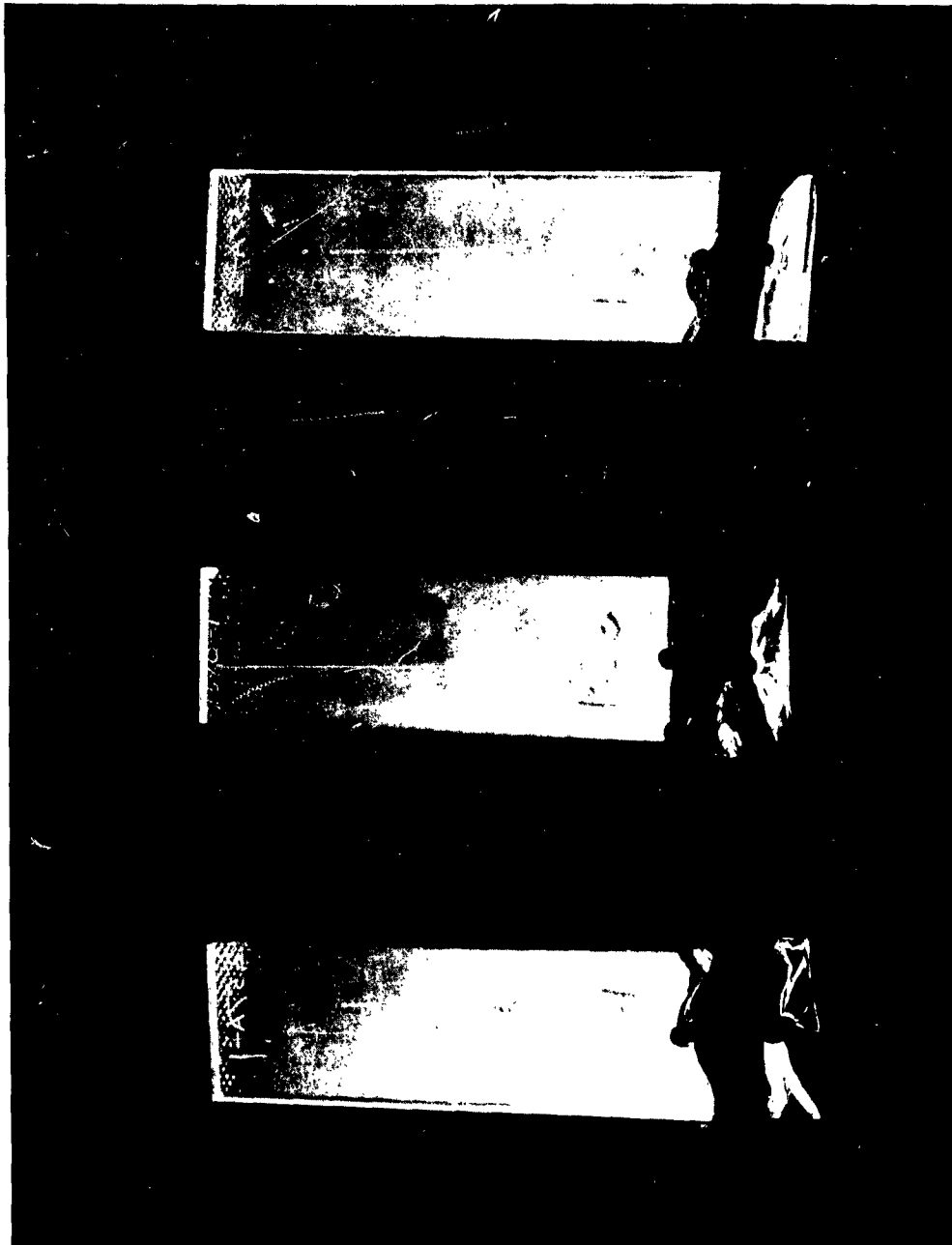

Figure 16 SHEAR-OUT SPECIMENS - STRETCHED PLEXIGLAS 55