



**US Army Corps
of Engineers®**
Engineer Research and
Development Center

ERDC
INNOVATIVE SOLUTIONS
for a safer, better world

ERDC/ITL TR-16-2

Information Technology Laboratory

Causes of Pretension Loss in High-Strength Bolts

Hussam N. Mahmoud, Santiago Rodriguez Lopez,
and Guillermo A. Riveros

June 2016



The U.S. Army Engineer Research and Development Center (ERDC) solves the nation's toughest engineering and environmental challenges. ERDC develops innovative solutions in civil and military engineering, geospatial sciences, water resources, and environmental sciences for the Army, the Department of Defense, civilian agencies, and our nation's public good. Find out more at www.erdclibrary.usace.army.mil.

To search for other technical reports published by ERDC, visit the ERDC online library at <http://acwc.sdp.sirsi.net/client/default>.

Causes of Pretension Loss in High-Strength Bolts

Guillermo A. Riveros

*Information Technology Laboratory
U.S. Army Engineer Research and Development Center
3909 Halls Ferry Road
Vicksburg, MS 39180-6199*

Hussam N. Mahmoud and Santiago Rodriguez Lopez

*Civil and Environment Eng. Department
Colorado State University
Fort Collins, CO 80523*

Final report

Approved for public release; distribution is unlimited.

Abstract

High-strength bolts are used extensively in structures and are regarded as a reliable option for connections subjected to cyclic fatigue loads in comparison to welded and riveted connections. Previous studies have highlighted that the fatigue of bolts in tension is not a concern if the bolts are properly pre-tensioned. However, these studies have not considered the potential loss of pre-tension. Nevertheless, a recent application of properly pre-tensioned bolts in miter gates that were subjected to multi-axial fatigue, producing tension and shear stress reversals, shows extensive fatigue cracking that was manifested through complete bolt failure. Sufficient observations and reports exist suggesting the possibility of fully pre-tensioned bolts coming loose due to shear stress reversals where the maximum transverse design load is below that of what would cause the connection to slip. The problem of transverse vibrational loosening of bolts and the issue of bolt fatigue has been extensively researched. Only recently have these subjects been considered together although no studies of this interaction have been conducted on high-strength bolts. Certain mechanisms mark the onset of bolt loosening and fatigue when bolts are subjected to cyclic shear or shear combined with tension. The actual mechanisms and limits at which this occurs are to be explored in this report. Future experimental and numerical studies will be conducted by the authors to verify these mechanisms for high-strength bolts and provide design and installation recommendations.

DISCLAIMER: The contents of this report are not to be used for advertising, publication, or promotional purposes. Citation of trade names does not constitute an official endorsement or approval of the use of such commercial products. All product names and trademarks cited are the property of their respective owners. The findings of this report are not to be construed as an official Department of the Army position unless so designated by other authorized documents.

DESTROY THIS REPORT WHEN NO LONGER NEEDED. DO NOT RETURN IT TO THE ORIGINATOR.

Contents

Abstract	ii
Figures and Tables.....	iv
Preface.....	v
1 Motivation and Introduction	1
2 Loss of Pre-tension in Bolts	3
2.1 Non-Rotational Loss of Pre-tension	4
2.1.1 Embedding loss.....	4
2.1.2 Creep in Gaskets.....	4
2.1.3 Surface Coating Creep.....	5
2.1.4 Stress relaxation	5
2.1.5 Yielding caused by loading.....	5
2.1.6 Differential thermal expansion.....	5
2.1.7 Loosening via wear of the clamped parts.....	6
2.2 Rotational Self-Loosening	6
2.2.1 Axial loading and vibration	7
2.2.2 Torsional loading.....	7
2.2.3 Transverse vibration	8
3 Fatigue of High-Strength Bolts.....	14
3.1 Fatigue of Bolts Loaded in Tension	14
3.2 Fatigue of Bolts Loaded in Shear	16
3.3 Combined Axial and Transverse Loading on Bolts.....	20
3.4 Multi-axial Fatigue	20
3.5 Environmentally Assisted Cracking.....	21
4 Conclusion, Hypothesis, and Future Research	23
4.1 Conclusions.....	23
4.2 Hypothesis	24
4.3 Future Research	24
References	26
Report Documentation Page	

Figures and Tables

Figures

Figure 1. Axial oscillation set-up (Goodier and Sweeney 1945).	7
Figure 2. Schematic of a typical transverse vibration loosening experiment: after Pai and Hess (2002).	9
Figure 3. Thread slip accumulation with points of stick, slip, and strain for each point during the shear reversal.	10
Figure 4. Two stages of loosening and nut rotation (Jiang et al. 2003).....	10
Figure 5. Typical plot of displacement amplitude vs. number of cycles (Jiang et al. 2004).	11
Figure 6. Bolt subjected to cyclic tension and crack nucleation at the first engaged thread: after Schijve (2001).	16
Figure 7. Loosening fatigue mechanism (Hashimura and Socie 2006).....	19
Figure 8. Categorization of multi-axial fatigue approaches according to You and Lee (1996).....	21

Tables

Table 1. Hole clearance for different thread fits (Nassar and Housari 2007).	12
Table 2. Fatigue tests on untightened bolts (Fisher et al. 1952).....	15
Table 3. Endurance of pre-tensioned bolts. Mean load of 5 tons with an alternating load = ± 2.5 tons (Fisher et al. 1952).	15

Preface

This study was conducted for the Information Technology Laboratory (ITL) and Coastal and Hydraulic Laboratory (CHL) under the Navigation Systems Research Program (NSRP), Pintle Socket Redesign Work Unit. The technical monitors were Dr. Guillermo A. Riveros, P.E., and Donald Wilson.

The work was performed by Dr. Hussam N. Mahmoud and Santiago Rodriguez-Lopez from Colorado State University at Fort Collins, Colorado, and Dr. Guillermo A. Riveros, P.E., Computational Analysis Branch of the Computation Science and Engineer Division, U.S. Army Engineer Research and Development Center–Information Technology Laboratory (ERDC-ITL). At the time of publication, Elias Arredondo was Chief, Computational Analysis Branch (CEERD-IE-C); Dr. Jerry Ballard was Chief, Computation Science and Engineer Division (CEERD-IE); and David Richards, CEERD-IV-T was the Technical Director for ERDC-ITL. The Deputy Director of ERDC-ITL was Patti Duett, and the Director was Dr. Reed L. Mosher.

At the time of publication, COL Bryan S. Green was the Commander of ERDC, and Dr. Jeffrey P. Holland was the Director.

1 Motivation and Introduction

The purpose of this report is to shed light on existing research into the causes of fatigue failure of bolts in bolted connections, especially those that are used in typical pintle socket connections in miter gates that are subjected to cyclic loads in multiple directions. As such, the intent is to provide a brief critical survey of the most relevant research on the fatigue failure of high-strength structural bolts. There is a particular focus on bolt loosening due to cyclic shear as a precursor to axial fatigue and fatigue under shear and tension. This review considers several potential precursors or coadjutants, including improper pre-tension, corrosion, and hydrogen embrittlement of steel.

The shift from an agrarian society into an industrialized era saw a great upsurge in the demand for threaded fasteners. Since the end of the 18th century with James Watts' invention of the steam engine, the desire to mechanize production brought an increase in the fabrication of bolts and nuts to clamp plates and parts together. At first, there was no standardized thread shape, and only the manufacturer of a given machine would produce the required fastener. Bolts were not interchangeable until the introduction of standardized threads in depth, pitch, and form for any given diameter by Joseph Whitworth in 1841. Later during World War I and World War II, further efforts to standardize the production of bolts were made based on various research studies.

The aerospace and automotive industries have conducted considerable research concerning the fatigue failure of bolts and their loosening due to transverse vibration. In structural and civil industries, however, high-strength bolts have not been studied as extensively under cyclic shear. Aside from classifying joints as slip critical and bearing type (AISC 2010), not much attention has been given to the loss of pre-tension due to shear cyclic loading as a precursor to fatigue.

For bolt fatigue to exist, there needs to be stress cycles (or fluctuation of stress) applied to the bolt either in tension or in shear, as would be expected when subjected to actual service loads under a combination of both tension and shear. This type of fatigue with multiple loading axes would be defined as "multi-axial fatigue." These stress variations must

remain below an experimentally determined Constant Amplitude Fatigue Limit (CAFL) to completely avoid fatigue.

It is important to note that when a bolt is properly pre-tensioned, fatigue life should not be of concern as long as the pre-tension load is not overcome by the applied tension load (Fisher et al. 1952). However, it has been shown that when sufficient shear force is applied throughout a series of cycles to a properly pre-tensioned bolt, loosening will take place (Junker 1969, 1973; Nassar and Housari 2007; Yokoyama et al. 2012). Other observations include that when the cyclic shear force is as low as 59% of the force that will cause complete slip of the head, loosening of the bolt will occur due to localized slip at the threads (Pai and Hess 2002; Dinger and Friedrich 2011). It is worth noting that previous studies have been conducted on non-structural bolts that demonstrate their potential for loosening under a shear force that is lower than 59% of the force that causes slip. It is therefore logical to hypothesize, that there exists a potential for the loosening of structural bolts, and such a hypothesis merits further evaluation.

When considering the above discussions, to better understand what contributes to the potential causes of bolt fatigue when used in pintle socket connections, one must look into the potential for loss of pre-tension of the bolt. In that regard, the following review of studies concerning the causes of loss of pre-tension clarifies the necessary and sufficient conditions required for continued loosening. That is to say, enough information exists to account for the necessary loss of pre-tension for fatigue-related issues to arise.

2 Loss of Pre-tension in Bolts

The problem of bolt loosening ranges from early stage loss of pre-tension due to plastic deformations, to nuts fully rotating loose from bolts. The most common occurrence of total self-loosening has always been in applications with high levels of vibration, such as train tracks and automobiles. The issue of nuts rotating loose is more than a century old as registered by early patent records. Ever since the late 1800s there have been various patents recommending improvements in fastener design to stop them from inadvertently loosening on the joints. For example, a proposed nut-locking method for preventing railroad fasteners from rotating loose was suggested by Edward Kaylor (1873), where a pliable metal washer with a layer of hard rubber underneath was used. The rubber forces the washer to bend around the corners of the nut under the pressure of the preload. This attempts to prevent the nut from rotating. The effectiveness of this solution is questionable since it reduces the stiffness of the connection, subjecting the bolt to carry the load excursions and making it more prone to fatigue. Nevertheless, this is one example of many similar patents that reveal the incidence of bolt loosening during the mid-eighteen hundreds.

Many experiments were conducted to isolate the causes of the loosening problem. Early tests by German engineers in the 1930s attributed loosening to plastic deformation within the fastener and on the joint surfaces (Boomsma 1955). The problem of sustained loss of pre-tension was studied experimentally via load oscillation in a variety of experiments without being able to entirely replicate the issue. The problem was not entirely isolated until transverse vibration was finally evaluated by Junker in 1966 (Junker and Strelow 1966). Although further work has been done since then, this test method still remains the benchmark in the aerospace and automotive industries for testing the potential for loosening of fasteners under vibration.

Subsequently, Hashimura and Socie (2006) studied fatigue and loosening as a coupled phenomenon under transverse load. These studies, however, were limited to the automotive industry and its unique bolt sizes and classes.

The following is a discussion of the causes for loss of pre-tension (alternatively called loosening) of bolts by which joints lose their clamping force. Subsequently, the studies on the fatigue behavior of bolts, in relation to loosening, are summarized and discussed. Finally, a brief discussion of the effects of combined longitudinal and transverse cyclic loading on the fatigue and loosening of bolts is included.

2.1 Non-Rotational Loss of Pre-tension

The causes of non-rotational loss of pre-tension are numerous, and researchers have explored each aspect to some extent in the past century. However, the contribution that non-rotational losses make to the total potential loss of pre-tension is relatively small, and not all causes need be considered for a given connection. These causes include embedding, creep, relaxation, yielding, thermal gradients, and wear are discussed in some detail below.

2.1.1 Embedding loss

Embedding loss is due to localized plastic deformation of the surfaces at molecular contact points beneath the head and the nut and in between joint surfaces. This loss amounts to usually only about 10% of the total preload. Researchers have found that once tightening has been established, approximately 80% of this type of loss occurs when it is first loaded under service loads and that the remaining 20% occurs over time (Meyer and Strelow 1972). The design of the joints usually accounts for embedding loss.

2.1.2 Creep in Gaskets

Gasket creep occurs when soft sealing materials between stiffer joint metals experience a reduction in their seating stress over time. Gaskets are mostly used in pressure pipes and automobiles to produce a tight seal where leaks are to be avoided. Recent developments have improved this issue with respect to previous design methods by enforcing leak tightness of the joint to prevent emissions. These improvements are achieved by taking into consideration parameters such as the creep factor of the gasket, the scattering due to the tightening of the device, the unloading compressive modulus of elasticity of the gasket, and the rate of change of said modulus of elasticity with compressive stress (Zerres and Guérout 2004).

2.1.3 Surface Coating Creep

To avoid corrosion, bolts and joint components are coated with a material lower on the galvanic scale than steel. Zinc is a common material used and is applied via electro-plating or hot-dip galvanizing, providing a coating thicknesses of 8 μm and 40 μm , respectively. This can become an issue when the bolt is holding together several plates with zinc layers generating an added total deformable zinc thickness that could be greater than the elongation of the bolt produced by the pre-load. Yang and DeWolf (1999) conducted a study that tested several coating materials. They determined that the loss of clamping force in galvanized-steel high-strength bolts is primarily due to creep strain in the galvanized coating. The creep strain can be represented as

$$\varepsilon(t) = \alpha + \beta tm \tag{2-1}$$

where ε is the creep strain; t is time; and α , β , and m are constants determined experimentally.

2.1.4 Stress relaxation

Very similar to creep, stress relaxation is a long term loss. This occurs when a high level of stress is applied, initially producing a strain that is maintained through time. This is a phenomenon governed by temperature and the level of stress/strain at which the material is maintained. Moreover, different materials have different behaviors in this respect. For instance, Tendo et al. (2001) found that in the case of type 304 N plates and cold-rolled type 304 plates, deformation could not be observed and the decrease in the bolt stress was no more than 2%.

2.1.5 Yielding caused by loading

Given that bolts are preloaded at stresses slightly below or at the yield stress of the material, additional loads large enough to overcome the clamping force and add to the preload of the bolt may cause it to yield or exceed the yield stress. The design considerations for the joint normally account for this.

2.1.6 Differential thermal expansion

Because the bolt shaft is contained inside the air gap of the bolt hole, which is then sealed by the clamping head and nut, it can cool or heat at a

slower rate than the surrounding joint materials. This produces a variation in the clamp force, which, according to Sears and King (2004), can produce fugitive emissions on flanged joints of pressure pipes where connections must stay within tight tolerances. However, this reduction in the preload is temporary and does not account for sustained loosening.

2.1.7 Loosening via wear of the clamped parts

In some cases, the design of the joint requires the accommodation of movements through a specific degree of friction. For example, in railroads, such is the case of fishplates that secure rail sections together and sustain movement from the rails expanding and contracting. In this case, a bolted joint can sustain fretting wear, which could produce a brown powder called “cocoa” (Sakai 2008). The presence of the powder is an indication of the loss of material, corresponding to a loss of pre-tension.

Micro-slip is another cause of this type of wear, which can occur in many locations on the joint, including regions away from the bolt when it is properly pre-tensioned and on the bolt itself. It is however, more likely to occur first in regions away from the hole because clamping force drops with distance from the bolt. In their study of uncertainties in bolted joints, Ibrahim and Pettit (2005) considered wear through micro-slip in regions away from the hole as a damping mechanism. This varied non-linearly with the amplitude of the tangential force. Pai and Hess (2003) studied micro-slip on the threads and found that it can accumulate and lead to complete slip and rotational self-loosening of a bolt.

2.2 Rotational Self-Loosening

Rotational self-loosening, also denoted simply as “loosening,” is the type of loss of pre-tension that has generated the most concern, as it can propitiate sudden and catastrophic failures. This is a widely recognized failure mechanism in the automotive and aeronautical industries. For example, Toyota recalled 26,830 Tacoma pickup trucks from 2005 to 2011 due to issues with a loosening fastener that presented a major risk of seat belt failure (Transport Canada 2013). In addition, in a report on the investigation of the 20 August 2011 crash of the Unmanned Aerial Vehicle, EQ-4B Global Hawk, *T/N 04-2017*, from the U.S. Air Force, insufficient cap screw torque was cited as a contributory factor to the mishap (Lozier 2012). The following is a summary of the historic progression in research toward a better understanding of the causes of rotational self-loosening.

2.2.1 Axial loading and vibration

The first theories about rotational loosening were based on the assumption that an oscillatory axial load on the bolt would have the effect of rotating the nut loose. The first researchers to propose a theory of axially loaded loosening were Goodier and Sweeney (1945). In their study, 19 mm (3/4 in.) bolts were loaded from 2.22 kN to 26.69 kN (500 lb to 6000 lb) in tension while monitoring the rotation of the nut. The maximum rotation detected was 2 degrees, and the minimum was 0.7 degrees in 500 cycles. Figure 1 illustrates the arrangement used to conduct axial loading tests.

Figure 1. Axial oscillation set-up (Goodier and Sweeney 1945).

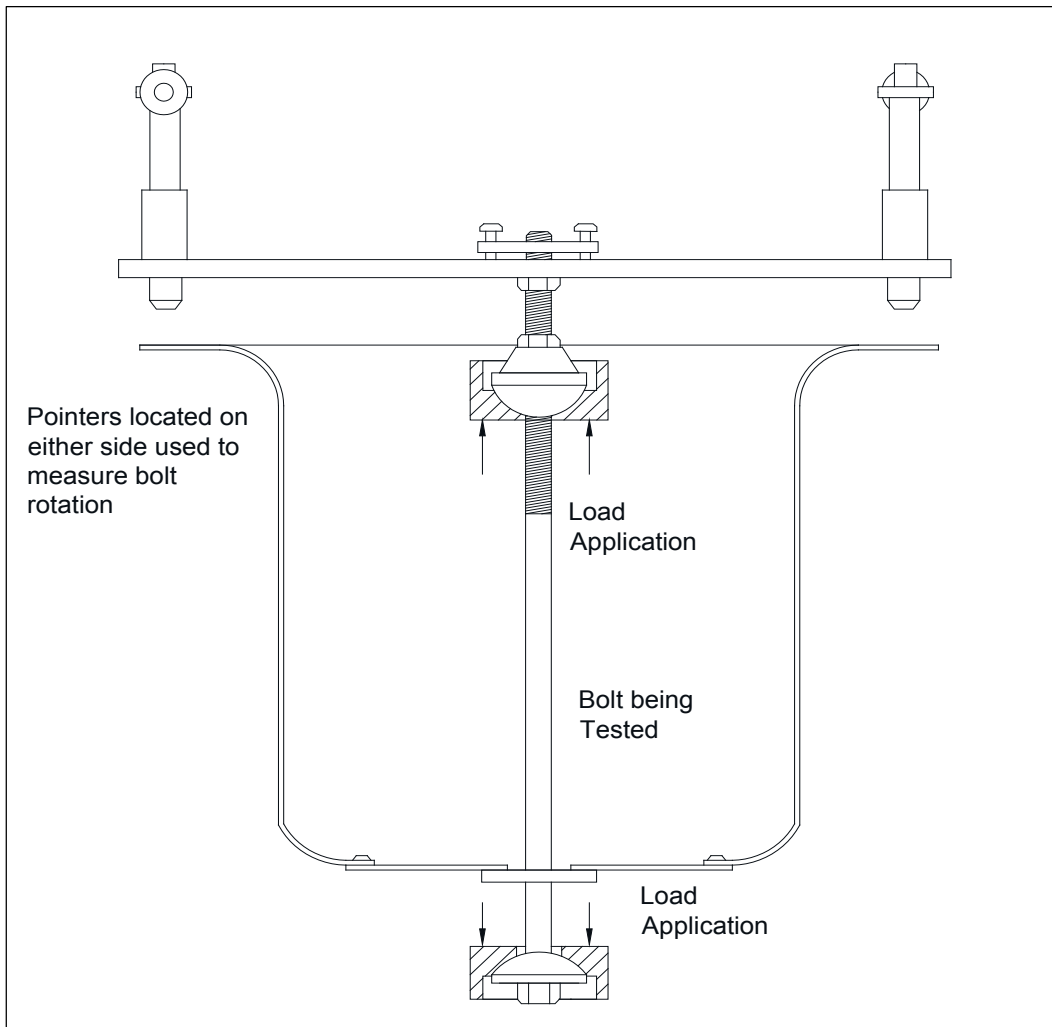

2.2.2 Torsional loading

The study conducted by Yokoyama et al. (2012) investigated the self-loosening of bolted joints under rotational loading and was concerned with

the relationship between the loosening torsion and tightening torsion when subjected to rotational loading. The bolts tested were M14 (0.55 in. diameter) with a grip length of 160 mm (6.3 in.) and were located between two rotating plates with sensors for bolt head rotation, bolt shaft torsion, and pre-tension. The results of the study confirmed that loosening does occur when the thread surface undergoes complete slip. It was determined that the argument $T_{SL} < T_W < T_{ST}$ needs to hold true for there to be sustained loosening.

where;

T_{SL} is the torque required to cause slip on the threads in the loosening direction, T_{ST} is the torque required to cause slip on the threads in the tightening direction, and T_W is the torque required to cause slip on the bearing surface.

2.2.3 Transverse vibration

Pioneered by Gerhard Junker (1969), bolt loosening has been experimentally investigated in a variety of setups. Junker's innovative device was designed for testing loosening of fasteners caused by transverse vibration. Junker carried out tests on hex head cap screws DIN 933, M10x1.5x30, and socket head cap screws, 1960 series, 3/8 in.-16 × 1-1/4 in., subjecting them to a displacement controlled vibration. It was found that pre-tension was lost within 200 to 500 cycles and is due to both rotation of the nut and relaxation of the material the bolt is in contact with. This result was obtained in several tests run at frequencies of 10 cpm (cycles per minute) and 3000 cpm. For both frequencies, a similar behavior was observed as a function of the number of cycles (Junker 1969), hence, showing that the phenomenon of loosening is independent of frequency. Notably, the plots of Transverse Force vs. Number of Cycles resemble fatigue S–N curves, which later led Hashimura and Socie (2006) to study fatigue and loosening together. In addition, it was concluded that when sufficient force was applied to overcome static friction and cause the head of the bolt to slip, there will be rotational self-loosening of the fastener. This term was coined as *critical slip*. However, the concept of *critical slip* has been revised by the concept of localized slip at the threads by Pai and Hess (2002). Figure 2 shows the basic test setup for a loosening experiment.

Figure 2. Schematic of a typical transverse vibration loosening experiment: after Pai and Hess (2002).

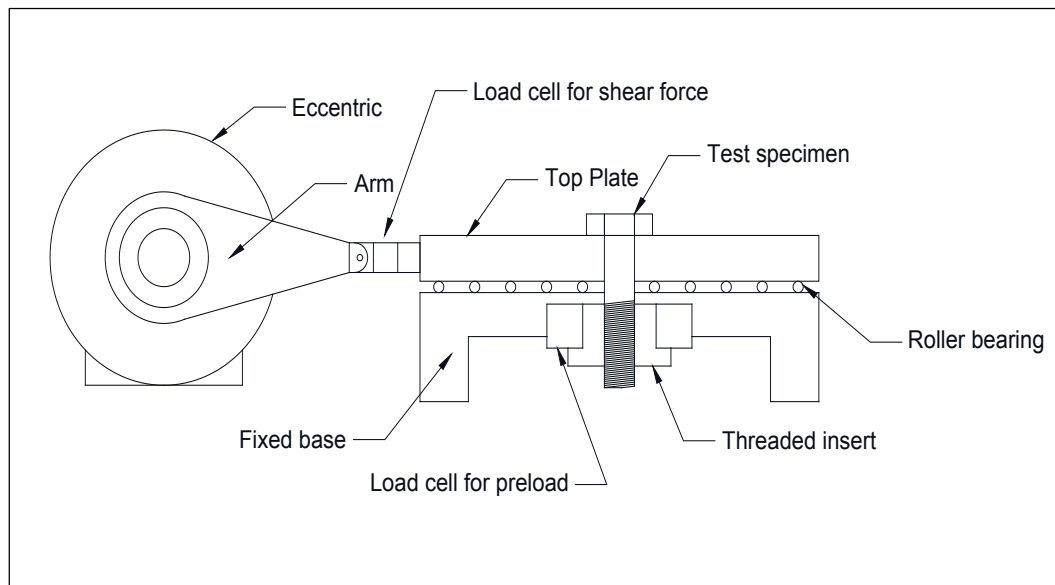

Pai and Hess (2002) conducted an “experimental study of loosening of threaded fasteners due to dynamic shear loads.” Their study tested 63.5 mm (2.5 in.) and 76.2 mm (3 in.) long grade 5 and grade 8, 0.5 UNC 13 (0.5 in. diameter and 13 threads per in.) screws with varying types of lubrication to induce different friction coefficients for the threads and the head. The results showed that loosening occurs at significantly lower shear forces than those required to initiate slip of the head. This occurs via localized slip in the threads, which is stored through friction on the back cycle and expands throughout the rest of the threads. In fact, the data showed that shear loads of 59%–66% of those required to cause complete slip of the head were sufficient to generate sustained loosening. The study highlighted the different factors contributing to loosening, and the source of loosening was eventually isolated through alternating types of lubricant on threads and head. Figure 3 shows the mechanism for the progressive loosening of a bolt via the accumulation of slip in the threads with varying direction of the shear force (F_s) throughout each cycle.

Jiang et al. (2003) investigated the early stage self-loosening of bolts under shear load. The results showed that early stage self-loosening is caused by local cyclic plastic deformation in the threads. Figure 4 shows the difference between early stage loosening and the faster rate of loosening in the second stage. In addition, comparing the displacement versus load-control tests revealed that displacement between the plates is a more influential factor in loosening compared to the shear force.

Figure 3. Thread slip accumulation with points of stick, slip, and strain for each point during the shear reversal.

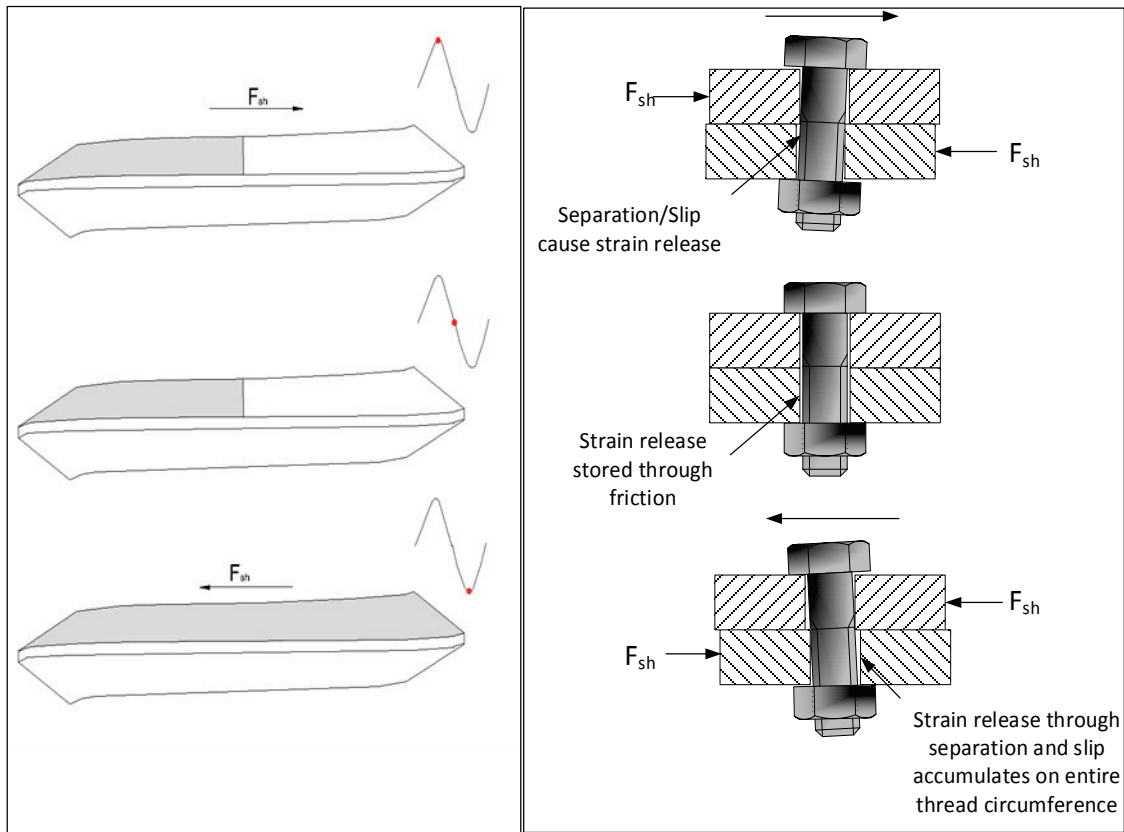
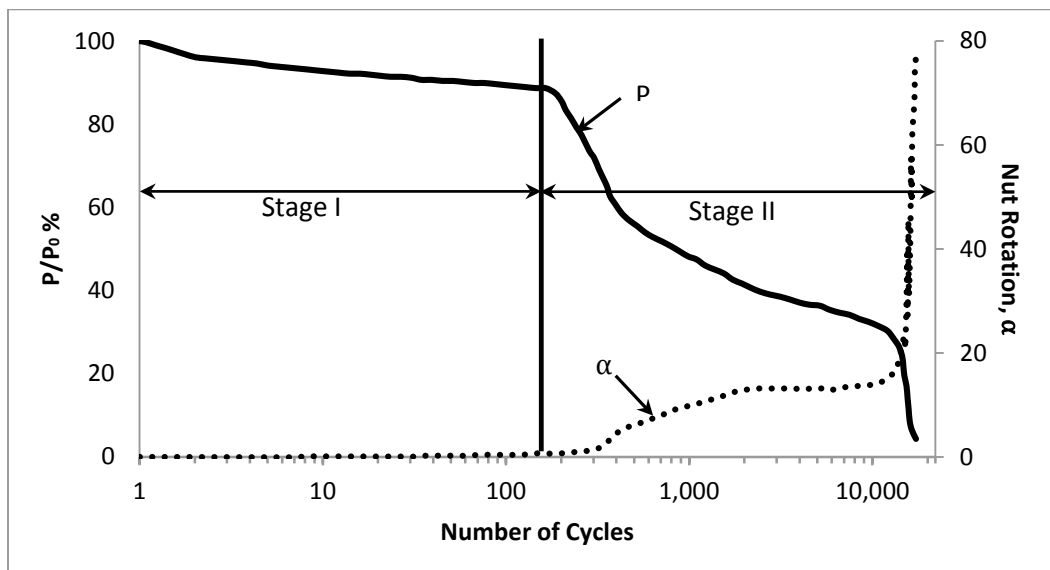

Figure 4. Two stages of loosening and nut rotation (Jiang et al. 2003).



After their initial investigations, Jiang et al. (2004) conducted another study using M12X1.75 (~0.5 in.) bolts preloaded up to 75% of the yield stress subjected to transverse cyclic displacement and found that the

dividing line between early stage loosening and continued self-loosening was at 0.5 degrees of nut rotation. In the early stage, the loss of preload occurs because of non-rotational causes such as stress relaxation. This loss then initiates the second stage of self-loosening in which the rotation of the nut dominates the loss of preload. Additionally, the plots of the amplitude of the displacement vs. the number of cycles to failure resemble fatigue S–N plots. Figure 5 shows a typical plot of the displacement amplitude against the number of cycles to loosening. For this study, total loosening was considered to have happened when the preload reached 10% of its initial value.

Figure 5. Typical plot of displacement amplitude vs. number of cycles (Jiang et al. 2004).

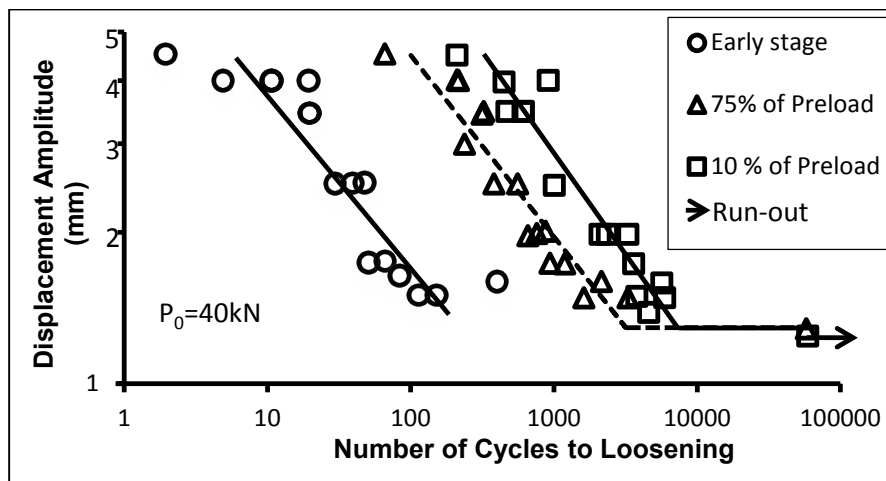

These plots are comparable to the ones developed by Junker (1969) where the transverse force applied to the bolt plotted against the number of cycles to complete rotational loosening resembles a fatigue S–N curve. Following this lead, Hashimura and Socie (2006) studied the loss of preload as a coupled phenomenon, namely loosening-fatigue under transverse load. This issue is discussed further in section 3.2.

Nassar and Housari (2007) examined the effects of hole clearance and thread fit on self-loosening of threaded fasteners and conducted tests on bolts with thread clearances of 3%, 6%, and 10% of the bolt’s nominal diameter. The bolts used in the study were hex head 1/2 in. 13 grade 5 with a thread fit of 2A and nuts fit that varied between 1B, 2B, and 3B. The machine used was a modified version of the Junker machine that added a bolt rotation sensor. It was concluded that when thread clearance is increased, loosening increases in a near-exponential fashion, assuming

that the displacement amplitude is sufficient to cause slip of the head and fully consume the available hole clearance. Table 1 shows the percentage of hole clearance for different thread fits that this study evaluated.

Table 1. Hole clearance for different thread fits (Nassar and Housari 2007).

Hole Clearance (% of diameter)	Thread Fit		
	1B-2A ¹	2B-2A	3B-2A
3%	3%/1B-2A	3%/2B-2A	3%/3B-2A
6%	6%/1B-2A	6%/2B-2A	6%/3B-2A
10%	10%/1B-2A	10%/2B-2A	10%/3B-2A

Dinger and Friedrich (2011) contributed to the research conducted in this field with both a numerical and an experimental study. They obtained their data experimentally using a more sophisticated version of the now standardized Junker setup, which allowed for measuring bolt head displacement. The bolts tested were M10 (~3/8 in.) 60–10.9 (following ISO 965 and DIN 13 specifications for the threads). The experimental study allowed for the confirmation that self-loosening is initiated when complete thread slip is achieved and localized slip at the head takes place though this type has a fairly lower rate of loosening than that occurring due to complete slip of the head.

Jiang et al. (2013) conducted an experimental study of bolts in curvic couplings with rotational transverse loading. This study included testing of 51 mm (2 in.) long bolts with a diameter of 5.71 mm (3/32 in.) and bolt head diameter of 8.88 mm (3/8 in.). The results confirmed that loosening due to cyclic transverse loading may be initiated through localized slip without complete slip at the bolt head and that self-rotation of the nut occurs without complete slip of the bolt head.

Friede and Lange (2009) studied the loosening phenomenon on M20 10.9 bolts (0.79 in.) with a preload of 160kN (36 kip) achieved according to the DIN 18800-7 standard with a torque wrench. This is roughly equivalent to an A-354 grade BD bolt with a 36 kip preload. A displacement of ±2 mm (0.08 in.) was applied to all specimens at frequencies of 0.2 to 1 Hz. Using equation (2-2) for the marginal slip (α) and varying the clamping length l_k from 20 mm to 100 mm (0.79 in. to 3.94 in.), they found that all bolts

¹ Combination of 1B nut thread fit and 2A bolt thread fit.

would loosen. Nevertheless, the loosening would occur at different rates depending on the clamping length.

$$a = \frac{F_v \mu l_k^3}{12EI} \quad (2-2)$$

where F_v is the preload, μ is the friction coefficient, l_k is the clamping length, E is Young's modulus, and I is the moment of inertia of the bolt section.

Although the 20 mm (0.79 in.) bolts, studied by Friede and Lange (2009), are the largest tested under the loosening scenario, all research on loosening of bolted connections was done predominantly within the automotive and aeronautic industries. Hence, the main focus of these loosening studies of fasteners is for automotive and aeronautical purposes under conditions of transverse vibration. However, it is important to note that so far no studies of self-loosening under transverse cyclic load have been performed on the sizes and classes of stainless steel, bronze, A325, or A490 high-strength structural bolts that are used in the construction of mitre gates for the pintle socket connections.

3 Fatigue of High-Strength Bolts

As previously indicated in Section 1, bolts could experience fatigue failure when subjected to axial tension cyclic loading if not properly preloaded, depending on the level of stress range applied. Substantial research has been conducted on the properties of bolts subjected to cyclic load along the longitudinal axis. Fisher and Beedle (1966), examined the existing literature on the topic of bolted and riveted joints up to that year and summarized several studies comparing bolts and rivets and highlighted the higher fatigue strength of bolts in comparison to that of rivets. This is owing to the fact that bolts are preloaded whereas rivets are not. These studies were accompanied by recommendations on tightening procedures for bolts to ensure proper preload and to resist slip.

High-strength bolts are the best means for connecting two members subjected to fatigue. Fisher and Beedle (1966) collected early studies that were conducted on the fatigue of bolts and rivets, with the earliest study dating back to 1938. The review of the literature shows the superior properties of high-strength bolts under fatigue. Munse (1970) also reported on extensive research conducted on rivets and high-strength bolts, and the fatigue characteristics of high-strength bolts was found to be superior to those of rivets and butt welds. It was also concluded that the specifications of the time for fasteners subjected to stress reversals that would cause fatigue was overly conservative. Munse (1970) suggested a reduction of 25% in the number of fasteners necessary for these types of connections from what was deemed necessary by the specifications. Munse (1970) noted that if holes are excessively oversized, an intolerable loss of clamping and reduction in fatigue resistance will result. Munse (1970) further concluded that the greatest fatigue resistance is always obtained with the highest clamping force. Each one of these early studies emphasized the importance of having the highest clamping force possible to increase the resistance to fatigue. Nevertheless, no cyclic shear tests were conducted.

3.1 Fatigue of Bolts Loaded in Tension

As mentioned above, fatigue may be avoided in bolts under tension cyclic loading if the bolts are properly preloaded. Specifically, bolts will not fail due to fatigue as long as the service loads remain below those for which the joint was designed. Fisher et al. (1952) studied the effects of preloading

on the fatigue life of bolts under tension. The study indicated that fatigue can be avoided with a proper level of pre-tension. In such cases, the preload will be sufficient to maintain pressure between the clamped plates under the maximum tension on the bolt. This relieves the bolt of the load fluctuation and hence, fatigue is not an issue. Tables 2 and 3 summarize the results of the experiment conducted by Fisher et al. (1952).

Table 2. Fatigue tests on untightened bolts (Fisher et al. 1952).

Mean load 5 tons	
Alternating Load (Tons)	Endurance (Cycles)
2.5	143,000
2.5	84,500
2.5	199,000
2.5	143,000
2	295,000
1.65	554,000
1.5	1,020,000
1.45	15 million unbroken
1.28	15 million unbroken

Table 3. Endurance of pre-tensioned bolts. Mean load of 5 tons with an alternating load = ± 2.5 tons (Fisher et al. 1952).

Bolt No.	Pre-Tension		Endurance (Cycles)
	Load (Tons)	Stress (Tons/in ²)	
1	0	0	143,000
2	1.38	3.9	73,000
3	2.41	6.85	89,800
4	3.88	11	333,000
5	5.8	16.4	519,000
6	6.54	18.5	10 million unbroken
7	7.9	22.4	11.6 million unbroken
8	9.57	27	13.2 million unbroken

Experiments have been conducted on bolts loaded in cyclic tension, including prying action (Astaneh et al. 1989). Astaneh et al. (1989) evaluated double-angle, beam-column connections and subjected them to rotation. They were fastened using $\frac{3}{4}$ in. ribbed bolts that had been removed from an existing structure along with new $\frac{3}{4}$ in. diameter A 325 bolts. The resulting load configuration on the bolts was cyclic tension with

some prying action. They determined that these idealized pinned ended connections would fail because of bolt failure due to thread stripping at a rotation greater than 0.025 radians (1.43 degrees) on the ribbed bolts, which contained shallow threads. Conversely, A 325 bolts that had been properly pre-tensioned to 70% of proof strength developed ductile behavior, and the failure occurred in the angles. Figure 6 shows a preloaded bolt subjected to cyclic tension and a crack nucleating at the first engaged thread.

Figure 6. Bolt subjected to cyclic tension and crack nucleation at the first engaged thread: after Schijve (2001).

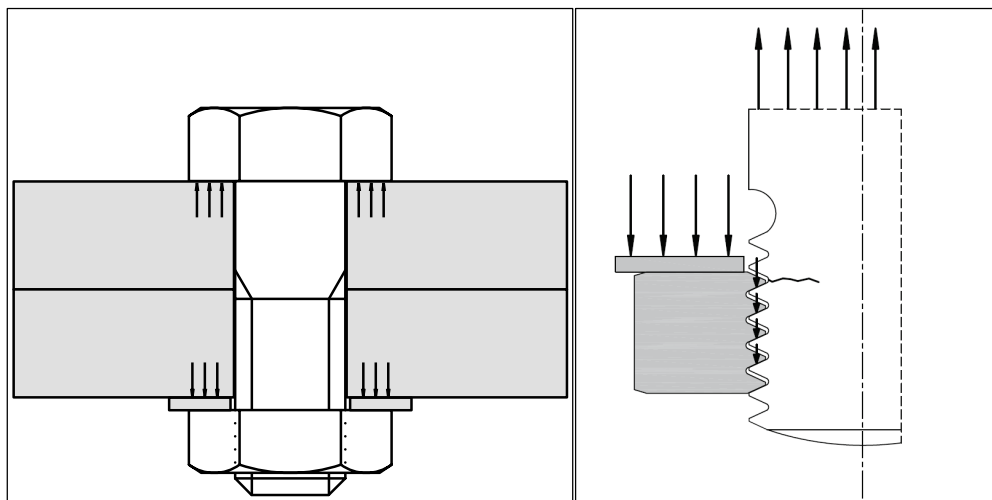

3.2 Fatigue of Bolts Loaded in Shear

Bolted connections loaded in shear may be pre-tensioned or not pre-tensioned. When a bolt is pre-tensioned, the shear is transferred through friction as long as there is no slip between the surfaces. The American Institute of Steel Construction (AISC, 2010) provides specifications for the design of slip-critical connections in the *Specification for Structural Steel Buildings*. That includes applications where it is necessary to avoid any slip between the surfaces. The Specification for structural joints using high-strength bolts (RCSC, 2009) states that slip-critical joints are required in applications involving shear or combined shear and tension where the joints are subject to fatigue load with reversal of the loading direction. To avoid slip, the connection should be designed using the following slip resistance given in the *Specification for Structural Steel Buildings* (AISC, 2010) under section J3.8., in equation (J3-4), and shown below.

$$R_n = \mu D_u h_f T_b n_s \tag{3-1}$$

Where R_n is the available slip resistance, μ is the mean slip coefficient for Class A or B surfaces as applicable and as follows or as determined by tests:

- For Class A surfaces (unpainted clean mill scale steel surfaces or surfaces with Class A coatings on blast-cleaned steel or hot-dipped galvanized and roughened surfaces), $\mu=0.30$.
- For Class B Surfaces (unpainted blast-cleaned steel surfaces or surfaces with Class B coatings on blast-cleaned steel), $\mu=0.50$.

D_u is 1.13, a multiplier that reflects the ratio of mean installed bolt pre-tension to specified minimum bolt pre-tension. Other values may be stipulated by the engineer of record. T_b is the minimum fastener tension given in Table J3.1 kips or Table J3.1M kN, n_s is the number of slip planes required to permit the connection to slip, and h_f is the factor for fillers determined as follows:

- Where there are no fillers or where bolts have been added to distribute loads in the filler, $h_f = 1.0$.
- Where bolts have not been added to distribute the load in the filler, for one filler between connected parts, $h_f = 1.0$, and for two or more fillers between connected parts, $h_f = 0.85$.

In the case of slip critical connections, stress is not concentrated on the contact interface between the bolt and the hole but is transmitted through friction between the clamped parts. An essential factor is the friction coefficient between the plates, which determines the friction force that transfers the stresses throughout the jointed components. When the static friction is overcome, several mechanisms begin to take place that contribute to the load transfer mechanism and to the degradation of the joint surfaces. Ibrahim and Pettit (2005) noted that when slip occurs, friction coefficients change with each loading phase because of wear and this gradual degradation of the surfaces produces uncertainties.

Following the lead of the similarity of the loosening curves to the S-N fatigue curves developed for bolted and welded connection, Hashimura and Socie (2006) studied the coupled phenomenon of loosening and fatigue of bolted joints subjected to transverse vibration. The study included testing M10 bolts without washers and with threads in the shear plane. The experiment was run under displacement control with the use of rollers in between the plates to reduce friction. Preloads were applied only

up to a maximum of 50% of the yield strength of the bolts. The study showed that if a bolt loosens in the low cycle region of 10^3 to 10^4 cycles, crack nucleation is not present and that the loss of pre-tension is attributable to rotational loosening. Alternatively, if the bolt loosened in the high-cycle region of 10^5 to 10^6 cycles, a crack was observed at the root of the first engaged thread in every bolt tested (Hashimura and Socie 2006). Figure 7 illustrates the different mechanisms by which a bolt may loosen or fatigue as presented by Hashimura and Socie (2006).

Figure 7. Loosening fatigue mechanism (Hashimura and Socie 2006).

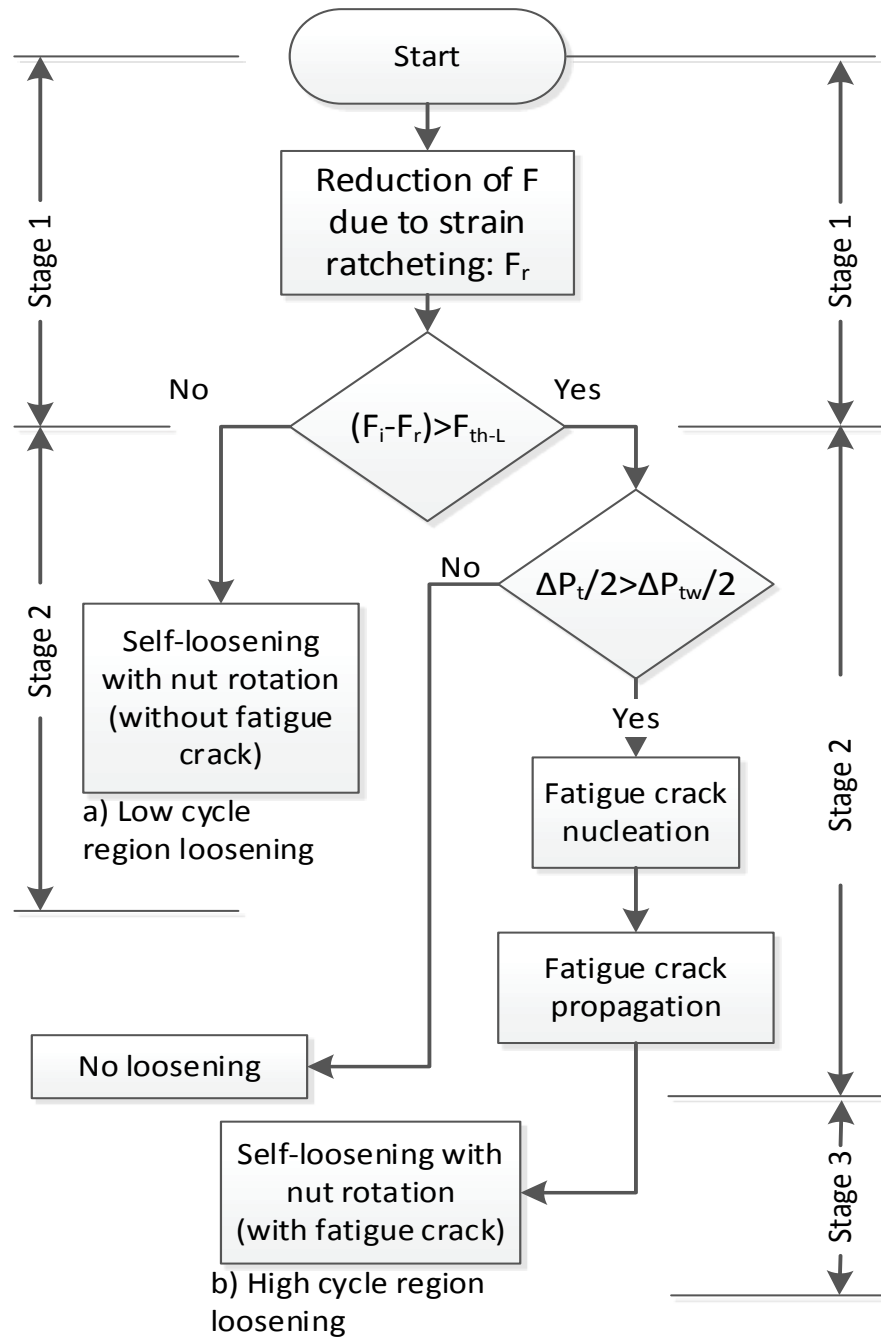

where

- F_r = reduction of preload caused by strain ratcheting,
- F_i = the initial preload,
- F_{th-L} = the threshold preload below which rotational loosening occurs,
- $\Delta P_t/2$ = the amplitude of the cyclic transverse force, and
- $\Delta P_{tw}/2$ = the threshold amplitude of transverse force above which fatigue takes place.

3.3 Combined Axial and Transverse Loading on Bolts

The AISC (2010) specifies that for a combination of loading in the axial and transverse direction, equation (3-2) can be used to determine a reduction factor to multiply by the available bolt slip resistance. R_n is obtained by equation (3-2).

$$k_{sc} = 1 - \frac{T_u}{D_u T_b n_b} \quad (3-2)$$

where:

K_{sc} is the reduction factor to be multiplied by R_n ; T_u is the required tension force using LRFD load combinations in kips or kN ; n_b is the number of bolts carrying the applied tension, D_u is as defined previously, 1.13, a multiplier that reflects the ratio of mean installed bolt pre-tension to the specified minimum bolt pre-tension; and T_b is the minimum fastener tension given in the AISC Specifications (AISC 2010) Table J3.1 kips or Table J3.1M kN

The K_{sc} factor varies from zero to one and is exactly zero when the tension per bolt is equal to the preload. Therefore, it simply states that when the applied tension is enough to nullify the contact force, the slip resistance is completely eliminated.

3.4 Multi-axial Fatigue

You and Lee (1996) reviewed and classified research conducted since 1980 on multi-axial fatigue. Most multi-axial assessments reduce multi-axial loading to an equivalent uniaxial loading. Approaches to multi-axial fatigue were classified by You and Lee (1996) into five different categories as shown in Figure 8. The results of this review study indicated that the major improvements in multi-axial fatigue assessment methods during this period were the consideration of material anisotropy and the application of Mohr's circle within energy methods. Several models were investigated and their applications and limitations discussed.

Figure 8. Categorization of multi-axial fatigue approaches according to You and Lee (1996).

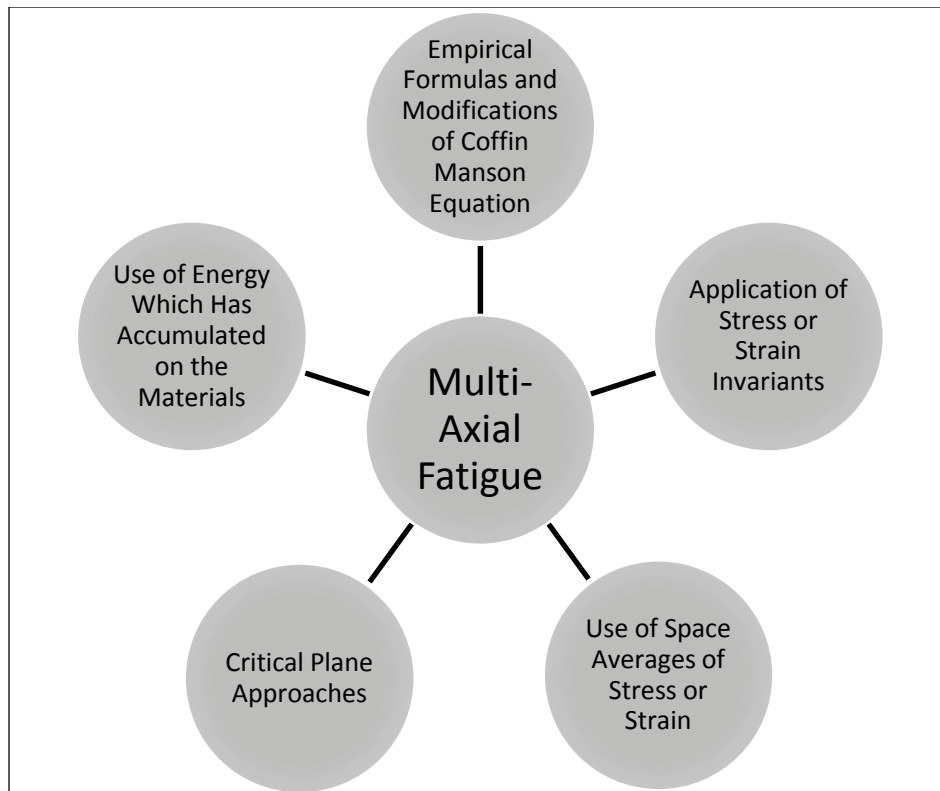

There are several types of loading in multi-axial fatigue. There can be either proportional or non-proportional loading depending on whether the principal stress orientation stays the same with respect to the loading axes throughout the loading cycles or if it rotates relative to the applied loads, respectively. In addition, the applied loading may be in phase or out of phase depending on whether the main loads are applied simultaneously or asynchronously with a shift in phase. The effects of these types of loading must be considered to appropriately describe the fatigue behavior of the material being analyzed given the predicted service loads (Socie and Marquis 2000).

3.5 Environmentally Assisted Cracking

Esaklul and Ahmed (2009) compiled and summarized studies and tests on environmentally assisted cracking (EAC). EAC comprises stress corrosion cracking (SCC), Hydrogen embrittlement, (HE) and sustained load cracking (SLC). High-strength steels along with titanium alloys and aluminum alloys are most vulnerable to EAC. However, their research shows that fasteners

with a Rockwell Hardness bellow HRC34¹ are not susceptible to environmentally assisted cracking.

Subsequently, Brahim (2014) summarized the latest knowledge on HE of fasteners, shedding more light on the issue of HE as defined by theoretical advances and experimental research. SCC and SLC are now considered subsets of HE, which is defined as “a permanent loss of ductility in a metal or alloy caused by hydrogen in combination with stress, either externally applied or internal residual stress” (Brahimi 2014). HE is a mechanism of failure that occurs when, within a tensile stressed metal, interstitial or diffusible hydrogen (hydrogen that is free to move) migrates to the point of highest stress concentration, making the steel brittle at that location. A crack eventually forms, and the hydrogen then migrates following the crack tip as the crack progresses until the point at which the element fractures.

With regard to the conditions of the fastener that precipitates the process, Brahim (2014) states that there are three main components: material susceptibility, the presence of hydrogen, and stress concentrations. The latter two are triggers whose intensity may speed up or slow down the process. The root of the phenomenon and the most influential cause in the process is material susceptibility due to poor material conditions arising from the manufacturing process. Studies show that within the properties that make a material susceptible to HE, the most important is hardness. The latest research consensus and standards arrive at the value of HRC 39 (± 1.0), below which most materials with well controlled manufacturing processes will not be susceptible to HE. This is contrasted with the recommendation by some standards that define more conservative values ranging from 31 to 35 HRC. These have been adopted primarily as a precaution against manufacturing errors. However, in well controlled production processes, a value of 39 (± 1.0) HRC has been established as the reference point for susceptibility.

The above condition for avoiding EAC is met by both A325 and A490 bolts according to their production properties. Although EAC could factor into the process of failure, it is considered minor since existing structures for lock gates have been designed according to specifications that call for corrosion-resisting materials (U.S. Army Corps of Engineers 1994).

¹ HRC represents the material hardness measured on the Rockwell C scale as is the case for most structural steel

4 Conclusion, Hypothesis, and Future Research

4.1 Conclusions

Fatigue studies on bolts under tension and shear have been reviewed with the conclusion that the problem of fatigue may be avoided with proper pre-tension of bolts. Therefore, the cause of fatigue must be linked to improper preload or loss of preload throughout the life of the bolt. Consequently, the following issues have been explored in this report:

First, many studies and theories addressing the problem of loss of pretension have been examined. It was found that the most accurate theories validated experimentally for the loss of pre-tension are the ones that isolate cyclic shear (both transverse as well as rotational) as the cause of the issue (Junker 1969, 1973; Nassar and Housari 2007; Yokoyama et al. 2012). Nevertheless, most of the research conducted has been done in the context of the automotive and aeronautical industries and no loosening studies have been conducted on proper structural bolts. However, the phenomenon of rotational self-loosening due to transverse vibration has been reduced to a critical cyclic displacement which occurs due to loading parameters as well as geometric factors and friction coefficients. Moreover, it has also been determined that the self-loosening phenomenon is independent from the frequency of the cyclic motion. Because of these two observations, this phenomenon may be extrapolated to larger structural bolts used in civil infrastructures such as mitre gates subjected to cyclic shear loads with lower frequencies than those found in the automotive and aeronautical vibration loads.

The second phenomenon explored is the issue of fatigue once sufficient preload has been lost, as well as throughout the loosening process. It was found that the coupled phenomenon of rotational self-loosening and fatigue (Hashimura and Socie 2006) evidences a balance between the two depending on several factors. Most important are the preload and the transverse force relative to the friction force. Consideration was also given to the increased rate of failure when considering the addition of tensile forces on the bolt. This has been provided for in the latest version of the AISC (2010) specification with a mathematical formula which considers

the reduction in slip resistance due to a reduction in the contact force. However, other factors will need to be considered once the bolt begins to loosen and this expression should be verified experimentally.

Thirdly, considering the lack of studies specifically on multiaxial fatigue of bolts, the available literature on the general topic of multiaxial fatigue as condensed by You and Lee (1996) and Socie and Marquis (2000) was summarized and their basic principles presented, serving as guidance for future studies concerning this more specific scenario.

Lastly, literature on the issue of environmentally assisted cracking (or hydrogen embrittlement) was explored to provide a framework for considering whether this is an issue for the bolts under consideration as well as reference material when considering other portions of the mitre gates. It was found that this phenomenon is not of major concern when it comes to the bolts given that they are usually below the hardness limits that would cause HE.

4.2 Hypothesis

The failure phenomenon is most likely comprised of two processes: one is the rotational loss of pre-tension, and the other is multi-axial fatigue.

If there is no slip, there should be no loosening, and therefore, fatigue would be present only at points on the plates where the stress is transmitted through contact between the clamped surfaces.

If there is slip, there are two possible scenarios:

- When loading is enough to generate localized slip at threads but not full slip of the head (force ~50% of force for slip of the head), there will be localized slip and a very low rate of loosening accompanied by fatigue cracks initiating at the root of the first engaged threads.
- When the mean force is sufficient to generate full slip of the head, there will be quick, sustained loosening in the range of 10^2 to 10^4 loading cycles.

4.3 Future Research

Although extensive studies have been conducted on the topics of fatigue and loosening, future experimental investigations seek to understand how

these phenomena may affect such large structural bolts as those used in canal lock gates. The development of these experimental data can provide an opportunity to improve the design specifications for these types of connection. From the results obtained experimentally, evaluation criterion of the existing structures may be surmised to accurately estimate their remaining life.

References

- AISC. 2010. *Specification for structural steel buildings*. Chicago, IL: American Institute of Steel Construction.
- Astaneh, A., M. N. Nader, and L. Malik. 1989. Cyclic behavior of double angle connections. *Journal of Structural Engineering* 115 (5):1101–1118.
- Boomsma, M. 1955. Loosening and fatigue strength of bolted joints. *The Engineer* 284–286.
- Brahimi, S. 2014. *Fundamentals of hydrogen embrittlement in steel fasteners*. Montreal, Quebec, Canada: IBECA Technologies Corp.
- Dinger, G., and C. Friedrich. 2011. Avoiding self-loosening failure of bolted joints with numerical assessment of local contact state. *Engineering Failure Analysis* 18(8):2188–2200. doi:10.1016/j.engfailanal.2011.07.012.
- Esaklul, K. A., and T. M. Ahmed. 2009. Prevention of failures of high strength fasteners in use in offshore and subsea applications. *Engineering Failure Analysis* 16(4):1195–1202. doi:10.1016/j.engfailanal.2008.07.012.
- Fisher, J. W., and L. S. Beedle. 1966. *Bibliography on bolted and riveted structural joints*. ASCE Manual Number. 48.
- Fisher, W. A. P., R. H. Cross, and G. M. Norris. 1952. Pre-tensioning for preventing fatigue failure in bolts. *Aircraft Engineering* 24(280):160–063.
- Friede, R., and J. Lange. 2009. Self loosening of prestressed bolts. *Nordic Steel Construction Conference NSCC2009*. Malmö, Sweden.
- Goodier, J. N., and R. J. Sweeney. 1945. Loosening by vibration of threaded fastenings. *Mechanical Engineer* 67:798–802.
- Hashimura, S., and D. F. Socie. 2006. A study of loosening and fatigue of bolted joints under transverse vibration. *Society of Automotive Engineers Technical Paper Series* 2005-01-13.
- Ibrahim, R. A., and C. L. Pettit. 2005. Uncertainties and dynamic problems of bolted joints and other fasteners. *Journal of Sound and Vibration* 279:857–936.
- Jiang, X., Y. Zhu, J. Hong, X. Chen, and Y. Zhang. 2013. Investigation into the loosening mechanism of bolt in curvic coupling subjected to transverse loading. *Engineering Failure Analysis* 32:360–373. doi:10.1016/j.engfailanal.2013.04.005.
- Jiang, Y., M. Zhang, and C. H. Lee. 2003. A study of early stage self-loosening of bolted joints. *Journal of Mechanical Design*, 125(9): 518. doi.org/10.1115/1.1586936.

- Jiang, Y., M. Zhang, T. W. Park, and C. H. Lee. 2004. An experimental study of self-loosening of bolted joints. *Journal of Mechanical Design* 126 (9):925–931. doi.org/10.1115/1.1767814.
- Junker, G. H. 1969. New criteria for self loosening of fasteners under vibration. *SAE Technical Paper* (690055) 314–335. doi.org/10.4271
- Junker, G. H. 1973. Criteria for self loosening of fasteners under vibration. *Aircraft Engineering* 45 (1):12–14.
- Junker, G., and D. Strelow. 1966. Untersuchung über die Mechanik des selbsttätigen Lösens und die zweckmäßige Sicherung von Schraubenverbindungen. *Draht-Welt*, 52, 103–114, 175–182, 317–335.
- Kaylor, E. 1873. Improvement in nut-locks. United States Patent Office, United States.
- Lozier, M. C. 2012. *United States Air Force aircraft accident investigation board report: EQ-4B Global Hawk, T/N 04-2017*. Afghanistan: U.S. Air Force.
- Meyer, G., and D. Strelow. 1972. How to calculate preload loss due to permanent set in bolted joints. *Assembly Engineering*.
- Munse, W. H. 1970. *Riveted and bolted structural joints*. Structural Research Series No. 365. Urbana, IL: University of Illinois.
- Nassar, S. A., and B. A. Housari. 2007. Study of the effect of hole clearance and thread fit on the self-loosening of threaded fasteners. *Journal of Mechanical Design* 129(6):586–594. doi.org/10.1115/1.2717227.
- Pai, N. G., and D. P. Hess. 2002. Experimental study of loosening of threaded fasteners due to dynamic shear loads. *Journal of Sound and Vibration* 253:585–602. doi.org/10.1006/jsvi.2001.4006.
- Pai, N. G., and D. P. Hess. 2003. Influence of fastener placement on vibration-induced loosening. *Journal of Sound and Vibration* 268:617–626. doi.org/10.1016/S0022-460X(03)00369-9.
- RCSC (Research Council on Structural Connections). 2009. *Specification for structural joints using high-strength bolts*. Chicago, IL: Research Council on Structural Connections. <http://www.boltcouncil.org/files/2009RCSCSpecification.pdf>. (accessed 16 November 2015).
- Sakai, T. 2008. *Bolted joint engineering*. Berlin, Germany: Beuth Verlag GmbH.
- Schijve, J. 2001. *Fatigue of structures and materials*. Dordrecht, The Netherlands: Kluwer Academic Publishers.
- Sears, G., and D. King. 2004. Joint integrity management of critical flanges. *International Journal of Pressure Vessels and Piping* 81:513–519. doi.org/10.1016/j.ijpvp.2003.12.021.
- Socie, D. F., and G. B. Marquis. 2000. *Multiaxial fatigue*. Warrendale, PA: Society of Automotive Engineers, Inc.

- Tendo, M., K. Yamada, and Y. Shimura. 2001. Stress relaxation behavior at high-tension bolted connections of stainless-steel plates. *Journal of Engineering Materials and Technology* 123 (4):198–202. doi.org/10.1115/1.1338481.
- Transport Canada, T. 2013. Motor vehicle safety recalls database. *Transport Canada Recall# 2013273*. <http://wwwapps.tc.gc.ca/Saf-Sec-Sur/7/VRDB-BDRV/search-recherche/detail.aspx?lang=eng&mk=0&md=0&fy=0&ty=9999&ft=&ls=0&sy=0&rn=2013273&cf=SearchResult> (accessed 16 November 2015).
- U.S. Army Corps of Engineers. 1994. *Lock Gates and Operating Equipment*. EM 1110-2-2703. Washington, DC: U.S. Army Corps of Engineers.
- Yang, J., and J. T. DeWolf. 1999. Mathematical model for relaxation in high-strength bolted connections. *Journal of Structural Engineering* 125 (7):803–809.
- Yokoyama, T., M. Olsson, S. Izumi, and S. Sakai. 2012. Investigation into the self-loosening behavior of bolted joint subjected to rotational loading. *Engineering Failure Analysis* 23:35–43. doi.org/10.1016/j.engfailanal.2012.01.010.
- You, B. R., and S. B. Lee. 1996. A critical review on multiaxial fatigue assessments of metals. *International Journal of Fatigue* 18 (4): 235–244. doi.org/10.1016/0142-1123(96)00002-3.
- Zerres, H., and Y. Guérout. 2004. Present calculation methods dedicated to bolted flanged connections. *International Journal of Pressure Vessels and Piping* 81:211–216. doi.org/10.1016/j.ijpvp.2003.11.011.

REPORT DOCUMENTATION PAGE			<i>Form Approved</i> OMB No. 0704-0188	
Public reporting burden for this collection of information is estimated to average 1 hour per response, including the time for reviewing instructions, searching existing data sources, gathering and maintaining the data needed, and completing and reviewing this collection of information. Send comments regarding this burden estimate or any other aspect of this collection of information, including suggestions for reducing this burden to Department of Defense, Washington Headquarters Services, Directorate for Information Operations and Reports (0704-0188), 1215 Jefferson Davis Highway, Suite 1204, Arlington, VA 22202-4302. Respondents should be aware that notwithstanding any other provision of law, no person shall be subject to any penalty for failing to comply with a collection of information if it does not display a currently valid OMB control number. PLEASE DO NOT RETURN YOUR FORM TO THE ABOVE ADDRESS.				
1. REPORT DATE (DD-MM-YYYY) June 2016		2. REPORT TYPE Final report		3. DATES COVERED (From - To)
4. TITLE AND SUBTITLE Causes of Pretension Loss in High-Strength Bolts			5a. CONTRACT NUMBER	
			5b. GRANT NUMBER	
			5c. PROGRAM ELEMENT NUMBER	
6. AUTHOR(S) Hussam N. Mahmoud, Santiago Rodriguez Lopez, and Guillermo A. Riveros			5d. PROJECT NUMBER	
			5e. TASK NUMBER	
			5f. WORK UNIT NUMBER	
7. PERFORMING ORGANIZATION NAME(S) AND ADDRESS(ES) Information Technology Laboratory U.S. Army Engineer Research and Development Center 3909 Halls Ferry Road Vicksburg, MS 39180-6199			8. PERFORMING ORGANIZATION REPORT NUMBER ERDC/ITL TR-16-2	
9. SPONSORING / MONITORING AGENCY NAME(S) AND ADDRESS(ES) Headquarters, U.S. Army Corps of Engineers Washington, DC 20314-1000			10. SPONSOR/MONITOR'S ACRONYM(S)	
			11. SPONSOR/MONITOR'S REPORT NUMBER(S)	
12. DISTRIBUTION / AVAILABILITY STATEMENT Approved for public release; distribution unlimited.				
13. SUPPLEMENTARY NOTES				
14. ABSTRACT High-strength bolts are used extensively in structures and are regarded as a reliable option for connections subjected to cyclic fatigue loads in comparison to welded and riveted connections. Previous studies have highlighted that the fatigue of bolts in tension is not a concern if the bolts are properly pre-tensioned. However, these studies have not considered the potential loss of pre-tension. Nevertheless, a recent application of properly pre-tensioned bolts in miter gates that were subjected to multi-axial fatigue, producing tension and shear stress reversals, shows extensive fatigue cracking that was manifested through complete bolt failure. Sufficient observations and reports exist suggesting the possibility of fully pre-tensioned bolts coming loose due to shear stress reversals where the maximum transverse design load is below that of what would cause the connection to slip. The problem of transverse vibrational loosening of bolts and the issue of bolt fatigue has been extensively researched. Only recently have these subjects been considered together although no studies of this interaction have been conducted on high-strength bolts. Certain mechanisms mark the onset of bolt loosening and fatigue when bolts are subjected to cyclic shear or shear combined with tension. The actual mechanisms and limits at which this occurs are to be explored in this report. Future experimental and numerical studies will be conducted by the authors to verify these mechanisms for high-strength bolts and provide design and installation recommendations.				
15. SUBJECT TERMS High strength bolts Cyclic Shear of bolts		Bolt failure Multi-axial fatigue of bolts Pre-tensioned bolts		Transverse vibrational loosening of bolts Fatigue of bolts
16. SECURITY CLASSIFICATION OF:			17. LIMITATION OF ABSTRACT	18. NUMBER OF PAGES 34
a. REPORT UNCLASSIFIED	b. ABSTRACT UNCLASSIFIED	c. THIS PAGE UNCLASSIFIED		
			19b. TELEPHONE NUMBER (include area code)	