

MIL-HDBK-1024/2
15 April 1987
SUPERSEDING
NAVFAC DM-24.2
June 1980

MILITARY HANDBOOK

HELIUM PLANTS AND STORAGE



NO DELIVERABLE DATA REQUIRED BY THIS DOCUMENT

DISTRIBUTION STATEMENT A. APPROVED FOR PUBLIC RELEASE: DISTRIBUTION IS
UNLIMITED

AREA FACR

HIL-HDBK 1024/2

ABSTRACT

Basic design guidance for helium storage, repurification, and distribution facilities, Category Code 142, is presented for use by experienced architects handling techniques, receiving facilities, working pressures, pipe sizing and strengths, valving, repurification techniques, and interlocked automatic control systems.

MIL-HDBK 1024/2

FOREWORD

This military handbook has been developed from an evaluation of facilities in the shore establishment, from surveys of the availability of new materials and construction methods, and from selection of the best design practices of the Naval Facilities Engineering Command (NAVFACENGCOM), other Government agencies, and the private sector. It uses to the maximum extent feasible, national professional society, association, and institute standards. Deviations from this criteria, in the planning, engineering, design, and construction of Naval shore facilities, cannot be made without prior approval of NAVFACENGCOMHQ Code 04.

Design cannot remain static any more than can the functions it serves or the technologies it uses. Accordingly, recommendations for improvement are encouraged and should be furnished to Naval Facilities Engineering Command, Western Division, Code 406, P. O. Box 727, San Bruno, CA 94066, telephone (808)471-8368.

This handbook shall not be used as a reference document for procurement. Do not reference it in Military or Federal specifications or other procurement documents.

MIL-HDBK 1024/2

LAND OPERATIONAL FACILITIES CRITERIA MANUALS

<u>Document No.</u>	<u>Title</u>
DM-24.01	Buildings and Other Structures
MIL-HDBK 1024/2	Helium Plants and Storage
DM-24.03	Oxacetylene, Nitrogen, and Breathing Oxygen Facilities

HELIUM PLANTS AND STORAGE

CONTENTS

	<u>Page</u>
Section 1. DESIGN CRITERIA	
1. SCOPE.....	1
2. CANCELLATION.....	1
3. RELATED CRITERIA.....	1
4. INFORMATION REQUIRED FOR DESIGN.....	1
5. FACTS ON HELIUM.....	2
a. Production.....	2
b. Shipping Containers.....	2
c. Characteristics.....	3
Section 2. PLANT AND STORAGE DESIGNS	
1. RECEIVING FACILITIES.....	5
a. Rail Spur.....	5
b. Truck Trailer.....	5
c. Compressor Station.....	5
2. STORAGE FACILITIES.....	5
a. Storage Capacity.....	5
b. High Pressure Storage Cylinders.....	6
c. Impure Helium Collection and Storage.....	8
d. Shipping Containers.....	8
e. Portable Storage.....	14
3. REPURIFICATION PLANTS.....	14
a. Cryogenic Adsorption.....	14
b. Pressure Swing Adsorption (PSA).....	18
c. Separation by Air Expansion.....	22
d. Interlocked Automatic Control Systems.....	25
4. DISTRIBUTION AND INTERCONNECT SYSTEMS.....	25
a. Block Flow Diagram.....	26
b. Piping and Instrument Diagram.....	26
c. Piping Plan.....	26
d. Distribution and Interconnect Piping.....	26
e. Piping Design.....	26
f. Underground Pipelines.....	30
g. Piping Test.....	31
h. Pipe Sizing.....	31
i. Valves.....	38
j. Control Valve Sizing.....	39
k. Instrumentation and Control Element Specifications.....	42

	<u>Page</u>
5. TRANSFER SHOP.....	43
a. Cylinder Regulations.....	43
b. Cylinder Filling and Shipping.....	43
c. Cylinder Retesting.....	45
6. SAFETY.....	46
a. General Safety for Helium Handling.....	46
b. Occupational Safety and Health Administration.....	47

Section 3. RELATED FACILITIES

1. ARCHITECTURAL REQUIREMENTS.....	49
a. Receiving and Storage Facilities.....	49
b. Transfer Shop.....	49
c. Repurification Plant.....	49
2. STRUCTURAL REQUIREMENTS.....	49
a. Compressor Foundations.....	49
b. Piping Supports.....	49
c. Hoists and Cranes.....	49
3. MECHANICAL REQUIREMENTS.....	49
a. Plumbing.....	49
b. Ventilating and Heating.....	50
4. ELECTRICAL REQUIREMENTS.....	50

FIGURES

1 Compressed Gas Cylinder Markings.....	7
2 Block Flow Diagram: Impure Helium Collection and Storage System.....	9
3 Piping and Instrument Diagram: Impure Helium Collection and Storage System.....	10
4 Legend, Piping and Instrument Diagram Notes and Symbols.....	11
5 Block Flow Diagram: Cryogenic Adsorption Repurification Process.....	15
6 Piping and Instrument Diagram: Cryogenic Adsorption Repurification Process.....	16
7 Block Flow Diagram: Pressure Swing Adsorption Repurification Process.....	19
8 Piping and Instrument Diagram: Pressure Swing Adsorption Repurification Process.....	20
9 Block Flow Diagram: Separation by Air Expansion Repurification Process.....	23
10 Process Flow Diagram: Separation by Air Expansion Repurification Process.....	24
11 Friction Factors for Clean Steel Pipe.....	33
12 Equivalent Length Resistance of Valves and Fittings.....	34
13 Two-Phase Pressure Drop Factors.....	37

MIL-HDBK 1024/2

	<u>Page</u>
14 Typical Control Valve Station.....	40
15 Block Flow Diagram: Transfer Shop Cylinder Filling and Shipping.....	44
16 Block Flow Diagram: Transfer Shop Cylinder Retesting.....	45

TABLES

1 Allowable Working Pressures for ASTM A106, Seamless Carbon Steel Pipe.....	27
2 Allowable Working Pressures for ASTM A312, Type 304L Stainless Steel Pipe.....	28
3 Allowable Working Pressures for ASTM A312, Type 316 Stainless Steel Pipe.....	29
. Line Sizing Criteria.....	32
5 Control Valve Station: Block and Bypass Valve Sizing.....	40
REFERENCES.....	51

MIL-HDBK 1024/2

HELIUM PLANTS AND STORAGE

Section 1. DESIGN CRITERIA

1. SCOPE. Data and criteria in this manual shall govern the design of helium storage, repurification, and distribution facilities.
2. CANCELLATION. This military handbook, MIL-HDBK 1024/2, cancels and supersedes NAVFAC DM-24.2, Helium Plants and Storage, dated June 1980.
3. RELATED CRITERIA. Other criteria related to helium appear in the criteria documents listed below: (also see References)

<u>Subject</u>	<u>Source</u>
Architecture	NAVFAC DM-1 Series
Loads	NAVFAC DM-2.02
Plumbing Systems	NAVFAC DM-3.01
Heating, Ventilating, Air Conditioning, and Dehumidifying Systems	NAVFAC DM-3.03
Compressed Air and Vacuum Systems	NAVFAC DM-3.05
Noise and Vibration Control for Mechanical Equipment	NAVFAC DM-3.10
Electrical Utilization Systems	NAVFAC DM-4.04
Energy Monitoring and Control Systems	NAVFAC DM-4.09
Civil Engineering Trackage	NAVFAC DM-5.06
Engineering and Design Criteria Preparation	NAVFAC DM-6 Series
Fire Protection for Facilities Engineering, Design, and Construction	MIL-HDBK-1008
Color for Naval Shore Facilities	NAVFAC P-309
Seismic Design for Buildings	NAVFAC P-355

3. INFORMATION REQUIRED FOR DESIGN. Obtain the following data for the project:

- a. Schematic flow diagrams, including a general process block flow diagram (BFD), and a piping and instrument diagram (P&ID), showing required operating features.
- b. Plot plan of project showing location of buildings, railroads, roads, interferences, and terrain.
- c. Requirements for working time and standby time.
- d. Volumetric, pressure, and temperature requirements.
- e. Local building, planning, and environmental regulations.
- f. Local material and labor construction costs.
- g. Soil conditions and seismic zone regulations.
- h. Weather and climatic conditions.

MIL-HDBK 1024/2

4. **FACTS ON HELIUM.** Federal agencies use helium gas for a variety of applications, as do industrial, medical, scientific, and research organizations.

These applications include helium-shielded arc welding, wind tunnels, controlled atmospheres and breathing mixtures, atomic reactors, blanket gas for crystal growth, cryogenic research, and guided missile work. Helium is often used in the liquid state.

a. Production. The Department of the Interior, Bureau of Mines, currently produces roughly 315 million standard cubic feet (scf) of helium per year. (Standard cubic feet is the volume of the gas if it were contained at the standard conditions of 70° F and 14.696 pounds per square inch absolute (psia). The standard conditions currently in use by the U.S. compressed gas industry for metric systems are 0° C and an absolute pressure of 0.101 33 megapascals (MPa) for measuring a normal cubic meter.) Bureau of Mines sales amount to approximately 24 percent of the total U.S. helium market. Grade A helium is sold to federal agencies and the public per Title 30, Code of Federal Regulations (CFR) Parts 601 and 602, Mineral Resources. Federal agencies that use more than 5,000 scf per month are required to purchase their helium exclusively from the Bureau of Mines. It is anticipated that the Bureau of Mines will be able to supply helium to the federal market until at least the year 2024.

b. Shipping Containers. Department of Transportation (DOT) cylinder specifications are presented in 49 CFR 178, Transportation - Shipping Container Specifications. DOT replaced the Interstate Commerce Commission (ICC) as the regulatory body responsible for shipping container specifications in 1967. This cylinder and an ICC-3A cylinder conform to the same basic specification. Helium is shipped from the Bureau of Mines production plants as both a gas and a liquid in the following containers:

(1) Railroad Tank Cars. Railroad tank cars contain thirty 18-inch diameter, 33-foot long seamless steel cylinders that meet DOT specification 107A requirements. Total volume per tank car is roughly 1225 cubic feet. Railroad tank car cylinders are commonly shipped at 3,600 pounds per square inch gauge (psig), thus holding 300,000 scf of helium gas.

(2) Truck Trailers (tube trailers). Helium tube trailers contain ten 22-inch diameter, 32-foot long seamless steel cylinders that meet DOT specifications 3AX, 3AAX, or 3T. The total volume is about 750 cubic feet. Tube trailers are commonly shipped at 2,400 psig, thus holding 122,000 scf of helium gas.

(3) Portable Compressed Gas Cylinders (K-bottles). K-bottles are 9-inch diameter, approximately 51-inch long, portable seamless steel cylinders that meet DOT 3A or 3AA specifications; each cylinder has a volume of approximately 2,675 cubic inches, or 1.5 cubic feet. K-bottles are commonly pressurized to 2,265 psig, thus holding 240 scf of helium gas.

MIL-HDBK 1024/2

(4) **Liquid Helium Containers.** Liquid helium containers are vacuum insulated stainless steel Dewar flasks for land shipments of liquid helium via common carrier. Dewar flasks are available in 100-liter and 500-liter sizes; the 100-liter flask holds the equivalent of 2,660 scf of helium gas, while the 500-liter flask holds the equivalent of 13,300 scf of helium gas. Liquid helium containers are commonly shipped at pressures less than 40 psig, and thus shipments are not regulated by federal authority.

(5) **Liquid Helium Tanks.** Liquid helium tanks are 10,900-gallon Dewar flasks. The tank is vacuum insulated and thermally shielded with liquid nitrogen, allowing for 30-day shipments with only 5 percent vaporization. Each tank contains 10,900 U.S. gallons of liquid helium under pressures of 1 to 50 psig at -452° F. The liquid helium is equivalent to 1,098,000 scf of helium gas. The liquid helium tanks owned by the Bureau of Mines are housed in an 8-foot wide, 8-1/2-foot high, 40-foot long frame suitable for shipment by road, rail, or water. Shipments are authorized by DOT Special Permit No. 6765.

c. Characteristics.

(1) **Grade A Helium.** Grade A helium gas is 99.995 percent pure helium, containing less than 50 parts per million volume (ppmv) of impurities. Pure helium is a monoatomic gas that is chemically inert, highly permeable, colorless, odorless, tasteless, noncorrosive, and nonflammable. Other characteristics are as follows:

<u>Characteristics</u>	<u>Value</u>
Chemical formula	He
Chemical family	rare gas
Molecular weight	4.0026
Normal boiling point	
at 14.696 psia (0.101 33 MPa [absolute])	-452.1° F (-268.9°C)
Freezing point	
at 14.696 psia (0.101 33 MPa [absolute])	none
at 367.4 psia (2.53 MPa [absolute])	-458.0° F (-272.2°C)
Specific volume	
at 70° F, 14.696 psia	96.71 cu ft/lb
Weight density - gas	
at 70° F, 14.696 psia	0.010 34 lb/cu ft
Weight density - liquid	
at normal boiling point	7.798 lb/cu ft (125.1 kg/m ³)
Specific gravity (air = 1)	
at 70° F, 14.696 psia	0.137 96
Individual gas constant	386
Specific heat at 70° F, 14.696 psia	
at constant pressure	1.25 Btu/lb-° F
at constant volume	0.75 Btu/lb-° F

Helium diffuses more rapidly, conducts heat more rapidly, and transmits sounds faster than any gas except hydrogen.

MIL-HDBK 1024/2

(2) Impure Helium. Helium gas is considered impure when the content is less than 98 percent helium by volume. The purity of impure helium gas has been reduced when air, oxygen, hydrocarbon, water vapor, or other contaminants are present. Impure helium may be repurified using the repurification methods described in this design manual.

MIL-HDBK 1024/2

Section 2. PLANT AND STORAGE DESIGNS

1. **RECEIVING FACILITIES.** Provide high pressure grade A helium receiving facilities as required by the shipping method used. Container capacities are detailed in Section 1. Provide impure helium receiving facilities if impure helium is shipped to the plant.

a. Rail Spur. Provide a rail spur connected by piping to the high pressure storage cylinders, booster compressor station, truck trailer station, and transfer shop where deliveries are made by rail. It is recommended that the length of the spur be sufficient to hold a train of tank cars having a capacity equal to the total capacity of the high pressure storage cylinders. Design rail spurs to comply with NAVFAC DM-5.06, Civil Engineering Trackage, and the American Railway Engineering Association (AREA) publication, Manual For Railway Engineering.

b. Truck Trailer. Provide a truck unloading point connected by piping to the high pressure storage cylinders, the booster compressor station, and the transfer shop where deliveries are made by truck.

c. Compressor Station. Generally, the initial filling of the high pressure storage cylinders from the shipping container is by pressure equalization.

(1) Receiving Compressors. Provide a receiving compressor for unloading shipping containers and for boosting the pressure in the high pressure storage cylinders.

(2) Compressor Design. Nonlubricated multi-stage reciprocating or diaphragm compressors (Class NL-1 or NL-2) are recommended. Compressors shall be water cooled, with intercoolers and aftercoolers. Lubricated compressors (diaphragm or piston displacement) may be used if coalescing oil filters are installed on the compressor discharge to prevent contamination of the helium by hydrocarbons. Minimize compressor noise and vibration in accordance with NAVFAC DM-3.10, Noise and Vibration Control for Mechanical Equipment. Facility operating requirements will determine compressor capacity and pressures. For example, a typical receiving compressor might be required to handle a capacity of 60 standard cubic feet per minute (scfm), with a minimum suction pressure of 0.5 psig and a maximum discharge pressure of 2,600 psig. If the project must also be designed for hydrogen storage in the future, the compressors must be suitable for hydrogen handling.

2. **STORAGE FACILITIES.** Requirements for helium gas storage are as follows:

a. Storage Capacity. Storage capacity requirements are normally stated by volume in scf (volume of gas at 70° F and 14.696 psia).

MIL-HDBK 1024/2

(1) **Capacity Requirements.** Base the storage capacity requirements for grade A and impure helium on the quantity and frequency of grade A helium delivered, the quantity and frequency of impure helium repurified, and the prediction of grade A helium usage and impure helium production. Storage capacity based on prediction of usage and production shall be approximately 10 percent in excess of that necessary for a project phase. The following are examples of project phases:

(a) The storage requirements for a supersonic wind tunnel shall be for one blowdown cycle.

(b) In a once-through cooling system for a rocket engine, the requirement between initial and final pressures shall be one test run, with replenishment available at the receiving station for the next test.

(2) **Storage Pressure and Cylinder Quantity.** Cylinder storage pressure is determined by system pressure requirements, or by an economical combination of the storage pressure and the total number of cylinders. The storage pressure and number of cylinders combined must satisfy the total volumetric capacity requirements. A greater number of storage cylinders are required as the storage pressure decreases. For example, a storage pressure of 1,200 psig requires twice as many cylinders to store the same quantity of helium when compared to the storage pressure of 2,400 psig.

b. High Pressure Storage Cylinders. High pressure helium is stored in the multiple high pressure cylinders. Cylinders are also referred to as tanks.

(1) **Cylinder Design.** Cylinders offered for transportation by air, highway, railroad, or water must conform with Department of Transportation (DOT) requirements 49 CFR 173, Transportation - Shippers - General Requirements for Shipments and Packaging, and 178. Commercially manufactured cylinders are readily available in various sizes and pressure ratings. Periodic hydrostatic pressure retests must be performed and certified on all DOT specified cylinders in accordance with 49 CFR 173.34. Retests are not required on cylinders designed in accordance with the American Society of Mechanical Engineers (ASME) Code. Typical commercial cylinder markings are shown in Figure 1.

MIL-HDBK 1024/2

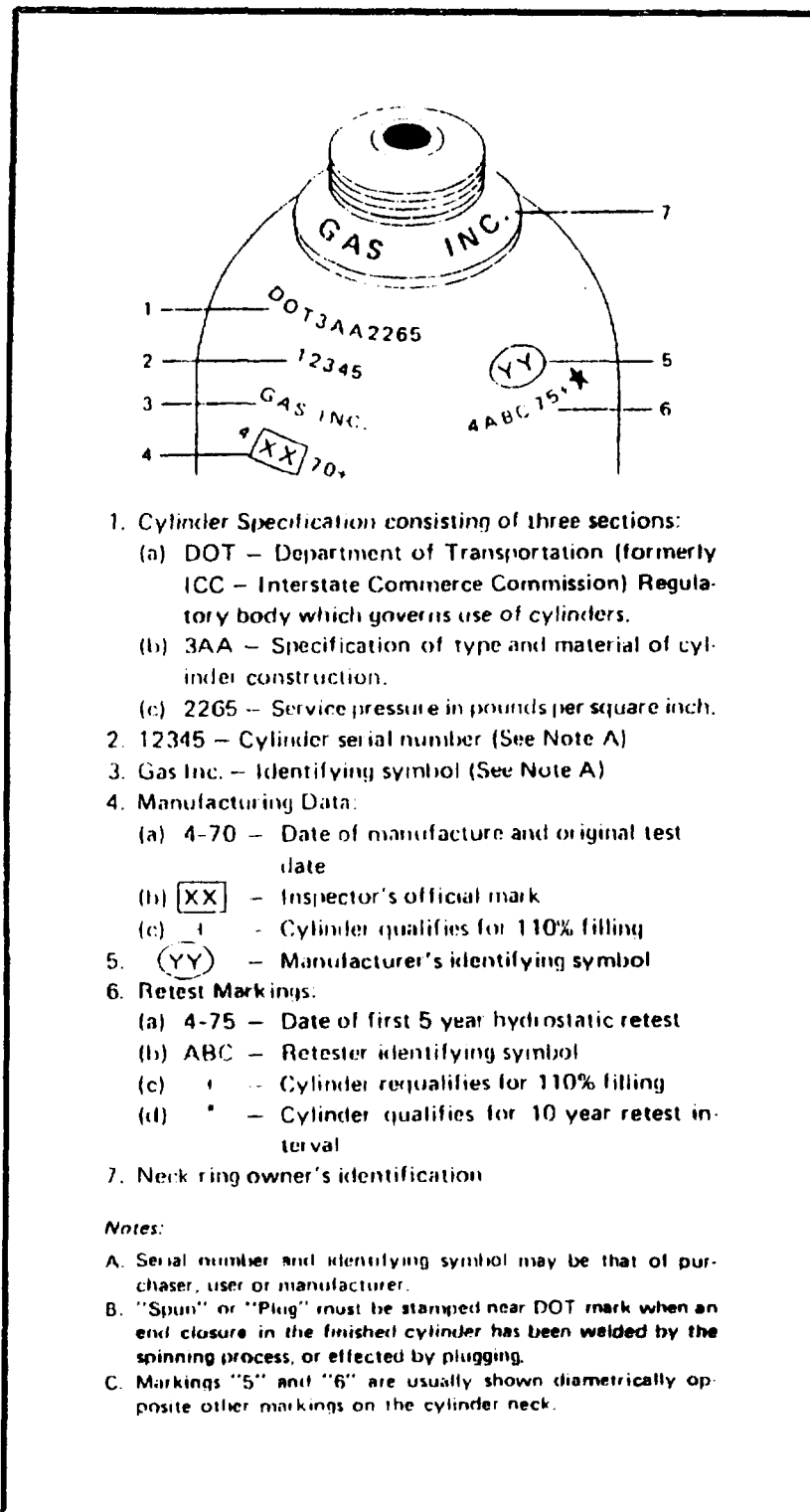

1. Cylinder Specification consisting of three sections:
 - (a) DOT – Department of Transportation (formerly ICC – Interstate Commerce Commission) Regulatory body which governs use of cylinders.
 - (b) 3AA – Specification of type and material of cylinder construction.
 - (c) 2265 – Service pressure in pounds per square inch.
2. 12345 – Cylinder serial number (See Note A)
3. Gas Inc. – Identifying symbol (See Note A)
4. Manufacturing Data:
 - (a) 4-70 – Date of manufacture and original test date
 - (b) XX – Inspector's official mark
 - (c) + – Cylinder qualifies for 110% filling
5. YY – Manufacturer's identifying symbol
6. Retest Markings:
 - (a) 4-75 – Date of first 5 year hydrostatic retest
 - (b) ABC – Retester identifying symbol
 - (c) + – Cylinder requalifies for 110% filling
 - (d) * – Cylinder qualifies for 10 year retest interval
7. Neck ring owner's identification

Notes:

- A. Serial number and identifying symbol may be that of purchaser, user or manufacturer.
- B. "Spun" or "Plug" must be stamped near DOT mark when an end closure in the finished cylinder has been welded by the spinning process, or effected by plugging.
- C. Markings "5" and "6" are usually shown diametrically opposite other markings on the cylinder neck.

Figure 1
Compressed Gas Cylinder Markings

MIL-HDBK 1024/2

(2) **Cylinder Storage.** Helium cylinders may be stored indoors or outdoors. A canopy or roof may cover the cylinders stored outdoors to assist in corrosion and temperature control. Cylinders may be stacked horizontally or arranged vertically, with the piped ends facing a common manifold. Install large horizontal cylinders (minimum volume approximately 15 cubic feet) with a three-degree slant, and provide a lower-end drain valve. All cylinders shall be physically secured with a rack, a chain fastener, or a similar device. It is recommended that cylinders not be subjected to ambient temperatures over 130° F. Consider the effects of sun, frost, or other temperature variables on the internal cylinder pressure when determining the maximum allowable working pressure. See the following table for examples of internal pressure variation with temperature change.

Cylinder Temperature (°F)	Cylinder Pressure, psig		
	Minimum	Normal	Maximum
-50	1,393	1,755	2,046
32	1,672	2,104	2,453
70	1,800	2,265	2,640
100	1,901	2,391	2,787
130	2,001	2,517	2,933
150	2,069	2,601	3,031

c. **Impure Helium Collection and Storage.** Provide a reserve holder for capturing used helium gas so that it may be repurified. Figure 2 is a block flow diagram (BFD) of a typical impure helium collection and storage system. Figure 3 is a piping and instrument diagram (P&ID) of the same system. Figures 4A, 4B, and 4C contain explanatory and symbols for Figure 3. The helium from one or more impure gas collecting stations is stored in a low pressure gas bag (0-5 psig). The impure gas is periodically compressed and transferred by a multi-stage compressor from the full low pressure gas bag into the high pressure storage cylinders. High and low gas bag level limit switches provide information that activates the compressor when the gas bag is full. Pressure in the high pressure storage cylinders will drop as the impure helium is transferred to the repurification plant or other destination. Recycle this impure helium back through the compressor when the cylinder storage pressure falls below the transfer pressure requirements. The following compressor variables result in compressor alarm and shutdown whenever the set points for any variable are exceeded: compressor motor speed (RPM); compressor oil pressure; compressor bearing housing cooling water temperature; suction pressure; impure helium gas temperature and pressure at each compressor interstage and the aftercooler; cooling water temperature discharging from each intercooler and the aftercooler. At the supersonic wind tunnel installation for the Ames Research Center, the impure gas was stored in closed vacuum spheres (2-14.7 psia).

d. **Shipping Containers.** Shipping containers such as truck trailers, railroad tank cars, and liquid helium Dewar flasks may be used for temporary or convenient storage.

MIL-HDBK 1024/2

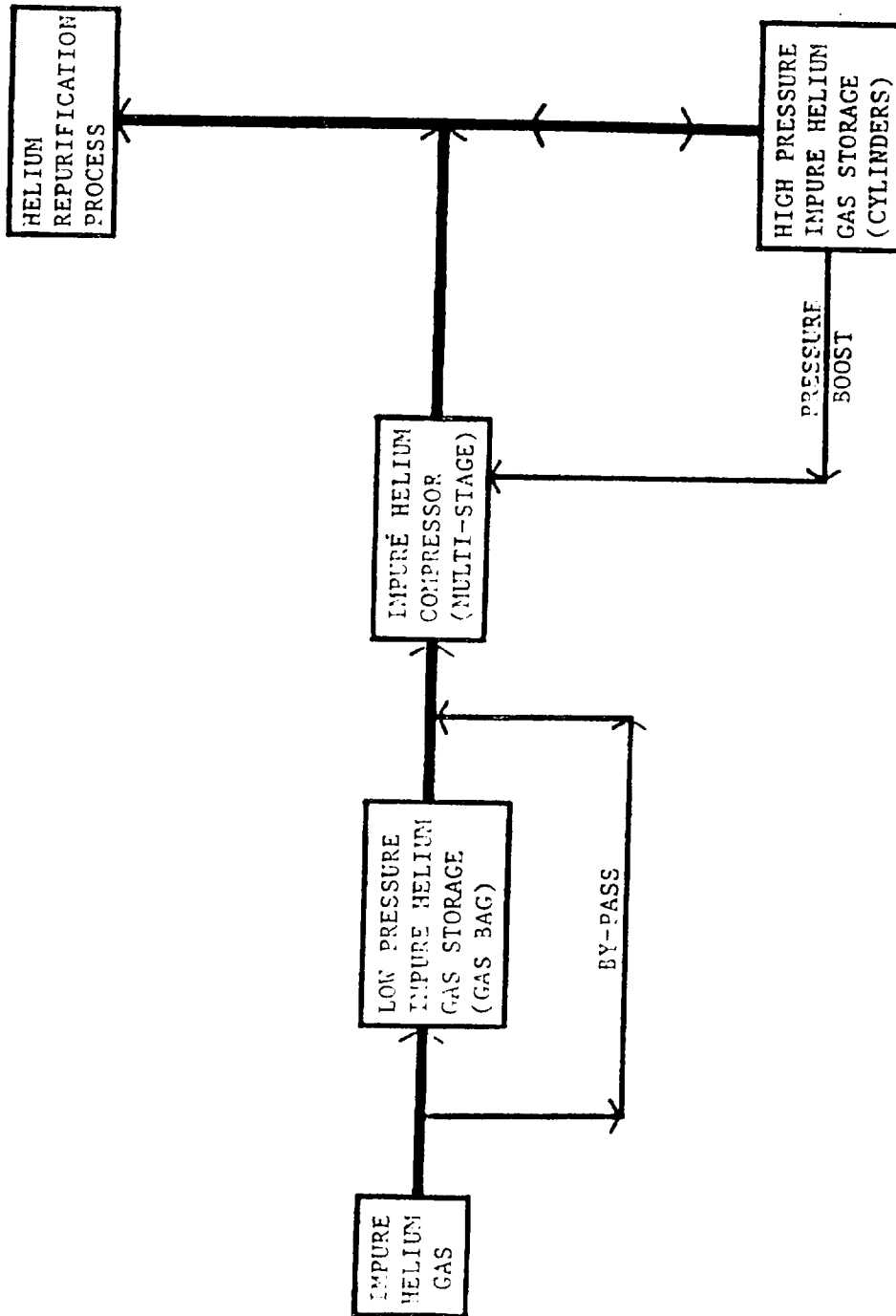

Figure 2
Block Flow Diagram: Impure Helium Collection and Storage System

MIL-HDBK 1024/2

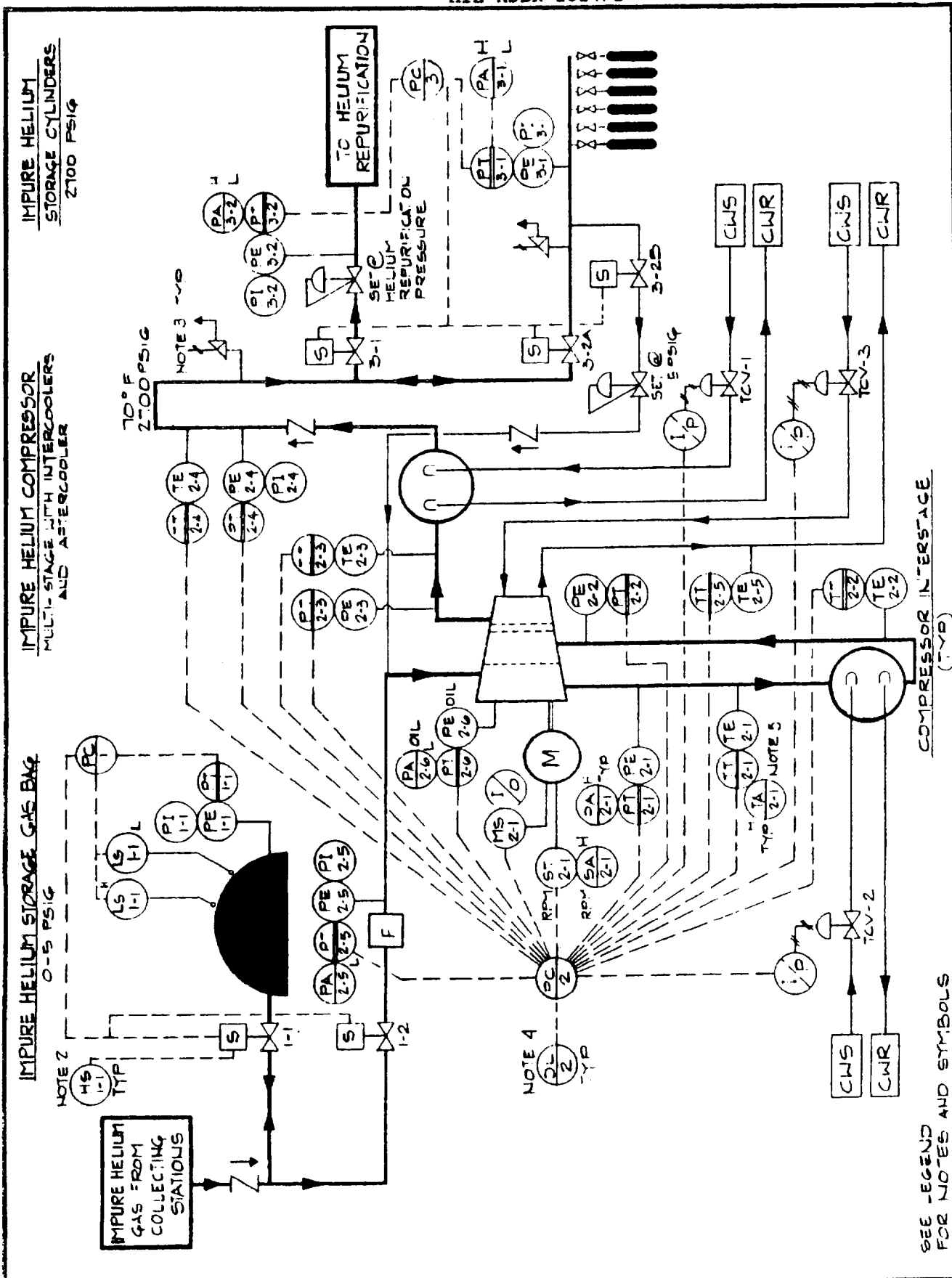

Figure 3
 Piping and Instrument Diagram: Impure Helium Collection and Storage System

NOTES

1. Provide block valves and bypass lines for all control valve stations. Provide block valves for servicing all parallel equipment.
2. Provide a local key-operated pushbutton hand switch (HS) at each solenoid valve (SOV).
3. Vent all relief valves to the impure helium collection header unless noted otherwise.
4. Provide a data logger (DL) to periodically scan and record all process variables in programmable controller (PC) control loops.
5. Provide high temperature and pressure alarms at compressor outlet for each stage.

SYMBOLS











	Local Mounted Instrument		Alarm Low
	Control Center Board Mounted Instrument		Alarm High and Low
	Local Panel Mounted Instrument		Multichannel Programmable Controller
	XX --- Instrumentation and Control Functional Designation Y --- Instrumentation or Control Loop Number Z --- Instrument Item Number		Multichannel Data Logger
	Alarm High		Liquid Level Element

Figure 4A
 Legend, Piping and Instrument Diagram Notes and Symbols

MIL-HDBK 1024/2

SYMBOLS



Liquid Level Transmitter



Analyzer Element



Limit Switch High



Analyzer Recorder



Limit Switch Low



Analyzer Transmitter



Pressure Element



Flow Element



Pressure Indicator



Flow Transmitter



Pressure Transmitter



Hand Switch, Key Operated



Differential Pressure Element



Electric to Pneumatic Signal Converter



Differential Pressure Transmitter



Electric Motor



Differential Pressure Indicator



Electric Motor Starter



Temperature Element



Rotation Speed Transmitter



Temperature Transmitter



On-Off Switch

FIGURE 4B
 Legend, Piping and Instrument Diagram Notes and Symbols

SYMBOLS















	Filter		Solenoid Valve
	Cooling Water Supply		Automatic Control Valve
	Cooling Water Return		Pressure Regulator
	Relief Valve		Joule-Thompson Expansion Valve
	Vacuum Rupture Disc		Pneumatic Signal
	Check Valve		Electrical Signal
	Restriction Orifice		Trap

Figure 4C
 Legend, Piping and Instrument Diagram Notes and Symbols

MIL-HDBX 1024/2

e. Portable Storage. Use K-bottle cylinders (approximately 1.5 cubic feet) or other conveniently sized cylinders for high-pressure, low-capacity portable storage. Use truck trailers for high-pressure, high-capacity portable storage, especially when service points are not accessible to the helium distribution piping system.

3. REPURIFICATION PLANTS. Repurify impure helium gas when economically or strategically justifiable. The purity of the helium gas is reduced when air, water vapor, hydrocarbons, or other contaminants are present. With repurification, purchased helium is needed only to make up the loss due to leakage and purging. The following established repurification methods are described in this section: (a) cryogenic adsorption; (b) pressure swing adsorption; and (c) separation by air expansion. Cryogenic adsorption is the most widely used repurification method. Higher degrees of helium purity are more easily attained with cryogenic adsorption than with other methods, but a liquid nitrogen supply is required and may cause unique cryogenic maintenance problems. Pressure swing adsorption is a relatively new repurification method, with ambient operating temperatures resulting in lower maintenance requirements. Separation by air expansion is an efficient repurification method only when the impure helium feed has helium as the minority component, with air or natural gas as the majority component. Examples of past or present repurification plants are presented with each description.

a. Cryogenic Adsorption.

(1) Procedure. Cryogenic adsorption is the most widely used repurification method. Higher degrees of helium purity are more easily attained with cryogenic adsorption than with other methods, but a liquid nitrogen supply is required and can cause unique cryogenic maintenance problems. Cryogenic adsorption is a liquid nitrogen cooled process capable of producing helium of at least grade A purity. The operating pressures range from medium to high (400-2,600 psig), depending upon the repurified helium end-use pressure requirements. Higher adsorption column pressure generally results in higher column efficiency. Impurities are removed from the cooled impure helium gas by phase separation in a liquid nitrogen cooled separator and then by adsorption in a liquid nitrogen cooled, activated charcoal adsorption column. Phase separation is practical due to the widely varying boiling points of the helium and contaminants. A BFD and a P&ID of a cryogenic adsorption repurification process are shown on Figures 5 and 6. The University of Pennsylvania, Philadelphia, uses a low capacity cryogenic adsorption package unit to repurify research laboratory helium. The low capacity unit is designed to process 750 scf per hour (scfh) of impure helium containing 80 percent helium and 20 percent air. This package unit operates at a working pressure of 1,400 psig, yielding grade A helium gas with 99.995 or greater percent pure helium. A high capacity cryogenic adsorption plant was used in the past at the Ames Research Center, NASA, Moffett Field, California, to repurify helium for wind tunnel atmosphere mixtures. This plant was designed to process 30,000 scfh of impure helium containing 80 percent helium and 20 percent air. The Ames plant operated at a working pressure of 2,500 psig, yielding a product gas with greater than 98.5 percent pure helium.

MIL-HDBK 1024/2

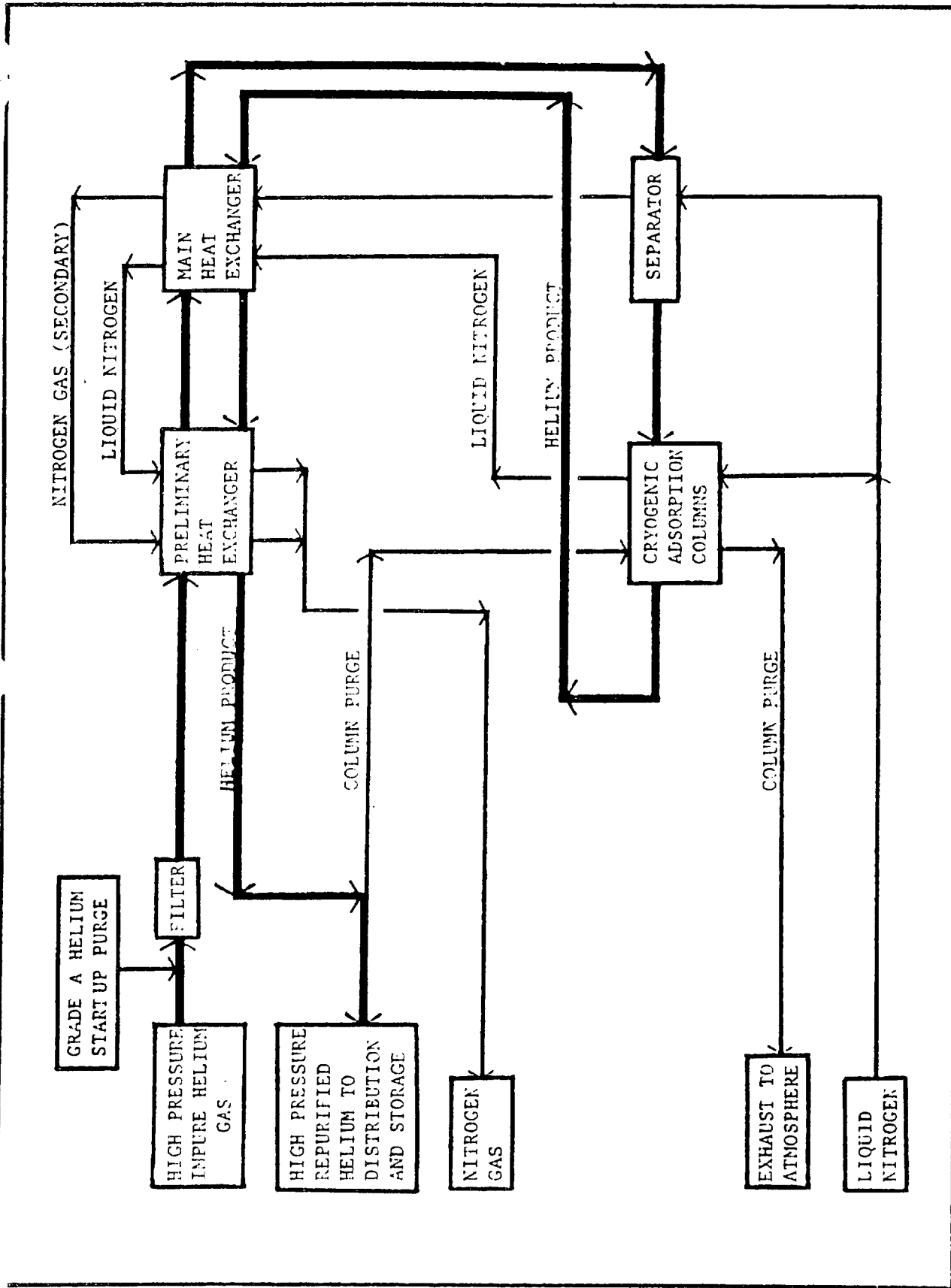

Figure 5
Block Flow Diagram: Cryogenic Adsorption Repurification Process

MIL-HDBK 1024/2

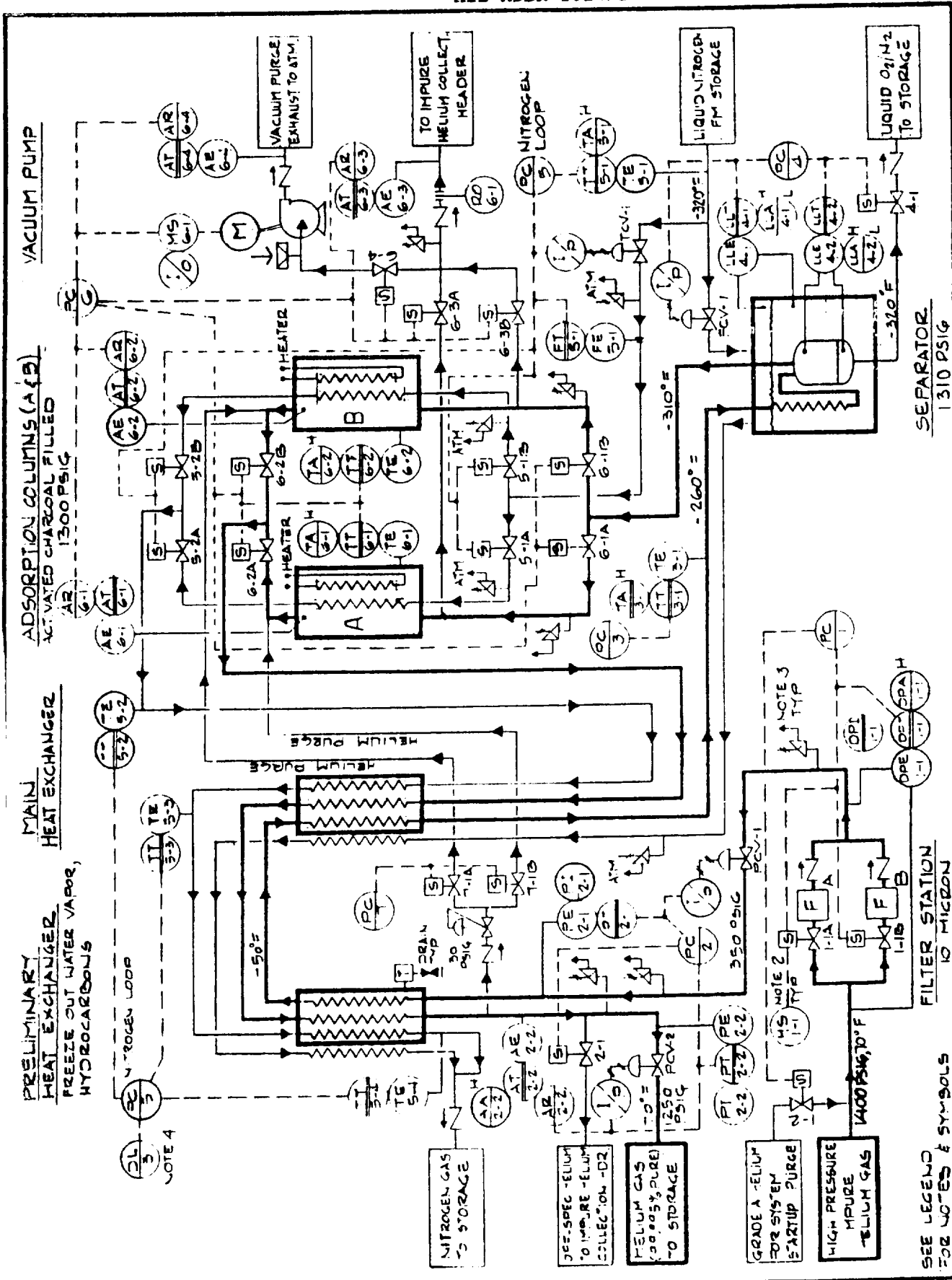

Figure 6
 Piping and Instrument Diagram: Cryogenic Adsorption Repurification Process

(a) Impure Helium Supply. Impure helium is collected and stored in high pressure storage cylinders. High pressure impure helium is then transferred to the repurification plant at 1,400 psig. See Figures 2 and 3 for a typical impure helium transfer to the repurification plant. When the storage cylinder pressure drops below the repurification plant requirements, the impure helium is routed back to the compressor inlet to boost the pressure.

(b) Filters and Heat Exchangers. The 1,400 psig impure helium first passes through a filter station to remove particles 10 microns or larger. The process flow is switched between the parallel filters when an increase in pressure drop across the operating filter indicates that it has become saturated with contaminants. The incoming impure gas is chilled in two heat exchangers by countercurrent flows of liquid nitrogen and repurified helium gas. The impure gas is first chilled to approximately -50° F in the preliminary heat exchanger, freezing out any water vapor or hydrocarbons. The main heat exchanger then further chills the impure gas to approximately -260° F. The vaporized nitrogen line from the separator is coiled around the heat exchangers to provide energy-efficient thermal insulation.

(c) Separator. The chilled impure helium now enters the inner chamber of the liquid nitrogen cooled separator, where liquefied contaminants in excess of 0.15 percent oxygen and 1.85 percent nitrogen are separated out of the gas stream. The helium gas leaving the top of the separator has been chilled to -310° F and is approximately 98 percent pure helium. The liquefied contaminants from the helium stream are collected in the bottom of the separator's inner chamber, and the contaminants are periodically drained away. A constant level of liquid nitrogen is maintained in the separator's outer chamber.

(d) Activated Charcoal Adsorption Columns. The helium now enters one of the two parallel liquid nitrogen cooled, activated charcoal filled adsorption columns. The chilled activated charcoal adsorption bed retains most of the contaminants remaining in the helium gas. The 99.995 percent pure helium gas leaves the adsorption column at approximately -320° F and 1,300 psig and is routed through the countercurrent heat exchangers to chill the incoming impure gas. Pressure control valve PCV-2 controls the process pressure by maintaining a system backpressure of 1,250 psig. The repurified helium gas is stored at approximately 70° F and 1,250 psig.

(2) Helium Purity Analysis. A gas chromatograph analyzer continuously analyzes the repurified helium product. The analyzed results are recorded automatically. (A mass spectrometer analyzer is an acceptable substitute.) The repurified helium discharge flow is switched to the impure helium collection header if the helium quality falls below the product specification when processing through a clean column. This is an abnormal condition and may require process shutdown.

MIL-HDBK 1024/2

(3) Adsorption Column Regeneration. The operating adsorption column is regenerated when the column gas analyzer detects contaminant saturation. The impure helium feed and liquid nitrogen supply are switched to the parallel clean column while the first column is being regenerated. Regeneration is a three step process. First, the regenerating column is depressurized and vented in the reverse flow direction to the impure helium collection header for later repurification. Restriction orifice RO 6-1 slows column depressurization, as unregulated rapid depressurization may damage the activated charcoal in the columns. Second, the heater is activated and warms the column to approximately 50° F, thus releasing most of the retained contaminants from the activated charcoal. Third, the vacuum pump and a reverse flow purge of repurified helium are activated. The grade A helium purge removes most of the warmed contaminants from the adsorption column and vents them to the atmosphere. The vacuum pump is protected by a rupture disk in the suction piping.

(4) Liquid Nitrogen Supply. Liquid nitrogen is supplied to maintain the required level in the outer chamber of the separator. Liquid nitrogen is also routed through the adsorption columns and then back through the heat exchangers. Temperature control valve TCV-1 modulates the liquid nitrogen inlet flow rate. By design, this countercurrent flow of liquid nitrogen should have just completely vaporized as it leaves the preliminary heat exchanger.

(5) Startup and Shutdown. Purge the system of contaminants using grade A helium prior to startup. During shutdown, the helium in the system is vented to the low pressure impure helium collection header for later repurification.

b. Pressure Swing Adsorption (PSA).

(1) Procedure. Pressure swing adsorption is a relatively new repurification method, with ambient operating temperatures resulting in lower maintenance requirements. Pressure swing adsorption (PSA) is a medium to high pressure, molecular sieve adsorption process using a pressure swing cycle for adsorption column regeneration. Figure 7 is a BFD and Figure 8 is a P&ID of a PSA repurification process. A PSA plant is used by the Navy Experimental Dive Unit (NEDU), Panama City, Florida, to repurify helium used in simulated-dive breathing mixtures. The total purification rate at the NEDU facility is 20 scfm, yielding helium with a purity of between 99.5 and 99.997 percent.

(a) Impure Helium Supply. Impure helium is collected and stored in high-pressure storage cylinders to await repurification. See Figures 2 and 3 for a typical impure helium collection and storage system. A four-stage compressor boosts the impure helium pressure to 2,500 psig and transfers it to the repurification plant.

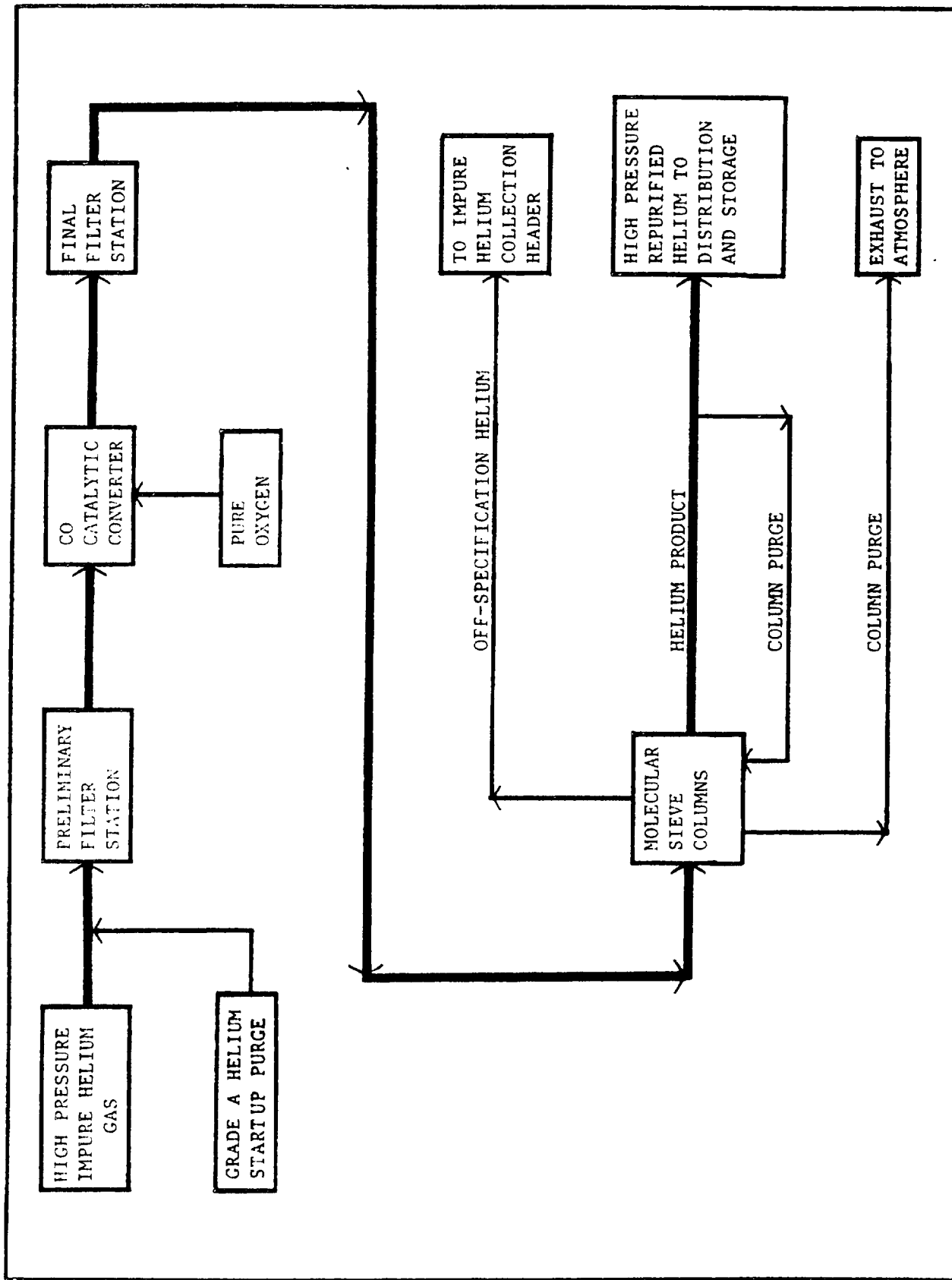

Figure 7
Block Flow Diagram: Pressure Swing Adsorption Repurification Process

MIL-HDBK 1024/2

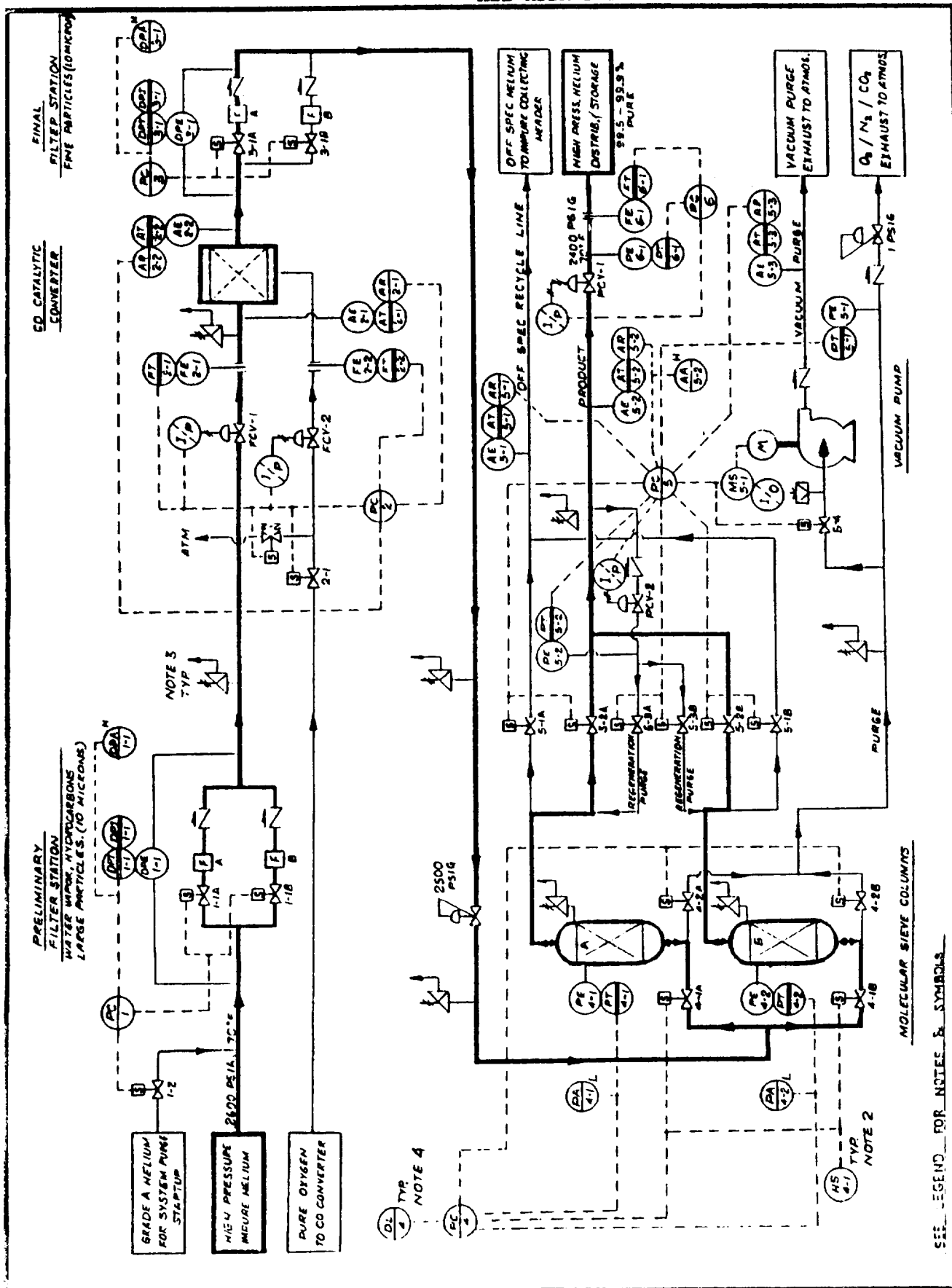

Figure 8
 Piping and Instrument Diagram:
 Pressure Swing Adsorption Repurification Process

MIL-HDBK 1024/2

(b) Filters and Carbon Monoxide (CO) Converter. The high pressure impure helium passes through a series of filters to remove water vapor, hydrocarbons, carbon dioxide, and large particles (10 microns or larger). The process flow is switched between the parallel filters when an increase in pressure drop across the operating filter indicates that it has become saturated with contaminants. The water vapor and hydrocarbon filter contains a molecular sieve adsorbent. (Activated alumina is also an acceptable adsorbent.) Figure 8 shows only one typical preliminary filter station. Next, the gas passes through a CO converter to convert the carbon monoxide to carbon dioxide. Proportional impure helium and oxygen flow rates are maintained using a gas analyzer to achieve optimal carbon dioxide conversion. The fine particle filter then removes small particles (1 micron or larger) in the impure helium stream. The remaining contaminants are now primarily oxygen, nitrogen, and carbon dioxide.

(c) Molecular Sieve Adsorption Columns. The high pressure impure helium gas is passed through one of the two parallel molecular sieve adsorption columns. The molecular sieve retains the oxygen, nitrogen, and carbon dioxide contaminants, while the pure helium gas (99.5-99.997 percent pure) is routed to storage at 2,400 psig and 70° F. Pressure control valve PCV-1 maintains the system pressure.

(2) Helium Purity Analysis. The impurities in the helium product are continuously monitored by a gas chromatograph analyzer at the discharge of the helium product stream. Adsorption column regeneration is triggered when the quality of the repurified helium discharge flow falls below the product specification. If the helium composition continues to remain below specification, the discharge stream is switched to the impure helium collection header. This is an abnormal condition and may require process shutdown. The analyzer is accurate within the purity range produced by the process.

(3) Adsorption Column Regeneration. Regeneration is a four-stage depressurization and purge process. Column regeneration begins when the gas analyzer indicates that the column has become saturated. Contaminants are released from the molecular sieve during depressurization, hence the term "pressure swing adsorption." First, the pressure is equalized between the two adsorption columns. Second, the impure helium feed is switched to the clean column and resumes processing, while the off-spec helium still in the regenerating column is recycled back to the impure helium collection header for later repurification. Third, the regenerating column is vented to the atmosphere, releasing most of the trapped contaminants. This venting is done in a reverse flow direction, with the contaminants discharging from the column inlet. Fourth, a vacuum pump draws the column down to 20 inches of water (0.72 psia), again in the reverse flow direction. With the vacuum pump still operating, a low flow of repurified helium is introduced to complete the purge of the column. A gas analyzer triggers the end of the vacuum purge. The vacuum pump is protected by a rupture disk in the suction line.

MIL-HDBK 1024/2

(4) Startup and Shutdown. Purge the system of contaminants using grade A helium before startup. The pressure regulator prior to the adsorption columns prevents startup processing until minimum column pressure has built up. During shutdown, the system is vented to the low pressure impure helium collection header for later repurification. Block and bleed the pure oxygen line at shutdown to eliminate a potential combustion or explosion hazard.

(5) Compressor Characteristics. A four-stage, reciprocating, nonlubricated positive displacement compressor is used. Intercoolers, aftercooler, and relief valves are provided.

c. Separation by Air Expansion.

(1) Procedure. Separation by air expansion repurifies helium by chilling the impure gas, condensing the impurities, and then separating the phases. An expansion turbine and Joule-Thompson throttling valves are used to expand liquid air to provide process refrigeration. This repurification method requires that helium be the minority component in a mixture with a gas that cools significantly when expanded at room temperature or less (e.g., air and natural gas). Separation by air expansion is particularly efficient when the helium content in the impure feed gas is less than 30 percent by volume. Due to these impure feed gas restrictions, this repurification method is used much less often than the other repurification methods discussed in this section. Separation by air expansion has not been used for helium repurification since 1970. A similar process is currently in use commercially to initially extract helium from natural gas. A BFD and a process flow diagram (PFD) are shown on Figures 9 and 10. No P&ID is provided, as the PFD more clearly presents the concept of this complex process. Basic automation principles are similar to those applied in the cryogenic repurification method. This method was used by the Ames Research Center to repurify helium for the supersonic wind tunnel. The Ames plant operated low and high pressure stages (165 and 3,050 psia), producing a 99.5 percent pure helium product. Helium expansion characteristics cause the gas temperature to rise when it is expanded at temperatures above -387° F. The Ames plant could tolerate a maximum feed concentration of 18 percent helium by volume. When the helium concentration rose above 18 percent, it was necessary to dilute the feed with product air, thus providing sufficient air for driving the turbine and providing process refrigeration.

(a) Impure Helium Supply. The impure helium-air mixture is collected and stored in vacuum spheres after each wind tunnel blowdown cycle. The impure gas is then evacuated from the vacuum spheres, compressed to 165 psia, and transferred to the plant for repurification by a two-stage feed gas compressor.

MIL-HDBK 1024/2

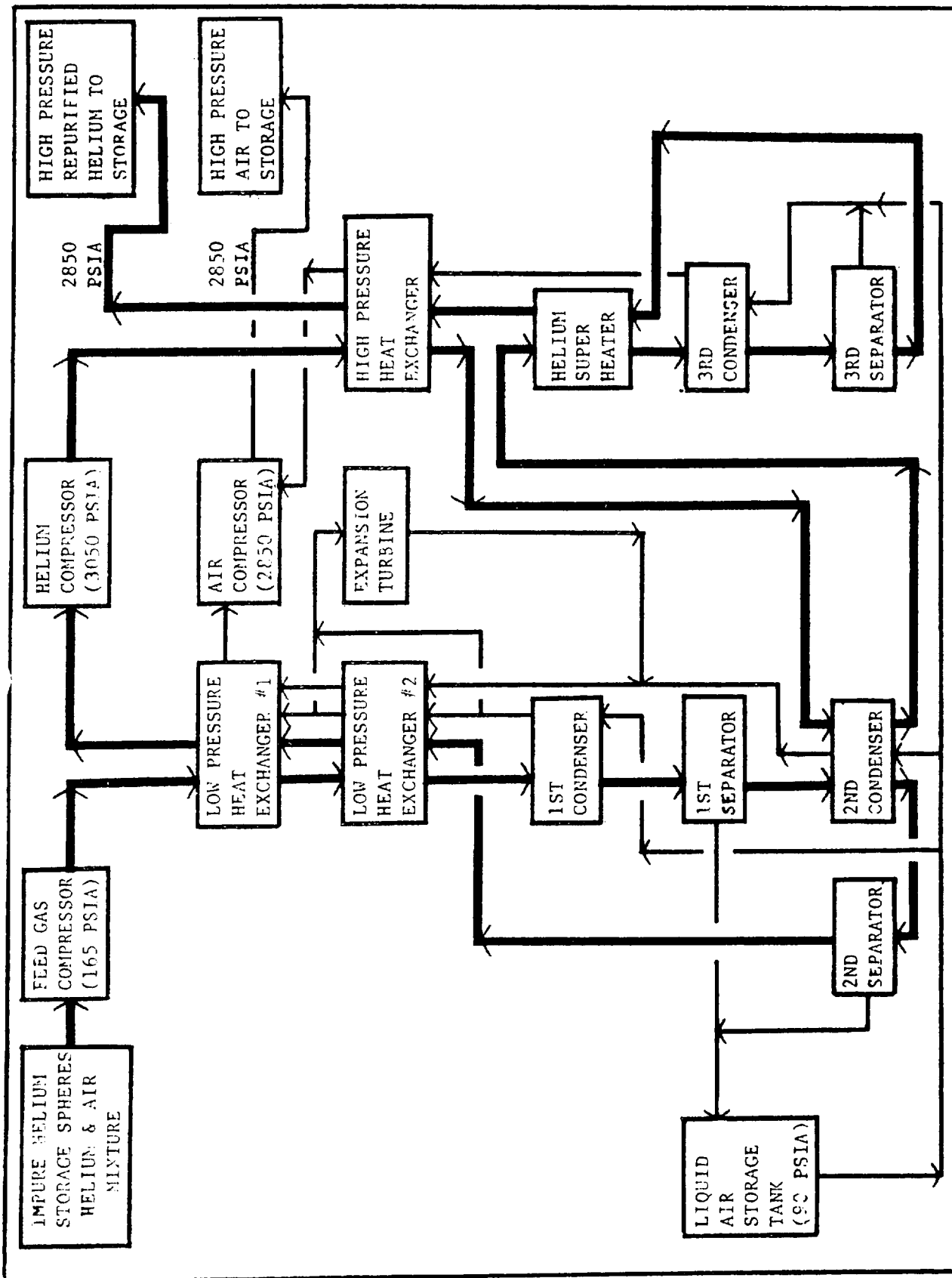

Figure 9
 Block Flow Diagram: Separation by Air Expansion Repurification Process

MIL-HDBK 1024/2

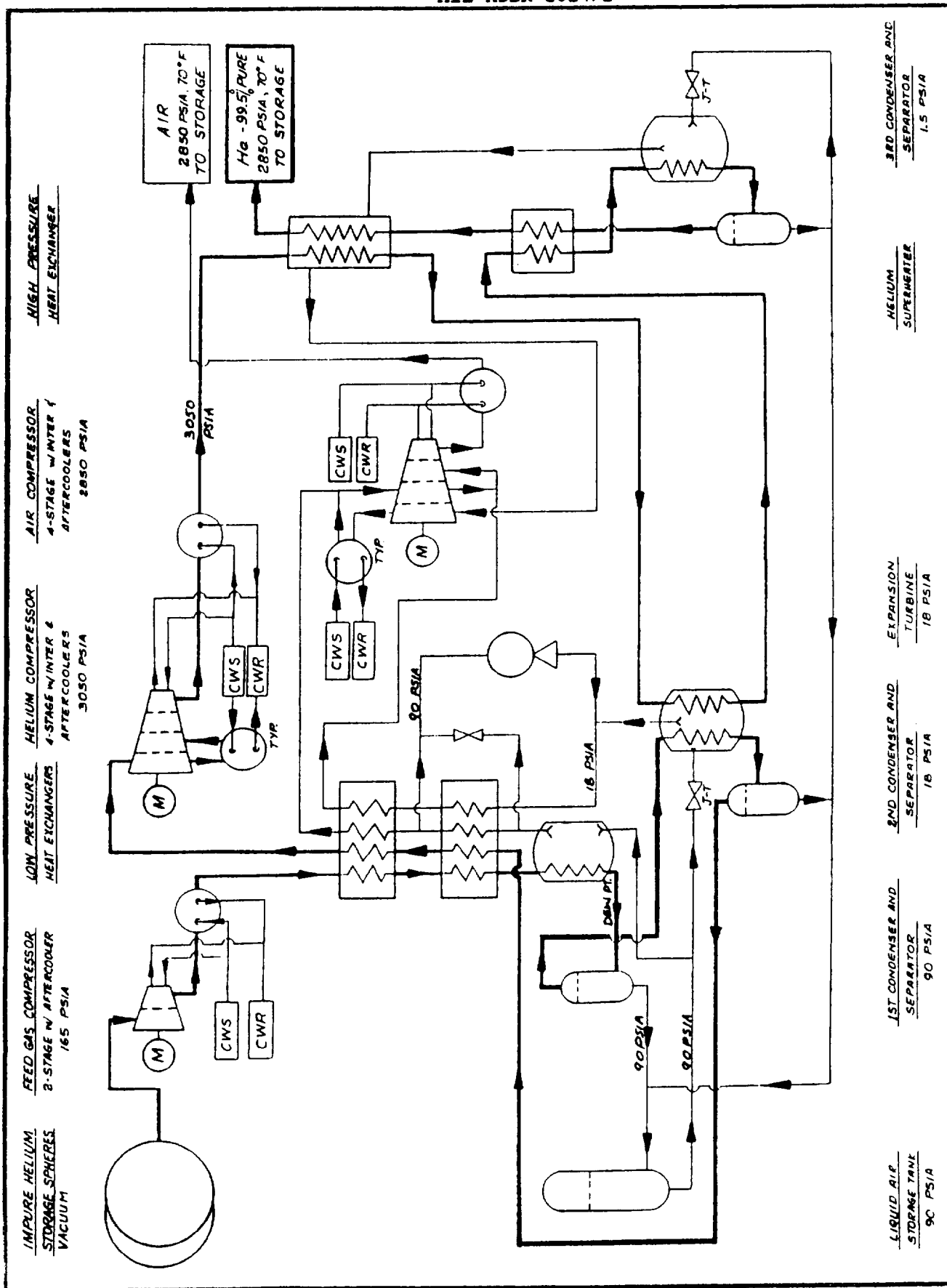

Figure 10
 Process Flow Diagram: Separation by Air Expansion Repurification Process

MIL-HDBK 1024/2

(b) Helium-Air Separation. Separation of air from helium is accomplished in three stages of air condensation and separation. The impure gas is first cooled in two countercurrent low-pressure heat exchangers to the dew point of the mixture. The gas then passes through the first condenser, where it is further cooled and where approximately 75 percent of the air is condensed. This gas-liquid mixture now enters the first separator, where initial separation of air and helium occurs. The impure helium gas continues on to the second condenser, where it is cooled still further and more air is condensed. The gas-liquid mixture then enters the second separator for phase separation. The liquid air from each separator is fed to the liquid air storage tank. The helium gas from the second separator then flows back through the low-pressure heat exchangers, cooling the incoming impure gas. The helium gas is now compressed to 3,050 psia by a four-stage compressor. Next, the gas is cooled consecutively in the high-pressure heat exchanger, second condenser, helium superheater, and third condenser. Most of the remaining air is now condensed. Final phase separation occurs in the third separator. The repurified helium gas (approximately 99.5 percent helium) passes back through the helium superheater and high-pressure heat exchanger, and is discharged to storage at roughly 2,850 psia and 70° F.

(c) Air Expansion. Air is the primary contaminant in the impure helium gas. Expanding air causes it to cool significantly, providing the required process refrigeration. The air in the incoming impure gas is chilled in the heat exchangers, condensed, separated from the helium gas, and collected in the liquid air storage tank at 90 psia. Chilled liquid air at 90 psia passes back through the first condenser and the low pressure heat exchangers, providing some cooling of the incoming impure gas. A portion of the 90 psia air is diverted after the first low pressure heat exchanger and is passed through an expansion turbine. The air is greatly chilled as it expands from 90 psia to 18 psia, providing much of the refrigeration required by the low pressure heat exchangers. (A small flow of the 90 psia air is bypassed before the first low-pressure heat exchanger and is added to the turbine inlet to regulate the turbine outlet temperature.) Some of the process cooling results from 90 psia liquid air being throttled through a Joule-Thompson (J-T) expansion valve into the second condenser at 18 psia, and into the third condenser at 1.5 psia. This expanded and chilled air then passes from the second or third condenser through either the low- or high-pressure heat exchanger, helping to cool the incoming streams. The air is then compressed to 2,850 psia by a four-stage compressor and stored for reuse.

d. Interlocked Automatic Control Systems. Develop interlocked automatic control systems for the process during the detailed engineering design phase. A programmable controller (PC) is recommended to monitor, initiate, and carry out process control using interlocked control loops. Develop a logic sequence to incorporate automatic process alarm and shutdown into the control system.

4. DISTRIBUTION AND INTERCONNECT SYSTEMS. Prepare drawings and specifications in accordance with the NAVFAC DM-6 Series. Provide distribution and interconnect drawings, piping, and design details as follows:

MIL-HDBK 1024/2

a. Block Flow Diagram. Provide a block flow diagram (BFD) for the process. Show the overall process flow, including each piece of equipment and all major process steps. Add a material balance and a heat balance to the block flow diagram during the detailed engineering design phase. Use detailed data based on the particular impure helium feed composition, the plant location, and specific process options and requirements.

b. Piping and Instrument Diagram. Provide a P&ID for the process, following the guidelines presented in Instrument Society of America (ISA) S.51, Instrumentation Symbols and Identification. Show process piping, equipment, valving, instrumentation, and control system. Include piping that allows equipment and pipes to be purged with grade A helium prior to process startup. Include piping that allows helium to be evacuated from the equipment and pipes during process shutdown so that it may be reclaimed.

c. Piping Plan. Provide a piping plan, including an interconnecting piping layout, piping elevations, and isometric piping drawings.

d. Distribution and Interconnect Piping. Route distribution and interconnect piping to minimize the overall length required for the service.

(1) Connections. Provide mechanical flexibility through bends, loops, and changes in direction. Connect each storage cylinder to the storage cylinder manifold through an on-and-off valve. Do not use this valve for throttling flow. Use a globe or flow control valve on the cylinder manifold for throttling flow to or from the helium distribution header. Provide a pressure indicator and a relief valve on the storage cylinder manifold.

(2) Pressure. Arrange piping so that the tank cars or tube trailers can initially equalize pressure with the high-pressure storage cylinders before using compressors. Provide a vacuum relief valve and rupture disk in the suction piping to all vacuum pumps.

e. Piping Design. Design process and utility piping in accordance with the American National Standards Institute (ANSI) B31.1, Code for Pressure Piping, Power Piping, and B31.3, Code for Pressure Piping, Chemical Plant and Petroleum Refinery Piping. Prepare a stress analysis and load calculations, including a seismic evaluation.

(1) Piping. Piping for fluids with design temperatures above -20° F shall conform to the American Society for Testing and Materials (ASTM) A106, Seamless Carbon Steel Pipe for High Temperature Service. Piping for fluids with design temperatures below -20° F but above -425° F shall be types 304L or 316 stainless steel conforming to ASTM A312, Seamless and Welded Austenitic Stainless Steel Pipe. Allowable working pressures for ASTM A106 and A312 pipe are listed in Tables 1, 2, and 3. For applications requiring design pressures not covered in Tables 2 or 3, calculate the minimum pipe wall thickness as specified in ANSI B31.1, Part 2, Section 104, and select pipe schedule. Vent piping for fluids with design temperatures above -20° F shall conform with ASTM A53, Black and Hot Dipped, Zinc Coated Seamless and Welded Carbon Steel Pipe.

MIL-HDBK 1024/2

Table 1
 Allowable Working Pressures for ASTM A106, Seamless Carbon Steel Pipe

Nominal pipe size (in)	Schedule	Wall thick- ness (in)	Allowable working pressures A106			
			Grade A		Grade B	
			100° F	450° F	100° F	450° F
1/2	40	.109	2040	1770	2380	2060
3/4	40	.113	1750	1510	2040	1760
	80	.154	3110	2700	3630	3150
1	40	.133	1900	1650	2210	1920
	80	.179	3130	2710	3650	3160
	160	.250	5150	4470	6010	5210
1 1/4	40	.140	1530	1420	1910	1650
	80	.191	2700	2340	3150	2730
	160	.250	3990	3460	4650	4030
1 1/2	40	.145	1510	1310	1760	1530
	80	.200	2510	2170	2920	2530
	160	.281	4050	3510	4720	4090
2	40	.154	1330	1150	1550	1340
	80	.218	2240	1950	2620	2270
	160	.343	4140	3590	4830	4190
2 1/2	40	.203	1660	1440	1940	1680
	80	.276	2540	2200	2960	2570
	160	.375	3780	3280	4410	3820
3	40	.216	1480	1280	1730	1500
	80	.300	2300	2000	2680	2330
	160	.438	3710	3220	4330	3760
4	40	.237	1300	1130	1520	1320
	80	.337	2050	1780	2390	2070
	160	.531	3590	3110	4180	3620
5	40	.258	1170	1020	1370	1180
	80	.375	1880	1630	2190	1900
	160	.625	3470	3010	4050	3510
6	40	.280	1090	950	1270	1100
	80	.432	1860	1610	2170	1880
	160	.718	3380	2930	3950	3420
8	40	.322	990	860	1160	1000
	80	.500	1680	1460	1960	1700
	160	.906	3330	2890	3890	3370
10	40	.365	920	800	1080	940
	60	.500	1340	1160	1568	1360
	160	1.125	3370	2920	3930	3400
12	Standard	.375	800	700	940	810
	Extra strong	.500	1130	980	1310	1140
	160	1.312	3330	2890	3890	3370

MIL-HDBK 1024/2

Table 2
Allowable Working Pressures for ASTM A312, Type 304L Stainless Steel Pipe

TEMPERATURE °F.			-425 TO 300	400	500	600	650	700	750	800	850	900	950	1000	1050	1100	1150	1200	1250
MAX. STRESS			14200	13400	12500	11850	11650	11400	11250	11000	10900	10100	8400	6600	5350	4350	3400	2750	2200
NOM. PIPE SIZE	SCH. NO.	NOM. WALL	ALLOWABLE WORKING PRESSURES PSIG 304L																
			1/2	40S 80S	.109 .147	3546 4955	3346 4676	3122 4362	2959 4135	2909 4065	2847 3978	2809 3926	2747 3839	2722 3804	2522 3524	2098 2931	1648 2303	1336 1867	1114 1573
3/4	40S 80S	.113 .154	2892 4061	2729 3832	2545 3575	2413 3389	2372 3332	2321 3260	2291 3217	2240 3146	2220 3117	2057 2888	1710 2402	1344 1887	1089 1530	904 1280	737 1063	596 860	477 688
1	40S 80S	.133 .179	2704 3738	2552 3528	2381 3291	2257 3120	2219 3067	2171 3001	2142 2962	2095 2896	2076 2869	1923 2659	1600 2211	1257 1737	1019 1408	844 1176	686 972	555 786	444 628
1 1/4	40S 80S	.140 .191	2227 3109	2101 2934	1960 2737	1858 2595	1827 2551	1788 2496	1764 2463	1725 2408	1709 2387	1584 2211	1317 1839	1035 1445	839 1171	693 973	559 796	452 644	362 515
1 1/2	40S 80S	.145 .200	2003 2823	1890 2664	1763 2485	1671 2356	1643 2316	1608 2267	1587 2237	1551 2187	1537 2167	1425 2008	1185 1670	931 1312	754 1063	622 882	500 719	405 581	324 465
2	40S 80S	.154 .218	1687 2437	1592 2300	1485 2145	1408 2034	1384 1999	1355 1956	1337 1931	1307 1888	1295 1871	1200 1733	998 1441	784 1132	635 918	523 759	419 615	338 497	271 398
2 1/2	40S 80S	.203 .276	1845 2557	1741 2413	1624 2251	1540 2134	1514 2098	1481 2053	1462 2026	1429 1981	1416 1963	1312 1819	1091 1512	857 1188	695 963	572 797	459 647	371 523	297 418
3	40S 80S	.216 .300	1602 2265	1512 2138	1410 1994	1337 1890	1315 1859	1286 1819	1269 1795	1241 1755	1230 1739	1140 1611	948 1340	744 1053	603 853	496 705	397 569	321 460	257 368
3 1/2	40S 80S	.226 .318	1461 2091	1379 1974	1286 1841	1219 1745	1199 1716	1173 1679	1158 1657	1132 1620	1122 1605	1039 1487	864 1237	679 972	550 788	452 650	361 524	292 423	233 339
4	40S 80S	.237 .337	1358 1963	1282 1853	1196 1728	1133 1638	1114 1611	1090 1576	1076 1555	1052 1521	1043 1507	966 1396	803 1161	631 912	511 739	420 610	334 490	270 396	216 317
5	40S 80S	.258 .375	1191 1758	1124 1659	1048 1547	994 1467	977 1442	956 1411	943 1392	922 1361	914 1349	847 1250	704 1039	553 817	448 662	367 545	292 437	236 353	189 282
6	40S 80S	.280 .432	1082 1697	1021 1602	952 1494	903 1416	887 1393	868 1363	857 1345	838 1315	830 1303	769 1207	640 1004	503 789	407 639	334 526	265 421	214 341	171 272
8	40S 80S	.322 .500	952 1501	898 1416	838 1321	794 1253	781 1231	764 1205	754 1189	737 1163	731 1152	677 1067	563 888	442 697	358 565	293 464	232 371	188 300	150 240
10	40S 80S	.365 .500	864 1194	815 1127	760 1051	721 996	709 980	693 959	684 946	669 925	663 917	614 849	511 706	401 555	325 450	266 369	210 293	170 237	136 189

MIL-HDBK 1024/2

Table 3
 Allowable Working Pressures for ASTM A312, Type 316 Stainless Steel Pipe

TEMPERATURE °F.		-325	400	500	600	650	700	750	800	850	900	950	1000	1050	1100	1150	1200	1250	
		10																	
		300																	
MAX. STRESS		17000	16400	15200	14400	14200	13850	13600	13500	13350	13200	13100	13000	12300	10500	8350	6300	4600	
NOM. PIPE SIZE	SCH. NO.	NOM. WALL	ALLOWABLE WORKING PRESSURES PSIG																
			316																
1/4	40S	.109	4246	4096	3796	3596	3546	3459	3396	3371	3334	3296	3271	3247	3072	2689	2254	1701	1242
	80S	.147	5933	5723	5304	5025	4955	4833	4746	4711	4659	4606	4571	4537	4292	3797	3254	2455	1793
3/8	40S	.113	3462	3340	3095	2932	2892	2820	2770	2749	2719	2688	2668	2647	2505	2183	1811	1366	997
	80S	.154	4862	4690	4347	4118	4061	3961	3844	3861	3818	3775	3747	3718	3518	3091	2612	1971	1439
1	40S	.133	3238	3123	2895	2742	2704	2638	2590	2571	2542	2514	2495	2476	2342	2038	1686	1272	929
	80S	.179	4476	4318	4002	3791	3738	3646	3580	3554	3515	3475	3449	3422	3238	2839	2387	1801	1315
1 1/4	40S	.140	2666	2572	2384	2258	2227	2172	2133	2117	2093	2070	2054	2039	1929	1673	1374	1036	757
	80S	.191	3722	3591	3328	3153	3109	3033	2978	2956	2923	2890	2868	2846	2693	2350	1957	1476	1076
1 1/2	40S	.145	2398	2313	2144	2031	2003	1954	1918	1904	1883	1862	1848	1834	1735	1502	1230	928	677
	80S	.200	3380	3261	3022	2863	2823	2754	2704	2684	2654	2625	2605	2585	2446	2130	1765	1332	972
2	40S	.154	2020	1949	1806	1711	1687	1646	1616	1604	1586	1569	1557	1545	1462	1263	1029	776	567
	80S	.218	2918	2815	2609	2471	2437	2377	2334	2317	2291	2265	2248	2231	2111	1833	1511	1140	832
2 1/2	40S	.203	2209	2131	1975	1871	1845	1800	1767	1754	1735	1715	1702	1689	1598	1382	1129	852	622
	80S	.276	3061	2953	2737	2593	2557	2494	2449	2431	2404	2377	2359	2341	2215	1925	1589	1199	875
3	40S	.216	1918	1851	1715	1625	1602	1563	1535	1523	1506	1489	1478	1467	1388	1198	975	736	537
	80S	.300	2712	2617	2425	2297	2265	2210	2170	2154	2130	2106	2090	2074	1962	1702	1399	1055	770
3 1/2	40S	.226	1750	1688	1564	1482	1461	1425	1400	1389	1374	1358	1348	1338	1266	1092	886	669	488
	80S	.318	2504	2416	2239	2121	2091	2040	2003	1988	1966	1944	1929	1915	1812	1570	1287	971	709
4	40S	.237	1626	1569	1454	1378	1358	1325	1301	1291	1277	1263	1253	1244	1177	1014	822	620	453
	80S	.337	2351	2268	2102	1991	1963	1915	1880	1867	1846	1825	1811	1797	1701	1472	1204	909	663
5	40S	.258	1426	1375	1275	1207	1191	1161	1140	1132	1119	1107	1098	1090	1031	888	718	542	395
	80S	.375	2104	2030	1881	1782	1758	1714	1683	1671	1652	1634	1621	1609	1522	1316	1073	810	591
6	40S	.280	1295	1249	1158	1097	1082	1055	1036	1028	1017	1006	998	990	937	806	651	491	358
	80S	.432	2032	1960	1817	1721	1697	1656	1626	1614	1596	1578	1566	1554	1470	1270	1035	781	570
8	40S	.322	1140	1100	1019	966	952	929	912	905	895	885	878	872	825	709	571	431	314
	80S	.500	1797	1734	1607	1522	1501	1464	1438	1427	1411	1395	1385	1374	1300	1122	911	687	502
10	40S	.365	1034	998	925	876	864	842	827	821	812	803	797	791	748	642	517	390	285
	80S	.500	1430	1379	1278	1211	1194	1165	1144	1135	1123	1110	1102	1093	1034	890	720	543	397

MIL-HDBK 1024/2

(a) **Welding.** Welded piping joints and joint configurations shall comply with ANSI B31.3 and American Welding Society (AWS) Standards. Use either butt or socket welding fittings, depending on pipe size. Welding and welder qualifications shall conform to ASME Boiler and Pressure Vessel Code, Section IX, Welding and Brazing Qualifications. Radiograph all welds that will be in an inaccessible area, such as under pavement. Visually examine the remaining pipe welds.

(b) **Arrangement.** Use a minimum pipe size of 1 inch (25.1 mm), except at instrument connections, to provide mechanical strength and to allow wide spacing of pipe supports. Clean carbon steel piping by pickling. Perform a passivation treatment, producing a thin iron-phosphate coating on the inside of the pipe to ensure helium purity.

(c) **Color Code.** Color code all helium piping gray, as specified in NAVFAC P-309, Color for Naval Shore Facilities.

(2) **Hose and Expansion Joints.** Flexible, nonpermeable metal bellows material shall be used for hose and expansion joints. Provide a section of flexible hose in compressor discharge lines to absorb mechanical vibrations. Provide expansion joints in the piping to compensate for thermal expansion and contraction. Do not use rubber, nylon, plastic, polyvinyl chloride (PVC), or other materials that are highly permeable to helium.

(3) **Strainers and Coalescing Oil Filters.** Provide fine mesh screen strainers in compressor suction piping. Provide coalescing oil filters in lubricated compressor discharge piping to remove oil and particles 1 micron and larger.

(4) **Insulation.** Insulate piping for energy conservation, process control, and personnel protection. Recommended insulation materials include fiberglass, polystyrene, and cellular glass (e.g., Foamglass). Insulate process piping below -50° F. Insulate piping below 32° F when it is accessible to personnel. Provide aluminum jacketing and a pinhole-free vapor barrier on all insulated piping.

f. **Underground Pipelines.** Bury underground transfer pipelines below the frost line and avoid the water table. Coat or wrap underground pipelines with PVC or polyethylene (PE). Backfill and compact the soil to 95 percent of the maximum density.

(1) **In Corrosive Soils.** Surround underground pipelines in corrosive soils with well-slaked lime, loam, or clay.

(2) **Under Roads or Railroad Tracks.** Use culverts or steel casing to protect underground pipelines crossing under roads or railroad tracks.

MIL-HDBK 1024/2

g. Piping Test. Pressure test and certify all piping in accordance with the ASME Boiler and Pressure Vessel Code, Section VIII, Division I, and ANSI B31.3 prior to installation. Subject piping to a hydrostatic pressure test at 150 percent of the design pressure or to a pneumatic pressure test with clean, dry nitrogen gas as 125 percent of the design pressure. Pressure tests shall be conducted by experienced personnel, including an engineer responsible for safety. Clean the piping with a solvent, such as acetone, after completion of the test. Purge with dry nitrogen and cap the pipe. Purge the piping with dry nitrogen after field installation and isolate to prevent contamination.

h. Pipe Sizing.

(1) Pipe Sizing: Single Phase Flows. Size piping to ensure fluid velocities and pressure drops within the limits shown in Table 4. Select the smallest pipe size for each system that does not cause an excessive pressure drop or fluid velocity. Size piping for fluid velocity or pressure drop if specified by the repurification process. Use the Darcy equation (Equation (1)) to determine the friction pressure drop for incompressible flows. Determine the friction pressure drop for compressible flows using Equations (1), (3), (4), and (5) with the following restrictions: use inlet conditions when the friction pressure drop is less than 10 percent of the inlet pressure, and use the average of inlet and outlet conditions when the friction pressure drop is between 10 and 40 percent of the inlet pressure. Use Figure 11 to determine the friction factor, f (dimensionless). Use Figure 12 to determine the equivalent length of pipe for the friction pressure drop through the piping system valves and fittings.

EQUATION:
$$\Delta P = \frac{0.0013 f L v^2 \rho}{d} \quad (1)$$

EQUATION:
$$v = \frac{q}{A} \quad (2)$$

EQUATION:
$$v = \frac{0.00141 Q T}{P d^2} \quad (\text{gas}) \quad (3)$$

EQUATION:
$$\rho_H = \frac{0.374 P}{T} \quad (\text{helium}) \quad (4)$$

EQUATION:
$$\rho_A = \frac{2.710 P}{T} \quad (\text{air}) \quad (5)$$

MIL-HDBK 1024/2

Table 4
Line Sizing Criteria

Service	Normal Friction Drop (psi/100 ft)	Velocity (ft/sec)	
		Normal Maximum	Maximum Limit
Liquids	0.50	15	30
Gases and Vapors¹			
Less than 15 psia	0.05-0.25	200-250	50% Sonic ²
15 psig to 100 psig	0.25-0.50	150-200	50% Sonic ²
100 psig to 1,000 psig	0.50-2.00	100-150	50% Sonic ²
1,000 psig to 3,000 psig	2.00-6.00	100	50% Sonic ²
Two-Phase Flow	0.75-1.25	80	120

¹ Pressure drop is for headers or transfer lines within plant limits. Short branch lines may be sized for two or three times this friction loss.

² Sonic velocity (ft/sec) = $[gkZRT/M]^{1/2}$
 where,

- g = 32.17 (lbm-ft)/(lbf)
- k = specific heat ratio
- Z = compressibility factor
- R = 1,546 (lbf-ft)/(lb-mole °R)
- T = absolute temperature (°R)
- M = molecular weight

MIL-HDBK 1024/2

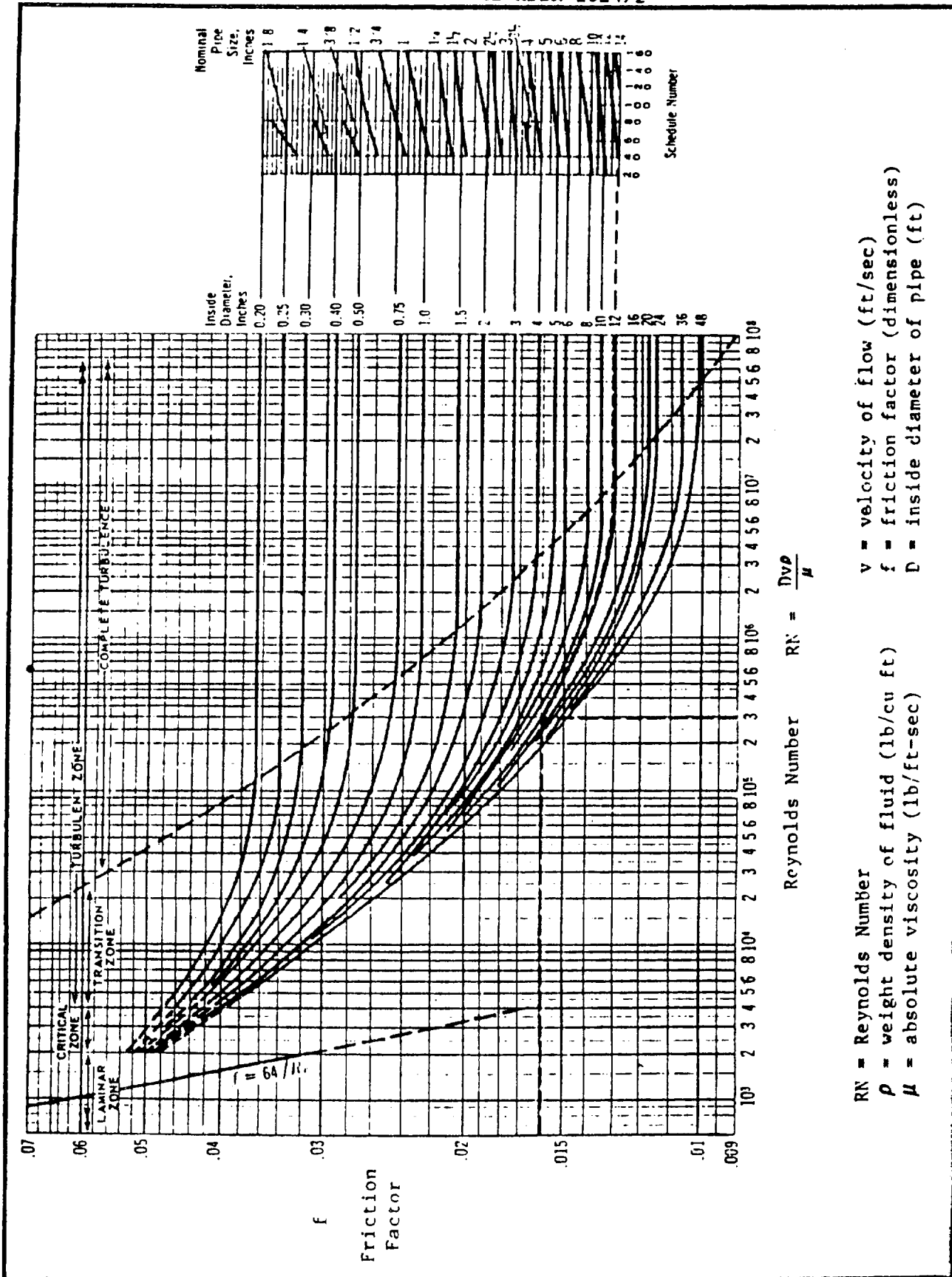

RN = Reynolds Number
 ρ = weight density of fluid (lb/cu ft)
 μ = absolute viscosity (lb/ft-sec)

v = velocity of flow (ft/sec)
 f = friction factor (dimensionless)
 D = inside diameter of pipe (ft)

$$RN = \frac{Dv\rho}{\mu}$$

FIGURE 11
 Friction Factors for Clean Steel Pipe

MIL-HDBK 1024/2

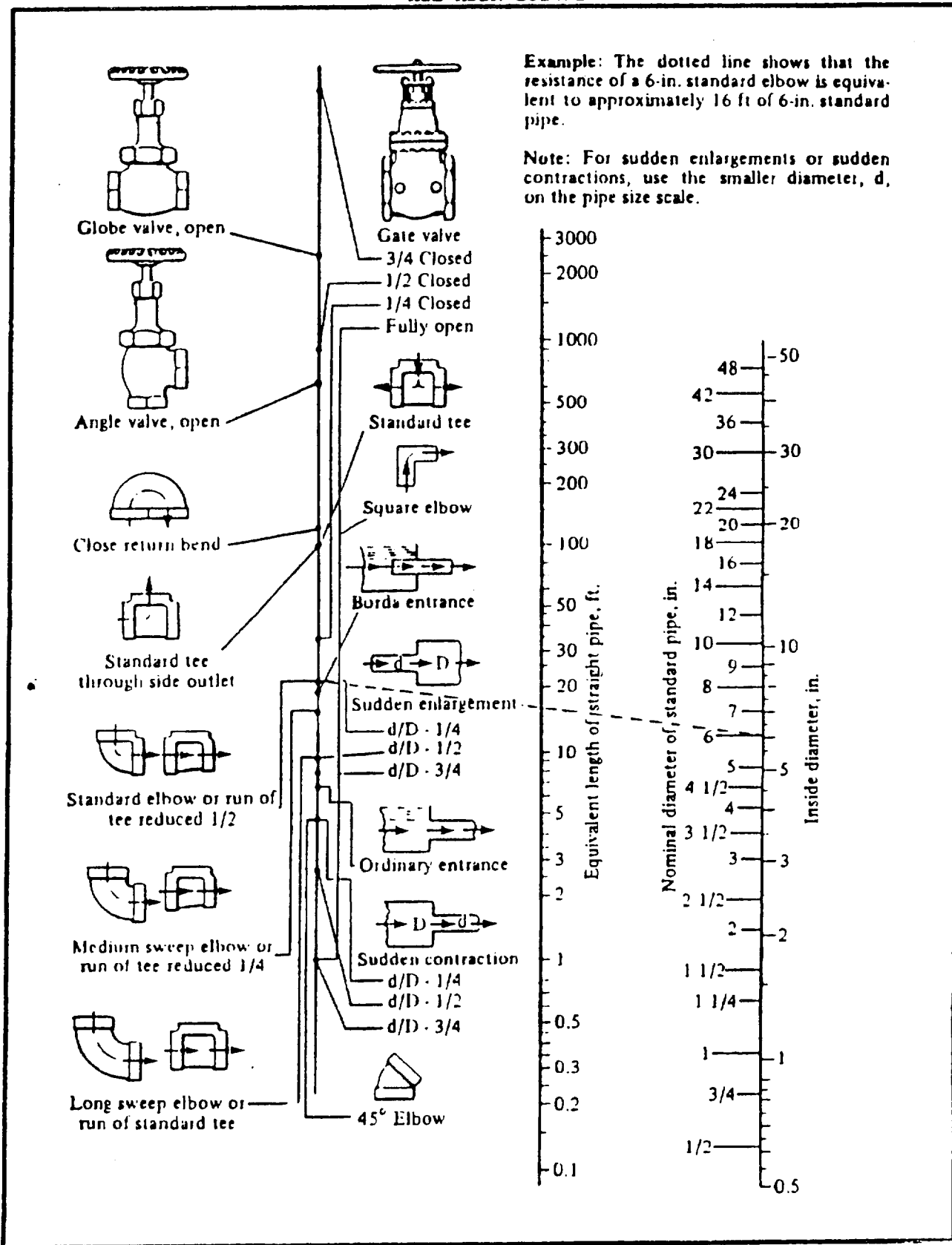

FIGURE 12
 Equivalent Length Resistance of Valves and Fittings

MIL-HDBK 1024/2

where,

- ΔP = friction pressure drop (psi)
- f = friction factor (dimensionless): see Figure 11
- L = equivalent length of piping (ft)
- v = fluid velocity (ft/sec)
- ρ = weight density of fluid (lb/cu ft)
- ρ_H = weight density of helium (lb/cu ft)
- ρ_A = weight density of air (lb/cu ft)
- d = inside diameter of pipe (in)
- A = cross-sectional area of pipe (sq ft)
- q = flow rate (cu ft/sec) at flowing conditions
- Q = flow rate (cu ft/hr) at standard conditions (70° F and 14.7 psia)
- P = absolute pressure (psia)
- T = absolute temperature (° F)

(2) Pipe Sizing: Two-Phase Flows. Two-phase gas-liquid flows have been extensively studied over the past several decades. Various approaches have been developed to correlate and predict the pressure drop due to friction in two-phase flows, each with its own restrictions and limitations. A single accurate, general correlation has not yet been developed. The most widely used correlations are empirical and represent data only for the specific flow systems studied. For initial design friction pressure drop estimates, the most widely used empirical correlation is that of Lockhart, R.W. and Martinelli, R.C., Proposed Correlation of Data for Isothermal Two-Phase, Two-Component Flow in Pipes. The accuracy of the Lockhart and Martinelli correlation has been estimated by Coats, J. and Pressburg, B.S., Chemical Engineering, CE Refresher, September 1959, and Balasubramanian, G.R., et al., Chemical Engineering, Plant Notebook, June 1980. The correlation of Martinelli, R.C. and Nelson, D.B., Prediction of Pressure Drop During Forced Circulation Boiling of Water, considering higher operating pressures, and the complex correlation of Baroczy, C.J., A Systematic Correlation for Two-Phase Pressure Drop, considering the effect of mass velocity, are also widely referenced. For other correlations and references for incorporation into the detailed design friction pressure drop estimates, see the following: Hsu, Y. and Graham, R.W., Transport Processes in Boiling and Two-Phase Systems; Handbook of Fluids in Motion; Bergles, A.E., Collier, J.G., Delhaye, J.M., Hewitt, G.F., and Mayinger, F., Two-Phase Flow and Heat Transfer in the Power and Process Industries.

(a) Criteria. Size piping according to the fluid velocities and pressure drops specified in Table 4.

(b) Flow Patterns. Two-phase gas-liquid mixtures form numerous types of flow patterns, including dispersed (mist), annular, bubble, and slug flows. Dispersed two-phase flows occur in the cryogenic adsorption and condensing by Joule-Thompson expansion repurification methods. Dispersed flow displays no acceleration or slip between phases. Both phases travel at the same velocity.

MIL-HDBK 1024/2

(c) Pressure Drop Calculation: Lockhart and Martinelli Correlation. Estimate friction pressure drop for two-phase dispersed flow in horizontal pipe for the initial design calculation using the semi-empirical correlation of Lockhart and Martinelli. Assume a diameter and calculate the single-phase pressure drop gradients, $(\Delta P/\Delta L)_l$ and $(\Delta P/\Delta L)_g$, using the Darcy equation, Equations (6) and (7). Calculate the gradient ratio factor, X , using Equation (10). Use the calculated X and Figure 13 to obtain the phase ratio factors Y_L and Y_G . Calculate the two-phase friction gradient factor, $(\Delta P/\Delta L)_{tp}$, using Equation (11) or (12). Calculate the actual pressure drop using Equation (13).

EQUATION:
$$\left(\frac{\Delta P}{\Delta L}\right)_l = \frac{0.0013 f_l v_l^2 \rho_l}{d} \quad (6)$$

EQUATION:
$$\left(\frac{\Delta P}{\Delta L}\right)_g = \frac{0.0013 f_g v_g^2 \rho_g}{d} \quad (7)$$

EQUATION:
$$v_l = \frac{q_l}{A} \quad (8)$$

EQUATION:
$$v_g = \frac{q_g}{A} \quad (9)$$

EQUATION:
$$X = \left[\frac{\left(\frac{\Delta P}{\Delta L}\right)_l}{\left(\frac{\Delta P}{\Delta L}\right)_g} \right]^{1/2} \quad (10)$$

EQUATION:
$$\left(\frac{\Delta P}{\Delta L}\right)_{tp} = Y_L \left(\frac{\Delta P}{\Delta L}\right)_l \quad (11)$$

EQUATION:
$$\left(\frac{\Delta P}{\Delta L}\right)_{tp} = Y_G \left(\frac{\Delta P}{\Delta L}\right)_g \quad (12)$$

EQUATION:
$$\Delta P = \left(\frac{\Delta P}{\Delta L}\right)_{tp} L \quad (13)$$

MIL-HDBK 1024/2

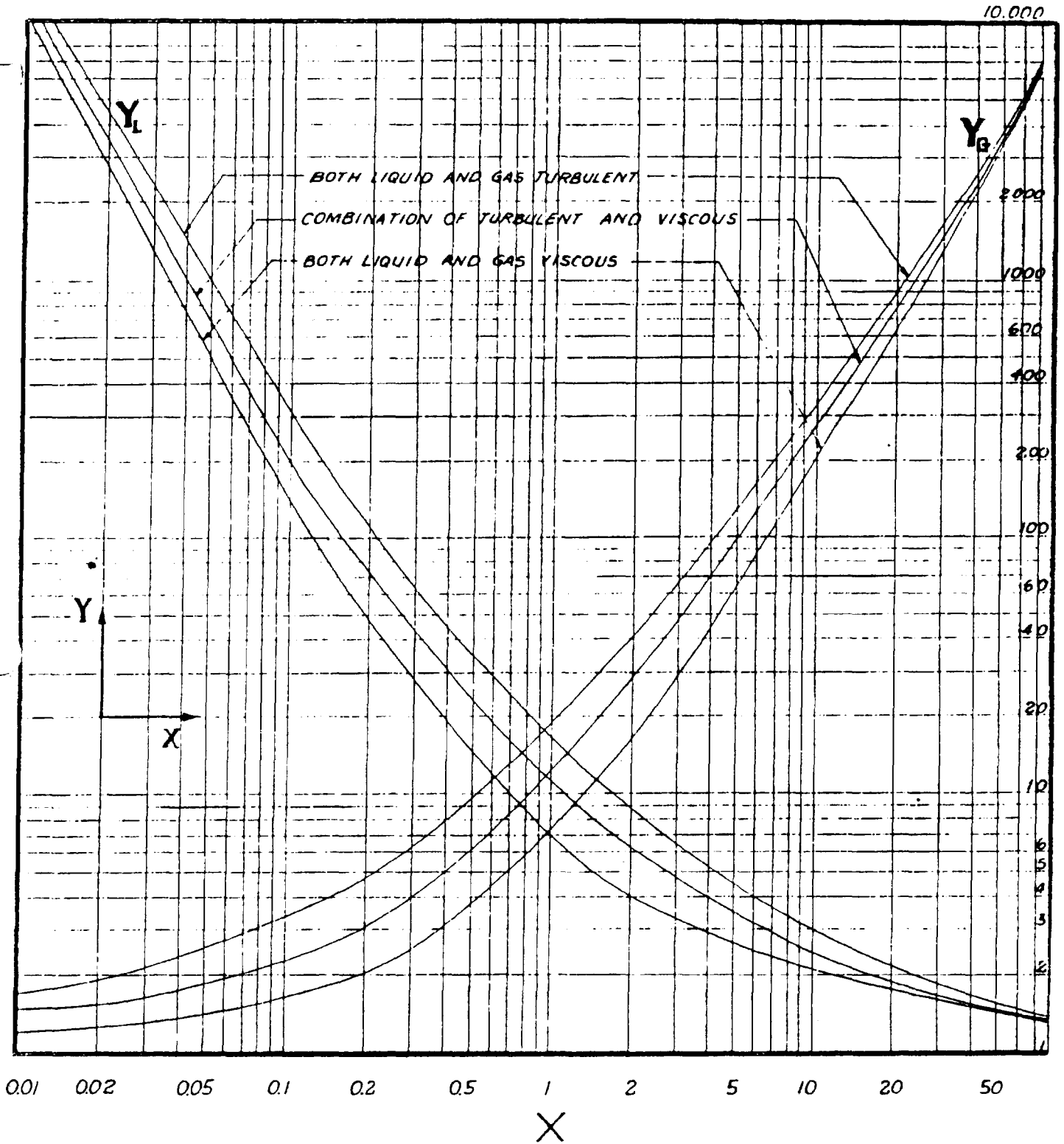

Figure 13
Two-Phase Pressure Drop Factors

MIL-HDBK 1024/2

where,

ΔP = friction pressure drop (psi)
 L = equivalent length of pipe (ft)

$\left(\frac{\Delta P}{\Delta L}\right)_{tp}$ = two-phase friction gradient factor (psi/ft)

$\left(\frac{\Delta P}{\Delta L}\right)_l$ = single-phase liquid friction gradient factor (psi/ft)

$\left(\frac{\Delta P}{\Delta L}\right)_g$ = single-phase gas friction gradient factor (psi/ft)

f_l = liquid phase friction factor (dimensionless)

f_g = gas phase friction factor (dimensionless)

V_l = liquid phase superficial velocity (ft/sec)

V_g = gas phase superficial velocity (ft/sec)

ρ_l = weight density of liquid phase (lb/cu ft)

ρ_g = weight density of gas phase (lb/cu ft)

d = inside diameter of pipe (in)

A = cross-sectional area of pipe (sq ft)

q_l = liquid phase flow rate (cu ft/sec)

q_g = gas phase flow rate (cu ft/sec)

X = gradient ratio factor (dimensionless)

Y_L = liquid phase ratio factor (dimensionless)

Y_G = gas phase ratio factor (dimensionless)

i. Valves.

(1) Helium Service Valves. Use tight shutoff valves for all helium services. Teflon, brass, and 316 stainless steel materials are recommended for use in tight shutoff valves. Do not use valves with lubricated plugs, due to the danger of contaminating the helium.

(2) Throttling Valves. Use the globe or flow control valve at the end of the cylinder fill manifold for throttling; do not use the cylinder valve for throttling.

(3) Relief Valves. Install pressure and vacuum relief valves to protect equipment and piping from pressures above or below the approved rating.

(4) Control Valve Station. Use single-seat, tight-closing, air-loaded diaphragm control valves. A typical control valve station is shown on Figure 14. The control valve station shall include: (a) control valve, (b) block valves, (c) drain and bleed valve, (d) bypass line, (e) bypass shut-off valve (globe valve). Determine block and bypass valve sizes from Table 5. For example, a 3-inch control valve in a 4-inch pipe would require 4-inch block valves and a 3-inch bypass valve.

MIL-HDBK 1024/2

j. **Control Valve Sizing.** Size control valves based on capacity and pressure drop criteria, using the valve flow coefficient (C_v) and information from the valve manufacturer. C_v is the minimum capacity sizing factor. The type of fluid (liquid, vapor, or two-phase) and the type of flow (critical or subcritical) determine the method of C_v computation.

(1) **Capacity and Pressure Drop Criteria.** Size the control valve for a capacity of 150 percent of the normal maximum flow rate. The normal maximum flow rate is the maximum flow rate considered normal during operation. Size the control valve for a pressure drop of 15-30 percent of the maximum dynamic system loss or 10 psi (70 kPa), whichever is greater. The maximum dynamic system loss is the total friction loss in the pipe, control valves, and equipment at normal maximum flow rates.

(2) **Sizing Method.** Determine or assume flow conditions in the pipe and the pressure drop across the valve. Calculate C_v from Equations (15), (19), or (22). Match the calculated C_v with the C_v values provided by the manufacturer, listed by size and type of valve. Select a valve size with a C_v equal to or slightly greater than the calculated C_v .

(3) **Flow Type.** Flow is considered subcritical when an increase in pressure drop across the valve results in an increase in flow rate. Flow is considered critical or choked when an increase in pressure drop across the valve does not result in a further increase in flow rate. Liquid flowing under critical conditions causes flashing and cavitation. In general, control valves are sized to avoid critical flow. All control valves discussed under repurification methods are in subcritical flow services.

(4) **Flow Coefficient: Liquid Service.** Use Equations (15), (16), and (17) to determine C_v for control valves in liquid service. Liquid flow is considered subcritical if Equation (14) is true.

EQUATION:
$$\Delta P < F_L^2 (\Delta P_S) \quad (14)$$

EQUATION:
$$C_v = q \left(\frac{G_0}{\Delta P} \right)^{1/2} \quad \left(\begin{array}{l} \text{subcritical} \\ \text{liquid flow} \end{array} \right) \quad (15)$$

EQUATION:
$$\Delta P_S = P_1 - P_v \quad \text{if } P_v < 0.5 P_1 \quad (16)$$

MIL-HDBK 1024/2

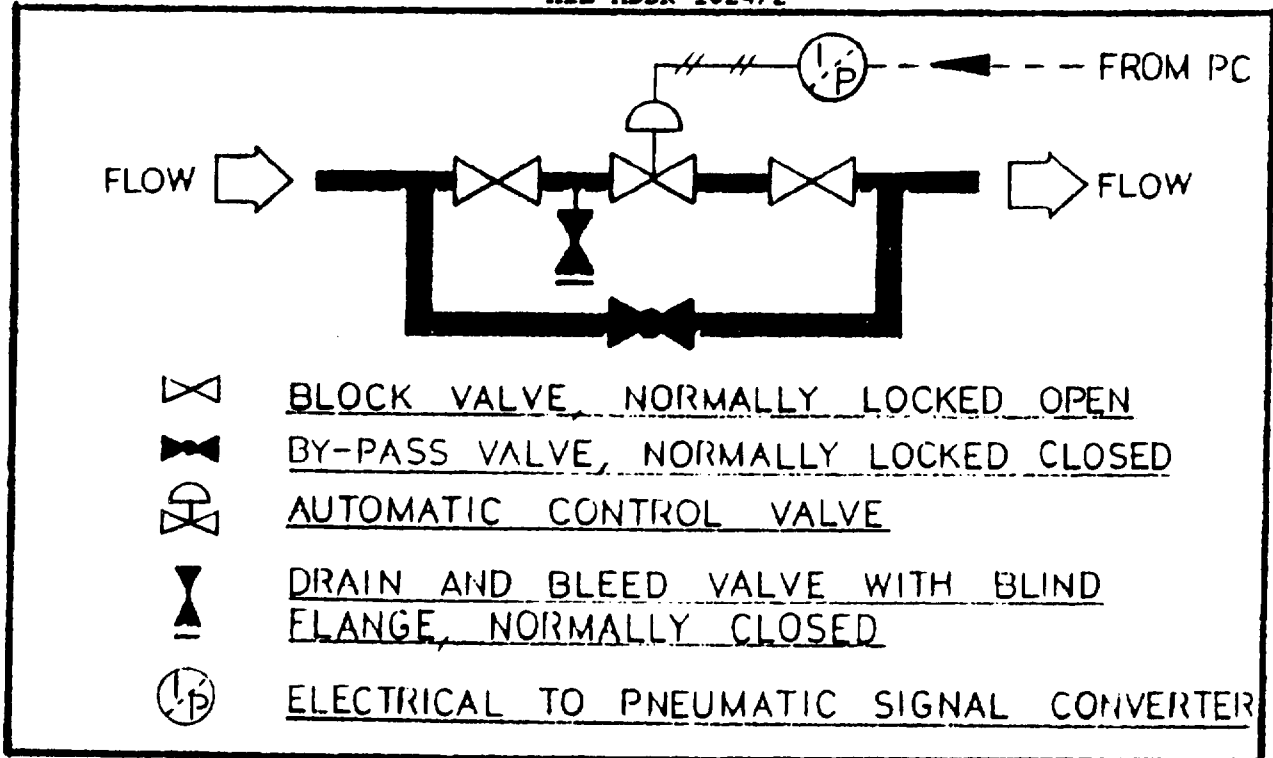

FIGURE 14
 Typical Control Valve Station

TABLE 5
 Control Valve Station: Block and Bypass Valve Sizing

Control Valve Size (inches)	Block, Bypass Valve Size	Pipe Size (inches)								
		3/4	1	1-1/2	2	3	4	6	8	10
3/4	Block	3/4	1	1-1/2	2					
	Bypass	3/4	1	1-1/2	2					
1	Block		1	1-1/2	2	2				
	Bypass		1	1-1/2	2	2				
1-1/2	Block			1-1/2	2	3	3			
	Bypass			1-1/2	2	3	3			
2	Block				2	3	3	4		
	Bypass				2	3	3	4		
3	Block					3	4	4	6	
	Bypass					3	4	4	6	
4	Block						4	6	6	8
	Bypass						4	6	6	8
6	Block							6	8	8
	Bypass							6	6	8
8	Block							8	10	10
	Bypass							8	8	10

MIL-HDBK 1024/2

EQUATION:
$$\Delta P_s = P_1 - P_v \left[0.96 - 0.28 \left(\frac{P_v}{P_c} \right)^{1/2} \right] \quad \text{if } P_v \geq 0.5 P_1 \quad (17)$$

where,

- C_v = valve flow coefficient
- F_L = critical flow factor (dimensionless), supplied by valve manufacturer
- G_L = specific gravity of liquid at flow temperature (dimensionless)
- P_1 = upstream pressure (psia)
- P_2 = downstream pressure (psia)
- P_c = critical pressure of liquid (psia)
- P_v = vapor pressure of liquid at flow temperature (psia)
- ΔP = $P_1 - P_2$ = pressure drop across valve (psi)
- ΔP_s = see Equations (16) and (17) (psi)
- q = valve maximum flow rate (gpm)

(5) Flow Coefficient: Gas and Vapor Service. Use Equation (19) to determine C_v for control valves in gas and vapor service. The gas flow is considered subcritical if Equation (18) is true.

EQUATION:
$$\Delta P < 0.2 P_1 \quad (18)$$

EQUATION:
$$C_v = \frac{Q}{963} \left[\frac{GTZ}{\Delta P(P_1 + P_2)} \right]^{1/2} \quad \left(\begin{array}{l} \text{subcritical} \\ \text{gas flow} \end{array} \right) \quad (19)$$

where,

- C_v = valve flow coefficient
- G = specific gravity of gas at 60° F (air = 1.0) (dimensionless)
- P_1 = upstream pressure (psia)
- P_2 = downstream pressure (psia)
- ΔP = $P_1 - P_2$ = pressure drop across valve (psi)
- Q = gas flow rate at 70° F and 14.696 psia (scfh)
- T = flow temperature (° R)
- Z = compressibility factor (dimensionless)

(6) Flow Coefficient: Two-Phase Flow. Two-phase flow assumes that finely divided liquid particles are dispersed in a gas moving at the same velocity. The flow is considered two-phase when Equation (20) is true. If Equation (20) indicates that insufficient vapor exists when entering the valve, the flow shall be considered flashing liquid and C_v shall be determined by Equation (15). The flow shall be considered a two-phase liquid and noncondensable gas flow entering the valve when vaporization of the liquid does not occur and when the flow velocity is sufficiently high to ensure a turbulent, well-mixed stream. Use Equation (22) to determine C_v for control valves in two-phase liquid and noncondensable gas flow service.

MIL-HDBK 1024/2

EQUATION:
$$F_L^2 (\Delta P_S) \geq \Delta P \left(\frac{W_1}{62.4 G_L} \right) \quad (20)$$

EQUATION:
$$W_1 = \frac{1}{v_1} = \frac{1}{X_g (V_{g1} - V_l) + V_l} \quad (21)$$

EQUATION:
$$C_v = \frac{M}{44.8 [\Delta P(W_1 + W_2)]^{1/2}} \quad \left(\begin{array}{l} \text{two-phase liquid and} \\ \text{noncondensable gas} \end{array} \right) \quad (22)$$

EQUATION:
$$W_2 = \frac{1}{v_2} = \frac{1}{X_g (V_{g2} - V_l) + V_l} \quad (23)$$

where,

- C_v = valve flow coefficient
- F_L = critical flow factor (dimensionless), supplied by valve manufacturer
- G_L = specific gravity of liquid at flow temperature (dimensionless)
- P_1 = upstream pressure (psia)
- P_2 = downstream pressure (psia)
- ΔP = $P_1 - P_2$ = pressure drop across valve (psi)
- ΔP_S = see Equations (16) and (17) (psi)
- M = mass flow rate of the mixture (lb/hr)
- W_1 = upstream specific weight of the mixture (lb/cu ft), see Equation (21)
- W_2 = downstream specific weight of the mixture (lb/cu ft), see Equation (23)
- v_1 = upstream specific volume of the mixture (cu ft/lb)
- v_2 = downstream specific volume of the mixture (cu ft/lb)
- V_g = specific volume of the gas (cu ft/lb)
- V_{g1} = upstream specific volume of the gas (cu ft/lb)
- V_{g2} = downstream specific volume of the gas (cu ft/lb)
- X_g = weight fraction of the gas (dimensionless)

k. Instrumentation and Control Element Specifications. Instrumentation and control element specifications shall be in accordance with ISA-S20, Specification Forms for Process Measurement and Control Instruments, Primary Elements and Control Valves. The following ISA standard forms, or equivalent, shall be used:

- | | |
|---------|---------------------------------|
| S20.2a | Annunciators |
| S20.2b | Annunciators Nameplate Schedule |
| S20.12a | Thermocouples and Thermowells |
| S20.12b | Thermocouples and Thermowells |
| S20.13a | Resistance Temperature Sensors |

MIL-HDBK 1024/2

S20.13b	Resistance Temperature Sensors
S20.20a	Differential Pressure Instruments
S20.20b	Differential Pressure Instruments
S20.21	Orifice Plates and Flanges
S20.24	Turbine Flowmeters
S20.40a	Pressure Instruments
S20.40b	Pressure Instruments
S20.41a	Pressure Gauges
S20.41b	Pressure Gauges
S20.50	Control Valves
S20.51	Pressure Control Valve Pilots and Regulators
S20.53	Pressure Relief Valves
S20.54	Rupture Discs
S20.55	Solenoid Valves

5. TRANSFER SHOP. Provide a transfer shop for filling, shipping, and periodically retesting high-pressure helium cylinders when the helium plant requires the transfer of helium by cylinders (railroad car cylinders, truck trailer cylinders, or portable cylinders). Helium plants may directly use helium from in-house storage and therefore may not require transfer shop facilities.

Cylinders offered for transportation by air, highway, railroad, or water must conform with DOT periodic retesting requirements. Provide cylinder retesting facilities in the transfer shop when onsite retesting is required. Cylinder retesting services are readily available from certified commercial vendors. A list of certified cylinder retesting vendors may be obtained from the nearest DOT office.

a. Cylinder Regulations. Fill and ship cylinders in accordance with all applicable sections of DOT regulations and specifications. Railroad car cylinders shall meet DOT specification 107A contained in 49 CFR 178. Truck trailer cylinders shall meet DOT specifications 3AX, 3AAX, or 3T as contained in 49 CFR 178. Portable cylinders (approximately 1.5 cubic feet volume) shall meet DOT specifications 3A or 3AA DOT regulations governing cylinder filling, maintenance, and periodic retesting are contained in the following:

49 CFR 173.301, General Requirements for Shipment of Compressed Gas Cylinders

49 CFR 173.302, Charging of Cylinders with Nonliquefied Compressed Gases

49 CFR 173.34, Qualifications, Maintenance, and Use of Cylinders

b. Cylinder Filling and Shipping. A BFD of the transfer shop cylinder filling and shipping is shown in Figure 15.

(1) Helium Supply. The helium for cylinder filling shall be supplied from either the helium gas storage cylinders or directly from the helium repurification plant. Run a high pressure helium line from the helium supply to the transfer shop. Boost the helium pressure with a multistage compressor if the helium supply pressure is inadequate for transfer pressure requirements. A detail of a multistage compressor, including instrumentation, is shown in Figure 3.

MIL-HDBK 1024/2

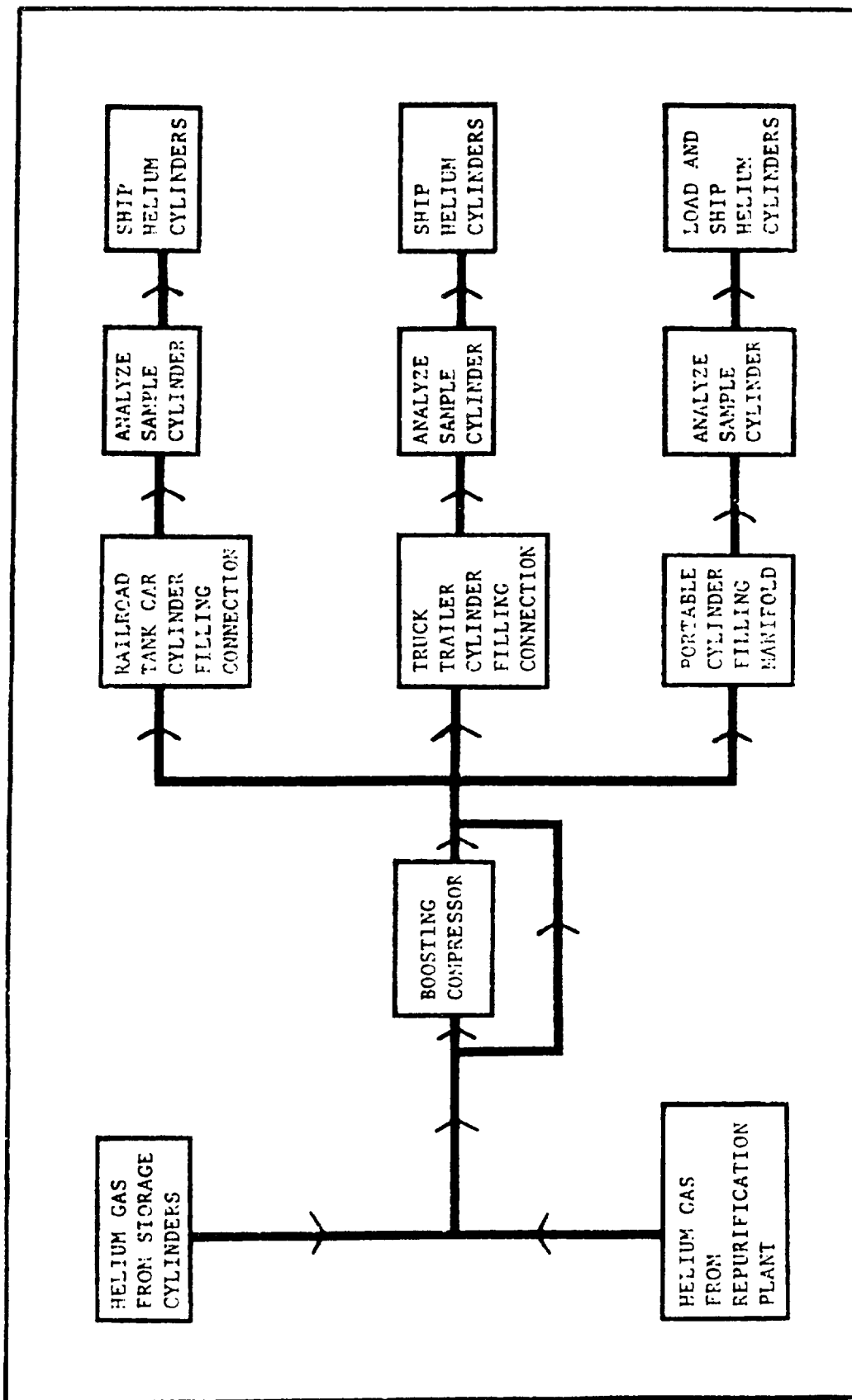

Figure 15
Block Flow Diagram: Transfer Shop Cylinder Filling and Shipping

MIL-HDBK 1024/2

(2) Railroad Tank Car Cylinder Filling Station. Provide a railroad tank car cylinder filling station when the helium plant requires helium transfer by railroad. Run a high pressure helium line from the helium supply line to the railroad car filling connection. Analyze the gas composition of one filled cylinder per car with a gas chromatograph to ensure minimum quality requirements for dew point, oxygen, hydrocarbons, or other specific contaminants. Ship the helium cylinders to the user.

(3) Truck Trailer Cylinder Filling Station. Provide a truck trailer cylinder filling station when the helium plant requires helium transfer by truck. Run a high pressure helium line from the helium supply line to the truck filling connection. Analyze the gas composition of one filled cylinder per truck with a gas chromatograph to ensure minimum quality requirements for dew point, oxygen, hydrocarbons, or other specific contaminants. Ship the helium cylinders to the user.

(4) Portable Cylinder Filling Station. Provide a portable cylinder filling station when the helium plant requires helium transfer by portable cylinders. Use a multicylinder duplex unit manifold with pressure regulators for filling the portable cylinders. Run a drop line (minimum 1-inch) from the main helium supply line to the cylinder filling manifold. Provide a pressure relief valve and indicator to protect the cylinder manifold from overpressure due to sustained cylinder filling; similar manifold instrumentation is shown on the impure helium storage cylinder manifold shown on Figure 3. Analyze the gas composition of one filled cylinder per manifold with a gas chromatograph to ensure minimum quality requirements for dew point, oxygen, hydrocarbons, or other specific contaminants. Load the portable cylinders from the transfer shop loading dock onto a truck, railroad car, or other method of transportation, and ship the helium cylinders to the user.

c. Cylinder Retesting. Periodic cylinder retesting shall include a visual examination and a hydrostatic pressure test. Retest cylinders every 5 or 10 years according to the criteria presented in 49 CFR 173.34(e). A Materials Transportation Bureau (MTB) retester's identification number is required to perform the periodic cylinder retest. A BFD of the transfer shop cylinder retesting is shown in Figure 16.

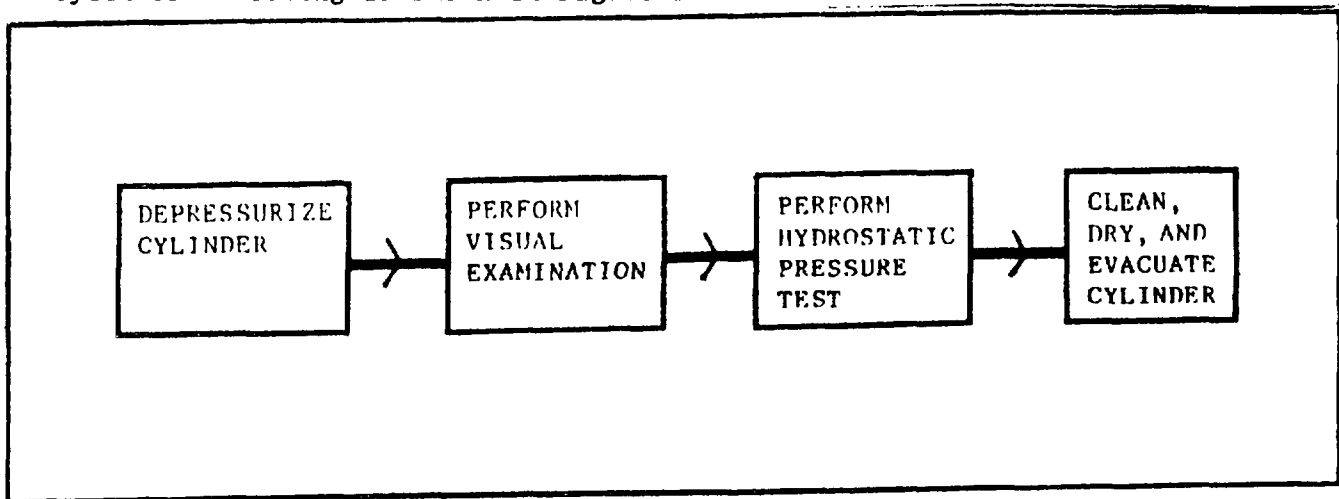

Figure 16
Block Flow Diagram: Transfer Shop Cylinder Retesting

MIL-HDBK 1024/2

(1) Internal and External Visual Inspection. Depressurize each cylinder. Perform an external and internal visual inspection of each cylinder prior to the hydrostatic pressure retest in accordance with the detailed guidelines presented in Compressed Gas Association (CGA) pamphlet C-6, Standards for Visual Inspection of Compressed Gas Cylinders. Provide a light for the internal visual inspection. Remove any internal scale and slug deposits. Seriously corroded cylinders shall be condemned.

(2) Hydrostatic Pressure Test. Retest DOT specification cylinders hydrostatically to a pressure of five-thirds of the service pressure for a minimum of 30 seconds. The pressure test shall apply interior hydrostatic pressure while the cylinder is in a water jacket or other apparatus capable of determining cylinder deformation. Provide hydrostatic pressure test apparatus. The water jacket and alternative test apparatus and procedures are detailed in CGA pamphlet C-1, Methods for Hydrostatic Testing of Compressed Gas Cylinders. Condemn cylinders that leak or that experience deformation exceeding 10 percent of the total expansion. Stamp the retested cylinder with the retest date.

(3) Clean, Dry, and Evacuate Cylinders. Provide a wash rack for cleaning and draining the cylinders in an inverted position. Dry the cylinders with a typical 5 kilowatt portable air heater having a power of 17,100 Btu per hour at 400 cfm. Evacuate the cylinder with a vacuum pump capable of providing an absolute pressure of 30 inches of water (1.1 psia) (7.5 kPa) to remove remaining moisture.

6. SAFETY. Observe the following safety guidelines:

a. General Safety for Helium Handling. Consider the following general safety guidelines for helium handling:

(1) Ventilation. Provide forced mechanical ventilation for all enclosed areas where helium is handled, stored, transferred, or repurified. Maintain a minimum concentration of oxygen in the air above 19.5 percent by volume to comply with 29 CFR 1910.94, General Industry Occupational Safety and Health Standard (OSHA). Helium gas can cause rapid asphyxiation if it displaces substantial amounts of air.

(2) Personnel Protection. Observe basic compressed gas safety practices as stated in CGA pamphlet P-1, Safe Handling of Compressed Gases in Containers. Use design layout and protective guards to protect personnel from contact with piping and valves containing cold gases. Provide insulation for cold surfaces.

(a) Cylinders. Physically secure the cylinders with a rack, a chain fastener, or a similar restraining device. A ruptured high-pressure cylinder may become a lethal projectile.

(b) Nonshatter Safety Glass. Provide nonshatter safety glass in all windows and doors in high-pressure gas handling areas.

MIL-HDBK 1024/2

(c) **Specific Job Operations.** Specific job operations shall dictate the appropriate protective clothing and equipment (e.g., splash goggles, face shield, etc.) to be worn by personnel.

(d) **Safety Pressure Relief Valves.** Equip cylinders with safety pressure relief devices in accordance with 49 CFR 173.34 and CGA pamphlet S-1.1, Pressure Relief Device Standards, Part 1 - Cylinders for Compressed Gases or ASME Boiler and Pressure Vessel Code, Section VIII, Division I.

(3) **Storage and Handling.** Observe storage and handling procedures as outlined in NAVSUPINST 4440.128B, Compressed Gas and Cylinder-Type Storage, Handling, and Quality Surveillance, Sections 5.1 and 5.2.

b. Occupational Safety and Health Administration. Comply with applicable provisions of the Occupational Safety and Health Administration (OSHA) 29 CFR 1910.

MIL-HDBK 1024/2

this page left blank intentionally

MIL-HDBK 1024/2

Section 3. RELATED FACILITIES

1. **ARCHITECTURAL REQUIREMENTS.** Architectural requirements for related facilities are in accordance with the Uniform Building Code (UBC) and NAVFAC DM-1 Series, Architecture. Provide an auxiliary building adjacent to the plant to house a workshop, office, toilet, and locker room. Additional architectural requirements are as follows:

a. Receiving and Storage Facilities. Provide a building or canopy to shelter personnel, compressors, and storage cylinders as required by the severity of local weather conditions. Provide a receiving and loading dock at truck or railroad car height where storage cylinders, liquid helium containers, or suppliers are received or stored.

b. Transfer Shop. Provide a transfer shop building when a transfer shop is required for processing high-pressure storage cylinders. The transfer shop floor and loading dock shall be at truck or railroad car loading height.

c. Repurification Plant. Provide an industrial shop building to enclose the repurification plant equipment. Determine building enclosure size by preparing a detailed plot plan and plant layout. Provide aisle space for making operating charges and for inspecting, cleaning, and servicing equipment. Provide platforms and ladders for access to elevated control valves, instrumentation, and cleanout doors.

2. **STRUCTURAL REQUIREMENTS.** Design structure and foundation loads according to NAVFAC DM-2.02, Loads. Comply with the structural requirements in NAVFAC P-355, Seismic Design for Buildings. Compressor foundation, piping supports, and hoist and crane requirements are as follows:

a. Compressor Foundations. Size foundations in accordance with the compressor manufacturer's equipment drawings and recommendations. Size foundations to minimize compressor noise and vibration in accordance with NAVFAC DM-3.10, Noise and Vibration Control for Mechanical Equipment. Insulate large compressors from the building structure and piping to dampen vibration and sound.

b. Piping Supports. Design piping support foundations in accordance with Manufacturers Standardization Society specifications SP 58, Pipe Hangers and Supports - Materials, Design and Manufacture, and SP 69, Pipe Hangers and Supports - Selection and Application.

c. Hoists and Cranes. Provide hoists and cranes over large compressors and columns in the purification plant. (Hoists lift, while cranes both lift and move.) Rated lifting capacity shall be 125 percent of the gross weight of the heaviest item serviced. Either electrical or pneumatic hoists may be used.

3. **MECHANICAL REQUIREMENTS.** Provide plumbing, ventilation, and heating as follows:

a. Plumbing. Provide water supply and drains for hygiene and industrial safety (e.g., toilet, urinal, shower, emergency shower, etc.) according to the Uniform Plumbing Code (UPC) and NAVFAC DM-3.01, Plumbing Systems.

MIL-HDBK 1024/2

b. Ventilating and Heating. Provide ventilating and heating according to NAVFAC DM-3.03 and the UBC. Provide forced mechanical ventilation for all enclosed areas where helium is handled, stored, transferred, or repurified. Maintain a minimum concentration of oxygen in the air above 19.5 percent by volume to comply with 29 CFR 1910.94. An energy management system is recommended in NAVFAC DM-4.09, Energy Monitoring and Control Systems, to effect energy and manpower savings.

4. ELECTRICAL REQUIREMENTS. Design and install electrical systems in accordance with the National Electric Code and NAVFAC DM-4.04, Electrical Utilization Systems. Design lighting system and lighting intensities according to Department of Defense 4270.1-M, Construction Criteria Manual, and the Illuminating Engineering Society (IES) Lighting Handbook. The main electric feeder, transformers, circuit breakers, and disconnect devices shall be housed indoors for equipment protection. Provide emergency power supply systems (e.g., diesel generator, gasoline generator, or battery pack) in accordance with NAVFAC DM-4.04 and Institute of Electrical and Electronic Engineers RP-446, Recommended Practice for Emergency and Standby Power Systems. Provide an individual emergency lighting and alarm system. All interconnect wiring shall conform to Instrument Society of America RP-60.8, Electrical Guide for Control Centers. All electrical and instrumentation enclosures shall conform to the National Electrical Manufacturers Association (NEMA) STD-ICS-6, Enclosures for Industrial Controls and Systems, Type 4 rating. Design and install electrical systems in accordance with NAVFAC P-355.

MIL-HDBK 1024/2

REFERENCES

American National Standards Institute (ANSI), 1430 Broadway, New York, NY 10018:

- B31.1 Code for Pressure Piping, Power Piping
- B31.3 Code for Pressure Piping, Chemical Plant and Petroleum Refinery Piping

American Society for Testing and Materials (ASTM), 1916 Race Street, Philadelphia, PA 19103:

- ASTM A53 Black and Hot Dipped, Zinc Coated Seamless and Welded Carbon Steel Pipe
- ASTM A106 Seamless Carbon Steel Pipe for High Temperature Service
- ASTM A312 Seamless and Welded Austenitic Stainless Steel Pipe

A Systematic Correlation for Two-Phase Pressure Drop, Baroczy, C.J., Chemical Engineering Progress Series 64, 62: pp. 232-249, 1966 McGraw-Hill Publishing Company, 1221 Avenue of the Americas, New York, NY 10020.

Boiler and Pressure Vessel Code, Section VIII, Division I, Rules for Construction of Pressure Vessels, and Section IX, Welding and Brazing Qualifications, American Society of Mechanical Engineers (ASME), United Engineering Center, 345 East 47th Street, New York, NY 10017.

Chemical Engineering, CE Refresher, Coats, J. and Pressburg, B.S., September 1959, pp. 153-156 McGraw-Hill Publishing Company, 1221 Avenue of the Americas, New York, NY 10020.

Chemical Engineering, Plant Notebook, Balasubramanian, G.R., et al, pp. 101-102, McGraw-Hill Publishing Company, 1221 Avenue of the Americas, New York, NY 10020, June 1980.

Code of Federal Regulations (CFR), U.S. Government Printing Office, Washington, DC 20402:

- 29 CFR 1910 General Industry Occupational Safety and Health Standard (OSHA)
- 30 CFR 601, 602 Mineral Resources
- 49 CFR 173 Transportation - Shippers - General Requirements for Shipments and Packagings
- 49 CFR 178 Transportation - Shipping Container Specifications

MIL-HDBK 1024/2

Compressed Gas Association (CGA), Inc., 1235 Jefferson Davis Highway,
Arlington, VA 22202:

- C-1 Methods for Hydrostatic Testing of Compressed Gas
Cylinders
- C-6 Standards for Visual Inspection of Compressed Gas
Cylinders
- P-1 Safe Handling of Compressed Gases in Containers
- S-1.1 Pressure Relief Device Standards, Part 1 - Cylinders
for Compressed Gases

Construction Criteria Manual, DOD 4270.1-M, Department of Defense
Publications, Superintendent of Documents, U.S. Government Printing Office,
Washington, DC 20402.

Handbook of Fluids in Motion, Ann Arbor Science Publishers, Ann Arbor,
MI 48106, 1983.

Instrument Society of America (ISA), 67 Alexander Drive, Research Triangle
Park, NC 27709:

- S5.1 Instrumentation Symbols and Identification
- S20 Specification Forms for Process Measurement and
Control Instruments, Primary Elements and Control
Valves
- RP-60.8 Electrical Guide for Control Centers, Recommended
Practice

International Conference of Building Officials (ICBO), 5360 South Workman Mill
Road, Whittier, CA 90601:

Uniform Building Code (UBC)

Uniform Plumbing Code (UPC)

Lighting Handbook, Illuminating Engineering Society (IES), 345 East 47th
Street, New York, NY 10017.

Manual For Railway Engineering, American Railway Engineering Association
(AREA), 50 F Street, NW., Washington, DC 20001

Manufacturers Standardization Society (MSS) of the Valve and Fitting Industry,
5203 Leesburg Pike, Suite 502, Falls Church, VA 22041:

- SP 58 Pipe Hangers and Supports - Materials, Design and
Manufacture
- SP 69 Pipe Hangers and Supports - Selection and Application

MIL-HDBK 1024/2

National Electrical Manufacturers Association (NEMA), 2101 "L" Street, N.W.,
Washington, DC 20037:

STD 250 Enclosures for Electronic Equipment
STD-ICS-6 Enclosures for Industrial Controls and Systems

Naval Facilities Engineering Command (NAVFACENGCOM) Design Manuals,
P-Publications, Military Handbooks, and Naval Supply Instructions
(NAVSUPINST). Copies may be obtained from the Naval Publications and Forms
Center, 5801 Tabor Avenue, Philadelphia, PA 19120.

DM-1 Series Architecture
DM-2.02 Loads
DM-3.01 Plumbing Systems
DM-3.03 Heating, Ventilating, Air Conditioning, and
Dehumidifying Systems
DM-3.05 Compressed Air and Vacuum Systems
DM-3.10 Noise and Vibration Control for Mechanical Equipment
DM-4.04 Electrical Utilization Systems
DM-4.09 Energy Monitoring and Control Systems
DM-5.06 Civil Engineering Trackage
DM-6 Series Engineering and Design Criteria Preparation
MIL-HDBK-1008 Fire Protection for Facilities Engineering, Design
and Construction
NAVSUPINST Compressed Gas and Cylinder-Type Storage, Handling,
4440.128B and Quality Surveillance
P-309 Color for Naval Shore Facilities
P-355 Seismic Design for Buildings

Prediction of Pressure Drop During Forced Circulation Boiling of Water,
Martinelli, R.C. and Nelson, D.B., Transactions of the ASME, Vol. 70: p. 695,
1948, 345 East 47th Street, New York, NY 10017.

Proposed Correlation of Data for Isothermal Two-Phase, Two-Component Flow in
Pipes, Lockhart, R.W. and Martinelli, R.C., Chemical Engineering Progress,
Vol. 45, pp. 39-48, January 1949, McGraw-Hill Publishing Company, 1221 Avenue
of the Americas, New York, NY 10020.

MIL-HDBK 1024/2

Recommended Practice for Emergency and Standby Power Systems, RP-446.
Institute of Electrical and Electronic Engineers (IEEE), 345 East 47th Street,
New York, NY 10017.

Transport Processes in Boiling and Two-Phase Systems. Hsu, Y. and Graham,
R.W., McGraw-Hill Publishing Company, 1221 Avenue of the Americas, New York,
NY, 10020, 1976.

Two-Phase Flow and Heat Transfer in the Power and Process Industries.
Bergles, A.E., Collier, J.G., Delhays, J.M., Hewitt, G.F., and Mayinger, F.,
McGraw-Hill Publishing Company, 1221 Avenue of the Americas, New York, NY,
10020, 1981.

Two-Phase Flow in Pipelines and Heat Exchangers. Chisholm, D., George Goodwin
Publishers, New York, NY, 1983.

CUSTODIAN:

NAVY - YD

PREPARING ACTIVITY
NAVY - YD

PROJECT NO. FACR-0179

INSTRUCTIONS: In a continuing effort to make our standardization documents better, the DoD provides this form for use in submitting comments and suggestions for improvements. All users of military standardization documents are invited to provide suggestions. This form may be detached, folded along the lines indicated, taped along the loose edge (*DO NOT STAPLE*), and mailed. In block 5, be as specific as possible about particular problem areas such as wording which required interpretation, was too rigid, restrictive, loose, ambiguous, or was incompatible, and give proposed wording changes which would alleviate the problems. Enter in block 6 any remarks not related to a specific paragraph of the document. If block 7 is filled out, an acknowledgement will be mailed to you within 30 days to let you know that your comments were received and are being considered.

NOTE: This form may not be used to request copies of documents, nor to request waivers, deviations, or clarification of specification requirements on current contracts. Comments submitted on this form do not constitute or imply authorization to waive any portion of the referenced document(s) or to amend contractual requirements.

(Fold along this line)

(Fold along this line)

DEPARTMENT OF THE NAVY
NAVAL FACILITIES ENGINEERING
COMMAND
200 Stovall Street
Alexandria, VA 22332-2300



NO POSTAGE
NECESSARY
IF MAILED
IN THE
UNITED STATES

OFFICIAL BUSINESS
PENALTY FOR PRIVATE USE \$300

BUSINESS REPLY MAIL
FIRST CLASS PERMIT NO 12303 WASHINGTON D C
POSTAGE WILL BE PAID BY THE DEPARTMENT OF THE NAVY

COMMANDER
Western Division
Naval Facilities Engineering Command
Code 406
P.O. Box 727
San Bruno, CA 94066



STANDARDIZATION DOCUMENT IMPROVEMENT PROPOSAL

(See Instructions - Reverse Side)

1. DOCUMENT NUMBER
 MIL-HDBK 1024/2

2. DOCUMENT TITLE
 Helium Plants and Storage

3a. NAME OF SUBMITTING ORGANIZATION

4. TYPE OF ORGANIZATION (Mark one)

- VENDOR EFD/PWO
 USER AE
 MANUFACTURER DICC/ROICC
 OTHER (Specify): _____

b. ADDRESS (Street, City, State, ZIP Code)

5. PROBLEM AREAS

a. Paragraph Number and Wording:

b. Recommended Wording:

c. Reason/Rationale for Recommendation:

6. REMARKS

7a. NAME OF SUBMITTER (Last, First, MI) - Optional:

7b. WORK TELEPHONE NUMBER (Include Area Code) - Optional:

8. MAILING ADDRESS (Street, City, State, ZIP Code) - Optional:

9. DATE OF SUBMISSION (YYMMDD):

(TO DETACH THIS FORM, CUT ALONG THIS LINE)