

MIL-HDBK-731

1 AUGUST 1984

MILITARY STANDARDIZATION HANDBOOK

NONDESTRUCTIVE TESTING METHODS OF

COMPOSITE MATERIALS - THERMOGRAPHY



AREA NDTI

No Deliverable Data Required by This Document

DEPARTMENT OF DEFENSE
WASHINGTON D.C., 20301

MIL-HDBK-731

Military Handbook for Nondestructive Testing Methods of Composite Materials - Thermography.

1. This standardization handbook was developed by the Department of Defense with the assistance of the Army Materials and Mechanics Research Center and Drs. Henneke and Reifsnider of Virginia Polytechnic Institute, Blacksburg, Virginia in accordance with established procedure.

2. It is the intent to review this handbook periodically to insure its completeness and currency. Users of this document are encouraged to report any errors discovered and any recommendations for changes or inclusions to Army Materials and Mechanics Research Center, ATTN: DRXMR-SMS, Arsenal St., Watertown, MA 02172-2719.

FOREWORD

1. This handbook will eventually become a chapter in a larger volume which will probably include the following chapters:

- Part I: Overview of Characterization Techniques for Composite Reliability
- Part II: Liquid Chromatography, A State-of-The-Art-Review
- Part III: Infrared and Raman Spectroscopy, A State-of-The-Art-Review
- Part IV: Radiography, A State-of-The-Art-Review
- Part V: Ultrasonics, A State-of-The-Art-Review
- Part VI: Acoustic Emission, A State-of-The-Art-Review
- Part VII: Thermography, A State-of-The-Art-Review
- Part VIII: Annotated Bibliography
- Part IX: Applications to the Manufacture of Composite Main Rotorblade.

2. Each chapter will be coordinated separately as the amount of materials to review at one time is large. After acceptance of the individual chapters as smaller handbooks, they will be incorporated into a single volume.

3. It is intended that this volume serve as a reference in which answers may be found to the more general questions concerning the technical aspects and applications of Thermography.

TABLE OF CONTENTS

<u>SECTION</u>		<u>PAGE</u>
1.	Scope	1
1.1	General	1
2.0	Background	1
2.1	Active and Passive Techniques	2
2.1.1	Contact and Noncontact Methods - General	2
3.0	Temperature Measurement for Thermography	3
3.1	Contact Methods	3
3.1.1	Coatings - Application	3
3.1.2	Temperature Sensitive Paints	4
3.1.3	Thermal Phosphor Type	4
3.1.4	Thermally Sensitive Papers	4
3.1.5	Liquid Crystals	5
3.1.6	Other Contact Methods	6
3.2	Noncontact Methods	6
3.2.1	Surface Thermal Patterns	7
3.2.2	Infrared Detections	7
3.2.3	Photon - Effect Devices	8
3.2.4	Application of Detectors	8
4.0	Application and Thermographic Nondestructive Testing	9
4.1	General	9
4.2	Procedures	9
4.2.1	Basic Principles of Operation	9
4.2.2	Heat Emission Patterns	10
4.2.3	Active or Passive Heat Emitter	10
4.2.3.1	Heat Introduction by Passive Thermography	11
4.2.3.2	Heat Introduction by Radiation and Convection	11
4.2.4	Development of Heat Emission Patterns	12
4.2.4.1	Passive Methods	13
4.2.4.2	Hysteresis Energy Heat Patterns	13
4.2.5	Generation of Heat Patterns	14
4.2.5.1	Active Heat Generation Procedure	15
4.2.5.2	Vibrothermography	15
4.2.5.3	Variations	15
5.0	Equipment	16
5.1	General	16
5.2	Thermal Energy Source	16
5.3	Recording and Interpretation of Images	16
6.0	Parameter Selection	17
6.1	Conductivity of Materials	17
6.1.1	Effect of Differential Heating	17
6.1.2	Thermal Image	18
6.1.3	Surface Reflectivity	18
6.1.4	Emissivity of the Surface	19
6.1.5	Damping Characteristics of Materials	19

TABLE OF CONTENTS (CONTINUED)

<u>SECTION</u>		<u>PAGE</u>
7.0	Applications	19
7.1	Principles	20
7.1.1	History	20
7.2	Techniques	20
7.3	Rapid Observation of Surfaces	21
8.0	Precautions	21
8.1	General	21
	References	22-24
	Figures One thru Seven	25-31

List of Figures

- Figure 1 The Electromagnetic Spectrum.
- Figure 2 Schematic diagram of a basic thermographic NDE System
- Figure 3 Examples of arrangements for introducing heat into a specimen by conduction.
- Figure 4 Examples of arrangements for introducing heat into a specimen by radiation and convection.
- Figure 5 Examples of heat generation by active techniques.
- Figure 6 Region size dimension effect on relaxation frequency.
- Figure 7 Percent difference between successive points on the temperature distribution at a source for a change of 0.1 in r/r_1 .

1. SCOPE

1.1 General This is the first volume of a nine volume series on nondestructive testing of composite materials. Each volume is designed to provide an overview of the general method. This volume contains an overview of techniques available for the application of thermographic nondestructive testing and evaluation techniques. General information on contact and noncontact methods of temperature measurement are discussed as these pertain directly to thermography. Special emphasis is placed on noncontact, infrared methods as these can be used for real-time observations. Practical information on the procedures which have proven useful for application of thermography to composites is discussed in some detail. In addition, present equipment which is available commercially for such tests and important test parameters which must be selected for proper observations and interpretations are discussed.

2.0 Background. Thermography is the general term given to the technique whereby contours of equal temperature-isotherms are mapped over a surface. As a technique for nondestructive testing evaluation, the applications of thermography is based upon the assumption that defects, nonhomogeneities, or other undesirable conditions of the test object will evidence themselves as local hot or cold spots in the isothermal mapping. To apply this technique one must, first, excite a thermal pattern in the test object to be studied; second, measure the areal temperature distribution on the surface of the examined test object; and, third, interpret the results according to well-established and understood physical principles.

MIL-HDBK-731

2.1 Active and Passive Techniques. For convenience, thermographic NDT techniques may be categorized as active or passive (Ref. 1) when referring to the means by which heat is produced "actively" in the specimen by transformation processes which occur while the test object is being subjected to normal operating, testing, or loading conditions. For example, an electrical component may overheat due to some abnormality when electrical current passes through it, or a structural material might develop hot spots under mechanical loading in regions where damage is occurring. On the other hand, passive methods refer to those for which the test object is treated as a path for heat from external heat source to some external heat sink. In this case, local nonhomogeneities or flaws will cause local differences in thermal conductivities which will evidence themselves in the thermal mapping. These categorizations will be dealt with in more detail in section 7.0 on the application to composites.

2.1.1 Contact and Noncontact Methods - General. The means by which the temperatures are measured can also be conveniently categorized, in this case, as contact or noncontact methods (Ref. 2). Contact methods of temperature measurement very obviously refer to those by which a physical object is brought into contact with the surface of the test specimen to determine the temperature of the latter. Noncontact methods are those which rely upon infrared radiation to determine the temperature of the radiating source. Both types will be discussed in section 3.0 on Thermographic NDT.

3.0 Temperature Measurement for Thermography.

3.1 Contact Methods. As noted earlier, the second step in applying thermographic NDT is to measure the surface temperature of the object to be examined. (The first step, exciting the thermal pattern, will be discussed in section 3.2, noncontact methods.) Perhaps the oldest and least expensive methods for doing this fall under the category of contact methods. Such methods require that actual contact be made between the surface of the examined object and the measuring device. There are a large variety of possible techniques for making contact surface temperature measurements, most of which rely upon some type of chemical reaction in an applied coating. Thermal coatings include paints, phosphors, papers, liquid crystals, and a number of other special temperature sensitive compounds. These methods have the distinct advantages of being relatively easy to apply and requiring a low initial investment, particularly if only a small area of material is to be examined. On the other hand, these methods have the disadvantages of generally yielding only a qualitative indication of temperature and of affecting, themselves, the distribution of surface temperature. There are, however, some contact coatings such as liquid crystals, which can be calibrated for temperature measurement. A major disadvantage, common to all of the contact methods, is that one must know, apriori, the approximate value of the temperature that he wishes to measure.

3.1.1 Coatings - Application. To apply a contact thermographic method, a temperature-sensitive coating must be placed upon the surface of the examined test object. A change in temperature is evidenced by a change in color or appearance of the coating due to a temperature-sensitive chemical or physical change. This change may be either reversible or permanent, depending upon the type of coating used. As mentioned in the previous paragraph, there are several types of coatings that have been used for thermographic NDT. Additional details may be found in the survey presented in Ref. 2, but some of the highlights of their use are described in sections 3.1.2, 3.1.3, 3.1.4, 3.1.5, and 3.1.6.

3.1.2 Temperature Sensitive Paints. Temperature sensitive paints have been developed for use between 40° to 1600°C . These paints undergo a color change at a temperature which, under optimum conditions, can be calibrated to within $\pm 5^{\circ}\text{C}$. Some paints exist which will progress through several different color transitions. Most often the color transitions are observable under ordinary light, but certain paints exist which may require the use of ultraviolet.

3.1.3 Thermal Phosphor Type. Another coating, which normally requires ultraviolet light for its use, is the thermal phosphor type. These phosphors, as with many such compounds, emit visible light when excited by ultraviolet radiation. For thermal phosphor, the intensity of the emitted visible light varies inversely to its temperature. The rate of decrease of light intensity with temperature is very rapid at a critical temperature, as much as $25\%/^{\circ}\text{C}$ within a very limited temperature range around the critical point. Various phosphors exist for use between room temperature and 400°C . There are several ways in which a phosphor may be applied to a surface: as a paint, a stripable coating, in a tape, or as a powder.

3.1.4 Thermally Sensitive Papers. At least three different types of thermally sensitive papers exist for thermographic NDT: organic, plastic and infrared copy papers. Organic papers are coated with a meltable organic substance. Upon reaching the melting temperature, the organic substance melts and is absorbed by the paper, turning its color from white to black. Plastic coating papers are constructed with a plastic coating containing a large density of air bubbles. These bubbles diffuse incident light giving the paper a pale color. Upon reaching the critical temperature of the paper, the plastic melts, releasing the bubbles and revealing the black color of the paper underneath. The infrared copy papers contain dye precursors which react to produce a color when melted.

3.1.5 Liquid Crystals. Liquid crystals refer to a special class of materials which at certain temperatures possess the properties of both a liquid and a crystal. These materials will flow as a viscous liquid while retaining the short range molecular structure of a crystalline solid. One form of liquid crystals, the so-called cholesteric, are dichroic. When unpolarized light is incident upon a dichroic material, it is decomposed into two components, one of which is circularly polarized clockwise while the other is circularly polarized counterclockwise. One of these components is transmitted and the other is reflected. The reflected component produces a color when the material is illuminated by white light. As cholesteric liquid crystals are heated, the distances between molecular layers increases. This distance governs the wavelength of the reflected light. Eventually the liquid crystal melts, and with further increase in temperature, becomes more and more disordered until eventually it achieves the state of an isotropic liquid. One can select liquid crystals from a wide variety of possibilities such that the liquid crystal appears colorless at low temperatures, changes through a succession of colors as it melts and approaches isotropy, and again becomes colorless when the material is totally isotropic. It is possible to obtain many different liquid crystal compounds which exhibit color changes at any temperature from -20° to 250°C . The various compounds have varying color-change temperature ranges from 10 to 30°C . The response time is relatively fast, 0.1 to 0.2 sec. The sensitivity for the detection of flaws by liquid crystals can be quite good. Depending upon the thermal conductivity and the proximity of the flaw to the surface, flaw sizes as small as $1/8$ " square have been detected.

3.1.6 Other Contact Methods. Several other temperature-sensitive compounds have found some application in thermographic NDT. Thermochromic order-disorder compounds change color with temperature without breaking chemical bonds and hence are reusable. Variable surface-tension compounds have been developed with temperature-sensitive surface tension (Ref. 2). When sprayed upon a surface, these compounds are repelled from warmer areas and coalesce in the cool areas. Hence, these compounds are more sensitive to temperature differences than they are to the absolute value of the temperature. Finally, frost testing has been applied in situations where one wished to find gross flaws or disbonds. To apply this method, one chills the surface of the examined object below the frost point so that a frosted surface is obtained. Differences in heat conductivities in the test object will then evidence themselves by the patterns formed as the frost melt.

3.2 Noncontact Methods. Noncontact methods for temperature measurement are based upon the phenomenon of infrared radiation. Infrared radiation is a portion of the electromagnetic spectrum, invisible to the human eye, with frequencies below that of the red portion of the visible spectrum (Figure 1). Early researchers found that this "infrared" light caused higher temperature readings on thermometers than did visible light. Later workers found that, as a basic law of nature, all matter at temperatures greater than absolute zero spontaneously emits infrared, or thermal, radiation. The radiation is a result of the thermal agitation, or temperature, of the basic components of which all matter is composed: molecules, atoms and subatomic particles. The frequency range covered by infrared radiation is a result of the various energies possessed by the wide range of molecules, atoms and sub-atomic particles and the various types of motions and quantum jumps available to these particles. Classically, the infrared spectrum was categorized into three subregions-near, intermediate, and far infrared, depending upon the value of the infrared frequency in relation to the red spectrum. The initial reason for this classification was due to the different experimental techniques required to detect the radiation in these different bands.

3.2.1 Surface Thermal Patterns. One must be aware of the fidelity of the observed surface thermal patterns to the interior nonhomogeneities or flaws when using noncontact thermography as an NDE technique. The relationship between the surface isotherms and the interior thermal patterns is, of course, governed by the thermal conductivity of the material and the distance between the surface and an interior region of interest. For very thin materials such as composite laminates, it has been shown that the fidelity of surface thermal patterns to interior flaws is quite good (Reference 3). For bulk materials, thermography may be useful for qualitative indications of the presence of flaws but will not be nearly as good as other NDE methods for resolution of the flaw size and shape. For example, what might seem to be a rather sharp discontinuity may prove to have a weak thermal signature because of heat conduction through the material (Reference 2). The thermal signature can be improved by making the cooling rate at the surface as large as possible. This might be done by making the surface as nonreflective as possible and by augmenting radiant cooling by forced air circulation over the test surface.

3.2.2 Infrared Detectors. There are two basic types of infrared detectors: (i) photon-effect devices and (ii) thermal devices. The photon-effect devices are sensitive to the wavelength of the received radiation while thermal devices respond only to the degree of heating caused by the incident radiation and is largely independent of wavelength. The performance of real-time thermography, such as with a videothermographic system, requires that the entire field of view be scanned very rapidly so that the temperature of each field point can be measured and displayed many times each second. Such systems require the high sensitivity and very rapid response time of photon-effect devices.

MIL-HDBK-731

3.2.3 Photon-Effect Devices. Photon-effect devices utilize solid state materials which produce voltage, current, or resistance changes when irradiated by photons. These semiconductor materials are generally classified as photoemissive, photo-conductive, or photovoltaic detectors. Photoemissive detectors, originally discovered by Hertz, are materials which emit electrons when irradiated by photons having wavelengths smaller than a critical value which depends upon the material. (Another way of looking at this, of course, is that the energy or frequency of the photon must exceed a respective critical value.) Photoemissive devices are primarily responsive through the visible wavelengths down to approximately one micron. Hence, such devices are not used extensively in infrared systems. Photoconductive devices are semiconductors whose conductivity changes when irradiated by photons. The response time of photoconductor materials is very fast with times shorter than one microsecond having been reported. Photovoltaic cells are composed of p-n junction semiconductor materials. These cells produce a voltage when irradiated by photons. These devices also are characterized by a rapid response time. For maximum sensitivity, and to reduce extraneous thermal noise, it is usually necessary to cool the semiconductor material to low temperatures. Many commercially available thermographic detector systems require that liquid nitrogen be used for this purpose.

3.2.4 Applications of Detectors. The types of detectors discussed in the preceding paragraph have been incorporated into various commercially available infrared detection and viewing systems. One can obtain systems which scan the test surface in real-time as rapidly as 28 complete frames per second. The signal is conditioned and displayed upon television monitors in either gray scale or color format. The gray scale display units display continuous temperature readings using various shades of gray between black and white. The color display units select a series of distinct colors (as many as ten) to display those regions of temperature which differ from one another by a temperature band equivalent to the total temperature range divided by the number of colors available ($T=1/10$ th the temperature range for displays having ten colors). With these devices, one can monitor simply and rapidly the temperature gradient profiles on the surface of the test objects for total temperature ranges between 1 and 1,000°C. Specific information and details on particular thermographic systems can be obtained from the manufacturers.

4.0 Application of Thermographic Nondestructive Testing.

4.1 General. The sections which follow deal with the application of thermographic testing. The information will be divided into the following sections: Procedures, Equipment, Parameter Selection, and Applications.

4.2 Procedures. It will be assumed that all application procedures incorporate a thermographic detector of some type, such as a video-thermographic camera or other similar device. This part of the apparatus will be referred to simply as the "detector", and assume that the heat pattern displayed or recorded by that device is interpreted by the user in a fashion which suits his particular engineering or scientific purposes. Hence, we will be concerned in this section primarily with the production of heat patterns which display suitable detail for nondestructive testing or evaluation purposes.

4.2.1 Basic Principles of Operation. A schematic diagram of basic thermographic nondestructive testing and evaluation testing system appears in Figure 2. Regardless of how the system is used, the basic principles of operation remain essentially unchanged. Discontinuities in material properties or material geometry in the specimen under examination are revealed by corresponding discontinuities in the heat emission pattern. These are produced by using the specimen as an emitter of energy that is introduced into the specimen by an external mechanical or thermal excitation. The heat emission pattern so produced is detected by an infrared or thermographic camera (or other suitable device) and transmitted to the final system component which will display, record, and possibly interpret the heat pattern. Generally speaking, the detector and the display-recorder-interpreter are fixed for a given investigator since those components generally represent significant capital investments and sometimes require detailed integration and interfacing with other parts of the total engineering or investigative system.

MIL-HDBK-731

4.2.2 Heat Emission Patterns. On the other hand, the manner in which the heat emission pattern is produced frequently changes from specimen to specimen and from circumstance to circumstance. The choice of a specific method will generally depend on the type of flaw or defect to be detected, the material properties and geometry, the excitation devices which are available, and the nature of the thermographic detector that is available.

4.2.3 Active or Passive Heat Emitter. One of the basic choices to be made is whether the specimen is to be used as an active or passive heat emitter. While it is possible for the specimen to produce heat emission patterns by both processes simultaneously, the heat patterns emitted by most excitation devices usually fall almost completely into one of these categories. As the terminology implies, passive heat emission occurs when the specimen is used simply as a conductor or conduit for energy transmission. The details of a heat pattern produced in that way are created by spatial discontinuities in that transmission process. Hence, for the most part, the detection of defects or flaws using this method depends on the degree to which the conductivity of the specimen is distributed in local regions around those details to be revealed. Obviously, then, larger flaws which disturb the conductivity over larger areas are easier to find than smaller ones. However, the location of the flaw relative to the direction or principal heat flow, the conductivity of the material in the flaw (if it is not a void), and a number of other factors to be mentioned in the Parameter Selection section 6.0 also affect the detectability of a defect using this method.

MIL-HDBK-731

4.2.3.1 Heat Introduction by Passive Thermography. There are two commonly used schemes for introducing heat into a specimen which is to be examined by passive thermography. The first of these schemes is the introduction of heat into the specimen by conductivity, i.e., by placing a heat source in direct contact with the specimen at some point so that the specimen conducts heat away from the source, or by placing a heat sink in contact at some point so that heat is conducted by the specimen to the sink. Of course, both a heat source and a heat sink can be used together at two different points to establish a fixed temperature gradient across which heat is conducted by the specimen. Figure 3 shows two arrangements whereby heat is introduced into the specimen by conductivity. In Figure 3a the heat source and heat sink are arranged at either end of a specimen which has a small defect at the position indicated. In Figure 3b the heat source is in contact with the entire longitudinal dimension of the specimen and the other longitudinal surface is free to dissipate heat by convection. Generally speaking, the arrangement shown in Figure 3b is likely to produce a more distinct image of the defect in the heat emission pattern observed by a detector which views the free longitudinal surface in both cases, if similar amounts of heat flow are involved in the two instances. In a simple sense, the defect represents a greater disturbance in the heat flow when the direction of the flow is along the longitudinal axis.

4.2.3.2 Heat Introduction by Radiation and Convection. It is also possible to introduce heat into the specimen by radiation and convection. A flow of hot air or fluid can be directed at the surface of the specimen, for example. Two common arrangements are schematically depicted in Figure 4. The common tendency is to direct the heat source at the surface opposite to the one viewed by the detector, as shown in Figure 4a. However, it is also possible that an arrangement whereby the source of heat and the detector on the same side of the specimen may be preferable. While it is true that it is certainly easier to transfer energy into a specimen by conductivity than by radiation or convection, the latter transfer scheme does have a number of advantages. One of those advantages is simplicity of operation since it is somewhat simpler to obtain or construct a source of hot air (such as a common heat gun) or hot fluid than to build a suitable device to transfer heat into a specimen by conduction, especially if the specimen has an irregular shape or imperfect surface. In fact, it is generally easier to obtain a uniform or reproducible regular pattern of heat using radiative or conductive energy transfer into a specimen or component, a distinct advantage of such schemes.

4.2.4 Development of Heat Emission Patterns. Another basic matter of importance for passive thermography procedures is the question of whether steady-state or transient conditions should be used to develop the heat emission patterns. For a steady-state experiment, the heat source, the specimen, and all of the heat loss mechanisms are given sufficient time to reach thermal equilibrium before the thermographic data is recorded. Once the steady-state has been reached, the temperature distributions remain constant as a function of time. Such a procedure has the advantage of being more easily reproduced and more amenable to quantitative interpretations and comparisons. Once the entire system has reached thermal equilibrium, the number of operational or system-dependent variables that enter into the interpretation of the data recorded is minimized. Hence, the interpretation of the data is greatly facilitated. Also, it happens that the mathematical analysis necessary to represent a steady-state heat transfer problem is generally simpler and more easily applied to practical problems than the analysis which must be used for transient heat transfer situations. On the other hand, transient heating schemes have their advantages, too. One of the most obvious advantages is brought to mind by realizing that the largest temperature differences in a specimen occur at the first instant that a heat source is applied to the specimen. Following that first point in time, energy is transferred according to Fourier's Law and distributed in such a way so as to balance the energy input against conduction, convection, and radiation losses. The temperature gradients are reduced by this process until thermal equilibrium (a steady-state condition) is reached. While a defect or flaw represents the same obstacle to the transfer of heat during the transient as well as during the steady-state situation, the thermographic detector depends on temperature differences for the resolution of data, and these temperature differences must be detected by the observation of a free surface. Hence, in some instances, transient heating schemes may reveal defects and other discontinuities that are not easily detected by steady-state methods. Some examples will be cited in section 7.0 on Applications.

4.2.4.1 Passive Methods. The development of heat emission patterns by passive methods depends almost entirely on heat transfer characteristics for its resolution capabilities. As an analogy, consider Ohm's Law for electricity which states that the potential difference is equal to the current flow times the total electrical resistance. Similarly, Fourier's Law for thermal conduction states that the temperature difference is proportional to the conductive heat flow times the summation of thermal resistances in the region of the flaw. The effect of flaws or defects can be thought of as local variations in the thermal resistance which then is reflected in observable temperature differences in the locality of each flaw. The flaw acts like a local variation in the material property of conductivity for such passive measurements. Of course, in the engineering sense, the flaw is also a very important mechanical disturbance. That fact can be used to develop thermographic details when "active" heat generation procedures are used. Three examples of such active procedures are indicated by the schematic diagrams in Figure 5.

4.2.4.2 Hysteresis Energy Heat Patterns. Figure 5 depicts the situation in which energy is generated by hysteresis when a specimen is deformed mechanically. It is a well known fact that when most materials are cyclically deformed, even in the elastic range, some of the mechanical energy is dissipated by non-conservative micro-mechanical deformation processes such as dislocation motion, impurity diffusion, and other complex local molecular or atomic activity. For polymeric materials, these processes bring about what is commonly called viscoelastic response. The amount of energy dissipated by such mechanisms may range from imperceptible amounts up to several percent of the input energy. Unfortunately, most of the attention that has been given to hysteresis has centered on crystalline solids and has been concerned almost entirely with a part of the field called "anelasticity," which is commonly concerned with atomic diffusion events that are activated by stress including such things as grain boundary motion, single or paired solution atom motion, and twin boundary activity. While these events may be prominent in the small strain range, the heat produced by them is not significant because of the low ratios of dissipated-to-input energy, a low level of input energy for small strains and the low frequencies of oscillation at which these events are commonly excited. For composite materials with polymeric matrices, viscoelastic dissipative hysteresis dominates the heat generation, but hysteresis energy heat patterns can be generated in metal matrix composites as well.

MIL-HDBK-731

4.2.5 Generation of Heat Patterns. Two parameters are especially important in the generation of such heat patterns using mechanical excitation, as indicated in Figure 5a. The first of these is the stress or strain level at which the specimen is deformed. Depending upon the material used, the deformation process, the type of defect, and other variables, a stress or strain level greater than or equal to roughly one-third of the level required to fail the specimen is sufficient to produce observable heat patterns around defects of engineering interest in most cases. The second major parameter of importance is the cyclic frequency with which the mechanical load is applied. If other things are equal, the amount of power introduced into the specimen is directly proportional to the frequency of oscillation, so that the best frequency is the highest frequency available since temperature differences in the region of a defect will be proportional to the differential amount of energy generated by the defected and adjacent undefected regions. It should be mentioned, however, that energy dissipation mechanisms may be frequency and temperature dependent so that the optimum frequency may not be the largest one easily obtainable with the test rig available. Trial and error is called for. Most heat patterns that are generated in composite materials using this active hysteresis energy emission scheme are created by cyclic frequencies between about five and thirty Hz. One of the advantages of the mechanical excitation scheme is the fact that the dissipation of the defect or defected region is in direct proportion to its mechanical disturbance of the material response in that region. Hence, an element of interpretation is added to the information obtained in this way. It should also be mentioned that while this procedure can be used nondestructively, it is also possible to watch the growth and development of defects by simply observing the cyclic application of load levels and load histories which are sufficient to cause such growth. In that way, the chronology of damage development can be followed.

4.2.5.1 Active Heat Generation Procedure. Figure 5b shows another example of an active heat generation procedure. If proper frequencies of mechanical excitation are chosen, resonant body vibrations of the specimen or component can be excited. Energy is dissipated, and heat emission pattern is formed, in proportion to the stress distributions which are created by the resonance vibration mode. Defects and flaws, or damaged regions, are revealed not only by the manner in which they disturb the generation of heat pattern, but also by the manner in which they disturb the vibration mode shape as revealed by the heat pattern.

4.2.5.2 Vibrothermography. Figure 5c indicates yet another method of mechanical excitation which has been dubbed "vibrothermography." That procedure involves the introduction of high frequency ultrasonic excitation into a specimen by affixing an ultrasonic transducer or shaker to the specimen at some point or points. The frequency of excitation is varied in such a way that local flawed regions are set into local resonance. In addition to the hysteresis energy dissipation in the region of local vibration, another very strong source of energy dissipation, frequently develops due to the interaction of flaw surfaces when they interact with one another during local vibration motions. For example, in some cases it has been determined that the surfaces of a delamination rub together to produce a very strong dissipation source during this type of excitation. Vibrothermography has the advantageous capability of being able to selectively resolve different defects by the use of different frequencies of excitation, and the procedure has shown exceptional sensitivity to defects which have internal free surfaces which are in close proximity to one another.

4.2.5.3 Variations. While the commonly used procedures for thermographic detection of defects are outlined above, an enormous number of variations have been used and others are being developed. In fact, one of the most desirable aspects of thermography is the flexibility with which it can be applied to a variety of engineering situations. The reader and user is well advised to use his imagination and try his hand at the development of suitable procedures which may be based on the details mentioned above or on other innovative ideas.

5.0 Equipment.

5.1. General. The thermographic detector is the heart of every thermographic unit. Systems commonly in use for nondestructive evaluation range from infrared film in standard cameras to thermal imaging video devices. Generally speaking, the video devices which are available at this writing appear to be best suited to the nondestructive evaluation purposes under discussion. One of the most frequently used systems utilizes a photon device which divides incoming images into a linear string of picture parts by using two opposed-axis rotating mirrors to split up the incident image. The picture parts fall on a thallium activated indium antimonide crystal (which is cooled by liquid nitrogen) and affect its photovoltaic properties. The resulting electrical signals are used to construct a video signal string which is then displayed on a standard CRT, and may also be displayed on a ten-color-isotherm monitor. It is also possible to record and to process the image in various ways. Such a system has a temperature sensitivity of about $.1^{\circ}\text{C}$, and has the advantage of being time-resolved to about one-twentieth of a second. The operation of such a system is relatively simple since it is quite similar to a closed circuit television arrangement. Unfortunately, such systems are also rather expensive with costs commonly running to \$40,000.

5.2 Thermal Energy Source. The rest of the equipment required for a thermographic system is relatively simple and easily obtained. Referring to Figure 2, the mechanical or thermal energy source, depending upon the type of excitation to be used can be a mechanical testing machine, a dynamic shaker or shaker table, an ultrasonic transducer and power generating system, or any one of a variety of conductive or radiative heat sources. Some or all of this equipment is commonly available in a research laboratory.

5.3 Recording and Interpretation of Images. If available, it is a great luxury to have equipment which can assist in the recording and interpretation of the images obtained by the thermographic detector. Image analysis has become a very sophisticated science and art. Digital recording, analysis, enhancement, and interpretation schemes are available from a variety of sources. Although the complexity of this field is somewhat forbidding, it has a great deal to contribute to the use of thermography for nondestructive evaluation and testing purposes.

6.0 Parameter Selection.

6.1 Conductivity of Materials. There are a number of parameters which influence the capability of thermographic methods to detect flaws in materials. One of the most important of these is the conductivity of the materials to be observed. While the density and specific heat of various engineering materials rarely changes by an order of magnitude, the thermal conductivity may change by four or more orders of magnitude. Hence, thermal conductivity has a dominant influence on this material interrogation scheme in many cases. It is certainly obvious that, since the image of defects to be detected is formed by temperature differences from point to point, materials which have a very high thermal conductivity are difficult to examine with thermographic techniques since temperature differences are minimized by the high rate of heat energy transfer from point to point. There is a secondary consideration, however, which "works the other way." Thermographic detectors depend upon observations of a surface, so that any thermal information from the interior must be transmitted to the surface by conductivity. If the thermal conductivity of a material under observation is extremely low, it is possible to mask or hide thermal detail that is developed in the interior of the specimen. However, these two restrictions generally have the influence of requiring selections of different techniques and different information to be obtained rather than prohibiting the use of thermography. As we will see in the next section, thermography has been successfully applied to the detection of defects in materials as widely different in thermal properties as common metals and polymers.

6.1.1 Effect of Differential Heating. A demonstration of the essence of this effect appears in Figure 6 taken from Reference 4. It is assumed that differential heating (and therefore a thermal image) is generated over a distance given by the dimension specified in the abscissa, caused by a mechanical excitation with a frequency specified by the ordinate. The curves represent the combinations of frequency of excitation and dimension of detail which just correspond to "thermal resonance," i.e., the frequency at which thermal information can just be transmitted over the distance given by the abscissa. The ordinate, which is a logarithmic scale, clearly shows the strong dependence on material thermal conductivity.

MIL-HDBK-731

6.1.2 Thermal Image. Another consequence of thermal conductivity differences is shown in Figure 7, also taken from Reference 4. That figure shows that the apparent size of a thermal image (normalized by the actual size of the heat source) as a function of the sensitivity of the detector in units of percent of the thermal source strength over a distance of .1 of the ordinate value. For example, as shown on the figure, if the instrument used to observe a heat pattern can resolve one percent of the source strength, then the apparent size of the pattern will be about 5 or 6 times the dimensions of the actual source provided the spatial resolution of the camera is not less than that apparent size. In fact, for many practical situations, this apparent size of 5 times the source size is a useful rule of thumb. The figure is also helpful in the interpretation of information from a heat image. For specific situations it is well to solve the heat transfer problem using the classical approaches discussed widely in the literature. It should be mentioned that heat transfer problems in composite materials, especially layered composite materials, are not as straight forward as those in homogenous isotropic materials. Discussions of such problems can be found in References 4 through 7.

6.1.3 Surface Reflectivity. Surface reflectivity and emissivity are also parameters of importance. The reflection of radiant energy from the surface of a specimen under observation may interfere greatly with attempts to observe and record the heat emission pattern being developed by the specimen. For the thermal radiation band in the electromagnetic spectrum (defined as the portion of the spectrum between wavelengths of about 1×10^{-7} m and 1×10^{-4} m) reflectivity is influenced not only by the material properties but also by the surface condition. Hence, it is very difficult to classify different surface and corresponding quantitative reflectivities. It is best to determine by experiment in one's own laboratory the degree to which reflectivity will interfere with the observation of thermal data. The radiant energy from a lightbulb, a human body, or other heat source will generate glaring reflections off polished aluminum, for example, while a number of other surfaces, especially those paints with so-called "flat" finishes, show very little reflectivity (Reference 8).

6.1.4 Emissivity of the Surface. The emissivity of the surface is a measure of its ability to emit radiant thermal energy per unit time and unit area, usually normalized by the emissivity of an ideal "black body" as defined in common physics texts. To that extent, for our purposes, the emissivity represents the ability of a surface to transmit the thermal information of interest that is developed in the interior of a body. Emissivity generally depends upon the material or substance, the surface condition (including roughness), and the temperature. Values of emissivity are widely tabulated and quoted (c.f. Reference 9).

6.1.5 Damping Characteristics of Materials. One other parameter is sufficiently general as to require discussion. That parameter is the damping characteristics of materials, especially fiber reinforced composite materials. When mechanical excitation is used to develop heat images, the ability of a material to develop such images is completely controlled by its hysteresis characteristics, commonly known as damping. The damping or damping ratio of materials is difficult to measure and may depend upon temperature and frequency. The damping and dynamic mechanical behavior of fiber reinforced composites has been discussed in a review article by Gibson (Reference 10) and another excellent discussion of experimental techniques in an article by Gibson and Plunkett (Reference 11). A discussion of heat emission of composite materials under mechanical fatigue loading is also provided in Reference 12. In general, one might expect, materials which have complicated microstructures, and especially those which have viscoelastic behavior, usually dissipate energy efficiently and develop strong heat images. Since many of these materials are also relatively poor conductors, they are ideal for the application of thermography as a nondestructive evaluation scheme.

7.0 Applications.

MIL-HDBK-731

7.1 Principles. The principle of thermography for nondestructive testing and evaluation purposes appears to be for the detection of defects and flaws and the general monitoring of damage development and growth. In 1969 Schultz and Tsai (Reference 13) discussed the damping of composite materials and indicated that the energy loss due to damping was dependent upon the frequency of oscillation and the orientation of the orthotropic materials relative to the axis of mechanical excitation. In a subsequent report Segol and Tauchert (Reference 14) measured the plastic specimens at frequencies of 120, 210, and 300 cycles per minute. They found large temperature increases and observed discoloration and delamination in the glass-epoxy composite materials with a consequent reduction in properties.

7.1.1 History. The use of thermography to detect flaws and defects, and to follow damage development, began in about 1974 (Reference 15 and 16). It was found that thermography is especially useful to follow the complex development or damage in the vicinity of notches such as holes in composite laminates. Boron-aluminum and boron-epoxy materials were used in those early studies.

7.2 Techniques. As techniques have been developed, methods to detect defects and damage development in unnotched composite laminates have been devised and considerable success has been reported (Reference 17). It has also been determined that thermography is especially sensitive to certain specific types of damage in composite laminates. Perhaps the most obvious such conclusion in the literature is that thermography is especially sensitive to debonds and delaminations (Reference 18 and 19). This appears to be true when either mechanical excitation or convective-radiative incident heat is used (Reference 20). In fact, resonant vibration (of the body vibration or local vibration type) has been found to be an especially sensitive method for the excitation of heat patterns generated by internal defects which have a free surface such as debonds, delaminations, or cracks (Reference 21). Mignogna and Green have also reported that resonant vibrations created by high-power ultrasound can also be used to detect the nature of internal boundaries (Ref.22).

MIL-HDBK-731

7.3 Rapid Observation of Surfaces. Since thermography works on the basis of optical field techniques, it can be applied to the quick observation of large surfaces. Because of that characteristic, it is especially suited to the quick scanning of engineering structures for the detection of defects and the identification of regions that should be examined more carefully. Also, if video thermographic equipment is used, the time resolution of the system permits the detection and recording of some of the dynamic aspects of damage development, and in some instances can be a major advantage in the sense that systems that are being dynamically tested or used for some engineering purpose do not have to be interrupted for observation.

8.0 Precautions

8.1 General Composite structures subject to thermographic nondestructive inspection have temperature limits beyond which irreversible matrix damage can occur. Care should be taken not to exceed these limits.

Custodian:

Army -- MR
Navy -- AS
Air Force -- 20

Preparing Activity:

Army -- MK
Project No. NDTI-0067

Review Activities:

Army -- MI, AV, AT
Navy -- SH
Air Force --99, 82

User Activities:

Navy -- OS
Air Force -- 84, 80

(WP ID#-5051/DISC-0063B - AMMRC USE ONLY)

MIL-HDBK-731

References

1. "Thermography--An NDI Method for Damage Detection," by E. G. Henneke, II, K. L. Reifsnider and W. W. Stinchcomb, Journal of Metals 31, pp. 11-15, Sept. 1979.
2. "Thermal and Infrared Testing," by R. E. Engelhardt and W. A. Hewgley, Nondestructive Testing--A Survey, NASA SP-5113, U. S. Government Printing Office, pp. 119-140, 1973.
3. "Detection of Damage in Composite Materials by Vibrothermography," E. G. Henneke, II and T. S. Jones, Nondestructive Evaluation and Flaw Criticality for Composite Materials, STP 696 (American Society for Testing and Materials, Philadelphia, 1979).
4. Reifsnider, K. L., Henneke, E. G. and Stinchcomb, W. W., "The Mechanics of Vibrothermography," Mechanics of Nondestructive Testing, W. W. Stinchcomb, E., Plenum Press, New York, 1980.
5. Jones, T. S., "Thermographic Detection of Damaged Regions in Fiber-Reinforced Composite Materials," Thesis for Master of Science, Engineering Science and Mechanics Dept., School of Engineering, Virginia Polytechnic Institute and State University, April 1977.
6. Mageal, A., Bache, T. C. and Hegemeir, G. A., "A Continuum Model for Diffusion in Laminated Composite Media," Journal of Heat Transfer, Vol. 98 (Feb. 1976) pp. 133-135.
7. Estes, R. C. and Mulholland, G. P., "Diffusion Through Orthotropic Rectangular Laminated Composites," Fibre Science and Technology, Vol. 7, (Oct. 1974) pp. 257-279.
8. McLaughlin, P.V., McAssey, E. V. and Deitrich, R. C., "Non-destructive Examination of Fibre Composite Structures by Thermal Field Techniques," NDT International (April 1980) pp. 58-62.

MIL-HDBK-731

9. Susec, J., Heat Transfer, Simon and Schuster, New York, 1980.
10. Gibson, R. F., "Dynamic Mechanical Behavior of Fiber-Reinforced Composites: Measurement and Analysis," Journal of Composite Materials, Vol. 10 (Oct. 1976) pp. 325-341.
11. Gibson, R. F. and Plunkett, R., "Dynamic Stiffness and Damping of Fiber-Reinforced Composite Materials," Shock and Vibration Digest, Vol. 9, No. 2 (1977) pp. 9-17.
12. Hahn, H. T. and Kim, R. Y., "Fatigue Behavior of Composite Laminates," Journal of Composite Materials, Vol. 10 (April 1976) pp. 156-180.
13. Schultz, A. B. and Tsai, S. W., "Measurements of Complex Dynamic Moduli for Laminated Fiber-Reinforced Composites," Journal of Composite Materials, Vol. 3 (July 1969) pp. 434-443.
14. Segol, G. and Tauchert, T. R., "An Experimental Study of the Heat Generated During Cyclic Deformations of Glass-Epoxy Composites," Technical Report No. 21 (Dec. 1979) Department of the Army, U. S. Army Research Office--Durham, Contract DAHCO4-69-C-0062.
15. Reifsnider, K. L. and Stinchcomb, W. W., "Investigation of Dynamic Heat Emission Patterns on Mechanical and Chemical Systems," Proc. of 2nd Biennial Infrared Information Exchange, AGA Corporation, St. Louis, MO (1974) pp. 45-48.
16. Reifsnider, D. L. and Williams, R. S., "Determination of Fatigue-Related Heat Emission in Composite Materials," Experimental Mechanics, Vol. 14 (1974) pp. 45-48.
17. Henneke, E. G., Reifsnider, K. L. and Stinchcomb, W. W., "Thermography--An NDI Method for Damage Detection," Journal of Metals, Vol. 31 (1979) pp. 1115-1117.

MIL-HDBK-731

18. Wilson, D. W. and Charles, J. A., "Thermographic Detection of Adhesive-bond and Interlaminar Flaws in Composites," Experimental Mechanics (July 1981) pp. 276-280.
19. Henneke, E. G. II and Jones, T. A., "Detection of Damage in Composite Materials by Vibrothermography," Nondestructive Evaluation and Flaw Criticality for Composite Materials, STP 696, American Society for Testing and Materials, Philadelphia, PA (1979).
20. McLaughlin, P. V., McAssey, Jr., E. V. and Deitrich, R. C., "Aerostructure Nondestructive Evaluation by Thermal Field Techniques," Report No. NAEC-92-131, Naval Air Systems Command (March 1979).
21. Pye, C. J. and Adams, R. D., "Detection of Damage in Fibre Reinforced Plastics Using Thermal Fields Generated During Resonant Vibration," NDT International (June 1981) pp. 111-118.
22. Mignogna, R. B. and Green, R. E. Jr., "Nondestructive Evaluation of the Effects of Dynamic Stress Produced by High-Power Ultrasound in Materials," The Mechanics of Nondestructive Testing, Plenum Press, New York, 1980.

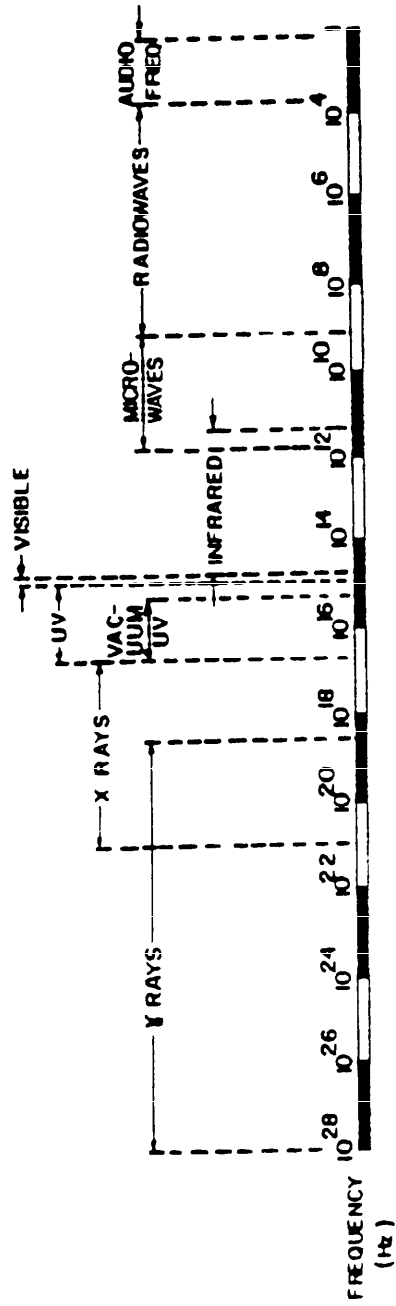

Figure 1. The electromagnetic spectrum.

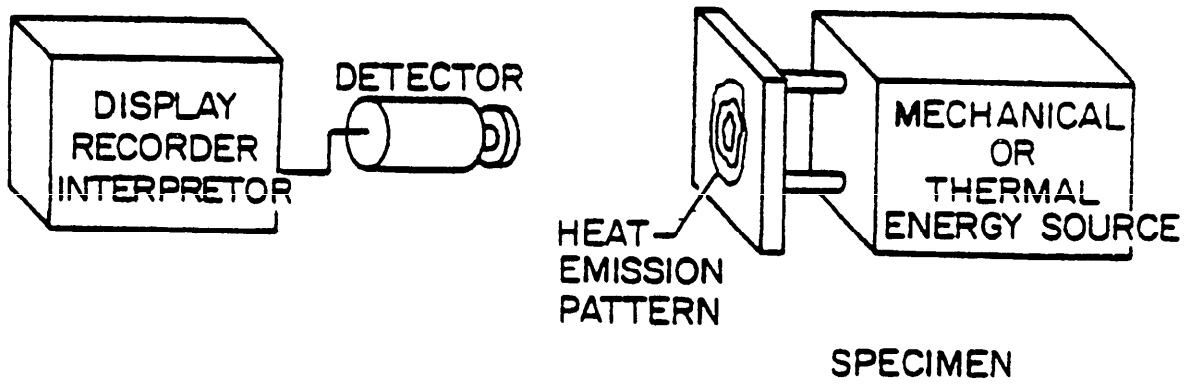

Figure 2. Schematic diagram of a basic thermographic NDE system.

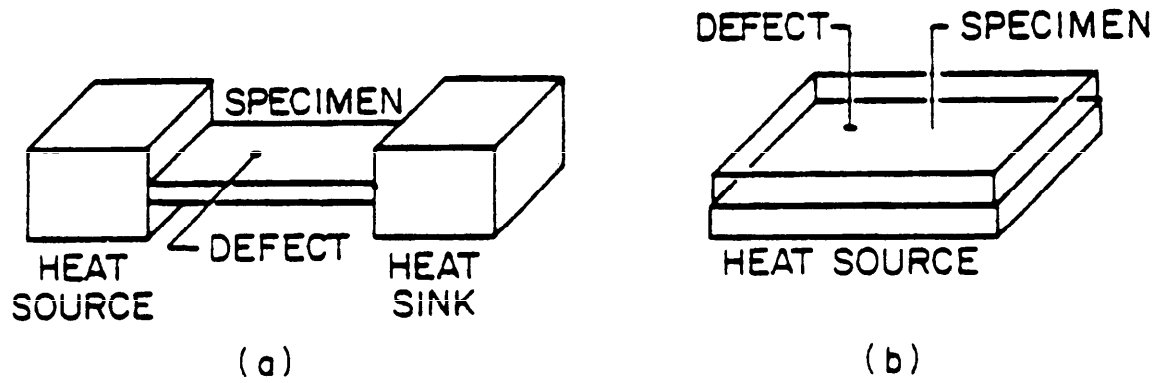

Figure 3. Examples of arrangements for introducing heat into a specimen by conduction.

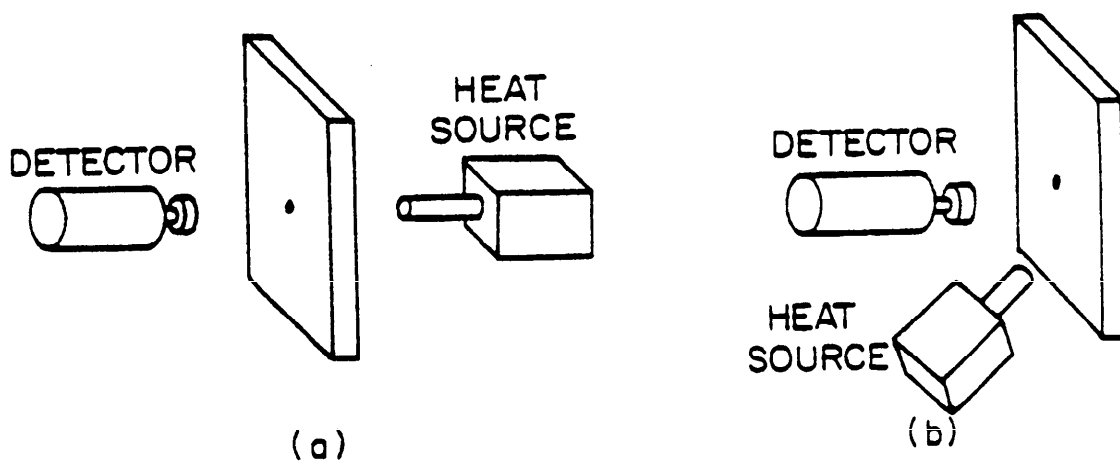
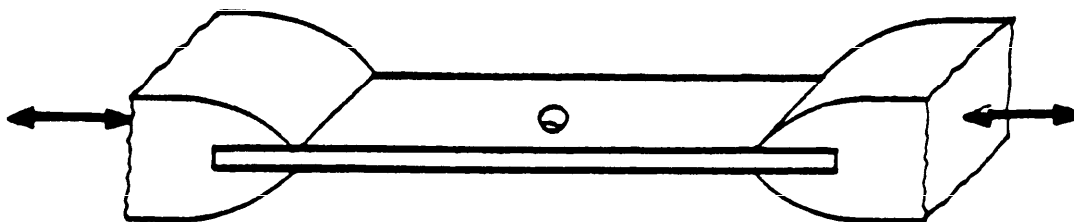
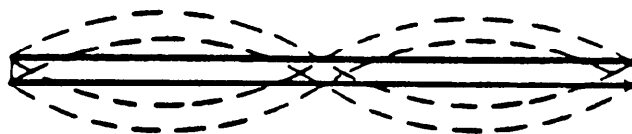

Figure 4. Examples of arrangements for introducing heat into a specimen by radiation and convection.



Uniform Mechanical Deformation
(a)



Body Resonance
(b)

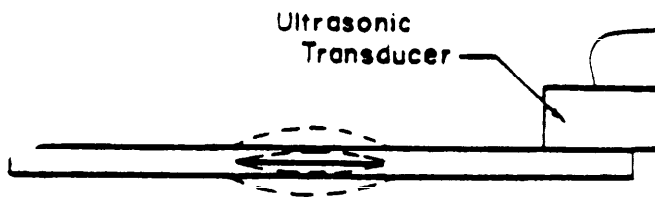

Local Resonance
(c)

Figure 5. Examples of heat generation by active techniques.

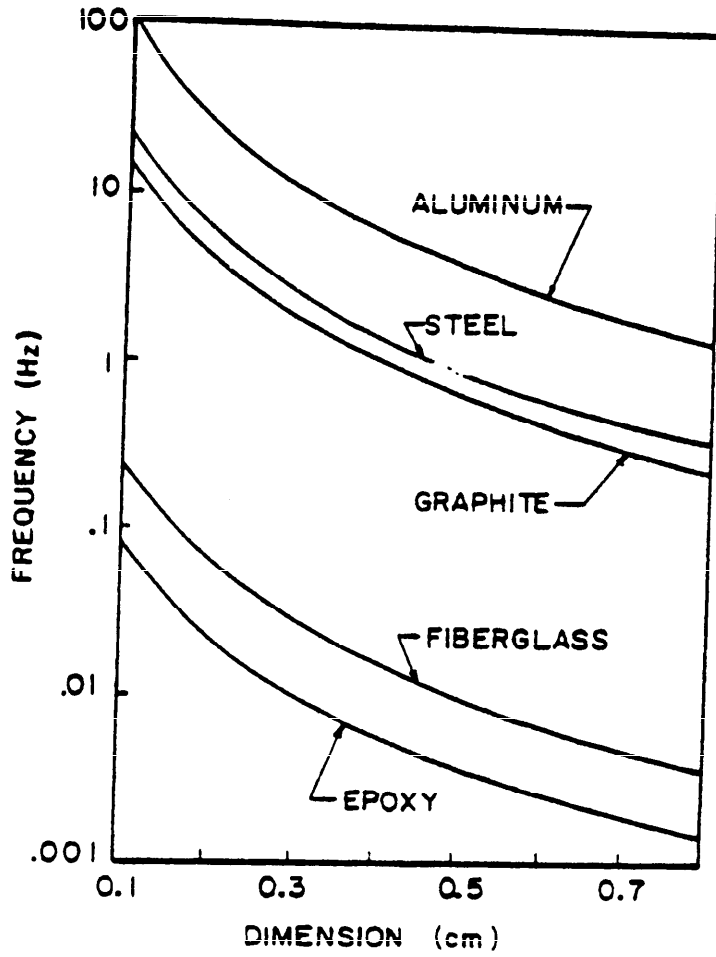

Figure 6. Region size dimension effect on relaxation frequency.

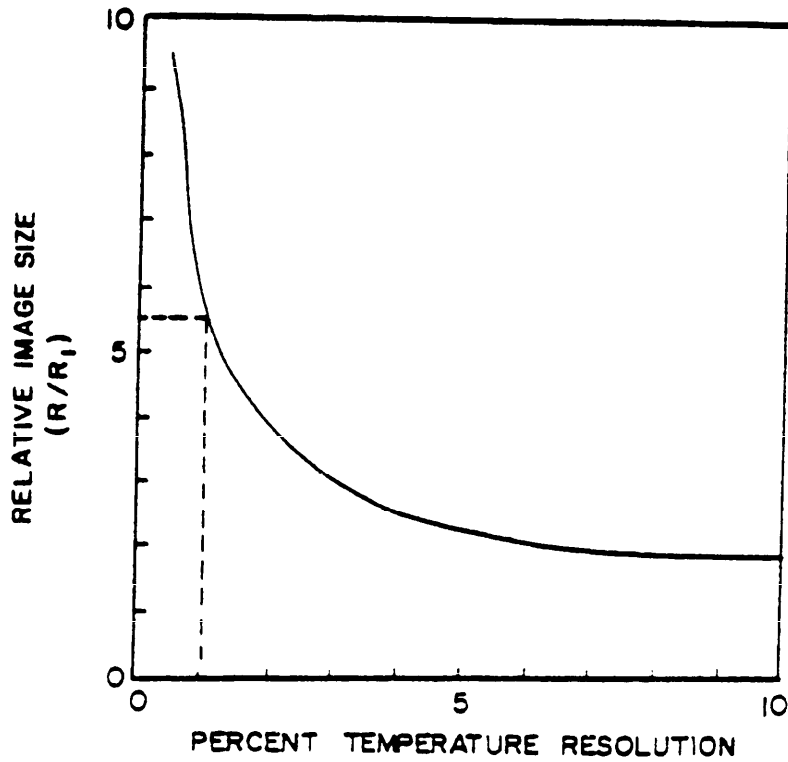

Figure 7. Percent difference between successive points on the temperature distribution at a source for a change of 0.1 in r/r_1 .

INSTRUCTIONS: In a continuing effort to make our standardization documents better, the DoD provides this form for use in submitting comments and suggestions for improvements. All users of military standardization documents are invited to provide suggestions. This form may be detached, folded along the lines indicated, taped along the loose edge (*DO NOT STAPLE*), and mailed. In block 5, be as specific as possible about particular problem areas such as wording which required interpretation, was too rigid, restrictive, loose, ambiguous, or was incompatible, and give proposed wording changes which would alleviate the problems. Enter in block 6 any remarks not related to a specific paragraph of the document. If block 7 is filled out, an acknowledgement will be mailed to you within 30 days to let you know that your comments were received and are being considered.

NOTE: This form may not be used to request copies of documents, nor to request waivers, deviations, or clarification of specification requirements on current contracts. Comments submitted on this form do not constitute or imply authorization to waive any portion of the referenced document(s) or to amend contractual requirements.

(Fold along this line)

(Fold along this line)

DEPARTMENT OF THE ARMY



NO POSTAGE
NECESSARY
IF MAILED
IN THE
UNITED STATES

OFFICIAL BUSINESS
PENALTY FOR PRIVATE USE \$300

BUSINESS REPLY MAIL
FIRST CLASS PERMIT NO. 12062 WASHINGTON, D C

POSTAGE WILL BE PAID BY THE DEPARTMENT OF THE ARMY

Army Materials & Mechanics Research Center
ATTN: DRXMR-SMS
Watertown, MA 02172



STANDARDIZATION DOCUMENT IMPROVEMENT PROPOSAL

(See Instructions - Reverse Side)

1. DOCUMENT NUMBER		2. DOCUMENT TITLE	
3a. NAME OF SUBMITTING ORGANIZATION		4. TYPE OF ORGANIZATION (Mark one)	
b. ADDRESS (Street, City, State, ZIP Code)		<input type="checkbox"/> VENDOR	
		<input type="checkbox"/> USER	
		<input type="checkbox"/> MANUFACTURER	
		<input type="checkbox"/> OTHER (Specify): _____	
5. PROBLEM AREAS			
a. Paragraph Number and Wording:			
b. Recommended Wording:			
c. Reason/Rationale for Recommendation:			
6. REMARKS			
7a. NAME OF SUBMITTER (Last, First, MI) - Optional		b. WORK TELEPHONE NUMBER (Include Area Code) - Optional	
c. MAILING ADDRESS (Street, City, State, ZIP Code) - Optional		8. DATE OF SUBMISSION (YYMMDD)	