

METRIC

MIL-PRF-26514G
1 August 1995
SUPERSEDING
MIL-P-26514F
18 December 1987

PERFORMANCE SPECIFICATION

POLYURETHANE FOAM, RIGID OR FLEXIBLE, FOR PACKAGING

This specification is approved for use by all Departments and Agencies of the Department of Defense.

1. SCOPE

1.1 Scope. This specification covers prefoamed polyurethane foams, both rigid and flexible, for packaging applications.

1.2 Classification. The polyurethane foams shall be furnished in the following classes, categories, and grades. Additional characteristics shall be specified by the procuring activity (see 6.2).

Type I - Standard Foam

Class 1 - Rigid
Class 2 - Flexible

Grade A (Figure 1)
Grade B (Figure 2)
Grade C (Figure 3)
Grade D (Figure 4)

Type II - Deleted (see 6.8)

Beneficial comments (recommendations, additions, deletions) and any pertinent data which may be of use in improving this document should be addressed to the Air Force Packaging Technology and Engineering Facility, AFMC LSO/LOP, 5215 Thurlow Street, Wright Patterson AFB OH 45433-5540, by using the self-addressed Standardization Document Improvement Proposal (DD Form 1426) appearing at the end of this document or by letter.

AMSC N/A

FSC 8135

DISTRIBUTION STATEMENT A. Approved for public release; distribution is unlimited.

MIL-PRF-26514G

Type III - Anti-static Foam

- Class 1 - Rigid
- Class 2 - Flexible

- Grade A (figure 1)
- Grade B (figure 2)
- Grade C (figure 3)
- Grade D (figure 4)

2. APPLICABLE DOCUMENTS

2.1 General. The documents listed in this section are specified in sections 3 and 4 of this specification. This section does not include documents listed in other sections of this specification or recommended for additional information or as examples. While every effort has been made to ensure the completeness of this list, document uses are cautioned that they must meet all specified requirements documents cited in sections 3 and 4 of this specification, whether or not they are listed.

2.2 Government documents.

2.2.1 Specifications, standards, and handbooks. The following specifications and standards form a part of this document to the extent specified herein. Unless otherwise specified, the issues of these documents are those listed in the issue of the Department of Defense Index of Specifications and Standards (DODISS) and supplement thereto, cited in the solicitation (see 6.2).

SPECIFICATIONS

Federal

QQ-A-225/6 Aluminum Alloy 2024, Bar, Rod and Wire;
Rolled, Drawn or Cold Finished

STANDARDS

Federal

FED-STD-101 Test Procedures for Packaging Materials
FED-STD-595 Colors Used in Government Procurement

MIL-PRF-26514G

(Unless otherwise indicated, copies of the above specifications, standards and handbooks are available from the Standardization Documents Order Desk, Building 4D, 700 Robbins Ave., Philadelphia PA 19111-5094.)

2.3 Non-Government publications. The following documents form a part of this document to the extent specified herein. Unless otherwise specified, the issues of the documents which are DOD adopted are those listed in the issue of the DODISS cited in the solicitation. Unless otherwise specified, the issues of documents not listed in the DODISS are the issues of the documents cited in the solicitation (see 6.2).

ASTM

- D 1621 Standard Test Methods for Compressive Properties of Rigid Cellular Plastics
- D 1596 Standard Test Method for Dynamic Shock Cushioning Characteristics of Packaging Material
- D 2126 Standard Test Method for Response of Rigid Cellular Plastics to Thermal and Humid Aging

(Application for copies should be addressed to ASTM, 1916 Race Street, Philadelphia PA 19103-1180.)

ANSI/IPC

- IPC-MF-150 Metal Foil for Printed Wiring Applications (DOD adopted)

(Application for copies should be addressed to the Institute for Interconnecting and Packaging Electronic Circuits, 7380 North Lincoln Ave., Lincolnwood IL 60646-1797.)

(Non-Government standards and other publications are normally available from the organizations that prepare or distribute the documents. These documents may also be available in or through libraries or other informational services.)

2.3 Order of precedence. In the event of a conflict between the text of this document and the references cited herein, the text of this document takes precedence. Nothing in this document, however, supersedes applicable laws and regulations unless a specific exemption has been obtained.

3. REQUIREMENTS

3.1 First article. When specified (see 6.2), a sample shall be subjected to first article inspection (see 6.3) in accordance with 4.3.2.

MIL-PRF-26514G

3.2 Materials. The materials used in the production of polyurethane foams shall provide a product conforming to the requirements specified herein. Procurement of materials that contain chlorofluorocarbons (CFCs), or utilize or liberate CFCs during their production, is prohibited. The polyurethane foam shall be supplied in rolls, sheets, or molded shapes, as specified (see 6.2).

3.3 Hydrolytic stability. Unless otherwise specified (see 6.2 and 6.5), all materials shall meet the requirements of 3.3.1 or 3.3.2 as applicable.

3.3.1 Class 1. After aging in accordance with 4.5.3.1, the average minimum compressive strength of the 15 samples tested in both the parallel and the perpendicular directions (see 4.5.3.1.1) at yield or 10 percent deflection, whichever occurs first, shall not vary more than 10 percent from the average value of the 15 samples tested in both the parallel and the perpendicular directions obtained prior to aging (compressive strength samples, see 4.5.3.8 and 6.6). It is not necessary for both yield and ten percent deflection to occur.

3.3.2 Class 2. After aging in accordance with 4.5.3.1, the stresses necessary for 20 and 40 percent strains shall be within ± 10 percent of the stresses necessary to cause these same strains on the same unaged specimens when tested in accordance with 4.5.3.1.2.

3.4 Water absorption (class 1 only). The average water absorption by weight of all samples shall not exceed 170 percent when determined in accordance with 4.5.3.2.

3.5 Creep (class 2 only). Unless otherwise specified (see 6.2), the maximum percentage creep that occurs under the required continuous loading stress shall not exceed 10 percent when tested in accordance with 4.5.3.3.

3.6 Compression set (class 2 only). Unless otherwise specified (see 6.2), the compression set shall not be more than 10 percent of the original thickness (see 4.5.3.4).

3.7 Pliability (class 2 only). Unless otherwise specified (see 6.2), the material shall show no cracks, tears, or separations when tested in accordance with 4.5.3.5. This requirement is limited to materials having a density of 64 kg/m³ or less.

3.8 Dimensions.

3.8.1 Molded or machined shapes. Special shapes (other than rolls or sheets) shall be of the configuration and dimensions as specified (see 6.2).

MIL-PRF-26514G

3.8.2 Roll or sheet stock. The length, width, and thickness shall be as specified by the procuring activity (see 6.2). When procuring material, the tolerance for lengths, widths, and thicknesses shall be ± 3 mm.

3.9 Volume change. The average change in volume of all of the polyurethane foam samples after aging shall be no greater than seven percent of the initial volumes before aging (see 4.5.3.6).

3.10 Relative combustibility. The polyurethane foam shall be tested in accordance with 4.5.3.7. The flame front of each test specimen shall not advance to or beyond the 125 mm gage mark specified in the test. There shall be no visual evidence of burning or melting of any specimen at or beyond the 125 mm gage mark.

3.11 Compressive strength (class 1 only). Unless otherwise specified (see 6.2), the minimum compressive strength at yield or 10 percent deflection, whichever occurs first, shall be 140 kPa with the force applied parallel and 85 kPa with the force applied perpendicular to the direction of foam rise (see 4.5.3.8 and 6.6). It is not necessary for both yield and ten percent deflection to occur. Failure of the average compressive strength value of any set of five specimens to conform to the above requirements shall be cause for rejection.

3.12 Dynamic cushioning properties (class 2 only). The peak G-static stress curves for grades A, B, C, and D shall conform to the shapes of the appropriate generalized curves presented in figures 1, 2, 3, and 4, respectively, within the specified tolerance bands, of ± 20 percent, when tested in accordance with 4.5.3.9. Five G-static stress points, approximately equally spaced, shall be required to establish conformance. Two points shall be established within 10 percent of the static stress values at the extremities of the curve and one at the approximate minimum peak acceleration level point.

3.13 Anti-static property (type III only). The cushioning material shall be uniformly impregnated with an anti-static agent. The static decay rate of the impregnated foam shall not exceed two seconds when tested as specified in 4.5.3.10.

3.14 Color coding (class 2 only). Unless otherwise specified (see 6.2 and 6.7), cushioning material grade and anti-static properties shall be identified according to color. Coding colors shall correspond to color numbers of FED-STD-595. The colors shall be evenly dispersed throughout the material. The material, grade, color, and color code number shall be:

MIL-PRF-26514G

Type I, Class 2 - Standard Foam

<u>Grade</u>	<u>Color</u>	<u>FED-STD-595 No.</u>
A	Blue	35550
B	Green	34672
C	Charcoal	36118

Type III, Class 2 - Anti-Static Foam

<u>Grade</u>	<u>Color</u>	<u>FED-STD-595 No.</u>
A	Yellow	23655
B	Red	31302
C	Brown	30117

3.15 Corrosivity. Anti-static cushioning material (type III) shall not cause corrosion when tested as specified in 4.5.3.11.

4. VERIFICATION

4.1 Classification of inspections. The inspection requirements specified herein shall be classified as follows:

- a. First article inspection (4.3.2).
- b. Conformance inspection (4.3.3).

4.2 Sampling. Guidance for sampling procedures is provided in 6.4. For purposes of sampling, a lot shall consist of all material produced under like conditions in one unchanged process by one manufacturer and submitted for acceptance at one time.

4.3 Inspection and tests.

4.3.1 First article waiver. First article inspection may be waived, by the Air Force Packaging Technology and Engineering Facility (AFPTEF) or the procuring activity, when the procuring activity or contract administrator has data or other evidence to indicate that prior successful first article inspection has been conducted (see 6.2). Only when the first article has been waived by the AFPTEF or procuring activity, may the contractor self-certify that the material will conform to the requirements of this specification.

4.3.2 First article inspection. First article inspection shall consist of all tests in Table I and shall be performed by the AFPTEF, after award of contract and prior to production. First article inspection shall be performed on sample units produced using materials, equipment, and procedures which will be used in fulfilling the contract. First article approval is valid only on the contract on which it is granted, unless extended by the Government to other contracts (see 3.1, 6.3, and 6.9).

MIL-PRF-26514G

TABLE 1. EMI Anodic Test Requirements and Methods

PROPERTIES	REQUIREMENTS		TEST METHODS	SIZE		QUANTITY	ORIENTATION (see figure 4)
	Class 1	Class 2		Class 1	Class 2		
Form	3.2	3.2	4.4				
Hydrolytic Stability	3.3.1	3.3.2	4.5.3.1	100 mm ± 100 mm ± 50 mm 100 mm ± 100 mm ± 50 mm N/A	N/A N/A 200 mm ± 200 mm ± 75 mm (150 mm ± 150 mm ± 75 mm, grade D)	15 (5beam) 15 (5beam) 3	parallel perpendicular parallel
	3.4	N/A	4.5.3.2	100 mm ± 100 mm ± 25 mm	N/A	3	parallel
	Crep	N/A	4.5.3.3	N/A	150 mm ± 150 mm ± 75 mm	3	parallel
Compression Set	N/A	3.6	4.5.3.4	N/A	150 mm ± 150 mm ± 75 mm	3	parallel
Pliability	N/A	3.7	4.5.3.5	N/A	150 mm ± 150 mm ± 13 mm	3	parallel
Dimensions Special Shapes Rolls, Sheets	3.8	3.8	4.5.1.1				
	3.8.1	3.8.1	4.5.1.1				
	3.8.2	3.8.2	4.5.1.1, 4.5.1.2				
Volume Change	3.9	3.9	4.5.3.6	100 mm ± 100 mm ± 50 mm	250 mm ± 250 mm ± 75 mm (150 mm ± 150 mm ± 75 mm, grade D)	3	parallel
Combustibility	3.10	3.10	4.5.3.7	150 mm ± 50 mm ± 10 mm	150 mm ± 50 mm ± 10 mm	5	parallel
Compressive Strength	3.11	N/A	4.5.3.8	100 mm ± 100 mm ± 50 mm.	N/A	15 (5beam) 15 (5beam)	parallel perpendicular
Dynamic Cushioning	N/A	3.12	4.5.3.9	N/A	250 mm ± 250 mm ± 75 mm (150 mm ± 150 mm ± 75 mm, grade D)	3	parallel
Anis. Static Property (Type III only)	3.13	3.13	4.5.3.10	75 mm ± 125 mm ± 10 m	75 mm ± 125 mm ± 10 mm	3	parallel
Comativity Test (Type III only)	3.15	3.15	4.5.3.11	75 mm ± 125 mm ± 10 m	75 mm ± 125 mm ± 10 mm	3	parallel

MIL-PRF-26514G

4.3.3 Conformance inspection. Quality conformance tests shall consist of all tests in table II.

TABLE II. Conformance Test Requirements.

PROPERTIES	TEST METHOD
Examination of Dimensions	4.5.1.1
Thickness	4.5.1.2
Combustibility	4.5.3.7
Color Coding (type III, class 2 only)	4.4
<u>Anti-Static (type III, class 2 only)</u>	<u>4.5.3.10</u>

4.4 Visual inspection. Item shall be inspected for defects listed in table III.

TABLE III. Classification of defects.

INSPECT	DEFECT	CLASSIFICATION
Form	Not as specified (see 3.2 and 6.2)	major
<u>Color</u>	<u>Not as specified (see 3.14 and 6.2)</u>	<u>minor</u>

4.5 Testing. The tests specified in tables I and II shall be performed to assure compliance with the requirements of Section 3.

4.5.1 Preparation of test specimens. Unless otherwise specified, all test specimens shall be the following sizes (see table 1). Class 1 test specimens shall be rectangular, having dimensions of 100 mm x 100 mm x 50 mm. Class 2, grades A, B, and C test specimens shall be rectangular, having dimensions of 200 mm x 200 mm x 75 mm. Class 2, grade D test specimens shall be rectangular, having dimensions of 150 mm x 150 mm x 75 mm. All test specimens shall have a tolerance for length, width, and thickness of ± 2 mm, regardless of specimen size. The length and width of the specimens shall be measured at the center lines. They shall not be subjected to any mechanical or chemical treatment prior to testing except as specifically described herein. The specimens shall be cut so as to avoid rounded or precompressed edges.

4.5.1.1 Examination of dimensions. The length and width of rolls, sheets or pads shall be measured to determine conformance to 3.8. The dimensions of molded and machined shapes shall be examined for conformance to the requirements specified.

4.5.1.2 Thickness. Measure thickness by placing the specimen on a flat, level surface. Load its entire top surface to 175 Pa \pm

MIL-PRF-26514G

35 Pa using a rigid, flat plate. Apply this load for 30 seconds and then measure the vertical distance between the base surface and the bottom of the loading plate to the nearest 2 mm. This measurement may be made either by a single point at the center of the cushion top surface or at each of the four corners of the sample. If the four-corner method is used, the average of the four measurements shall be the thickness of the specimen. The thickness of the material shall be the average thickness of the specimens used for testing.

4.5.1.3 Preworking. When required, prework specimens using a compression machine (Instron Compression Tester or equivalent). The machine shall utilize 2 parallel rigid plates large enough to cover the entire surface of a specimen.

a. Set the initial and final distance between the compression plates as specified in the appropriate procedures.

b. Program the machine to compress each specimen 10 times at a rate of 250 mm per minute.

4.5.2 Test conditions. Unless otherwise specified, tests and measurements shall be made at room temperature, 21°C to 27°C. In case of dispute or rejection, the specimens shall be conditioned at 23°C ± 1°C and 50 percent relative humidity (RH) ± 5 percent RH for at least 16 hours before being tested.

4.5.3 Test methods.

4.5.3.1 Hydrolytic stability. The hydrolytic stability test shall be performed using the appropriate test sequence specified below. Except for aging, the environmental conditions of 4.5.2 shall apply. Aging shall consist of exposure of test specimens for 14 days at 70°C ± 1°C and 95 percent RH ± 5 percent RH. After exposure, the specimens shall be subjected to 49°C ± 1°C in a mechanically convected dry air oven for 24 hours.

4.5.3.1.1 Test sequence for class 1 materials. Hydrolytic stability for class 1 materials shall be determined on samples obtained after a minimum 72-hour cure time. Five specimens, 100 mm x 100 mm x 50 mm, shall be cut from each of three 400 mm x 400 mm x 400 mm single pour blocks of foam (see table 1) such that the dimension of thickness (50 mm) is parallel to the direction of foam rise (see figure 5). Additionally, five specimens, 100 mm x 100 mm x 50 mm, shall be cut from each of three sample blocks such that the dimension of sample thickness (50 mm) is perpendicular to the direction of foam rise (see figure 5). Specimens shall be aged as specified in 4.5.3.1. These specimens shall then be tested for compressive strength values, as specified in 4.5.3.8, at yield or ten percent deflection, whichever occurs first. It is not necessary for both yield and ten percent deflection to occur. Failure of the average compressive strength value, recorded for each set of five

MIL-PRF-26514G

specimens, to conform to the requirements of 3.3.1 shall be cause for rejection.

4.5.3.1.2 Test sequence for class 2 materials.

a. For grades A, B, and C, cut three samples, 200 mm x 200 mm x 75 mm. For grade D material, cut three samples, 150 mm x 150 mm x 75 mm. For all grades, cut the specimens with the dimension of sample thickness (75 mm) parallel to the direction of foam rise (see figure 5), prepared in accordance with 4.5.1 (see table 1).

b. Condition specimens in accordance with 4.5.2.

c. Measure the original thickness in accordance with 4.5.1.2.

d. Prewrite the specimens in accordance with 4.5.1.3, compressing them 65 percent of their original thickness.

e. One hour after preworking the specimens, measure initial thickness for the load/deflection test in accordance with 4.5.1.2.

f. Perform the load/deflection test in accordance with 4.5.3.1.3 using the initial thickness from 4.5.3.1.2.e to determine the 20 and 40 percent strain points.

g. Age the specimens as specified in 4.5.3.1.

h. Condition specimens for a minimum of 60 minutes in accordance with the temperature and humidity conditions of 4.5.2.

i. Prewrite the specimens in accordance with 4.5.1.3, compressing them 65 percent of their original thickness.

j. One hour after preworking, repeat the load/deflection test on aged specimens in accordance with 4.5.3.1.3 using the initial thickness from 4.5.3.1.2.e to determine the 20 and 40 percent strain points.

k. To determine compliance with 3.3.2, use the pre-aging and post-aging load/deflection test data to calculate the percent of change for specimens cut parallel to the direction of foam rise. The percent of change averages for the three specimens shall be used to comply with 3.3.2, with the absolute numbers used (regardless of the \pm signs).

4.5.3.1.3 Load/deflection (class 2 only). Three test specimens shall be prepared in accordance with 4.5.1 and placed in a compression machine (Instron Compression Tester, or equal) or a weight-increment type device. The specimens shall be preworked prior to testing. Prewrite shall consist of compressing the specimens between parallel, rigid plates 65 percent of their

MIL-PRF-26514G

original measured thickness. Compress a total of 10 times at a rate of 250 mm per minute. Three minutes after completion of the last compression, the thickness of the specimen shall be measured to the nearest 2 mm after preloading to 175 Pa \pm 35 Pa. The thickness after prework shall be used as the zero deflection point. The specimens shall be loaded at a rate of 5 mm per minute. The load shall be recorded at 20 and 40 percent strains, based on the thickness at the start of loading.

4.5.3.2 Water absorption (class 1 only). Three samples shall be tested and examined for conformance to the requirements of 3.4. Water absorption shall be determined in accordance with the following procedure:

4.5.3.2.1 Apparatus.

a. A pan, open top tank, or other vessel of sufficient size containing distilled water maintained at 21°C to 24°C.

b. 150 mm x 150 mm sections of 1/2 inch mesh screen.

c. Appropriate equipment for preparing the specimen.

d. A balance or scales accurate to \pm 0.01 gm with a readability of 0.01 gm.

4.5.3.2.2 Specimens. A specimen shall be a representative piece of the cushioning material 100 mm \pm 2 mm square by 25 mm \pm 2 mm thick. Thinner material shall be stacked to obtain sufficient thickness and shall be stapled near the four corners to hold the specimen together. Thicker specimens shall be cut to the allowable thickness.

4.5.3.2.3 Procedure (submersion technique). Record the weight of the specimen, W_c (conditioned weight) to the nearest 0.01 gm, when at equilibrium with the conditioning environment. Submerge the specimen for 96 hours \pm 1 hour. The specimen should be positioned so that the minimum amount of air will be trapped within the specimen and so that the uppermost surface of the specimen will be submerged 25 mm. At the specified time after contact with the water, remove the specimen on a 150 mm x 150 mm piece of screen. When the specimen has drained for 1 minute, weigh the wet specimen and record the weight, W_s (soaked weight). Express the weight of water absorbed in percent of the weight of the conditioned specimen using the following formula:

$$\frac{W_s - W_c}{W_s} \times 100$$

where:

W_c = the conditioned weight
 W_s = the soaked weight

MIL-PRF-26514G

4.5.3.2.4 Report. Immediately following each test the report (official record) of the facts pertinent to the test shall be completed, and shall include the following:

a. A statement that the test was conducted in compliance with this procedure, or a description of the deviations from this procedure. Report all options selected and details of an otherwise specified procedure that were followed as permitted in 4.5.3.2.2 and 4.5.3.2.3.

b. Identification of the specimen, its nominal dimensions, and the specific material tested.

c. Report the absorption in percent.

d. State that the specimen did or did not meet the requirements and give the source for the requirements.

4.5.3.3 Determination of creep (class 2 only). Three specimens, 150 mm x 150 mm x 75 mm, shall be prepared in accordance with 4.5.1 and preworked in accordance with 4.5.1.3. Three minutes after the last compression, the thickness of each specimen shall be measured with a 175 Pa \pm 35 Pa preload, in accordance with method 1003.2 of FED-STD-101. As an alternative, the thickness may be measured in accordance with 4.5.1.2 to the nearest 0.3 mm and recorded as the original thickness (T_0). For grade A material, the 150 mm x 150 mm face of the test specimen shall be loaded with a 6.4 kg weight to produce a 2.8 KPa static stress. For grade B material, the 150 mm x 150 mm face of the test specimen shall be loaded with an 8.2 kg weight to produce a 3.6 KPa static stress. For grade C material, the 150 mm x 150 mm face of the test specimen shall be loaded with a 14.7 kg weight to produce a 6.4 KPa static stress. For grade D material, the 150 mm x 150 mm face of the test specimen shall be loaded with a 30 kg weight to produce a 13.1 KPa static stress. One hour after continuous loading, the thickness shall be measured and recorded as the initial thickness (t_i) for the determination of creep. The specimens shall remain under constant load, and thickness measurements recorded approximately every 24 hours for a total of four 24-hour increments or until the variation between two successive measurements does not exceed 1 percent of the initial thickness (t_i). The final measurement shall be recorded as t_f . The percentage creep shall be calculated as follows:

$$\text{Percentage of creep} = \frac{(t_i - t_f) \times 100}{t_i}$$

where t_i = initial thickness (loaded)
 t_f = final thickness (loaded)

The creep of the material in a lot shall be the average of the creep of the three specimens (see 3.5).

MIL-PRF-26514G

4.5.3.4 Compression set (class 2 only). Three specimens, 150 mm x 150 mm x 75 mm, shall be prepared in accordance with 4.5.1. The specimens shall be preworked prior to testing. Preworking shall consist of compressing the specimens between parallel, rigid plates 65 percent of their original thickness. Compress a total of 10 times at a rate of 250 mm per minute. Three minutes after the last compression, measure the original thickness, T_0 , in accordance with 4.5.3.3. The specimens shall then be loaded such that they are compressed to and held at 50 percent of their initial thickness for 96 hours. Four hours after the load is removed, the specimen final thickness, T_f , shall be measured in accordance with 4.5.3.3 and the compression set calculated as follows:

$$\text{Compression Set} = \frac{(T_0 - T_f) \times 100}{T_0}$$

where T_0 = initial thickness (unloaded, after preworking)

T_f = final thickness after 4 hours
in unloaded condition

The percent compression set of the material in a lot shall be the average percent compression set of the three specimens. The results shall not exceed the requirements of 3.6.

4.5.3.5 Pliability (class 2 only). The dimension of each specimen shall be 150 mm x 150 mm x 13 mm. The thickness tolerance shall be ± 2 mm. Within two seconds, each of three specimens shall be bent 180 degrees around a cylinder having a 13 mm diameter in a uniform manner such that the foam shall be pressed against the cylinder. The test shall be conducted at room temperature (see 4.5.2) and $-40^\circ\text{C} \pm 1^\circ\text{C}$. For the low temperature test, the specimens shall be conditioned for at least four hours at $-40^\circ\text{C} \pm 1^\circ\text{C}$ and then bent at that temperature or, if not practical, within 5 seconds after removal from the low temperature environment. Each specimen shall be examined for conformance to 3.7.

4.5.3.6 Volume change. Three test specimens, prepared as specified in 4.5.1 and conditioned according to 4.5.2, shall be measured and the volume calculated and recorded. Class 1 specimens shall be 100 mm x 100 mm x 50 mm, aged as specified in 4.5.3.1, and remeasured in accordance with ASTM D 2126. Class 2, grades A, B, and C specimens shall be 200 mm x 200 mm x 75 mm. Class 2, grade D specimens shall be 150 mm x 150 mm x 75 mm. All class 2 specimens shall be subjected to the temperature and humidity conditions only, specified in 4.5.3.1, and remeasured. The volume change of each sample shall be calculated and expressed as a percent of the initial sample volume. The average percent volume change of the sample shall conform to 3.9. Final measurements shall be made immediately following aging.

MIL-PRF-26514G

4.5.3.7 Relative combustibility. The combustibility of the foam shall be determined in accordance with the following subparagraphs. After completion of the test, foam samples shall be examined for conformance to 3.10. A test shall consist of determining the extent of burning of at least five foam samples. Samples shall be cut from sections at least 40 mm from exterior surfaces. The length of each sample shall be perpendicular to the direction of rise.

4.5.3.7.1 Apparatus.

a. Test Chamber. The chamber shall be constructed of heat-resistant material, with controllable ventilation, and shall provide a quite draft-free atmosphere around the specimen. The chamber design shall permit normal thermal circulation of air past the specimen during burning. The minimum inner dimensions shall be 600 mm x 300 mm x 750 mm (L x W x H). A closable opening, for ventilation, approximately 25 mm in diameter, shall be located in the top of the chamber. Use of a hood with an exhaust system, either around the chamber or as the test chamber itself, is strongly recommended in order to remove the noxious products of combustion. Test results should be the same whether or not the chamber damper is closed, the hood fan is off, or both. In cases of discrepancy, values obtained with the damper closed or the hood fan off, or both, shall be the validtest results. The chamber/hood shall have a heat-resistant viewing window of sufficient size, and located such that the entire specimen being tested can be observed. The chamber should be easily opened and closed to facilitate test activities. The test organization's operations and equipment shall be approved by the appropriate environmental and/or safety activity.

b. Burner. A standard Bunsen or Tirrill burner (10 mm outside diameter barrel) fitted with a 50 mm wide wing top shall be used. The wing top may have to be opened to approximately 3 mm to provide the flame as required in figure 7. Use flexible metal hose or adequately protected rubber or plastic hose.

c. Fuel Supply. Propane gas of at least 85 percent purity shall be used.

d. Specimen Support. Wire cloth (wire screen) with a minimum 5 mm mesh using a maximum 1 mm diameter steel wire. The wire cloth specimen support 75 mm x 200 mm shall have a 15 mm of length bent to form a right angle. This will form the specimen support as shown in figure 6.

e. Specimen Support Holder. Any holding device that will clamp the wire cloth specimen support horizontally so that the bottom of the bent-up portion is 15 mm above the top of the burner wing top, as shown in figure 6. A typical arrangement consists of two laboratory ring stands with two adjustable flat-surface clamps which may be locked in place with set screws and lock nuts.

MIL-PRF-26514G

f. Timing Device. Readable to ± 1 second.

4.5.3.7.2 Test specimens.

a. Five specimens 50 mm \pm 2 mm wide and 150 mm \pm 2 mm long are needed.

b. Material thickness shall be 10 mm \pm 2 mm.

c. Each test specimen shall be marked across its width by one line 125 mm from one end.

4.5.3.7.3 Conditioning. Specimens shall be conditioned prior to test for a minimum of 24 hours in an atmosphere having a temperature of 23 C \pm 1°C and a relative humidity of 50 percent RH \pm 5 percent RH. Tests shall be made in this atmosphere or immediately after removal therefrom.

4.5.3.7.4 Procedure. See figures 6, 7, and 8.

a. Clamp the wire cloth specimen support horizontally so that the bottom of the wire cloth is 15 mm above the top of the burner wing top as shown in figure 6. Place a layer of aluminum foil on the bottom of the test chamber to catch any dripping or flaming particles. Change the foil after each test if there is any debris on the surface from the previous determination. Burn off any material remaining on the wire cloth from the previous tests, or use a new wire cloth for each test. If a new wire cloth is not used for each test, the wire cloth should be cool to the touch before being used. If dripping or melting material falls into the wing top, clean it before testing the next specimen.

b. Place the specimen on the support with one end touching the 15 mm bent-up portion of the support. The end of the specimen nearest the gage mark should be away from the bent-up end of the specimen support, so that the gage mark is 125 mm away from the bent-up end.

c. Adjust the burner with the wing top to provide a blue flame whose visible portion is 40 mm high with a clearly defined inner cone 5 mm high. Place the burner under the upturned end of the specimen support so that one edge of the flame is in line with the upturned end of the wire cloth and the other edge of the flame extends into the front end of the specimen.

d. Start the timing device when the flame is first applied to the specimen. After 60 seconds, move the burner at least 150 mm away from the test specimen. If the flame goes out before reaching the gage mark, the extent of burning is equal to 125 mm minus the distance from the gage mark to the nearest evidence of the flame front (such as charring along the upper surface of the specimen), measured to the nearest 2 mm. Note burning

MIL-PRF-26514G

characteristics, such as expansion, as a result of heating, melting, or dripping. Also record if the drippings on the foil burn. In some cases, the burning may cease in the first 60 seconds. This is evident by the disappearance of the yellow or characteristic flame.

4.5.3.7.5 Calculations.

a. If the flame front passes the gage mark on any one of the five specimens, the lot has failed.

b. If the flame front does not reach the gage mark for all five specimens, average the distance burned in millimeters as measured on the top surface.

4.5.3.7.6 Report. The report shall include the following:

a. The description of the material, including the proprietary designation and complete description per this specification.

b. A description of samples that burned to gage mark.

EXAMPLE: (150 mm sample was consumed completely).

c. Record burning characteristics, such as dripping.

d. For samples that did not burn to the gage mark, report the average extent of burning. (125 mm minus the distance between the gage mark and closest evidence of burning.)

4.5.3.7.7 Precision. The standard deviation for inter-laboratory reproducibility is 10 mm.

4.5.3.8 Compressive strength (class 1 only). The compressive strength shall be determined in accordance with ASTM D 1621, Procedure A, and examined for conformance to 3.11. After a 72-hour cure time, five specimens 100 mm x 100 mm x 50 mm shall be prepared from each of three 400 mm x 400 mm x 400 mm single-pour blocks of foam such that the depth dimension of 50 mm is parallel to the direction of foam rise. These specimens shall then be tested for compressive strength values at yield or 10 percent deflection, whichever occurs first. Additionally, five specimens 100 mm x 100 mm x 50 mm shall be cut from each of the same three sample blocks such that the depth dimension of 50 mm is perpendicular to the direction of foam rise, then tested as with the initial fifteen specimens. Failure of the average compressive strength value, recorded for each set of five specimens, to conform to the requirement of 3.11 shall be cause for rejection.

4.5.3.9 Dynamic cushioning properties (class 2 only).

MIL-PRF-26514G

4.5.3.9.1 Peak acceleration versus static stress data. The data to plot the peak acceleration in Gs (multiples of acceleration due to gravity (g)) versus static stress in Pascals from a drop height of 0.6 m shall be established in accordance with ASTM D 1596 with exceptions specified herein.

4.5.3.9.2 Specimens. For class 2, grades A, B, and C, three specimens shall be prepared 200 mm x 200 mm x 75 mm \pm 2 mm. For class 2, grade D, three specimens shall be prepared 150 mm x 150 mm x 75 mm \pm 2 mm. All class 2 specimens shall be prepared in accordance with 4.5.1 with thickness determined in accordance with 4.5.1.2.

4.5.3.9.3 Preworking. Each specimen shall be preworked in accordance with 4.5.1.3, compressing them 65 % of their original thickness. Specimens shall be rested for at least 16 but not more than 72 hours before conducting the dynamic test procedure.

4.5.3.9.4 Dynamic test procedure. All test samples shall be measured to determine that samples are within 10 percent of the required thickness of 75 mm before starting the dynamic test procedure. Impact tests shall be conducted on each specimen so that the dropping head compresses the specimen at an initial velocity of 3.43 m \pm 0.05 m per second. This corresponds to a nominal initial free-fall drop height of 0.6 m. The acceleration-time record of the dropping head during compression of the cushion shall be recorded for each drop. With the dropping head at the lowest static stress point, five consecutive drops shall be made on each of the specimens comprising the sample material. At least one minute shall elapse between drops to permit the specimen to regain its shape. A quantity of weight shall then be added to the dropping head to obtain the next required higher static stress point and the drop test procedure repeated on the same cushions. This procedure shall be repeated until the qualifying test values have been obtained. No material samples will be replaced during the test for any reason. If any of the cushions are degraded to a point where they can no longer be impacted, the whole lot shall be rejected.

4.5.3.9.5 Computations. The first reading obtained from each set of drops shall be discarded and the peak acceleration readings of the remaining 4 drops shall be averaged. The average values, one for each specimen, shall then be averaged to obtain one value at each static stress point for the sample. The required peak G-static stress points shall be examined for conformance to 3.12.

4.5.3.10 Anti-static property test (type III only). Specimens shall be tested for conformance to the requirements of 3.13. Static decay time shall be determined in accordance with FED-STD-101, Method 4046.1, with the following exceptions:

MIL-PRF-26514G

a. Three specimens shall be 75 mm x 125 mm with a thickness of 10 mm or 10 mm plus 2 mm and minus 0.0 mm.

b. Prior to testing, specimens shall be conditioned in an atmosphere uniformly maintained at $23^{\circ}\text{C} \pm 1^{\circ}\text{C}$ and a relative humidity of 12 percent RH \pm 3 percent RH, for 24 hours.

c. Each specimen, when tested, shall be mounted vertically between the electrodes, and the wing nuts shall be tightened in such a manner as to ensure intimate contact with the electrode surfaces without causing visible distortion or compression of the specimen.

d. The charging cycles shall be terminated after the specimen's charge has decayed to the 50 volt level.

4.5.3.11 Corrosivity test (type III only). Anti-static cushioning material specimens shall be tested in accordance with method 3005 of FED-STD-101. Two test surfaces shall be exposed for 72 hours and shall be:

a. QQ-A-225/6 aluminum alloy 2024, temper T6.

b. ANSI/IPC-MF-150 copper foil, rolled, nominal weight 10 oz/ft, nominal thickness 0.014 inches.

Test surfaces shall not be ground or abraded, but otherwise shall be prepared according to 3.8.2 of FED-STD-101. After the exposure period, the presence of corrosion as defined in 2.1 of FED-STD-101 shall be cause for rejection. Two suppliers of the above mentioned metals are Metaspec Company, PO Box 27707, San Antonio, TX 78227 and Pacific Sensors, Inc., 11303 Slater Ave., Fountain Valley, CA 92708.

5. PACKAGING

5.1 Packaging. For acquisition purposes, the packaging requirements shall be specified in the contract or order (see 6.2). When actual packaging of material is to be performed by DoD personnel, these personnel need to contact the responsible packaging activity to ascertain requisite packaging requirements. Packaging requirements are maintained by the Inventory Control Point's packaging activity within the Military Department, Defense Agency or within the Military Department's System Command. Packaging data retrieval is available from the managing Military Department's or Defense Agency's automated packaging files, CD-ROM products, or by contacting the responsible packaging activity.

6. NOTES

(This section contains information of a general or explanatory nature that may be helpful but is not mandatory.)

MIL-PRF-26514G

6.1 Intended use. Materials covered by this specification are intended for use as cushioning and blocking/bracing in packages to protect equipment and items therein from damage by shock or impact incurred during shipment and handling.

6.2 Acquisition requirements. Acquisition documents must specify the following:

- a. Title, number, and date of this specification.
- b. Issue of DODISS to be cited in the solicitation and, if required, the specific issue of individual documents referenced (see 2.1).
- c. Type, class, and grade (see 1.2).
- d. Form required (rolls, sheets, etc.) (see 3.2).
- e. Hydrolytic stability - state if not required (see 3.3 and 6.5).
- f. Maximum allowable percentage creep, if other than as specified in 3.5 (class 2).
- g. Maximum allowable percentage compression set, if other than as specified in 3.6 (class 2).
- h. Pliability (class 2) - state if not required (see 3.7).
- i. Dimensions (see 3.8).
- j. Minimum compressive strength, if other than as specified in 3.11 (class 1).
- k. Color coding (class 2 only) (see 3.14).
- l. Indicate whether first article inspection is required/waived (see 3.1 and 4.3.1).
- m. Packaging requirements (see 5.1).
- n. Ether or ester (class 2 only) (see 6.5).
- o. Quantity.
- p. After 1 Oct 93, provide certified statement that the product does not contain CFCs.

6.3 First article. When first article inspection is required, the contracting officer should provide specific guidance to offerors whether the item(s) should be a preproduction sample, a first article sample, a first production item, a sample selected from the first production items, a standard production item from the contractor's current inventory (see 3.1), and the number of items to be tested as specified in 4.3.2. The contracting

MIL-PRF-26514G

officer should also include specific instructions in acquisition documents regarding arrangements for examinations, approval of first article test results, and disposition of first articles. Invitations for bid should provide that the Government reserves the right to waive the requirement for samples for first article inspection to those bidders offering a product which has been previously acquired or tested by the Government and that bidders offering such products, who wish to rely on such production or test, must furnish evidence with the bid that prior Government approval is presently appropriate for the pending contract. Bidders should not submit alternate bids unless specifically requested to do so in the solicitation.

6.4 Sampling Procedures. Samples shall be selected as listed below and subjected to the tests described in 4.5. Specimen size and preparation shall be in accordance with 4.5.1.

a. Rolls: A sample roll shall be selected at random from the lot. Specimens of sufficient size to conduct the tests shall be taken from the sample after removal of two thicknesses of material from the roll.

b. Sheets: Three bundles shall be selected, the top three sheets of each bundle removed, and samples taken at random from the remainder of each bundle.

c. Die-cut pads: Three samples of sufficient size for testing shall be selected from the sheet stock from which the pads are fabricated.

d. Molded shapes: Three rectangular blocks of sufficient size and molded in a similar fashion as the molded shapes shall be used to conduct the specified tests.

e. Machine shapes: Three samples of sufficient size to conduct the specified tests shall be selected and cut from the base stock.

6.5 Hydrolytic stability. Some polyurethane foams, esters in particular, will not pass this test but satisfactorily meet all other requirements and, in some instances, have dynamic cushioning properties superior to other formulations. Procuring activities may waive the hydrolytic stability requirements.

6.6 Compressive strength (class 1 only). The compressive strength requirements of 3.11 were developed from test data obtained on materials with nominal densities of 32 kg/m³. If a different density material is specified, the compressive strengths should also be specified.

6.7 Dynamic cushioning data. The requirements of 3.12 are intended to ensure procurement of a consistently uniform product of a quality attainable by most of the industry. The values presented in 3.12 should be considered as quality assurance

MIL-PRF-26514G

requirements only, not as design criteria. For design purposes, complete cushioning data in the form of peak acceleration versus static stress curves can be obtained from other sources, such as MIL-HDBK-304. The color coding is used by military field activities to identify the grade of material.

6.8 Cross-classification. This revision to MIL-P-26514 deletes type II (foam-in-place) material. Refer to MIL-F-83671 for materials previously classified as MIL-P-26514, type II.

6.9 Approval of dynamic compression testing apparatus. Information regarding dynamic compression testing apparatus can be obtained by contacting AFMC LSO/LOP, 5215 Thurlow St., Wright-Patterson AFB, OH 45433-5540.

6.10 Subject term (key word) listing.

- Packaging materials
- Polyurethane foam
- Cushioning
- Antistatic foam
- Rigid foam
- Flexible foam

6.11 Changes from previous issue. Marginal notations are not used in this revision to identify changes with respect to the previous issue due to the extent of the changes.

MIL-PRF-26514G

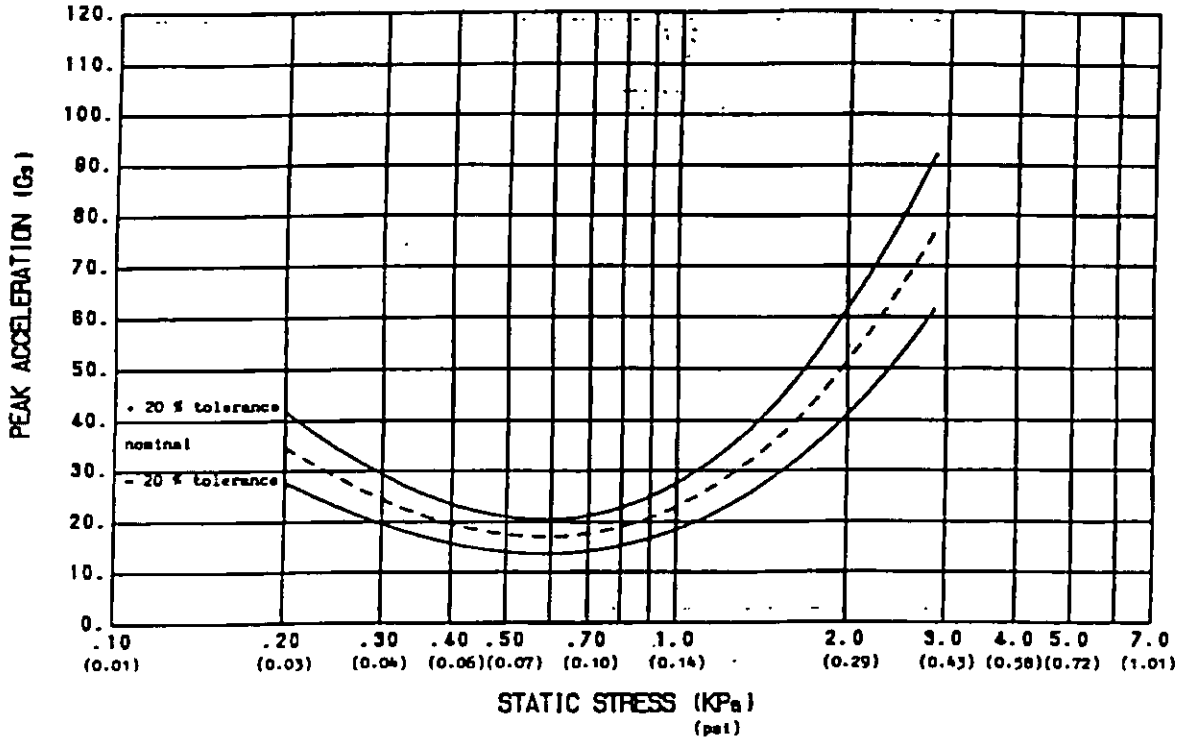

Peak C - Static Stress Curve
drop height 0.6 m
sample size 200 mm x 200 mm x 75 mm
(see 6.7)

FIGURE 1. Class 2, grade A.

MIL-PRF-26514G

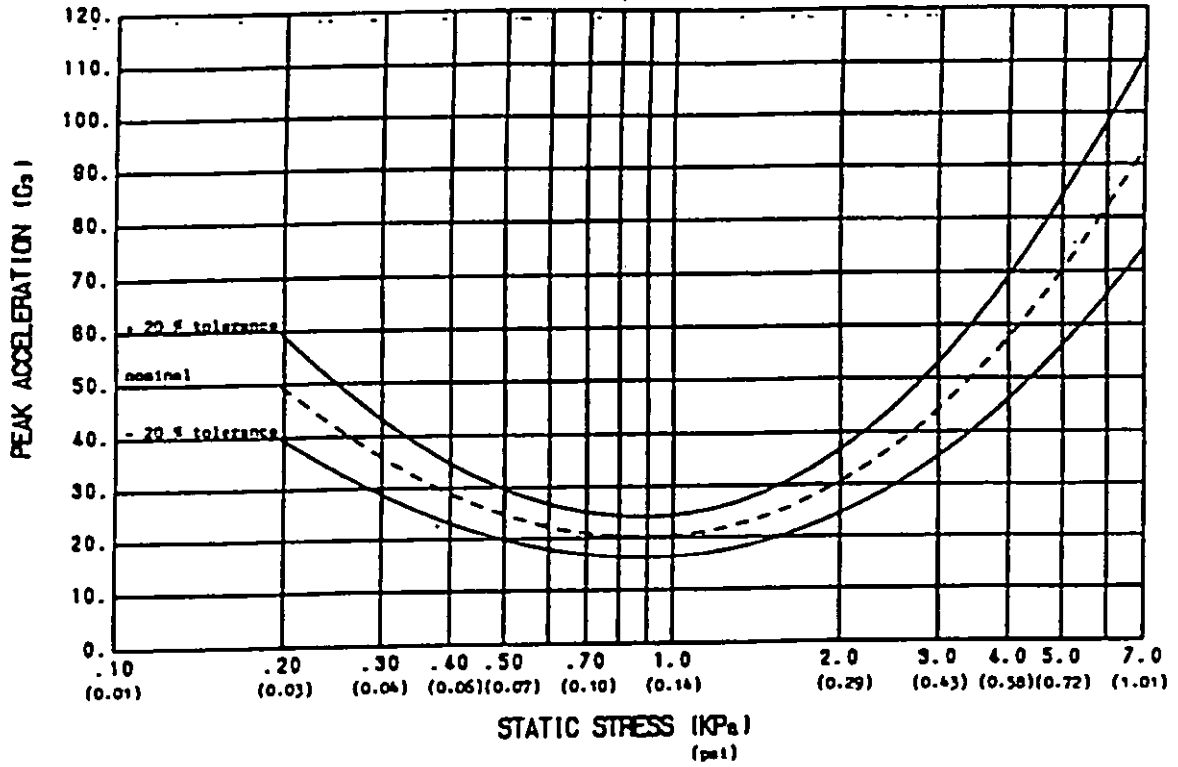

Peak G - Static Stress Curve
 drop height 0.6 m
 sample size 200 mm x 200 mm x 75 mm
 (see 6.7)

FIGURE 2. Class 2, grade B.

MIL-PRF-26514G

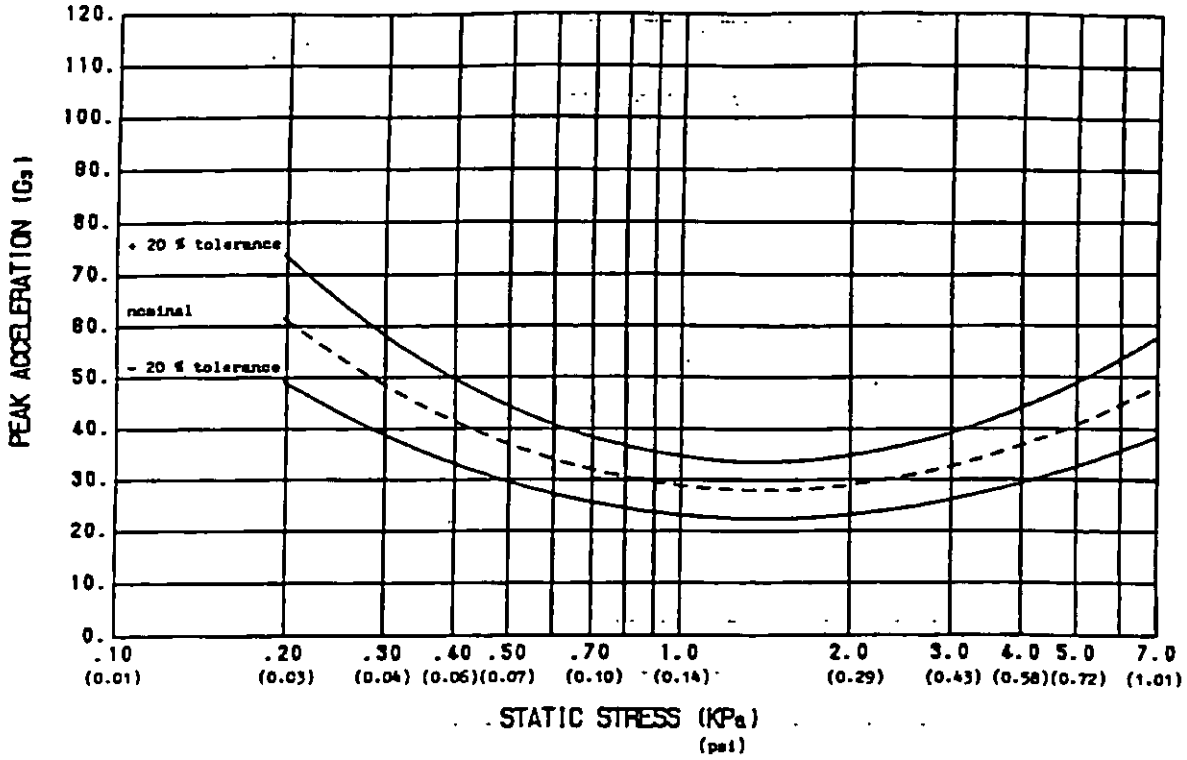

Peak G - Static Stress Curve
 drop height 0.6 m
 sample size 200 mm x 200 mm x 75 mm
 (see 6.7)

FIGURE 3. Class 2, grade C.

MIL-PRF-26514G

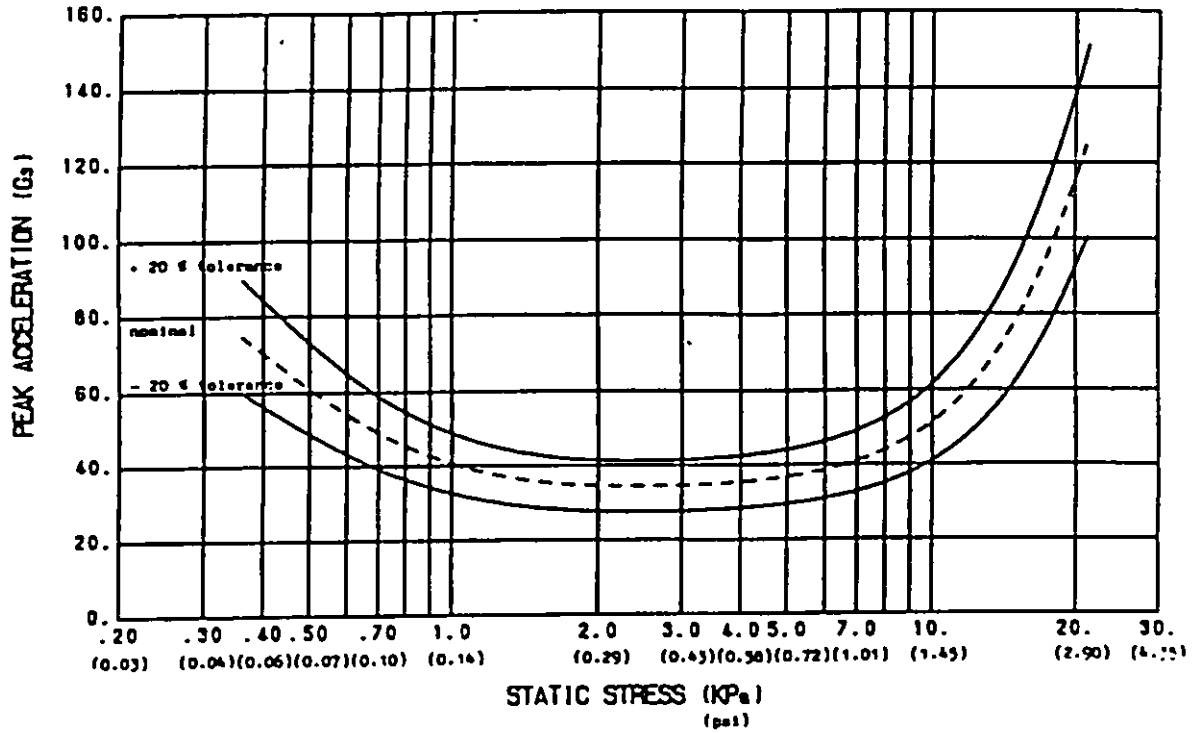

Peak C - Static Stress Curve
drop height 0.6 m
sample size 150 mm x 150 mm x 75 mm
(see 6.7)

FIGURE 4. Class 2, grade D.

MIL-PRF-26514G

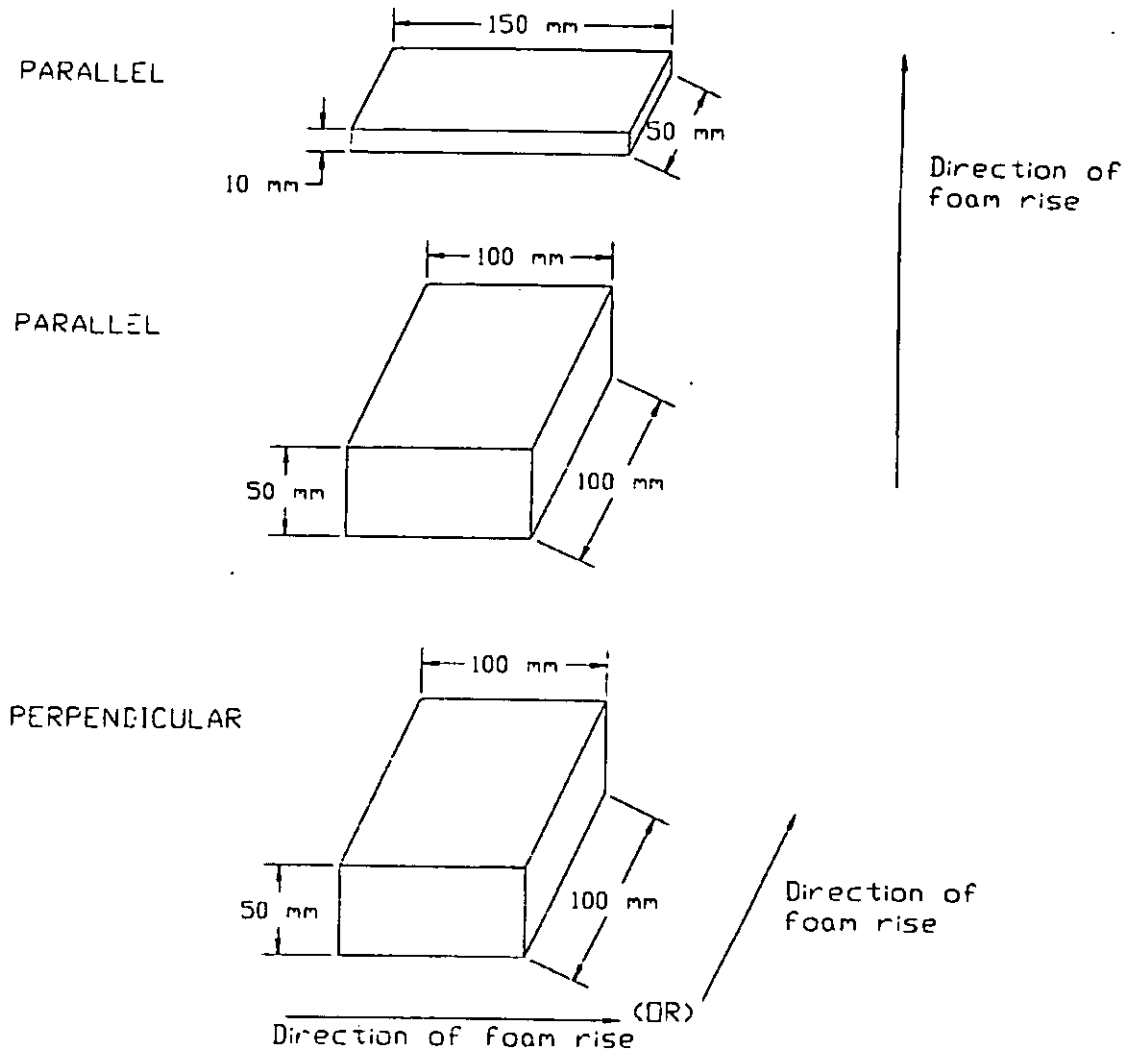

FIGURE 5. Example of orientation of foam samples.

MIL-PRF-26514G

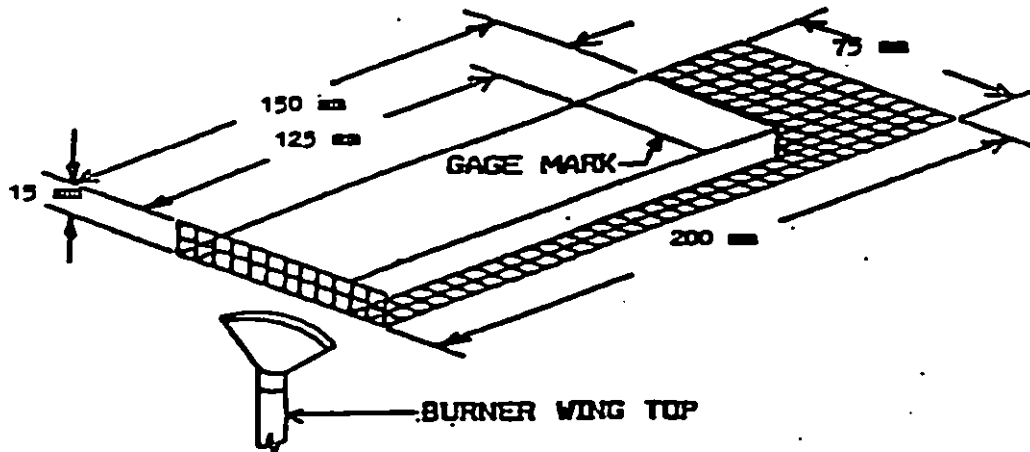

FIGURE 6. Relative positions of burner wing top, specimen, and specimen support.

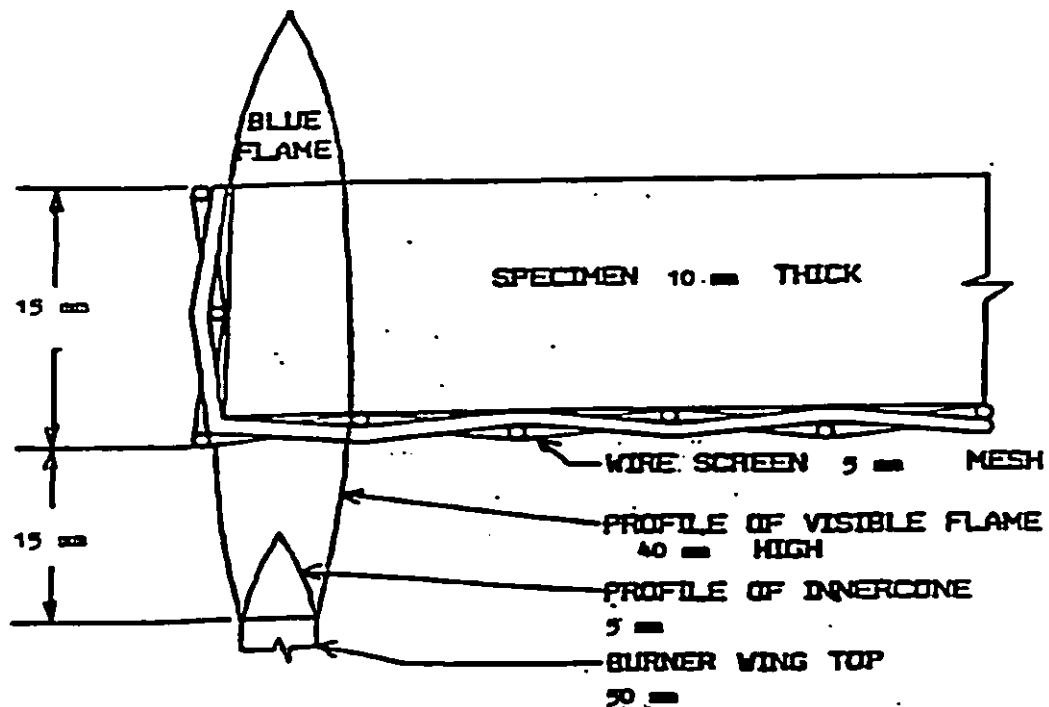

FIGURE 7. Relative positions of burner wing top, flame, specimen, and specimen support.

MIL-PRF-26514G

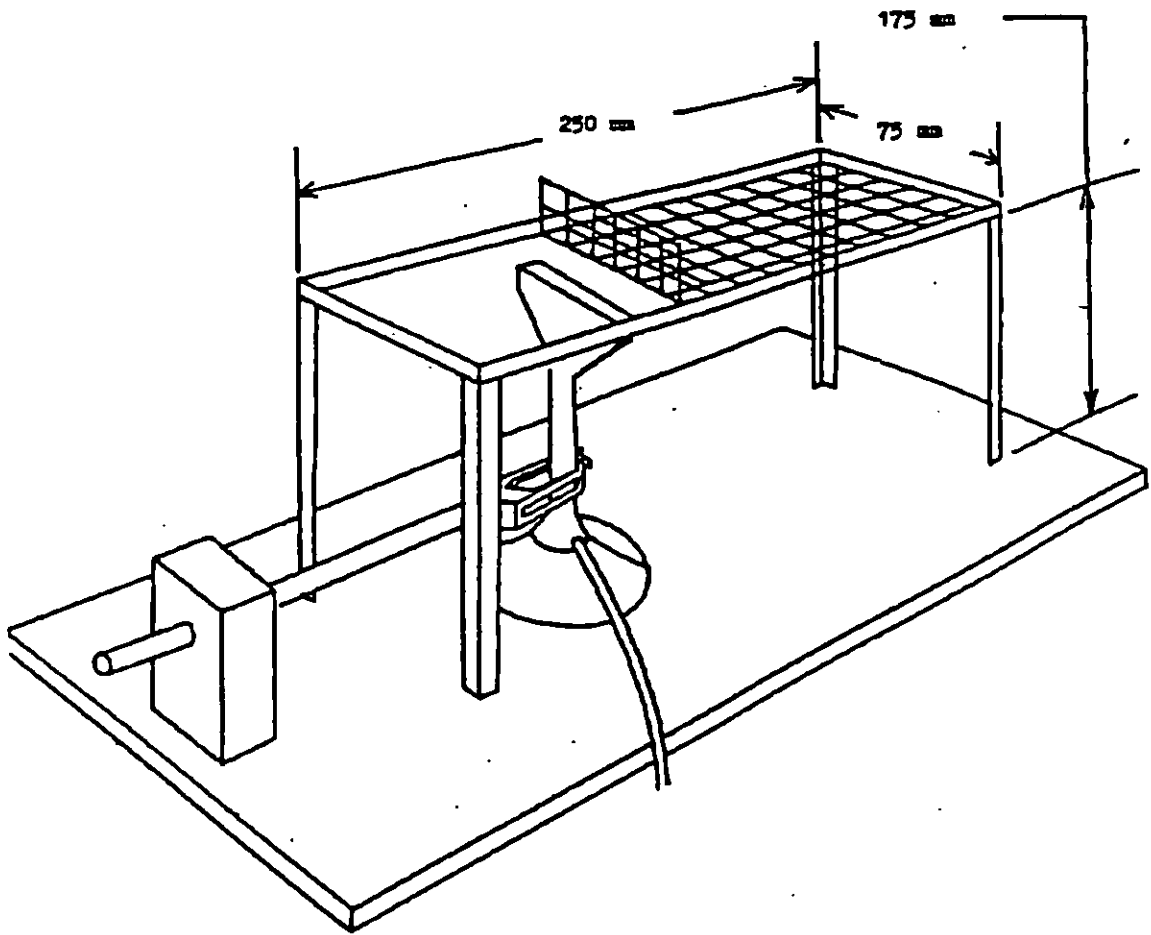

FIGURE 8. Apparatus for support of specimen.

MIL-PRF-26514G

Custodians:

Army - GL
Navy - AS
Air Force - 69

Preparing Activity:

Air Force - 69

Review activities:

Army - AR, AT, AV
Navy - EC, MC, OS, SH, SA, YD
Air Force - 99, 71, 80, 84

(Project 8135-0680)

Other Activities:

AIA
NDPA
NSIA

STANDARDIZATION DOCUMENT IMPROVEMENT PROPOSAL

INSTRUCTIONS

1. The preparing activity must complete blocks 1, 2, 3, and 8. In block 1, both the document number and revision letter should be given.
2. The submitter of this form must complete blocks 4, 5, 6, and 7.
3. The preparing activity must provide a reply within 30 days from receipt of the form.

NOTE: This form may not be used to request copies of documents, nor to request waivers, or clarification of requirements on current contracts. Comments submitted on this form do not constitute or imply authorization to waive any portion of the referenced document(s) or to amend contractual requirements.

I RECOMMEND A CHANGE:	1. DOCUMENT NUMBER MIL-PRF-26514G	2. DOCUMENT DATE (YYMMDD) 95 Aug 01
3. DOCUMENT TITLE Polyurethane Foam, Rigid or Flexible, For Packaging		
4. NATURE OF CHANGE (Identify paragraph number and include proposed rewrite, if possible. Attach extra sheets as needed.)		
5. REASON FOR RECOMMENDATION		
6. SUBMITTER		
a. NAME (Last, First, Middle Initial)	b. ORGANIZATION	
c. ADDRESS (Include Zip Code)	d. TELEPHONE (Include Area Code) (1) Commercial (2) AUTOVON (If applicable)	e. DATE SUBMITTED (YYMMDD)
8. PREPARING ACTIVITY		
a. NAME	b. TELEPHONE (Include Area Code) (1) Commercial (2) AUTOVON	
c. ADDRESS (Include Zip Code)	IF YOU DO NOT RECEIVE A REPLY WITHIN 45 DAYS, CONTACT: Defense Quality and Standardization Office 5203 Leesburg Pike, Suite 1403, Falls Church, VA 22041-3466 Telephone (703) 756-2340 AUTOVON 289-2340	