

INCH-POUND

**MIL-PRF-5606H
w/Amendment 2
27 October 2005
SUPERSEDING
MIL-PRF-5606H
w/Amendment 1
23 July 2003**

**PERFORMANCE SPECIFICATION
HYDRAULIC FLUID, PETROLEUM BASE;
AIRCRAFT, MISSILE, AND ORDNANCE**

Inactive for new design after 29 March 1996. For new designs, use MIL-PRF-87257 or MIL-PRF-83282.

This specification is approved for use by all Departments and Agencies of the Department of Defense.

1. SCOPE

1.1 Scope

This specification describes the characteristics and provides the requirements for a petroleum base hydraulic fluid for use in the -54°C to +135°C temperature range (see 6.1). This fluid is identified by military symbol OHA and NATO Code No. H-515 (see 6.5).

2. APPLICABLE DOCUMENTS

2.1 Government documents

2.1.1 Specifications and standards

The following specifications and standards form a part of this specification to the extent specified herein. Unless otherwise specified, the applicable issue (revision) of each document is that listed in the issue of the *Department of Defense Index of Specifications and Standards (DoDISS)*, and supplement thereto, cited in the solicitation (see 6.2).

Comments, suggestions, or questions on this document should be addressed to ASC/ENOI, 2530 Loop Road West, Wright-Patterson AFB OH 45433-7101 or emailed to EngineeringStandards@wpafb.af.mil. Since contact information can change, you may want to verify the currency of this address information using the ASSIST Online database at <http://assist.daps.dla.mil>.

AMSC N/A

FSC 9150

DISTRIBUTION STATEMENT A. Approved for public release; distribution is unlimited.

SPECIFICATIONS

FEDERAL

TT-T-656 Tricresyl Phosphate

STANDARDS

FEDERAL

FED-STD-791 Lubricants, Liquid Fuels, and Related Products; Methods of Testing

(Unless otherwise indicated, copies of federal and military specifications, standards, and handbooks are available from the Department of Defense Single Stock Point, Standardization Documents Order Desk, Bldg. 4D, 700 Robbins Avenue, Philadelphia PA 19111-5094. Access via ASSIST online at [http://astimage.daps.dla.mil/online/new/.](http://astimage.daps.dla.mil/online/new/))

2.2 Non-Government publications

The following documents form a part of this document to the extent specified herein. Unless otherwise specified, the applicable issue (revision) of each DoD-adopted document is that listed in the issue of the *DoD/ISS* cited in the solicitation. Unless otherwise specified, the applicable issue of each non DoD-adopted document is the issue of the document cited in the solicitation (see 6.2).

AMERICAN SOCIETY FOR TESTING AND MATERIALS (ASTM)

ASTM D 93	Standard Test Method for Flash Point by Pensky-Martens Closed Tester (DoD adopted)
ASTM D 97	Standard Test Method for Pour Point of Petroleum Oils (DoD adopted)
ASTM D 130	Standard Method for Detection of Copper Corrosion from Petroleum Products by the Copper Strip Tarnish Test (DoD adopted)
ASTM D 287	Standard Test Method for API Gravity of Crude Petroleum and Petroleum Products (Hydrometer Method) (DoD adopted)
ASTM F 312	Standard Methods for Microscopical Sizing and Counting Particles from Aerospace Fluids on Membrane Filters
ASTM D 445	Standard Test Method for Kinematic Viscosity of Transparent and Opaque Liquids (and the Calculation of Dynamic Viscosity) (DoD adopted)
ASTM D 664	Standard Test Method for Acid Number of Petroleum Products (DoD adopted)
ASTM D 892	Standard Test Method for Foaming Characteristics of Lubricating Oils (DoD adopted)
ASTM D 972	Standard Test Method for Evaporation Loss of Lubricating Greases and Oils (DoD adopted)
ASTM D 1500	Standard Test Method for ASTM Color of Petroleum Products (ASTM Color Scale) (DoD adopted)

MIL-PRF-5606H

ASTM D 2603	Test Method for Sonic Shear Stability of Polymer-Containing Oils (DoD adopted)
ASTM D 4057	Standard Practice for Manual Sampling of Petroleum and Petroleum Products
ASTM D 4172	Standard Test Method for Wear Preventive Characteristics of Lubricating Fluid (Four-Ball Method) (DoD adopted)
ASTM D 4177	Standard Practice for Automatic Sampling of Petroleum and Petroleum Products (DoD adopted)
ASTM D 4636	Standard Test Method for Corrosiveness and Oxidation Stability of Hydraulic Oils, Aircraft Turbine Engine Lubricants, and Other Highly Refined Oils (DoD adopted)
ASTM D 4898	Standard Test for Insoluble Contamination of Hydraulic Fluids by Gravimetric Analysis (DoD adopted)
ASTM D 5185	Standard Test Method for Determination of Additive Elements, Wear Metals, and Contaminants in Used Lubricating Oils and Determination of Selected Elements in Base Oils by Inductively Coupled Plasma Atomic Emission Spectrometry (ICP-AES) (DoD adopted)
ASTM D 5949	Standard Test Method for Pour Point of Petroleum Products (Automatic Pressure Pulsing Method)
ASTM D 6304	Standard Test Method for Determination of Water in Petroleum Products, Lubricating Oils, and Additives by Coulometric Karl Fisher Titration

(Application for copies should be addressed to ASTM International, 100 Barr Harbor Drive, PO Box C700, West Conshohocken, Pennsylvania, USA 19428-2959. Order online at www.astm.org.)

AMERICAN SOCIETY FOR QUALITY CONTROL

ASQ Z1.4	Sampling Procedures and Tables for Inspection by Attributes (DoD adopted)
----------	---

(Application for copies should be addressed to American Society for Quality Control, 611 East Wisconsin Avenue, Milwaukee, WI 53202. Order online at <http://www.ASQ.org>.)

SOCIETY OF AUTOMOTIVE ENGINEERS (SAE)

SAE AMS 3217/2	Test Slabs, Acrylonitrile Butadiene (NBR-L), Low Acrylonitrile, 65 - 75 (DoD adopted)
----------------	---

(Application for copies should be addressed to SAE, Inc., 400 Commonwealth Drive, Warrendale, PA 15096-0001. Order online at <http://www.sae.org>.)

(Non-Government standards and other publications are normally available from the organizations that prepare or distribute the documents. These documents also may be available in or through libraries or other informational services.)

2.3 Order of precedence

In the event of a conflict between the text of this document and the references cited herein, the text of this document takes precedence. Nothing in this document, however, supersedes applicable laws and regulation unless a specific exemption has been obtained.

3. REQUIREMENTS

3.1 Qualification

The hydraulic fluid furnished under this specification shall be products which are authorized by the qualifying activity for listing on the applicable Qualified Products List (QPL) at the time of award of contract (see 4.2 and 6.3). Changes shall not be permitted in the formulation of an approved product unless specific, written approval of the qualifying activity is obtained.

3.2 Materials

The fluid shall consist of petroleum products with additive materials to improve the low-temperature flow and viscosity-temperature characteristics, resistance to oxidation, and anti-wear properties of the finished product. A red dye shall be used for coloring.

3.2.1 Additives

There shall be no restriction on the types of materials used as additives in the fluid except for those specified in sections 3 and 4 and those imposed by technical requirements of this specification. Pour point depressants may be used.

3.2.2 Viscosity/temperature coefficient improvers

Polymeric materials may be added to the base petroleum oil in quantities not greater than 20 percent by weight of active ingredient in order to adjust the viscosity of the finished fluid to the values specified in 3.4.

3.2.3 Oxidation inhibitors

Oxidation inhibitors shall be added to the base oil in quantities not greater than 2 percent by weight.

3.2.4 Anti-wear agent

The hydraulic fluid shall contain not greater than 3 percent of weight of an anti-wear agent, such as tricresyl phosphate, that conforms to *TT-T-656*, or equivalent. When tricresyl phosphate is used, it shall contain not greater than 1 percent of the ortho-isomer.

3.2.5 Red dye

The fluid shall contain red dye in a concentration not greater than 1 part of dye per 10,000 parts of oil by weight.

MIL-PRF-5606H

3.3 Properties of petroleum base stock

The properties of the petroleum base stock used in formulating the finished fluid shall be as designated in *table I* when tested as specified in 4.4.3.

TABLE I. Properties of petroleum base stock.

Property	Test Limits
Pour point, °C (max)	-60
Flash point, °C (min)	82
Acid number (max)	0.10
Color, ASTM standard (max)	No. 1
Specific gravity at 15.6°C/15.6°C (60.0°F/60.0°F)	Report ¹

¹ Samples of base stock submitted for acceptance tests shall not vary by more than ± 0.008 from the specific gravity of the original sample submitted for qualification tests.

3.4 Properties of finished fluid

The properties of the finished fluid shall be as specified in *table II*, 3.5, and 3.6 when tested as specified in 4.4.3.

MIL-PRF-5606H

TABLE II. Properties of finished fluid.

Property	Test Limits	Reference
Acid number, mg KOH/g (max)	0.20	4.4.3
Barium content, parts per million (max)	10	4.4.3
Copper strip corrosion, ASTM standard (max)	No. 2e	4.4.3
Corrosiveness and oxidation stability (168 hrs at 135 ± 1°C)		4.4.3
Change in acid number (max)	0.20	
Metal specimen weight change, mg/cm ² (max) ⁽¹⁾		
Aluminum	±0.2	
Cadmium plated steel ⁽²⁾	±0.2	
Copper ⁽³⁾	±0.6	
M-50 Steel	±0.2	
Magnesium	±0.2	
Percent change in viscosity at 40°C	-5 to +20	
Separation of insoluble materials or gumming of the fluid	None	
Evaporation loss, percent (max)	20	4.4.3
Flash point, °C (min)	82	4.4.3
Foaming characteristics @ 24°C		4.4.3
Foaming tendency, ml (max) (volume at end of five-minute blowing period)	65	
Foam stability, ml (max) (volume at end of ten-minute settling period)	Complete Collapse ⁽⁴⁾	
Isothermal secant bulk modulus @ 40°C and 27.6 MPa (4000 psig), MPa (psi) (min)	1379 (200,000)	4.4.3.5 & Appendix A
Low temperature stability	See 3.5.2	4.4.3
Pour point, °C (max)	-60	4.4.3
Rubber swell, standard synthetic rubber L, percent	19.0 to 30.0	4.4.3
Solid particle contamination		4.4.3
Filtration time @ 25°C ± 5°C, minutes (max)	15	
Particle count	See <i>table III</i>	
Gravimetric analysis, mg/100 ml (max)	0.3	
Steel-on-steel wear (average wear scar), mm in diameter (max)	1.0	4.4.3
Viscosity in centistokes at -54°C (max)	2500	4.4.3
Viscosity in centistokes at -40°C (max)	600	4.4.3
Viscosity in centistokes at 40°C (min)	13.2	4.4.3
Viscosity in centistokes at 100°C (min)	4.90	4.4.3
Water, parts per million total (max)	100	4.4.3

(1) There shall be no pitting, etching, or visible corrosion on the surface of the metals when viewed under magnification of 20 diameters.

(2) A slight discoloration is permitted.

(3) Any corrosion (discoloration) produced on the surface of the copper shall be not greater than No. 3 of the *ASTM D 130* copper corrosion standard.

(4) A ring of small bubbles around the edge of the graduate shall be considered complete collapse.

MIL-PRF-5606H

TABLE III. Solid particle contamination.

Particle Size Range (largest dimension) micrometers	Allowable Number (max) each determination automatic count
5-15	10,000
15-25	1,000
25-50	150
50-100	20
Over 100	5

3.5 Performance

3.5.1 Corrosiveness and oxidation stability

When tested as specified in 4.4.3, the requirements presented in *table II* shall be met.

3.5.2 Low temperature stability

When tested as specified in 4.4.3 for 72 hours at a temperature of $-54^{\circ}\text{C} \pm 1^{\circ}\text{C}$, the fluid shall show no evidence of gelling, crystallization, solidification, or separation of ingredients.

3.5.3 Shear stability

When tested as specified in 4.4.3, the percent viscosity decrease of the hydraulic fluid, measured in centistokes at 40°C , shall be not greater than the percentage viscosity decrease of the shear stability reference fluid. The increase in acid number shall be not greater than 0.20 over the original acid number.

3.5.4 Storage stability

The fully blended product shall show no separation of ingredients or evidence of crystallization. The fully blended product shall be clear and transparent when examined visually, and shall conform to the requirements of section 3 after 12 months of storage as specified in 4.4.3.

3.5.5 Color

There shall be no readily discernible difference in the color of the finished fluid compared to the standard color when tested as specified in 4.4.3.

3.5.6 Toxicity

The hydraulic fluid shall have no adverse effect on the health of personnel when used for its intended purpose. The fluid shall contain no components that produce noxious vapors in such concentrations as to be an irritant to personnel during formulation or use under conditions of adequate ventilation. Exercise caution to avoid prolonged contact with the skin and observe Occupational Safety and Health Administration (OSHA) guidelines. Questions pertaining to the toxic effects shall be referred to the appropriate

departmental medical service who will act as an advisor to the procuring activity (see 4.2).

3.6 Workmanship

The workmanship shall be in accordance with high-grade, commercial practices covering this type of material. The finished fluid shall be homogeneous and free from suspended matter, grit, or other adulteration.

4. VERIFICATIONS

4.1 Classification of inspections

The examination and testing of the hydraulic fluid shall be classified as follows:

- a. Qualification inspection (see 4.2)
- b. Conformance inspection (see 4.3)

4.2 Qualification inspection

4.2.1 Qualification sample

Qualification samples shall consist of a 1-gallon container of hydraulic fluid. The following may also be requested at the option of the qualifying activity: 1 quart petroleum-base stock before the addition of additive agents, 1 gram red dye, 4 ounces of the additive used to improve the viscosity-temperature coefficient, 4 ounces anti-wear agent, 2 ounces pour depressant (if used), 1 ounce of the compound used to improve the oxidation stability, and 1 ounce of any other additive used in the formulation. In the event additives are supplied as concentrated solutions, an equivalent quantity of the solution shall be furnished. The qualifying activity will request data as noted in 6.2.3 to accompany the qualification samples.

4.2.2 Qualification tests

Qualification sample(s) shall be subject to all the tests specified within section 4.4, methods of inspection.

4.2.3 Retention of qualification

In order to retain qualification of a product approved for listing on the QPL, the manufacturer shall verify, by certification to the qualifying activity, that the manufacturer's product complies with the requirements of this specification. The time of periodic verification by certification shall be in two-year intervals from the date of original qualification. The Government reserves the right to re-examine the qualified product whenever deemed necessary to determine the product continues to meet any or all of the specification requirements.

MIL-PRF-5606H

4.3 Conformance inspection

The conformance inspection shall consist of tests to verify conformance to the following requirements: acid number, barium content, color of finished fluid, copper corrosion, evaporation, flash point, foaming characteristics, low temperature stability, pour point, rubber swell, solid particle contamination, steel-on-steel wear, viscosity of finished fluid, and water content (see *table II*). In the event of a solid particle contamination count failure, the referee method shall be the microscopic method, *ASTM F 312*, using Method A with white and/or black filters at the Government's discretion. Unless otherwise specified by the procuring activity, sampling of the hydraulic fluid shall be in accordance with 4.3.1 and 4.3.2. Inspection shall be in accordance with *FED-STD-791*, Method 9601.

4.3.1 Sampling for tests

Sampling for tests shall be conducted in accordance with *ASTM D 4057* or *ASTM D 4177*. Failure of any conformance test shall result in rejection of the lot. In addition, a random sample of base oil shall be selected for each lot of the finished fluid and subjected to all the applicable conformance tests for base oil.

4.3.2 Sampling for solid particle contamination

Samples of filled and sealed containers shall be taken at periodic intervals to be representative of each day's production in accordance with this specification, *ASQ Z1.4*, Inspection Level S-3. The sample size and number of determinations shall be in accordance with *table IV*.

TABLE IV. Sample for solid particle contamination.

Container	Sample size (ml) 1/	Number of determinations per sample
1 quart	100	1
1 gallon	200	2
5 gallon	300	3
55 gallon	600	6

1/ Each determination shall be made on a 100-ml portion of the sample. If the particle count on any individual determination exceeds the limits of *table III*, two additional determinations on another sample from the same container may be used. The container shall be thoroughly shaken immediately prior to withdrawing each 100-ml portion for such determinations. The average of the two closer particle counts shall be considered the particle count for the sample.

MIL-PRF-5606H

4.4 Methods of inspection

4.4.1 Inspection

Inspection shall be in accordance with method 9601 of *FED-STD-791* and 4.4.3 through 4.4.3.5 of this specification.

4.4.2 Fluid

The fluid shall conform to the requirements for base stock (see 3.3) and additive materials (see 3.2.1 through 3.2.5) and finished fluids (see 3.4) shall be determined by appropriate examination and testing in accordance with 4.4.3.

4.4.3 Physical and chemical values

Tests shall be performed in accordance with the applicable methods specified in *table V* and 4.4.3.1 through 4.4.3.5. Physical and chemical values specified in section 3 apply to the arithmetic average of the determinations made on the samples for those values which fall within any stated repeatability or reproducibility limits of the applicable test method.

4.4.3.1 Gravimetric

The following procedures in addition to the requirements of *ASTM D 4898* shall be followed when performing the gravimetric test:

- a. Use two white, 0.45-micron, cellulose membrane filters.
- b. Prior to use, rinse each filter with filtered hexane; using forceps, place in a covered petri dish; and dry for 15 minutes in a 70°C oven. Store prewashed and dried filters in a petri dish placed in a desiccator with desiccant until ready to use.
- c. Immediately prior to use, remove filters from the desiccator and place in separate covered petri dishes. Dry filters in covered petri dishes for 15 minutes in a 70°C oven. Remove petri dishes from the oven and, with dish covers closed, allow filters to equilibrate to ambient room conditions for 5 minutes before weighing.

MIL-PRF-5606H

TABLE V. Test methods for hydraulic fluid properties.

Characteristic	FED-STD-791 Test Method	ASTM
Acid number		<i>D664</i>
Barium content		<i>D5185</i>
Color		<i>D1500</i>
Corrosiveness and oxidation stability		¹ <i>D4636</i>
Evaporation		² <i>D972</i>
Filtration time	³ <i>3009</i>	
Flash point		<i>D93</i>
Foaming characteristics		<i>D892</i>
Gravimetric		⁴ <i>D4898</i>
Low temperature stability	<i>3458</i>	
Pour point		<i>D97 or D5949</i>
Shear stability		⁵ <i>D2603</i>
Solid particle count automatic	<i>3012</i>	
Specific gravity		<i>D287</i>
Storage stability	<i>3465</i>	
Steel-on-steel wear		⁶ <i>D4172</i>
Swelling of synthetic rubber	<i>3603</i>	
Viscosity		<i>D445</i>
Water		<i>D6304</i>

1 Test shall be run for 168 hours as 135°C. Use heptane or acetone to clean coupons. Use alternate procedure 2.

2 Test shall be run for 6 hours at 71°C.

3 Filtration time shall be measured using a single membrane filter.

4 See 4.4.3.1.

5 See 4.4.3.3.

6 Condition B.

4.4.3.2 Color of finished fluid

The color of the hydraulic fluid shall be compared to a standard sample prepared by adding 1 part red dye to 10,000 parts of an oil not darker than *ASTM D 1500*, standard No. 1.

4.4.3.3 Shear stability

Shear stability tests shall be conducted in accordance with *ASTM D2603*, with the following modifications:

- a. Control fluid is *ASTM Reference Fluid B*.
- b. Run the control fluid and the test fluid consecutively in the same apparatus and under the same test conditions for 30 minutes at 0°C. The equipment is to be such that

MIL-PRF-5606H

the viscosity decrease of the reference fluid (see 6.4.1), at 40°C is approximately 15 percent. Use 30 ml of fluid for this test.

4.4.3.4 Copper strip corrosion

The following procedures shall be followed:

- a. Prepare two copper strips in accordance with *ASTM D 130*.
- b. Fill test tubes or other suitable containers with 90 ml of hydraulic fluid and individually immerse the copper strips into the test tubes.
- c. Immerse each test tube, which will be equipped with an air condenser, in a constant temperature bath capable of maintaining the fluid temperature at 135 +1°C. If an oven is used, vent the air condenser to the outside of the oven. After 72 hours at this test temperature, remove the strips from the fluid, rinse them in isooctane per *ASTM D 130*, and compare the results with the ASTM copper strip corrosion standards.

4.4.3.5 Bulk modulus

The isothermal secant bulk modulus test shall be performed as specified in Appendix A.

4.4.4 Examination of filled containers

Each filled container and shipping container sample shall be examined for construction defects of the container and closure, evidence of leakage, and net content. Any container in the sample that has one or more defects, or is below the required fill, shall be rejected. If the number of defective containers in any sample exceeds the acceptance number for the appropriate sampling plan, the lot represented by the sample shall be rejected. Rejected lots may be resubmitted for acceptance inspection provided the contractor has removed or repaired all nonconforming containers.

5. PACKAGING

5.1 Packaging

For acquisition purposes, the packaging requirements shall be as specified in the contract or order (see 6.2). When actual packaging of materiel is to be performed by DoD personnel, these personnel will contact the responsible packaging activity to ascertain requisite packaging requirements. Packaging requirements are maintained by the Inventory Control Point's packaging activity within the Military Department or Defense Agency, or within the Military Department's Systems Command. Packaging data retrieval is available from the managing Military Department or Defense Agency's automated packaging files, CD-ROM products, or by contacting the responsible packaging activity.

MIL-PRF-5606H

6. NOTES

(This section contains information of a general or explanatory nature that may be helpful, but is not mandatory.)

6.1 Intended use

The hydraulic fluid covered by this specification is intended for use in automatic pilots, shock absorbers, brakes, flap-control mechanisms, missile hydraulic servo-controlled systems, and other hydraulic systems which use synthetic sealing material.

6.1.1 Storage conditions

Prior to use in the intended equipment, the product may be stored under conditions of covered or uncovered storage in geographic areas that range in temperatures from -57°C to +49°C.

6.1.2 Interchangeability

This fluid is completely compatible with *MIL-PRF-6083*, *MIL-PRF-46170*, *MIL-PRF-87257*, and *MIL-PRF-83282* hydraulic fluids. It may be interchangeable with these fluids for some applications. The selection of the fluids to be used depends on the requirements of the operational system.

6.2 Acquisition requirements

Acquisition documents should specify the following:

- a. Title, number, and date of this specification.
- b. Type and size of containers (see 5.1).
- c. Issue of *DoDISS* to be cited in the solicitation and, if required, the specific issue of individual documents referenced (see 2.1 and 2.2).
- d. Quantity.
- e. Selection of applicable levels of packaging and packing with requirements in detail (see 5.1).
- f. Special marking (see 5.1 and 6.6.1).
- g. Toxicological data requirements (3.5.6).

6.2.1 Basis of purchase

MIL-PRF-5606 hydraulic fluid should be purchased in U.S. gallons (volume equal to 231 cubic inches at 15.6°C).

6.2.2 List of qualified products

Products considered acceptable under this specification are listed in *QPL-5606* and subsequent revisions thereto.

6.2.3 Requests for data

Upon application for qualification, the qualifying activity will request the following types of data.

MIL-PRF-5606H

6.2.3.1 Data to accompany qualification samples

The qualifying activity will request that a Material Safety Data Sheet accompany the samples (*FED-STD-313*, Material Safety Data, Transportation Data and Disposal Data for Hazardous Materials Furnished to Government Activities, may be used as guidance). The qualifying activity will also request a test report from the manufacturer or a commercial laboratory that contains complete information about the source and type of base stock and additive materials used, the formulation and composition of the finished fluid, and laboratory data that show quantitative results of all the tests required by this specification except storage stability. Separate qualification inspection is required for each base stock used. The samples should be plainly identified by securely attached, durable tags or labels marked with the following information.

- Sample for Qualification Inspection
- HYDRAULIC FLUID, PETROLEUM BASE; AIRCRAFT, MISSILE, AND ORDNANCE
- Specification MIL-PRF-5606
- Name of ingredient (for ingredient material)
- Name of manufacturer
- Product code number
- Date of manufacture

6.2.3.2 Formulation sheet

An example form is provided below for the formulation sheet, indicating the weight percentage and nature of each ingredient:

Petroleum oil base stock (manufacturer's name and composition)	Percentage
Viscosity index improver (manufacturer's name and number)	Percentage
Anti-wear additive (manufacturer's name and number)	Percentage
Oxidation inhibitor (manufacturer's name and number)	Percentage
Pour point depressant (manufacturer's name and number)	Percentage
Dye (manufacturer's name and number)	Percentage

6.3 Qualification

With respect to products which require qualification, awards will be made only for such products as have, prior to the time set for opening of bids, been tested and approved for inclusion in the applicable QPL, whether or not such products have actually been so listed by that date. The attention of the suppliers is called to this requirement, and manufacturers are urged to arrange to have the products they propose to offer to the Federal Government tested for qualification in order that they may be eligible to be awarded contracts or orders for the products covered by this specification. The activity responsible for the QPL is AFRL/MLBT, Bldg 654, 2941 P St., Wright-Patterson AFB OH 45433-7750. Information pertaining to qualification of products may be obtained from that activity.

MIL-PRF-5606H

6.3.1 Qualification information

It is understood that the material furnished under this specification subsequent to final approval should be of the same composition and should be equal to products upon which approval was originally granted. In the event the fluid furnished under contract is found to deviate from the composition of the approved product, or the product fails to perform satisfactorily, approval of such a product will be subjected to immediate withdrawal from the QPL at the discretion of the Qualifying Agency.

6.4 Samples

6.4.1 Reference fluid

The sample (1 pint) of shear stability reference fluid for the test specified in 4.4.3.3 may be obtained from RohMax USA, Inc., 723 Electronic Dr., Horsham, PA 19044-2228.

6.4.2 Synthetic rubber

Samples of standard synthetic rubber NBR-L should subscribe to the formulation in accordance with *SAE AMS 3217/2*. A suggested source (material) is Akron Rubber Development Laboratory (ARDL), 300 Kenmore Blvd., Akron OH 44301.

6.5 International standardization agreements

Certain provisions of this specification (see 1.1) are the subject of international standardization agreements: *AIR-STD-15/7, Guide Specification For Petroleum Base Aviation Hydraulic Fluids (H-515 AND H-520)*; *AIR-STD-15/9, Interchangeability Chart Of Standardized Aviation Fuels, Lubricants and Allied Products*; *STANAG-1135, Interchangeability of Fuels, Lubricants and Associated Products Used by the Armed Forces of the North Atlantic Treaty Nations*; and *STANAG-3748, Hydraulic Fluids, Petroleum (H-515, H-520 And C-635) and Polyalphaolefin (H-537, H-538, and H-544)*. The Air Standardization Coordinating Committee (ASCC) is responsible for *AIR-STD-15/7* and *AIR-STD-15/9*. *STANAG-1135* and *STANAG-3748* are North Atlantic Treaty Organization (NATO) Standardization Agreements. When amendment, revision, or cancellation of this specification is proposed which will modify the international agreement concerned, the preparing activity will take appropriate action through international standardization channels, including departmental standardization offices, to change the agreement or make other appropriate accommodations.

6.6 Disposal actions

6.6.1 Background

The product may contain up to 3 percent by weight of an anti-wear agent, such as TCP, that conforms to *TT-T-656*, or equivalent. When used, TCP should contain no more than 1 percent of the ortho-isomer. Tricresyl phosphate, which may be absorbed through the skin, can produce paralysis if taken internally. Accumulated waste liquids should have the exterior of the outer pack marked as containing TCP to help disposal facilities manage the product according to regulations promulgated by the US Environmental Protection Agency under *Public Law 94-580, Resource Conservation and Recovery Act of 1976*. Historical practice directed that unit containers be marked with the following warning:

MIL-PRF-5606H

WARNING: This fluid may contain tricresyl phosphate (TCP) which may be absorbed through the skin and produce paralysis if taken internally. Appropriate protective measures should be taken to avoid such exposures. Decontaminate containers before reuse.

6.6.2 Handling and safety precautions

Personnel should wear appropriate, impervious clothing when handling the product to prevent repeated or prolonged skin contact. Local appraisal is required to determine exact health and safety implications and to prescribe precise application of protective clothing. If skin or clothing becomes moistened with the product, personnel should promptly wash with soap or mild detergent and water. Respirators are not required unless there is an inhalation exposure to mists. Personnel should wear protective clothing when using the product and when cleaning up spills.

6.6.3 Disposal

6.6.3.1 Waste fluid

The accumulated waste fluid should be disposed of through a waste oil recovery program unless prohibited by local law. Otherwise, the product should be disposed of in accordance with local law and regulations promulgated by the U.S. Environmental Protection Agency under *Public Law 94-580, Resource Conservation and Recovery Act of 1976*.

6.6.3.2 Depot-type operations

See 6.6.3.1. Additionally, the used product, which has been drained from the hydraulic systems, should be combined with unused but contaminated fluid from partially full containers and then recycled. Fluid may be purified and reused in accordance with T.O. 42B2-1-3.

6.6.3.3 Container disposal

Depending upon local regulations, tops from one-time-use containers may be discarded with ordinary refuse. Containers should be made as empty as possible using gravity draining, after which they are to be crushed and buried in a permitted sanitary landfill or incinerated with general refuse. No special decontamination procedures are required for empty containers or their lids.

6.7 Subject term (key word) listing

additive
anti-wear
bulk modulus
corrosive
flash point
isothermal secant bulk modulus
lubricant
oxidation
pour point
shear stability
viscosity

6.8 Amendment notations.

The margins of this specification are marked with vertical lines to indicate modifications generated by this amendment. Where prudent to indicate specific, significant changes, red text is used. This is done as a convenience only and the Government assumes no liability whatsoever for any inaccuracies in these notations. Bidders and contractors are cautioned to evaluate the requirements of this document based on the entire content irrespective of the marginal notations.

MIL-PRF-5606H

APPENDIX

ISOTHERMAL SECANT BULK MODULUS

A.1. SCOPE

A.1.1 Scope

This appendix describes the bulk modulus test method for compliance with 4.5.3.5 of MIL-PRF-5606H. Except where indicated as guidance (see A.13), this appendix is a mandatory part of the specification.

Note: This test method is under the jurisdiction of ASTM Committee D-2 on Petroleum Products and Lubricants and is the direct responsibility of Subcommittee D02.11 on Engineering Sciences of High Performance Fluids and Solids. For more information, visit the ASTM web site at www.astm.org.

A.1.2 Definition

Isothermal secant bulk modulus is the product of original fluid volume and the slope of the secant drawn from the origin to any specified point on the plot of pressure versus volume reduction divided by volume at constant temperature.

A.1.3 Application

A.1.3.2 Significance

Isothermal secant bulk modulus (static bulk modulus) is a property that measures the compressibility of a liquid. The greater the value, the less compressible the liquid.

A.1.3.3 Use

Isothermal secant bulk modulus is employed in the design of high performance hydraulic fluid and braking systems. High bulk modulus is desirable in that the response time of a system is faster when applied pressure more directly affects the action of the system rather than in the compression of the working liquid.

A.1.4 Test method coverage

This test method covers the determination of isothermal secant bulk modulus of liquids that are stable and compatible with stainless steel under the conditions of test.

A.1.5 Range

The test method is designed to be used within the temperature range of -40°C to 200°C and from ambient to 68.95 MPa (10,000 psig).

Note: Because of the design of the test apparatus, the upper limit of pressure that can be attained is limited by the bulk modulus of the test fluid. Pressures as high as 68.95 MPa will not be attained for fluids of relatively low bulk modulus at the test temperature.

MIL-PRF-5606H

A.1.6 User proficiency

The procedure assumes that the user is proficient in the assembly and use of medium pressure (m/p) threaded and coned fittings which are intended for use at pressures up to 137.9 MPa (20,000 psig).

A.1.7 Safety and health practices

This standard does not purport to address all of the safety concerns, if any, associated with its use. It is the responsibility of the user of the standard to establish appropriate safety and health practices and to determine the applicability of regulatory limitations prior to use.

Note: Because hydraulic pressure in the test system is produced by purely mechanical means, the test method is not subject to the hazards associated with systems that are pressurized pneumatically. Even small leaks will result in immediate drop in pressure to ambient without production of a high-pressure liquid stream or mist.

A.2. APPLICABLE DOCUMENTS

A.2.1 References

A.2.1.2 ASTM standards

ASTM D 235	Standard Specification for Mineral Spirits ¹
ASTM D 4057	Standard Practice for Manual Sampling of Petroleum and Petroleum Products ²
ASTM D 4177	Standard Practice for Automatic Sampling of Petroleum and Petroleum Products ²
ASTM E 300	Standard Practice for Sampling Industrial Chemicals ³

Notes:

- ¹ Annual Book of ASTM Standards, Vol. 5.01
- ² Annual Book of ASTM Standards, Vol. 5.02
- ³ Annual Book of ASTM Standards, Vol. 15.05

A.2.1.3 International Critical Tables

International Critical Tables, Vol. 3, McGraw Hill Co. Inc., New York, NY

A.3. Summary of test method

A.3.1 Determination of isothermal secant bulk modulus

A piston in the form of a medium pressure valve is forced into a liquid-filled chamber. The pressure created by the insertion of the piston shall be measured.

A.3.2 Determination of constant

A system constant $\left(\frac{V_0}{V_0 - V_n} \right)$ shall be determined by use of a standard of known bulk modulus as follows:

MIL-PRF-5606H

$$\left(\frac{V_0}{V_0 - V_n} \right) = \frac{\bar{B}_i}{\Delta P} = \frac{\bar{B}_i}{(P_n - P_0)} \quad (1)$$

Where:

- \bar{B}_i = isothermal secant bulk modulus
- P_0 = pressure at the origin before insertion of the piston
- P_n = pressure of the system at insertion of piston to position n
- V_0 = system volume at zero turn
- V_n = system volume at insertion of piston to position n

Note: $\left(\frac{V_0}{V_0 - V_n} \right)$ is thus a constant determined by system volume and piston displacement

only. It is independent of temperature and, when known, can be used to determine isothermal secant bulk modulus from pressure data obtained for various degrees of piston insertion.

A.4. Apparatus

The apparatus for the determination of isothermal secant bulk modulus is shown schematically on FIGURE 1. An oven capable of maintaining temperature within $\pm 0.1^\circ\text{C}$ at the desired test temperature is required. All fittings are of the coned and threaded m/p type for use at working pressures up to 137.9 MPa (20,000 psig). Pressure is created in the system by use of the pressure valve (3) by which a piston (valve stem) is inserted into the liquid-filled system by turning 1,2,3...n turns as determined by a scale affixed to the valve stem to assure repeatability of turns from the starting point. Pressure transducers, thermocouples and system fixtures shall have minimal contribution to system volume so that the system volume allows a maximum pressure increase for any given degree of insertion of the pressure valve stem.

A.5. Reagents and materials

A.5.1 Cleaning solvent

Cleaning solvent shall consist of mineral spirits conforming to ASTM D 235, Type I.

A.5.2 Other solvents

Some test specimens may not be soluble in mineral spirits. In such cases, a suitable solvent for such materials shall be used to clean the apparatus after their use. The solvent used shall be

MIL-PRF-5606H

compatible with stainless steel and the elastomeric components of the valves in the test apparatus.

A.6. Sampling

A representative sample of the test specimen shall be obtained in accordance with the requirements of ASTM D4057, D4177 or E300.

A.7. Preparation of apparatus

In preparing the test apparatus, the following procedures shall be followed:

- a. Introduce a portion of mineral spirits into the sample container, figure 1, Item 8. Open valves 1 and 4 and slowly draw the mineral spirits through the system by gentle application of vacuum.
- b. Note: Always use a trap between the test apparatus and the vacuum source to prevent introduction of the liquid solvent or the test specimen into the vacuum system.
- c. Replace the sample container with an empty vessel and allow excess solvent to drain from the test system. Repeat sections A.7.a through A.7.b.
- d. Remove the vessel containing excess solvent and with valves 1 and 4 open allow the vacuum pump to draw air through the test system to evaporate the residual solvent. Start at ambient temperature and raise oven temperature to 100°C while drawing air through the system.
- e. When the oven temperature reaches 100°C, close valve 4 and allow the vacuum pump to release the pressure in the test system to complete removal of solvent residues by evaporation.

A.8. Calibration

- a. The following calibration procedures shall be followed:
- b. With the cleaned system at ambient temperature introduce the calibrating fluid (usually water) into container 8.
- c. Open valves 1 and 4 and draw sufficient fluid into the test cell to insure that it is liquid-filled. Close valve 4.
- d. Adjust the oven to the pre-selected test temperature with valve 1 still open and the pressure valve 3 set at the 0 turn or full open position.
- e. Apply vacuum to the system to remove any residual air bubbles. Close valve 1 and record the system pressure with pressure transducer 6.
- f. Turn the pressure valve one full turn and record the pressure. Repeat for turns two through n (usually n = seven) and record the system pressure after each full turn.
- g. Calculate $\left(\frac{V_0}{V_0 - V_n}\right)$ for each pressure valve position as described in section 4.1.2 equation (1). An example is shown in A.13.
- h. Drain the calibration fluid from the test cell. If water was used for calibration, remove all residual traces as described in sections A.7.a through A.7.d. If an organic standard was used, clean the cell in accordance with sections A.7.a through A.7.d.

MIL-PRF-5606H

A.9. Procedure

The test procedures below shall be followed:

- a. Introduce the test specimen into the test cell as described in sections A.8.a to A.8.d. Record the pressure reading at turn 0 of the pressure valve 3.
- b. Turn the pressure valve 1 a full turn and record the pressure. Repeat for turns 2 through n (usually n = 7) and record the system pressure after each full turn.
- c. Calculate the isothermal secant bulk modulus of the test specimen as described in section 10. An example is shown in section A.13.

A.10. Calculation

The following equation shall be used for the calculation:

$$\bar{B}_i = \frac{V_0}{V_0 - V_n} (P_n - P_0) \quad (2)$$

Where:

- \bar{B}_i = Isothermal secant bulk modulus, psi,
- $\frac{V_0}{V_0 - V_n}$ = Ratio of initial volume to volume change as determined by equation (1),
- P_n = Pressure of the system at insertion of piston to position n, psig,
- P_0 = Pressure at origin, (zero turns of piston) psig.

A.11. Report

Report the isothermal secant bulk modulus at the test temperature and whatever pressure is desired within range of pressures observed in sections 11.2 and 11.3. Since isothermal secant bulk modulus is a linear function of pressure with the range from ambient to 68.95 MPa (10,000 psig) extrapolation may be employed to obtain values at pressures above and below those which can be obtained directly (depending upon the actual isothermal secant bulk modulus of the test specimen).

A.12. Precision and bias

Because of the complex nature of the procedure for the determination of isothermal secant bulk modulus, and because of the expensive equipment required in the initial set-up of the procedure, there is not a sufficient number of volunteers to permit a cooperative laboratory program for determination of the precision and bias of the method. If the necessary volunteers can be obtained, a program will be undertaken at a later date.

MIL-PRF-5606H

A.13. Bulk modulus guidance

The information in this section is provided as guidance only.

A.13.1 Isothermal bulk modulus calibration

Calibration Fluid: Water

Calibration Temperature, °C: 40

Data from International Critical Tables:

Pressure, psig	Bulk Modulus
7349	354299
14697	382654

Calibration:

Turn #	[1] P, psig	[2] P _n - P ₀	[3] \bar{B}_i , psi	[4] $\frac{V_0}{V_0 - V_n}$
0	36			
1	1318	1282	330888	258.10300
2	2681	2654	336147	127.08770
3	4084	4048	341561	84.37772
4	5531	5495	347145	63.17470
5	7022	6986	352899	50.51517
6	8549	8513	358791	42.14625
7	10129	10093	364888	36.15258

Notes:

[1] = Pressure readings at the 0 and nth turn of the valve.

[2] = Pressure difference between the nth turn and the 0 turn.

[3] = Secant bulk modulus of the calibration fluid at the observed pressure as obtained by linear interpolation and/or extrapolation.

[4] = Volume constant of the system equal to $\frac{V_0}{V_0 - V_n} = \frac{\bar{B}_i}{(P_n - P_0)}$.

Because the volume constant is a unit-less quantity consisting of a volume divided by a volume difference, it is independent of temperature.

MIL-PRF-5606H

A.13.2 Determination of isothermal secant bulk modulus

Once the volume constant, $\frac{V_0}{V_0 - V_n}$, has been determined for the test system, the data may be used with data obtained with the test specimen to determine its isothermal secant bulk modulus as follows:

$$\bar{B}_i = (P_n - P_0) \frac{V_0}{V_0 - V_n} \quad (3)$$

Test Specimen: unknown hydraulic fluid

Test Temperature, °C: 40

Calibration Fluid: Water at 40°C

Turn #	[1] P, psig	[2] P _n - P ₀	[3] $\frac{V_0}{V_0 - V_n}$	[4] \bar{B}_i , psi
0	36			
1	825	789	258.10300	203644
2	1661	1625	127.08770	206518
3	2545	2509	84.37772	211704
4	3473	3437	63.17470	217132
5	4448	4412	50.51517	222873
6	5470	5434	42.14625	229023
7	6539	6503	36.15258	235101

Notes:

- [1] = Pressure readings at the 0 and nth turn of the pressure valves.
- [2] = Pressure difference between the nth turn and the 0 turn.
- [3] = Volume constant as determined by calibration with a fluid of known isothermal secant bulk modulus.
- [4] = Isothermal secant bulk modulus as determined from equation (3).

MIL-PRF-5606H

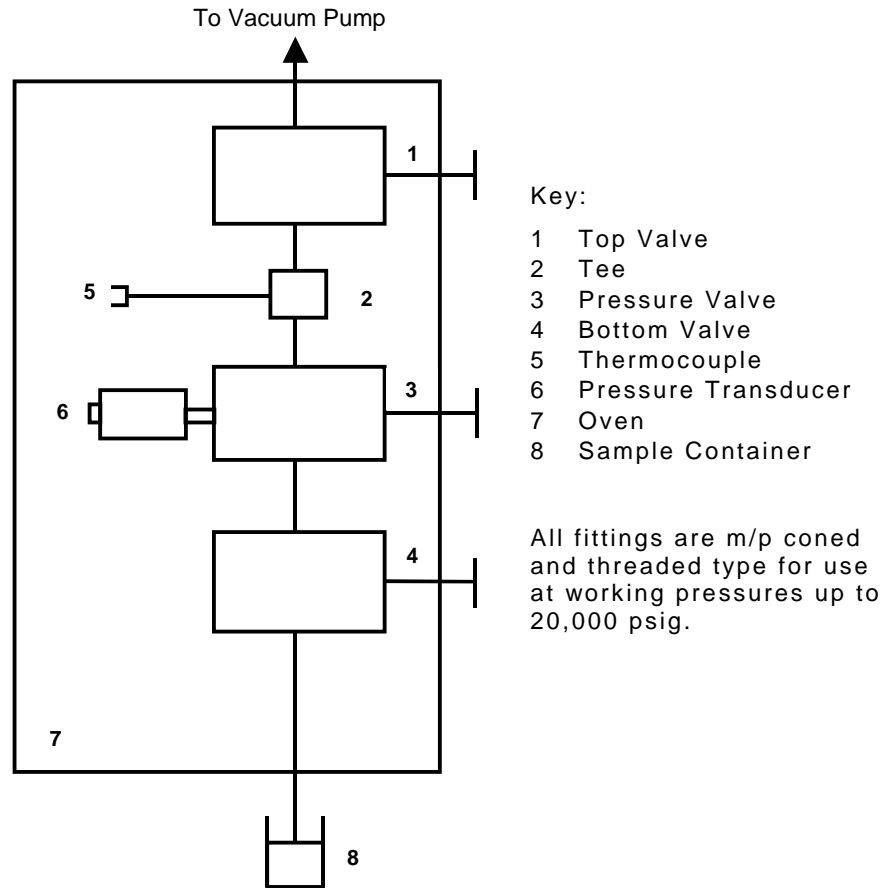

FIGURE 1. Apparatus for determination of secant bulk modulus.

Custodians:

Army – AT
 Navy – AS
 Air Force – 11

Preparing activity:

Air Force – 11

(Project 9150-2005-002)

Review activities:

Army – MI, SM, AR
 Navy – SA, SH, OS
 Air Force -68
 DLA – GS
 DTRA – DS

International Interest:

NATO (See 6.5)

NOTE: The activities listed above were interested in this document as of the date on the cover. Since organizations and responsibilities can change, you should verify the currency of the information above using the ASSIST Online database at <http://assist.daps.dla.mil>.