

MIL-STD-339(AT)
7 December 1987
SUPERSEDING
(see 6.3)

MILITARY STANDARD
WIRING AND WIRING DEVICES
FOR COMBAT AND TACTICAL VEHICLES,
SELECTION AND INSTALLATION OF



AMSC N/A

FSC 6150

DISTRIBUTION STATEMENT A. Approved for public release; distribution is unlimited.

MIL-STD-339(AT)

DEPARTMENT OF DEFENSE
Washington, DC 20301

Wiring and Wiring Devices for Combat and Tactical Vehicles, Selection and Installation of.

1. This Military Standard is approved for use within the US Army Tank-Automotive Command, Department of the Army, and is available for use by all Departments and Agencies of the Department of Defense.
2. Beneficial comments (recommendations, additions, deletions) and any pertinent data which may be of use in improving this document should be addressed to: US Army Tank-Automotive Command, ATTN: AMSTA-GDS, Warren, MI 48397-5000, by using the self-addressed Standardization Document Improvement Proposal (DD Form 1426) appearing at the end of this document or by letter.

MIL-STD-339(AT)

FOREWORD

This standard designates the criteria for (1) the selection of wire, shielding, outer protective coverings, and connectors and associated hardware, and (2) wiring harness and cable assembly fabrication, for use in the design and installation of a complete cable system in combat and tactical vehicles.

The criteria for inclusion of wire, shielding, sheathing, and connectors and associated hardware in this standard are as follows:

- a. The wiring and associated materials shall be suitable for use in military vehicles.
- b. The wiring and associated materials shall be covered by Government specifications.
- c. The wiring and associated materials shall be available for procurement.
- d. The wiring and associated materials shall be suitable for multiple applications.
- e. The wiring and associated materials shall be approved for listing or listed on applicable qualified products lists (QPL).

This standard, due to its complexity and numerous subjects, has been broken down into sections. These sections are labeled numerically and are consecutive in the step-by-step process by which a complete cable system would be designed. Each section is structured to stand alone to allow the designer access to information on specific subjects.

MIL-STD-339(AT)

CONTENTS

	<u>Page</u>
Paragraph 1. SCOPE.....	1
1.1 Scope.....	1
1.2 Purpose and application.....	1
2. APPLICABLE DOCUMENTS.....	2
2.1 Government documents.....	2
2.1.1 Documents.....	2
2.1.2 Standard.....	2
2.2 Order of precedence.....	2
3. DEFINITIONS.....	3
3.1 Section definitions.....	3
4. GENERAL REQUIREMENTS.....	4
4.1 Deviations.....	4
4.2 Conflicting requirements.....	4
4.3 Selection of parts and materials.....	4
4.3.1 Requests for approval of nonstandard parts..	4
4.3.2 Commercial utility parts.....	4
4.3.3 Contractor's specifications.....	4
4.3.4 Commonality.....	5
4.3.5 Government furnished equipment (GFE).....	5
4.3.6 Modification.....	5
4.4 Service life.....	5
5. DETAILED REQUIREMENTS.....	6
 Section No.	
100 Wire and cable.....	7
200 Shield braid.....	23
300 Outer sheath.....	29
400 Connectors.....	35
500 Connector accessory hardware.....	46
600 Wiring harnesses, molded cable assemblies, hybrid cables assemblies, and convolute tubing cable assemblies.....	51
700 Fabrication of wiring harnesses.....	93
800 Fabrication of waterproof wiring harnesses...	97
900 Wiring practices inside enclosures (-94 to +257°F).....	103
1000 Identification of cable assemblies.....	115
1100 In-process and acceptance testing of cable assemblies.....	118
1200 Installation of cable assemblies and wiring devices.....	127

MIL-STD-339(AT)

CONTENTS - Continued.

		<u>Page</u>
6.	NOTES.....	134
6.1	Intended use.....	134
6.2	Subject term (key word) listing.....	134
6.3	Supersession data.....	134
INDEX.....		135

TABLES

Table		
I.	Insulation selection checklist.....	10
II.	Typical properties of thermoplastic materials..	12
III.	Wire data list.....	13
IV.	Current-carrying capacity of copper conductors; single conductor in free air - ambient temperature 30°C.....	19
V.	Ambient temperature over 30°C correction factors.....	20
VI.	Correction factors for current-carrying capacity.....	20
VII.	Recommended braid parameters, #34 AWG.....	26
VIII.	Shield weight and wire diameters.....	27
IX.	Shield diameter increase.....	27
X.	Typical properties of elastometers (for wires, cables, and cords).....	31
XI.	Plastic material properties comparison.....	33
XII.	Characteristics of common military connectors..	38
XIII.	MIL-C-5015 connector contacts.....	40
XIV.	MIL-C-26482 and MIL-C-83723 connector contacts.....	41
XV.	MIL-C-38999 connector contacts.....	42
XVI.	Tensile strength of crimped contacts.....	44
XVII.	Multiconductor cable symbols.....	53
XVIII.	Multiconductor shielded cable symbols.....	53
XIX.	Color coding.....	59
XX.	Multiconductor cable.....	60
XXI.	Lay pattern calculations.....	62
XXII.	Filler factors.....	65
XXIII.	Conductor/cable size.....	98
XXIV.	Tolerances for cable assemblies.....	99
XXV.	Circuit identification.....	101
XXVI.	Nicked or severed strands.....	105
XXVII.	Dimensional tolerances.....	107
XXVIII.	Spacing.....	110

FIGURES

Figure		
1	Functional wire block diagram.....	8
2	Wiring harness.....	55
3	Molded cable assembly.....	57

MIL-STD-339(AT)

CONTENTS - Continued.
FIGURES

		<u>Page</u>
Figure	4	Lay pattern..... 61
	5	Calculation chart..... 64
	6	Mold preparation..... 66
	7	Molding..... 67
	8	Shield terminations..... 69
	9	Hybrid cable assembly..... 70
	10	Connector and breakout termination..... 72
	11	Convolute tubing cable assembly..... 73
	12	Inner/outer shield termination..... 75
	13	Floating shield..... 76
	14	Procedure for center stripping..... 77
	15	Procedure for end stripping..... 78
	16	Ground lead..... 79
	17	Assembly..... 79
	18	Pigtailed braid..... 80
	19	Pigtailed braid assembly..... 80
	20	First two-conductor method using typical terminal..... 106
	21	Second two-conductor method using typical terminal..... 106
	22	Starting tie and spot tie..... 108
	23	Overhand tie..... 108
	24	Finishing tie..... 109
	25	Lead breakoff..... 109
	26	Wrap around..... 111
	27	Normal method..... 112
	28	Adapter method..... 113
	29	Offset method..... 113

MIL-STD-339(AT)

1. SCOPE

1.1 Scope. This standard covers the selection and installation of wiring and wiring devices used in combat and tactical vehicles.

1.2 Purpose and application. This standard establishes design requirements for wiring combat and tactical vehicles. Although many of the requirements are written as mandatory and must be considered as such, there is also considerable material which is intended to denote optional, preferential, or guidance-type requirements. In interpreting the material contained herein, it is intended that the philosophy of the entire document be considered for the wiring of each new type of vehicle. This philosophy is safety of the personnel, safety of the vehicle, satisfactory performance and reliability of the vehicle, and ease of maintenance, all at the least cost to the Government. The intent of this document will be fulfilled by tailoring the requirements in each new type or class of combat and tactical vehicle designed, to the proper application.

MIL-STD-339(AT)

2. REFERENCED DOCUMENTS

2.1 Government documents.

2.1.1 Documents. Since this standard has been broken down into independent sections, the documents are entered at the beginning of each section, with the following exception.

2.1.2 Standard. The following standard of the issue listed in that issue of the Department of Defense Index of Specifications and Standards (DODISS) specified in the solicitation forms a part of this standard to the extent specified herein.

STANDARD
MILITARY

MIL-STD-143

- Standards and Specifications, Order of
Precedence for the Selection of.

(Copies of specifications, standards, handbooks, drawings, and publications required by contractors in connection with specific acquisition functions should be obtained from the contracting activity or as directed by the contracting officer.)

2.2 Order of precedence. In the event of a conflict between the text of this standard and the references cited herein, the text of this standard shall take precedence.

3. DEFINITIONS

3.1 Section definitions. With the breakdown of this standard into independent sections, the definitions are entered separately in each section.

MIL-STD-339(AT)

4. GENERAL REQUIREMENTS

4.1 Deviations. Deviations from this standard desired by the contractor (substitution of equipment, material, or installation) shall be specifically brought to the attention of the procuring activity by letter concurrent with or prior to forwarding the design data for approval. All requests for deviations shall include sufficient engineering information to substantiate the deviations.

4.2 Conflicting requirements. In case of discrepancies between this standard and the type or detail specification for a particular vehicle part, the type or detail specification shall prevail.

4.3 Selection of parts and materials. Parts and materials covered by documents listed herein are standard and shall be used whenever they are suitable for the purpose. Parts and materials shall be procured from QPL sources when they exist. Nonstandard parts and materials must be equivalent to or better than similar standard parts and materials. When this standard fails to provide an applicable specification or standard, the contractor shall use other established specifications or standards in the order of precedence set forth in MIL-STD-143. Parts and materials selected from other than this standard are not standard, and approval must be obtained prior to their use in combat vehicles. Each vendor source for a nonstandard part or material requires approval. When a nonstandard part is used where a suitable standard part exists, the contractor shall reference the standard part on the drawing, parts list, or data package, and the installation shall provide for replacement with the standard part.

4.3.1 Requests for approval of nonstandard parts. The data to be submitted with the request for approval of nonstandard parts shall be in accordance with the terms of the contract.

4.3.2 Commercial utility parts. Commercial utility parts, such as screws, bolts, nuts, cotter pins, etc., may be used, provided they have suitable properties and are replaceable by standard parts without alteration.

4.3.3 Contractor's specifications. Wiring and wiring devices conforming to contractor's specifications may be used, provided each contractor's specification is approved by the procuring activity, and provided no military specification exists. The contractor shall provide substantiating test data and, when required by the procuring activity, shall provide samples for test. The use of contractor's specifications shall not constitute waiver of Government inspections. Contractor's specifications shall follow the format for military specifications. When a detail or general military specification exists for the class of material required, the contractor's specification shall reference the existing military specification and set forth only the needed new requirements and deviations.

MIL-STD-339(AT)

4.3.4 Commonality. An objective in the selection of parts shall be to maximize commonality and minimize the variety of wiring components and related servicing tools required in the construction, installation, and maintenance of the electrical wiring system.

4.3.5 Government Furnished Equipment (GFE). Wiring and wiring devices furnished by the Government shall be installed without modification unless otherwise authorized or directed by the procuring activity.

4.3.6 Modification. The contractor shall not alter, rework, or modify wiring or wiring devices built to and meeting Government specifications unless authorized or directed by the procuring activity, and such modification shall be subject to Government inspection. Modified parts shall have the Government identifying part number removed.

4.4 Service life. The wiring and associated components used for making the wiring installation shall be so selected and installed that their expected service life is not less than that of the vehicle structure.

MIL-STD-339(AT)

5. DETAILED REQUIREMENTS

This section of the standard is divided into 12 sections (sections 100 to 1200), each covering a specific subject.

MIL-STD-339(AT)
SECTION 100
WIRE AND CABLE

100.1 SCOPE

100.1.1 Scope. This section covers the material selection for wire and cable.

100.2 REFERENCED DOCUMENTS

100.2.1 Government documents.

100.2.1.1 Specifications and handbook. Unless otherwise specified, the following specifications and handbook of the issue listed in that issue of the Department of Defense Index of Specifications and Standards (DoDISS) specified in the solicitation form a part of this standard to the extent specified herein.

SPECIFICATIONS
MILITARY

MIL-C-17	- Cables, Radio Frequency, Flexible and Semi-Rigid, General Specification for.
MIL-W-16878	- Wire, Electrical, Insulated, General Specification for.
MIL-W-22759	- Wire, Electric, Fluoropolymer-Insulated, Abrasion Resistant, Extruded TFE, Medium Weight, Silver-Coated Copper Conductor, 600-Volt.
MIL-C-27500	- Cable, Electrical Shielded and Unshielded, Aerospace.
MIL-W-81044	- Wire, Electric, Crosslinked Polyalkene, Crosslinked, Alkane-Imide Polymer, or Polyarylene Insulated, Copper or Copper Alloy.
MIL-W-81381	- Wire, Electric, Polyimide-Insulated, Copper or Copper Alloy.
MIL-T-81490	- Transmission Lines, Transverse Electromagnetic Mode.

HANDBOOK
MILITARY

MIL-HDBK-216	- R.F. Transmission Lines and Fittings.
--------------	---

(Copies of specifications, standards, handbooks, drawings, and publications required by contractors in connection with specific acquisition functions should be obtained from the contracting activity or as directed by the contracting officer.)

100.2.2 Order of precedence. In the event of a conflict between the text of this standard and the references cited herein, the text of this standard shall take precedence.

MIL-STD-339(AT)
 SECTION 100
 WIRE AND CABLE

100.3 REQUIREMENTS

100.3.1 Preliminary design. The designer faced with the problem of designing an electrical system must carefully weigh a large number of variables. Each variable within the system must be identified. The first step would be to construct a block diagram which will show each function in an appropriately identified rectangle. The rectangles are connected by lines which represent the approximate direction of the wires or cables (see figure 1).

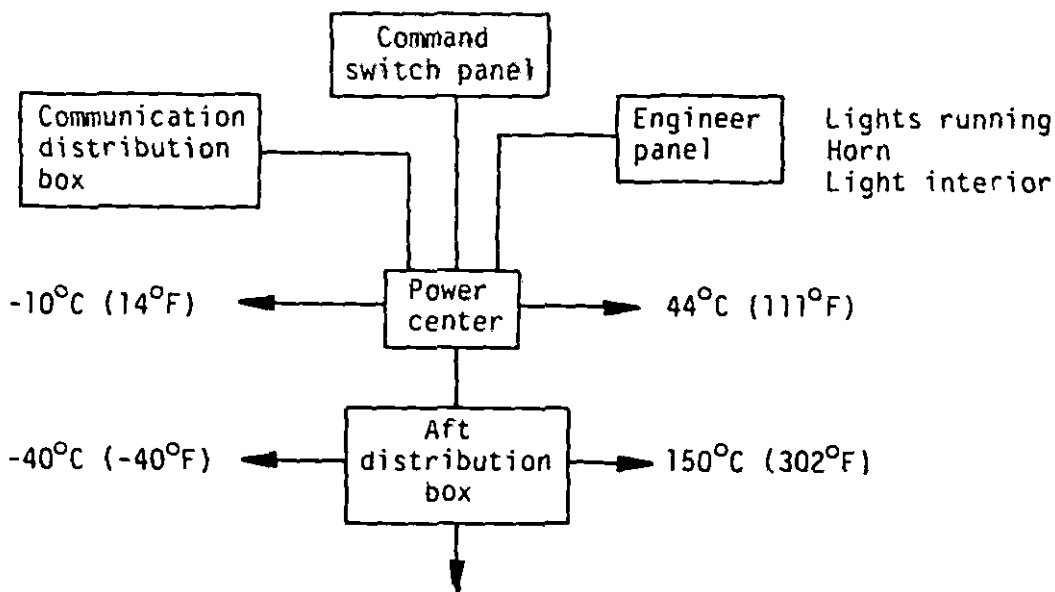

FIGURE 1. Functional wire block diagram.

Note: This block diagram should list all appropriate main functions and sub-functions within a specific design. Having completed this diagram, the next step is to add environments which may be encountered, i.e., temperature, high and low. These temperature requirements may vary within the system, therefore each temperature should be listed. Additionally, other environments must be listed such as:

- a. Fluid immersion (list all fluids).
- b. Vibration.
- c. Shock, thermal and impact.
- d. Fungus.
- e. Smoke and fire.
- f. Sand and dust.
- etc.

MIL-STD-339(AT)
SECTION 100
WIRE AND CABLE

As the preliminary design progresses, changes will occur which may affect the cable design, such as structure, new equipment, or voltage-amperage requirements. Each new input will necessitate a reassessment of the design.

100.3.2 Component selection. Wiring shall be selected so as not to be subjected to conditions exceeding the limits specified in the applicable wiring component specification and in accordance with the following requirements.

100.3.3 Wiring selection. Wiring shall be of a type suitable for the application. Wire shall be selected so that the rated maximum conductor temperature is not exceeded for any combination of electrical loading, ambient temperature, and heating effects of bundles, conduit, and other enclosures. Factors to be considered in the selection are voltage, current, ambient temperature, mechanical strength, abrasion, and flexure requirements. Wiring shall be selected in accordance with table I and shall conform to the following requirements or design considerations.

100.3.3.1 Elevated-temperature degradation. Degradation of tin- and silver-plated copper conductors will occur if they are exposed to continuous operation at elevated temperatures. These effects shall be taken into account in the selection and application of wiring.

100.3.3.1.1 Tin-plated conductors. Tin-copper interfaces result in an increase in conductor resistance. The resistance increases inversely with size, increasing up to 4 percent for the smallest gage.

100.3.3.1.2 Silver-plated conductors. Degradation in the form of interstrand bonding, silver migration, and oxidation of the copper strands will occur with continuous operation near rated temperature, resulting in loss of flexibility. Due to a potential fire hazard, silver-plated conductors shall not be used in areas where they are subject to contamination by ethylene glycol solutions. These conditions should be considered in the application of wiring utilizing these conductors.

100.3.3.1.3 Solderability. Both tin-plated and silver-plated copper conductors exhibit poor solderability after exposure to continuous elevated temperatures. Compensating steps shall be included in maintenance procedures for retermination.

MIL-STD-339(AT)

SECTION 100

WIRE AND CABLE

TABLE I. Insulation selection checklist.

Requirement	Considerations
1. <u>Environment</u>	
a. <u>Temperature extremes</u>	
(1) Continuous operating	Refer to tables II and III
(2) Short term operating	May require test that simulates specific application.
(3) Fabrication temperature	Check for soldering iron resistance in high-density packaging; cure temperature of encapsulant; compatibility with shrinkable devices, if employed.
(4) Storage	Check for embrittlement, long-term storage, low-humidity conditions.
b. <u>Altitude</u>	
(1) Outgassing	Weight loss, smoke, condensation.
(2) Corona	Maintain voltage below corona level, especially with insulation susceptible to erosion.
c. <u>Radiation</u>	Refer to table II.
d. <u>Weather</u>	Moisture resistance, aging, ultra-violet radiation.
e. <u>Flame</u>	Refer to table II.
f. <u>Fluids</u>	Refer to table II.
2. <u>Electrical</u>	
a. <u>Capacitance</u>	$C = \frac{7.36K}{\text{Log } (10 D/d)}$
	Where C = Capacitance, picofarads per foot (pf/ft).
	K = Dielectric constant (table II).
	D = Insulated wire diameter, inclusive.
	d = Conductor diameter, inches.

MIL-STD-339(AT)
 SECTION 100
 WIRE AND CABLE

TABLE I. Insulation selection checklist - Continued.

Requirement	Considerations
b. <u>Dielectric strength</u>	Refer to table II.
c. <u>Volume resistivity</u>	Refer to table II.
d. <u>Loss factor</u>	Refer to table II.
3. <u>Mechanical</u>	
a. <u>Installation and handling</u>	Check for minimum bend radius, special tooling, clamping, stresses, chafing. Refer to tables II and III for abrasion, cut-through, and mechanical resistance.
b. <u>Operating</u>	Refer to table III.
4. <u>Size</u>	Refer to applicable specification for outside dimensions.
5. <u>Weight</u>	Refer to applicable specification for maximum weight. If not listed, use the following equation for insulation weight:
	$W = \frac{Dd^2}{2} \text{ KG lb/1000 ft.}$
	where D = Diameter over insulation, inches. d = Diameter over conductor K = 680 G = Specific gravity of insulation, table II.

TABLE 11. Typical properties of thermoplastic materials.

Insulation	Common designation	Tensile strength (PSI)	Elongation (%)	Specific gravity	Abrasion resistance	Volume resistivity (ohm-cm)	Dielectric constant (1kHz)	Temp range (°C)	Dielectric strength (V/MIL)	Fluid resistance	Flammability	Radiation resistance $\frac{1}{3}$	Comments
Polyvinyl Chloride	PVC	3,000	200	1.35	Poor	8×10^{15}	5.0	+105 -40	400	Good	Slow to Self-extinguish	$10^7 - 10^8$	Good, low cost, general purpose; greatly influenced by plasticizers. Same as above.
Polyvinyl Chloride	PVC	2,000	375	1.21	Poor	1×10^{12}	6.0	+60 -65	400	Good	Slow to Self-extinguish.	$10^7 - 10^8$	Same as above.
Polyethylene Low Density	PE	2,200	625	.92	Poor	1×10^{17}	2.25	+70 -65	480	Excell	Flammable	$10^8 - 10^9$	Excellent electrical, tough and chemically resistant; weak in creep and thermal resistance.
Polyethylene High Density	PE	3,400	250	.947	Good	1×10^{17}	2.32	+70 -65	480	Excell	Flammable	$10^7 - 10^8$	Same as above. Thermal stability increases with density.
Polypropylene (Unfilled)		5,000	200	.902	Good	1×10^{17}	2.22	+125 -20	750	Good	Self-extinguish	$10^6 - 10^7$	Similar to low density polyethylene.
Nylon 610		8,000	200	1.08	Excell	1×10^{14}	4.5	+105 -40	470	Good	Self-extinguish	$10^6 - 10^7$	Good mechanical and abrasion resistance; poor moisture resistance.
Polytetrafluoroethylene	TFE	3,500	300	2.18	Fair	1×10^{18}	2.0	+260 -80	480	Excell	Non-flammable	$10^4 - 10^5$	Outstanding electrical poor cold flow & cut through resistance. Nearly inert chemically.
Fluorinated Ethylene	FEP	3,000	250	2.16	Poor	1×10^{18}	2.1	+200 -80	500	Excell	Non-flammable	$10^5 - 10^6$	Properties similar to TFE Extrudable.
Polychlorotetrafluoroethylene	KEL P ¹ / _(CTFE)	5,000	150	2.16	Good	1×10^{18}	2.3	+135 -65	500	Good	Non-flammable	$10^6 - 10^7$	Excellent electrical properties, stiffer than TE and FEP but low cost.
Polyvinylidene Fluoride	KYNAR ² / _(VF-2)	7,000	300	1.76	Good	1×10^{14}	8.0	+135 -65	260	Good	Self-extinguish	$10^6 - 10^7$	
Polyurethane (Ether Type)		6,000	600	1.25	Good	2×10^{11}	7.5	+75 -60	400	Fair	Slow	$10^8 - 10^9$	

¹/ Trademark of 3M Company
²/ Registered Trademark of Pennwalt Co.
³/ Gamma Exposure, rad.

MIL-STD-339(AT)

**SECTION 100
 WIRE AND CABLE**

TABLE III. Wire data list.

Basic specification	Type class	Size range (AWG #)	Conductor coating	Primary insulation	Jacket material/s	Voltage rating	Temperature rating (C°)	Duty rating 2/		
MIL-W-16878/1 /1 /2 /3 /4 /5 /6 /7 /8	B	32-14	Tin	PVC	Nylon	600	-55 +105	M		
	BN	32-14	Tin	PVC		600	-55 +105	H		
	C	26-12	Tin	PVC		1000	-55 +105	M		
	D	24-1/0	Tin	PVC		3000	-55 +105	M		
	E	32-10	Silver	TFE		600	-55 +200	M		
	EE	32-8	Nickel	TFE		600	-55 +260	M		
	ET	32-20	Silver	TFE		1000	-55 +200	M		
	F	24-4/0	Nickel	TFE		1000	-55 +260	M		
	FF	24-4/0	Tin, Silver	TFE		1000	-55 +200	M		
	MIL-W-22759 /10 /11 /12 /13	J	24-4/0	Nickel		Silicon Rubber	Glass, TFE Glass, TFE Glass, TFE Glass, FEP	600	-55 +75	M
		K	32-10	Tin		Polyethylene FEP		600	-55 +200	M
		KK	32-8	Silver		FEP		1000	-55 +200	M
		KT	32-20	Silver		FEP		250	-55 +200	L
/1		22-4/0	Silver	TFE	600	-55 +200		M		
/2		22-4/0	Nickel	TFE	600	-55 +260		M		
/3		22-2/0	Nickel	TFE tape	600	-55 +260		M		
/4		22-2/0	Silver	TFE tape	600	-55 +200		M		
/5		24-4	Silver	TFE	600	-55 +200		M		
/6		24-4	Nickel	TFE	600	-55 +260		H		
/7	24-4	Silver	TFE	600	-55 +200	H				
/8	24-4	Nickel	TFE	600	-55 +260	M				
/9	28-8	Silver	TFE	1000	-55 +200	M				
/10	28-8	Nickel	TFE	1000	-55 +260	M				

TABLE III. Wire data list - Continued.

Basic specification	Type class	Size range (AWG #)	Conductor coating	Primary insulation	Jacket material/s	Voltage rating	Temperature rating (C°)	Duty rating <u>2/</u>	
MIL-W-22759	/11	28-12	Silver	TFE		600	-55 +200	M	
	/12	28-8	Nickel	TFE		600	-55 +260	M	
	/13	24-1/0	Tin	FEP	PVF 2	600	-55 +135	M	
	/14	26-12	Tin	FEP	PVF 2	600	-55 +135	L	
	/15	26-30	Silver	FEP	PVF 2	600	-55 +135	L	
	/16	24-2/0	Tin	ETFE		600	-65 +150	M	
	/17	26-20	Silver	ETFE		600	-65 +150	M	
	/18	26-10	Tin	ETFE		600	-65 +150	L	
	/19	26-20	Silver	ETFE		600	-65 +200	L	
	/20	28-20	Silver	TFE		1000	-65 +200	---	
	/21	28-20	Nickel	TFE		1000	-65 +260	---	
	/22	28-20	Silver	TFE		600	-65 +200	---	
	/23	28-20	Nickel	TFE		600	-65 +260	---	
	/24	24-2/0	Tin	ECTFE		600	-65 +150	M	
	/25	26-20	Silver	ECTFE		600	-65 +150	M	
	/26	26-10	Tin	ECTFE		600	-65 +150	L	
	/27	26-20	Silver	ECTFE		600	-65 +150	L	
	/28	28-8	Silver	TFE		600	-65 +200	---	
	/29	28-8	Nickel	TFE		600	-65 +260	---	
	/30	28-20	Silver	TFE		600	-65 +200	---	
	/31	28-20	Nickel	TFE		600	-65 +260	---	
	/32	30-12	Tin	ETFE			-65 +150	L	
	/33								
	/34	24-2/0	Tin	ETFE Double		Polyamide Braid	600	-65 +150	N
	/35								
	/36								
	/37	24-12	Tin	Polyalkene		ECTFE	600	-65 +135	M
	/38	26-20	Silver	Polyalkene		ECTFE	600	-65 +135	L
	/39	26-10	Tin	Polyalkene		ECTFE	600	-65 +135	L-M
	/40	26-20	Silver	Polyalkene		ECTFE	600	-65 +135	L-M

SECTION 100
WIRE AND CABLE

TABLE III. Wire data list - Continued.

Basic specification	Type class	Size range (AWG #)	Conductor coating	Primary insulation	Jacket material/s	Voltage rating	Temperature rating (C°)	Duty rating 2/	
MIL-W-81044	/41	26-2/0	Nickel	ETFE Double	Polyamide Braid	600	-65 +200	N	
	/1		Silver	Polyalkene		600	-65 +135	L	
	/2		Tin	Polyalkene		600	-65 +135	L	
	/3		Silver	Polyalkene		600	-65 +135	N	
	/4		Tin	Polyalkene		600	-65 +135	N	
	/5		Silver	Polyalkene		600	-65 +150	N	
	/6		Tin	Polyalkene		600	-65 +150	N	
	/7		Silver	Polyalkene		600	-65 +150	N	
	/8		Silver	Polyalkene		600	-65 +150	M	
	/9		Tin	Polyalkene		600	-65 +150	M	
	/10	24-1/0	Silver	Polyalkene		600	-65 +150	M	
	/11		Silver	Polyalkene		600	-65 +150	L	
	/12	30-12	Tin	Polyalkene		600	-65 +150	L	
	/13		Silver	Polyalkene		600	-65 +150	L	
	/14		Tin	Polyalkene		600	-65 +135	M	
	/15		Silver	Polyalkene		600	-65 +135	M	
	/16	24-2/0	Tin	Polyalkene	Alkane-Imide	Imide Polymer	600	-65 +150	N
	/17		Silver	Polyalkene	Alkane-Imide		600	-65 +150	N
	/18		Tin	Polyalkene	Alkane-Imide		600	-65 +150	L
	/19		Silver	Polyalkene	Alkane-Imide		600	-65 +150	L
	/20		Tin	Polyalkene	Polyarylene		600	-65 +160	n
	/21		Silver	Polyalkene	Polyarylene		600	-65 +200	N
	/22		Silver	Polyalkene	Polyarylene		600	-65 +200	N
	/23		Nickel	Polyalkene	Polyarylene		600	-65 +260	N
	/24		Nickel	Polyalkene	Polyarlene		600	-65 +260	N
	/25		Tin	Polyalkene	Polyarylene		600	-65 +150	1
	/26		Silver	Polyalkene	Polyarylene		600	-65 +200	L
	/27		Silver	Polyalkene	Polyarylene		600	-65 +200	L
/28		Nickel	Polyalkene	Polyarylene		600	-65 +260	L	

MIL-STD-339(AT)
SECTION 100
WIRE AND CABLE

TABLE III. Wire data list - Continued.

Basic specification	Type class	Size range (AWG #)	Conductor coating	Primary insulation	Jacket material/s	Voltage rating	Temperature rating (C°)	Duty rating 2/
MIL-W-81381	/29	26-10	Nickel	Polyarylene FEP	FEP	600	-65 +260	L
	/1		Silver					L
	/2	26-10	Nickel	Polyimide FEP	FEP	600	+200	L
	/3		Silver					M
	/4	26-2	Nickel	Polyimide FEP	FEP	600	+200	M
	/5		Silver					M
	/6	26-20	Nickel	Polyimide FEP	FEP	600	+200	1
	/7		Silver					L
	/8	26-10	Nickel	Polyimide FEP	Aromatic Polyimide	600	+200	L
	/9		Silver					L
	/10	30-20	Nickel	Polyimide FEP	Aromatic Polyimide	600	+200	1
	/11		Silver					M
	/12	24-2	Nickel	Polyimide FEP	Aromatic Polyimide	600	+200	M
	/13		Silver					m
	/14	28-20	Nickel	Polyimide FEP	Aromatic Polyimide	600	+200	M
	/15		--					--
/16	--	--	--	Cancelled	15 Jan 1971	---	---	--
			--	Cancelled	15 Jan 1971	---	---	--

TABLE III. Wire data list - Continued.

Basic specification	Type class	Size range (AWG #)	Conductor coating	Primary insulation	Jacket material/s	Voltage rating	Temperature rating (C°)	Duty rating 2/	
MIL-W-81044	/41	26-2/0	Nickel	ETFE Double	Polyamide Braid	600	-65 +200	N	
	/1		Silver	Polyalkene		600	-65 +135	L	
	/2		Tin	Polyalkene		600	-65 +135	L	
	/3		Silver	Polyalkene		600	-65 +135	N	
	/4		Tin	Polyalkene		600	-65 +135	N	
	/5		Silver	Polyalkene		600	-65 +150	N	
	/6		Tin	Polyalkene		600	-65 +150	N	
	/7		Silver	Polyalkene		600	-65 +150	M	
	/8		Silver	Polyalkene		600	-65 +150	M	
	/9		Tin	Polyalkene		600	-65 +150	M	
	/10		Silver	Polyalkene		600	-65 +150	L	
	/11		Silver	Polyalkene		600	-65 +150	L	
	/12		Tin	Polyalkene		600	-65 +150	L	
	/13		Silver	Polyalkene		600	-65 +150	M	
	/14		Tin	Polyalkene		600	-65 +135	M	
	/15		Silver	Polyalkene		600	-65 +135	N	
	/16		Tin	Alkane-Imide	Alkane-Imide	Imide Polymer	600	-65 +150	N
	/17		Silver	Alkane-Imide	Alkane-Imide		600	-65 +150	L
	/18		Tin	Alkane-Imide	Alkane-Imide		600	-65 +150	L
	/19		Silver	Alkane-Imide	Alkane-Imide		600	-65 +150	n
	/20		Tin	Polyarylene	Polyarylene		600	-65 +160	N
	/21		Silver	Polyarylene	Polyarylene		600	-65 +200	N
	/22		Silver	Polyarylene	Polyarylene		600	-65 +200	N
	/23		Nickel	Polyarylene	Polyarylene		600	-65 +260	N
	/24		Nickel	Polyarylene	Polyarylene		600	-65 +260	L
	/25		Tin	Polyarylene	Polyarylene		600	-65 +150	L
	/26		Silver	Polyarylene	Polyarylene		600	-65 +200	L
	/27		Silver	Polyarylene	Polyarylene		600	-65 +200	L
/28		Nickel	Polyarylene	Polyarylene		600	-65 +260	L	

MIL-STD-339(AT)
 SECTION 100
 WIRE AND CABLE

TABLE III. Wire data list - Continued.

Basic specification	Type class	Size range (AWG #)	Conductor coating	Primary insulation	Jacket material/s	Voltage rating	Temperature rating (C°)	Duty rating 2/	
MIL-W-81381	/29 /1	26-10	Nickel Silver	Polyarylene FEP	FEP	600 600	-65 +260 +200	L L	
	/2	26-10	Nickel	Polyimide FEP	FEP	600	+200	L	
	/3	26-2	Silver	Polyimide FEP	FEP	600	+200	M	
	/4	26-2	Nickel	Polyimide FEP	FEP	600	+200	M	
	/5	26-20	Silver	Polyimide FEP	FEP	600	+200	1	
	/6	26-20	Nickel	Polyimide FEP	FEP	600	+200	L	
	/7	26-10	Silver	Polyimide FEP	Aromatic Polyimide	600	+200	L	
	/8	26-10	Nickel	Polyimide FEP	Aromatic Polyimide	600	+200	L	
	/9	30-20	Silver	Polyimide FEP	Aromatic Polyimide	600	+200	L	
	/10	30-20	Nickel	Polyimide FEP	Aromatic Polyimide	600	+200	1	
	/11	24-2	Silver	Polyimide FEP	Aromatic Polyimide	600	+200	M	
	/12	24-2	Nickel	Polyimide FEP	Aromatic Polyimide	600	+200	M	
	/13	28-20	Silver	Polyimide FEP	Aromatic Polyimide	600	+200	m	
	/14	28-20	Nickel	Polyimide FEP	Aromatic Polyimide	600	+200	M	
	/15 /16	-- --	-- --	-- --	Polyimide Cancelled Cancelled	15 Jan 1971 15 Jan 1971	--- ---	--- ---	-- --

TABLE III. Wire data list - Continued.

Basic specification	Type class	Size range (AWG #)	Conductor coating	Primary insulation	Jacket material/s	Voltage rating	Temperature rating (C°)	Duty rating <u>2/</u>
	/17	26-12	Silver	FEP Polyimide	Aromatic Polyimide	600	+200	L
	/18	26-12	Nickel	FEP Polyimide	Aromatic Polyimide	600	+200	L
	/19	30-20	Silver	FEP Polyimide	Aromatic Polyimide	600	+200	L
	/20	30-20	Nickel	FEP Polyimide	Aromatic Polyimide	600	+200	L
	/21	26-10	Tin	FEP Polyimide	Aromatic Polyimide	600	+150	L
	/22	24-2/0	Tin	FEP Polyimide	Aromatic Polyimide	600	+150	L M

1/ AWG = American wire gage
 2/ Duty rating: L = light, M = medium, H = heavy, N = normal

MIL-STD-339(AT)
SECTION 100
WIRE AND CABLE

100.3.3.2 Coaxial cables. Coaxial cables shall be suitable for the application and shall be selected in accordance with MIL-C-17. MIL-HDEK-216 shall be used as a guide in their selection. Transverse Electromagnetic Mode (TEM) transmission lines shall be selected in accordance with MIL-T-81490.

100.3.3.3 High-density wiring. The use of high-density wiring shall be dictated by the wiring design considerations and shall be determined by the contractor. Details of the wiring are subject to the approval of the procuring activity.

100.3.3.4 Insulation compatibility with sealing and servicing. Wiring termination in devices where the wiring must be sealed to provide an environmental-proof joint shall be insulation compatible with the sealing feature of the device. Elastomer grommets are generally qualified to seal on wires having smooth extruded insulations. Only one wire per grommet hole is permitted. Sealing on wrapped, braided, striped, or other than smooth circular insulations shall be specifically tested for compatibility and shall be subject to procuring activity approval, unless compatibility has been demonstrated in the qualification of the terminating device. The wiring shall be installed so that transverse loads will not destroy the integrity of the sealing feature of the grommet.

100.3.3.4.1 Wire diameter. The finished wire outside diameter shall be within the limits specified in the connector specifications and shall not exceed the capability of contact servicing tools to insert and release contacts.

100.3.3.4.2 Potting seal on wire. Where potting is used, the sealing compound shall bond to the wire insulation.

100.3.3.4.3 Insulation degradation. Wiring shall be handled, stripped, and installed so as not to distort, roughen, or damage the insulation at the seal. Methods of marking and identification shall be applied so as not to provide a path for moisture entry. The impression left on the insulation of shielded and twisted wires can also cause unacceptable degradation of the insulation in relation to the elastomer seal. Caution shall be used to avoid this condition.

100.3.3.5 Corona prevention. When a high-voltage difference is applied between a conductor and ground so that an intervening air or gas is overstressed, the air or gas becomes conducting and a flashover (or dielectric failure) may occur. For purposes of this discussion, high voltage is defined as voltages in excess of 240 volts root mean square (V rms). More often, intervening solid insulation does not fully conduct and a "partial discharge" or ionization, or corona, occurs in the gas. These "partial discharges" or ionizations are undesirable for the following reasons. First, the discharges are noise sources which can interfere with low-level signals in associated circuitry. Second, these discharges produce degradation of the insulation and can lead to early failure. Third, the by-products of ionization can be deleterious to associated circuitry, since they include ozone and sometimes corrosive acids.

MIL-STD-339(AT)
 SECTION 100
 WIRE AND CABLE

Parameters to be considered:

- a. Voltage to ground.
- b. Operating frequency.
- c. Ambient air temperature.
- d. Required current-carrying capacity.
- e. Environmental conditions.
- f. Mechanical requirements.

100.3.3.6 Current-carrying capacity. Current-carrying capacity (ampacity) is the maximum amount of current a conductor can carry without heating beyond a safe limit. Other factors that influence ampacity are:

- a. Conductor material. Ampacity is affected by conductivity of the current-carrying member.
- b. Ambient temperature. The higher the surrounding temperature, the less heat required to reach the maximum allowable temperature (see table IV).
- c. Insulation type. The degree to which heat is conducted through the insulation.
- d. Installation method. In air, conduit, duct, or tray. Bundling, stacking, and spacing all affect heat dissipation (see table V).
- e. Installation environment. Heat dissipation by conduction, convection, forced air flow, air conditioning, etc.
- f. Number of conductors. Single conductors have a higher ampacity rating than equivalent size conductors in a cable (see table VI).
- g. Amperage. Heat rise varies as the square of the applied current.

TABLE IV. Current-carrying capacity of copper conductors; single conductor in free air - ambient temperature 30°C.

Size AWG #	Amperes per conductor				
	Copper temperature				
	80°C	90°C	105°C	125°C	200°C
30	2	3	3	3	4
28	3	4	4	5	6
26	4	5	5	6	7
24	6	7	7	8	10
22	8	9	10	11	13
20	10	12	13	14	17
18	15	17	18	20	24
16	19	22	24	26	32
14	27	30	33	40	45

TABLE IV. Current-carrying capacity of copper conductors; single conductor in free air - ambient temperature 30°C - Continued.

Size AWG #	Amperes per conductor				
	Copper temperature				
	80°C	90°C	105°C	125°C	200°C
12	36	40	45	50	55
10	47	55	58	70	75
8	65	70	75	90	100
6	95	100	105	125	135
4	125	135	145	170	180
2	170	180	200	225	240

TABLE V. Ambient temperature over 30°C correction factors.

°C	Correction factor				
	Conductor temperature				
	80°C	90°C	105°C	125°C	200°C
40	.88	.90	.92	.95	---
45	.82	.85	.87	.92	---
50	.75	.80	.82	.89	---
55	.67	.74	.78	.86	---
60	.58	.67	.73	.83	.91
70	.35	.52	.61	.76	.87
80	---	.30	.46	.69	.84
90	---	---	.30	.61	.80
100	---	---	---	.51	.77
120	---	---	---	---	.69
140	---	---	---	---	.59

TABLE VI. Correction factors for current-carrying capacity.

No. of conductors in bundles	Multiplying factor
1	1.6
2 - 3	1.0
4 - 5	0.8
6 - 15	0.7
16 - 30	0.5

MIL-STD-339(AT)
SECTION 100
WIRE AND CABLE

100.3.3.7 Ambient temperature. The contractor shall assure that the maximum ambient temperature the wire bundles will be subjected to, plus the temperature rise due to the wire current loads, does not exceed the maximum conductor temperature rating.

100.3.3.8 Wires terminated in connectors. The continuous current ratings derived from wire application cannot be directly applied to connector contacts. Connector contact ratings are dependent upon the thermal and physical properties of the materials used to manufacture the contact and the connector. The contractor shall assure that the continuous current values, as determined by this design, do not create internal hot spots that exceed the temperature designated by the connector specification during steady-state or transient conditions.

100.3.3.9 Voltage drop. Voltage drop is a major factor in low-voltage systems, except where leads (wires) are very short. At high-ambient temperatures or high-voltage installations, current-carrying capacity controls selection. If several loads are supplied by a single protector, the circuit protector becomes the significant factor. If voltage drop is the major consideration, a single wire of sufficient Circular Mil Area (CMA) should be used to save weight, but if current-carrying capacity is significant, two or more parallel wires will generally weigh less than a single wire of the same total current-carrying capacity. Parallel wires should be of the same gage and length for even current split.

Normal voltage drop limits do not apply to starting currents of equipment such as motors. The voltage at load during start up should be considered to ensure proper operation of equipment. Ampere-inches are the product of wire length between terminations in inches and wire current in amperes. An approximation of voltage drop can be made from the following formula:

$$V = I \times 6 \times \frac{R}{1000} \times 1.004 (T-20)$$

Where V = Voltage drop (volts)
I = Current (amperes)
R = Resistance per 1000 ft.
T = Estimated wire temperature under load, °C
L = Length of wire, ft.

Refer to paragraph 100.3.3.6 and tables IV, V and VI for additional information.

100.3.3.10 Wire and cable identification. Each wire and cable shall be marked with an identification code on the jacket or sleeving of the wire and cable, per the detailed wire and cable specifications.

100.3.3.11 Cable selection. The preceding paragraphs have dealt with single wire constructions only. In order to select cable (one or more conductors, shielded or unshielded, jacketed or unjacketed), the designer should refer to MIL-C-27500.

MIL-STD-339(AT)
SECTION 100
WIRE AND CABLE

100.4 QUALITY ASSURANCE PROVISIONS

100.4.1 Inspections. Inspections shall be performed in accordance with the applicable military specification or drawing.

100.5 PACKAGING

100.5.1 Preservation, apckaging, packing, and marking. Preservation, packaging, packing, and marking for the desired level shall be in accordance with the applicable drawing or packaging requirements specified by the contracting authority.

100.6 NOTES

100.6.1 Definitions. See section 600.

MIL-STD-339(AT)
SECTION 200
SHIELD BRAID

200.1 SCOPE

200.1.1 Scope. This section covers the material, method, and type of shield braid.

200.2 APPLICABLE DOCUMENTS

200.2.1 Government document.

200.2.1.1 Standard. The following standard forms a part of this standard to the extent specified herein. Unless otherwise specified, the issue of this document shall be that listed in the issue of the Department of Defense Index of Specifications and Standards (DODISS) and supplement thereto, cited in the solicitation.

STANDARD
MILITARY

MIL-STD-461 - Electromagnetic Emission and Susceptibility Requirements for the Control of Electromagnetic Interference.

(Copies of specifications, standards, handbooks, drawings, publications, and other Government documents required by the contractors in connection with specific acquisition functions should be obtained from the contracting activity or as directed by the contracting activity.)

200.2.2 Other publications. The following documents form a part of this standard to the extent specified herein. Unless otherwise specified, the issues of the documents which are DOD adopted shall be those listed in the issue of the DODISS specified in the solicitation. Unless otherwise specified, the issues of documents not listed in the DODISS shall be the issue of the nongovernment documents which is current on the date of the solicitation.

AMERICAN SOCIETY FOR TESTING AND MATERIALS (ASTM)

ASTM B3 - Soft or Annealed Copper Wire.
ASTM B33 - Tinned Soft or Annealed Copper Wire for Electrical Purposes.
ASTM B298 - Silver-Coated Soft or Annealed Copper Wire.
ASTM B355 - Nickel-Coated Soft or Annealed Copper Wire.

(Application for copies should be addressed to the American Society for Testing and Materials, 1916 Race Street, Philadelphia, PA 19103.)

(Nongovernment standards and other publications are normally available from the organizations which prepare or which distribute the documents. These documents also may be available in or through libraries or other informational services.)

MIL-STD-339(AT)
SECTION 200
SHIELD BRAID

200.2.3 Order of precedence. In the event of a conflict between the text of this standard and the references cited herein, the text of this standard shall take precedence.

200.3 REQUIREMENTS

200.3.1 Introduction. Shields perform many important functions - some electrical, some mechanical. In electrical and electronic circuits they may level out surge impedance along the length of the cable, screen a signal from external excitation, or confine a signal to an intended electrical path. The actual requirements for shielding should be specified on the equipment drawing, and due to the complexity of these requirements, would require a more comprehensive study than this section would allow. Therefore, only the basic concepts will be discussed. Additional information may be found in MIL-STD-461.

200.3.2 Shield effectiveness. Stray magnetic and electrostatic fields can critically affect signal transmission in electric and electronic circuits by inducing voltages that alter transmitted signals. Shield effectiveness is a measure of the success of a shield in reducing induced voltages and signal radiation. In selecting a particular shield construction, the design engineer must identify the potential fields in which the circuit will operate and specify a construction that reduces radiation and interference to the specified level or limits. The optimum shielding system is usually the minimum cost and weight construction that performs this function and meets applicable environmental and mechanical requirements.

200.3.3 Magnetic shielding. Magnetic shielding is employed under three conditions (see 200.3.3.1 through 200.3.3.3).

200.3.3.1 D.C. and low-frequency. Magnetic materials are effective against D.C., and low-frequency magnetic fields tend to short-circuit the flux lines which attempt to extend through the shield. In this case, shield effectiveness is directly proportional to the thickness; the reluctance that the shield offers to magnetic flux is inversely proportional to thickness (reluctance is the opposition to carrying flux which permeates a material). Therefore shields of high permeability (receptiveness of a material to having flux set up in it), such as permalloy or steel, should be used - particularly at audio or power frequencies (60 Hz).

200.3.3.2 Radio frequencies. At radio frequencies the most practical shield for magnetic flux is made of material having low electrical resistivity (high conductivity) such as copper or aluminum. In attempting to pass through such a shield, magnetic flux induces voltages in the braid giving rise to eddy currents. These oppose the action of the flux, and in a large measure prevent its penetration through the shield.

In critical low-level applications, it may be necessary to employ alternate layers of high-permeability and high-conductivity shields. Physical separation of the layers by a dielectric plays a high important role, particularly in interference from power sources with high-current levels.

200.3.3.3 1 kHz to 1 MHz. Between 1 kHz and 1 MHz, the shields most commonly used for magnetic protection, in order of decreasing effectiveness, are:

- a. Copper and steel.
- b. .005-inch copper tape wrap.
- c. Copper braid 95 percent coverage.
- d. Copper braid 50 percent coverage.
- e. .004-inch aluminum tape.
- f. Aluminized paper.

200.3.4 Electrostatic shielding. Electrostatic shielding does not present as severe a problem as magnetic shielding, since neither shield thickness nor the degree of conductivity is critical. The most important factor in electrostatic shield effectiveness is percent coverage - 100 percent being desirable, but impractical. A generally effective electrostatic shield is provided by a braid made from any fair to good electrical conductor. A braided or tape shield with a ground wire is generally the least expensive and most effective against high-frequency electric fields.

200.3.5 Shield types. There are many shield varieties: round wire shields (braided, spiral, reverse spiral); tape shields (all metal, metal laminate with insulating material); and conductive textiles and plastic (not used too extensively in cables).

200.3.5.1 Round wire shields. Most round wire shields are constructed from bare, tinned, silver, or nickel-plated copper wire. These wire shields are formed from #40 to #28 AWG wire, with #36 to #30 AWG being the most common. Shielding data is found in table VII (ref. ASTM B3, B33, B298, and B355).

200.3.6 Shield coverage. The shielding effectiveness is generally proportional to the amount of coverage. It is usually expressed as a percentage of the total cable surface physically covered by the metal. From an electrical standpoint, 100 percent coverage in braided shields is unattainable. Areas where leakage can occur, however minute, will always exist at points where strands cross (called windows). For the majority of audio-frequency applications, 75 to 85 percent coverage will prove effective; at higher frequencies, 85 to 95 percent coverage will probably be necessary. When even greater effectiveness is required, a double-braided shield, giving up to 97 percent coverage, may be used.

200.3.6.1 Percent coverage. The percent coverage of braided shields can be calculated from the following formula:

$$K = 100 (2F - F^2)$$

where $F = \frac{NPd}{\sin a}$
 $a = \text{Braid Angle}$
 $\tan a = \frac{2 \pi (D + 2d)P}{C}$

MIL-STD-339(AT)

SECTION 200

SHIELD BRAID

- C = Number of carriers
- d = Diameter of braid wire in inches
- D = Diameter of cable under the shield in inches
- K = Percent coverage
- N = Number of ends (wires) per carrier
- P = Picks per inch

200.3.6.1.1 Number of ends per carrier (N). Four to 7 is the general rule, with 10 being the maximum. Anything over 10 the individual ends do not lay flat to the carrier and tend to cross over. The number of ends effects attenuation, push back characteristics, and, in combination with the number of picks per inch (P), the braid angle and percent of coverage.

200.3.6.1.2 Picks per inch (P). Usually kept between 10 and 30. Since picks per inch and braider output vary inversely, the number should be kept to a minimum. Changing the number of ends per carrier or picks per inch alters the braid angle (see definitions, section 600). Best results are achieved when the angle is between 20 and 45 degrees, with 42 degrees being the best compromise for attenuation and braiding speed. A higher braid angle also increases flexibility and flex life.

200.3.6.1.3 Carriers (C). Carriers are metal or wooden bobbins which are used to carry the wires/ends in the braiding operation. Most braiders use 12, 24, 36, 48, and 64 carriers.

TABLE VII. Recommended braid parameters, #34 AWG.

Wire bundle diameter with wrap	1st Layer			2nd Layer		
	No. carriers (C)	Strands per carrier (N)	Picks per inch (P)	No. carriers (C)	Strands per carrier (N)	Picks per inch (P)
.14 ± .02	16	6	11.3	16	7	9.7
.13 ± .02	16	7	9.7	16	8	8.5
.22 ± .02	16	8	8.5	24	9	7.6
.25 ± .03	24	6	12.5	24	7	10.5
.28 ± .03	24	7	10.5	24	8	9.0
.34 ± .04	24	8	9.0	24	9	8.0
.38 ± .06	24	9	8.0	24	10	7.5
.48 ± .05	36	8	9.5	36	8	9.0
.55 ± .06	36	9	8.5	36	9	8.0
.62 ± .06	36	10	7.5	36	10	7.0
.66 ± .07	48	8	9.5	48	8	9.0
.75 ± .08	48	9	8.5	48	9	8.0
.84 ± .09	48	10	7.5	48	10	7.0
.91 ± .09	48	11	7.0	48	11	6.5
.98 ± .10	48	12	6.5	48	12	6.0
1.13 ± .13	64	10	7.5	64	10	7.0
1.22 ± .12	64	11	7.0	64	11	6.5

MIL-STD-339(AT)
 SECTION 200
 SHIELD BRAID

200.3.7 Additional useful information. Additional formulas and tables:

TABLE VIII. Shield weight and wire diameters.

Size (AWG #)	D (inches)	W (lbs/Mft)
40	0.0031	0.0291
38	0.0040	0.0481
36	0.0050	0.0757
34	0.0063	0.1200
32	0.0080	0.1940
30	0.0100	0.303
28	0.0130	0.481

TABLE IX. Shield diameter increase.

(Shield O.D. = Cable Dia + Addition)

Size (AWG #)	Addition (inches)
40	0.014
38	0.018
36	0.022
34	0.028
32	0.035
30	0.044
28	0.056

Shielded Weight Formula

$$\text{Weight} = \frac{NCW}{\cos a} \times 1.03 = \text{lbs/Mft}$$

Where: N = Number of ends per carrier
 C = Number of carriers
 W = Weight of one strand (lbs/Mft)
 a = Braid angle

200.4 QUALITY ASSURANCE PROVISIONS

200.4.1 Inspections. Inspections shall be performed in accordance with the applicable military specification or drawing.

MIL-STD-339(AT)
SECTION 200
SHIELD BRAID

200.5 PACKAGING

200.5.1 Preservation, packaging, packing, and marking. Preservation, packaging, packing, and marking for the desired level shall be in accordance with the applicable drawing or packaging requirements specified by the contracting authority.

200.6 NOTES

200.6.1 Definitions. See section 600.

MIL-STD-339(AT)
SECTION 300
OUTER SHEATH

300.1 SCOPE

300.1.1 Scope. This section covers the material selection for outer sheath (jacketing).

300.2. APPLICABLE DOCUMENTS

300.2.1 Government documents.

300.2.1.1 Specifications. The following specifications form a part of this standard to the extent specified herein. Unless otherwise specified, the issues of these documents shall be those listed in the issue of the Department of Defense Index of Specifications and Standards (DODISS) and supplement thereto, cited in the solicitation.

SPECIFICATIONS
FEDERAL

ZZ-R-765 - Rubber, Silicone (General Specification).

MILITARY

MIL-R-6855 - Rubber, Synthetic, Sheets, Strips, Molded or Extruded Shapes.
MIL-C-13909 - Conduit, Metal, Flexible; Electrical, Shielded.
MIL-I-23053 - Insulation Sleeving, Electrical, Heat Shrinkable, General Specification for.
MIL-R-46846 - Rubber, Synthetic, Heat-Shrinkable.
MIL-T-81914 - Tubing, Plastic, Flexible, Convoluted, Conduit, General Specification for.

(Copies of specifications, standards, handbooks, drawings, publications, and other Government documents required by the contractors in connection with specific acquisition functions should be obtained from the contracting activity or as directed by the contracting activity.)

300.2.2 Order of precedence. In the event of a conflict between the text of this standard and the references cited herein, the text of this standard shall take precedence.

300.3 REQUIREMENTS

300.3.1 Introduction. Outer sheath as defined for this section is a cover to protect the enclosed wires against mechanical damage, chemical attack, fire, and other elements which may be present in the operating environment. Generally, there are three types of outer sheath: tapes, resilient tubing, and convoluted tubing (see 300.3.2 through 300.3.4.2).

300.3.2 Tape. Spiral wrap tapes are used on harness-type assemblies and are not covered in this section.

MIL-STD-339(AT)
SECTION 300
OUTER SHEATH

300.3.3 Resilient extruded tubing. Resilient extruded tubing is used on molded cable assemblies and is limited in material selection. Restrictions are due to available molding compounds suitable for use with specific jacket materials. Material selection for jacketing is discussed in the following paragraphs (see 300.3.3.1 through 300.3.3.4 and table X).

300.3.3.1 Polyurethanes. Polyurethanes at room temperature have physical properties of a very rough rubber, although they are essentially true thermoplastic materials. Both ether and ester types have excellent tensile and elongation properties and provide the toughest, most abrasion-resistant jacketing material available. Polyurethanes possess good resistance to most liquid fuels and oils but are swollen or dissolved by halogenated solvents and a variety of ketones, esters, and polar solvents. The resins have outstanding ozone resistance and resistance to radiation damage. The electrical properties of the polyurethane formulations are entirely adequate for jacketing applications, but marginal for primary insulations. The polyurethane thermoplastics are used almost exclusively for jacketing.

300.3.3.2 Rubbers. Rubbers are thermoset elastomers, which means that the application of heat results in the formation of a material which cannot be reformed; it is set. Hence, although these materials are extruded, they are extruded cold or only mildly heated and later subjected to a heating cycle which causes them to "crosslink" or "vulcanize" into their familiar form. Details of extruded tubing are defined in MIL-R-6855 covering synthetic rubber for specific applications. A short description of various rubbers used as jacketing materials follows.

300.3.3.2.1 Natural rubber (polyisoprene). The physical properties of natural rubber are excellent and offer a wide range of compounding possibilities. The electrical properties of specifically compounded natural rubber are good. It is generally resistant to water, but its resistance to liquid fuels and oils is inferior to that of some synthetic elastomers. It is used as jacketing over flexible cords and in some heavy-duty applications.

300.3.3.2.2 Chloroprene rubber (neoprene). Compounds made from these rubbers are generally characterized by poorer electrical properties than natural rubber, SBR, and butyl. Neoprene has good weathering properties, oil resistance, ozone resistance, and good mechanical toughness. This combination of properties has led to its being currently the most widely used jacketing material within its temperature range.

300.3.3.2.3 Styrene-butadiene rubbers. These copolymers are also known by designations GR-S, BUNAS, and SBR. The electrical properties of specifically compounded SBR are good. It is superior to natural rubber in resistance to aging, but somewhat inferior in general physical properties. Its water and solvent resistance is generally comparable with that of natural rubber. It is used as jacketing in the same areas as natural rubber.

TABLE X. Typical properties of elastomers (for wires, cables, and cords).

Insulation	Common designation	Tensile strength (PSI)	Elongation (%)	Specific gravity	Abrasion resistance	Volume resistivity (ohm-cm)	Dielectric constant (1kHz)	Dissipation factor (1kHz)	Temp. range (°C)	Dielectric strength (V/mil)	Fluid resistance	Flammability	Comments
Natural Rubber	---	1,500-4,000	300-700	1.3-1.7	Excell	$10^{13}-10^{15}$	3.3-5.0	0.01-0.035	+75-55	450-600	Poor	Flammable	Excellent physical properties. Good resistance to cutting, gouging, low heat, ozone, and oil.
Styrene Butadiene	SBR	800-2,500	350-650	1.15-1.55	Excell	$10^{12}-10^{15}$	3.5-5.0	0.006-0.035	+90-55	450-600	Poor	Flammable	Poor oil, ozone, and weather resistance.
Polychloroprene	Neoprene	1,200-2,700	300-700	1.14-1.65	Good	$10^{11}-10^{13}$	5.0-7.0	0.02-0.05	+90-55	100-500	Good	Self-Extinguish	Excellent resistance to heat, ozone, oil, weather, etc. Not so good electrically.
Isobutylene Isoprene	Buryl	500-1,500	300-800	1.15-1.65	Fair	$10^{13}-10^{16}$	3.2-5.0	0.008-0.035	+90-55	400-500	Good	Flammable	Excellent weather resistance. Good resistance to ozone and aging, low tensile strength and resilience.
Polysiloxane	Silicone	500-1,500	100-600	1.10-1.55	Poor	$10^{13}-10^{16}$	2.9-3.5	0.002-0.020	+200-65	300-700	Poor	Flammable	Low strength, high compression set, good electrical stability.
Chlorosulfonated Polyethylene	Hypalon	1,200-2,200	300-600	1.35-1.70	Good	$10^{12}-10^{14}$	9.0-11.0	0.05-0.08	+90-55	400-600	Good	Flammable	Excellent ozone, acid, and weather resistance.
Ethylene Propylene	EPR	1,000-2,500	300-600	1.25-1.45	Good	$10^{13}-10^{16}$	3.2-5.0	0.007-0.035	+90-55	700-900	Poor	Flammable	Good aging, heat, and abrasion resistance.

300.3.3.2.4 Butyl rubber. Butyl elastomers are copolymers of isobutylene and small amounts of isoprene. Specifically compounded formulations have excellent electrical properties and can be used on high-voltage power cables having voltage ratings in excess of 25,000 V. Butyl rubbers are characterized by generally superior weathering and ozone resistance, low water absorption, and good resistance to heat aging. They are considerably inferior to neoprene in oil resistance.

300.3.3.2.5 Silicone rubber. The silicone elastomer can be broadly divided into three classifications. Two classifications would be considered standard and low-temperature properties. The third is the fluorinated silicones having the widest thermal operating range of elastomers. All silicone elastomers are flammable, but their unique structure is such that a non-conductive ash remains after burning. The mechanical properties of abrasion resistance and cut-through resistance are inferior to those of many other elastomers. The electrical properties, however, are very good. They can be compounded to have a relatively low dielectric constant and dissipation factor. Their ability to resist corona and ozone is excellent. These properties make silicone rubber a useful high-voltage insulation where temperature or flexibility requirements rule out the use of butyl rubber. Silicone rubber also possesses a good ability to resist radiation damage. Details of extruded tubing are defined in ZZ-R-765.

300.3.3.3 Chlorosulfonated polyethylene (hypalon). Compounds formulated from these elastomers are characterized by their excellent resistance to ozone, common oils, liquid fuels, weathering, flame, and corona. Hypalon vulcanizates have reasonably good physical properties but are not particularly resilient.

300.3.3.4 Heat-shrinkable tubing. When heat-shrinkable tubing is used as an outer sheath, the tubing shall be selected from MIL-I-23053 and MIL-R-46846.

300.3.4 Convolute tubing. Convolute tubing is supplied either in nonmetallic or metallic materials. Convolute tubing is used as a component in cable systems where ease of accessibility for repair of individual conductors and removal of electronic components with all cables intact is required. The convolute tubing provides a minimum weight material that gives a great degree of flexibility and maintains maximum mechanical and environmental protection of the wiring system (see table XI). Plastic convolute tubing performs within the continuous operating temperature range from -67°F (-55°C) to 500°F (260°C) and may be selected from MIL-T-81914. Metal convolute tubing may be selected from MIL-C-13909.

MIL-STD-339(AT)
SECTION 300
OUTER SHEATH

TABLE XI. Plastic material properties comparison.

Material property	Teflon PFA	Teflon PTFE	Teflon FEP	Tefzel ETFE
Service temp. (C°)	-70 +260	-70 +260	-70 +204	-55 +150
Tensile strength (psi)	3000	2500	2500	5000
Elongation (%)	250	175	200	100
Dielectric strength (V)	12,000	12,000	12,000	12,000
Volume resistivity (ohm.cm)	10 ¹⁸	10 ¹⁸	10 ¹⁸	10 ¹⁶
% Water absorption	.03	.01	.01	.02
Solvent resistance	No swelling, stickiness, or weight change			
Flammability	Non-burning			
Fungus resistance	Does not support fungus growth			

300.3.4.1 Size. In determining the diameter of conduit to be used, the wiring which is to be installed therein shall be bundled together and the maximum diameter measured. The maximum diameter shall not exceed 80 percent of the internal diameter of the conduit. Maximum diameter wire and cable permitted by applicable specifications shall be used or allowed for when making this measurement.

300.3.4.2 Fittings. Type of fittings should be recommended by the manufacturer of the convolute tubing and must be designed for the environmental conditions to be encountered, subject to approval by the procuring activity.

300.4 QUALITY ASSURANCE PROVISIONS

300.4.1 Inspections. Inspections shall be performed in accordance with the applicable military specification or drawing.

MIL-STD-339(AT)
SECTION 300
OUTER SHEATH

300.5. PACKAGING

300.5.1 Preservation, packaging, packing, and marking. Preservation, packaging, packing, and marking for the desired level shall be in accordance with the applicable drawing or packaging requirements specified by the contracting authority.

300.6 NOTES

300.6.1 Definitions. See section 600.

MIL-STD-339(AT)
SECTION 400
CONNECTORS

400.1 SCOPE

400.1.1 Scope. This section covers the material selection for connectors.

400.1.2 Purpose. The purpose of this section is to provide information for selecting the proper connector for a particular cable/wiring harness requirement.

400.2 APPLICABLE DOCUMENTS

400.2.1 Government documents.

400.2.1.1 Specifications, standards, and handbook. The following specifications, standards, and handbook form a part of this standard to the extent specified herein. Unless otherwise specified, the issues of these documents shall be those listed in the issue of the Department of Defense Index of Specifications and Standards (DODISS) and supplement thereto, cited in the solicitation.

SPECIFICATIONS
MILITARY

- | | |
|-------------|---|
| MIL-C-3607 | - Connectors, Coaxial, Radio Frequency, Series Pulse, General Specification for. |
| MIL-C-3650 | - Connector, Coaxial, Radio Frequency, Series LC. |
| MIL-C-3655 | - Connector, Coaxial, Radio Frequency, Series Twin, and Associated Fitting, General Specification for. |
| MIL-C-5015 | - Connectors, Electrical, Circular Threaded, AN Type, General Specification for. |
| MIL-B-7883 | - Brazing of Steels, Copper, Copper Alloys, Nickel Alloys, Aluminum and Aluminum Alloys. |
| MIL-C-22520 | - Crimping Tools, Terminal, Hand or Power Actuated, Wire Termination, and Tool Kits, General Specification for. |
| MIL-C-25516 | - Connectors, Electrical, Miniature, Coaxial, Environment Resistance Type, General Specification for. |
| MIL-C-26482 | - Connectors, Electrical, (Circular, Miniature, Quick Disconnect, Environment Resisting), Receptacles and Plugs, General Specification for. |
| MIL-C-26637 | - Connectors, Coaxial, Radio Frequency, Series LT, General Specification for. |

MIL-STD-339(AT)
SECTION 400
CONNECTORS

- MIL-C-38999 - Connectors, Electrical, Circular, Miniature, High Density, Quick Disconnect (Bayonet, Threaded, and Breech Coupling), Environment Resistant, Removable Crimp, and Hermetic Solder Contacts, General Specification for.
- MIL-C-39012 - Connectors, Coaxial, Radio Frequency, General Specification for.
- MIL-C-39029 - Contacts, Electrical Connector, General Specification for.
- MIL-C-83723 - Connectors, Electrical, Circular, (Environment Resisting), Receptacles and Plugs, General Specification for.

STANDARDS
MILITARY

- MIL-STD-454 - Standard General Requirements for Electronic Equipment.
- MIL-STD-1353 - Electrical Connectors, Plug-In Sockets and Associated Hardware, Selection and Use of.
- MS3100 - Connector, Receptacle, Electric, Wall Mounting, Solder Contacts, AN Type.
- MS3400 - Connectors, Receptacle, Electric, Wall Mounting, Front Release, Crimp Contact.
- MS3450 - Connectors, Receptacle, Electrical, Wall Mounting, Rear Release, Crimp Contact, AN Type.
- MS3459 - Connector Plug, Electrical, Self-Locking, Coupling Nut, Rear Release, Crimp Contact, AN Type.
- MS27534 - Tool, Contact Insertion-Extraction, Electrical Connector.

HANDBOOK
MILITARY

- MIL-HDBK-216 - R.F. Transmission Lines and Fittings.

(Copies of specifications, standards, handbooks, drawings, publications, and other Government documents required by the contractors in connection with specific acquisition functions should be obtained from the contracting activity or as directed by the contracting activity.)

400.2.3 Order of precedence. In the event of a conflict between the text of this standard and the references cited herein, the text of this standard shall take precedence.

MIL-STD-339(AT)
SECTION 400
CONNECTORS

400.3 REQUIREMENTS

400.3.1 Introduction. The connector type most often used is the cylindrical, multicontact, coupled type. The coupling mechanism is either threaded, bayonet, or push-pull. The bayonet coupling is considered better suited for applications where vibration and shock considerations are important and is the most popular type for most applications. A major consideration is the need for sealing against extreme environmental conditions. The use of elastomers at the various interfaces and at the wire grommet seal has been found to be necessary to permit connectors to withstand chemical attack and environmental extremes, including wide temperature-exposure ranges. For most of the removable crimp contacts, the designs include retaining clips in the insert rather than on the contact itself. This is done to avoid tearing of the sealing grommets. Another approach has been the use of a plastic contact retention disk to replace the retaining clip. The nonsealed connectors are already available in a wide variety of plastics and have demonstrated their ability to meet the less stringent requirements. Some connectors of the unsealed type are also available with the capability to accept single-conductor or coaxial-type contacts interchangeably in any position.

400.3.2 Selection. The equipment designer responsible for the selection of a suitable connector should refer to MIL-STD-1353 and follow the guidelines outlined under general requirements. Table XII provides an overall view of major circular connectors available and lists coupling method, termination type, contact size, and temperature range for easy selection of a suitable connector. After a preliminary selection from table XII, a review of the applicable connector specification should be made to ensure the connector will meet all design parameters required. The review should include investigation of accessory hardware necessary to provide environmental sealing requirement or shield coverage through the mating connectors.

400.3.3 Connectors. Except for hermetic connectors with only pin-type design, connectors shall be selected so that contacts on the "live" or "hot" side of the connection are socket type rather than pin type to minimize personal hazard and to prevent accidental shorting of live circuits when the connector is unmated.

400.3.4 Moistureproof connectors. Connectors shall be sealed against the ingress of water and water vapor under all service conditions, including changes in altitude, humidity, and temperature. The connectors shall have an interfacial seal as well as sealing at wire ends. Environment-resisting connectors having wire-sealing grommets are preferred; however, potting may be used where a grommet seal connector would not be suitable. Wiring terminated at connectors shall have insulation compatible with the sealing feature.

TABLE XII. Characteristics of common military connectors.

	Coupling		Terminal		Contact size							Temperature range (°C)					Characteristics			
	Threaded	Bayonet	Push-pull	Crimp	Solder	0	4	8	12	16	20	22D	24	-55 to 175	-55 to 150	-55 to 200		-65 to 200	-65 to 150	
MIL-C																				
-5015					X															AN type, standard size, cylindrical, environmental and nonenvironmental solder and removable crimp contacts.
MS3100	X			X	X	X	X	X	X	X				X						
MS3400	X			X	X	X	X	X	X	X				X						
MS3450	X			X	X	X	X	X	X	X				X						
-26482					X															Miniature circular connectors, bayonet coupling, crimp and solder-type contacts. Environmentally sealed.
Series 1		X		X	X					X	X									
Series 2		X		X	X					X	X									
-38999					X															Miniature, bayonet, removable crimp contacts, for special weapons-system, established reliability.
Series 1		X		X	X					X	X									
Series 2		X		X	X					X	X									
-83723					X															Miniature, circular connectors, threaded and bayonet, environmentally sealed, removable crimp and solder contacts.
Series 3	X			X	X					X	X									

1/ Solder contacts, hermetic only.

MIL-STD-339(AT)
SECTION 400
CONNECTORS

400.3.5 Fireproof and firewall connectors. The connectors shall be thread-coupled, self-locking connectors having corrosion-resistant steel shells and crimp contacts. Where it is necessary to maintain electrical continuity for a limited time under continuous flame, both the receptacle and the mating plug shall be MS3459 class KS or KT series of MIL-C-5015, MIL-C-83723/95, and MIL-C-83723/96 firewall class connectors or any threaded, self-locking class K connector that has been developed for any existing or new military connector specification. If flame integrity only is necessary without the need for electrical continuity, only the receptacle needs to meet the class K requirements.

400.3.6 Coaxial connectors. Coaxial connectors shall be suitable for the application and shall be covered by military specifications such as MIL-C-3607 for pulse series, MIL-C-3650 for LC series, MIL-C-3655 for twin series, MIL-C-25516 for environment-resisting series, MIL-C-26637 for LT series, and MIL-C-39012 for SMA, SMC, BNC, TNC, N, SMB, C, and SC series. Only category D and C connectors of MIL-C-39012 will be used for all applications using braided coaxial cables and category E connectors of MIL-C-39012 will be used for applications using semi-rigid coaxial cables. Where connector parameters beyond the scope of the military specifications are required, non-standard commercial types may be utilized provided the general requirements of the applicable military specifications are met and approved by the procuring activity. MIL-HDBK-216 shall be used as a selection guide.

400.3.7 Connector installation. Connectors shall be used to join cables to cables or to equipment when frequent disconnection is required to remove or service equipment, components, or wiring. Adequate space shall be provided for mating and unmating connectors without the use of tools. At least 3/4 inch shall be provided between the coupling rings of circular connectors. Circular connectors, when installed with the axis in a horizontal direction, shall be positioned so that the master keyway is located at the top. When installed with the axis in a vertical direction, the master keyway shall be located forward in relation to the vehicle. Connectors shall be located and installed so that they will not provide hand holds or foot rests to operating and maintenance personnel, or be damaged by cargo and stored material. Both plug and receptacle shall be visible for engagement and orientation of polarizing key(s). Mated plugs shall not be strained by the attached wiring. Connectors in pressurized structures shall preferably be installed with the flange on the high-pressure side. Ground power connectors shall be installed with the small contacts at the bottom (6 o'clock position).

400.3.8 Adjacent locations. The use of identical connectors in adjacent locations shall be avoided. Difference in size or insert arrangements are preferred. Where identical connectors are used in adjacent locations, wiring shall be so routed and supported that improper connections cannot be made. Adjacent connectors using the same insert arrangement shall be selected to

MIL-STD-339(AT)
SECTION 400
CONNECTORS

take advantage of alternate insert positions or alternate shell keying positions. If this requirement cannot be met, color-coded sleeves having the identification of the associated receptacles shall be attached to the wiring near the plugs. The receptacle shall be color-coded by a color band on the mounting structure.

400.3.9 Contacts. Connectors using removable crimp contacts are preferred to solder contact types. Contacts shall be in accordance with MIL-C-39029. Tables XIII, XIV, and XV provide a capsule summary of contacts used in specific circular connectors and the applicable insertion/extraction tool.

400.3.10 Spare contacts. When crimp contact connectors are used, the unused contacts shall be installed. Sealing plugs shall be inserted in unused grommet holes of environment-resisting connectors. For potted connectors, each spare contact shall have a pigtail attached, consisting of a wire 5 to 7 inches long of the largest size that can be accommodated by the contact. The pigtails shall be identified and dead ended.

TABLE XIII. MIL-C-5015 connector contacts.

MIL-C-39029/	Pin or socket	Contact size	Connector used with (standard)	Insertion/extraction tools
29	P	16, 12, 8, 4, 0	MS3450 Series	8, 4, and 0 size contacts, use MIL-I-81969/29. 16 and 12 size contacts, use MIL-I-81969/14.
30	S	16, 12, 8, 4, 0	MS3450 Series	
44	P	16, 12, 8, 4, 0	MS3400 Series	
45	S	16, 12, 8, 4, 0	MS3400 Series	
85	P	16, 12	MS3450 Series	
86	S	16, 12	MS3450 Series	

MIL-STD-339(AT)
 SECTION 400
 CONNECTORS

TABLE XIV. MIL-C-26482 and MIL-C-83723 connector contacts.

MIL-C-39029/	Pin or socket	Contact size	Connector used with (Specification)	Insertion/extraction tools
4	P	20, 16, 12	MIL-C-26482 Series II MIL-C-83723 Series III	MIL-I-81969/30 MS27534
5	S	20, 16, 12		
7	P	Shielded 12		
8	S	Shielded 12		
9	P	Thermocouple 20		
10	S	Thermocouple 20		
23	P	Shielded 8	MIL-C-26482 Series I	MIL-I-81969/17 and 18
24	S	Shielded 8		
25	P	Shielded 12		
26	S	Shielded 12		
31	P	20, 16, 12		
32	S	20, 16, 12		
73	S	Shielded 12	MIL-C-83723 Series III	MIL-I-81969/30 MS27534
74	P	Shielded 12		

MIL-STD-339(AT)
SECTION 400
CONNECTORS

TABLE XV. MIL-C-38999 connector contacts.

MIL-C-39029/	Pin or socket	Contact size	Connector used with (specification)	Insertion/extraction tool
27	S	Shielded 12	Series II	MIL-I-81969/14 MS27534
28	P	Shielded 12		
56	S	22, 20, 16, 12	Series I	
57	S	22	Series II	
58	P	22, 20, 16, 12	Series I & II	
59	S	Shielded 8	Series II	
60	P	Shielded 8		
71	P	22	Series II	
72	S	22		
75	S	Shielded 12	Series I	
76	P	Shielded 16	Series I & II	
77	S	Shielded 16	Series I	
78	S	Shielded 16		
87	P	22, 20, 16	Series I & II	
88	S	22, 20, 16	Series I	
89	S	22, 20, 16	Series II	

400.3.11 Solder-type contacts. The soldering of contacts shall be in accordance with MIL-STD-454, requirement 5. When a brazing process is used, it shall be in accordance with MIL-B-7883.

400.3.12 Crimp technique. Compression crimping is a method for joining an electrical conductor (wire) to another current-carrying member (contact). The method includes the use of a tool to compress the member tightly onto the conductor wire. The compressed juncture is called the crimp joint. A proper crimp joint is electrically sound and mechanically strong. External heat is not utilized, so there is no damage to insulation or to small conductors. Degradation of the crimp joint due to shock or vibration is practically eliminated by using insulation grip/support as an integral part of the

MIL-STD-339(AT)

SECTION 400

CONNECTORS

contact. A good crimp termination is defined as one in which the mechanical connection of the wire and the contact does not break or become distorted before the minimum specified tensile strength is reached (see table XVI). Where there are no specified tensile values for specific crimp termination, it is common practice to set the requirement at 75 percent of the minimum allowable tensile strength of the wire. Crimping is the dominant method for wire termination for the following reasons:

- a. The crimped joints can be stronger than the wire itself.
- b. The human element is virtually eliminated, since the overall reliability is controlled by the crimping tool, not the operator.
- c. Crimping is fast and easy, and tools are uncomplicated and inexpensive.
- d. Terminations can be repaired or modified in the field exactly as in the factory using the same tools and techniques.
- e. Viewing the wire through an inspection hole in the contact makes visual inspection quick, easy, and sure, by both the operator and the inspector.

400.3.12.1 Crimp tools. Contractors may use automatic, semiautomatic, or hand-crimp tools for production, provided contacts will give specified performance in accordance with MIL-C-22520 when crimped with the applicable tool.

400.4 QUALITY ASSURANCE PROVISIONS

400.4.1 Inspections. Inspections shall be performed in accordance with the applicable military specification or drawing.

400.5 PACKAGING

400.5.1 Preservation, packaging, packing, and marking. Preservation, packaging, packing, and marking for the desired level shall be in accordance with the applicable drawing or packaging requirements specified by the contracting authority.

400.6 NOTES

400.6.1 Definitions.

400.6.1.1 Bayonet coupling. A quick-coupling device for plug and receptacle connectors, accomplished by rotation of a cam-operating device designed to bring the connector halves together.

400.6.1.2 Connector. Any device used to provide rapid connect/disconnect service for electrical cable and wire terminations.

400.6.1.3 Contacts. The conducting members of a connecting device which are designed to provide a separable connection in a cable-to-cable, cable-to-box, or a box-to-box connection.

**SECTION 400
 CONNECTORS**

TABLE XVI. Tensile strength of crimped contacts.

Mating end size	Wire barrel size	Wire size (AWG #)	Axial load (pounds)							
			Silver, tin-plated copper wires		Nickel-plated copper wire		Thermal condition values			
			Initial condition values	Thermal condition values	Initial condition values	Thermal condition values	Initial condition values	Thermal condition values		
0	0	0 2 <u>1/</u>	700	550	630.0	495.0	630	495	567.0	445.5
0	1	1 2 <u>1/</u>	650	550	585.0	495.0	585	495	526.5	445.5
2	2	2 4 <u>1/</u>	550	400	495.0	360.0	495	360	445.5	324.0
4	4	4 6 <u>1/</u>	400	300	360.0	270.0	360	270	324.0	243.0
6	6	6 8 <u>1/</u>	300	200	270.0	198.0	270	200	243.0	180.0
8	8	8 10 <u>1/</u>	220	150	198.0	135.0	200	135	180.0	121.5
10	10	10 12 <u>1/</u>	150	110	135.0	99.0	135	100	121.5	90.0
12	12	12 14	110	70	93.0	61.0	100	60	85.0	53.0
16	16	16 20	50	20	45.0	14.0	37	19	33.3	14.3
20	20	20 24	20	8	14.0	6.0	19	6	14.3	4.5
22	22	22 26	12	5	7.5	4.0	8	3	6.0	2.5
22	22D	22 28	12	3	7.5	2.25	8	2	6.0	1.5
22	22M <u>2/</u>	24 28	8	3	6.0	2.25	6	2	4.5	1.5

1/ With electrically conductive bushing.
2/ Inactive for new design.

MIL-STD-339(AT)

SECTION 400

CONNECTORS

400.6.1.4 Contact retention. The maximum axial load in either direction which a contact must withstand while remaining firmly fixed in its normal position within an insert.

400.6.1.5 Contact size. The largest size wire which can be used with a specific contact. By specification dimensioning, it also defines the diameter of the engagement end of the pin.

400.6.1.6 Contact spacing. The distance between the centers of contacts within an insert.

400.6.1.7 Coupling ring. A device used on cylindrical connectors to lock plug and receptacle together.

400.6.1.8 Face seal. That design feature which fills the voids between the faces of plug and receptacle when they are fully engaged. This provides an environmental seal between the faces of the plug and receptacle and also increases the dielectric between contacts which can increase the service rating of the connector.

400.6.1.9 Flange. A projection extending from, or around, the periphery of a connector and providing holes to permit mounting the connector to a panel or to another mating connector half.

400.6.1.10 Grommet. A rubber seal used on the cable side of a multiple-contact connector to seal the connector against moisture, dirt, and air.

400.6.1.11 Insert. That part which holds the contacts in their proper arrangement and electrically insulates them from each other and from the shell.

400.6.1.12 Plug. The part of the two mating halves of a connector which is free to move when not fastened to the other mating half. The plug is usually thought of as the male portion of the connector. This is not always the case. The plug may have female contacts if it is the "free to move" member.

400.6.1.13 Polarization. A mechanical arrangement of inserts and/or shell configuration (referred to as clocking in some instances) which prohibits the mating of mismatched plugs and receptacles. This is to allow connectors of the same size to be lined up, side by side, with no danger of making wrong connection. Coded arrangements of contact, keys, keyways, and insert positions are used.

400.6.1.14 Receptacle. Usually the fixed or stationary half of a two-piece, multiple-contact connector. Also the connector half usually mounted on a panel and containing socket contacts.

400.6.1.15 Shell. Outside case into which the insert and contacts are assembled. Shells of mating connectors usually also provide proper alignment and protection of projecting contacts.

500.1 SCOPE

500.1.1 Scope. This section covers the material selection for connector accessory hardware.

500.2 APPLICABLE DOCUMENTS

500.2.1 Government documents.

500.2.1.1 Specifications and standards. The following specifications and standards form a part of this standard to the extent specified herein. Unless otherwise specified, the issues of these documents shall be those listed in the issue of the Department of Defense Index of Specifications and Standards (DODISS) and supplement thereto, cited in the solicitation.

SPECIFICATIONS

MILITARY

- | | |
|-------------|---|
| MIL-C-5015 | - Connectors, Electrical, Circular Threaded, AN Type, General Specification for. |
| MIL-C-26482 | - Connectors, Electrical, Circular, Miniature, Quick-Disconnect Environment Resistant, Receptacles and Plugs, General Specification for. |
| MIL-C-38999 | - Connectors, Electrical, Circular, Miniature, High Density, Quick Disconnect (Bayonet, Threaded, and Breech Coupling), Environment Resistant, Removable Crimp and Hermetic Solder Contacts, General Specification for. |
| MIL-I-81765 | - Insulating Components, Molded, Electrical, Heat Shrinkable, General Specification for. |
| MIL-C-83723 | - Connector, Electric, Circular, (Environment-Resisting), Receptacles and Plugs, General Specification for. |

STANDARDS

MILITARY

- | | |
|--------|--|
| MS3109 | - Boots, Heat-Shrinkable, Strain-Relief, Straight. |
| MS3117 | - Boots, Heat-Shrinkable, Strain-Relief, Right Angle. |
| MS3152 | - Strain Relief, Straight, for Electrical Connectors. |
| MS3153 | - Strain Relief, 45°, for Electrical Connectors. |
| MS1354 | - Strain Relief, 90°, for Electrical Connectors. |
| MS3155 | - Connector, Electric, Rear Accessory, Design Standard. |
| MS3158 | - Backshells, Heat-Shrinkable Boot, for Electrical Connectors. |

MIL-STD-339(AT)
SECTION 500
CONNECTOR ACCESSORY HARDWARE

MS3188	- Backshell, 90°, Cable Sealing and Shield Termination, Connector, Electric.
MS3189	- Backshell, 45°, Cable Sealing and Shield Termination, Connector, Electric.
MS3415	- Clamps, Strain Relief, 45°, for Electric Connectors.
MS3416	- Backshells, Straight, for Electric Connectors.
MS3417	- Clamps, Strain Relief, Straight, for Electric Connectors.
MS3418	- Clamps, Strain Relief, 90°, for Electric Connectors.
MS3419	- Backshells, Shield Termination, for Electric Connectors.
MS25043	- Cover, Electrical Connector, Receptacle, AN Type.
MS90376	- Caps, Dust, Plastic, Electric Connector.

(Copies of specifications, standards, handbooks, drawings, publications, and other Government documents required by the contractors in connection with specific acquisition functions should be obtained from the contracting activity or as directed by the contracting activity.)

500.2.2 Other publications. The following documents form a part of this standard to the extent specified herein. Unless otherwise specified, the issues of the documents which are DOD adopted shall be those listed in the issue of the DODISS specified in the solicitation. Unless otherwise specified, the issues of documents not listed in the DODISS shall be the issue of the nongovernment documents which is current on the date of the solicitation.

AEROSPACE INDUSTRIES ASSOCIATION OF AMERICA, INC.

NAS 813	- Cap - Protective, Electrical Connector.
NAS 820	- Plug - Protective, Electrical Connector.

(Applications for copies should be addressed to Aerospace Industries Association of America, Inc., 1725 DeSales Street, NW, Washington, DC 20036.)

(Nongovernment standards and other publications are normally available from the organizations which prepare or which distribute the documents. These documents also may be available in or through libraries or other informational services.)

500.2.3 Order of precedence. In the event of a conflict between the text of this standard and the references cited herein, the text of this standard shall take precedence.

MIL-STD-339(AT)
SECTION 500
CONNECTOR ACCESSORY HARDWARE

500.3 REQUIREMENTS

500.3.1 Introduction. Accessories are devices which supplement the basic connector to adapt it to each unique application. Some of the more commonly used accessories will be discussed in the following paragraphs.

500.3.2 Boots. Boots come in two categories. In the first category, they are used as a potting cup. In this application, the boot is used as a mold in potting the region between the rear of the insert and the breakout of the cable or wire bundle. In some cases, the potting-cup boot is discarded after potting; in others it becomes a part of the shell. This application lends itself to wiring harness types. In the second application, the boot is used to prevent the entry of moisture into the rear of a connector. A series of heat-shrinkable boots are available in straight (MS3109) and right angle (MS3117) configurations per MIL-I-81765. Heat-shrinkable boots are supplied in two temperature ranges: -55°C to $+135^{\circ}\text{C}$ and -55°C to $+200^{\circ}\text{C}$. Also available are backshells (MS3158) for use with heat-shrinkable boots which provide the means for attaching the boots.

500.3.3 Strain relief. Connector accessories, such as strain-relief clamps and backshells, shall be parts specifically approved for the connector and shall conform to the requirements of the related connector specification.

Strain relief clamps are available in straight (MS3417), 45° (MS3415), and 90° (MS3418) configurations. These configurations shall conform to MS3155 and are generally used on MIL-C-5015 connectors. Strain relief units for MIL-C-5015 (crimp), MIL-C-26482, and MIL-C-83723 connectors are available in straight (MS3152), 45° (MS3153), and 90° (MS3154) configurations. The configurations shall conform to MS3155. Straight backshells for use on MIL-C-5015 connectors may be obtained per MS3416. Connectors requiring shield terminations and cable sealing shall use MS3419 (straight), MS3139 (45°), and MS3188 (90°) backshells. All configurations shall conform to MS3155.

500.3.4 Dust caps. After fabrication and throughout production, unmated connectors shall be capped to prevent damage to the contacts and entry of foreign matter. Dust caps for MIL-C-5015 connectors shall be selected from NAS 813 and NAS 820. Dust caps for MIL-C-5015, MIL-C-26482, MIL-C-38999, and MIL-C-83723 connectors shall be selected from MS90376.

500.3.5 Protective covers. Connectors intended for test plugs and for future wiring or mating shall be capped with captive, vapor-tight protective covers engaging with the connector coupling feature. Connectors for optional wiring shall be provided with captive protective covers unless mated to dummy receptacles. A dummy stowage receptacle shall be installed near each unmated connector, for storing covers when the connector is in use. Dummy stowage receptacles shall be conspicuously identified as being dummies used for stowage of protective covers. Protective covers for MIL-C-5015 connectors shall be selected from MS25043.

MIL-STD-339(AT)

SECTION 500

CONNECTOR ACCESSORY HARDWARE

500.3.6 Provision plugs. Connector plugs which are for equipment to be installed later or for test purposes shall be secured by clamps, or to dummy receptacles provided for that purpose, in order that the plug cannot swing on wiring and cause damage to itself, wiring, or adjacent equipment, or foul mechanical linkages.

500.3.7 Dummy receptacles. Dummy receptacles shall have an integral key(s) to prevent rotation of the mating plug.

500.4 QUALITY ASSURANCE PROVISIONS

500.4.1 Inspections. Inspections shall be performed in accordance with the applicable military specification or drawing.

500.5 PACKAGING

500.5.1 Preservation, packaging, packing, and marking. Preservation, packaging, packing, and marking for the desired level shall be in accordance with the applicable drawing or packaging requirements specified by the contracting authority.

500.6 NOTES

500.6.1 Definitions.

500.6.1.1 Accessories. Mechanical devices, such as cable clamps, added to connector shells and other such hardware which are attachable to connectors to make up the total connector configuration.

500.6.1.2 Adapter. An intermediate device which accomplishes the attachment of special accessories and provides for special mounting.

500.6.1.3 Boot.

- a. Protective covering over any portion of a cable, wire, or connector in addition to the normal jacketing or insulation.
- b. A form placed around wire termination of a multiple-contact connector to contain the liquid potting compound before it hardens.
- c. A protective housing usually made from a resilient material to prevent entry of moisture into a connector.

500.6.1.4 Cover (dust cap). An item specifically designed to cover the mating end of a connector for mechanical and environmental protection.

500.6.1.5 Dummy connector, receptacle. An item specifically designed to mate with a plug connector to perform one or more special functions. It does not have provisions for attaching a cable. Dummy receptacles normally have no inserts or contacts present and are usually simple receptacle shells.

MIL-STD-339(AT)
SECTION 500
CONNECTOR ACCESSORY HARDWARE

500.6.1.6 Potting. Sealing of a component (e.g., the cable end of a multiple-contact connector) with a plastic compound or material to exclude moisture, prevent short circuits, and provide strain relief.

500.6.1.7 Potting cup. An accessory which, when attached to the rear of a plug or receptacle, provides a pouring form for potting the wires at the wire entry end of the assembly.

500.6.1.8 Strain-relief clamp. An adjustable collar, usually secured by a nut and bolt, that clamps the wire or cable attached to the connector so as to relieve the strain on the contact terminations.

WIRING HARNESSSES, MOLDED CABLE ASSEMBLIES,
HYBRID CABLE ASSEMBLIES, AND
CONVOLUTE TUBING CABLE ASSEMBLIES

600.1 SCOPE

600.1.1 Scope. This section defines the fabrication methods and techniques used to design and build wiring harnesses, molded cable assemblies, hybrid cable assemblies, and convolute tubing cable assemblies.

600.2 APPLICABLE DOCUMENTS

600.2.1 Government documents.

600.2.1.1 Specification and standards. The following specification and standards form a part of this standard to the extent specified herein. Unless otherwise specified, the issues of these documents shall be those listed in the issue of the Department of Defense Index of Specifications and Standards (DODISS) and supplement thereto, cited in the solicitation.

SPECIFICATION
MILITARY

MIL-W-16878 - Wire, Electrical, Insulated, General Specification for.

STANDARDS
MILITARY

MIL-STD-104 - Limits for Electrical Insulation Color.
MIL-STD-454 - Standard General Requirements for Electronic Equipment.
MIL-STD-681 - Identification Coding and Application of Hookup and Lead Wire.
MIL-STD-686 - Cable and Cord, Electrical; Identification Marking and Color Coding of.
MS21980 - Ferrules, Outer, Uninsulated, Shield Terminating, Type I Two-Piece, Class I, for Shielded Cable.
MS21981 - Ferrule, Inner, Uninsulated, Shield Terminating, Type I Two-Piece, Class I, for Shielded Cable.

(Copies of specifications, standards, handbooks, drawings, publications, and other Government documents required by the contractors in connection with specific acquisition functions should be obtained from the contracting activity or as directed by the contracting activity.)

600.2.2 Other publications. The following documents form a part of this standard to the extent specified herein. Unless otherwise specified, the issues of the documents which are DOD adopted shall be those listed in the issue of the DODISS specified in the solicitation. Unless otherwise specified, the issues of documents not listed in the DODISS shall be the issue of the nongovernment documents which is current on the date of the solicitation.

WIRING HARNESSSES, MOLDED CABLE ASSEMBLIES,
HYBRID CABLE ASSEMBLIES, AND
CONVOLUTE TUBING CABLE ASSEMBLIES

AEROSPACE INDUSTRIES ASSOCIATION OF AMERICA, INC.

- NAS 1744 - Splice, Conductor, Solder Style, Hot Air or Infrared Shrinkable, Insulated, Immersion Resistant.
- NAS 1745 - Splice, Shield Termination, Solder Style, Hot Air Shrinkable, Insulated, Moisture Resistant.
- NAS 1746 - Splice, Shield Termination, Solder Style, Infrared Shrinkable, Insulated, Moisture Resistant.
- NAS 1747 - Splice, Conductor and Shield Termination, Solder Style, Heat Shrinkable, Insulated, Specification for.

(Applications for copies should be addressed to Aerospace Industries Association of America, Inc., 1725 DeSales Street, NW, Washington, DC 20036.)

(Nongovernment standards and other publications are normally available from the organizations which prepare or which distribute the documents. These documents also may be available in or through libraries or other informational services.)

600.2.3 Order of precedence. In the event of a conflict between the text of this standard and the references cited herein, the text of this standard shall take precedence.

600.3 REQUIREMENTS

600.3.1 Introduction. Electrical interconnection systems are the means used to route signal and power voltages to various subassemblies and units of a piece of equipment. In addition to the various types of conductors used to meet electrical requirements, the interconnection system includes terminals, connectors, and mounting hardware. Depending on the complexity of the equipment or the environmental requirements, the electrical interconnection design may be selected from several fabrication methods.

600.3.2 Terminology, cable. A multiconductor cable may be interpreted as two or more conductors in any one complex. The description specified in tables XVII and XVIII will apply throughout this text.

MIL-STD-339(AT)

SECTION 600

**WIRING HARNESSES, MOLDED CABLE ASSEMBLIES,
 HYBRID CABLE ASSEMBLIES, AND
 CONVOLUTE TUBING CABLE ASSEMBLIES**
TABLE XVII. Multiconductor cable symbols.

Number of conductors	Description	Symbol
1	Single conductor	SC
2	Two conductors	TP
3	Three conductors	TT
4	Four conductors	TQ
5	Five conductors	T5
6	Six conductors	T6
etc.	etc.	etc.

If a shield is added to any component listed above, the following will apply:

TABLE XVIII. Multiconductor shielded cable symbols.

Number of conductors	Description	Symbol
1	Single cond. shield & jacket	SSJ
2	Two cond. shield & jacket	TPSJ
3	Three cond. shield & jacket	TTSJ
4	Four cond. shield & jacket	TQSJ
5	Five cond. shield & jacket	T5SJ
6	Six cond. shield & jacket	T6SJ
etc.	etc.	etc.

The AWG number is inserted before the symbol to denote wire size, e.g., 20SSJ, 22TPSJ, etc.

The number of individual components within a cable design is inserted before the AWG number followed by a (/), e.g., 20/20SSJ, 4/22TPSJ, etc. This will define the quantity, size, and configuration of each wire and/or cable within a multiconductor cable.

600.3.3 Wiring harnesses. A wiring harness is a group of conductors laid parallel or twisted by hand, usually with many breakouts, laced or bundled together or pulled into a rubber or plastic sheath, used to interconnect electrical circuits.

The first consideration for any wiring harness or cable assembly is an assessment of the current requirements within the system being designed. Upon establishment of the current requirements, wire sizes can be selected (see section 100).

SECTION 600

WIRING HARNESES, MOLDED CABLE ASSEMBLIES,
HYBRID CABLE ASSEMBLIES, AND
CONVOLUTE TUBING CABLE ASSEMBLIES

The second consideration is any critical voltage requirement as related to total length of wire run (so called I.R. drop) current versus resistance drop due to length and possibly temperature increase.

When total wire size and quantity are known, one should assess the environmental and mechanical requirements of the system. From this assessment, an appropriate military wire specification may be selected. The next step would be the selection of the correct connector and its insert arrangement for each interconnection or piece of equipment (see section 400).

Fabrication of wiring harnesses is accomplished on layout boards containing pegs or nails strategically placed for routing individual wires (see figure 2). Individual wires or groups of wires are routed between the nails from a specific connector location per a wire schematic on the layout board. This task is accomplished for each connector or terminal until all conductors required have been routed.

Multiple conductors are contained in a bundle by a variety of means. Originally, wires were tied together by lacing cord, string, or tape. Although these methods are still feasible in breadboard applications and in relatively uncomplicated wiring systems, labor costs become significant in more complex equipment. In this case, a more economical solution might first be sought in spiral-cut plastic cable-wrapping material. This method additionally provides a degree of resistance to abrasion, while retaining conductor breakout capability. Spiral cable wrap is typically available in polyethylene, nylon, Teflon, and flame-retardant polyethylene. Connector termination on wiring harnesses is mostly solder type and soldering is accomplished per MIL-STD-454, requirement 5. This standard establishes the flux and solder to be used and defines the stripping, cleaning, and pretinning requirements. When connector termination is crimp type, the crimp information is available from the connector manufacturer or the military standard, drawing, or specification. Wire lengths at the connector are purposely left longer than required to provide sufficient termination lengths for soldering or crimping. Connector termination and orientation is accomplished on the layout board completing the wiring harness.

As the complexity and quantity of the wiring harnesses increase, the fabrication technique changes from a layout board to a computerized automatic harness forming machine to run multiple wires throughout complex routing paths. These systems use an X - Y positioner mounted over the forming board. After the program is inserted into the controller, the machine sequentially selects a wire, runs it through the specified path, cuts it, and returns for another wire. After the wiring harness is complete, it is tied.

Wiring harness fabrication is less costly than other cable methods due to a minimum amount of labor hours required and material acquisition is minimal for usually low-cost items. The greatest disadvantage of wiring harness design is the incapability to protect the wire insulation from abrasion and the assembly from environmental elements, especially at the connectors. Wiring harness design should be considered concurrently with the mechanical design of a product to avoid last minute and costly concessions in either area.

MIL-STD-339(AT)
SECTION 600
WIRING HARNESSES, MOLDED CABLE ASSEMBLIES,
HYBRID CABLE ASSEMBLIES, AND
CONVOLUTE TUBING CABLE ASSEMBLIES

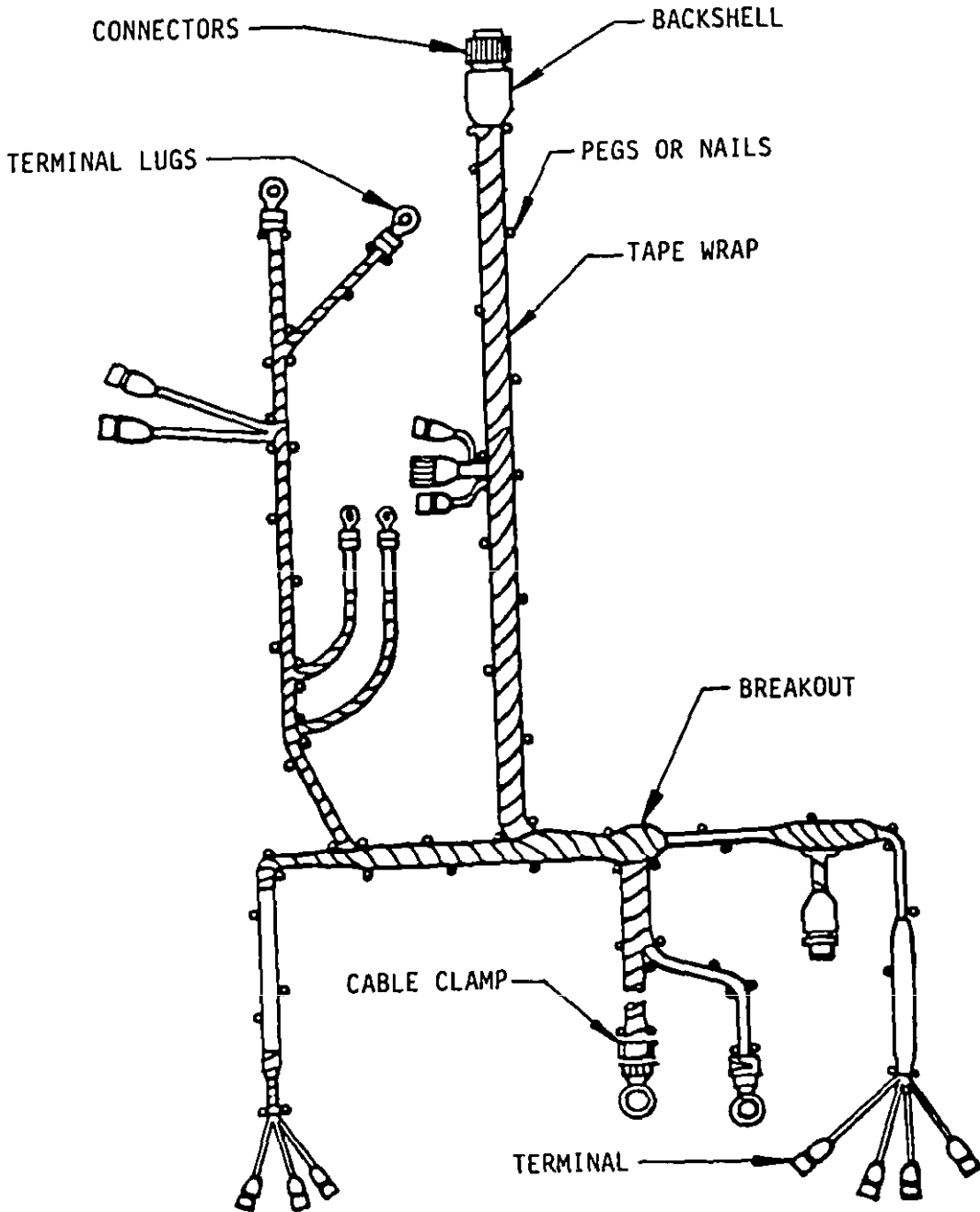

FIGURE 2. Wiring harness.

SECTION 600

WIRING HARNESSSES, MOLDED CABLE ASSEMBLIES,
HYBRID CABLE ASSEMBLIES, AND
CONVOLUTE TUBING CABLE ASSEMBLIES

600.3.4 Molded cable assemblies. Molded cable assemblies (see figure 3) are completely sealed units and therefore provide protection to the individual wires and cables. Additionally, the termination of wire at the connector is encapsulated in the molding compound preventing moisture entry at the rear of the connector and the compound provides extra benefits as a strain relief.

The cabling, or twisting, operation is a very important function. Its primary effects are felt in the mechanical performance of the cable. In the design of a multiconductor complex, the conductors should be so arranged in the overall design that a flexible, circular cross section, with the smallest possible overall diameter, will be obtained. The planetary-type cabling or twisting machine keeps all components in the same plane and eliminates any twisting action of the individual components of a complex. In order to function properly, the core must consist of conductors and fillers which work together over a wide temperature range and under extreme mechanical stress. The basic materials of which the insulation and fillers are made must have low coefficients of friction so that they do not tend to adhere during cable flexing. The ease of slippage changes cable limpness, improves cable life under mechanical stress, prevents frictional heating, and reduces wear on insulation. Fillers must maintain position and not reduce in diameter (pack) during service. The following factors should be considered in designing a cable:

- a. Where cables consist of mixed conductor sizes and element construction (shielded pairs, coaxes, etc.), it is generally advantageous to place the larger elements in the center or core of the cable. This allows the larger conductors to carry a greater portion of the cable tensile stress. This is due, in part, to the shorter lay length (see 600.3.5). Coaxes should not be placed in the center (core) of the cable. This is not always possible but should be avoided.
- b. A single wire, with or without shield, should not be placed in the center of the core if possible, as this wire is a straight line pin to pin (has no lay length) and cannot adjust its length when flexed.
- c. While fillers may be used in any layer in place of a conductor, it is best economy to put fillers in the outer layer if possible.

WIRING HARNESES, MOLDED CABLE ASSEMBLIES,
HYBRID CABLE ASSEMBLIES, AND
CONVOLUTE TUBING CABLE ASSEMBLIES

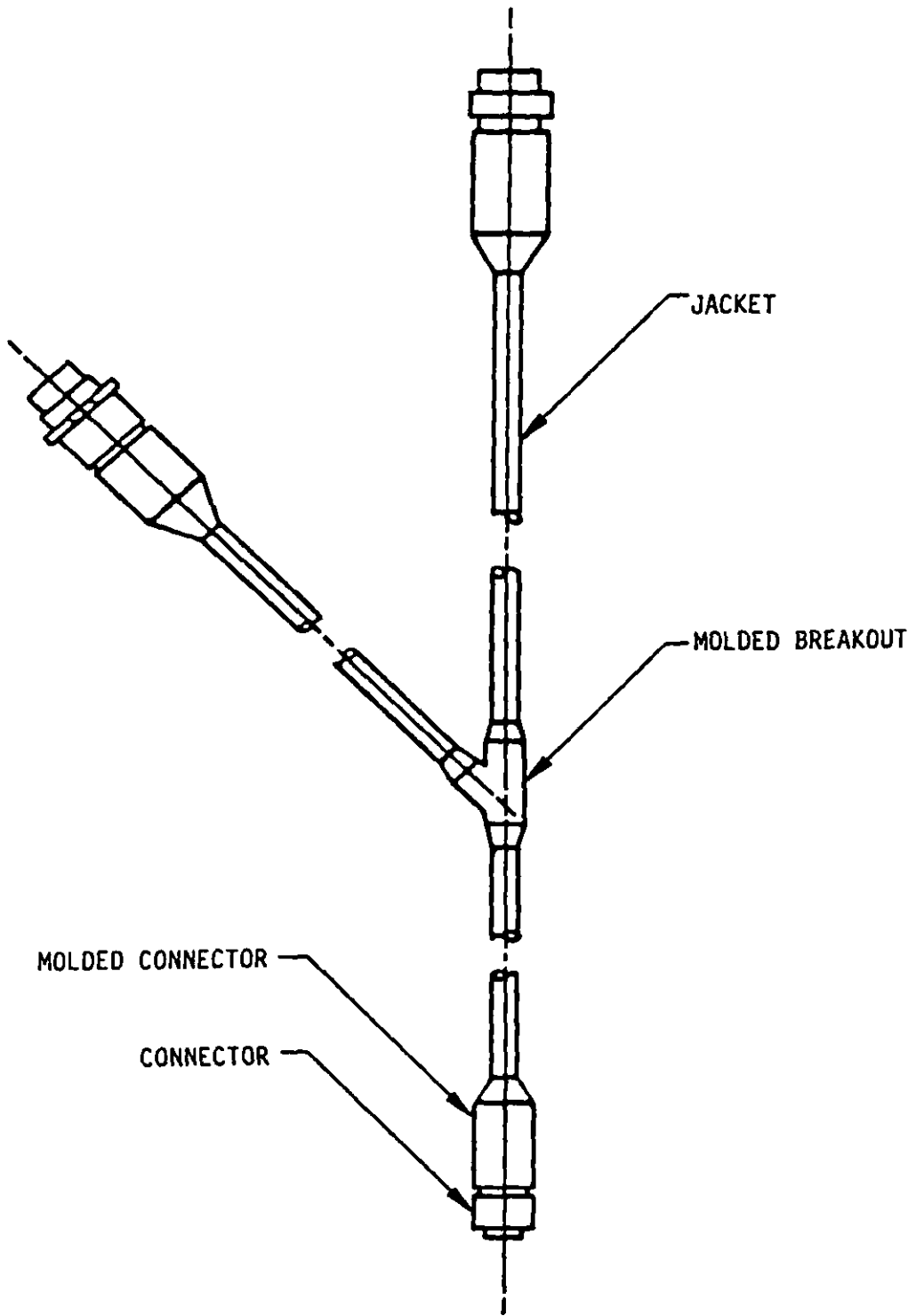

FIGURE 3. Molded cable assembly.

WIRING HARNESES, MOLDED CABLE ASSEMBLIES,
HYBRID CABLE ASSEMBLIES, AND
CONVOLUTE TUBING CABLE ASSEMBLIES

- d. Twisted pairs tend to compact (nest) and, therefore, an additional reduction in core diameter can be realized. The reduction varies slightly but is normally 12 percent.
- e. Tape wraps should be used over and under the metallic braid (shield) to prevent abrasion damage and piercing of insulation by broken strands. Tape wraps may be used between layers to hold conductors in place. Tapes should be selected for the same environments as the wire and outer jacket.

600.3.5 Lay. In the design of a cable complex, cabling lay length is important. "Cable lay length" is the distance of advance, measured axially, of one turn of any one component within the cabled group. For good cable design, lay length should be 8 to 12 times the layer diameter.

NOTE: Wired pairs, triads, etc. are twisted or layed at 8 to 16 times the diameter and are not to be confused with cable design. The longer the lay length, the stiffer the cable and, conversely, the shorter the lay length, the more flexible the cable becomes. Lay length may be decreased to complete a layer which would normally require a filler. As a general rule, 10 times the layer diameter is generally used for the lay length, as this lay length gives the best economy and flexibility.

600.3.6 Color coding. The use of color coding in a cable is frequently required for circuit identification. However, color coding has one serious drawback in that as coded wires must be terminated into a specific contact location as one progresses through the total pin configuration, crossovers occur which cause excessive buildup at the rear of the connector. This buildup is repeated at the opposite end as well. Color coding is also more costly and time consuming; if wires are uncoded, one must only select the correct wire size and terminate one end; the other end is terminated by buzzing to find each circuit. As military requirements sometimes make color coding mandatory, a short discussion of types and methods follows:

- a. Color coding the primary dielectric or jacket using colored compounds.
- b. Single solid-color extrusion, usually white, and then ink striping, using vari-colored, spiral, longitudinal, or hashmark stripes.
- c. Where textile braids are used, multi-colored textile strands or carriers are woven into a colored stripe.
- d. The use of printed words or numbers to denote the color desired.

WIRING HARNESSES, MOLDED CABLE ASSEMBLIES,
HYBRID CABLE ASSEMBLIES, AND
CONVOLUTE TUBING CABLE ASSEMBLIES

- e. The use of a worded or numbered tape, applied spirally or longitudinally to the primary dielectric, or under the shield or sheath.

600.3.6.1 Striping method. When using the striping method of color coding, the stripe sequence is designated as follows: A "base stripe," or wide stripe. The second stripe (narrower than the first or base stripe) and successive stripes until code is complete. These secondary stripes are called tracer stripes.

600.3.6.2 Color code and related numbers. Some military wire specifications use letters for color coding; others use numbers. Table XIX shows the relationship between these symbols.

The standards used on wire for military use are MIL-STD-104, MIL-STD-681, and MIL-STD-686 (included here for reference and additional information).

TABLE XIX. Color coding.

Color No.	Color	Abbreviation
0	Black	Blk
1	Brown	Brn
2	Red	Rd
3	Orange	Orn
4	Yellow	Yel
5	Green	Grn
6	Blue	Blu
7	Violet	Vio
8	Gray	Gry
9	White	Wht

600.3.7 Cable binders - separators. When twisting components or groups of components together into a completed cable over which an outer shield or sheath is to be placed, it is important for this core to be held together so (1) the original cable shape will be preserved, (2) electrical properties of the component groups will not be disturbed, and (3) the outer extruded sheath material will not adhere to the inner components, making the cable nearly inflexible and very difficult to strip for termination. This material or layer is called a binder or separator, and may be applied in various methods. The most common method utilizes a tape which must be of a material which is compatible with both the cable components and the outer sheathing material. The more common tapes used for this purpose are polyethylene terephthalate (MYLAR), polyvinyl chloride (PVC), polyethylene, Teflon, polypropylene, silicone-impregnated glass, PVC-impregnated cotton, laminated Mylar and aluminum, and Teflon-impregnated glass. Depending upon the cable construction and/or cable requirements, this tape is usually helically wound with the overlap from 75 percent to open. The most common tape wrap utilizes a 50-percent overlap. The percent overlap is determined as the amount the

MIL-STD-339(AT)
 SECTION 600
 WIRING HARNESSSES, MOLDED CABLE ASSEMBLIES,
 HYBRID CABLE ASSEMBLIES, AND
 CONVOLUTE TUBING CABLE ASSEMBLIES

leading edge of one wrap overlaps the trailing edge of the preceding wrap, expressed as a percent of tape width. A butt wrap is where the trailing edge of one wrap just meets the leading edge of the preceding wrap, giving 100 percent coverage, but not overlap. An open wrap is where a space is left between the trailing and leading edges of the tape, giving less than 100 percent coverage. Another application method of a binder or separator is to use a fibrous, woven, or braided material such as cotton, nylon, or glass. In some instances, this method is required because of the rough surface formed by the woven or braided binder.

600.3.8 Lay pattern development. The fabrication method used to accomplish this type of cable starts by establishing a lay pattern for all the conductors used. The lay pattern (see figure 4) arranges the conductors to obtain uniformity, maximum flexibility, and minimum diameter. This is best accomplished by placing the larger conductors and twisted complexes in or near the cable core with the smaller conductors in the outer layers. Where this is found to be impractical due to variables involved, it may be necessary to place large conductors in the outer periphery and in other instances small conductors may be roped to obtain uniformity and flexibility. Cable lays may be contrahelical (each layer wound in the opposite direction of the preceding layer) or unidirectional (one direction-pitch varied). Direction of lay may be either right or left handed and is defined as the direction of a conductor layer, either clockwise or counterclockwise. Filler material may be in the form of extruded rod, multiple filaments, or fibrous materials.

Tapes are applied as a spiral wrap over the completed cable core to maintain conductor placement during subsequent operations. Tape is also used as a barrier between conductors and jacket. Table XX is an example of a typical multiconductor cable.

TABLE XX. Multiconductor cable.

Quantity	Size/Type	Maximum diameter
3	20TQ SJ	.180
13	16SSJ	.115
37	20SC	.058

All wire per MIL-W-16878/4.

600.3.9 Calculation. The following calculations follow the necessary step by step method for evolving a cable lay pattern. The first step is to multiply the diameter of the wires in the core by the factor listed in table XXI: $3/20TQ SJ (.180) \times 2.15 = .387$ which is the core diameter. The next step is to divide the core diameter by the diameter of the next selected wire size; i.e., in this case 16SSJ (.115).

WIRING HARNESSES, MOLDED CABLE ASSEMBLIES,
 HYBRID CABLE ASSEMBLIES, AND
 CONVOLUTE TUBING CABLE ASSEMBLIES

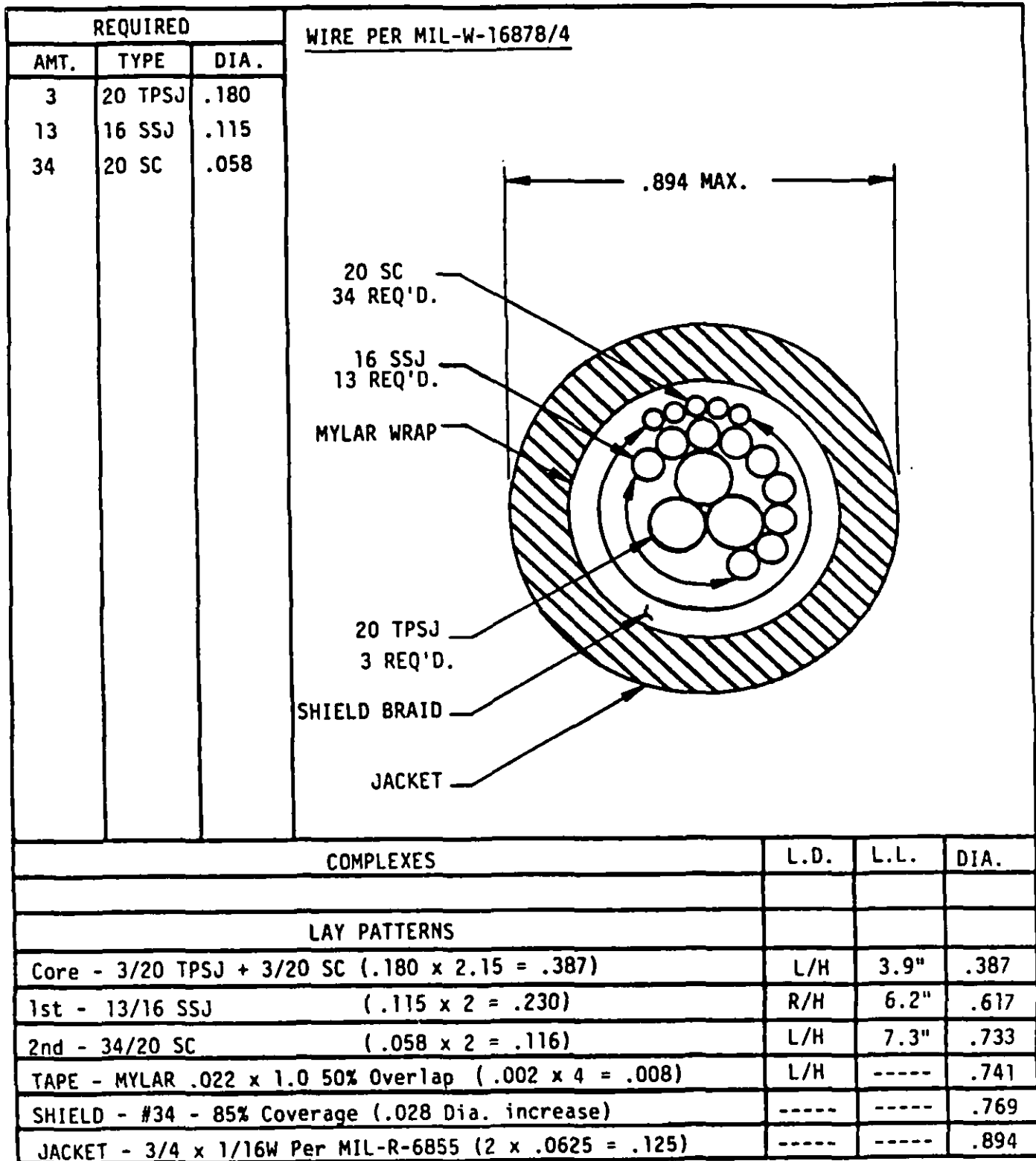

FIGURE 4. Lay pattern.

WIRING HARNESSSES, MOLDED CABLE ASSEMBLIES,
HYBRID CABLE ASSEMBLIES, AND
CONVOLUTE TUBING CABLE ASSEMBLIES

TABLE XXI. Lay pattern calculations.

NUMBER OF LAYERS	1 IN CENTER			2 IN CENTER			3 IN CENTER			4 IN CENTER			5 IN CENTER		
	NUMBER OF WIRES IN LAY	TOTAL NO. OF WIRES IN CABLE	MULTIPLY WIRE DIA. BY	NUMBER OF WIRES IN LAY	TOTAL NO. OF WIRES IN CABLE	MULTIPLY WIRE DIA. BY	NUMBER OF WIRES IN LAY	TOTAL NO. OF WIRES IN CABLE	MULTIPLY WIRE DIA. BY	NUMBER OF WIRES IN LAY	TOTAL NO. OF WIRES IN CABLE	MULTIPLY WIRE DIA. BY	NUMBER OF WIRES IN LAY	TOTAL NO. OF WIRES IN CABLE	MULTIPLY WIRE DIA. BY
1	1	1	$dx1$	2	2	$dx2$	3	3	$d \times 2.15$	4	4	$dx2.41$	5	5	$dx2.7$
2	6	7	3	8	10	4	9	12	4.15	10	14	4.41	11	16	4.7
3	12	19	5	14	24	6	15	27	6.15	16	30	6.41	17	33	6.7
4	18	37	7	20	44	8	21	48	8.15	22	52	8.41	23	56	8.7
5	24	61	9	26	70	10	27	75	10.15	28	80	10.41	29	85	10.7
6	30	91	11	32	102	12	33	108	12.15	34	114	12.41	35	120	12.7
7	36	127	13	38	140	14	39	147	14.15	40	154	14.41	41	161	14.7
8	42	169	15	44	184	16	45	192	16.15	46	200	16.41	47	206	16.7
9	48	217	17												
CENTER COUNTS AS LAYER EVEN IF ONLY ONE WIRE.															

WIRING HARNESSSES, MOLDED CABLE ASSEMBLIES,
HYBRID CABLE ASSEMBLIES, AND
CONVOLUTE TUBING CABLE ASSEMBLIES

.387 divided by .115 = 3.4 (go to figure 5), find 3.4 in "N" column and read the number opposite or closest (13). This number represents the number of wires which will twist around the core. Next, add twice the wire diameter to the core diameter: $(2 \times .115) + .387 = .617$. Next, take .617 and divide by .058 which is 10.6; find this number in figure 5 and read "N" which is 34. This is the number of wires which will twist around the "new" core diameter of .617.

Again add twice the wire diameter to the core diameter $(2 \times .058) + .617 = .733$. Only 34 of the 37 conductors can be used in this layer, therefore, an additional layer must be added to accommodate the remaining 3 wires. $.733$ divided by .058 = 12.64. From figure 5, 41 wires are needed to fill this layer. The three remaining wires plus 38 filler strands of the same diameter are required for the outer layer. Continue on with tape, shield, and jacket requirements.

NOTE: Always use maximum diameters and/or thickness to establish maximum cable diameter which will be the worst case condition for form, fit, and function.

600.3.10 Fillers. Fillers are included when it is desirable to round out a cable to obtain symmetry or as a replacement for a missing conductor. They also act as a cushion in heavy-duty cables subjected to flexing and impact. The most commonly used fillers are cotten, jute, vinyl, polyethylene, fiberglass, and twisted polyethylene monofilaments. Table XXII gives the filler factors to calculate filler diameters used to fill voids between wires in a multiconductor cable design.

600.3.11 Molding compound selection. Molding compound selection is based on the jacket material specified and the environmental conditions the cable must withstand. As an example, a cable using extruded neoprene tubing would have a polyurethane molding compound because the two materials are compatible and are in similar temperature ranges. The manufacturer of the molding compound will recommend specific primers or provide preparation instructions for obtaining acceptable bonds at the mold entries. The cables are prepared for the molding operation (see figure 6) by taping the wire bundles and blowing on the jackets over the bundles. The jackets are string tied or sealed at the ends to prevent molding compounds extending into the jacket area thereby eliminating the flexibility created with the lay pattern. The jackets and tape are primed with primer compatible with the molding compound to ensure good adhesion.

The mold (see figure 7) is machined to the configuration requirements allowing for about 3/32 inch molding compound over the jackets. Cable entries are provided with tapered ends to reduce stress when the legs are bent or handled. Before each shot, the molds are sprayed with a mold release agent to prevent the molding compound from adhering to the mold upon removal of the cable. Some molds are Teflon coated internally to eliminate using

WIRING HARNESSES, MOLDED CABLE ASSEMBLIES,
 HYBRID CABLE ASSEMBLIES, AND
 CONVOLUTE TUBING CABLE ASSEMBLIES

NOTES:

This chart to be used only for
 for 10 wires (N) and more.

Number (N) of wires of diameter
 'd' which can be cabled over a
 layer diameter "D". Divide "D"
 by 'd' and read opposite this
 factor number of wires.

$$N. \frac{\pi}{\text{ARC Sin } \frac{1 + Z/d}{D + d + T}}$$

Z/d = 4.7%
 4.7% Z's the increase in the
 wire dia. when each layer
 increases 6 wires on account
 of the angle of the lay.

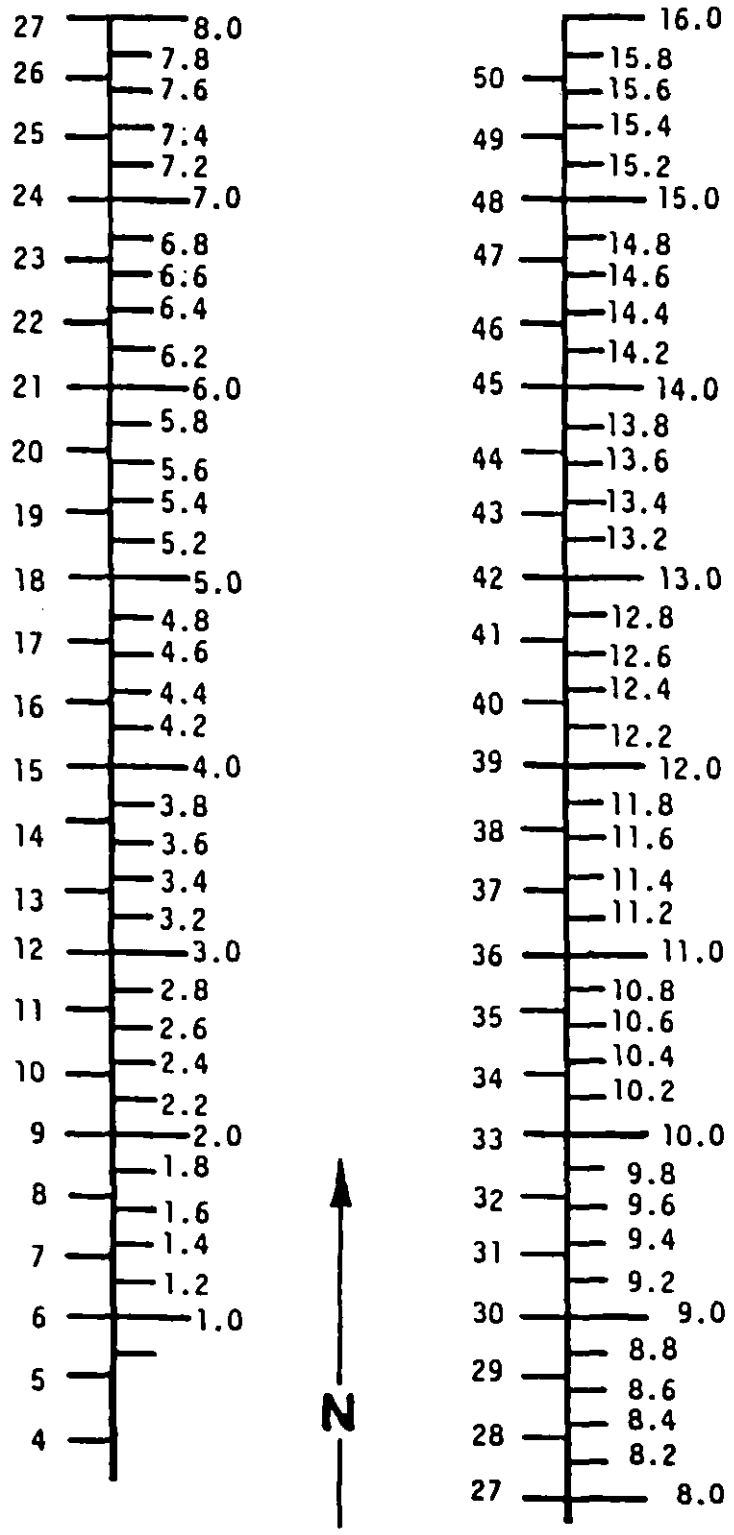
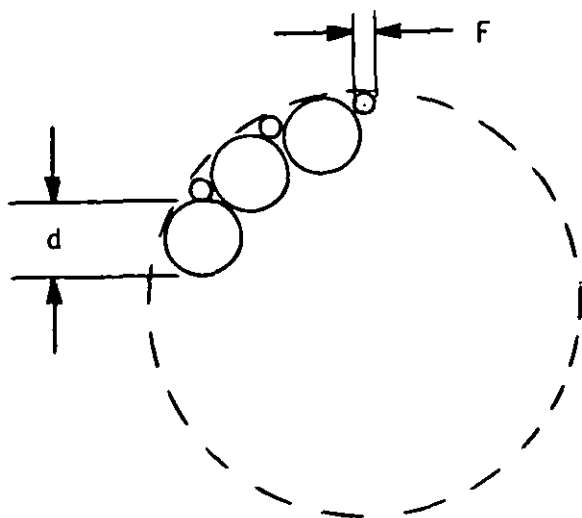

FIGURE 5. Calculation chart.

**WIRING HARNESSES, MOLDED CABLE ASSEMBLIES,
 HYBRID CABLE ASSEMBLIES, AND
 CONVOLUTE TUBING CABLE ASSEMBLIES**

TABLE XXII. Filler factors.



Number of wires in lay pattern	Filler size factor (F)
2	.67d
3	.50d
4	.41d
5	.39d
6	.37d
7	.34d
8 to 10	.32d
11 to 17	.31d
18 to 24	.28d
25 and up	.25d

SECTION 600
WIRING HARNESSES, MOLDED CABLE ASSEMBLIES,
HYBRID CABLE ASSEMBLIES, AND
CONVOLUTE TUBING CABLE ASSEMBLIES

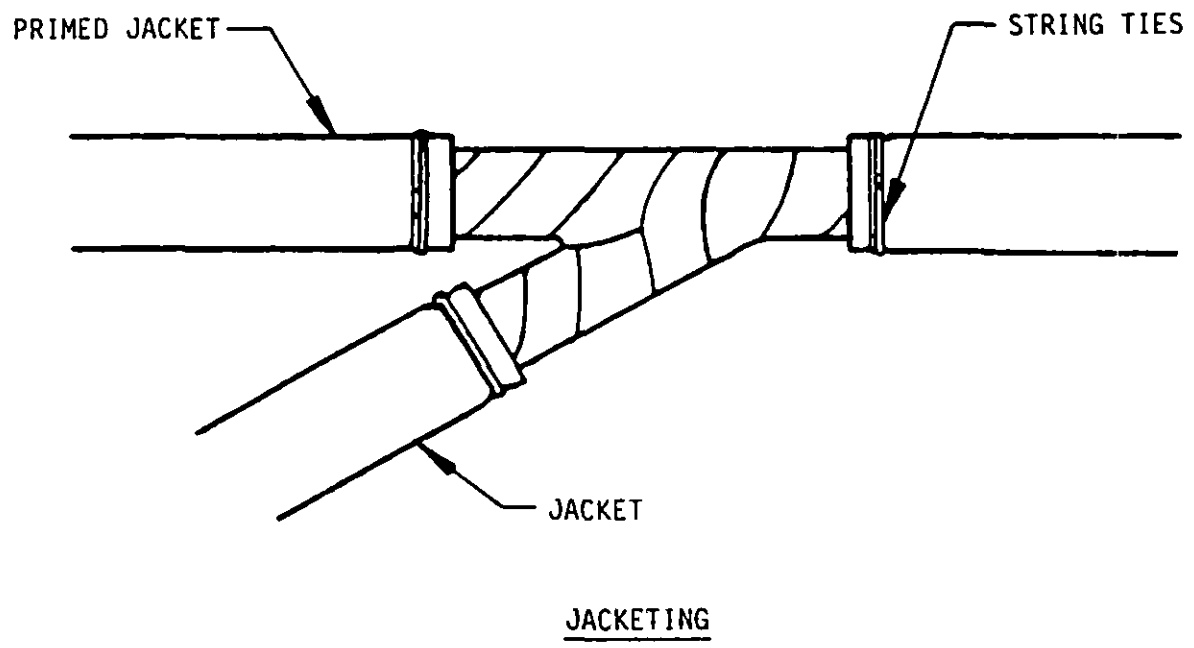
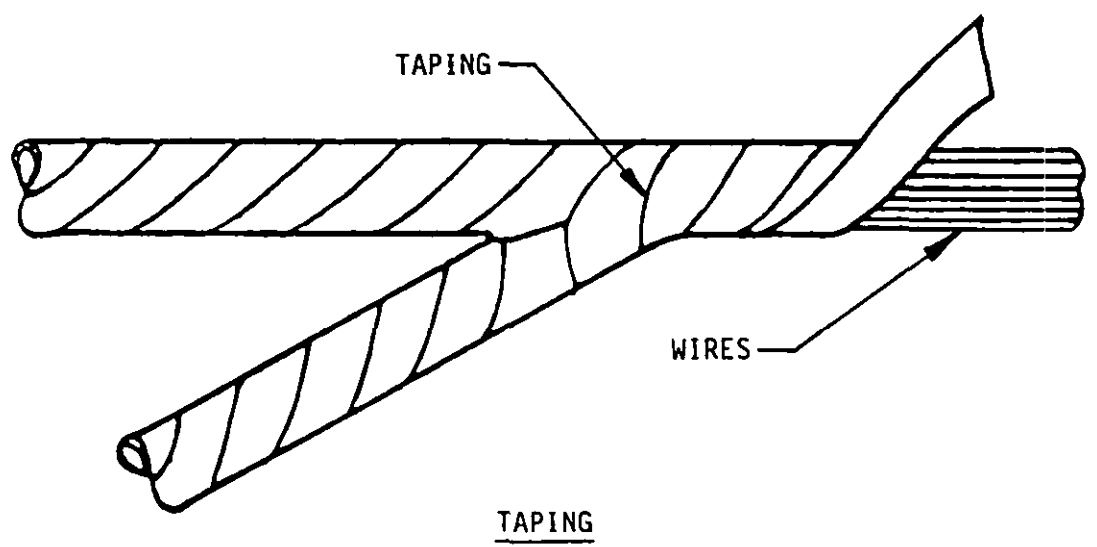
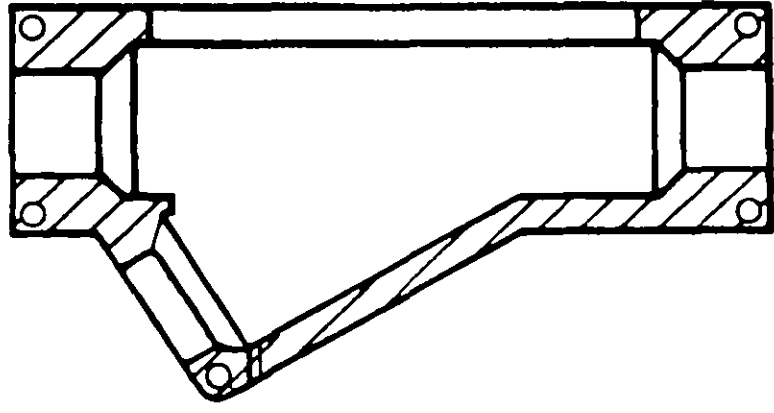
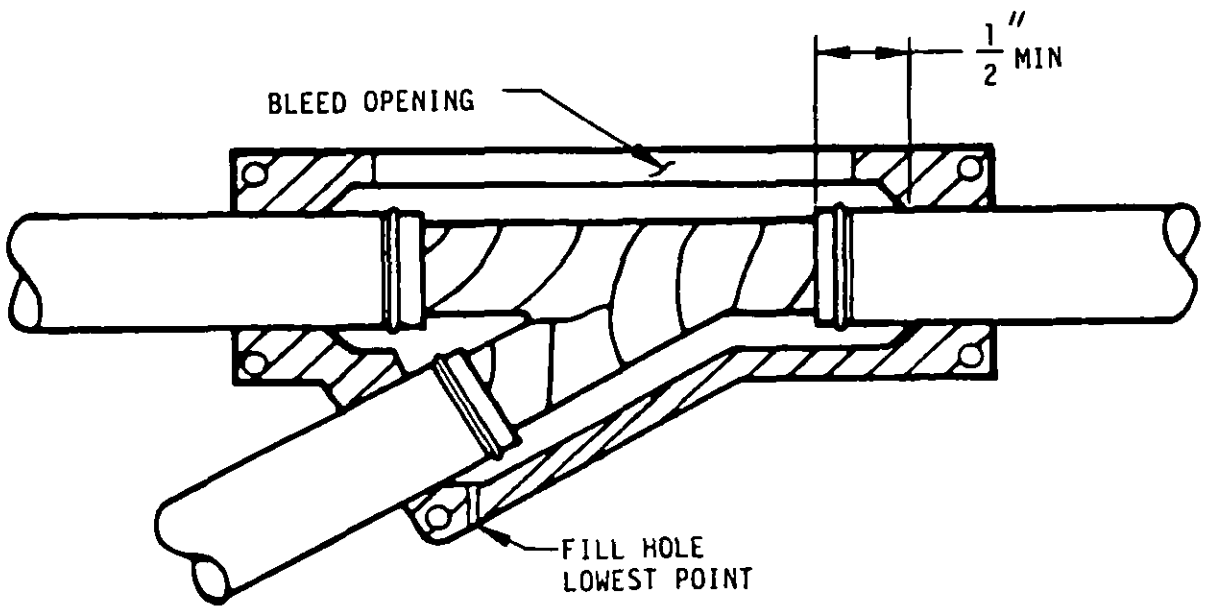

FIGURE 6. Mold preparation.

WIRING HARNESES, MOLDED CABLE ASSEMBLIES,
HYBRID CABLE ASSEMBLIES, AND
CONVOLUTE TUBING CABLE ASSEMBLIES



MOLD



LOADING MOLD

FIGURE 7. Molding.

MIL-STD-339(AT)
SECTION 600
WIRING HARNESSSES, MOLDED CABLE ASSEMBLIES,
HYBRID CABLE ASSEMBLIES, AND
CONVOLUTE TUBING CABLE ASSEMBLIES

mold release. The prepared assembly is positioned in the mold with the jackets preferably extending at least 1/2 inch into the mold area. The compound is injected into the mold through an opening in the lowest point of the mold. Compound is injected until it extrudes from the bleed openings to ensure proper fill and all air has been removed. The molding compound is now cured to manufacturer's recommended temperature and time before the cable is removed from the molds.

Connector termination is accomplished similar to those on wiring harnesses except after the wire is terminated, the wire bundle is properly dressed in the molds to ensure consistent wall thickness around the bundles.

If the cable dimensional tolerances are tightly controlled, a mold mounting board is appropriate. The molds are physically mounted on a board in the three dimensional configuration that will maintain length and connector orientation to close tolerances.

When design dictates an overall shield requirement, the termination at the connector can be accomplished using a special backshell and magnaforming or crimping a metal ring to retain the shield (see figure 8). Standard backshells may also be purchased that provide mechanical shield terminations, but increase the cost of the assembly.

600.3.12 Hybrid cable assemblies. Hybrid cable assemblies are fabricated using heat-shrinkable tubing and heat-shrinkable boots over the wires to provide a moisture seal and protect the wire insulation from abrasion.

Construction of hybrid cable assemblies usually starts with the main trunk wiring group (see figure 9) and proceeds to the first breakout. To provide a moisture seal, heat-sealable tape is wrapped over the wire bundle with a minimum of 50 percent overlap. The heat-sealable tape must be tightly wrapped to maintain a minimum cable diameter. The heat-sealable tape is then cured at temperatures and time specified by the manufacturer.

Connector boots and heat-shrinkable tubing are installed over the main wire bundle until the first breakout. Heat-shrinkable tubing is uniformly shrunk to minimum diameters determined by the bundle size and is visually inspected for cracks or splits after shrinking. The tubing length is designed to extend into a connector boot or breakout boot approximately 1 to 1-1/2 inches. Branch legs that are longer than 3 feet may require multiple sections of heat-shrinkable tubing to be joined together with one tube overlapping the other.

WIRING HARNESSES, MOLDED CABLE ASSEMBLIES,
HYBRID CABLE ASSEMBLIES, AND
CONVOLUTE TUBING CABLE ASSEMBLIES

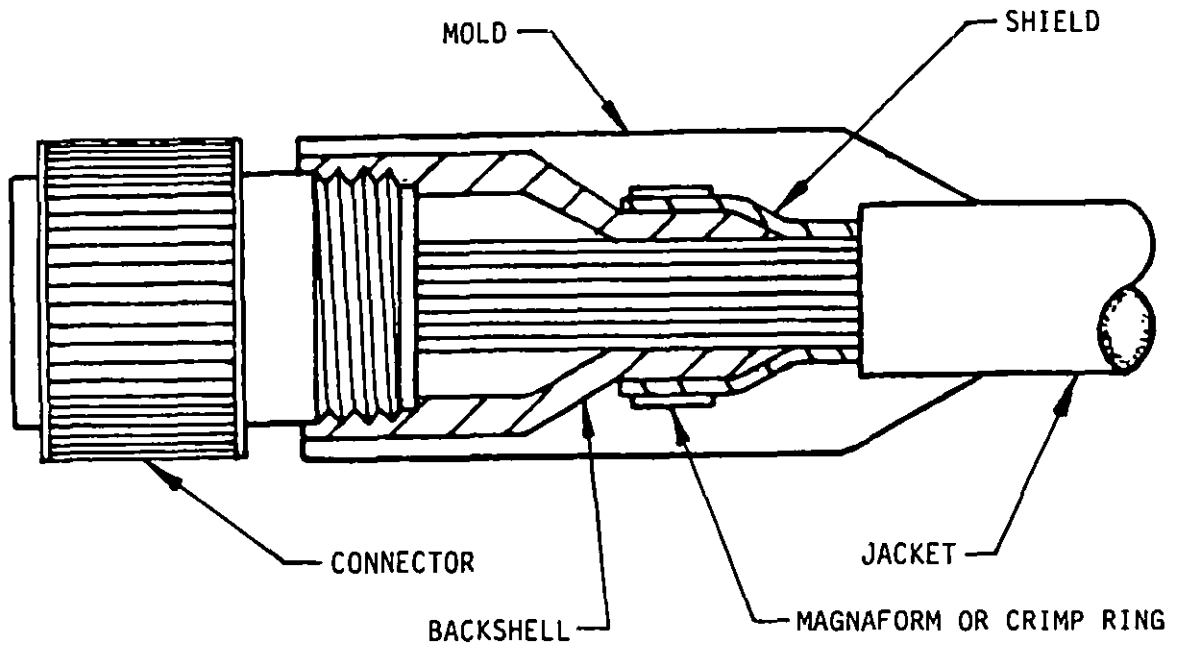

SPECIAL BACKSHELL

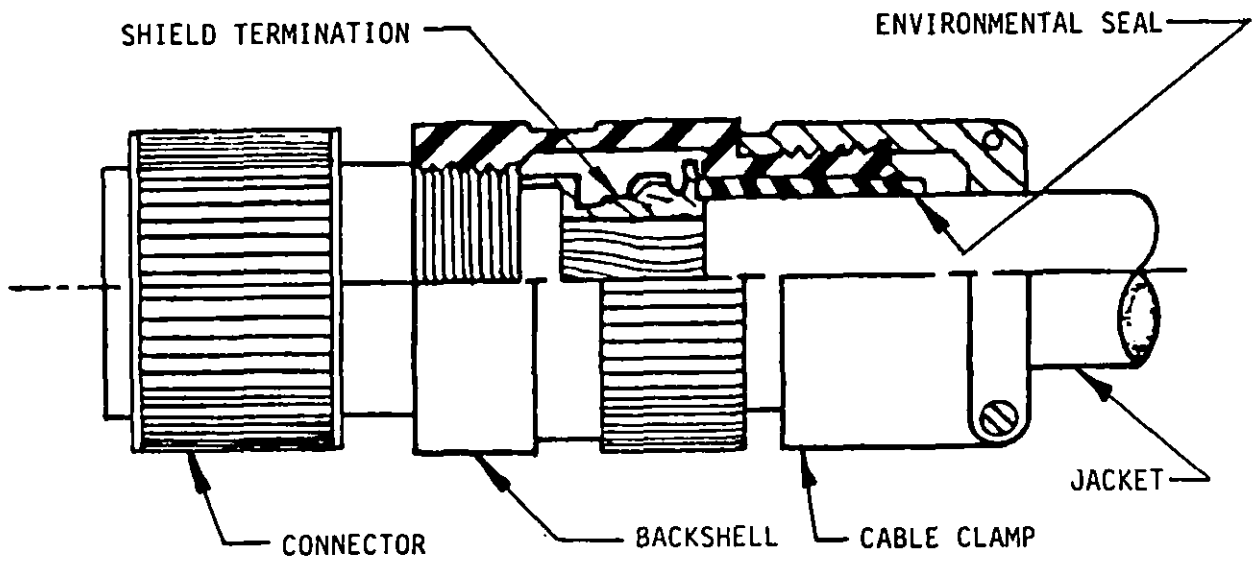

STANDARD BACKSHELL

FIGURE 8. Shield terminations.

WIRING HARNESES, MOLDED CABLE ASSEMBLIES,
HYBRID CABLE ASSEMBLIES, AND
CONVOLUTE TUBING CABLE ASSEMBLIES

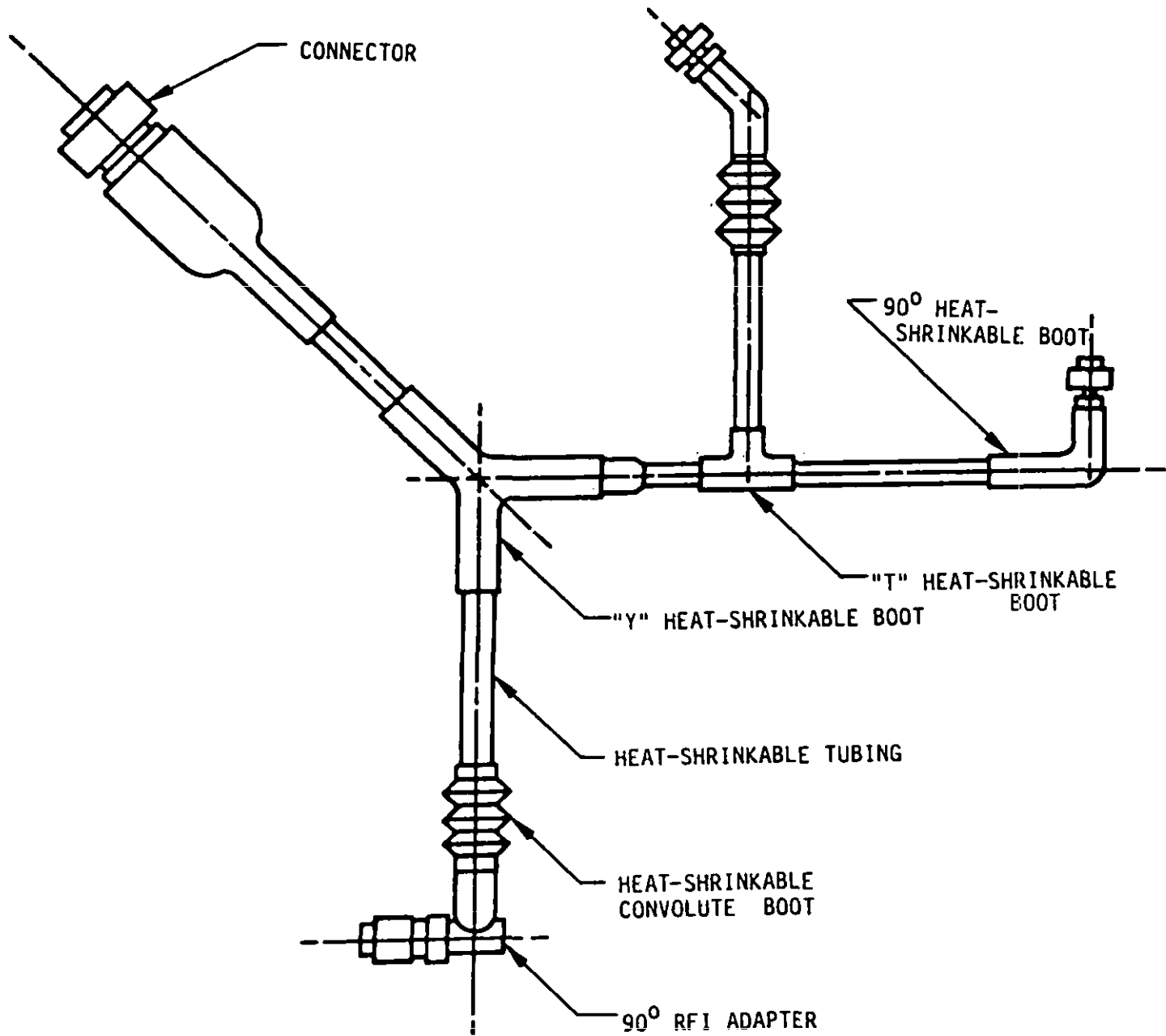

FIGURE 9. Hybrid cable assembly.

WIRING HARNESSES, MOLDED CABLE ASSEMBLIES,
HYBRID CABLE ASSEMBLIES, AND
CONVOLUTE TUBING CABLE ASSEMBLIES

The wire is then separated into branch legs of two or more with the proper size wire directed towards specific connector termination or another breakout to be split again. A "T" breakout, "Y" breakout, or multiple breakout boot (see figure 10) is installed over the separated wires. This method of construction is continuous until each branch is completed and all branch legs prepared up to a connector or terminal termination requirement. Wire termination at the connector can be accomplished by soldering or crimping, depending on the connector design selected for the cable. If the connector has removable crimp contacts, the connector manufacturer supplies the data for stripping the wire insulation and the proper crimp tools to use for each wire size. Insertion and removal tools are supplied with the connector in most cases.

Heat-shrinkable solder sleeves are used to terminate wire shields to the pigtail wires at the connector. Sleeves are placed no further than 3 inches from the rear of the connector grommet on connectors with straight backshells and 4 inches on connectors with 45- or 90-degree backshells. The sleeves are staggered to keep the wire bundle at a minimum. Unterminated shield ends are covered with heat-shrinkable tubing and extend a minimum of 1/4 inch on each side of the shield end. When all the proper terminations are completed per the wiring diagram, the connector boots are moved to position (see figure 11) and bonded with adhesive, both at the connector adapter and heat-shrinkable tubing.

Cable assemblies requiring radio frequency interference (RFI) shielding are provided with a tubular RFI shield over the wire bundle and under the wiring harness jacketing. Where a shield ends, the shield is trimmed and sealed to eliminate frayed ends. Shields are not spliced. Shielding tape wrap is used at transition points and will overlap the RFI tubular shielding by approximately 2 inches. Shielding tape wrap is held in position by lacing in two places on each end or lacing the complete breakout.

Heat-shrinkable boots are purchased in standard sizes for specific connectors and may be provided with cable entries of a couple of sizes. Breakouts are available in a limited number of configurations and require special methods to accommodate all possible cable branch leg diameters. Most problems are resolved by building up the cable diameter with heat-shrinkable tubing where the boot diameter is much larger than the cable diameter. Heat-shrinkable boots and tubing are available in neoprene and viton materials and are selected based on the temperature and environmental requirements.

600.3.13 Convolute tubing cable assemblies. These cables are modular constructed with convolute tubing, metal breakouts, and metal connector backshells that protect the wire insulation.

Convolute tubing cable assemblies are similar in construction to hybrid cable assemblies. The wires specified on the wiring diagram are cut to the length requirement from one connector termination to the other. Excess wire of approximately 6 inches in length is allowed for adjustment and final termination. The wires specified for the main trunk are bunched together and laid out until the first breakout. Convolute tubing for this section is

MIL-STD-339(AT)

SECTION 600

WIRING HARNESSES, MOLDED CABLE ASSEMBLIES,
HYBRID CABLE ASSEMBLIES, AND
CONVOLUTE TUBING CABLE ASSEMBLIES

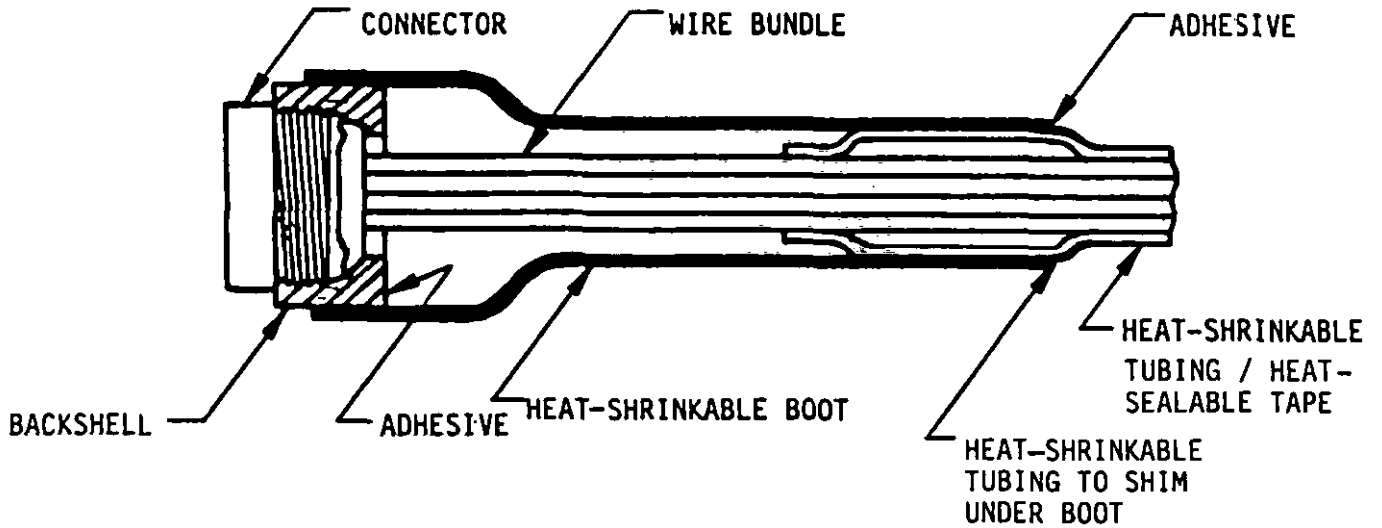

CONNECTOR

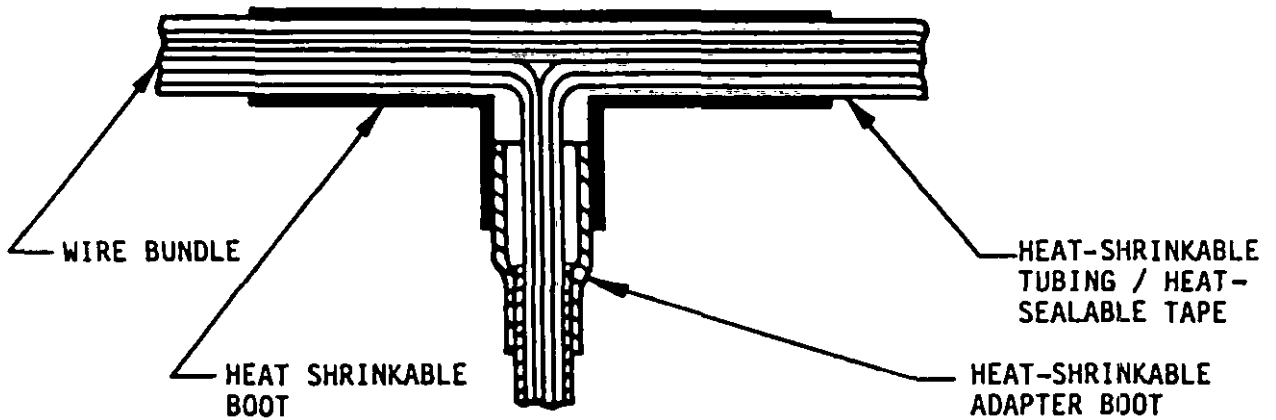

"T" BREAKOUT

FIGURE 10. Connector and breakout termination.

MIL-STD-339(AT)
SECTION 600
WIRING HARNESSES, MOLDED CABLE ASSEMBLIES,
HYBRID CABLE ASSEMBLIES, AND
CONVOLUTE TUBING CABLE ASSEMBLIES

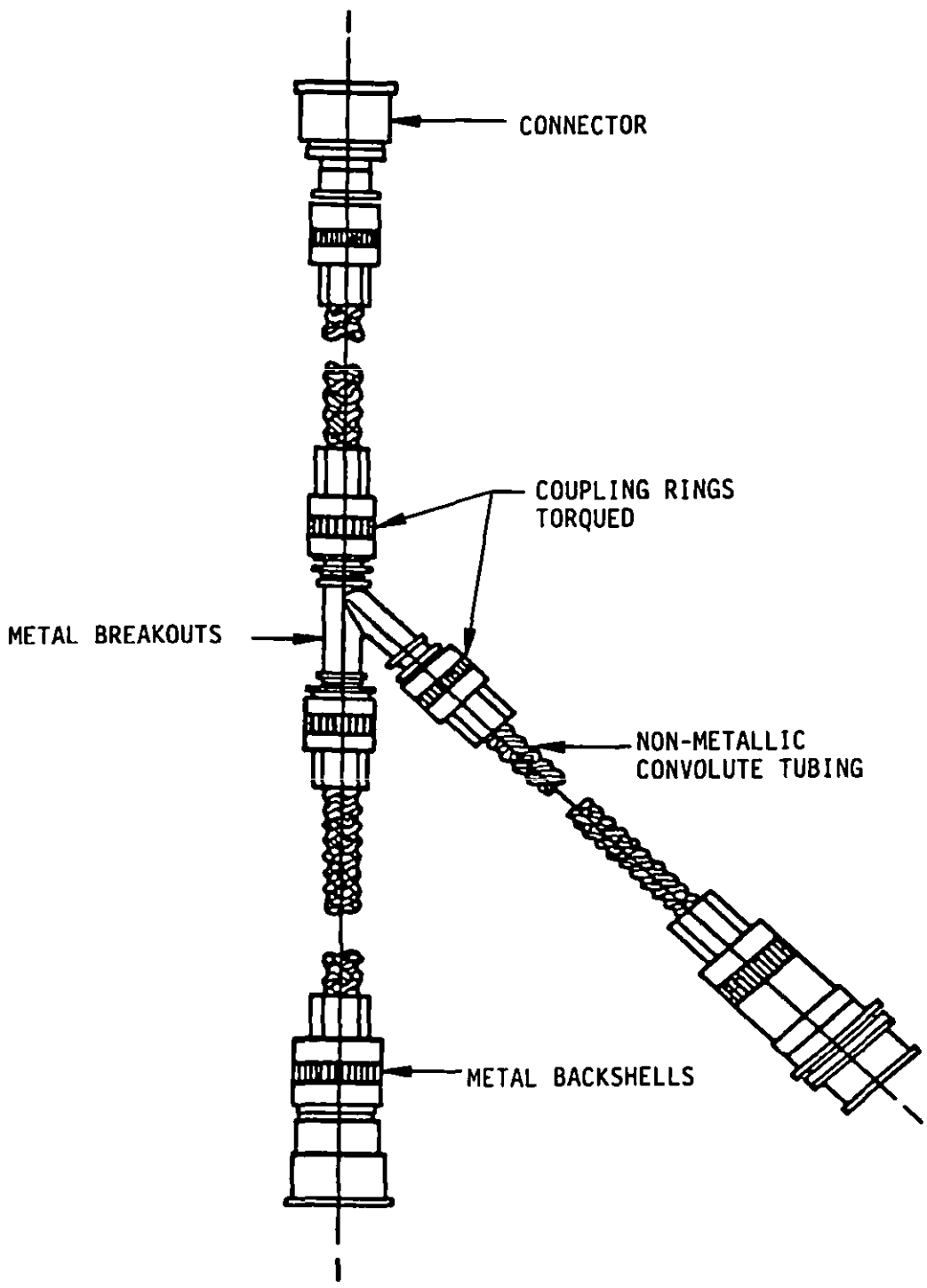

FIGURE 11. Convolute tubing cable assembly.

MIL-STD-339(AT)
SECTION 600
WIRING HARNESSES, MOLDED CABLE ASSEMBLIES,
HYBRID CABLE ASSEMBLIES, AND
CONVOLUTE TUBING CABLE ASSEMBLIES

installed over the wires and then the wires are separated to form the breakout. Each branch of the cable must be threaded through the breakout openings before the breakout can be threaded onto the convolute tubing and positioned accurately for further fabrication. Branch convolute tubing is installed on each leg of the breakout to build up the modular constructions. This pattern of assembly continues until all the breakouts are completed and each branch of convolute tubing is installed up to final termination at a connector. When all the breakouts are positioned and oriented in their final configuration, the coupling rings are torqued to the manufacturer's recommended values.

Approximately 4 to 6 inches of excess wire will be protruding beyond the convolute tubing for wire termination to the connector. The individual wires are prepared by stripping the wire insulation to recommended lengths for proper crimping of contacts to the wire. Crimp tools are specified by the connector manufacturer or the connector procurement specification. The connectors are terminated away from the convolute tubing and when the backshell coupling rings are threaded to the connector. There is excess wire slack for retermination if necessary. The wire slack also provides a strain relief when the cables are bent during handling or installation.

The advantage of convolute systems is that high-temperature and environmental-resistant materials can be specified. Another advantage of the modular construction is that virtually all mechanical joints are not dependent on adhesive systems for sealing. The modular system provides the means for reparability and even replacement of circuitry if necessary. If there is damage to a wire, the coupling ring can be uncoupled allowing access to the back of the connector. The repair can then be made. If the wire or circuit must be replaced, the other end of the assembly can be uncoupled. A replacement wire is attached to the damaged wire and pulled through the assembly. Termination can now be accomplished using the specified torque values.

The disadvantage of convolute systems is their initial cost is greater than the cost of other type cable designs. One off-setting factor is the cable life requirement can reduce the total program cost. If the application is for many years of service, the convolute system will become advantageous due to minimum replacement costs. The convolute design may have an envelope disadvantage because of the convolute tubing sizes or metal breakouts. Convolute diameters generally are larger than regular jacket diameters because the wires must be threaded through the tubing and in some cases would preferably cover 80 percent of the inside diameter area. All these different problems have to be worked out at the same time of the design to best take advantage of convolute tubing cable assembly design.

600.3.14 Shield terminations. There are four basic types of shield terminations and each basic type will be discussed.

WIRING HARNESSSES, MOLDED CABLE ASSEMBLIES,
 HYBRID CABLE ASSEMBLIES, AND
 CONVOLUTE TUBING CABLE ASSEMBLIES

600.3.14.1 Inner/outer shield terminations. Inner and outer shield terminations are accomplished with MS21981 and MS21980 ferrules, respectively. This construction consists of an inner hard-brass alloy sleeve which is installed over the wire and under the shield. An outer sleeve of copper or brass alloy is installed over the shield and crimped into position. This captivates the two sleeves with the shield in between, with or without a shield jumper (see figure 12).

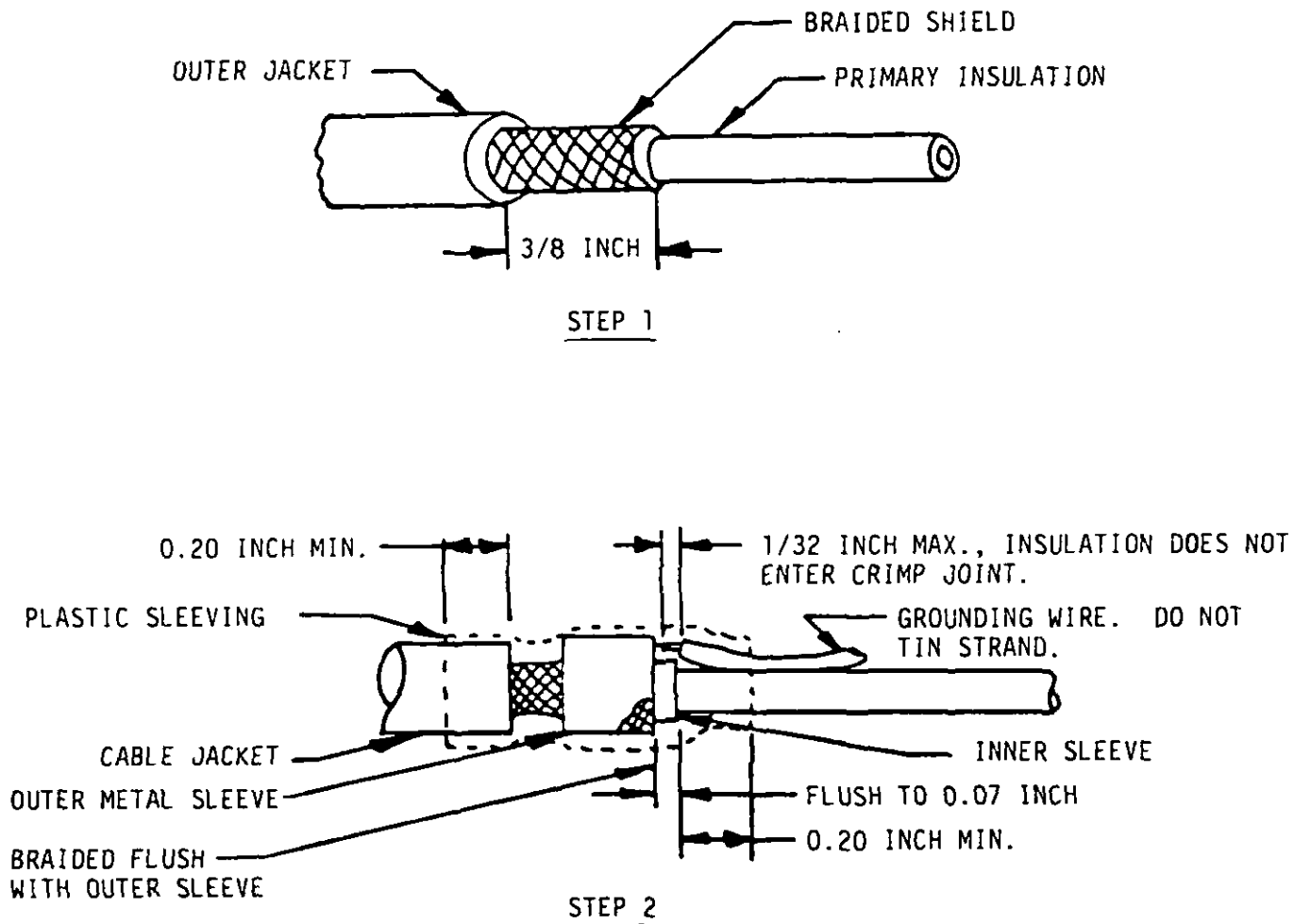

FIGURE 12. Inner/outer shield termination.

WIRING HARNESSSES, MOLDED CABLE ASSEMBLIES,
HYBRID CABLE ASSEMBLIES, AND
CONVOLUTE TUBING CABLE ASSEMBLIES

The following is a guide to choosing the best inner and outer sleeves:

- a. Single Conductor, Inner Sleeve. Select sleeve with inside diameter (I.D.) at least 0.005 to 0.010 inch larger than the measured diameter over the primary insulation of the wire being grounded.
- b. Multiple Conductor, Inner Sleeve. Add a short piece of conductor or a dummy of the equivalent size of one conductor and select a sleeve that will slide freely over the grouping without forcing or binding. Remove the extra wire before assembling.
- c. Outer Sleeve. Select the outer sleeve with I.D. equal to the total of the following: (1) The outside diameter (O.D.) of the inner sleeve; (2) 0.025 inch for the shielded braid; (3) the diameter of the grounding conductor or twice its diameter, if more than one grounding wire is being installed.

NOTE: The diameter of #24 AWG is 0.025 inch and the diameter of #22 AWG is 0.032 inch. If the outer sleeve I.D. is not listed, the next larger size shall be used.

600.3.14.2 Floating shields. The term floating shields means terminating the shielded portion of the wire complex but not establishing a shield ground (also called "dead ending").

The shield braid and outer jacket shall be trimmed square as shown in figure 13. The heat-shrinkable sleeve shall be installed over the trim point with a minimum of .020 inch material on each side.

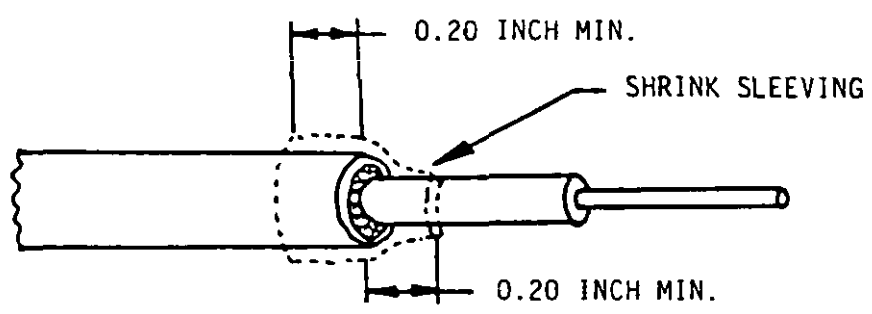
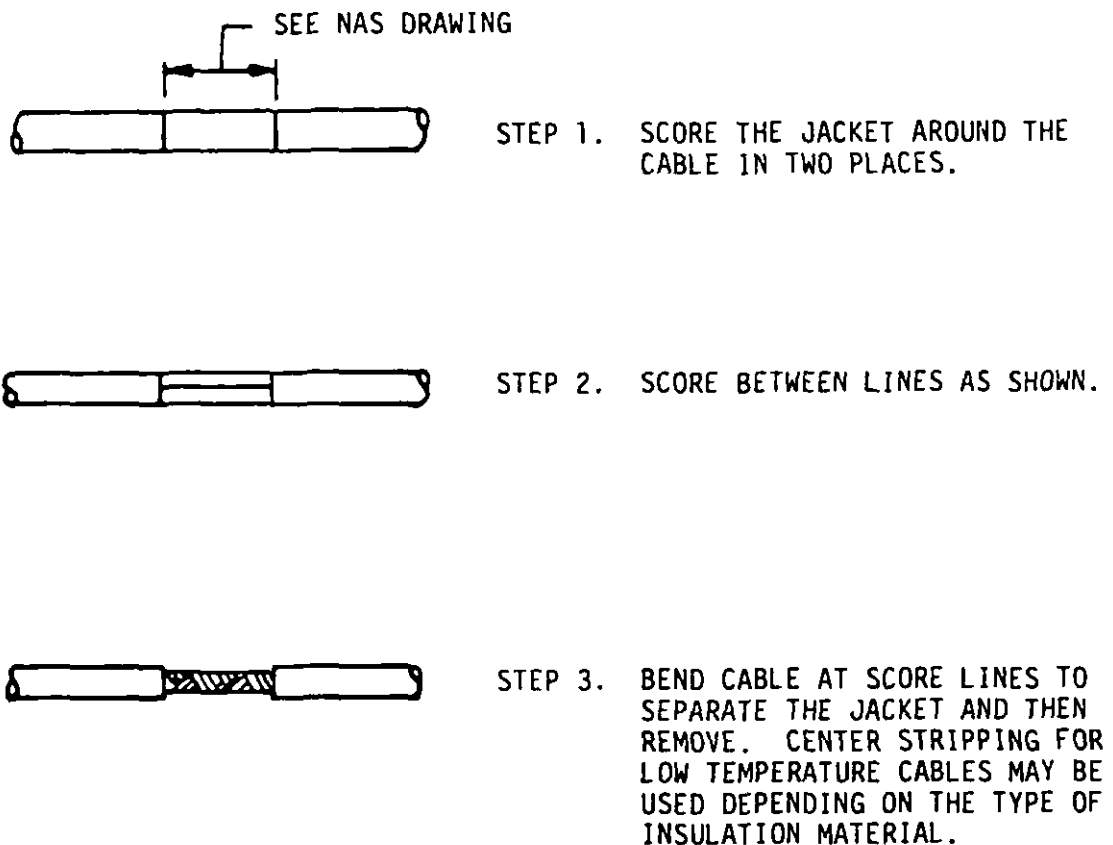

FIGURE 13. Floating shield.

WIRING HARNESSSES, MOLDED CABLE ASSEMBLIES,
HYBRID CABLE ASSEMBLIES, AND
CONVOLUTE TUBING CABLE ASSEMBLIES

600.3.14.3 Solder sleeve terminations. Solder sleeve terminations shall be in accordance with NAS 1744, NAS 1745, NAS 1746, and NAS 1747. Preparation of wire and position of solder sleeves is explained in the following paragraphs but detailed terminations should be as specified in the applicable NAS document.

- a. Center (window) stripping. Center stripping allows the shielding to continue to the connector for maximum RFI protection (see figure 14 for the procedure).



NOTE: STAGGERING THE STRIP LOCATION ON THE CABLES IN A BUNDLE WILL PRODUCE A SMALLER BUNDLE DIAMETER.

FIGURE 14. Procedure for center stripping.

WIRING HARNESSES, MOLDED CABLE ASSEMBLIES,
HYBRID CABLE ASSEMBLIES, AND
CONVOLUTE TUBING CABLE ASSEMBLIES

- b. End stripping. End stripping terminates the end of the shield and allows for exposure of a length of primary insulation (see figure 15 for the procedure).

SEE NAS DRAWING



STEP 1. SCORE AND REMOVE THE JACKET.

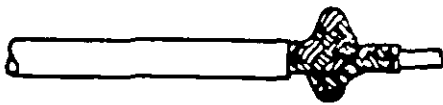

STEP 2. BUNCH THE SHIELD.



STEP 3. TRIM SHIELD BACK TO JACKET AS SHOWN.

SEE NAS DRAWING



STEP 4. SCORE AND REMOVE THE JACKET.

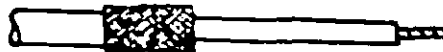

STEP 5. FOR LOW-TEMPERATURE INSULATION, FOLD THE SHIELD BACK OVER THE JACKET AS SHOWN. MAKE SURE CABLE BRAID IS SMOOTH AND FLAT.

FIGURE 15. Procedure for end stripping.

- c. Ground lead. Strip insulation as shown in figure 16.

WIRING HARNESSES, MOLDED CABLE ASSEMBLIES,
HYBRID CABLE ASSEMBLIES, AND
CONVOLUTE TUBING CABLE ASSEMBLIES

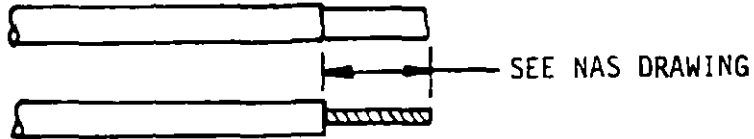

FIGURE 16. Ground lead.

- d. Assembly. Position stripped portion of ground lead over stripped portion of the shield. Place the wires in the solder sleeve. Center the stripped portion between the meltable inserts. The stripped portion of both conductor and cable should be centered in the solder sleeve (see figure 17).



FIGURE 17. Assembly.

- e. Heat application. Place the assembled unit in an infrared or hot-air reflector. During heating the following occurs:
- (1) Tubing shrinks at ends,
 - (2) Inserts melt and flow,
 - (3) Solder preform collapses,
 - (4) Tubing at center completes shrinking.

Heat until solder melts and flows along the shield and ground lead, forming a fillet of solder on both sides.

NOTE: It is important not to confuse the collapse of the preform with the actual flow of the solder.

Immersion-resistant sleeves require the solder preform to be heated first until it has melted and flowed. Then move to each end and heat the meltable insert until the material flows freely between the tubing and cable.

600.3.14.4 Pigtailing braid grounding. After stripping the jacket, push braid back and "pigtailing" by bringing insulated conductor through the braid next to the jacket. Braid design requires a high degree of "push-back" for proper pigtailing (see figure 18).

SECTION 600
WIRING HARNESSSES, MOLDED CABLE ASSEMBLIES,
HYBRID CABLE ASSEMBLIES, AND
CONVOLUTE TUBING CABLE ASSEMBLIES

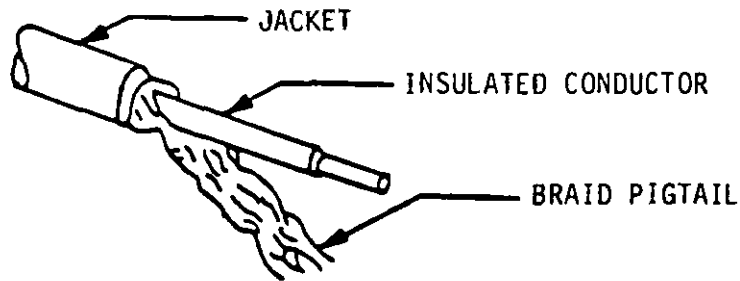

FIGURE 18. Pigtailed braid.

Assemble as shown in figure 19 (the pigtail may dress either way).

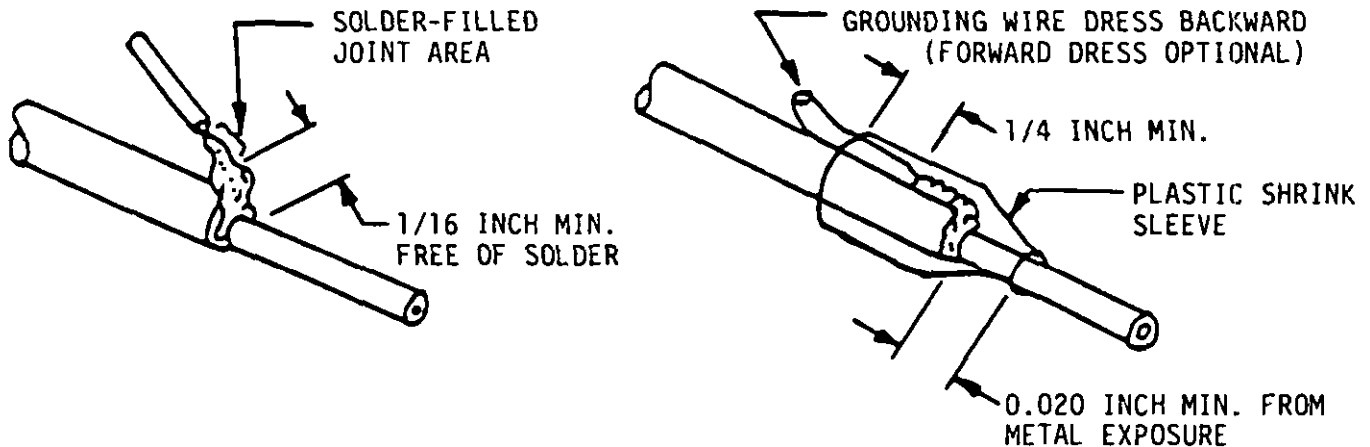

FIGURE 19. Pigtailed braid assembly.

600.3.15 Useful formulas for cables.

600.3.15.1 Conductor weight.

$$W = \frac{\pi(D/2)^2}{C} \text{LPGNK} = \text{lb}/1000 \text{ ft.}$$

W = weight/1000 ft.

D = Diameter of solid strand, in.

L = Length of conductor, in.

P = lb. water/gal

G = Density of copper

N = Number of strands

C = in³ of water/gal

K = Weight increase due to strand

No. of strands

19

37

49

133 or more

K

1.02

1.026

1.03

1.04

WIRING HARNESSSES, MOLDED CABLE ASSEMBLIES,
HYBRID CABLE ASSEMBLIES, AND
CONVOLUTE TUBING CABLE ASSEMBLIES

600.3.15.2 Insulation weight.

$$W = \frac{D^2 - d^2}{2} \text{ KG} = \text{lb}/1000 \text{ ft.}$$

- D = Diameter over insulation
- d = Diameter over conductor
- K = Constant = 680
- G = Specific gravity of insulation

600.3.15.3 Shield weight.

$$W = \frac{NCw}{\text{Cos } a} \times 1.03 = \text{lbs}/1000 \text{ ft.}$$

- N = Number ends per carrier
- C = Number of carriers
- w = Weight of one strand, lbs/1000 ft.
- a = Braid angle

600.3.15.4 Jacket weight. Same as insulation weight (except substitute "jacket" for "insulation").

600.3.15.5 Tape weight.

$$\text{Weight} = Ktf (d = tf)G = \text{lbs.}/1000 \text{ ft.}$$

- K = 1,364
- t = Tape thickness
- f = Multiplying factor
- d = Diameter of cable under tape, in.
- G = Specific gravity of tape

<u>% lap</u>	<u>f</u>
17.5	1.25
25	1.28
33	1.32
50	2.00

600.3.15.6 Twisting (cabling) loss. Use 4% for all cables.

600.4 QUALITY ASSURANCE PROVISIONS

600.4.1 Inspections. Inspections shall be performed in accordance with the applicable military specification or drawing.

600.5 PACKAGING

600.5.1 Preservation, packaging, packing, and marking. Preservation, packaging, packing, and marking for the desired level shall be in accordance with the applicable drawing or packaging requirements specified by the contracting authority.

WIRING HARNESSSES, MOLDED CABLE ASSEMBLIES,
HYBRID CABLE ASSEMBLIES, AND
CONVOLUTE TUBING CABLE ASSEMBLIES

600.6 NOTES

600.6.1 Definitions.

600.6.1.1 Accordion. A retractable cable with a series of equally spaced transverse folds.

600.6.1.2 ACR. Designation for cable with corona-resisting insulation.

600.6.1.3 Adjacent conductor. Any conductor next to another conductor in the same multiconductor cable layer or in adjacent layers.

600.6.1.4 American Wire Gage (AWG). The strand system used in designating wire diameter.

600.6.1.5 Angle of advance. The angle between a line perpendicular to the axis of the cable and the axis of any one member or strand of the braid.

600.6.1.6 Binder. Spirally served tape or thread used for holding assembled cable components in place until additional manufacturing operations are performed.

600.6.1.7 Bondable wire. An insulated wire (usually Teflon) whose surface has been treated to facilitate adherence to other materials such as potting compounds.

600.6.1.8 Braid. Woven metallic wire used as shielding for wire or cables. Also, a woven fibrous protective covering over a conductor or cable.

600.6.1.9 Braid angle. The angle between the axis of the cable and the axis of any one member or strand of the braid (also known as angle of advance). It is further the smaller of the two angles formed by the carrier and the longitudinal axis of the braid.

600.6.1.10 Braid carrier. The spool or bobbin on a braiding machine which holds one group of strands or filaments consisting of a specific number of ends.

600.6.1.11 Braid ends. The number of individual strands used to make up one carrier. The strands are wound side by side on the carrier bobbin and lay parallel in the finished braid.

600.6.1.12 Bunched strands. Term applied to a group of strands twisted together in a random manner in the same direction in one operation without regard to geometric arrangement of specific strands.

600.6.1.13 Cable. Either a stranded conductor with or without insulation and other coverings (single conductor, shielded jacketed), or a combination of conductors insulated from one another (multiple-conductor cable).

WIRING HARNESSSES, MOLDED CABLE ASSEMBLIES,
HYBRID CABLE ASSEMBLIES, AND
CONVOLUTE TUBING CABLE ASSEMBLIES

600.6.1.14 Cable core. The portion of an insulated cable lying under the protective covering. Also the first layer or conductor of a multiple-conductor cable.

600.6.1.15 Cable core binder. A wrapping of tapes or cords around the conductor of a multiple-conductor cable used to hold them together.

600.6.1.16 Cable filler. The material used in multiple-conductor cables to occupy the interstices formed by the assembly of the insulated conductors.

600.6.1.17 Cabling. Twisting together two or more insulated conductors by machine to form a cable.

600.6.1.18 Cable factor. Used in the formula for calculating the overall diameter of a cable: $D = fd$, where D = cable diameter, f = factor, and d = diameter of one conductor.

600.6.1.19 Carrier. The basic woven element of a braid consisting of one or more strands (ends) which create the interlaced effect.

600.6.1.20 Circular MIL. A unit of area equal to the area of a circle whose diameter is 1 mil (0.001 inch); equal to square mil X 0.78540. Used chiefly in specifying cross-sectional areas of round conductors.

600.6.1.21 Coating. Plating surface of a conductor to prevent corrosion and facilitate soldering. One coating commonly used on copper is tin. Term can also be applied to an insulating compound.

600.6.1.22 Cold bend. Test procedure whereby a sample wire or cable is wound around a mandrel of a specific size within a cold chamber, at a specified temperature for a specified number of turns at a given rate of speed.

600.6.1.23 Cold flow. Permanent deformation of a material due to mechanical force or pressure (not due to heat softening).

600.6.1.24 Color code. A color system for wire or circuit identification by use of solid colors, tracers, braids, and surface printing.

600.6.1.25 Concentric. A center core surrounded by one or more layers of helically wound strands in a fixed, round, geometric arrangement. It is optional for the direction of lay for successive layers to be alternately reversed or in the same direction. If the direction is the same, the lay length shall increase with each successive layer. The standard direction of the outer layer is left hand.

600.6.1.26 Concentric lay cable. Either a concentric lay conductor as defined next, or a multiple-conductor cable composed of a central core surrounded by one or more layers of helically laid insulated conductors.

WIRING HARNESSSES, MOLDED CABLE ASSEMBLIES,
HYBRID CABLE ASSEMBLIES, AND
CONVOLUTE TUBING CABLE ASSEMBLIES

600.6.1.27 Concentric lay conductor. A conductor composed of a central core surrounded by one or more layers of helically laid wires. (Note: In the most common type of concentric lay conductor, all wires are of the same size and the central core is a single wire.)

600.6.1.28 Concentric strand. A strand that consists of a center wire or core surrounded by one or more layers of spirally wound wires. Each layer after the first has six more strands than the preceding layer and is applied in a direction opposite to that of the layer under it.

600.6.1.29 Concentricity. In a wire or cable, the measurement of the location of the center of the conductor with respect to the geometric center of the circular insulation.

600.6.1.30 Conductance. The reciprocal of resistance, it is the ratio of current passing through a material to the potential difference at its ends.

600.6.1.31 Conductivity. Reciprocal of volume resistivity. Conductance of a unit cube of any material.

600.6.1.32 Conductor. A wire or combination of wires not insulated from one another, suitable for carrying current.

600.6.1.33 Contra-helical. The direction of a layer with respect to the previous layer, i.e., a layer spiraling in an opposite direction than the preceding layer within a wire or cable.

600.6.1.34 Copolymer. A compound resulting from the chemical reaction of two chemical different monomers with each other.

600.6.1.35 Core. In cables, a term referring to a component or assembly over which other materials are applied, such as additional components, shield, sheath, or armor.

600.6.1.36 Corona. A luminous discharge due to ionization of the gas surrounding a conductor around which exists a voltage gradient exceeding a certain critical value.

600.6.1.37 Corona resistance. The time that insulation will withstand a specified level of field-intensified ionization without resulting in the immediate complete breakdown of the insulation.

600.6.1.38 Coverage. The calculated percentage which defines the completeness with which a metal braid covers the underlying surface. The higher the percentage of coverage, the greater the protection against external interference.

600.6.1.39 Coverings. Textile braids of jackets or rubber, plastics, or other material applied over a wire or cable to provide mechanical protection.

WIRING HARNESSSES, MOLDED CABLE ASSEMBLIES,
HYBRID CABLE ASSEMBLIES, AND
CONVOLUTE TUBING CABLE ASSEMBLIES

600.6.1.40 Creep. The dimensional change with time of a material under load.

600.6.1.41 Creepage. Electrical leakage on a solid dielectric surface.

600.6.1.42 Creepage surface. An insulating surface which provides physical separation as a form of insulation between two electrical conductors of different potential.

600.6.1.43 Cross-linking. The setting-up of chemical links between the molecular chains.

600.6.1.44 Cross-sectional area. For a conductor, the sum of the cross-sectional area of its component wires, each wire being measured perpendicular to its individual axis.

600.6.1.45 Crosstalk. Signal interference between nearby conductors caused by magnetic field effects.

600.6.1.46 Current. The rate of transfer of electricity. Practical unit is the ampere which represents the transfer of one coulomb per second.

600.6.1.47 Current-carrying capacity. The maximum current a conductor can carry without heating beyond a safe limit.

600.6.1.48 Cut-through. Resistance of a solid material to penetration by an object under conditions of pressure, temperature, etc.

600.6.1.49 Denier. A term used to describe the weight of a yarn (not cotton or spun rayon) which in turn determines its physical size.

600.6.1.50 Derating factor. A factor used to reduce the current-carrying capacity of a wire when used in other environments than that for which the value was established.

600.6.1.51 Dielectric.

- a. Any insulating medium which intervenes between two conductors and permits electrostatic attraction and repulsion to take place across it.
- b. A material having the property that energy required to establish an electrical field is recoverable in whole or in part, as electric energy.

600.6.1.52 Dielectric absorption. That property of an imperfect dielectric whereby there is an accumulation of electric charges within the body of the material when it is placed in an electrical field.

600.6.1.53 Dielectric constant. That property of a dielectric which determines the electrostatic energy stored per unit volume for unit potential gradient.

SECTION 600
WIRING HARNESSSES, MOLDED CABLE ASSEMBLIES,
HYBRID CABLE ASSEMBLIES, AND
CONVOLUTE TUBING CABLE ASSEMBLIES

600.6.1.54 Dielectric loss. The time rate at which electric energy is transformed into heat in a dielectric when it is subjected to a charging field.

600.6.1.55 Dielectric strength. The voltage which an insulating material can withstand before breakdown occurs, usually expressed as a voltage gradient (such as volts per mil).

600.6.1.56 Dielectric test. Tests which consist of the application of a voltage higher than the rated voltage for a specified time for the purpose of determining the adequacy against breakdown of insulating materials.

600.6.1.57 Direction of lay. The lateral direction in which the elements of a cable run over the top of the cable as they recede from an observer looking along the axis of the cable.

600.6.1.58 Dissipation factor. The ratio of the power loss to the circulating voltage.

600.6.1.59 Double shield. Two shields one over the other. Maximum coverage 98%.

600.6.1.60 Eccentricity. A measure of the center of a conductor's location with respect to the circular cross section of the insulation. Expressed as a percentage of center displacement of one circle within the other.

600.6.1.61 Electromotive Force (EMF). Voltage. The force which causes current to flow in a circuit.

600.6.1.62 Electro-tinned. Electrolytic process of tinning wire using pure tin.

600.6.1.63 Elongation. The fractional increase in length of a material stressed in tension.

600.6.1.64 EMF. Abbreviation for Electromotive Force.

600.6.1.65 End-to-end check. Tests conducted on a completed wire and/or cable run to assure continuity.

600.6.1.66 Ends. The number of wires or threads on a braid carrier.

600.6.1.67 Fatigue resistance. Resistance to metal crystallization which leads to conductors or wires breaking from flexing.

600.6.1.68 FEP. Abbreviation for Fluorinated Ethylene Propylene, often used as wire insulating material.

600.6.1.69 FEPB. Designation for FEP insulated wire with glass or asbestos braid.

WIRING HARNESSSES, MOLDED CABLE ASSEMBLIES,
HYBRID CABLE ASSEMBLIES, AND
CONVOLUTE TUBING CABLE ASSEMBLIES

600.6.1.70 Filler. Materials used in multiconductor cables to occupy the interstices formed by the assembled conductors. Also a plastic to improve properties and/or decrease cost.

600.6.1.71 Flame resistance. Ability of the material to extinguish flame once the source of heat is removed.

600.6.1.72 Flammability. Measure of the material's ability to support combustion.

600.6.1.73 Flashover. A disruptive discharge around or over the surface of a solid insulator.

600.6.1.74 Flat braid. A woven braid composed of copper strands which is rolled flat at time of manufacture to a specific width and thickness. It is generally used as a high-current conductor at low voltage.

600.6.1.75 Flex life. The time of heat aging that an insulating material can withstand before failure when bent around a mandrel of a specific radius.

600.6.1.76 Fluorinated Ethylene Propylene. FEP is similar to Polytetrafluordethylene (PTFE) but has a melting point about 50°C lower and slightly different physical properties. It is more easily processed than PTFE. Heat resistance and chemical inertness are outstanding.

600.6.1.77 Flux. The rate of flow of energy across or through a surface. Also a substance used to promote or facilitate fusion such as a material used to remove oxides from surfaces to be joined by soldering or welding.

600.6.1.78 Follower. A sleeve used to compress the grommet, thus tightening the seal around wires entering the connector.

600.6.1.79 Gage. A term used to denote the physical size of a wire.

600.6.1.80 GRD. Abbreviation for ground.

600.6.1.81 Ground. A electrical term meaning to connect to the earth (or other large conducting body to serve as an earth) thus making a complete electrical circuit.

600.6.1.82 Ground wire. A conductor leading from equipment to an electrical connection with the ground.

600.6.1.83 Harness, wiring. A group of conductors laid parallel or twisted by hand, usually with many breakouts, laced or bundled together, or pulled into a rubber sheath, used to interconnect electrical circuits.

600.6.1.84 Heat distortion. Distortion or flow of a material or configuration due to the application of heat.

MIL-STD-339(AT)
SECTION 600

WIRING HARNESSSES, MOLDED CABLE ASSEMBLIES,
HYBRID CABLE ASSEMBLIES, AND
CONVOLUTE TUBING CABLE ASSEMBLIES

600.6.1.85 Heat seal. In cabling, a method of sealing a tape wrap jacket by means of thermal fusion.

600.6.1.86 Heat shock. Test to determine stability of a material by sudden exposure to a high temperature for a short period of time.

600.6.1.87 Helical. Spiral.

600.6.1.88 Helix. Spiral winding.

600.6.1.89 Henry. Unit of inductance when the induced electromotive force of one volt is produced by the inducing current changing at the rate of one ampere per second.

600.6.1.90 Hertz (Hz). A term replacing cycles-per-second as an indication of frequency.

600.6.1.91 Hi-pot. A test designed to determine the highest potential that can be applied to a conductor without breakdown of the insulation.

600.6.1.92 Hot tin dip. A process of passing bare wire through a bath of molten tin to provide a coating.

600.6.1.93 Hybrid cable assembly. Multiconductor cable assembly containing two or more types of components.

600.6.1.94 Impact strength. Test for ascertaining the punishment a cable configuration can withstand without physical or electrical breakdown, by impacting with a given weight, dropped a given distance, in a controlled environment.

600.6.1.95 Impedence. The total opposition that a circuit offers to the flow of alternating current or any varying current at a particular frequency. It is a combination of resistance R and reactance X, measured in ohms and designated by Z:

$$Z = \sqrt{R^2 + X^2}$$

600.6.1.96 Impulse strength. The voltage breakdown of insulation under voltage surges on the order of microseconds in duration.

600.6.1.97 Impulse test. An insulation test in which the voltage applied is an impulse voltage of specified wave shape.

600.6.1.98 Inductance. The property of a circuit or circuit element that opposes a change in current flow. Inductance thus causes current changes to lag behind voltage changes. Inductance is measured in henrys.

600.6.1.99 Insulated wire. A conductor of electricity covered by a nonconducting material.

WIRING HARNESES, MOLDED CABLE ASSEMBLIES,
HYBRID CABLE ASSEMBLIES, AND
CONVOLUTE TUBING CABLE ASSEMBLIES

600.6.1.100 Insulated grip. Certain crimp-type contacts having extended cylinders at the rear designed to accept a bare wire and a small length of its insulation. When crimped, both wire and insulation are held firmly in place.

600.6.1.101 Insulation resistance. The ratio of the applied voltage to the total current between two electrodes in contact with a specified insulator.

600.6.1.102 Insulator. A material of such low electrical conductivity that the flow of current through it can usually be neglected.

600.6.1.103 Integral belt. In a cable, a layer of insulation of semiconductive material applied usually by extrusion over two or more insulated, twisted, or parallel conductors, to form a round, smooth diameter.

600.6.1.104 Intercalated tapes. Two or more tapes, generally of different composition, applied simultaneously in such a manner that a portion of each tape overlies a portion of the other tape.

600.6.1.105 Interstice. A minute space between one thing and another, especially between things closely set or between the parts of a body.

600.6.1.106 Iron constantan. A combination of metals used in thermocouples, thermocouple wires, and thermocouple lead wires. Constantan is an alloy of copper, nickel, manganese, and iron. The iron wire is positive and the constantan negative.

600.6.1.107 Irradiation. The exposure of a material to high energy emissions. In insulations for the purpose of favorably altering the molecular structure.

600.6.1.108 Jacket. A rubber or synthetic covering, sometimes fabric reinforced, over the insulation core or sheath of a cable.

600.6.1.109 Junction. A point in a circuit where two or more wires or cable legs are connected.

600.6.1.110 Jute. A natural fiber of plant base formed into ropelike strands. Used in cables for filling the interstices to give a round cross-section.

600.6.1.111 Kilowatt. A unit of power equal to one thousand watts.

600.6.1.112 Kilovolt-ampere. 1000 volts x ampere.

600.6.1.113 Lacing cord. Cord or twine used for tying cable forms, hook-up wires, cable ends, cable bundles, and wiring harnesses. May also be used to hold cable together between layers.

600.6.1.114 Lacing tape. Flat flexible fabric tape for tying wiring harnesses and wire bundles.



WIRING HARNESSSES, MOLDED CABLE ASSEMBLIES,
HYBRID CABLE ASSEMBLIES, AND
CONVOLUTE TUBING CABLE ASSEMBLIES

600.6.1.115 Lay. The lay of any helical element of a cable is the axial length of a turn of the helix of that element. Lay is often referred to as "pitch".

600.6.1.116 Lap wrap. Tape wrapped around an object in an overlapping condition.

600.6.1.117 Loss index. The product of the power factor and the dielectric constant.

600.6.1.118 Low loss. Term applied to a dielectric material or cable that has a small amount of power loss over long lengths making it suitable for transmission of radio frequency energy.

600.6.1.119 Low-noise cable. Cable configuration specially constructed to eliminate spurious electrical disturbances caused by capacitance charges or self-generated noise induced by either physical abuse or adjacent circuitry.

600.6.1.120 Marker thread. A colored thread layer parallel and adjacent to the strands of an insulated conductor which identifies the wire manufacturer and sometimes the specification under which the wire is constructed.

600.6.1.121 MCM. Abbreviation for a thousand circular mils.

600.6.1.122 Melt index. Extrusion rate of a thermoplastic material through an orifice of specified conditions of time, temperature, and pressure.

600.6.1.123 Melt range. The difference in degrees F or C between melt point of material and its flow point.

600.6.1.124 Melt point. The point at which a material melts.

600.6.1.125 Modulus of elasticity. The ratio of stress to strain in a material that is elastically deformed.

600.6.1.126 Moisture absorption. Generally, the amount of moisture in percentage that an insulation will absorb under specified conditions.

600.6.1.127 Moisture resistance. The ability of a material to resist absorbing moisture from the air or when immersed in water.

600.6.1.128 Molecular weight. The weight of a molecule which is the sum of the weights of its constituent atoms.

600.6.1.129 Multiconductor. More than one conductor within a single cable complex.

WIRING HARNESSSES, MOLDED CABLE ASSEMBLIES,
HYBRID CABLE ASSEMBLIES, AND
CONVOLUTE TUBING CABLE ASSEMBLIES

600.6.1.130 Nickel. This metal offers a combination of corrosion resistance, formability, and tough physical properties. For these reasons, nickel is used for alloying purposes and in nickel-clad copper wire.

600.6.1.131 Non-conductor. An insulating material.

600.6.1.132 Picks per inch. The number of times the carriers in a braid cross over each other in the same direction along the longitudinal axis for each inch of length.

600.6.1.133 Red plague. A powdery brown-red corrosion sometimes found on silver-coated conductors and shield braids. It is fungus-like in appearance and will appear at random spots along the length of a conductor or shield. It most often occurs at the point of crossover in a shield or in the interstices of a stranded conductor.

600.6.1.134 Rubber. An elastomer capable of rapid elastic recovery. Specifically, natural rubber, the standard of comparison for elastomers.

600.6.1.135 Sheath. The outer covering or jacket over the insulated conductors to provide mechanical protection for the conductors.

600.6.1.136 Shield. A metallic layer placed over an insulated conductor or group of conductors to prevent electrostatic or electromagnetic interference between the enclosed wires and external fields. This shield can be braided wires, foil wrap, foil-backed tape, a metallic tube, or conductive vinyl or rubber. When a metallic braid is applied over insulated conductors, the shielding effectiveness is in proportion to the amount of coverage, usually expressed in percentage.

600.6.1.137 Skeleton braid. May be widely separated braid of fiber, copper, or steel. Used to hold core together, for reinforcing jacket, or for shielding.

600.6.1.138 Spurious signals. Undesired voltages in conductors caused by electro-magnetic or electrostatic coupling from other conductors or from external sources such as a transformer.

600.6.1.139 Tape. A relatively narrow, woven or cut, strip of fabric, paper, or film material.

600.6.1.140 Tape wrap. A term denoting spirally or longitudinally applied tape material wrapped around the wire, either insulated or uninsulated, and used as an insulation or mechanical barrier.

600.6.1.141 Tubing. Extruded non-supported plastic or elastomer material.

600.6.1.142 Voltage. The term most often used in place of electromotive force, potential, or voltage drop, to designate electric pressure that exists between two points and is capable of producing a flow of current when a closed circuit is connected between the two points.

MIL-STD-339(AT)
SECTION 600
WIRING HARNESSSES, MOLDED CABLE ASSEMBLIES,
HYBRID CABLE ASSEMBLIES, AND
CONVOLUTE TUBING CABLE ASSEMBLIES

600.6.1.143 Voltage drop. The amount of voltage loss from original input in a conductor of given size and length.

600.6.1.144 Wire. A slender rod or filament of drawn metal usually referring to any single conductor.

600.6.1.145 Wiring devices. The accessory parts and materials that are used in the installation of wiring such as terminals, connectors, junction boxes, conduit, clamps, insulation, and supports.

700.1 SCOPE

700.1.1 Scope. This section covers the fabrication of wiring harnesses.

700.2 APPLICABLE DOCUMENTS

700.2.1 Government documents.

700.2.1.1 Specifications and standards. The following specifications and standards form a part of this standard to the extent specified herein. Unless otherwise specified, the issues of these documents shall be those listed in the issue of the Department of Defense Index of Specifications and Standards (DODISS) and supplement thereto, cited in the solicitation.

SPECIFICATIONS
FEDERAL

HH-I-595 - Insulation Tape, Electrical,
Pressure-Sensitive Adhesive, Plastic.

MILITARY

MIL-I-631 - Insulation, Electrical, Synthetic-Resin
Composition, Nonrigid.
MIL-T-713 - Twine, Fibrous: Impregnated, Lacing and
Tying.
MIL-S-8516 - Sealing Compound, Polysulfide Rubber,
Electric Connectors and Electric Systems,
Chemically Cured.
MIL-C-13486 - Cable, Special Purpose, Electrical:
Low-Tension Heavy Duty Single-Conductor and
Multiconductor.
MIL-T-13513 - Terminal, Lug; Splice, Conductor
(Electrical, Solderless, for Automotive
Use).
MIL-I-15126 - Insulation Tape, Electrical Pressure
Sensitive Adhesive and Pressure Sensitive
Thermosetting Adhesive.
MIL-I-23053/1 - Insulation Sleeving, Electrical, Heat
Shrinkable, Polychloroprene, Flexible.
MIL-I-23053/5 - Insulation Sleeving, Electrical, Heat
Shrinkable, Polyolefin, Flexible,
Cross-Linked.

MIL-STD-339(AT)
SECTION 700
FABRICATION OF WIRING HARNESSSES

STANDARDS
MILITARY

- | | |
|-------------|--|
| MIL-STD-202 | - Test Methods for Electronic and Electrical Component Parts. |
| MIL-STD-454 | - Standard General Requirements for Electronic Equipment. |
| MS3367 | - Strap, Tiedown, Electrical Components, Adjustable, Self-Clinching, Plastic, Type I, Class 1. |
| MS27148 | - Contact; Pin, Electrical Connector: No. 12, 14 and 16 AWG. |

700.2.1.2 Other Government drawings. The following drawings form a part of this standard to the extent specified herein.

DRAWINGS
ARMY

- | | |
|---------|--|
| 7070301 | - Chart, Electrical Circuit Numbers 1 thru 199. |
| 8724206 | - Material Specification for Rubber Components of Electrical Connectors. |
| 8724762 | - Rod. |

(Copies of specifications, standards, handbooks, drawings, publications, and other Government documents required by the contractors in connection with specific acquisition functions should be obtained from the contracting activity or as directed by the contracting activity.)

700.2.2 Order of precedence. In the event of a conflict between the text of this standard and the references cited herein, the text of this standard shall take precedence.

700.3 REQUIREMENTS

700.3.1 Binding. Cables shall be bound together using one of the following methods:

- a. One-half overlapping turns of tape in accordance with HH-I-595, thickness .010 inch, width $3/4 \pm 1/4$ inch, color black or tape in accordance with MIL-I-15126, type EF-9, width $3/4 \pm 1/4$ inch, color black.
- b. One-half overlapping turns of insulation in accordance with MIL-I-631, type A or F, form Ts, grade A, class I, thickness .008 inch, width $3/4 \pm 1/4$ inch, color black. The insulation shall be wrapped in accordance with the best commercial practice and the ends shall be secured to prevent unraveling.

FABRICATION OF WIRING HARNESES

- c. One-half overlapping turns of tape to form 2-inch wrap lengths at approximately 10-inch spacings using tape in accordance with HH-I-595, thickness .010 inch, width $3/4 \pm 1/4$ inch, color black.
- d. Heat-shrinkable insulation sleeveings to form 1-inch lengths at approximately 10-inch spacings using insulation sleeving in accordance with MIL-I-23053/1, class optional, color black or insulation sleeving in accordance with MIL-I-23053/5, class 1 or 3, color optional.
- e. Strap at approximately 10-inch spacings using straps in accordance with MS3367-1, MS3367-2, or MS3367-4.

700.3.2 Crimping. Pin contacts (ferrules), terminals, and splicing connectors shall be crimped to cables (conductors and/or insulation) and shall meet the performance requirements of MIL-T-13513.

NOTE: Do not distort skirts of pin contacts (MS27148) when crimping to conductors.

700.3.3 Soldering. Conductors shall be soldered to pin and socket contacts and (solder-type) terminals and terminal assemblies in accordance with MIL-STD-454, requirement 5. Fittings and conduit shall be tinned and sweat-soldered together. Ends of fittings shall be soldered to conduit in accordance with MIL-STD-454, requirement 5. Inside edges of conduit shall be free from burrs and excess solder.

700.3.4 Splicing. Spliced conductors (crimped or soldered) shall meet the performance requirements of MIL-T-13513. Completed splices shall meet the "high voltage to ground (high potential)" requirement of MIL-C-13486 (except table V shall be used in lieu of table VI for voltages). Spliced conductors shall be adequately insulated and the insulation shall adhere to each cable's insulation when cable(s) is flexed. The following method for insulating spliced conductors meets the above insulation requirements:

Vulcanize using rubber in accordance with MIL-R-3065, synthetic, grade SC 515 or SC 615, A1, B1, C1, F1. Thickness of rubber over exposed conductors shall be $1/8$ to $5/32$ inch and is to overlap adjacent insulation for a distance of at least $3/16$ inch and a thickness of at least $1/32$ inch or as specified on the drawing.

NOTE: Other splicing methods may be used provided they meet all test requirements.

700.3.5 Spare grommet holes. All spare grommet holes shall be plugged with rod of diameter and length as required (see Drawing 8724762). Optional material: grommet material in accordance with Drawing 8724206.

700.3.6 Potting. Specified areas shall be potted with sealing compound in accordance with MIL-S-8516, class optional.

MIL-STD-339(AT)

SECTION 700

FABRICATION OF WIRING HARNESSSES

700.3.7 Lacing. Leads shall be laced together using twine in accordance with MIL-T-713, type P, waxed, class 2.

700.3.8 Identification of circuit numbers. Circuit numbers shall be identified in accordance with Drawing 7070301.

700.3.9 Continuity. Circuit continuity shall be as indicated in the wiring diagram (wiring table). Unless otherwise specified, the maximum allowable circuit resistance shall be 1 ohm. Unless otherwise specified, circuit continuity shall be tested in accordance with MIL-STD-202, method 303. 1/

700.3.10 Insulation resistance. Unless otherwise specified, the insulation resistance shall be at least 100 megohms and shall be measured in accordance with MIL-STD-202, method 302, test condition B (test potential 500 volts direct current). Unless otherwise specified, the electrification time shall be 5 seconds between any two circuits and between any circuit and the connector shells and/or shields. 1/

700.4 QUALITY ASSURANCE PROVISIONS

700.4.1 Inspections. Inspections shall be performed in accordance with the applicable military specification or drawing.

700.5 PACKAGING

700.5.1 Preservation, packaging, packing, and marking. Preservation, packaging, packing, and marking for the desired level shall be in accordance with the applicable drawing or packaging requirements specified by the contracting authority.

700.6 NOTES

700.6.1 Definitions. See section 600.

1/ Paragraphs 700.3.9 and 700.3.10 are applicable only if specifically designated as a requirement on the drawing.

MIL-STD-339(AT)
SECTION 800
FABRICATION OF WATERPROOF WIRING HARNESSSES

800.1 SCOPE

800.1.1 Scope. This section covers the fabrication of waterproof wiring harnesses.

800.2 APPLICABLE DOCUMENTS

800.2.1 Government documents.

800.2.1.1 Specifications and standard. The following specifications and standard form a part of this standard to the extent specified herein. Unless otherwise specified, the issues of these documents shall be those listed in the issue of the Department of Defense Index of Specifications and Standards (DODISS) and supplement thereto, cited in the solicitation.

SPECIFICATIONS
MILITARY

- | | |
|----------------|---|
| MIL-C-13486 | - Cable, Special Purpose, Electrical: Low-Tension Heavy Duty Single-Conductor and Multiconductor. |
| MIL-C-13486/1 | - Cable, Special Purpose, Electrical: Low Tension, Heavy Duty Single-Conductor Unshielded. |
| MIL-C-13486/2 | - Cable, Special Purpose, Electrical: Low Tension, Heavy Duty Single-Conductor Shielded. |
| MIL-C-13486/13 | - Cable, Special Purpose, Electrical: Low Tension, Heavy Duty Multiple Conductors Shielded. |
| MIL-T-13513 | - Terminal, Lug; Splice, Conductor (Electrical, Solderless, for Automotive Use). |
| MIL-I-23053 | - Insulation Sleeving, Electrical, Heat Shrinkable, General Specification for. |

STANDARD
MILITARY

- | | |
|--------|--|
| MS3367 | - Strap, Tiedown, Electrical Components, Adjustable, Self-Clinching, Plastic, Type I, Class 1. |
|--------|--|

2.1.2 Other Government drawings. The following other Government drawings form a part of this standard to the extent specified herein.

MIL-STD-339(AT)
SECTION 800
FABRICATION OF WATERPROOF WIRING HARNESSSES

DRAWINGS
ARMY

- 7070301 - Chart, Electrical Circuit Numbers 1 thru 199.
- 8724206 - Material Specification for Rubber Components of Electrical Connectors.
- 8724762 - Rod.

(Copies of specifications, standards, handbooks, drawings, publications, and other Government documents required by the contractors in connection with specific acquisition functions should be obtained from the contracting activity or as directed by the contracting activity.)

800.2.3 Order of precedence. In the event of a conflict between the text of this standard and the references cited herein, the text of this standard shall take precedence.

800.3 REQUIREMENTS

800.3.1 Materials. Unless otherwise specified on the drawing, equivalent or substitute materials shall not be used.

800.3.1.1 Cables. Cables shall be in accordance with MIL-C-13486. Shielded cables shall be in accordance with MIL-C-13486/2 or MIL-C-13486/13. The insulation color of cables shall be black.

800.3.1.1.1 Conductor/cable size. The conductor size of single conductor cables shall be #14 AWG with the cable size in accordance with MIL-C-13486/1, part number M13486/1-5, unless otherwise specified on the drawing, in which case the conductor size specified shall have a cable size in accordance with MIL-C-13486/1, part number as specified in table XXIII.

TABLE XXIII. Conductor/cable size.

Conductor size (AWG #)	Part number
16	M13486/1-3
12	M13486/1-7
10	M13486/1-8
8	M13486/1-9
6	M13486/1-10
4	M13486/1-11
2	M13486/1-12
1/0	M13486/1-14

800.3.1.2 Terminals and connectors. Terminals and connectors shall be as specified on the drawing.

FABRICATION OF WATERPROOF WIRING HARNESSSES

800.3.1.3 Heat-shrinkable insulation sleeving. Heat-shrinkable insulation sleeving shall be in accordance with MIL-I-23053 and shall cover exposed metal of the terminal barrel and extend over the cable insulation. Unless otherwise specified on the drawing, the color of heat-shrinkable insulation sleeving shall be black or red as specified on the drawing.

800.3.1.4 Braid. Unless otherwise specified on the drawing, braid shall be Engineering Yarns, Inc. #VN 4400 or equal.

800.3.1.5 Tape. (This space intentionally left blank.)

800.3.1.6 Loom. (This space intentionally left blank.)

800.3.1.7 Cable straps. Cable straps shall be in accordance with MS3367, color black (weather resistant).

800.3.2 Construction.

800.3.2.1 Tolerances for cable assemblies. Unless otherwise specified on the drawing, tolerances for cable assemblies shall be as specified in table XXIV.

TABLE XXIV. Tolerances for cable assemblies.

Cable length (inches, overall)	Tolerance		
	Leads extending from assembly covering (inches)	Covered sections of assembly (per section) (inches)	Overall length of cable assemblies (inches)
0 to 2	+ .20	+ .20	+ .30
over 2 to 6	+ .30	+ .30	+ .50
over 6 to 12	+ .40	+ .50	+ .80
over 12 to 36	+ .50	+ .60	+ 1.00
over 36 to 100	+ 1.00	+ .70	+ 1.50
over 100 to 200	+ 1.50	+ 1.00	+ 2.00
over 200	+ 2.00	+ 1.50	+ 3.00

800.3.2.2 Crimping. Unless otherwise specified on the drawing, terminals shall be machine crimped and shall meet the requirements of table I of MIL-T-13513.

800.3.2.3 Soldering. When specified on the drawing, terminals shall be soldered as follows:

- a. Standard production practice shall be used except soldering by carbon electrode shall not be used.
- b. Solder shall be SN60 with rosin core flux.

MIL-STD-339(AT)
SECTION 800
FABRICATION OF WATERPROOF WIRING HARNESSSES

- c. Soldered terminations shall exhibit minimum solder wicking, and insulation shall be applied to termination when and as specified on the drawing.
- d. Soldered joints shall exhibit no "cold solder" and shall not have sharp projections or excessive solder.
- e. Solder shall meet the performance requirements of MIL-T-13513.

800.3.2.4 Splicing. Unless otherwise specified on the drawing, harness wires shall not be spliced. When specified on the drawing, splices shall be equally spaced within the dimension shown on the drawing. If more than one splice is specified between dimensioning points, at least 2.0 inches spacing is required between splices. Splices shall be made by crimped splice band, soldered as specified in paragraph 800.3.2.3. Completed splices shall meet the following requirements of MIL-C-13486:

- a. High voltage to ground (high potential).
- b. Fungus resistance.
- c. Resistance to oil absorption.
- d. Resistance to immersion in liquids.
- e. Flammability.
- f. Resistance to ozone.
- g. High-temperature resistance.

Spliced conductors shall be adequately insulated and the insulation shall adhere to each cable's insulation when cable(s) is flexed. The method specified in paragraph 700.3.4 for insulating spliced conductors meets the above insulation requirements.

800.3.2.5 Spare grommet holes. All unused holes in connector sealing grommets shall be plugged with nonconductive rod of diameter and length as required.

800.3.2.6 Stripping. Wires mechanically or manually stripped shall not have nicks or broken strands. The length of strip shall be adjusted to the terminal manufacturer's specifications. Terminations with nicked or broken strands shall be removed and reterminated.

800.3.2.7 Braiding. Braid shall be tightly woven around conductors and shall not fall below 12 to 16 picks per inch in any area. Braid shall be continuous and terminate as specified on the drawing. Circuit numbers shall be visible between the braid terminating point and the terminal or connector. All ends, including openings around takeouts, shall be securely anchored to prevent material from sliding back on conductors upon installation into the vehicle. Braid termination shall be covered by heat-shrinkable tubing or tape.

FABRICATION OF WATERPROOF WIRING HARNESES

800.3.2.8 Taping. Tape shall be wrapped with at least a one-third overlap while the cables are under a tension of 6 to 8 pounds. All ends of nonadhesive backed vinyl tape shall be tied and trimmed, consistent with good workmanship, to prevent raveling. The length of tails shall be not greater than 1.5 inches.

800.3.2.9 Loom. Loom shall not be slit, except at breakouts, and shall be continuous and permanently affixed at the location specified on the drawing.

800.3.2.10 Circuit identification. Circuits shall be identified in accordance with MIL-B-43436 and table XXV. Metal bands shall be located not greater than 2 inches from each end of wires. When visually examined at a distance of 14 inches, each character of marking shall be uniform, clear, and easily identified as an accurate duplication of the printing type (hand etching shall not be used).

TABLE XXV. Circuit identification.

Conductor/cable size	Circuit no. band	Type
#16 AWG; M13486/1-3 and #14 AWG; M13486/1-5	M43436/3-1	3 leg
#12 AWG; M13486/1-7 and #10 AWG; M13486/1-8	M43436/2-1	2 leg
#8 AWG; M13486/1-9 thru #1/0 AWG; M13486/1-14	M43436/1-3	Belt

800.3.2.11 Wiring harness identification. Wiring harnesses shall be identified as specified in section 900.

800.4 QUALITY ASSURANCE PROVISIONS

800.4.1 Inspections. Inspections shall be performed in accordance with the applicable military specification or drawing.

MIL-STD-339(AT)
SECTION 800
FABRICATION OF WATERPROOF WIRING HARNESSSES

800.5 PACKAGING

800.5.1 Preservation, packaging, packing, and marking. Preservation, packaging, packing, and marking for the desired level shall be in accordance with the applicable drawing or packaging requirements specified by the contracting authority.

800.6 NOTES

800.6.1 Definitions. See section 600.

MIL-STD-339(AT)
SECTION 900
WIRING PRACTICES INSIDE ENCLOSURES
(-94 TO +257°F)

900.1 SCOPE

900.1.1 Scope. This section covers practices to be used in the fabrication of wiring assemblies which will be operating inside enclosures in normal vehicle environments with worst case ambient temperatures of -94 to +257°F.

900.2 APPLICABLE DOCUMENTS

900.2.1 Government documents.

900.2.1.1 Specifications and standards. The following specifications and standards form a part of this standard to the extent specified herein. Unless otherwise specified, the issues of these documents shall be those listed in the issue of the Department of Defense Index of Specifications and Standards (DODISS) and supplement thereto, cited in the solicitation.

SPECIFICATIONS
MILITARY

- | | |
|-------------|--|
| MIL-I-631 | - Insulation, Electrical, Synthetic-Resin Composition, Nonrigid. |
| MIL-I-23053 | - Insulation Sleeving, Electrical, Heat Shrinkable, Flexible. |
| MIL-M-81531 | - Marking of Electrical Insulating Materials. |

STANDARD
MILITARY

- | | |
|-------------|---|
| MIL-STD-454 | - Standard General Requirements for Electronic Equipment. |
|-------------|---|

(Copies of specifications and standards required by the contractors in connection with specific acquisition functions should be obtained from the contracting activity or as directed by the contracting activity.)

900.2.2 Order of precedence. In the event of a conflict between the text of this standard and the references cited herein, the text of this standard shall take precedence.

900.3 REQUIREMENTS

900.3.1 Equipment.

900.3.1.1 Wire stripper. Manual or automatic wire stripping equipment shall be of sufficient quality to conform to the requirements of 900.3.3.1.

900.3.1.2 Solder equipment. Manual or automatic soldering equipment shall be of sufficient quality to conform to the requirements of 900.3.3.2 and requirement 5 of MIL-STD-454.

WIRING PRACTICES INSIDE ENCLOSURES
(-94 TO +257°F)

900.3.1.3 Crimper. Manual or automatic crimping equipment shall be of sufficient quality to conform to the requirements of 900.3.3.3.

900.3.1.4 Wire cutter. Manual or automatic wire cutting equipment shall be of sufficient quality to conform to the requirements of 900.3.3.4.

900.3.1.5 Wire marking. Wire marking equipment shall be sufficient to provide at least one of the following markings:

- a. Hot stamp not less than 0.050-inch height lettering in accordance with MIL-M-81531 on heat-shrinkable sleeving conforming to MIL-I-23053/5, class 1 or MIL-I-631, type F, form U, grade C, class 1.
- b. Hot embossed marking not less than 0.050-inch height letters directly on the wire only when such equipment is part of a standard wire cutting/stripping/marketing machine.

The wire marking equipment shall be of sufficient quality to conform to the requirements of 900.3.3.5.

900.3.2 Materials.

900.3.2.1 Heat-shrinkable sleeving and breakouts. The heat-shrinkable protective materials shall conform to MIL-I-23053/5, class 1. All cleaners, primers, and adhesives used in a single assembly shall be those materials manufactured by or recommended by the manufacturer of the heat-shrinkable parts.

900.3.2.2 Solder. The solder shall conform to requirement 5 of MIL-STD-454.

900.3.2.3 Markers, assembly and wire. The assembly and wire marker(s) shall be as specified on the detail drawing; if not shown on the detail drawing, the marker shall be heat-shrinkable sleeving conforming to MIL-I-23053/5, class 1, or MIL-I-631, type F, form U, grade C, class 1.

900.3.2.4 Marking. Reference designation or wire termination identification, when required by applicable drawings, shall be applied to conductors by marker sleeves, marker bands, or by any suitable means that will satisfy 900.3.2.4.1.

900.3.2.4.1 Permanency. The marking and method of securing shall be as permanent as the normal life expectancy of the cable or conductor to which it is applied. The marking and its method of securing shall be capable of withstanding all environmental and functional tests specified for the equipment in which it is installed.

MIL-STD-339(AT)
SECTION 900
WIRING PRACTICES INSIDE ENCLOSURES
(-94 TO +257°F)

900.3.2.4.2 Lettering style, size, and color. Letters shall be sans-serif Gothic capitals, and numerals shall be Arabic. The letters and numerals shall be legible and of a size consistent with the size of wire or sleeving. The color used for marking shall be a contrasting color to that on which it is applied.

900.3.2.4.3 Conductor marker location. The marking shall be placed as near the conductor termination as possible.

900.3.2.5 End connections. The end connections shall be as shown on the detail drawing.

900.3.3 Required procedures and operations.

900.3.3.1 Stripping. The length of the strip shall be as specified for the particular method of termination. Visually the strip shall be neat and clean. The number of nicked or severed strands shall be less than or equal to the maximum number shown in table XXVI.

TABLE XXVI. Nicked or severed strands.

Number of strands in wire	Allowable maximum number of nicked or severed strands
1 to 6	0
7 to 15	1
16 to 18	2
19 to 25	3
26 to 36	4
37 to 40	5
Over 40	6

900.3.3.2 Soldering. The soldering shall conform to requirement 5 of MIL-STD-454. Lack of luster is not a defect unless, when more carefully viewed, a structural defect is determined to exist.

900.3.3.3 Crimping. Crimps shall be made only with certified MS tooling matching the MS part being crimped or with the part manufacturer's recommended or required tool. For uninsulated crimped parts, no cracks in the part shall be allowed and no tool-inflicted damage (holes, tears, or cracks) shall be allowed. For stranded wire, all strands shall be enclosed in the crimped joint; no uncrimped or loose strands shall be allowed.

900.3.3.3.1 Two-conductor crimp termination. When terminating two conductors at the crimp contact or terminals, the procedure will vary in accordance with whether or not the combined diameters of the wires will fit into the insulation support portion of the crimp contact or terminal. The procedures are as follows:

MIL-STD-339(AT)
SECTION 900
WIRING PRACTICES INSIDE ENCLOSURES
(-94 TO +257°F)

- a. When combined diameters of both wires and conductors will fit into the appropriate portions of the crimp contact or terminal, strip the individual wires of insulation to a length approximately equal to "A" in figure 20. Insert the wires into the crimp contact or terminal until the conductors are visible through the inspection hole. Crimp the contact as appropriate.

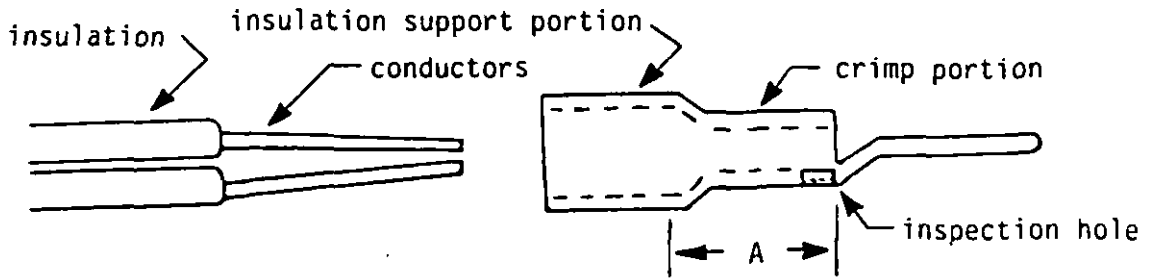

FIGURE 20. First two-conductor method using typical terminal.

- b. When the combined diameters of the conductors will fit into the crimp portion of the crimp contact or terminal, but the combined diameters of the wires slightly exceed the capacity of the insulation support portion of the crimp contact or terminal, strip the individual wires of the insulation to a length approximately equal to "B" in figure 21. Insert the wires into the crimp contact or terminal, forcing the insulation in as far as possible. Crimp the contact as appropriate.

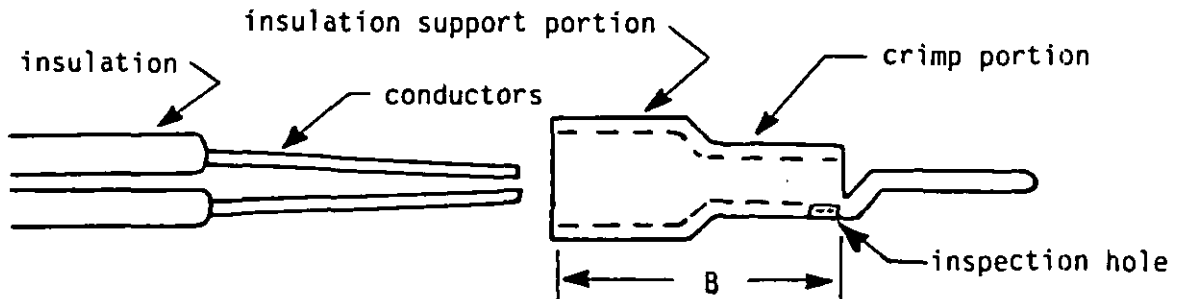

FIGURE 21. Second two-conductor method using typical terminal.



WIRING PRACTICES INSIDE ENCLOSURES

(-94 TO +257°F)

900.3.3.4 Wire cutting. The wire shall be measured and cut so that the assembly will conform to the dimensional and tolerance requirements shown on the detail drawing. Allowance shall be made for calculated wire-cut lengths since detail drawings generally show finished assembly dimensions, and out-of-tolerance lengths on the finished assembly are not acceptable (see 900.3.3.6).

900.3.3.5 Marking. The assembly and wires shall be marked as shown on the detail drawing using one of the methods required in 900.3.1.5 and 900.3.2.3. All marks shall be clearly legible and the marker(s) neatly installed.

900.3.3.6 Dimensional tolerances. The dimensional tolerances shall be according to the detail drawing. If there is no specific requirement on the detail drawing, the tolerances shall be as shown in table XXVII.

TABLE XXVII. Dimensional tolerances.

Total length (inches)	Tolerance (inches)
0 to 2	+ 0.38
over 2 to 6	+ 0.50
over 6 to 12	+ 0.75
over 12 to 36	+ 1.00
over 36 to 100	+ 2.00
over 100 to 200	+ 3.00
over 200	+ 4.00

Angular tolerances shall be ± 5 degrees if none is shown on the detail drawing.

900.3.3.7 Arrangement. Groups of wires should be arranged as a harness in order to facilitate dressing and assembly. Individual wires of such a harness shall run parallel to one another, and shall break off at right angles to the harness (see 900.3.3.7.5). The longer wires of the group shall be in the center.

900.3.3.7.1 Bundling techniques. Lacing is the most common method of grouping wires as a harness. Lacing shall start at one end of the harness and shall proceed as outlined herein. Breakoffs of two or more wires shall also be laced. Lacing shall not be used to fasten a harness to a chassis, in lieu of clamps. Either spot tie in accordance with 900.3.3.7.2 or lockstitch in accordance with 900.3.3.7.3 is acceptable.

900.3.3.7.2 Starting tie and spot tie. Lacing shall be started with the tie shown in figure 22. The starting tie shall be of this configuration whether single- or double-strand cord is used for lacing.

WIRING PRACTICES INSIDE ENCLOSURES
 (-94 TO +257°F)

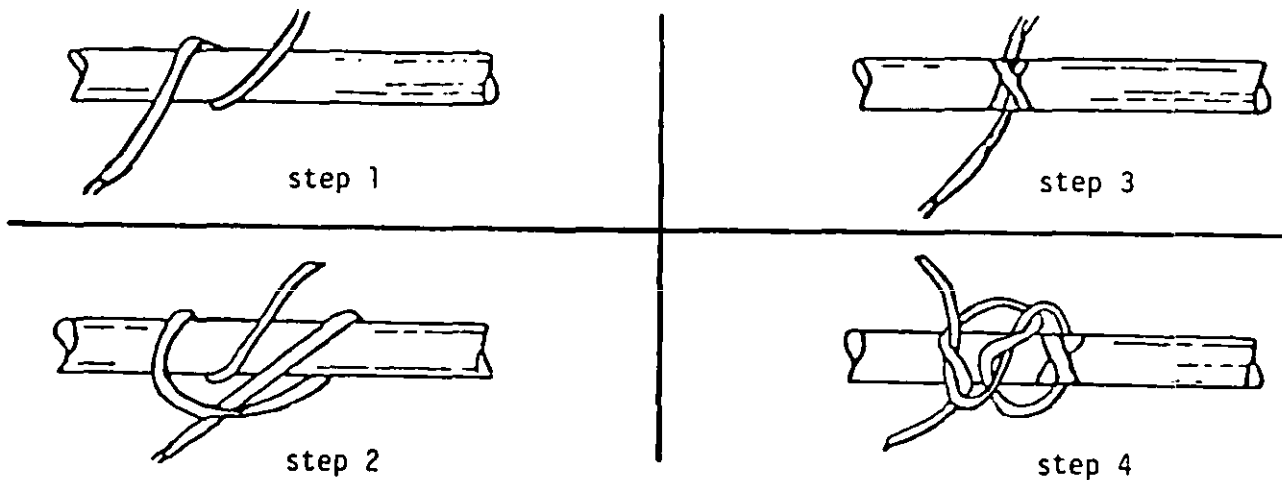

FIGURE 22. Starting tie and spot tie.

900.3.3.7.3 Lockstitches. Lockstitches shall consist of the overhand tie as shown in figure 23. Such lockstitches should be located approximately 1/2 inch apart, or as otherwise indicated by the size and configuration of the harnesses.

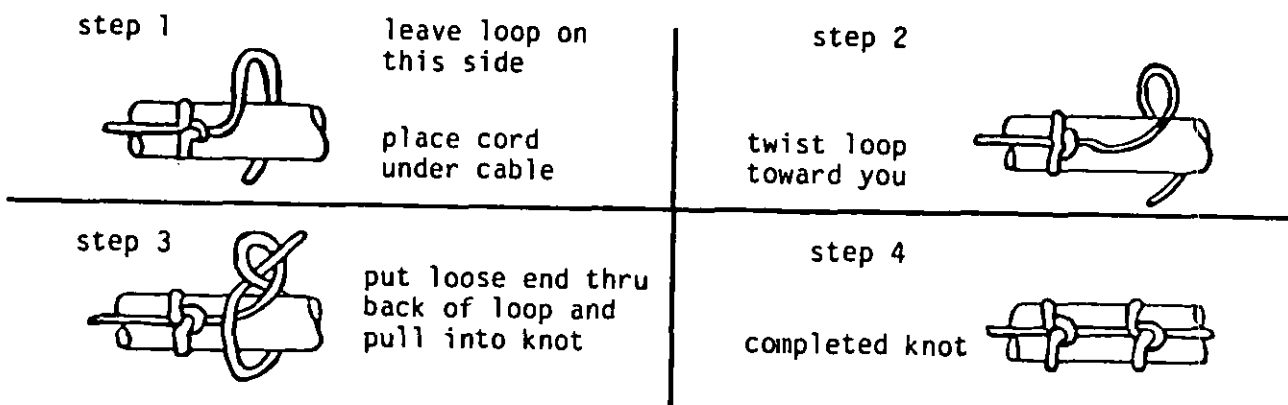

FIGURE 23. Overhand tie.

MIL-STD-339(AT)
 SECTION 900
 WIRING PRACTICES INSIDE ENCLOSURES
 (-94 TO +257°F)

900.3.3.7.4 Finishing tie. The finishing tie shall be as shown in figure 24. The finishing tie should be placed within 1-1/2 inches of the harness or wire termination.

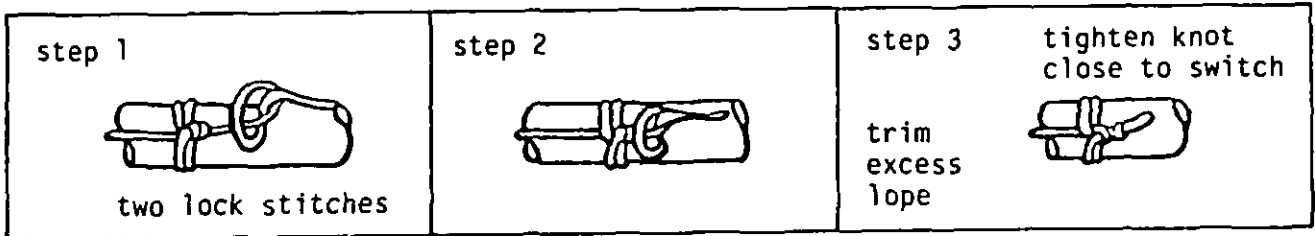

FIGURE 24. Finishing tie.

900.3.3.7.5 Breakoffs. A breakoff is any lead or combination of leads that flows at right angles to the main flow of the harness. Such breakoffs shall be so arranged as not to cause a large variation in the distance between lockstitches. A lead breakoff shall follow a lockstitch, as shown in figure 25.

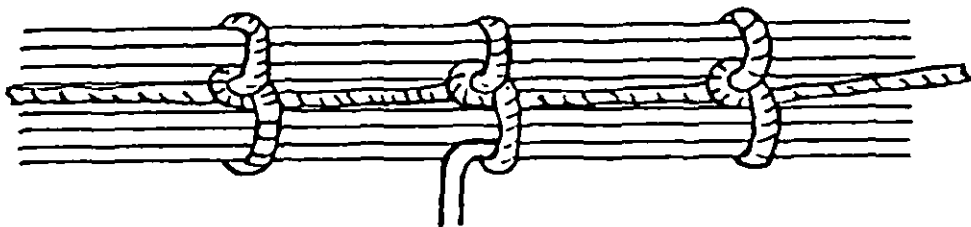

FIGURE 25. Lead breakoff.

900.3.3.7.6 Spacing. Ties and laces shall be spaced as shown in table XXVIII.



WIRING PRACTICES INSIDE ENCLOSURES
(-94 TO +257°F)

TABLE XXVIII. Spacing.

Bundle diameter (inches)	Average spacing (inches)
0 to 0.25	0.75
over 0.25 to 0.50	1.50
over 0.50 to 1.00	2.00
over 1.00	3.00

900.3.3.8 Shield terminations. Shielded wire shall be terminated by the severed wire termination method. Termination shall start by cutting the insulation jacket to the length required for the termination of the conductors as shown in figure 26A. Unwrap the shield from the conductor(s) and twist it with a ground wire as shown in figure 26B. The resulting wire shall be folded back and insulated with heat-shrinkable tubing as shown in figure 26C. Wire ends shall be prepared for connection as specified in 900.3.3.1.

900.3.3.9 Two-conductor termination. When two conductors must terminate at the same solder cup, the soldering procedure shall be as specified herein.

900.3.3.9.1 Variations. Pre-soldering procedures vary in accordance with the combined size of the conductors, and with the space available for termination. These are the conditions in which the pre-soldering procedure will vary: (a) the combined conductors will fit into the solder cup and space is no problem; (b) the combined conductors exceed the capacity of the solder cup and space is no problem; and (c) the combined conductors exceed the capacity of the solder cup and space is limited. For condition (a), the recommended pre-soldering procedure is the "normal" method; for condition (b), the "adapter" method; and for condition (c), the "offset" method. Neither the "adapter" nor the "offset" method shall be used, however, unless an adequate means exists to relieve any strain that may be placed on the conductors emerging from the solder cup.

900.3.3.9.2 Wire preparation. Individual wires shall be prepared for termination as specified in 900.3.3.1, except that stripped conductors shall not be tinned.

900.3.3.9.3 Normal method. In cases in which the combined conductors will fit into the solder cup, and in which there is no important space problem, two-conductor solder termination shall proceed as follows:

- a. Twist the two conductors together, then tin them.
- b. Slip insulated sleeving over the twisted conductors, and push the sleeving back on their insulation, as shown in figure 27.

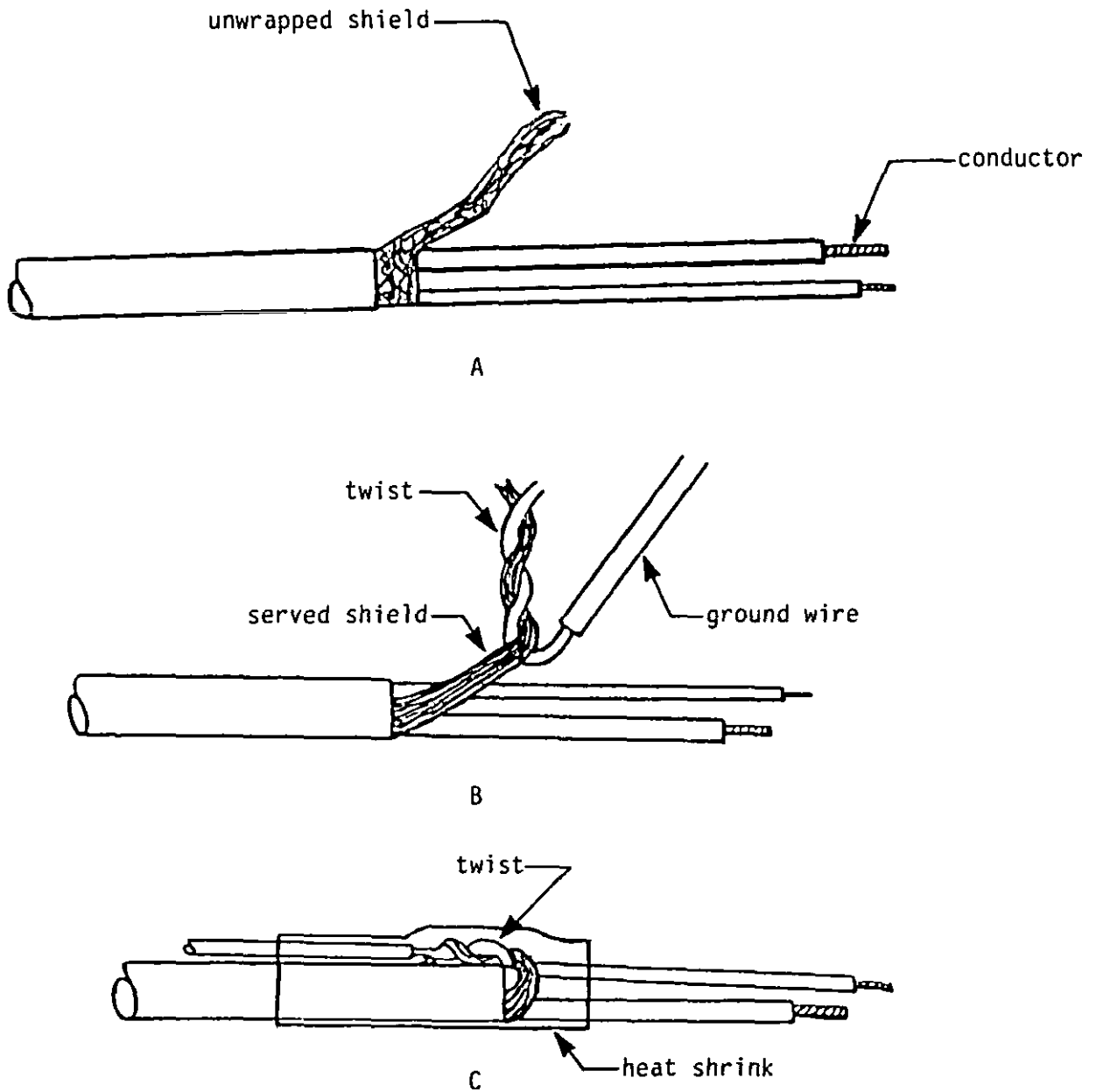

FIGURE 26. Wrap around.

MIL-STD-339(AT)
SECTION 900
WIRING PRACTICES INSIDE ENCLOSURES
(-94 TO +257°F)

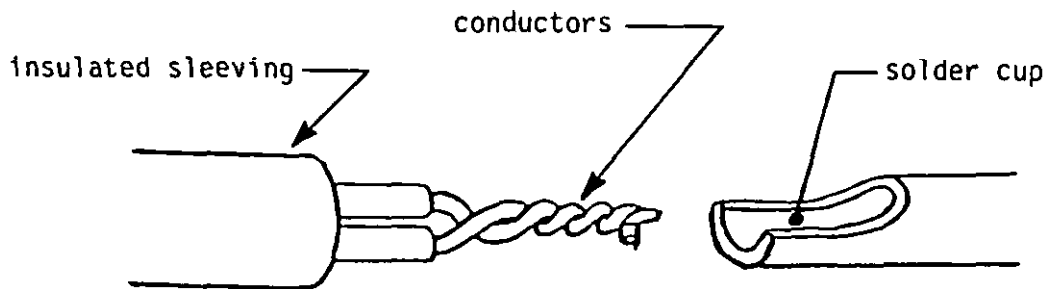

FIGURE 27. Normal method.

- c. Solder the conductors to the solder cup, then slip the insulated sleeving forward to cover the solder terminal.

900.3.3.9.4 Adapter method. In cases in which the combined conductors exceed the capacity of the solder cup, in which there is no important space problem, and in which the wires can be relieved of strain, two-conductor solder termination shall proceed as follows:

- a. Twist the two conductors together, then tin them.
- b. Slip insulated sleeving over the twisted conductors, and push the sleeving back on their insulation, as shown in figure 28.
- c. Insert the twisted conductors in the metal adapter as shown in figure 28. then either solder or crimp the adaptor, depending on the type being used. Solder the adaptor to the solder cup, then slip the insulated sleeving forward to cover the solder terminal.

WIRING PRACTICES INSIDE ENCLOSURES
(-94 TO +257°F)

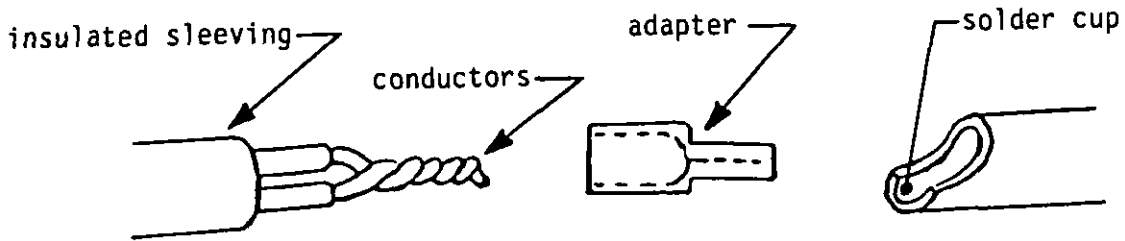

FIGURE 28. Adaptor method.

900.3.3.9.5 Offset method. In cases in which the combined conductors exceed the capacity of the solder cup, in which space is at a premium, and in which the wires can be relieved of strain, two-conductor termination shall proceed as follows:

- a. Wrap on conductor around the other as shown in figure 29. Tin the conductors. The smaller wire shall always be wrapped around the larger.

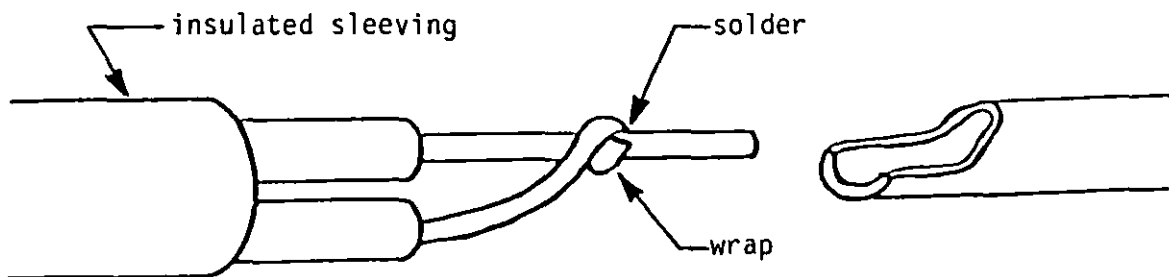

FIGURE 29. Offset method.

- b. Slip insulated sleeving over the twisted conductors, and push the sleeving back on their insulation, as shown in figure 29.

SECTION 900
WIRING PRACTICES INSIDE ENCLOSURES
(-94 TO +257°F)

- c. Solder the conductors to the solder cup, then slip the insulated sleeving forward to cover the solder terminal.

900.4 QUALITY ASSURANCE PROVISIONS

900.4.1 Inspections. Inspections shall be performed in accordance with the applicable military specification or drawing.

900.5 PACKAGING

900.5.1 Preservation, packaging, packing, and marking. Preservation, packaging, packing, and marking for the desired level shall be in accordance with the applicable drawing or packaging requirements specified by the contracting authority.

900.6 NOTES

900.6.1 Definitions. See section 600.

MIL-STD-339(AT)
SECTION 1000
IDENTIFICATION OF CABLE ASSEMBLIES

1000.1 SCOPE

1000.1.1 Scope. This section covers the identification of cable assemblies.

1000.2 APPLICABLE DOCUMENTS

1000.2.1 Government documents.

1000.2.1.1 Specification and standards. The following specification and standards form a part of this standard to the extent specified herein. Unless otherwise specified, the issues of these documents shall be those listed in the issue of the Department of Defense Index of Specifications and Standards (DODISS) and supplement thereto, cited in the solicitation.

SPECIFICATION
MILITARY

MIL-I-43553 - Ink, Marking, Epoxy Base.

STANDARDS
MILITARY

MIL-STD-130 - Identification Marking of US Military Property.

MIL-STD-1285 - Marking of Electrical and Electronic Parts.

(Copies of specifications, standards, handbooks, drawings, publications, and other Government documents required by the contractors in connection with specific acquisition functions should be obtained from the contracting activity or as directed by the contracting activity.)

1000.2.2 Order of precedence. In the event of a conflict between the text of this standard and the references cited herein, the text of this standard shall take precedence.

1000.3 REQUIREMENTS

1000.3.1 Introduction. Various information is required to be marked on every cable assembly. The information required and the method to be used for identification are usually stated in the procurement document. Two standards used for marking for military use are MIL-STD-130 and MIL-STD-1285.

1000.3.2 Information. The information, sequence, division, and line spacing are per the procurement document. However, it may deviate in order to accommodate the part configuration, any peculiarities, or a lack of space.

MIL-STD-339(AT)
SECTION 1000
IDENTIFICATION OF CABLE ASSEMBLIES

Some typical information that could be required would be:

- ... Identifying number.
- ... Design activity code.
- ... Serial.
- ... Contractor code.
- ... Government part number.
- ... Date code.
- ... Lot symbol.

1000.3.3 Methods. There are many methods of identification marking, but the two most commonly used methods for marking cable assemblies are "ink marking" and "impression marking." The method used should be the process that will not affect the function of the part or assembly that is being marked. Note that paper labels are not an acceptable method for identification marking of any kind since they will not meet most environmental requirements.

1000.3.3.1 Ink marking. The following is the most commonly used method of marking cable: Ink marking is applied to the outer covering of the assembly or on a piece of shrink tube or tape that will be permanently attached to the assembly. With any kind of ink marking, it is essential that the surface to be marked be thoroughly cleaned prior to marking.

1000.3.3.1.1 Ink. The ink used is to be of a quality that insures permanency and will have the same life expectancy as the assembly to which it is applied. It should also be nonfading and able to withstand the same environmental requirements that the assembly must withstand. Ink in accordance with MIL-I-43553 meets the above requirements.

1000.3.3.1.2 Color. The color of the ink, unless specified, should be a contrasting color to the surface to which it is applied for ease of recognition and legibility.

1000.3.3.1.3 Characters. The character size, unless specified, should be a size that is legible and suitable to fit the space available. The characters are to be CAPITAL letters and sans serif (i.e., Gothic or Futura). Any numerals used should only be identified with Arabic numbers.

1000.3.3.2 Impression marking. This type of identification marking can be accomplished by the use of metal or plastic tags. The information on these tags can be molded in, impression stamped, or ink marked. The tag is to be attached to the assembly by a method that will eliminate the possibility of the tag falling off.

Impression marking can also be applied directly to exposed surfaces of metal components. The same rules of size and character type apply to impression marking as well as ink marking (see 900.3.3.1.3).

1000.4 QUALITY ASSURANCE PROVISIONS

1000.4.1 Inspections. Inspections shall be performed in accordance with the applicable military specification or drawing.

MIL-STD-339(AT)
SECTION 1000
IDENTIFICATION OF CABLE ASSEMBLIES

1000.5 PACKAGING

1000.5.1 Preservation, packaging, packing, and marking. Preservation, packaging, packing, and marking for the desired level shall be in accordance with the applicable drawing or packaging requirements specified by the contracting authority.

1000.6 NOTES

1000.6.1 Definitions. See section 600.

IN-PROCESS AND ACCEPTANCE TESTING
OF CABLE ASSEMBLIES

1100.1 SCOPE

1100.1.1 Scope. This section provides the guidelines for electrical, physical, and environmental in-process and acceptance testing of cable assemblies.

1100.2 APPLICABLE DOCUMENTS

1100.2.1 Government documents.

1100.2.1.1 Standard. The following standard forms a part of this standard to the extent specified herein. Unless otherwise specified, the issue of this document shall be that listed in the issue of the Department of Defense Index of Specifications and Standards (DODISS) and supplement thereto, cited in the solicitation.

STANDARD
MILITARY

MIL-STD-202

- Test Methods for Electronic and Electrical
Component Parts.

(Copies of specifications, standards, handbooks, drawings, publications, and other Government documents required by the contractors in connection with specific acquisition functions should be obtained from the contracting activity or as directed by the contracting activity.)

1100.2.2 Order of precedence. In the event of a conflict between the text of this standard and the references cited herein, the text of this standard shall take precedence.

1100.3 REQUIREMENTS

1100.3.1 Introduction.

- a. All personnel involved in the testing of electrical wiring shall be properly instructed to operate the test equipment and adequately trained to carry out the test procedures.
- b. Tests shall be performed in accordance with applicable cable specifications or engineering drawings.
- c. Components and parts subject to possible damage from test voltage shall be electrically isolated before performing electrical tests.

IN-PROCESS AND ACCEPTANCE TESTING
OF CABLE ASSEMBLIES

- d. Uncoupled plug and receptacle connectors of production cables shall be protected with metal or plastic dust caps. Plastic dust caps shall fit snugly over the coupling ring of plug connectors and over the mating end of receptacle connectors. In no case shall dust caps come in contact with RFI grounding fingers in plug connectors.
- e. A probe, test lead, clip, etc., shall not be permitted to touch or be attached to the mating area of any connector pin or socket contact on any production cable.
- f. Connector shall be examined for alignment and straightness of contacts and possible damage resulting from testing. Gauges that may be used for checking contact alignment and straightness shall not damage contacts.

1100.3.2 Responsibility for testing. Unless otherwise specified in the contract or purchase order, the contractor is responsible for the performance of all test requirements. Except as otherwise specified in the contract or purchase order, the contractor may use his own or any other facilities suitable for the performance of the testing requirements specified, unless disapproved by the Government.

1100.3.3 Qualification testing. All cable assemblies procured by the Government shall be qualified. Qualification testing shall be performed at a laboratory satisfactory to the qualifying Government activity.

1100.3.4 Acceptance testing. All cable assemblies shall meet the test requirements specified in the applicable cable specification or engineering drawing. Lot size and lot rejection shall be specified within the specification or drawing.

1100.3.5 Electrical testing. All cable assemblies shall be electrically tested as part of the acceptance test requirements. As a minimum, the cables shall be tested for continuity, Dielectric Withstand Voltage (DWV), and insulation resistance. A standard used for electrical testing for military use is MIL-STD-202.

1100.3.5.1 Continuity. The continuity of all wires and nondeadended shields shall be tested. The test current shall not exceed 500 milliamperes. Measurements of quantitative electric resistance values are not required.

1100.3.5.2 DWV. Dielectric withstand tests shall be performed in accordance with the applicable cable specification or engineering drawing. Wiring which fails dielectric withstand tests shall be rejected. Failed wiring is that which exhibits any of the following:

IN-PROCESS AND ACCEPTANCE TESTING
OF CABLE ASSEMBLIES

- a. Dielectric breakdown (puncture).
- b. Flashover.
- c. Excessive current based on similar cables.
- d. Sudden increase in test current.

1100.3.5.3 Insulation resistance. An insulation resistance test shall be performed on all cable assemblies in accordance with the applicable cable specification or engineering drawing. The time of electrification shall be not greater than 1 minute.

1100.3.6 Physical testing (mechanical). Typical physical tests are cold-bend, impact, torque, twist, and bend. Cables should be flexible so that they can be shipped or stored on reels or coils and can withstand flexing during installation and use. Mechanical characteristics will not be discussed in detail since each specific design will produce a different set of parameters. Although it is difficult to specify a set of mechanical test requirements suitable for all cable constructions, the following paragraphs will explain the purpose of mechanical tests and a capsule description of the test.

1100.3.6.1 Cold-bend test. A cold-bend test is performed on a cable to determine if all materials used are compatible with the lowest operating temperature required, and whether processing has been correct; i.e., is the cable structurally engineered to withstand a bend at the lowest operating temperature, and what effect will sub-zero temperatures and severe bending have on the cable electrically? The majority of tests for cold-bend require a mandrel diameter that is 10 times the overall diameter of the cable. The cable is usually arranged so that one end is attached to a mandrel and a carefully selected weight is attached to the free end of the cable. The attached end of the cable should be wound at least one turn on the mandrel prior to reducing the temperature.

NOTE: If the cable is to be flexed at reduced temperature during operation, then the test should be conducted at the extreme low temperature; however, if the cable is static at low temperature, then the cable should be soaked at low temperature and then brought back to ambient before testing. Sudden sharp bends, or rapid unreeling of cable at lowered temperature, may shatter a cable that has passed the cold-bend test at identical temperatures under controlled speeds.

1100.3.6.2 Impact test. The impact test - whether performed at room temperature, elevated temperature, or lowered temperature - is designed to show the results of continuous, measured impact on cable materials, and how this controlled impact affects a cable electrically. In some cases, an impact on a cable would show no injurious effect on the cable sheath but, with improper internal construction, could break or damage one or more of the internal components, causing electrical short circuits or conductors to open.

The impact test consists of a weight dropped on a cable section for a specific number of cycles. The weight load is determined by the diameter of the cable being tested and will vary from 10 to 27 pounds.

IN-PROCESS AND ACCEPTANCE TESTING
OF CABLE ASSEMBLIES

1100.3.6.3 Torque test. The torque test is designed to find the force required to twist or bend a cable at a specified temperature, usually the lowest temperature at which a cable will be handled. The test data sought is how flexible a cable construction is at a given temperature. This is generally accomplished by use of a torque wrench attached to a mandrel end outside the environmental test chamber, with the cable arranged as for the cold-bend test. This test must be run through once at the specified temperature without the cable, to determine the amount of friction of the apparatus.

1100.3.6.4 Twist test. A twist test is concerned with how many twists of a given nature can be absorbed by a specimen before destruction. This test is accomplished by attaching a given weight to the free end of the specimen and twisting the weight, which in turn rotates one end of the specimen a given amount with respect to the other end. During the test, voltage is imposed between all conductors and shields, with alternate wires tied electrically in series, to determine when conductor failure or short circuit occurs. This test may be conducted at any required temperature.

1100.3.6.5 Bend test. The majority of multiconductor bend (or flex) tests are run on the basis of a 90° bend in one direction and a 90° bend in the opposite direction. This series of bends or flexes constitutes one cycle.

This test is used to ascertain how many bends a cable construction will absorb before destruction. The first deterioration likely to appear is conductor breakage or sheath cracking. The same electrical test should be conducted during bend test as was conducted during twist test.

1100.3.7 Environmental testing. This series of tests deals with the various conditions that the cable assembly, when in operation, will encounter. The results will determine whether or not the assembly along with the components, materials, and finishes is able to meet the level of acceptance necessary to ensure a minimal number of failures and repairs. The following paragraphs will review some of the typical tests that may be required.

1100.3.7.1 High-impact shock test. This test is performed for the purpose of determining the ability of various parts to withstand shock of the same severity as that produced by underwater explosions, collision impacts, near-miss gunfire, blasts caused by air explosions, and field conditions. Exact simulation of some of the severe shock motions experienced in the field is difficult to reproduce; however, parts that successfully complete this test method have been found to possess the necessary ruggedness for this use. The test apparatus utilized in this method is the same as that designated as Shock Testing Machine for Lightweight Equipment, Shock Tests, HI (High-Impact), Shipboard Machinery, Equipment and Systems, Requirements for. The purpose of this apparatus is to determine the ability of equipment installed aboard naval ships to withstand shock and still continue to perform its operational function. This test method is limited to testing of parts weighing not more than 300 pounds.

MIL-STD-339(AT)
SECTION 1100
IN-PROCESS AND ACCEPTANCE TESTING
OF CABLE ASSEMBLIES

1100.3.7.2 Vibration test. The vibration test is used to determine the effects on component parts of vibration within the predominant frequency ranges and magnitudes that may be encountered during field service. Most vibration encountered in field service is not of a simple harmonic nature, but tests based on vibration of this type have proved satisfactory for determining critical frequencies, modes of vibration, and other data necessary for planning protective steps against the effects of undue vibration. Vibration, by causing loosening of parts or relative motion between parts in the specimen, can produce objectionable operating characteristics, noise, wear, and physical distortion, and often results in fatigue and failure of mechanical parts.

1100.3.7.3 Sand and dust test. The dust test is used during the development, test, and evaluation of equipment to ascertain their ability to resist the effects of a dry dust (fine sand) laden atmosphere. This test simulates the effect of sharp-edged dust (fine sand) particles, up to 150 microns in size, which may penetrate into cracks, crevices, bearings, and joints, and cause a variety of damage such a fouling moving parts, making relays inoperative, forming electrically conductive bridges with resulting "shorts," and acting as a nucleus for the collection of water vapor, and hence a source of possible corrosion and malfunction of equipment. This test is applicable to all mechanical, electrical, electronic, electrochemical, and electromechanical devices for which exposure to the effects of a dry dust (fine sand) laden atmosphere is anticipated.

1100.3.7.4 Life test. This test is conducted for the purpose of determining the effects on electrical and mechanical characteristics of a part, resulting from exposure of the part to an elevated ambient temperature for a specified length of time, while the part is performing its operational function. This test method is not intended for testing parts whose life is expressed in the number of operations. Evidence of deterioration resulting from this test can at times be determined by visual examination; however, the effects may be more readily ascertained by measurements or tests prior to, during, or after exposure. Surge current, total resistance, dielectric strength, insulation resistance, and capacitance are types of measurements that would show the deleterious effects due to exposure to elevated ambient temperatures.

1100.3.7.5 Thermal shock (temperature) test. This test is conducted for the purpose of determining the resistance of a part to exposures at extremes of high and low temperatures, and to the shock of alternate exposures to these extremes, such as would be experienced when equipment or parts are transferred to and from heated shelters in arctic areas. These conditions may also be encountered in equipment operated noncontinuously in low-temperature areas or during transportation. Although it is preferred that the specimen reach thermal stability at the temperature of the test chamber during the exposure specified, in the interest of saving test time, parts may be tested at a minimum exposure duration specified, which will not ensure thermal stability, but only an approach thereto. Permanent changes in operating characteristics and physical damage produced during thermal shock

IN-PROCESS AND ACCEPTANCE TESTING
OF CABLE ASSEMBLIES

results principally from variations in dimensions and other physical properties. Effects of thermal shock include cracking and delamination of finishes, cracking and crazing of embedding and encapsulating compounds, opening of thermal seals and case seams, leakage of filling materials, rupturing or cracking of hermetic seals and vacuum glass to metal seals, and changes in electrical characteristics due to mechanical displacement or rupture of conductors or insulating materials.

1100.3.7.6 Moisture resistance test. The moisture resistance test is performed for the purpose of evaluating, in an accelerated manner, the resistance of component parts and constituent materials to the deteriorative effects of the high humidity and heat conditions typical of tropical environments. Most tropical degradation results directly or indirectly from absorption of moisture vapor and films by vulnerable insulating materials, and from surface wetting of metals and insulation. These phenomena produce many types of deterioration, including corrosion of metals, physical distortion and decomposition of organic materials, leaching out and spending of constituents of materials, and detrimental changes in electrical properties. This test differs from the steady state humidity test and derives its added effectiveness in its employment of temperature cycling, which provides alternate periods of condensation and drying essential to the development of the corrosion processes and, in addition, produces a "breathing" action of moisture into partially sealed containers. Increased effectiveness is also obtained by use of a higher temperature, which intensifies the effect of humidity. The test includes low temperature and vibration subcycles that act as accelerants to reveal otherwise undiscernible evidences of deterioration, since stresses caused by freezing moisture and accentuated by vibration tend to widen cracks and fissures. As a result, the deterioration can be detected by the measurement of electrical characteristics (including such tests as DWV and insulation resistance) or by performance of a test for sealing. Provision is made for the application of a polarizing voltage across insulation to investigate the possibility of electrolysis, which can promote eventual dielectric breakdown. This test also provides for electrical loading of certain components, if desired, in order to determine the resistance of current-carrying components, especially fine wires and contacts, to electrochemical corrosion. Results obtained with this test are reproducible and have been confirmed by investigations of field failures. This test has proved reliable for indicating those parts which are unsuited for tropical field use.

1100.3.7.7 Salt spray test. The salt spray test, in which specimens are subjected to a fine mist of salt solution, has several useful purposes when utilized with full recognition of its deficiencies and limitations. Originally proposed as an accelerated laboratory corrosion test simulating the effects of seacoast atmospheres on metals, with or without protective coatings, this test has been erroneously considered by many as an all-purpose accelerated corrosion test, which if "withstood successfully" will guarantee that metals or protective coatings will prove satisfactory under any corrosive condition. Experience has since shown that there is seldom a direct relationship between resistance to salt spray corrosion and resistance to corrosion in other media, even in so-called "marine" atmospheres and ocean

MIL-STD-339(AT)
SECTION 1100
IN-PROCESS AND ACCEPTANCE TESTING
OF CABLE ASSEMBLIES

water. However, some idea of the relative service life and behavior of different samples of the same (or closely related) metals or of protective coating-base metal combinations in marine and exposed seacoast locations can be gained by means of the salt spray tests, provided accumulated data from correlated field service tests and laboratory salt spray tests show that such a relationship does exist, as in the case of aluminum alloys. (Such correlation tests are also necessary to show the degree of acceleration, if any, produced by the laboratory test.) The salt spray test is generally considered unreliable for comparing the general corrosion resistance of different kinds of metals or coating-metal combinations, or for predicting their comparative service life. The salt spray test has received its widest acceptance as a test for evaluating the uniformity (specifically, thickness and degree of porosity) of protective coatings, metallic and nonmetallic, and has served this purpose with varying amounts of success. In this connection, the test is useful for evaluating different lots of the same product, once some standard level of performance has been established. The salt spray test is especially helpful as a screening test for revealing particularly inferior coatings. When used to check the porosity of metallic coatings, the test is more dependable when applied to coatings which are cathodic rather than anodic toward the basic metal. This test can also be used to detect the presence of free iron contaminating the surface of another metal, by inspection of the corrosion products.

1100.3.7.8 Humidity test. This test is performed to evaluate the properties of materials used in components as they are influenced by the absorption and diffusion of moisture and moisture vapor. This is an accelerated environmental test, accomplished by the continuous exposure of the specimen to high relative humidity at an elevated temperature. These conditions impose a vapor pressure on the material under test which constitutes the force behind the moisture migration and penetration. Hygroscopic materials are sensitive to moisture, and deteriorate rapidly under humid conditions. Absorption of moisture by many materials results in swelling, which destroys their functional utility and causes loss of physical strength and changes in other important mechanical properties. Insulating materials which absorb moisture may suffer degradation of their electrical properties. This method, while not necessarily intended as a simulated tropical test, is of use in determining moisture absorption of insulating materials.

1100.3.7.9 Altitude test. The purpose of this test is to demonstrate the ability of connector-to-wire and interface area seals of a mated connector assembly to perform satisfactorily during and subsequent to simulated rapid descents from high altitude with attendant moisture condensation.

1100.3.7.10 Fluid immersion test. This test is performed to determine whether cable assemblies and their components can withstand immersion in various fluids, i.e., hydraulic fluid and lubricating oil, for specified periods of time without mechanical or electrical failure. Swelling of elastomeric parts and penetration of seals are the primary modes of failure examined in this test.

IN-PROCESS AND ACCEPTANCE TESTING
OF CABLE ASSEMBLIES

1100.3.7.11 Water immersion test. This test is performed to determine the effectiveness of the seal of component parts. The immersion of the part under evaluation into liquid at widely different temperatures subjects it to thermal and mechanical stresses which will readily detect a defective terminal assembly, or a partially closed seam or molded enclosure. Defects of these types can result from faulty construction or from mechanical damage such as might be produced during physical or environmental tests. The immersion test is generally performed immediately following such tests because it will tend to aggravate any incipient defects in seals, seams, and bushings which might otherwise escape notice. This test is essentially a laboratory test condition, and the procedure is intended only as a measurement of the effectiveness of the seal following this test. The choice of fresh or salt water as a test liquid is dependent on the nature of the component part under test. When electrical measurements are made after immersion cycling to obtain evidence of leakage through seals, the use of a salt solution instead of fresh water will facilitate detection of moisture penetration. This test provides a simple and ready means of detection of the migration of liquids. Effects noted can include lowered insulation resistance, corrosion of internal parts, and appearance of salt crystals. The test described is not intended as a thermal shock or corrosion test, although it may incidentally reveal inadequacies in these respects.

1100.3.7.12 Nuclear, Biological, and Chemical (NBC) testing. This group or any portion of this group of tests may be required on some cable assemblies. The procurement document should specify what, if any, type of testing is required.

1100.3.7.12.1 Nuclear test. The cable assembly may be tested for EMI (Electro Magnetic Interference) and EMP (Electro Magnetic Pulse) shielding. This test will check EM (Electro Magnetic) leakage from the cable at various frequencies. These frequencies may be as low as 10 kHz and as high as 10 G.H. and up. Materials chosen should be as able to pass this test as specified by the procurement document.

1100.3.7.12.2 Biological test. In this test the cable assemblies are exposed to biological attacks that the cable may come in contact with during usage. The cables, component, and materials should be able to withstand the microbes specified in test requirements on the procurement documents. The cable assembly also has to withstand the chemicals and procedure used for decontamination. After test is complete and parts have been decontaminated, specific tests may be required. These tests may include dielectric strength, insulation resistance, or other tests which would be noted on the procurement document.

1100.3.7.12.3 Chemical test. This test exposes cables to various types of chemicals that they could contact during usage. The procurement document defines the exact chemicals that should be used in this test. The cable assembly and all of its components should be made of materials that are able to withstand the chemicals used in the test along with whatever

MIL-STD-339(AT)
SECTION 1100
IN-PROCESS AND ACCEPTANCE TESTING
OF CABLE ASSEMBLIES

decontaminate that is used. After the chemical test is complete and the assembly has been decontaminated, specific tests are made on the cable assembly to assure the cable has not been functionally damaged. The tests required may include dielectric strength, insulation resistance, conductor continuity, or some other test that will be noted on the procurement document.

1100.4 QUALITY ASSURANCE PROVISIONS

1100.4.1 Inspections. Inspections shall be performed in accordance with the applicable military specification or drawing.

1100.5 PACKAGING

1100.5.1 Preservation, packaging, packing, and marking. Preservation, packaging, packing, and marking for the desired level shall be in accordance with the applicable drawing or packaging requirements specified by the contracting authority.

1100.6 NOTES

1100.6.1 Definitions. See section 600.

MIL-STD-339(AT)
SECTION 1200
INSTALLATION OF CABLE ASSEMBLIES
AND WIRING DEVICES

1200.1 SCOPE

1200.1.1 Scope. This section covers the installation of cable assemblies and wiring devices in combat and tactical vehicles.

1200.2 APPLICABLE DOCUMENTS

1200.2.1 Government documents.

1200.2.1.1 Specifications and standards. The following specifications and standards form a part of this standard to the extent specified herein. Unless otherwise specified, the issues of these documents shall be those listed in the issue of the Department of Defense Index of Specifications and Standards (DODISS) and supplement thereto, cited in the solicitation.

SPECIFICATIONS
FEDERAL

HH-I-595 - Insulation Tape, Electrical,
Pressure-Sensitive Adhesive, Plastic.

MILITARY

MIL-E-6051 - Electromagnetic Compatibility Requirements,
Systems.
MIL-T-7928 - Terminals, Lug: Splices, Conductors:
Crimp Style, Copper, General Specification
for.
MIL-S-23190 - Straps, Clamps, and Mounting Hardware,
Plastic and Metal for Cable Harness Tying
and Support.
MIL-T-43435 - Tape, Lacing and Tying.
MIL-T-81714 - Terminal Junction System, General
Specification for.

STANDARDS
MILITARY

MS18029 - Cover Assembly, Electrical, for MS27212
Terminal Board Assembly.
MS21266 - Grommet, Plastic, Edging.
MS21919 - Clamp, Loop Type, Cushioned, Support.
MS25171 - Nipple, Electrical Terminal.
MS25281 - Clamp, Loop, Plastic, Wire Support.
MS27212 - Terminal Board Assembly, Molded-In Stud,
Electric.
MS35489 - Grommets, Synthetic and Silicone Rubber,
Hot-Oil and Coolant Resistant.
MS35490 - Grommet, Rubber-Split, General Purpose.
MS90387 - Tool, Hand, Adjustable for Plastic Tiedown
Straps.

SECTION 1200

INSTALLATION OF CABLE ASSEMBLIES
AND WIRING DEVICES

(Copies of specifications, standards, handbooks, drawings, publications, and other Government documents required by the contractors in connection with specific acquisition functions should be obtained from the contracting activity or as directed by the contracting activity.)

1200.2.3 Order of precedence. In the event of a conflict between the text of this standard and the references cited herein, the text of this standard shall take precedence.

1200.3 REQUIREMENTS

1200.3.1 Introduction. Cable assemblies and wiring harnesses shall be fabricated and installed so as to achieve the following:

- a. Maximum reliability.
- b. Minimum interference and coupling between systems.
- c. Accessibility for inspection and maintenance.
- d. Prevention of damage.

The ease of maintenance, removal, and complete replacement of cable assemblies and wiring harnesses shall be given consideration in the wiring design.

1200.3.2 Arrangement of wiring. Wiring shall be arranged in groups and bundles to facilitate installation and maintenance. Wiring which serves individual systems may be grouped by spot ties or other approved means. Groups may be bundled provided the spot ties are not removed.

1200.3.2.1 Bundle and group size. As a design objective, bundles and groups within clamps shall be no more than 2 inches in diameter. High density wiring harnesses are exempt from this requirement. Wiring to high density connectors may be run as a single group, provided all of the wiring in the group is pertinent to a single item, equipment, or system.

1200.3.3 High-density wiring harness size. The number of wires in high-density wiring harnesses shall be limited only by efficient and good design. The use of wire sizes larger than #16 AWG is discouraged unless there are also smaller wires in the same wiring harness.

1200.3.4 Routing. Wiring shall be routed to assure reliability and to offer protection from the following hazards:

- a. Chafing.
- b. Use as handholds, or as support for personal equipment.
- c. Damage by personnel moving within the vehicle.
- d. Damage by stowage or shifting of cargo.
- e. Damage by battery or acid fumes and fluids.
- f. Combat damage (to the maximum extent practicable).
- g. Damage by moving parts.

MIL-STD-339(AT)
SECTION 1200
INSTALLATION OF CABLE ASSEMBLIES
AND WIRING DEVICES

1200.3.5 Slack in wiring. Slack requirements shall be met on every production vehicle as well as experimental models. In production wiring harness fabrication, provisions shall be incorporated into the wiring harness design and fabrication process to ensure that the installed wiring harness meets these requirements without the need for straining, forcing, or modifying the wiring harness.

When wiring is terminated in a connector (excluding RF connectors), a minimum of 1 inch of slack for complete connector replacement shall be provided. This slack shall be between the connector and the second wiring support clamp. The 1-inch slack requirement shall be interpreted to mean, that with the connector unmated and the first wiring support clamp loosened, the wiring will permit the front end of the connector shell to extend 1 inch beyond the point normally required to properly mate the connector.

At each end of a wire terminated by a lug, a minimum length of slack equal to twice the barrel length of the lug shall be provided. For copper wire #2 AWG and larger, the minimum length of slack shall be equal to one barrel length of the lug. The slack shall be in the vicinity of the lug and available for replacement of the lug by maintenance personnel.

1200.3.6 Protection and support. Wiring shall be supported to meet the following requirements:

- a. Prevent chafing.
- b. Secure wiring where routed through bulkheads and structure members.
- c. Properly group, support, and route wiring in junction boxes, panels, and bundles.
- d. Prevent mechanical strain or work hardening that would tend to break the conductors and connectors.
- e. Prevent arcing or overheated wiring from causing damage to mechanical control cables, and associated moving equipment.
- f. Facilitate reassembly to equipment terminal boards.
- g. Prevent interference between wiring and other equipment.
- h. Provide support for wiring to prevent excessive movement in areas of high vibration.

1200.3.6.1 Primary support. Primary support of wiring shall be provided by MS21919 cushion clamps or MS25281 plastic clamps, spaced at intervals not greater than 24 inches. Open wiring contained in troughs, ducts, or conduits is exempt from this requirement. Rigid portions of wiring harnesses shall be supported by clamps spaced at intervals not greater than 42 inches. Clamps for wiring harnesses other than round shall be shaped to fit the contour of the wiring harness and shall provide a snug fit. Plastic clamps shall not be used to support rigid portions of wiring harnesses. Plastic cable straps shall not be used as primary supporting devices unless specifically approved by the procuring activity and then they shall be subject to the restrictions invoked on plastic clamps. The primary support of wiring shall not be attached to adjacent wiring.

MIL-STD-339(AT)
SECTION 1200
INSTALLATION OF CABLE ASSEMBLIES
AND WIRING DEVICES

1200.3.6.1.1 Plastic clamps. Plastic cable clamps may be used on horizontal wiring runs provided every fourth clamp is a rubber cushion type. The use of plastic cable clamps on other than horizontal wiring runs shall be avoided unless the installation is such that slack cannot accumulate between clamping points, and then every fourth clamp is a rubber cushion type.

1200.3.6.1.2 Clamp size. Primary supporting devices shall be of a size which will hold the wiring in place without damaging the insulation. Tape which is not moisture absorbent may be wrapped around groups in order to provide a proper fit.

1200.3.6.1.3 Support at connectors. Wiring terminating in plugs shall be supported to dress the wiring in the direction of the run. This may be accomplished by adapters, clamps, potting, wire guides, or other means acceptable to the procuring activity.

1200.3.6.2 Secondary support. Secondary support of wiring (support between primary supports) shall be provided by devices selected from the following:

- a. Tying tape in accordance with MIL-T-43435, type I, finish B or type II, finish C.
- b. Plastic cable straps in accordance with MIL-S-23190, installed with tools in accordance with MS90387.
- c. Insulation tape in accordance with HH-I-595.

1200.3.7 Radius of bend. The minimum radius of bend for wire or cable shall be 10 times the outside diameter of the wire or cable, except that at terminal strips where the wire is suitably supported, the radius may be 3 times the diameter of the wire. Where it is impracticable to install these cables within the radius requirements, the bend shall be enclosed in insulating tubing. For coaxial cables, the minimum radius of bend shall not unduly affect the characteristics of the cable. The minimum radius of bend shall be not less than six times the outside diameter of the coaxial cable. For high-strength cables or bundles, the radius of bend shall not cause the outer wires to exceed 5-percent elongation. The minimum radius of bend for high-density wiring harnesses shall be six times the outside diameter of the wiring harness except on portions other than round where the bend shall be six times the cross-sectional dimension on the plane of the bend. These minimums shall be maintained during handling and storage prior to and during installation.

1200.3.8 Wiring near moving parts. Wiring attached to assemblies where relative movement occurs (such as at hinges and rotating pieces: control wheels and columns) shall be installed or protected in such manner as to prevent deterioration of the wiring by the relative movement of the assembly parts. This deterioration includes abrasion of one wire or cable upon

another and excess twisting and bending. Bundles shall be installed to twist instead of bend across hinges. Cables in the vicinity of Line Replaceable Units (LRU's) and Weapon Replaceable Assemblies (WRA's) shall be protected against damage by flexing, pulling, abrasion, and other effects of frequent removal and replacement of equipment.

1200.3.9 Anti-chafing provisions. Chafing shall be prevented by routing and clamping bundles to prevent contact with edges of equipment and structure. Where physical separation of at least 3/8 inch cannot be maintained, the edges shall be covered with suitable protection strips such as grommets. Grommets and protection strips shall be securely fastened in place with bonding or other suitable means. Shielded cables shall have an external insulating cover.

1200.3.10 Insulation compatibility with sealing and servicing. Wiring terminating in devices where the wiring must be sealed to provide an environment-proof joint shall have insulation compatible with the sealing feature of the device. Elastomer grommets are generally qualified to seal on wires having smooth extruded insulations. Only one wire per grommet hole is permitted. Sealing or wrapped, braided, striped, or other than smooth circular insulations shall be specifically tested for compatibility and shall be subject to procuring activity approval, unless compatibility has been demonstrated in the qualification of the terminating device. The wiring shall be installed so that transverse loads will not destroy the integrity of the sealing feature of the grommet.

1200.3.11 Wire diameter. The finished wire outside diameter shall be within the limits specified in the connector specification and shall not exceed the capability of contact servicing tools to insert and release contacts.

1200.3.12 Potting seal on wire. Where potting is used, the sealing compound shall bond to the wire insulation.

1200.3.13 Insulation degradation. Wiring shall be handled, stripped, and installed so as not to distort, roughen, or damage the insulation on which sealing is to be effected. Methods of marking and identification shall be applied so as not to provide a track for moisture entry. The impression left on the insulation of shielded and twisted wires can also cause unacceptable degradation of the insulation in relation to the elastomer seal. Caution shall be used to avoid this condition.

1200.3.14 Wiring mockup. When specified in the contract, the contractor shall conduct a wiring mockup for inspection by the procuring activity, prior to delivery of the first vehicle and in time to permit needed changes. On this mockup, the contractor shall demonstrate typical wiring installations and specific wiring practices for which deviations are required. This mockup may be conducted on a production vehicle.

MIL-STD-339(AT)
SECTION 1200
INSTALLATION OF CABLE ASSEMBLIES
AND WIRING DEVICES

1200.3.15 Inspection of first vehicle. The wiring installation of the first complete vehicle shall be inspected at the contractor's plant by the contractor under supervision of the procuring activity to determine conformance with the requirements of this standard, and shall be subject to approval by the procuring activity.

1200.3.16 Changes in wiring. Vehicles in which changes have been made in the wiring shall be inspected at the contractor's plant by the contractor under the supervision of the procuring activity to determine conformance with the requirements of this standard.

1200.3.17 Individual tests. Functional checks shall be conducted by the contractor on each vehicle to ensure proper continuity of all electrical and electronic circuits, and proper operation of all electrical and electronic equipment.

1200.3.18 Assembly. Lug-terminated wire shall be installed so as to reduce human error in assembly to adjacent terminals. Control of wire length from tie-down points, fanning strips, or different size stud holes are preferred to dependence on code identification.

1200.3.18.1 Sensitive circuits. Sensitive circuits such as low-power-level signal circuits shall be kept separate from other circuits at junctions. This shall be accomplished by using separate connectors for the sensitive circuits and by having at least one grounded terminal stud between sensitive circuits and other circuits on a common terminal board.

1200.3.18.2 Terminals. Wire terminals shall be used to connect wiring to terminal block studs or equipment terminal studs. Not more than four terminals shall be connected to any one stud. When the terminals attached to a stud vary in diameter, the greatest diameter shall be placed on the bottom and smallest diameter on top. Terminals shall be selected with a stud hole diameter which matches the diameter of the stud. Tightening terminal connections shall not deform the terminals or the studs. Terminals shall be so positioned that bending of the terminal is not required to remove the fastening screw or nut, and movement of the terminal will tend to tighten the connection.

1200.3.18.2.1 Copper terminals. Solderless, crimp-style, copper wire terminals shall be used except where otherwise specifically approved by the procuring activity. Terminals shall be insulated or uninsulated copper terminals conforming to MIL-T-7928.

1200.3.18.3 Terminal boards. MS27212 terminal boards or MIL-T-81714 terminal junction modules and tracks shall be used for junctions of wiring requiring infrequent disconnection or joining of two or more wires and cables to a common point. Unused grommet holes shall be filled with a plastic sealing plug. MS18029 terminal board covers shall be used with MS27212 terminal boards.

1200.3.18.4 Grommets. Grommets shall be in accordance with MS21266, MS35489, or MS35490. MS21266 grommets shall be permanently bonded in place and shall prevent the wires from contacting the sides of the holes.

1200.3.18.4.1 Split grommets. The remaining opening in split grommets shall be not wider than 1/16 inch. The splits shall be diagonal and placed in the cutouts in such a manner that the wire pressure will be on the opposite side from the split.

1200.3.18.5 Hoods and nipples. MS25171 terminal nipples or suitable insulating hoods may be used to provide overall insulation and protection on terminal lugs and studs when approved by the procuring activity.

1200.3.18.6 Insulation tape. Insulation tape shall be used primarily as filler under clamps. Plastic tape (nonadhesive) may be used as a wrap around wiring where additional protection is necessary, such as in wheel wells. Tape (adhesive or nonadhesive) when used as protective wrap shall have the ends tied or otherwise suitably secured to prevent unwinding.

1200.3.18.7 Electromagnetic compatibility. Wiring, including RF and antenna cables, shall be routed so as to accomplish elimination of electromagnetic interference in accordance with MIL-E-6051.

1200.4 QUALITY ASSURANCE PROVISIONS

1200.4.1 Inspections. Inspections shall be performed in accordance with the applicable military specification or drawing.

1200.5 PACKAGING

1200.5.1 Preservation, packaging, packing, and marking. Preservation, packaging, packing, and marking for the desired level shall be in accordance with the applicable drawing or packaging requirements specified by the contracting authority.

1200.6 NOTES

1200.6.1 Definitions. See section 600.

MIL-STD-339(AT)

6. NOTES

6.1 Intended use. This standard is intended to be used for the design and installation of a complete cable system in combat and tactical vehicles.

6.2 Subject term (key word) listing.

Cable
Cable assembly
Wire
Wiring device
Wiring harness

6.3 Supersession data. This standard supersedes Drawing 8722729, dated 16 May 1960 (see section 700); AM General Corporation specification 150, revision C, dated 14 March 1984 (see section 800); and General Electric Company Ordnance Systems specification 12292534, revision C, dated 28 June 1983 (see section 900).

MIL-STD-339(AT)

INDEX

	<u>Paragraph</u>	<u>Page</u>
Acceptance testing	1100.3.4	119
Adapter method	900.3.3.9.4	112
Additional useful information	200.3.7	27
Adjacent locations	400.3.8	39
Altitude test	1100.3.7.9	124
Ambient temperature	100.3.3.7	21
Anti-chafing provisions	1200.3.9	131
Arrangement	900.3.3.7	107
Arrangement of wiring	1200.3.2	128
Assembly	1200.3.18	132
Bend test	1100.3.6.5	121
Biological test	1100.3.7.12.2	125
Binding	700.3.1	94
Boots	500.3.2	48
Braid	800.3.1.4	99
Braiding	800.3.2.7	100
Breakoffs	900.3.3.7.5	109
Bundle and group size	1200.3.2.1	128
Bundling techniques	900.3.3.7.1	107
Butyl rubber	300.3.3.2.4	32
Cable binders - separators	600.3.7	59
Cable selection	100.3.3.11	21
Cables	800.3.1.1	98
Calculation	600.3.9	60
Carriers (C)	200.3.6.1.3	25
Changes in wiring	1200.3.16	132
Characters	1000.3.3.1.3	116
Chemical test	1100.3.7.12.3	125
Chloroprene rubber (Neoprene)	300.3.3.2.2	30
Chlorosulfonated polyethylene (Hypalon)	300.3.3.3	32
Circuit identification	800.3.2.10	101
Clamp size	1200.3.6.1.2	130
Coaxial cables	100.3.3.2	18
Coaxial connectors	400.3.6	39
Cold-bend test	1100.3.6.1	120
Color	1000.3.3.1.2	116
Color code and related numbers	600.3.6.2	59
Color coding	600.3.6	58
Commercial utility parts	4.3.2	4
Commonality	4.3.4	5
Component selection	100.3.2	9
Conductor/cable size	800.3.1.1.1	98
Conductor marker location	900.3.2.4.3	105
Conflicting requirements	4.2	4
Connector installation	400.3.7	39
Connectors	400.3.3	37
Construction	800.3.2	99
Contacts	400.3.9	40

MIL-STD-339(AT)

INDEX - Continued.

	<u>Paragraph</u>	<u>Page</u>
Continuity	700.3.9	96
	1100.3.5.1	119
Contractors' specifications	4.3.3	4
Convolute tubing	300.3.4	32
Convolute tubing cable assembly	600.3.13	71
Copper terminals	1200.3.18.2.1	132
Corona prevention	100.3.3.5	18
Crimp technique	400.3.12	42
Crimp tools	400.3.12.1	43
Crimper	900.3.1.3	104
Crimping	700.3.2	95
	800.3.2.2	99
	900.3.3.3	105
Current-carrying capacity	100.3.3.6	19
D.C. and low frequency	200.3.3.1	24
Definitions	400.6.1	43
	500.6.1	49
	600.6.1	82
Deviations	4.1	4
Dielectric Withstanding Voltage (DWV)	1100.3.5.2	119
Dimensional tolerances	900.3.3.6	107
Dummy receptacles	500.3.7	49
Dust caps	500.3.4	48
Electrical testing	1100.3.5	119
Electromagnetic compatability	1200.3.18.7	133
Electrostatic shielding	200.3.4	25
Elevated temperature degradation	100.3.3.1	9
End connections	900.3.2.5	105
Environmental testing	1100.3.7	121
Fillers	600.3.10	63
Finishing tie	900.3.3.7.4	109
Fireproof and firewall connectors	400.3.5	39
Fittings	300.3.4.2	33
Floating shields	600.3.14.2	76
Fluid immersion test	1100.3.7.10	124
Government Furnished Equipment (GFE)	4.3.5	5
Grommets	1200.3.18.4	133
Heat-shrinkable insulation sleeving	800.3.1.3	99
Heat-shrinkable sleeving and breakouts	900.3.2.1	104
Heat-shrinkable tubing	300.3.3.4	32
High-density wiring harness size	1200.3.3	128
High-density wiring	100.3.3.3	18
High-impact shock test	1100.3.7.1	121
Hoods and nipples	1200.3.18.5	133
Humidity test	1100.3.7.8	124
Hybrid cable assemblies	600.3.12	68
Identification of circuit numbers	700.3.8	96
Impact test	1100.3.6.2	120

MIL-STD-339(AT)

INDEX - Continued.

	<u>Paragraph</u>	<u>Page</u>
Impression marking	1000.3.3.2	116
Individual tests	1200.3.17	132
Information	1000.3.2	115
Ink	1000.3.3.1.1	116
Ink marking	1000.3.3.1	116
Inner/outer shield terminations	600.3.14.1	75
Inspection of first vehicle	1200.3.15	132
Insulation compatability with sealing and servicing	100.3.3.4 1200.3.10	18 131
Insulation degradation	100.3.3.4.3 1200.3.13	18 131
Insulation resistance	700.3.10 1100.3.5.3	96 120
Insulation tape	1200.3.18.6	133
Lacing	700.3.7	96
Lay	600.3.5	58
Lay pattern development	600.3.8	60
Lettering style, size, and color	900.3.2.4.2	105
Life test	1100.3.7.4	122
Lockstitches	900.3.3.7.3	108
Loom	800.3.1.6 800.3.2.9	99 101
Magnetic shielding	200.3.3	24
Markers, assembly and wire	900.3.2.3	104
Marking	900.3.2.4 900.3.3.5	104 107
Materials	800.3.1 900.3.2	98 104
Methods	1000.3.3	116
Modification	4.3.6	5
Moistureproof connectors	400.3.4	37
Moisture resistance test	1100.3.7.6	123
Molded cable assemblies	600.3.4	56
Molding compound selection	600.3.11	63
Natural rubber (Polyisoprene)	300.3.3.2.1	30
Normal method	900.3.3.9.3	110
Nuclear, Biological & Chemical (NBC) testing	1100.3.7.12	125
Nuclear test	1100.3.7.12.1	125
Number of ends per carrier (N)	200.3.6.1.1	26
Offset method	900.3.3.9.5	113
1 kHz to 1 MHz	200.3.3.3	25
Percent coverage	200.3.6.1	25
Permanency	900.3.2.4.1	104
Physical testing (mechanical)	1100.3.6	120
Picks per inch (P)	200.3.6.1.2	26
Pigttailed braid grounding	600.3.14.4	79
Plastic clamps	1200.3.6.1.1	130

MIL-STD-339(AT)

INDEX - Continued.

	<u>Paragraph</u>	<u>Page</u>
Polyurethanes	300.3.3.1	30
Potting	700.3.6	95
Potting seal on wire	100.3.3.4.2	18
	1200.3.12	131
Preliminary design	100.3.1	8
Primary support	1200.3.6.1	129
Protection and support	1200.3.6	129
Protective covers	500.3.5	48
Provision plugs	500.3.6	49
Qualification testing	1100.3.3	119
Radio frequencies	200.3.3.2	24
Radius of bend	1200.3.7	130
Requests for approval of nonstandard parts	4.3.1	4
Required procedures and operations	900.3.3	105
Resilient extruded tubing	300.3.3	30
Responsibility for testing	1100.3.2	119
Round wire shields	200.3.5.1	25
Routing	1200.3.4	128
Rubbers	300.3.3.2	30
Salt spray test	1100.3.7.7	123
Sand and dust test	1100.3.7.3	122
Secondary support	1200.3.6.2	130
Selection	400.3.2	37
Selection of parts and materials	4.3	4
Sensitive circuits	1200.3.18.1	132
Service life	4.4	5
Shield coverage	200.3.6	25
Shield effectiveness	200.3.2	24
Shield terminations	600.3.14	74
	900.3.3.8	110
Shield types	200.3.5	25
Silicone rubber	300.3.3.2.5	32
Silver-plated conductors	100.3.3.1.2	9
Size	300.3.4.1	33
Slack in wiring	1200.3.5	129
Solder	900.3.2.2	104
Solder equipment	900.3.1.2	103
Solder sleeve terminations	600.3.14.3	77
Solder-type contacts	400.3.11	42
Solderability	100.3.3.1.3	9
Soldering	700.3.3	95
	800.3.2.3	99
	900.3.3.2	105
Spacing	900.3.3.7.6	109
Spare contacts	400.3.10	40
Spare grommet holes	700.3.5	95
	800.3.2.5	100

MIL-STD-339(AT)

INDEX - Continued.

	<u>Paragraph</u>	<u>Page</u>
Splicing	700.3.4	95
	800.3.2.4	100
Split grommets	1200.3.18.4.1	133
Starting tie and spot tie	900.3.3.7.2	107
Strain relief	500.3.3	48
Striping method	600.3.6.1	59
Stripping	800.3.2.6	100
	900.3.3.1	105
Styrene-butadiene rubbers	300.3.3.2.3	30
Support at connectors	1200.3.6.1.3	130
Tape	300.3.2	29
	800.3.1.5	99
Taping	800.3.2.8	101
Terminal boards	1000.3.18.3	132
Terminals	1200.3.18.2	132
Terminals and connectors	800.3.1.2	98
Terminology, cable	600.3.2	52
Thermal shock (temperature) test	1100.3.7.5	122
Tin-plated conductors	100.3.3.1.1	9
Tolerances for cable assemblies	800.3.2.1	99
Torque test	1100.3.6.3	121
Twist test	1100.3.6.4	121
Two-conductor crimp termination	900.3.3.3.1	105
Two-conductor termination	900.3.3.9	110
Useful formulas for cables	600.3.15	80
Variations	900.3.3.9.1	110
Vibration test	1100.3.7.2	122
Voltage drop	100.3.3.9	21
Water immersion test	1100.3.7.11	125
Wire and cable identification	100.3.3.10	21
Wire cutter	900.3.1.4	104
Wire cutting	900.3.3.4	107
Wire diameter	100.3.3.4.1	18
	1200.3.11	131
Wire marking	900.3.1.5	104
Wire preparation	900.3.3.9.2	110
Wire stripper	900.3.1.1	103
Wires terminated in connectors	100.3.3.8	21
Wiring harness identification	800.3.2.11	101
Wiring harnesses	600.3.3	53
Wiring mockup	1200.3.14	131
Wiring near moving parts	1200.3.8	130
Wiring selection	100.3.3	9

MIL-STD-339(AT)

Custodian:
Army - AT

Preparing activity:
Army - AT

(Project 6150-A210)

INSTRUCTIONS: In a continuing effort to make our standardization documents better, the DoD provides this form for use in submitting comments and suggestions for improvements. All users of military standardization documents are invited to provide suggestions. This form may be detached, folded along the lines indicated, taped along the loose edge (*DO NOT STAPLE*), and mailed. In block 5, be as specific as possible about particular problem areas such as wording which required interpretation, was too rigid, restrictive, loose, ambiguous, or was incompatible, and give proposed wording changes which would alleviate the problems. Enter in block 6 any remarks not related to a specific paragraph of the document. If block 7 is filled out, an acknowledgement will be mailed to you within 30 days to let you know that your comments were received and are being considered.

NOTE: This form may not be used to request copies of documents, nor to request waivers, deviations, or clarification of specification requirements on current contracts. Comments submitted on this form do not constitute or imply authorization to waive any portion of the referenced document(s) or to amend contractual requirements.

(Fold along this line)

(Fold along this line)

DEPARTMENT OF THE ARMY



NO POSTAGE
NECESSARY
IF MAILED
IN THE
UNITED STATES

OFFICIAL BUSINESS
PENALTY FOR PRIVATE USE \$300

BUSINESS REPLY MAIL
FIRST CLASS PERMIT NO. 12062 WASHINGTON D. C.

POSTAGE WILL BE PAID BY THE DEPARTMENT OF THE ARMY

Commander
US Army Tank-Automotive Command
ATTN: AMSTA-GDS
Warren, MI 48397-5000

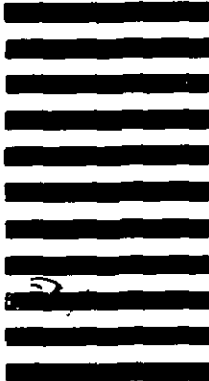

STANDARDIZATION DOCUMENT IMPROVEMENT PROPOSAL

(See Instructions - Reverse Side)

1. DOCUMENT NUMBER

2. DOCUMENT TITLE

3a. NAME OF SUBMITTING ORGANIZATION

4. TYPE OF ORGANIZATION (Mark one)

 VENDOR USER MANUFACTURER OTHER (Specify): _____

b. ADDRESS (Street, City, State, ZIP Code)

5. PROBLEM AREAS

a. Paragraph Number and Wording:

b. Recommended Wording:

c. Reason/Rationale for Recommendation:

6. REMARKS

7a. NAME OF SUBMITTER (Last, First, MI) - Optional

b. WORK TELEPHONE NUMBER (Include Area Code) - Optional

c. MAILING ADDRESS (Street, City, State, ZIP Code) - Optional

8. DATE OF SUBMISSION (YYMMDD)