

**NOTICE OF
 CHANGE**

INCH-POUND

**MIL-STD-348A
 NOTICE 1
 12 January 1990**

MILITARY STANDARD

RADIO FREQUENCY CONNECTOR INTERFACES FOR

**MIL-C-3643, MIL-C-3650, MIL-C-3655, MIL-C-25516, MIL-C-26637,
 MIL-C-39012, MIL-C-49142, MIL-A-55339, AND MIL-C-83517**

TO ALL HOLDERS OF MIL-STD-348A:

1. THE FOLLOWING PAGES OF MIL-STD-348A ARE NEW OR HAVE BEEN REVISED AND SUPERSEDE THE PAGES LISTED:

NEW PAGE	DATE	SUPERSEDED PAGE	DATE
iii	12 January 1990	iii	20 April 1988
iv	12 January 1990	iv	20 April 1988
v	12 January 1990		
5	12 January 1990	5	20 April 1988
6	12 January 1990	6	20 April 1988
101.1	12 January 1990	101.1	20 April 1988
101.2	12 January 1990	101.2	20 April 1988
102.1	12 January 1990	102.1	20 April 1988
102.2	20 April 1988	102.2	REPRINTED WITHOUT CHANGE
201.1	12 January 1990	201.1	20 April 1988
201.2	12 January 1990	201.2	20 April 1988
201.3	12 January 1990	201.3	20 April 1988
202.1	12 January 1990	202.1	20 April 1988
202.2	20 April 1988	202.2	REPRINTED WITHOUT CHANGE
202.3	12 January 1990	202.3	20 April 1988
SECTION 300	12 January 1990	SECTION 300	20 April 1988
301.1	20 April 1988	301.1	REPRINTED WITHOUT CHANGE
309.2	20 April 1988	309.2	REPRINTED WITHOUT CHANGE
310.1	12 January 1990	310.1	20 April 1988
310.2	12 January 1990	310.2	20 April 1988
310.3	20 April 1988	310.3	REPRINTED WITHOUT CHANGE
313.3	12 January 1990		
313.4	12 January 1990		
317.1	12 January 1990	317.1	20 April 1988
317.2	12 January 1990	317.2	20 April 1988
319.1	12 January 1990	319.1	20 April 1988
319.2	12 January 1990	319.2	20 April 1988
320.1	12 January 1990		
320.2	12 January 1990		

MIL-STD-348A
NOTICE 1

321.1	12 January 1990		
321.2	12 January 1990		
321.3	12 January 1990		
322.1	12 January 1990		
322.2	12 January 1990		
404.3	20 April 1988	404.3	REPRINTED WITHOUT CHANGE
405.1	19 January 1990	405.1	20 April 1988

2. RETAIN THIS NOTICE AND INSERT BEFORE TABLE OF CONTENTS.

3. Holders of MIL-STD-348A will verify that page changes and additions indicated above have been entered. This notice page will be retained as a check sheet. This issuance, together with appended pages, is a separate publication. Each notice is to be retained by stocking points until the military standard is completely revised or canceled.

CONCLUDING MATERIAL

Custodian:

Army - CR
Navy - EC
Air Force - 85

Preparing activity:

Army - CR

Agent:

DLA - ES

Review activities:

Army - AT, AV, MI
Navy - AS, SH
Air Force - 10, 11, 17, 99
DLA - ES

(Project 5935-3705)

User activities:

Navy - CG, MC
Air Force - 11

MIL-STD-348A
NOTICE 1
CONTENTS

		<u>Page</u>
1.	SCOPE - - - - -	1
1.1	Purpose - - - - -	1
1.2	Scope - - - - -	1
2.	REFERENCED DOCUMENTS- - - - -	2
2.1	Government documents - - - - -	2
2.1.1	Specification, and standard - - - - -	2
2.2	Order of precedence - - - - -	2
3.	DEFINITIONS - - - - -	3
3.1	Terms - - - - -	3
4.	GENERAL REQUIREMENTS- - - - -	4
5.	DETAILED REQUIREMENTS - - - - -	5
5.1	Gauge tests - - - - -	5
5.2	Marking - - - - -	5
5.3	Drawing notes - - - - -	5
5.4	Change effectivity - - - - -	5
5.5	Disposition of stock - - - - -	5
6.	NOTES - - - - -	6
6.1	Intended use - - - - -	6
6.2	Patent notice - - - - -	6
6.3	Subject term (key word) listing - - - - -	6
6.4	Changes from previous issue - - - - -	6

FIGURES

Figure	101-1. Interface, series TWTNC, coupling nut - - - - -	101.1
	101-2. Interface, series TWTNC, no coupling nut - - - - -	101.2
	102-1. Interface, series TWBNC, with coupling nut - - - - -	102.1
	102-2. Interface, series TWBNC, coupling nut - - - - -	102.2
	102-3. Interface, series TWBNC, without coupling nut - - - - -	102.3
	103-1. Interface, series TWSMC, with coupling nut- - - - -	103.1
	103-2. Interface, series TWSMC, without coupling nut - - - - -	103.2
	104-1. Interface, series TWSMB, with coupling mechanism- - - - -	104.1
	104-2. Interface, series TWSMB, without coupling mechanism - - - - -	104.2
	201-1. Interface, series TRB, pin contact- - - - -	201.1
	201-2. Interface, series TRB, socket contact - - - - -	201.2
	202-1. Interface, series TRT, pin contact- - - - -	202.1
	202-2. Interface, series TRT, socket contact - - - - -	202.2
	301-1. Interface, series BNC, pin contact- - - - -	301.1
	301-2. Interface, series BNC, socket contact - - - - -	301.2
	302-1. Interface, series C, pin contact- - - - -	302.1
	302-2. Interface, series C, socket contact - - - - -	302.2
	303-1. Interface, series MHV, pin contact- - - - -	303.1
	303-2. Interface, series MHV, socket contact - - - - -	303.2
	304-1. Interface, series N, pin contact- - - - -	304.1
	304-2. Interface, series N, socket contact - - - - -	304.2
	305-1. Interface, series QL, pin contact - - - - -	305.1
	305-2. Interface, series QL, socket contact- - - - -	305.2
	306-1. Interface, series QM, pin contact - - - - -	306.1

MIL-STD-348A
 NOTICE 1

CONTENTS - Continued

	<u>Page</u>
306-2. Interface, series QM, socket contact - - - - -	306.2
307-1. Interface, series QMC, pin contact - - - - -	307.1
307-2. Interface, series QMC, socket contact - - - - -	307.2
308-1. Interface, series QSC, pin contact - - - - -	308.1
308-2. Interface, series QSC, socket contact - - - - -	308.2
309-1. Interface, series SC, pin contact - - - - -	309.1
309-2. Interface, series SC, socket contact - - - - -	309.2
310-1. Interface, series SMA, pin contact - - - - -	310.1
310-2. Interface, series SMA, socket contact - - - - -	310.2
310-3. Interface, series SMA, no contact - - - - -	310.3
311-1. Interface, series SMB, pin contact - - - - -	311.1
311-2. Interface, series SMB, socket contact - - - - -	311.2
312-1. Interface, series SMC, pin contact - - - - -	312.1
312-2. Interface, series SMC, socket contact - - - - -	312.2
313-1. Interface, series TNC, pin contact - - - - -	313.1
313-2. Interface, series TNC, socket contact - - - - -	313.2
313-3. Interface, series TNC, pin contact, air interface - - -	313.3
313-4. Interface, series TNC, socket contact, air interface -	313.4
314-1. Interface, series SHV, pin contact - - - - -	314.1
314-2. Interface, series SHV, socket contact - - - - -	314.2
315-1. Interface, series LC, pin contact - - - - -	315.1
315-2. Interface, series LC, socket contact - - - - -	315.2
315-3. Interface, series LC, pin contact - - - - -	315.3
315-4. Interface, series LC, socket contact - - - - -	315.4
315-5. Interface, series LC, pin contact - - - - -	315.5
315-6. Interface, series LC, socket contact - - - - -	315.6
316-1. Interface, coaxial environment resistant - - - - -	316.1
316-2. Interface, coaxial environment resistant - - - - -	316.2
316-3. Interface, coaxial environment resistant - - - - -	316.3
316-4. Interface, coaxial environment resistant - - - - -	316.4
317-1. Interface, series HN, pin contact - - - - -	317.1
317-2. Interface, series HN, socket contact - - - - -	317.2
318-1. Interface, series LT, no contact - - - - -	318.1
318-2. Interface, series LT, socket contact - - - - -	318.2
319-1. Interface, series SSMA, pin contact - - - - -	319.1
319-2. Interface, series SSMA, socket contact - - - - -	319.2
320-1. Interface, series SSMB, pin contact - - - - -	320.1
320-2. Interface, series SSMB, socket contact - - - - -	320.2
321-1. Interface, series BMA, pin contact - - - - -	321.1
321-2. Interface, series BMA, socket contact - - - - -	321.2
321-3. Interface dimension table, series BMA - - - - -	321.3
322-1. Interface, series BMB, pin contact - - - - -	322.1
322-2. Interface, series BMB, socket contact - - - - -	322.2
401-1. Interface, test connector, series C, pin contact - - -	401.1
401-2. Interface, test connector, series C, socket contact - -	401.2
401-3. Interface, mated test connector, series C - - - - -	401.3
402-1. Interface, test connector, series N, pin contact - - -	402.1
402-2. Interface, test connector, series N, socket contact - -	402.2
402-3. Interface, mated test connector, series N - - - - -	402.3
403-1. Interface, test connector, series SC, pin contact - - -	403.1
403-2. Interface, test connector, series SC, socket contact - -	403.2
403-3. Interface, mated test connector, series SC - - - - -	403.3
404-1. Interface, test connector, series BNC, pin contact - - -	404.1
404-2. Interface, test connector, series BNC, socket contact - -	404.2
404-3. Interface, mated test connector, series BNC - - - - -	404.3
405-1. Interface, test connector, series SMA, pin contact - - -	405.1
405-2. Interface, test connector, series SMA, socket contact - -	405.2
405-3. Interface, mated test connector, series SMA - - - - -	405.3
406-1. Interface, test connector, series TNC, pin contact - - -	406.1

MIL-STD-348A
NOTICE 1

CONTENTS - Continued

	<u>Page</u>
406-2. Interface, test connector, series TNC, socket contact -	406.2
406-3. Interface, mated test connector, series TNC - - - - -	406.3
407-1. Interface, test connector, series SMB, pin contact- -	407.1
407-2. Interface, test connector, series SMB, socket contact -	407.2
407-3. Interface, mated test connector, series SMB - - - - -	407.3
408-1. Interface, test connector, series SMC, pin contact- -	408.1
408-2. Interface, test connector, series SMC, socket contact -	408.2
408-3. Interface, mated test connector, series SMC - - - - -	408.3
409-1. Interface, test connector, series QNC, pin contact- -	409.1
409-2. Interface, test connector, series QNC, socket contact -	409.2
409-3. Gap of mated standard test connector, series QNC- - -	409.3
410-1. Interface, test connector, series QSC, pin contact- -	410.1
410-2. Interface, test connector, series QSC, socket contact -	410.2
410-3. Gap of mated standard test connector, series QSC- - -	410.3

MIL-STD-348A
NOTICE 1

5. DETAILED REQUIREMENTS

5.1 Gauge tests. Applicable gauge tests shall be as specified in the associated connector specification sheet.

5.2 Marking. Not applicable.

5.3 Drawing notes. Unless otherwise specified, the following information is applicable to all figures of this military standard.

- a. Dimensions are in inches.
- b. Metric equivalents are given for general information only.
- c. All undimensioned, pictorial configurations are for reference purposes only.
- d. Applicable to section 400 only. The construction, material, and finish of the standard socket connector shall result in satisfactory electrical and mechanical performance and provide the following minimum life cycles when mated with the same series pin standard test connector.

<u>Series</u>	<u>Life cycles</u>
C, N, SC, TNC	10,000
BNC	5,000
SMA, SMB, SMC	2,000

- e. Applicable to section 400 only. Dimensions shown are for the standard test connector only.

5.4 Change effectivity. Unless otherwise specified in the interface figure, all changes from the preceding issue of MIL-STD-348 will become effective 12 months from the date of this standard notice.

5.5 Disposition of stock. Unless otherwise specified in the interface figure, qualified manufacturers and their selling agents or distributors may ship from stock connectors which were manufactured in accordance with the preceding issue of MIL-STD-348 for a period of 30 months from this date of this standard notice.

MIL-STD-348A
NOTICE 1

6. NOTES

(This section contains information of a general or explanatory nature which may be helpful, but is not mandatory.)

6.1 Intended use. This standard is intended for use by all manufacturers of connectors and components utilizing connector interfaces. The interfaces detailed within this document have been coordinated and accepted by all military services and are deemed United States standards for radio frequency connector interfaces.

6.2 Patent notice. The Government has a royalty-free license under the following listed patents for the benefit of manufacturers of the item either for the Government or for use in equipment to be delivered to the Government. U.S. patent number 4,426,127 applies to series BMA interfaces. U.S. patent number 4,358,174 applies to series BMB interfaces.

U.S. patent number 4,426,127

U.S. patent number 4,358,174

6.3 Subject term (key word) listing.

Connector interfaces
Connector, radio frequency
Interfaces, radio frequency connector

6.4 Changes from previous issue. Asterisks are not used in this revision to identify changes with respect to the previous issue due to the extensiveness of the changes.

MIL-STD-348A
 NOTICE 1

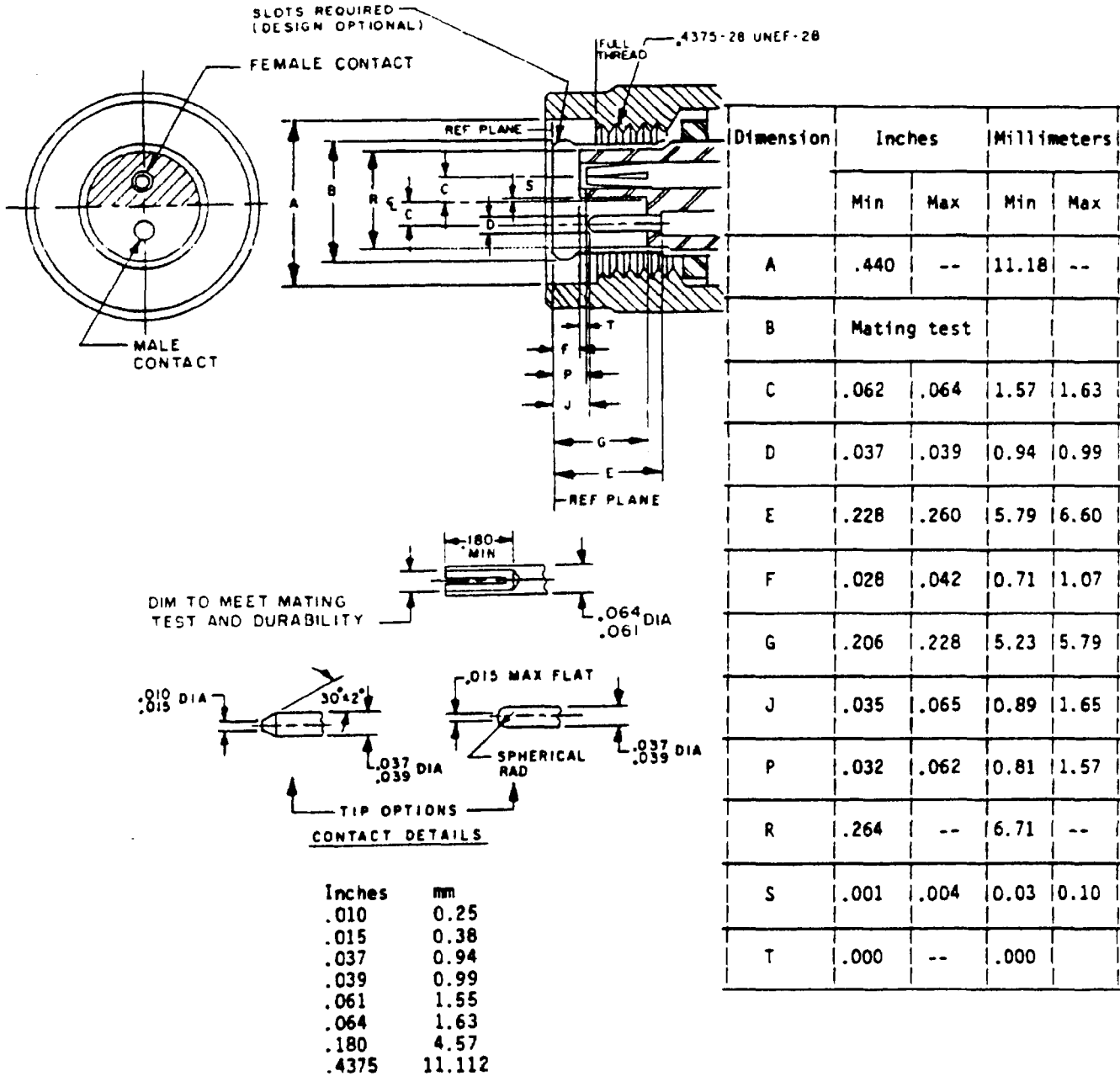

- NOTES:
1. Three holes equally spaced, .027 (0.69 mm) minimum diameter for safety wiring. Location on coupling nut optional.
 2. This interface shall meet the gauge requirements as specified in MIL-C-3655/14.

FIGURE 101-1. Interface, series TWTNC, coupling nut.

MIL-STD-348A
 NOTICE 1

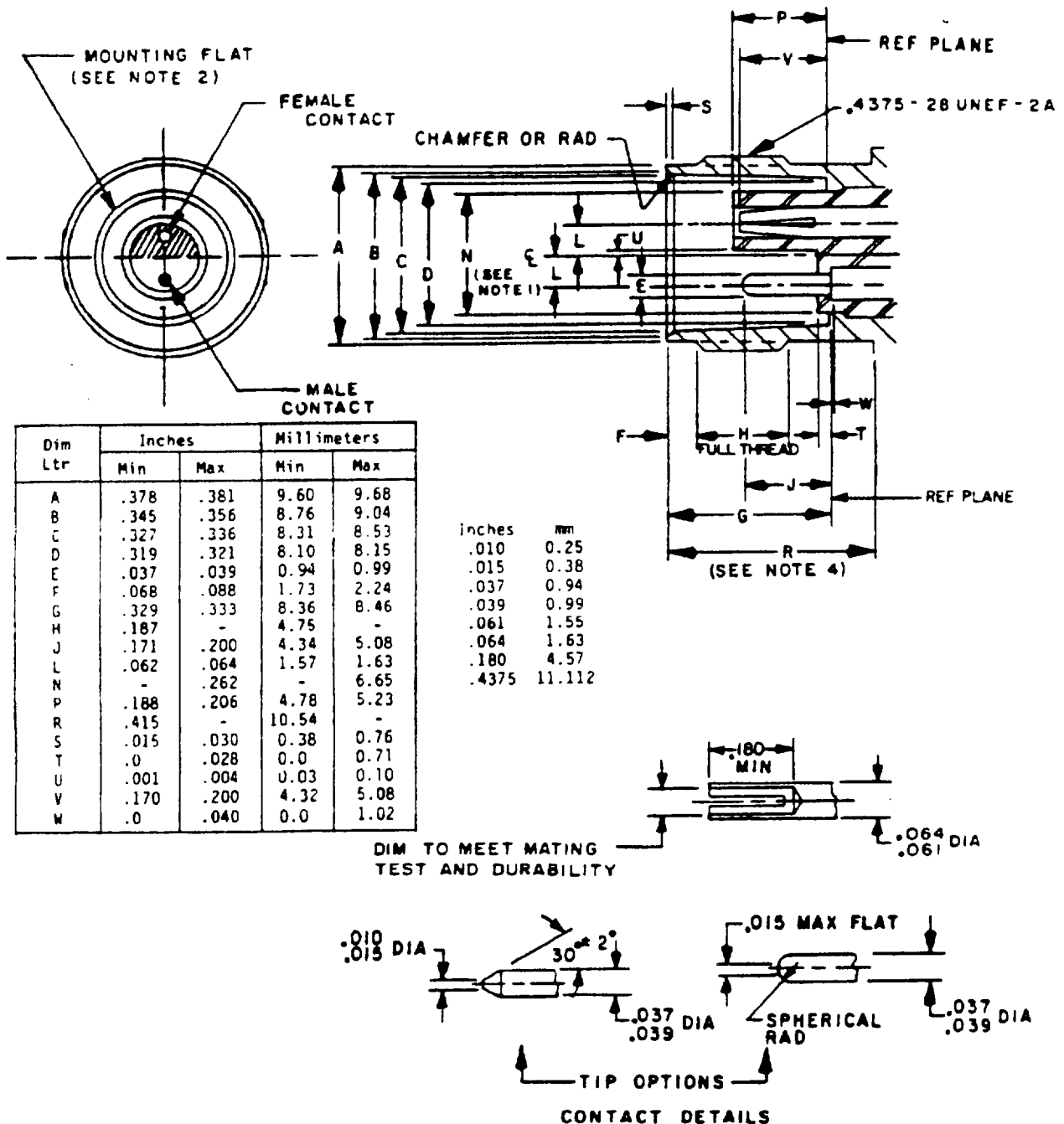

- NOTES:
1. N dimension applies to portion of dielectric protruding beyond reference plane.
 2. Contacts, insulator, and mounting flat shall be oriented within $\pm 3^\circ$ of orientation shown.
 3. This interface shall meet the gauge requirements as specified in MIL-C-3655/13.
 4. Clearance for mating connector coupling nut.

FIGURE 101-2. Interface, series TWNC, no coupling nut.

MIL-STD-348A
 NOTICE 1

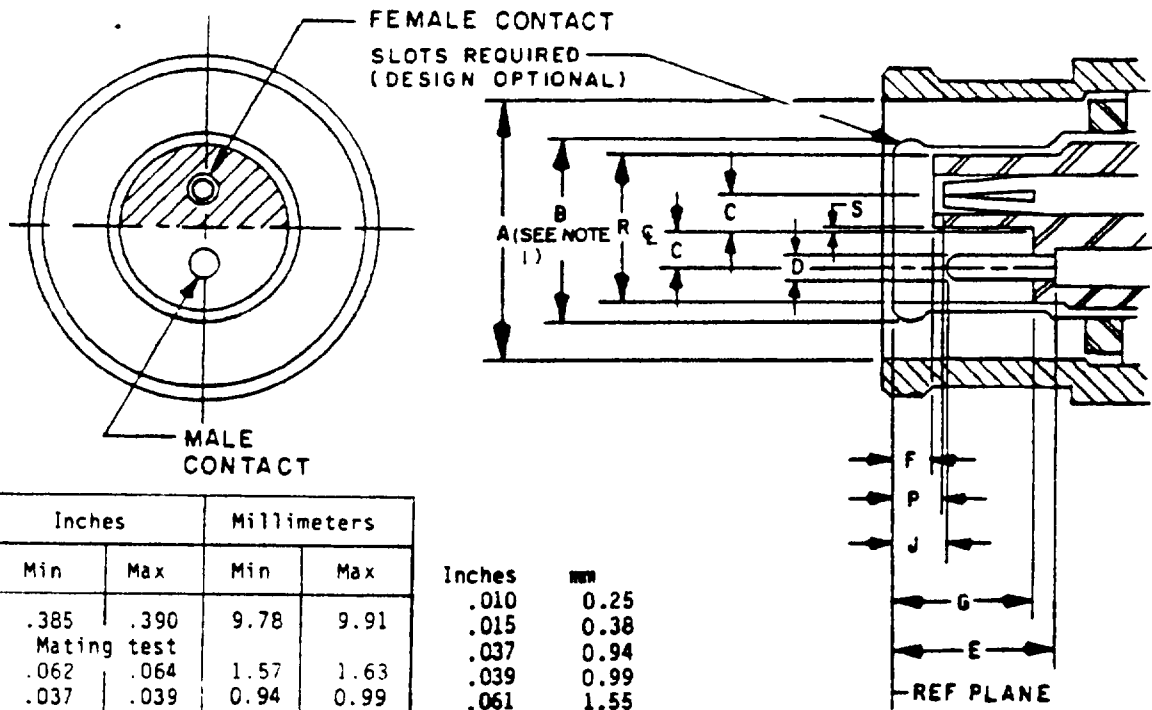

Dim Ltr	Inches		Millimeters	
	Min	Max	Min	Max
A	.385	.390	9.78	9.91
B	Mating test			
C	.062	.064	1.57	1.63
D	.037	.039	0.94	0.99
E	.228	.260	5.79	6.60
F	.028	.042	0.71	1.07
G	.206	.228	5.23	5.79
J	.035	.065	0.89	1.65
P	.032	.062	0.81	1.57
R	.264	-	6.71	-
S	.001	.004	0.03	0.10

Inches	mm
.010	0.25
.015	0.38
.037	0.94
.039	0.99
.061	1.55
.064	1.63
.180	4.57

DIM TO MEET MATING TEST AND DURABILITY

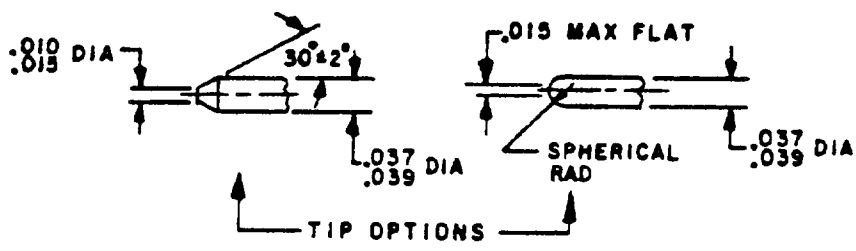
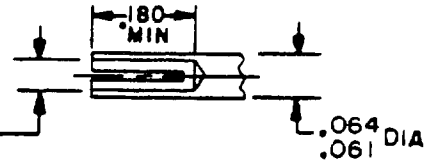

TIP OPTIONS
 CONTACT DETAILS

- NOTES:
1. Flare to meet gauge test.
 2. This interface shall meet the gauge requirements as specified in MIL-C-3655/15.

FIGURE 102-1. Interface, series TWBNC, with coupling nut.

MIL-STD-348A
 NOTICE 1

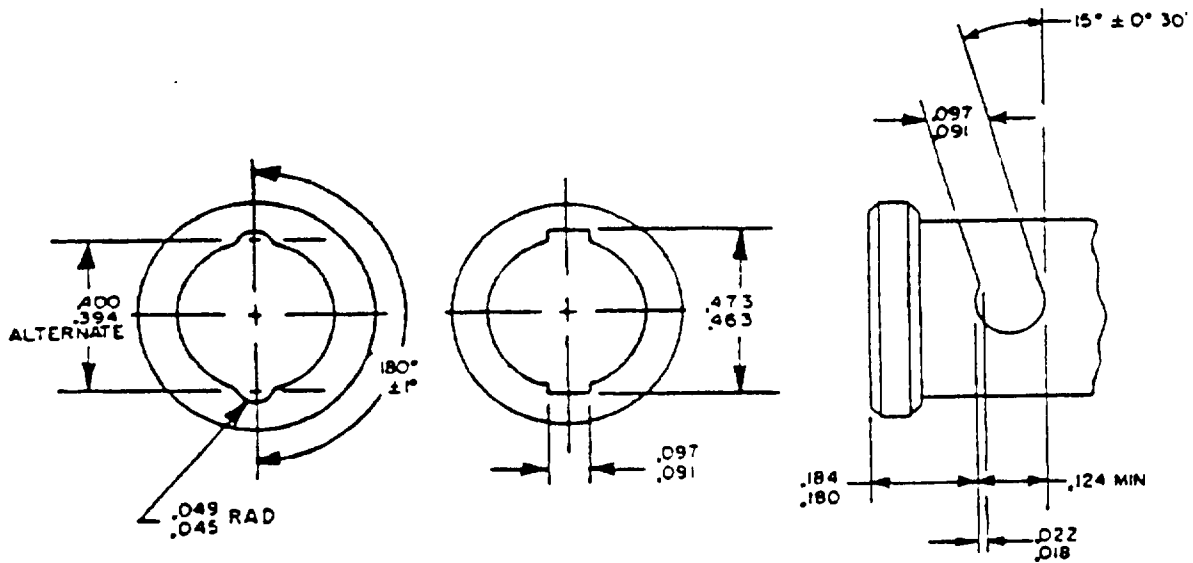

Inches	mm	Inches	mm
.018	0.46	.180	4.57
.022	0.56	.184	4.67
.045	1.14	.394	10.01
.049	1.24	.400	10.16
.091	2.31	.463	11.76
.097	2.46	.473	12.01
.124	3.15		

FIGURE 102-2. Interface, series TWBNC, coupling nut.

MIL-STD-348A
 NOTICE 1

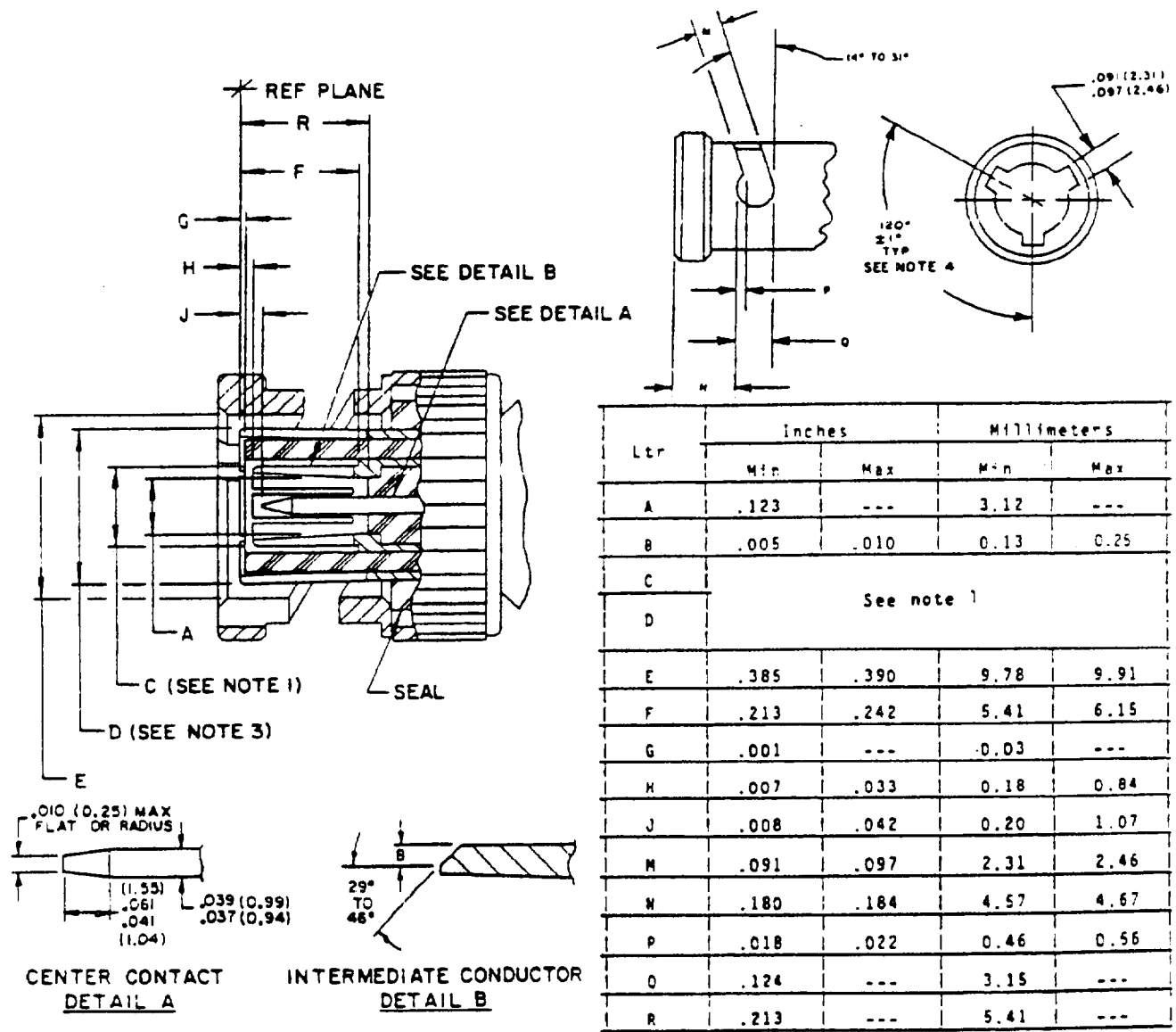

- NOTES:
1. Flared to meet mating characteristic test.
 2. Metric equivalents are in parentheses or tabulated.
 3. This interface shall meet the gauge requirements of MIL-C-49142.
 4. Standard polarization, see MIL-C-49142 for other options.

FIGURE 201-1. Interface, series, TRB, pin contact.

MIL-STD-348A
 NOTICE 1

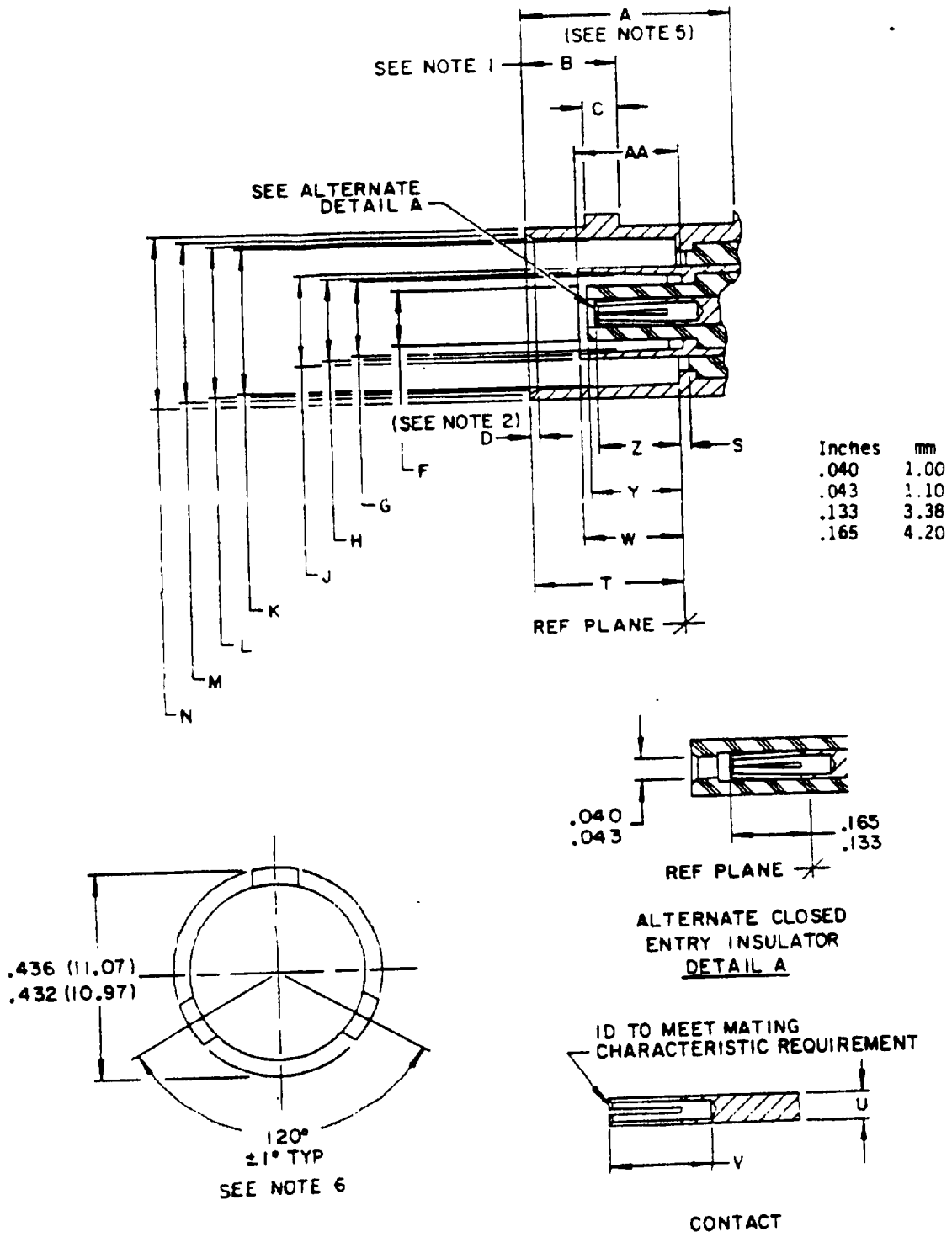

FIGURE 201-2. Interface, series TRB, socket contact.

MIL-STD-348A
 NOTICE 1

Ltr	Inches		Millimeters	
	Min	Max	Min	Max
A	.414	---	10.52	---
AA	.206	.213	5.23	5.41
B	.204	.208	5.18	5.28
C	.075	.081	1.90	2.06
D	.015	.030	0.38	0.76
F	.117	.122	2.97	3.10
G	.169	.171	4.29	4.34
H	.178	.182	4.52	4.62
J	.195	.199	4.95	5.05
K	.319	.321	8.10	8.15
L	.327	.333	8.31	8.46
M	.346	.356	8.79	9.04
N	.378	.382	9.60	9.70
S	.001	---	0.03	---
T	.327	.335	8.31	8.51
U	.062	.064	1.57	1.63
V	.200	---	5.08	---
W	.187	.213	4.75	5.41
Y	---	.213	---	5.41
Z	.165	.203	4.19	5.16

NOTES:

1. .005 (0.13 mm) flat permissible to meet dimension B.
2. Chamfer or radius.
3. Metric equivalents are in parentheses or tabulated.
4. This interface shall meet the gauge requirements of MIL-C-49142.
5. Clearance for mating connector coupling nut.
6. Standard polarization, see MIL-C-49142 for other options.

FIGURE 201-2. Interface, series TRB, socket contact - Continued.

MIL-STD-348A
 NOTICE 1

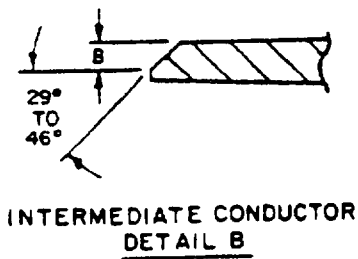
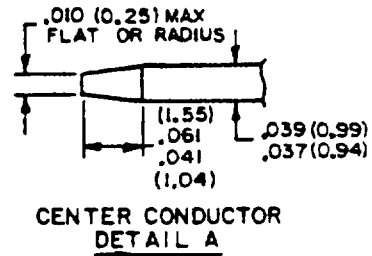
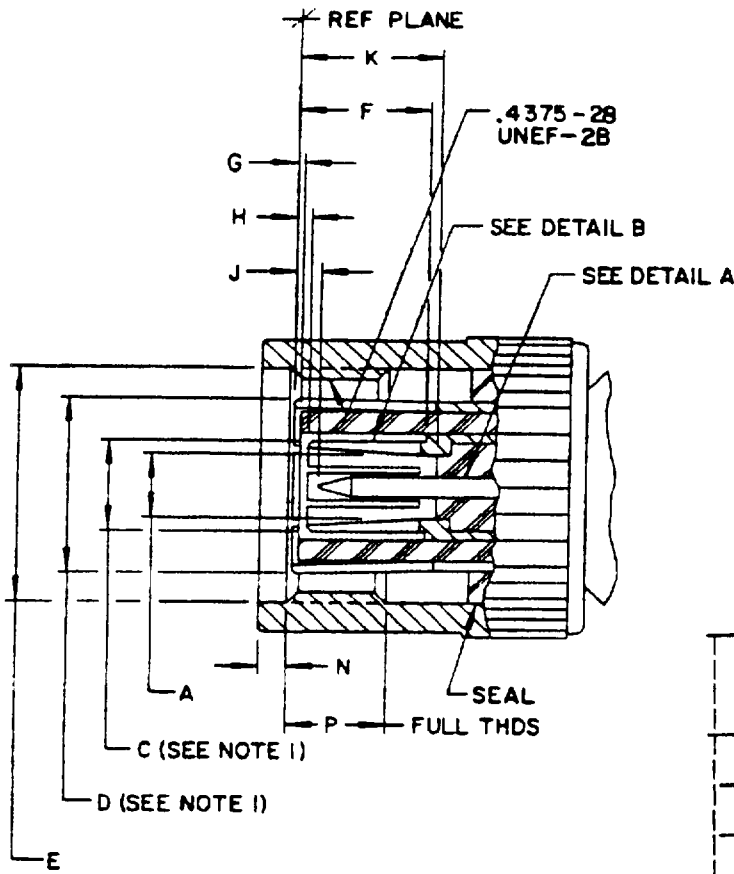

Ltr	Inches		Millimeters	
	Min	Max	Min	Max
A	.123	---	3.12	---
B	.005	.010	0.13	0.25
C	See note 1			
D				
E	.440	---	11.18	---
F	.213	.242	5.41	6.15
G	.001	---	0.03	---
H	.007	.033	0.18	0.84
J	.008	.042	0.20	1.07
K	.213	---	5.41	---
N	.063	---	1.60	---
P	.156	---	3.96	---

NOTES:

1. Flared to meet mating characteristic test.
2. Metric equivalents are in parentheses or tabulated.
3. This interface shall meet the gauge requirements of MIL-C-49142.

FIGURE 202-1. Interface, series TRT, pin contact.

MIL-STD-348A
 NOTICE 1

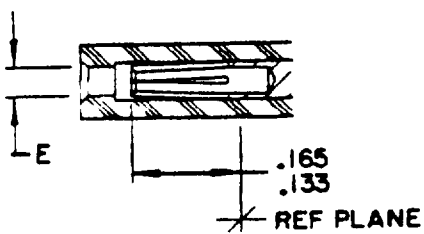
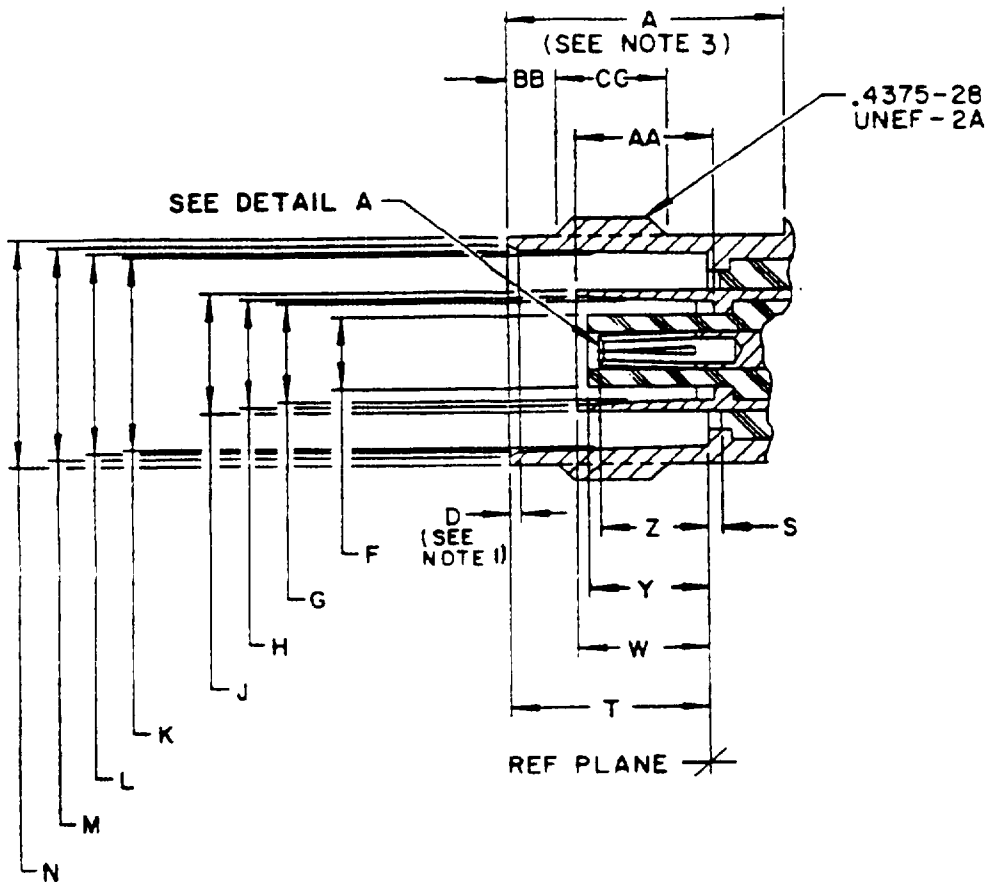

ALTERNATE CLOSED
 ENTRY INSULATOR
 DETAIL A

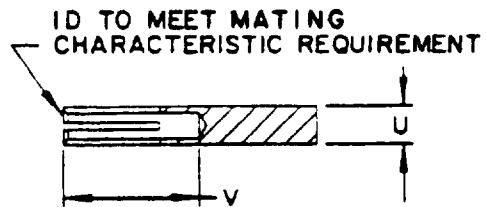

CONTACT

FIGURE 202-2. Interface, series TRT, socket contact.

**MIL-STD-348A
 NOTICE 1**

Ltr	Inches		Millimeters		Ltr	Inches		Millimeters	
	Min	Max	Min	Max		Min	Max	Min	Max
A	.414	---	10.52	---	S	.001	---	0.03	---
D	.015	.030	0.38	0.76	T	.327	.335	8.31	8.51
E	.040	.043	1.02	1.09	U	.062	.064	1.57	1.63
F	.117	.122	2.97	3.10	V	.200	---	5.08	---
G	.169	.171	4.29	4.34	W	.187	.213	4.75	5.41
H	.178	.182	4.52	4.62	Y	---	.213	---	5.41
J	.195	.199	4.95	5.05	Z	.165	.203	4.19	5.15
K	.319	.321	8.10	8.15	AA	.206	.213	5.23	5.41
L	.327	.333	8.31	8.46	BB	.068	.088	1.73	2.24
M	.346	.356	8.79	9.04	CC	.187	---	4.75	--
N	.378	.382	9.60	9.70					

NOTES:

1. Chamfer or radius.
2. This interface shall meet the gauge requirements of MIL-C-49142.
3. Clearance for mating connector coupling nut.

FIGURE 202-2. Interface, series TRT, socket contact - Continued.

MIL-STD-348A
NOTICE 1

SECTION 300

Interface Dimensions for MIL-C-3643, MIL-C-3650, MIL-C-26637,
MIL-C-39012, MIL-A-55339, and MIL-C-83517

Section 301	Series BNC
Section 302	Series C
Section 303	Series MHV
Section 304	Series N
Section 305	Series QL
Section 306	Series QM
Section 307	Series QNC
Section 308	Series QSC
Section 309	Series SC
Section 310	Series SMA
Section 311	Series SMB
Section 312	Series SMC
Section 313	Series TNC
Section 314	Series SHV
Section 315	Series LC
Section 316	Environment resistant
Section 317	Series HN
Section 318	Series LT
Section 319	Series SSMA
Section 320	Series SSMB
Section 321	Series BMA
Section 322	Series BMB

Supersedes section 300 of MIL-STD-348A

MIL-STD-348A
 NOTICE 1

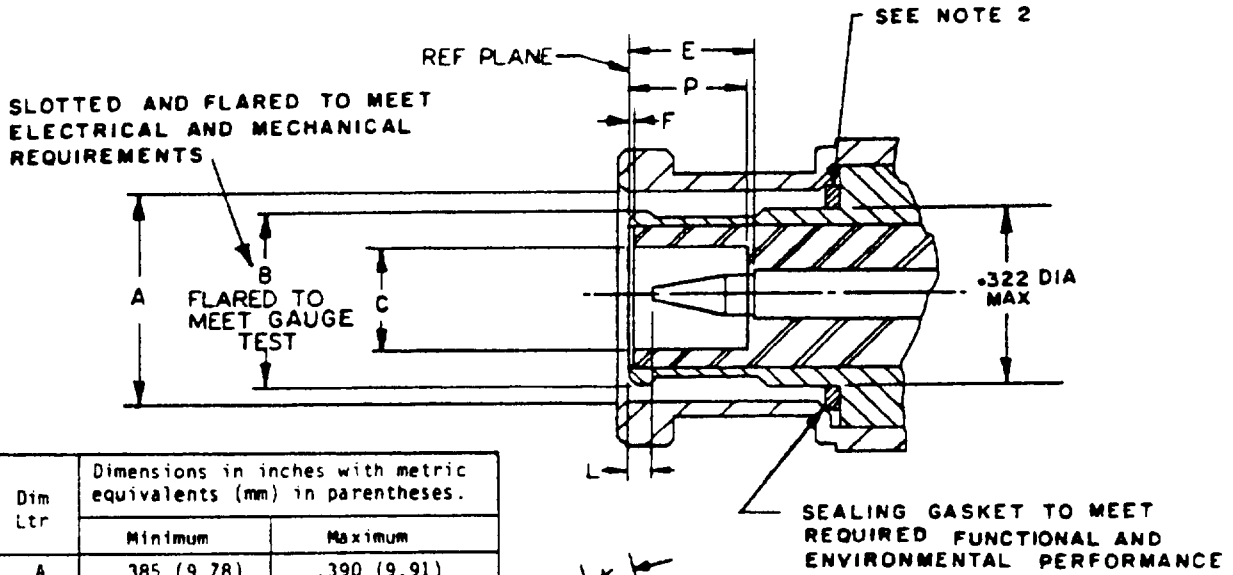

Dim Ltr	Dimensions in inches with metric equivalents (mm) in parentheses.	
	Minimum	Maximum
A	.385 (9.78)	.390 (9.91)
B	Gauge test	
C	.190 (4.83)	
D	.052 (1.32)	.054 (1.37)
E	.210 (5.33)	.230 (5.84)
F	.006 (0.15)	
G	.091 (2.31)	.097 (2.46)
H	.463 (11.76)	.473 (12.01)
H*	.394 (10.01)	.400 (10.16)
J	.124 (3.15)	
K	.091 (2.31)	.097 (2.46)
L	.003 (0.08)	
M	.018 (0.46)	.022 (0.56)
N		.025 (0.64)
P	.208 (5.28)	.228 (5.79)
Q	.078 (1.98)	
R	.081 (2.06)	.087 (2.21)
T	.045 (1.14)	.049 (1.24)
U	.180 (4.57)	.184 (4.67)

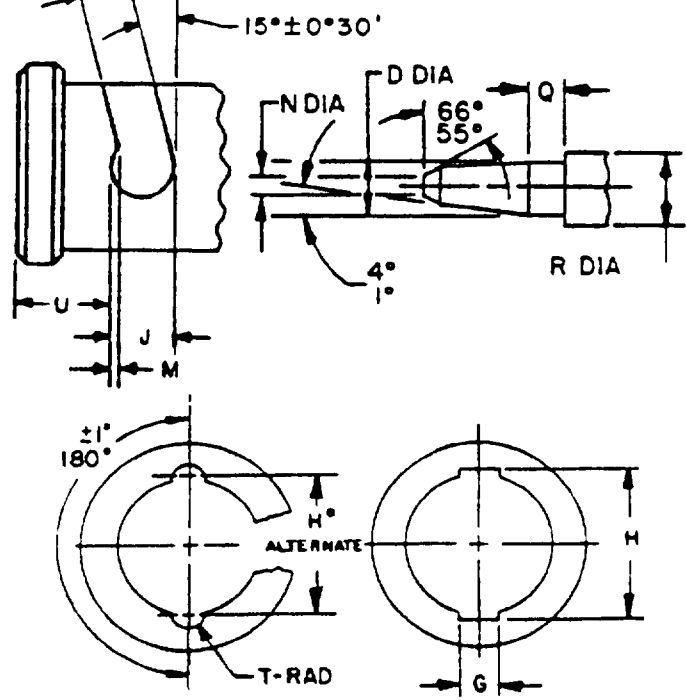

- NOTES:
1. In the mated condition, the longitudinal force of the spring of the coupling mechanism shall exceed the pressure exerted by the sealing gasket by an amount necessary to insure butting of the outer contacts at the reference plane.
 2. This interface shall meet the gauge requirements as specified in MIL-C-39012/16.

FIGURE 301-1. Interface, series BNC, pin contact.

MIL-STD-348A
 NOTICE 1

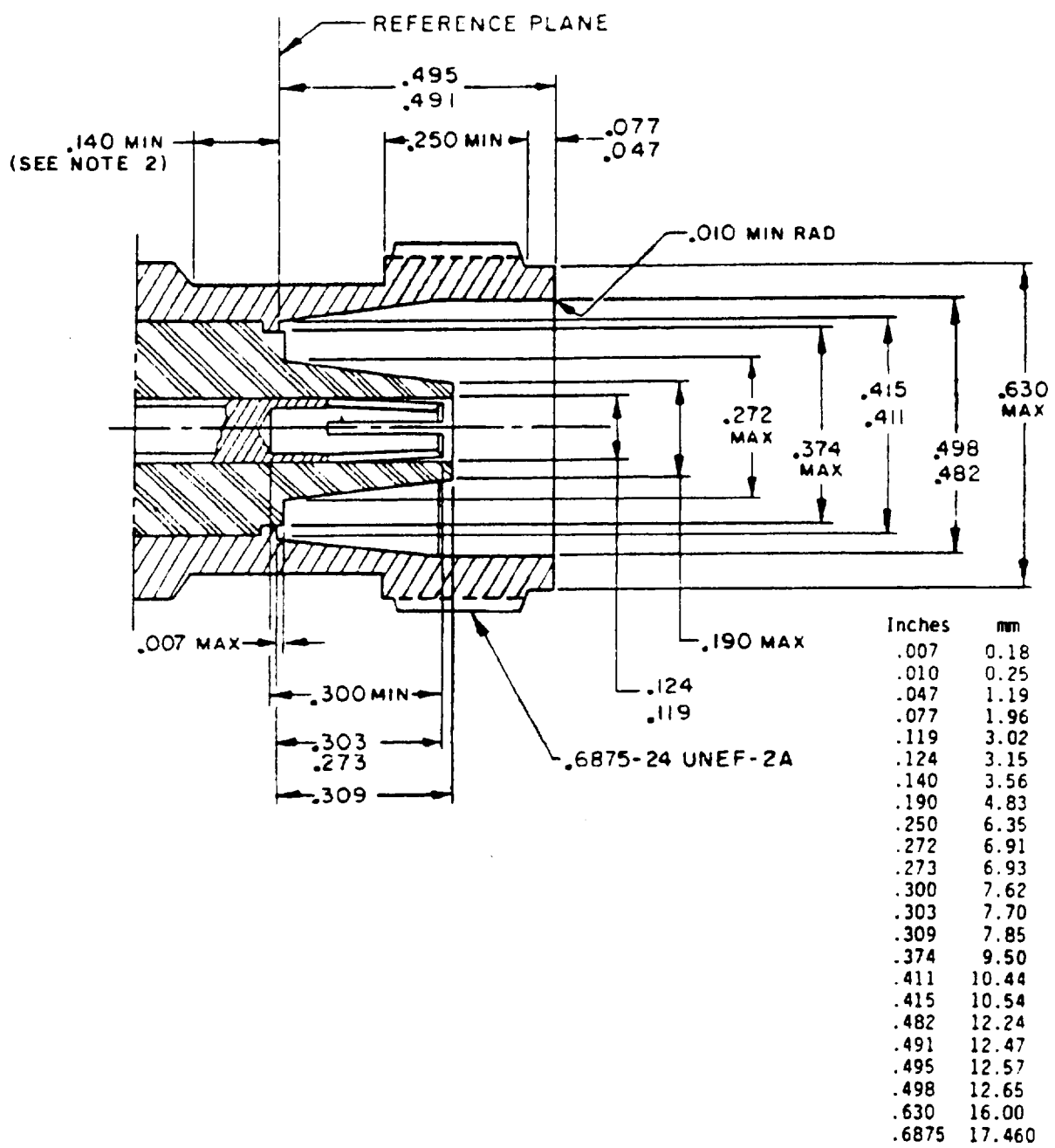

- NOTES:
 1. This interface shall meet the gauge requirements as specified in MIL-C-39012/40.
 2. Clearance for mating connector coupling nut.

FIGURE 309-2. Interface, series SC, socket contact.

MIL-STD-348A
 NOTICE 1

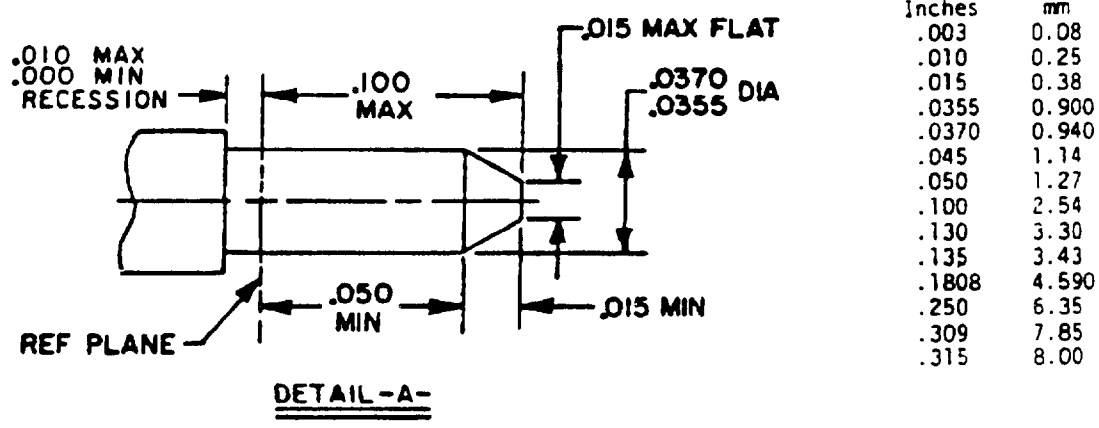
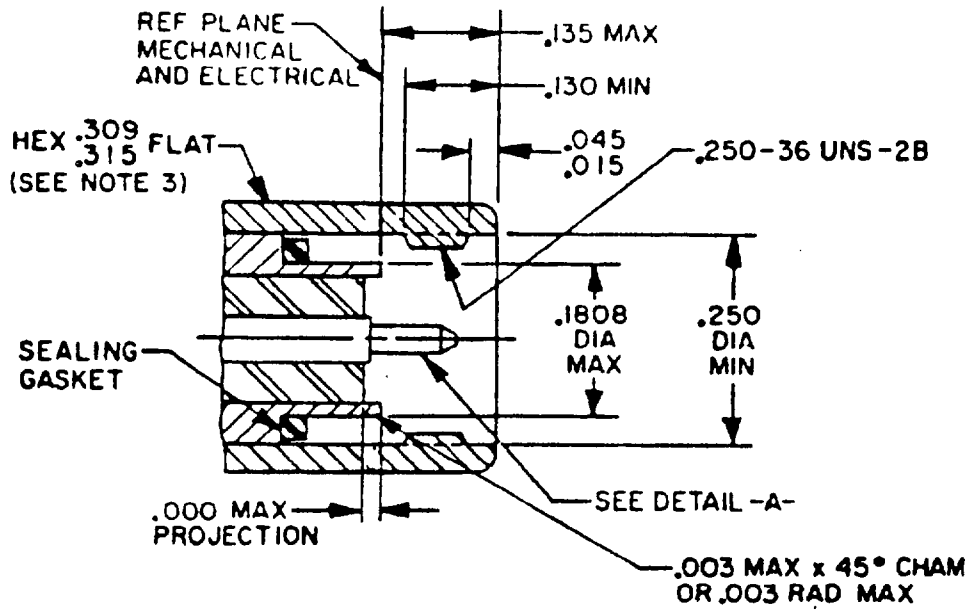

- NOTES:
1. This interface shall meet the gauge requirements as specified in MIL-C-39012/79.
 2. Connector interfaces (after connector mating) shall be kept free from dust and moisture.
 3. May extend throughout the full length of the coupling nut.

FIGURE 310-1. Interface, series SMA, pin contact.

MIL-STD-348A
 NOTICE 1

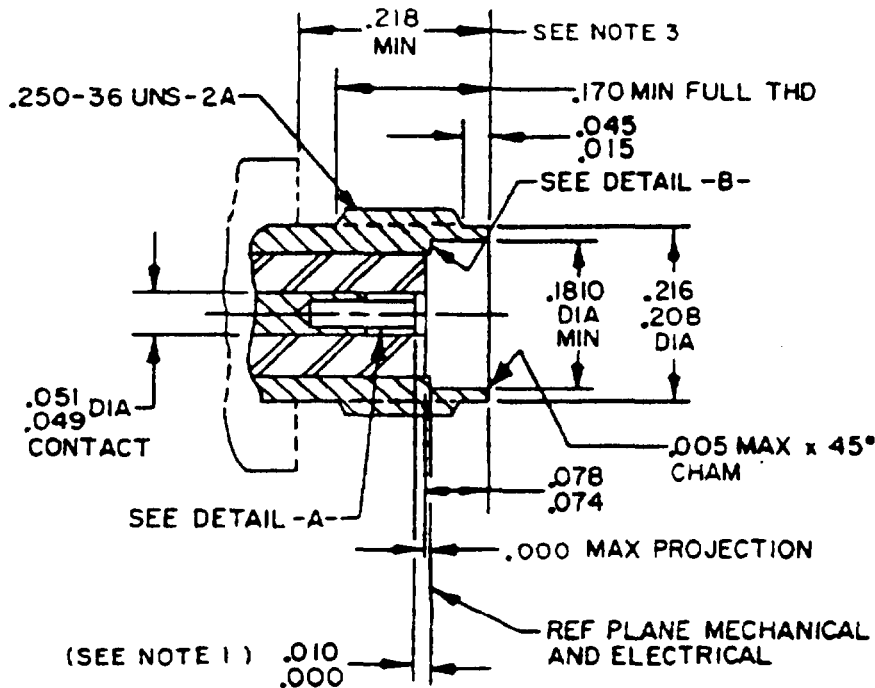

Inches	mm
.005	0.13
.010	0.25
.015	0.38
.0355	0.90
.0370	0.94
.045	1.14
.049	1.24
.051	1.29
.074	1.88
.078	1.98
.115	2.92
.168	4.27
.170	4.32
.1810	4.597
.208	5.28
.216	5.49
.218	5.54
.250	6.35

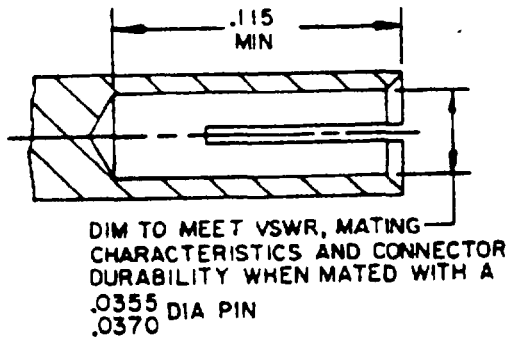

DETAIL-A-

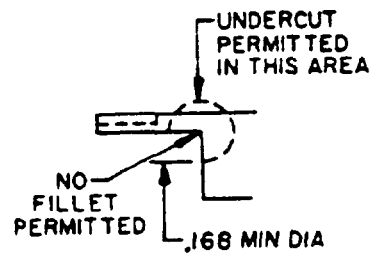

DETAIL-B-

NOTES:

1. Previously qualified parts utilizing a .030 inch maximum contact recession shall be acceptable for Government procurement up to 18 months from the date of this specification for existing designs only. Caution should be exercised to determine whether a thick wall (.030 inch recession) design is being used during maintenance and part replacement.
2. This interface shall meet the gauge requirements as specified in MIL-C-39012/83.
3. Clearance for mating connector coupling nut.

FIGURE 310-2. Interface, series SMA, socket contact.

MIL-STD-348A

NOTICE 1

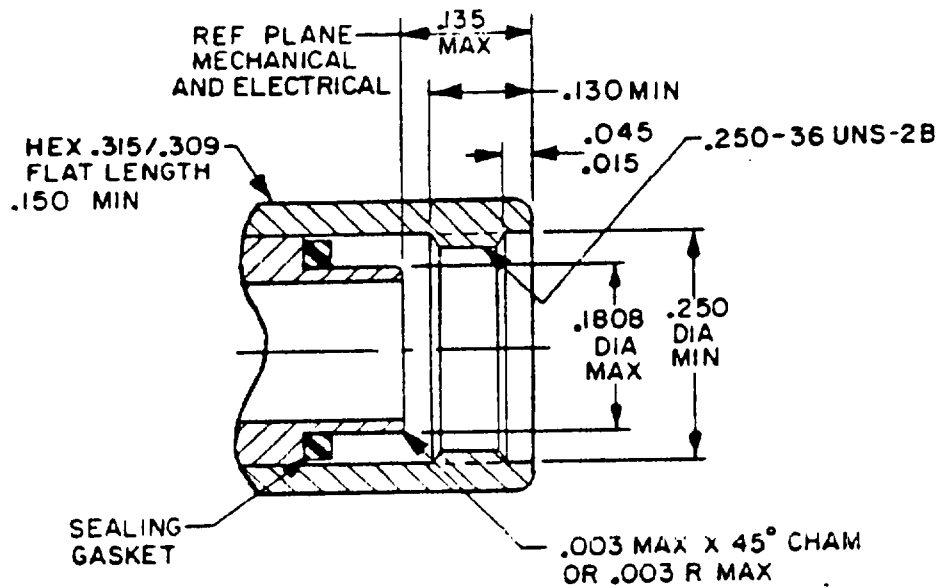

Inches	mm
.003	0.08
.015	0.38
.045	1.14
.130	3.30
.135	3.43
.150	3.81
.1808	4.59
.250	6.35
.309	7.85
.315	8.00

NOTES:

1. This interface shall meet the gauge requirements as specified in MIL-C-39012/92.
2. Reference MIL-C-39012/92 for cable stripping dimensions.

FIGURE 310-3. Interface, series SMA, no contact

MIL-STD-348A
 NOTICE 1

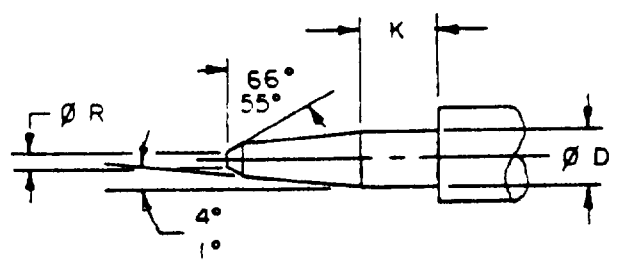
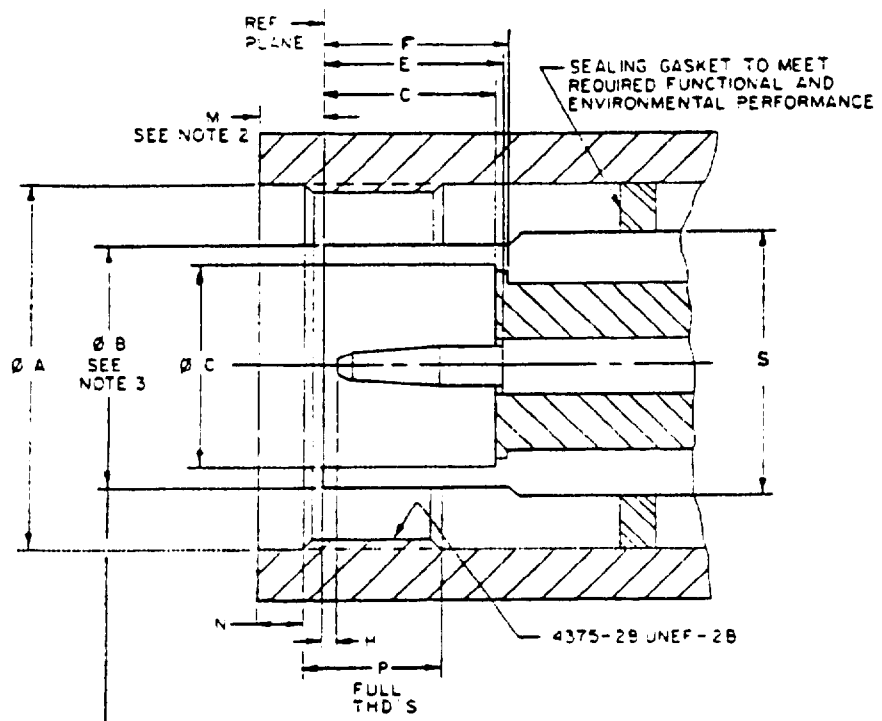

Ltr	Inches		Millimeters	
	Min	Max	Min	Max
A	.440		11.18	---
B	.314	.318	7.98	8.08
C	.238	.242	6.05	6.15
D	.052	.054	1.32	1.37
E	.208	---	5.28	
F	.212	---	5.38	
G	.208	---	5.28	
H	.003	.040	0.08	1.02
K	.078	---	1.98	
M		.078		1.98
N	.063		1.60	
P	.156		3.96	
R		.025		0.64
S		.322		8.18

- NOTES:
1. Three holes .027 inch minimum diameter equally spaced for safety wiring when required. Location on coupling nut is optional.
 2. Dimension with nut bias fully forward.
 3. For unslotted version. Slotted designs must meet gauge test, B dimension will not apply.

FIGURE 313-3. Interface, series TNCA, pin contact, air interface.

MIL-STD-348A
 NOTICE 1

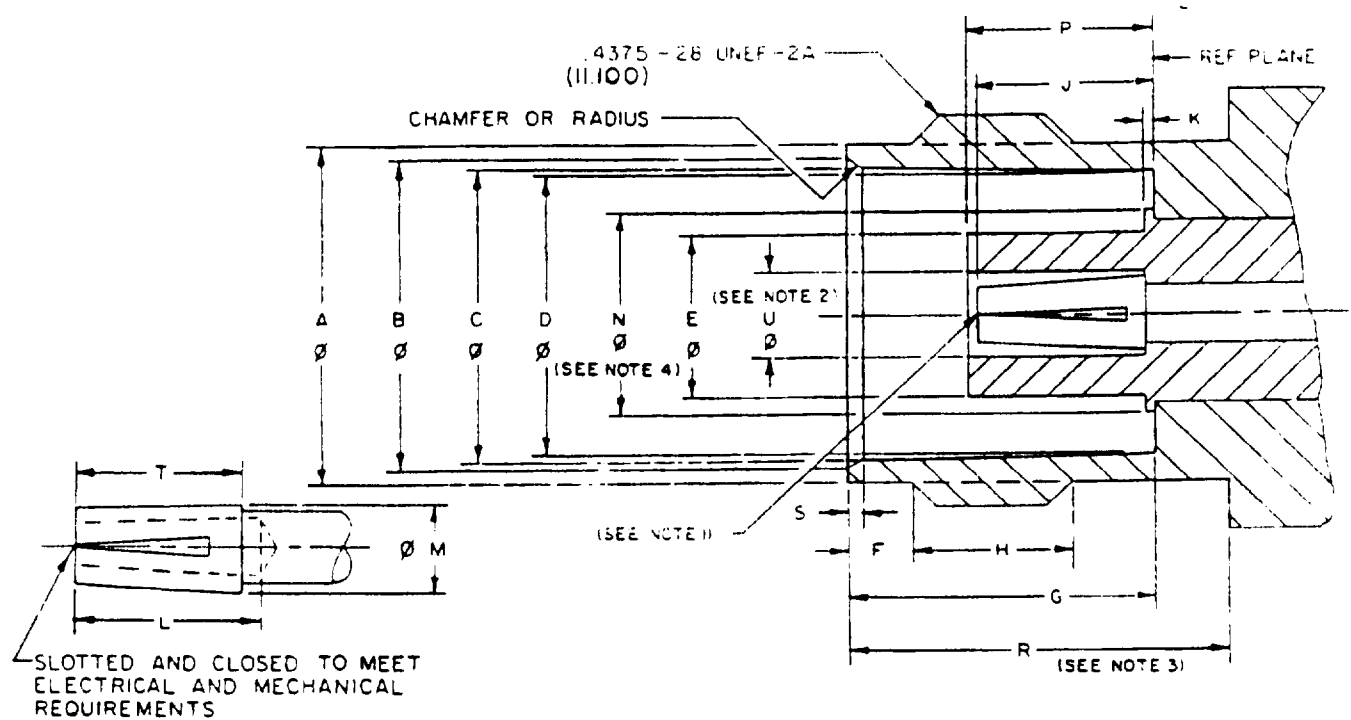

Ltr	Inches		Millimeters	
	Min	Max	Min	Max
A	.378	.381	9.60	9.68
B	.346	.356	8.79	9.04
C	.327	.333	8.31	8.46
D	.319	.321	8.10	8.15
E	.182	.186	4.62	4.72
F	.068	.088	1.73	2.24
G	.327	.335	8.31	8.51
H	.187	---	4.75	--
J	.198	.208	.208	5.28

Ltr	Inches		Millimeters	
	Min	Max	Min	Max
K	---	.006	---	0.15
L	.195	---	4.95	--
M	.084	.087	2.13	2.21
N	---	.230		5.84
P	.198	.208	5.03	5.28
R	.414		10.52	--
S	.015	.030	.030	0.76
T	.180	.196	.196	4.98
U	---	.092	---	2.34

- NOTES:
1. I.D. to meet VSWR when mated with .052 (1.32 mm) -.054 (1.37 mm) diameter pin.
 2. Diameter is I.D. of dielectric.
 3. Clearance for mating connector coupling nut.
 4. Applies to portion of dielectric which protrudes beyond metal shoulder (reference plane).

FIGURE 313-4. Interface, series TNCA, socket contact, air interface.

MIL-STD-348A
 NOTICE 1

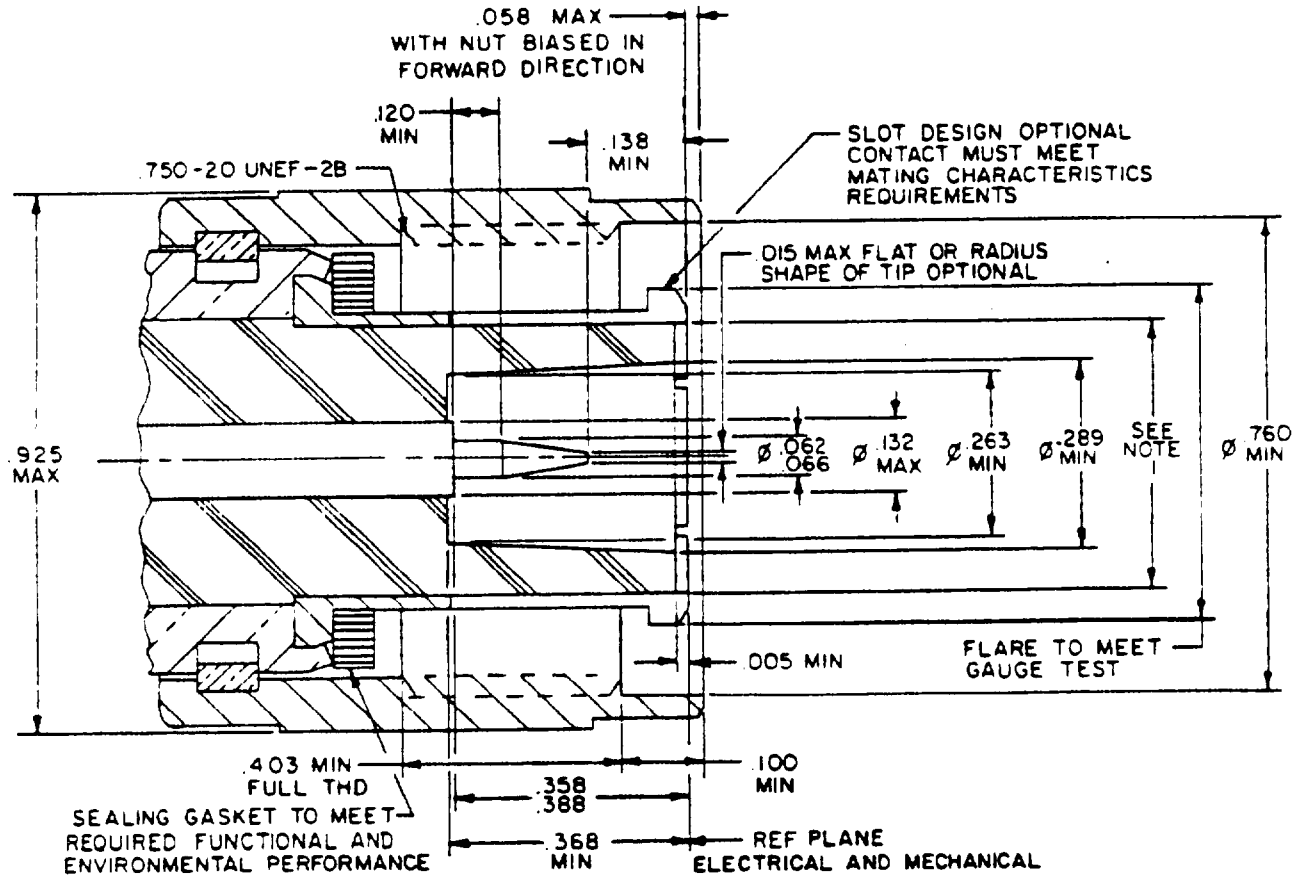

Inches	mm	Inches	mm
.005	0.13	.289	7.33
.015	0.38	.358	9.10
.058	1.48	.368	9.33
.062	1.58	.388	9.85
.066	1.68	.403	10.22
.100	2.54	.432	10.98
.120	3.03	.548	13.90
.132	3.35	.750	19.05
.138	3.50	.760	19.30
.263	6.69	.925	23.50

NOTE: I.D. of outer contact when inserted into a .548 maximum diameter ring gauge shall be .432 minimum.

FIGURE 317-1. Interface, series HN, pin contact.

MIL-STD-348A
 NOTICE 1

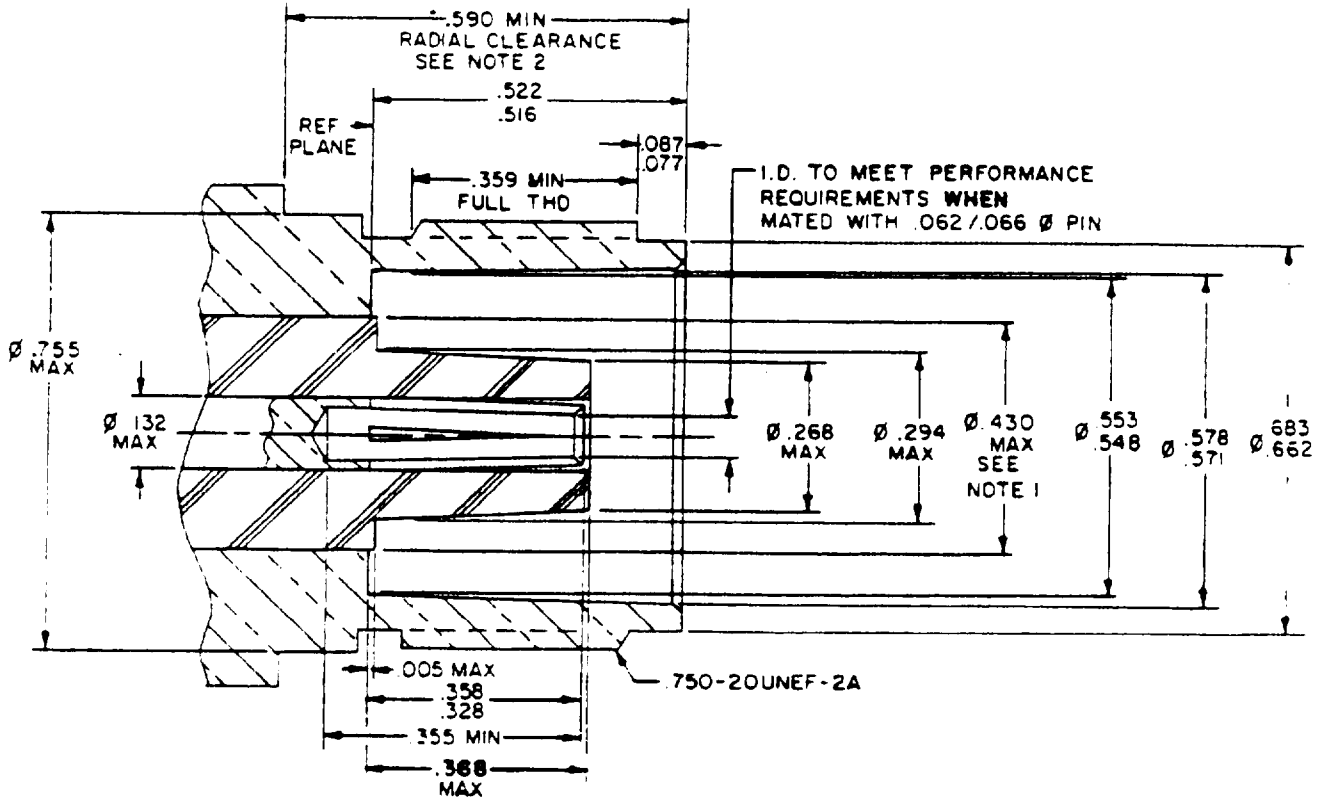

Inches	mm	Inches	mm
.005	0.13	.430	10.91
.062	1.58	.516	13.10
.066	1.68	.522	13.25
.077	1.95	.548	13.90
.087	2.20	.553	14.05
.132	3.35	.571	14.50
.268	6.80	.590	14.99
.328	8.32	.662	16.80
.355	9.00	.683	17.35
.358	9.10	.750	19.05
.359	9.11	.755	19.18
.368	9.35		

- NOTES:
1. Dielectric protrusion beyond reference plane.
 2. Clearance for mating connector coupling nut.

FIGURE 317-2. Interface, series MM, socket contact.

Supersedes page 317.2 of MIL-STD-348A

MIL-STD-348A
 NOTICE 1

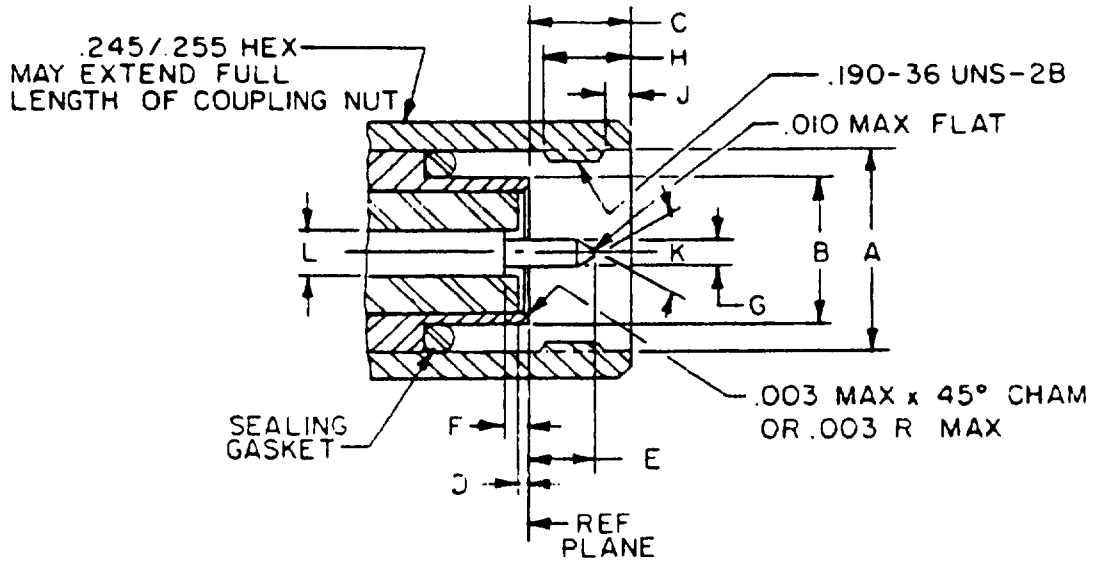

Ltr	Inches		Millimeters	
	Min	Max	Min	Max
A dia	.196	.202	4.98	5.13
B dia	.124	.1268	3.15	3.22
C	.100	1.33	2.54	3.38
D	.000	.010	0.00	0.25
E	.050	.065	1.27	1.65
F	.000	.010	0.00	0.25
G dia	.0195	.0208	0.495	0.529
H	.130	---	3.30	---
J	.015	0.45	0.38	1.14
K	70°	95°	70°	95°
L dia	.0335	.0348	0.851	0.884

Inches	mm
.003	0.08
.045	1.14
.190	4.83
.245	6.21
.255	6.48

FIGURE 319-1. Interface, series SSMA, pin contact.

MIL-STD-348A
 NOTICE 1

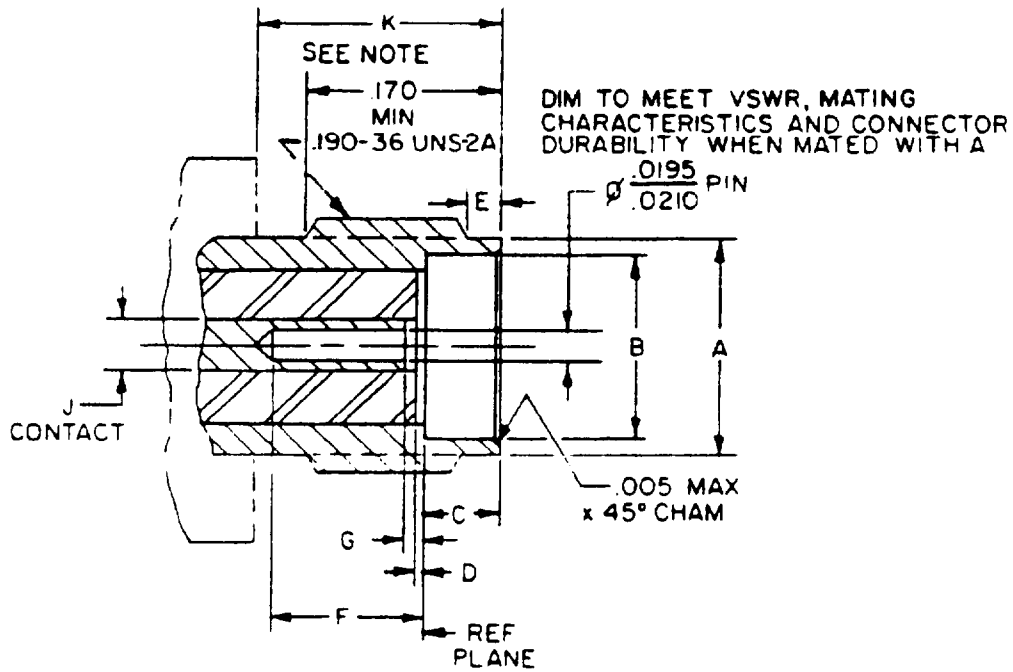

Inches	mm
.005	0.11
.0195	0.500
.0210	0.530
.170	4.30
.190	4.81

Ltr	Inches		Millimeters	
	Min	Max	Min	Max
A dia	.153	.160	3.89	4.06
B dia	.127	.130	3.23	3.30
C	.075	.077	1.90	1.96
D	.000	.010	0.00	0.25
E	.020	.040	0.51	1.02
F	.075	---	1.90	--
G	.000	.010	0.00	0.25
J dia	.0335	.0348	0.851	0.884
K	.230	---	5.84	---

NOTE: Clearance for coupling nut.

FIGURE 319-2. Interface, series SSMA, socket contact.

MIL-STD-348A
 NOTICE 1

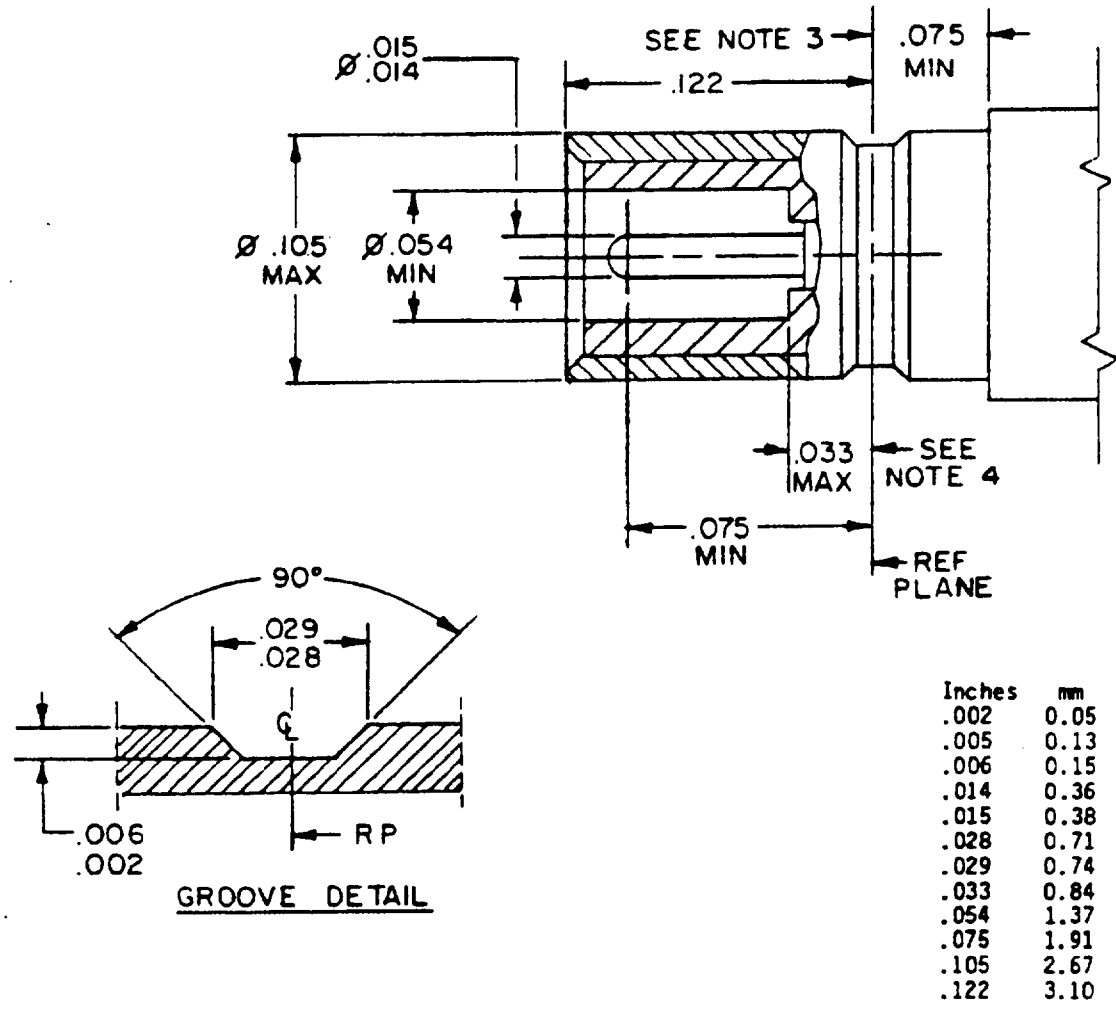

- NOTES:
1. All undimensioned pictorial representations are for reference purposes only.
 2. Unless otherwise specified, tolerances shall be $\pm .005$.
 3. Clearance for mating connector coupling nut.
 4. This dimension (.033 maximum) applies to both the insulator and the contact.

FIGURE 320-1. Interface, series SSMB, pin contact.

MIL-STD-348A
 NOTICE 1

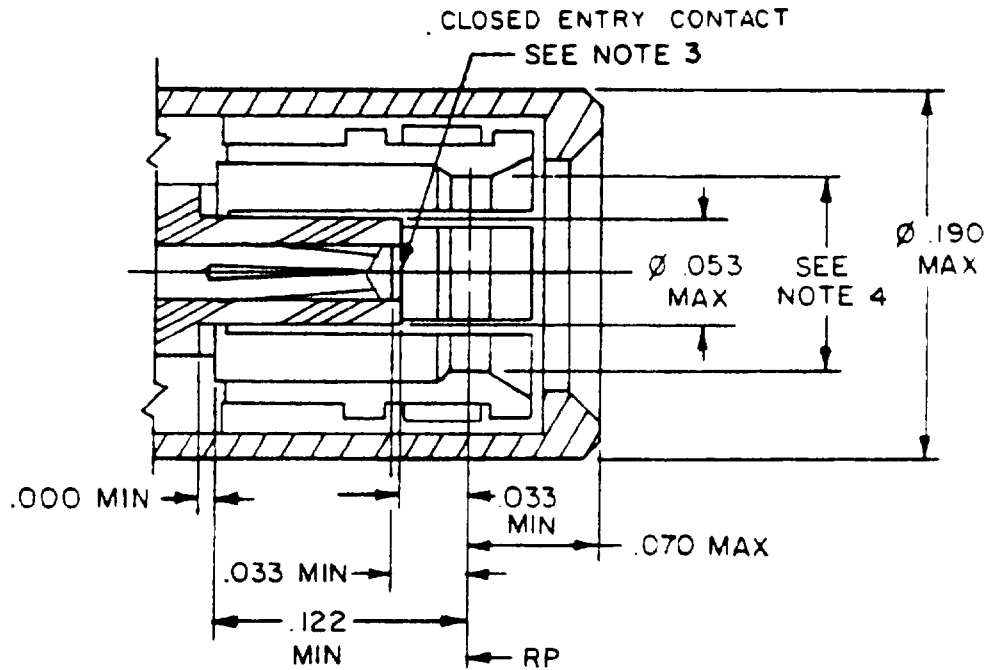

Inches	mm
.033	0.84
.053	1.34
.070	1.78
.122	3.10
.190	4.82

NOTES:

1. All undimensioned pictorial representations are for reference purposes only.
2. Unless otherwise specified, tolerances shall be ± 0.005 .
3. Inside diameter of contact to meet VSWR, mating characteristics and connector durability when mated with a .014 - .015 inch diameter male contact.
4. Must meet the force to engage/disengage requirement when mated with its mating part.

FIGURE 320-2. Interface, series SSMB, socket contact.

MIL-STD-348A
NOTICE 1

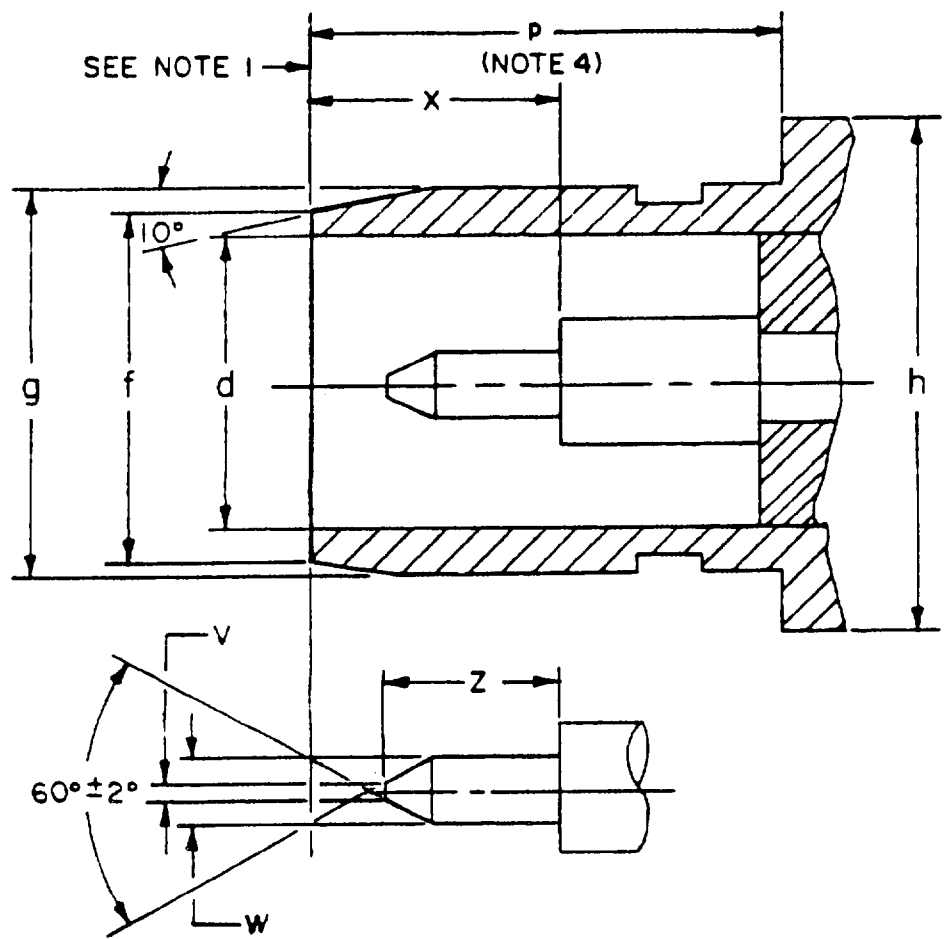
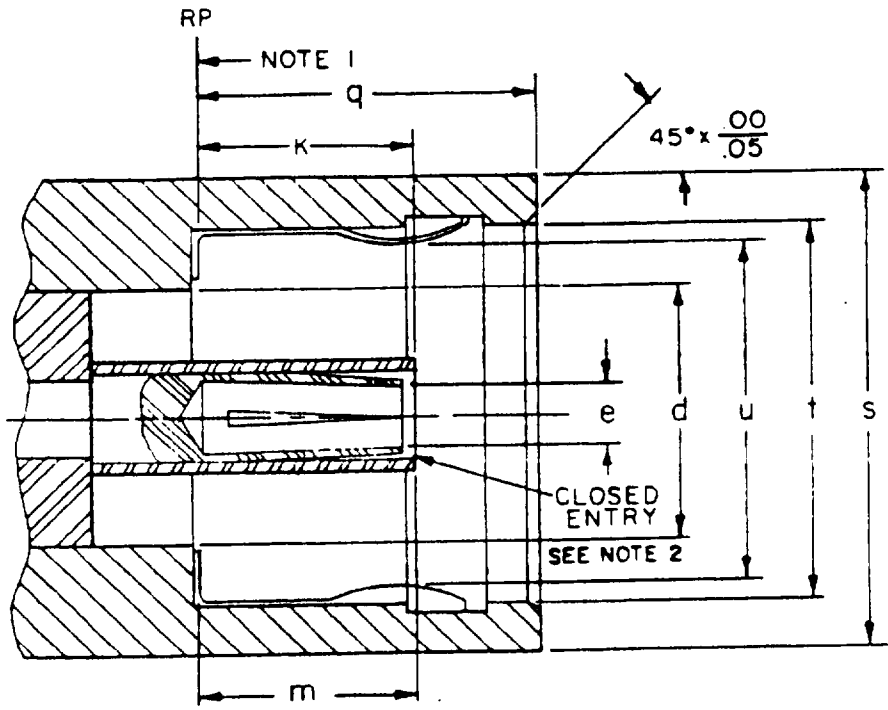

FIGURE 321-1. Interface, series BMA, pin contact.

MIL-STD-348A
 NOTICE 1



Inches	mm
.005	0.13
.010	0.25
.012	0.30
.0355	0.90
.0370	0.94
.115	2.92
.164	4.15
.184	4.68
.187	4.75
.222	5.64
.250	6.35
.278	7.05
.468	11.89

FIGURE 321-2. Interface, series BMA, socket contact.

**MIL-STD-348A
 NOTICE 1**

Ref	Inches		Millimeters		Notes
	Min	Max	Min	Max	
d	0.161 nom		4.08 nom		
e	---	--	---	--	2
f	0.192 nom		4.88 nom		
g	.209	.211	5.30	5.35	
h	0.300 nom		7.62 nom		
k	---	0.127	---	3.22	
m	0.115	---	2.92	---	
p	0.198	---	5.03	---	
q	---	0.195	---	4.95	3
s	0.290	---	7.37	---	
t	.225	---	5.71	---	
u	---	0.200	---	5.08	
v	---	0.015	---	0.38	
w	0.0354	0.0370	0.899	0.940	
x	0.128	---	3.25	---	
z	0.090 nom		2.29 nom		

NOTES:

1. Reference plane.
2. Bore diameter closed to meet electrical and mechanical requirements when mated with a 0.0355/0.0370 inch (0.902/0.940 mm) pin.
3. With spring finger bottomed.
4. Clearance for mating connector coupling nut.
5. Patent notice: See 6.2 for U.S. patent number 4,426,127.

FIGURE 321-3. Interface dimension table, series BMA.

MIL-STD-348A
 NOTICE 1

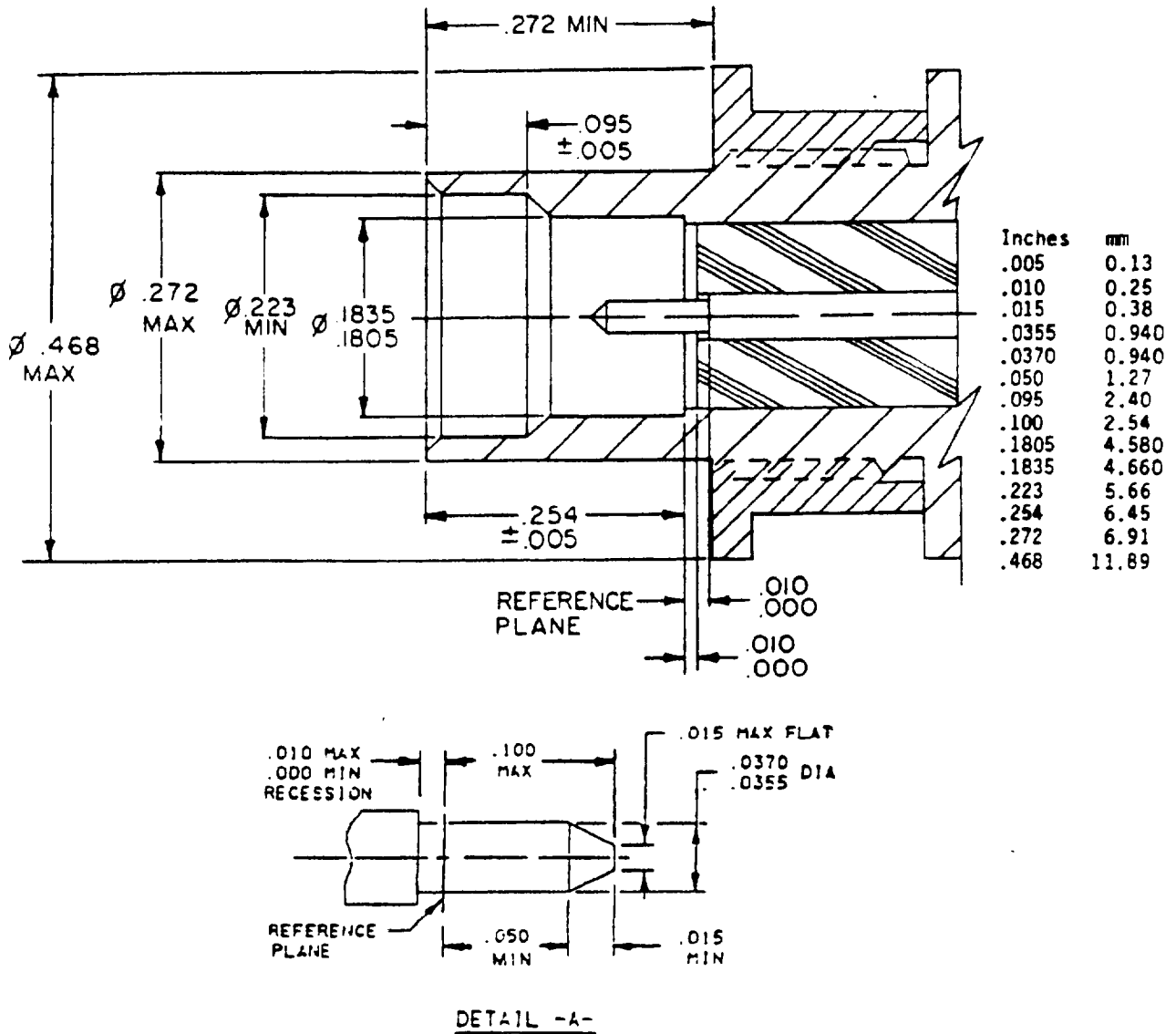

NOTES:

1. Patent notice: See 6.2 for U.S. patent number 4,358,174.
2. Unless otherwise specified, tolerance is $\pm .005$ (0.13 mm).

FIGURE 322-1. Interface, series BMB, pin contact.

MIL-STD-348A
 NOTICE 1

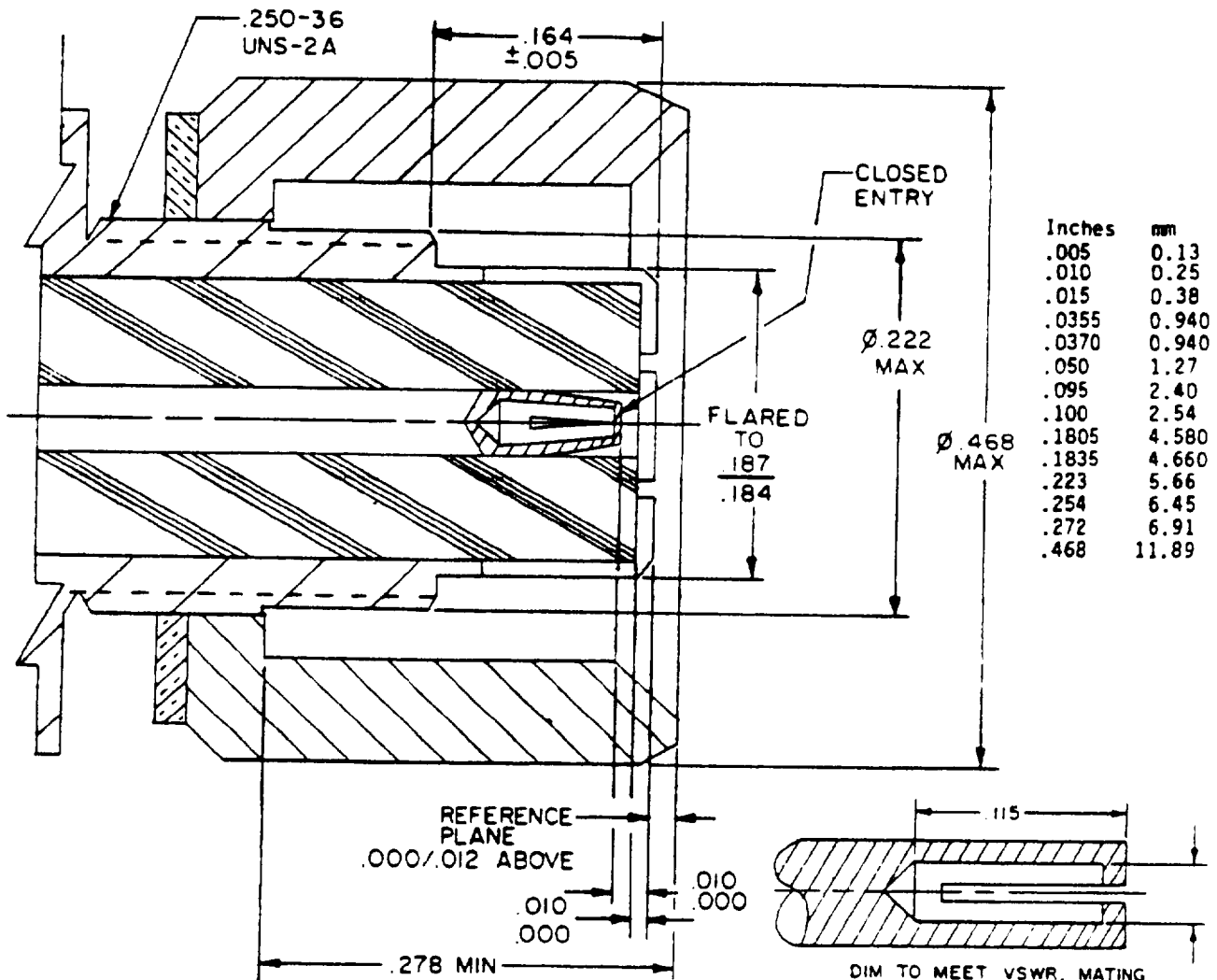

NOTES:

1. Patent notice: See 6.2 for U.S. patent number 4,358,174.
2. Unless otherwise specified, tolerance is *.005 (0.13 mm).

FIGURE 322-2. Interface, series BMB, socket contact.

MIL-STD-348A
 NOTICE 1

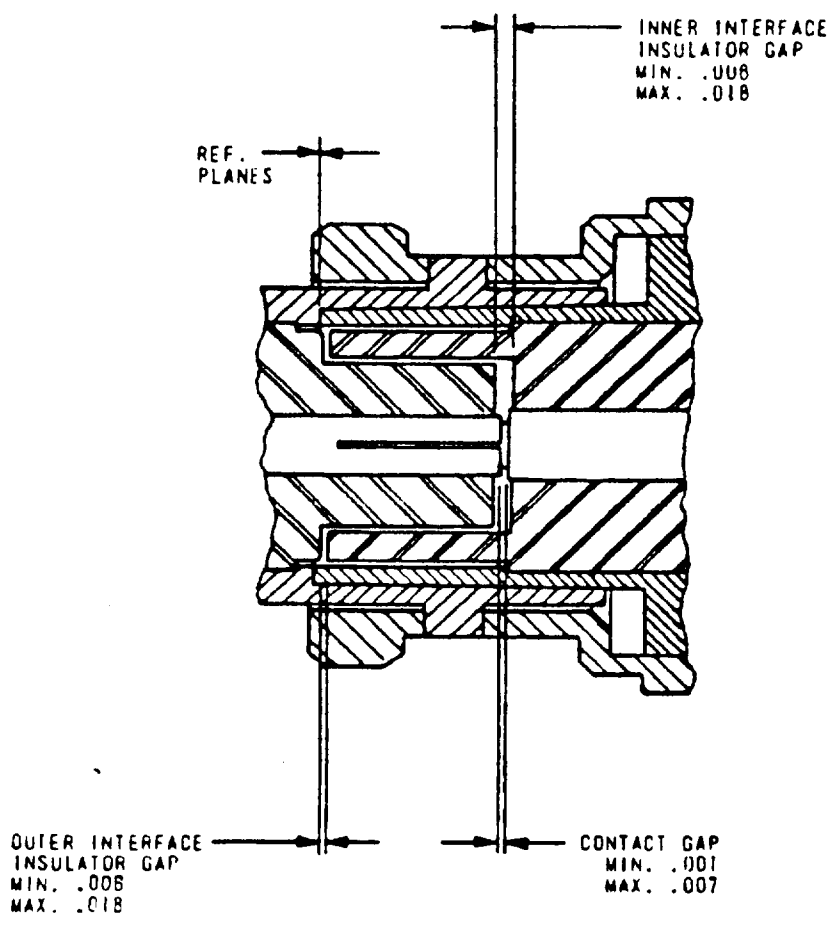

Inches	mm
.001	0.03
.006	0.15
.007	0.18
.018	0.46

FIGURE 404-3. Interface, mated test connector, series BNC.

MIL-STD-348A
 NOTICE 1

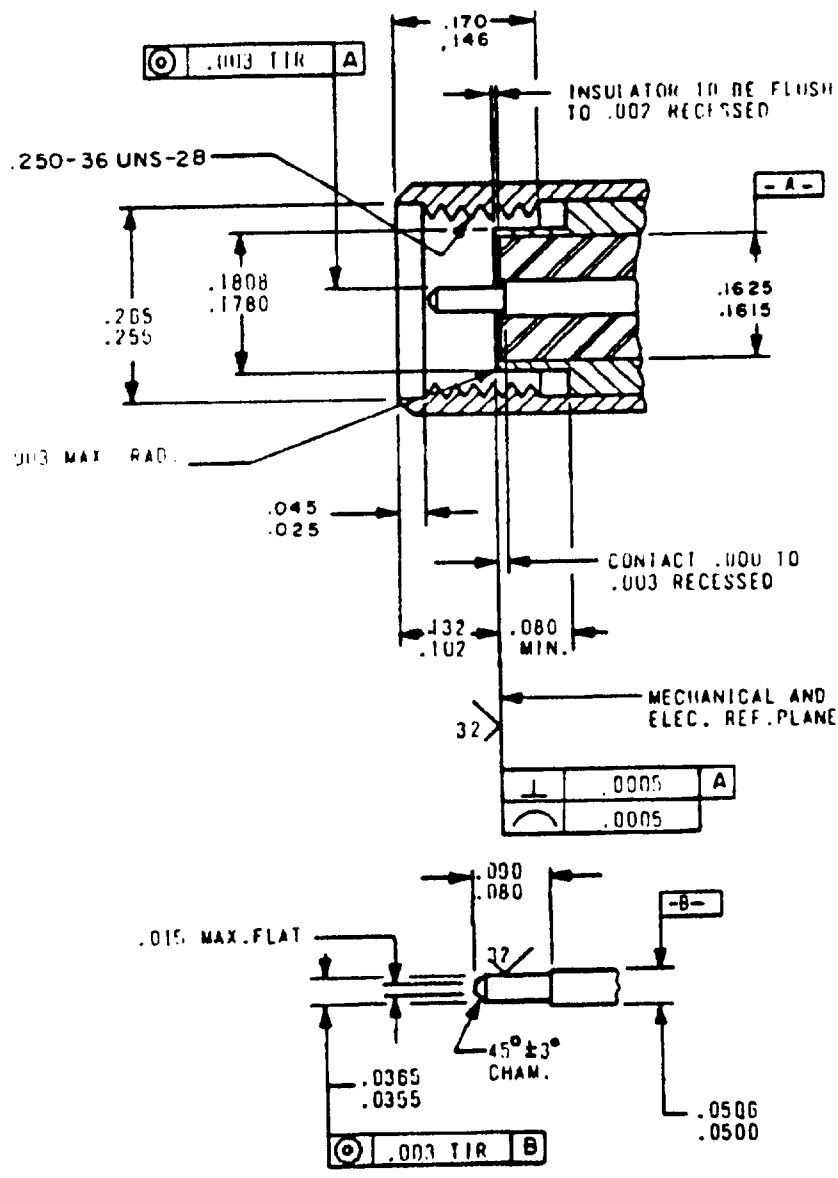

Inches	mm
.0005	0.01
.002	0.05
.003	0.08
.015	0.38
.025	0.64
.0355	0.90
.0365	0.93
.045	1.14
.0500	1.27
.0506	1.29
.080	2.03
.090	2.29
.102	2.59
.132	3.35
.146	3.71
.1615	4.10
.1625	4.13
.170	4.32
.1780	4.52
.1808	4.59
.250	6.35
.255	6.48
.265	6.73

DETAIL OF INNER CONTACT

FIGURE 405-1. Interface, test connector, series SMA, pin contact.