

INCH-POUND

MIL-STD-348B
w/CHANGE 2
19 February 2016
SUPERSEDING
MIL-STD-348B
w/CHANGE 1
6 March 2015

DEPARTMENT OF DEFENSE

INTERFACE STANDARD

RADIO FREQUENCY CONNECTOR INTERFACES FOR

MIL-DTL-3643, MIL-DTL-3650, MIL-DTL-3655, MIL-DTL-25516,
MIL-PRF-31031, MIL-PRF-39012, MIL-PRF-49142, MIL-PRF-55339, MIL-DTL-83517



AMSC N/A

FSC 5935



MIL-STD-348B
w/CHANGE 2

FORWARD

1. This Defense standard is approved for use by all Departments and Agencies of the Department of Defense (DoD).
2. Comments, suggestions, or questions on this document should be addressed to: DLA Land and Maritime, ATTN: VAI, P.O. Box 3990, Columbus, Ohio 43218-3990 or by email to RFConnectors@dsc.dla.mil. Since contact information can change, you may want to verify the currency of this address information using the ASSIST Online database at <https://assist.dla.mil>.

MIL-STD-348B
w/CHANGE 2

CONTENTS

	<u>Page</u>
1. SCOPE	1
1.1 Scope	1
1.2 Purpose	1
2. APPLICABLE DOCUMENTS	1
2.1 General	1
2.2 Government documents	1
2.2.1 Specifications, standards and handbooks	1
2.3 Order of precedence	3
3. DEFINITIONS	3
3.1 Acquisition Management System Control (AMSC)	3
3.2 Acquisition Streaming and Standardization Information System	3
3.3 Department of Defense (DoD) Standard	3
3.4 Inch-pound document	4
3.5 Interface standard	4
4. GENERAL REQUIREMENTS	4
5. REQUIREMENTS	4
5.1 Gauge tests	4
5.2 Marking	4
5.3 Drawing notes	4
5.4 Change effectivity	4
5.5 Disposition of stock	5
6. NOTES	5
6.1 Intended use	5
6.2 Acquisition requirements	5
6.3 Patent notice	5
6.4 Subject term (key word) listing	5
6.5 Changes from previous issue	5

MIL-STD-348B
 w/CHANGE 2

FIGURES

<u>FIGURE NUMBER</u>	<u>PAGE</u>
101-1. Interface, series TWTNC, coupling nut	7
101-2. Interface, series TWTNC, no coupling nut	9
102-1. Interface, series TWBNC, with coupling nut	11
102-2. Interface, series TWBNC, coupling nut	13
102-3. Interface, series TWBNC, without coupling nut	14
103-1. Interface, series TWSMC, with coupling nut	16
103-2. Interface, series TWSMC, without coupling nut	18
104-1. Interface, series TWSMB, with coupling mechanism	20
104-2. Interface, series TWSMB, without coupling mechanism	22
201-1. Interface, series TRB, pin contact	25
201-2. Interface, series TRB, socket contact	27
202-1. Interface, series TRT, pin contact	29
202-2. Interface, series TRT, socket contact	31
301-1. Interface, series BNC, pin contact	34
301-2. Interface, series BNC, socket contact	36
302-1. Interface, series C, pin contact	38
302-2. Interface, series C, socket contact	40
303-1. Interface, series MHV, pin contact	42
303-2. Interface, series MHV, socket contact	44
304-1. Interface, series N, pin contact	46
304-2. Interface, series N, socket contact	48
305-1. Interface, series QL, pin contact	50
305-2. Interface, series QL, socket contact	51
306-1. Interface, series QM, pin contact	53
306-2. Interface, series QM, socket contact	54
307-1. Interface, series QNC, pin contact	56
307-2. Interface, series QNC, socket contact	58
308-1. Interface, series QSC, pin contact	60
308-2. Interface, series QSC, socket contact	62
309-1. Interface, series SC, pin contact	64
309-2. Interface, series SC, socket contact	66
310-1. Interface, series SMA, pin contact	68
310-2. Interface, series SMA, socket contact	70
310-3. Interface, series SMA, no contact	72
310-4. Interface, series SMA, .036 contact	73
311-1. Interface, series SMB, pin contact	74
311-2. Interface, series SMB, socket contact	75
312-1. Interface, series SMC, pin contact	77
312-2. Interface, series SMC, socket contact	79
313-1. Interface, series TNC, pin contact	81
313-2. Interface, series TNC, socket contact	83
313-3. Interface, series TNCA, pin contact, air interface	85
313-4. Interface, series TNCA, socket contact, air interface	87
314-1. Interface, series SHV, pin contact	89
314-2. Interface, series SHV, socket contact	91

MIL-STD-348B
 w/CHANGE 2

FIGURES

<u>FIGURE NUMBER</u>	<u>PAGE</u>
315-1. Interface, series LC, pin contact	93
315-2. Interface, series LC, socket contact, full dielectric	94
315-3. Interface, series LC, pin contact (TBD)	96
315-4. Interface, series LC, socket contact.	97
315-5. Interface, series LC, pin contact (TBD)	99
315-6. Interface, series LC, socket contact	100
316-1. Interface, coaxial, pin contact, environment resistant	102
316-2. Interface, coaxial, socket contact, environment resistant	103
316-3. Interface, coaxial, socket, contact, environment resistant	104
316-4. Interface, coaxial, pin, contact, environment resistant	105
317-1. Interface, series HN, pin contact	106
317-2. Interface, series HN, socket contact	108
318-1. Interface, series LT, without contact	110
318-2. Interface, series LT, socket contact	112
319-1. Interface, series SSMA, pin contact	114
319-2. Interface, series SSMA, socket contact	115
320-1. Interface, series SSMB, pin contact	116
320-2. Interface, series SSMB, socket contact	118
321-1. Interface, series BMA, pin contact	119
321-2. Interface, series BMA, socket contact	120
322-1. Interface, series BMB, pin contact	121
322-2. Interface, series BMB, socket contact	123
323-1. Interface, series SMK, pin contact	125
323-2. Interface, series SMK, socket contact	126
324-1. Interface, series 2.4 mm, pin contact	128
324-2. Interface, series 2.4 mm, socket contact	130
324-3. Interface, series 2.4 mm, without contact	132
325-1. Interface, series BMZ, pin contact	133
325-2. Interface, series BMZ, socket contact	135
326-1. Interface, series SMP, socket contact (uncabled connector)	137
326-1a. Interface, series SMP, socket contact (cabled connector)	138
326-2. Interface, series SMP, pin contact, full detent	139
326-3. Interface, series SMP, pin contact, limited detent	141
326-4. Interface, series SMP, pin contact, smooth bore	143
326-5. Interface, series SMP, pin contact, catchers mit	145
327-1. Interface, series DBA, pin contact	147
327-2. Interface, series DBA, socket contact	149
328-1. Interface, series SMPM, socket contact	151
328-2. Interface, series SMPM, pin contact, full detent interface	152
328-3. Interface, series SMPM, pin contact, smooth bore interface	153
329-1. Interface, series TK, pin contact, slotted outer conductor	154
329-1a. Interface, series TK, pin contact, unslotted outer conductor	155
329-2. Interface, series TK, socket contact	157
330-1. Interface, series BNC, socket contact, 75 ohm	158
330-2. Interface, series BNC, pin contact, 75 ohm	160
331-1. Interface, series N, socket contact, 75 ohm	162
331-2. Interface, series N, pin contact, 75 ohm	163

MIL-STD-348B
w/CHANGE 2

FIGURES

<u>FIGURE NUMBER</u>		<u>PAGE</u>
332-1.	Interface, series TNC, socket contact, 75 ohm	164
332-2.	Interface, series TNC, pin contact, 75 ohm	165
401-1.	Interface, test connector, series C, pin contact	167
401-2.	Interface, test connector, series C, socket contact	169
401-3.	Interface, mated test connector, series C	171
402-1.	Interface, test connector, series N, pin contact	172
402-2.	Interface, test connector, series N, socket contact	174
402-3.	Interface, mated test connector, series N	176
403-1.	Interface, test connector, series SC, pin contact	177
403-2.	Interface, test connector, series SC, socket contact	179
403-3.	Interface, mated test connector, series SC	181
404-1.	Interface, test connector, series BNC, pin contact	182
404-2.	Interface, test connector, series BNC, socket contact	184
404-3.	Interface, mated test connector, series BNC	186
405-1.	Interface, test connector, series SMA, pin contact	187
405-2.	Interface, test connector, series SMA, socket contact	189
405-3.	Interface, mated test connector, series SMA	191
406-1.	Interface, test connector, series TNC, pin contact	192
406-2.	Interface, test connector, series TNC, socket contact	194
406-3.	Interface, mated test connector, series TNC	196
407-1.	Interface, test connector, series SMB, pin contact	197
407-2.	Interface, test connector, series SMB, socket contact	199
407-3.	Interface, mated test connector, series SMB	201
408-1.	Interface, test connector, series SMC, pin contact	202
408-2.	Interface, test connector, series SMC, socket contact	204
408-3.	Interface, mated test connector, series SMC	206
409-1.	Interface, test connector, series QNC, pin contact	207
409-2.	Interface, test connector, series QNC, socket contact	209
409-3.	Gap of mated standard test connector, series QNC	211
410-1.	Interface, test connector, series QSC, pin contact	212
410-2.	Interface, test connector, series QSC, socket contact	214
410-3.	Gap of mated standard test connector, series QSC	216

MIL-STD-348B
w/CHANGE 2

1. SCOPE

1.1 Scope. This standard specifies the dimensional requirements for radio frequency connector interfaces referenced in MIL-DTL-3643, MIL-DTL-3650, MIL-STD-3655, MIL-DTL-25516, MIL-PRF-31031, MIL-PRF-39012, MIL-PRF-49142, MIL-PRF-55339 and MIL-DTL-83517.

1.2 Purpose. The purpose of this standard is to standardize Radio Frequency connector interfaces and to ensure the inclusion of essential design requirements.

2. APPLICABLE DOCUMENTS

2.1 General. The documents listed in this section are specified in sections 3 and 4 of this standard. This section does not include documents cited in other sections of this standard or recommended for additional information or as examples. While every effort has been made to ensure the completeness of this list, document users are cautioned that they must meet all specified requirements of documents cited in sections 3 and 4 of this standard, whether or not they are listed.

2.2 Government documents.

2.2.1 Specifications, standards and handbooks. The following specifications, standards and handbooks form a part of this document to the extent specified herein. Unless otherwise specified, the issues of these documents are those cited in the solicitation or contract.

DEPARTMENT OF DEFENSE SPECIFICATIONS

MIL-DTL-3643	-	Connectors, Coaxial, Radio Frequency, Series HN, and Associated Fittings, General Specification For
MIL-DTL-3650	-	Connectors, Coaxial, Radio Frequency, Series LC
MIL-DTL-3655	-	Connector, Plug and Receptacle, Electrical (Coaxial, Series Twin), and Associated Fittings, General Specification For
MIL-DTL-3655/13	-	Connector, Receptacle, Electrical, Class I (Coaxial, Series Twin, TWTNC, Jam Nut Mounted)
MIL-DTL-3655/14	-	Connector, Plug, Electrical, Class I (Coaxial, Series Twin, TWTNC)
MIL-DTL-3655/15	-	Connector, Plug, Electrical, Class I (Coaxial, Series Twin, TWBNC)
MIL-DTL-3655/16	-	Connector, Receptacle, Electrical, Class I (Coaxial, Series Twin, TWBNC)
MIL-DTL-3655/17	-	Connector, Plug, Electrical, Class I (Coaxial, Series Twin, TWTNC, Right Angle)
MIL-DTL-25516	-	Connectors, Electrical, Miniature, Coaxial, Environment Resistant Type, General Specification For
MIL-PRF-31031	-	Connectors, Electrical, Plugs and Receptacles, Coaxial, Radio Frequency, High Reliability, For Flexible and Semirigid Cables, General Specification For

MIL-STD-348B
w/CHANGE 2

- MIL-PRF-39012 - Connectors, Coaxial, Radio Frequency, General Specification For
- MIL-PRF-39012/1 - Connectors, Plug, Electrical, Coaxial, Radio Frequency, (Series N (Cabled), Pin Contact, Class 2)
- MIL-PRF-39012/2 - Connectors, Plugs and Receptacles, Electrical, Coaxial, Radio Frequency, (Series N (Cabled), Flange Mounted, Socket Contact, Class 2)
- MIL-PRF-39012/6 - Connectors, Plug, Electrical, Coaxial, Radio Frequency, (Series C, (Cabled), Male, Class 2)
- MIL-PRF-39012/7 - Connectors, Plug, Electrical, Coaxial, Radio Frequency, (Series C, (Cabled), Male, Class 2)
- MIL-PRF-39012/16 - Connectors, Plugs, Electrical, Coaxial Radio Frequency, (Series BNC (Cabled), Pin Contact, Class 2)
- MIL-PRF-39012/17 - Connectors, Plugs, Electrical, Coaxial, Radio Frequency, (Series BNC, (Cabled), Socket Contact, Class 2)
- MIL-PRF-39012/26 - Connectors, Plugs, Electrical, Coaxial Radio Frequency, (Series TNC (Cabled), Pin Contact, Class 2)
- MIL-PRF-39012/28 - Connectors, Receptacles, Electrical, Coaxial, Radio Frequency, (Series TNC, (Cabled), Socket Contact, Jam Nut Mounted, Class 2)
- MIL-PRF-39012/40 - Connectors, Receptacle, Electrical, Coaxial, Radio Frequency (Series SC (Cabled), Socket Contact, Jam Nut, Rear Mounted, Class 2)
- MIL-PRF-39012/67 - Connectors, Plugs, Electrical, Coaxial, Radio Frequency, Series SMB (Cabled, Socket Contact, Class 2)
- MIL-PRF-39012/68 - Connectors, Plugs, Electrical, Coaxial, Radio Frequency, Series SMB (Cabled, Pin Contact, Class 2)
- MIL-PRF-39012/73 - Connectors, Plugs, Electrical, Coaxial, Radio Frequency, Series SMC (Cabled, Socket Contact, Class 2)
- MIL-PRF-39012/74 - Connectors, Plugs, Electrical, Coaxial, Radio Frequency, Series SMC (Cabled, Pin Contact, Class 2)
- MIL-PRF-39012/92 - Connectors, Plug, Electrical, Coaxial, Radio Frequency, Series SMA (Cabled, Class 2, Without Contact, .141 Semirigid Cable)
- MIL-PRF-39012/100 - Connectors, Plug, Electrical, Coaxial, Radio Frequency, High Voltage (Series MHV (Cabled), Pin Contact, Class 2)
- MIL-PRF-49142 - Connector, Triaxial, Radio Frequency, General Specification For

MIL-STD-348B
w/CHANGE 2

- MIL-PRF-55339 - Adapters, Connectors, Coaxial, Radio Frequency,(Between Series and Within Series), General Specification For
- MIL-DTL-83517 - Connector, Coaxial, Radio Frequency For Coaxial, Strip or Microstrip Transmission Line, General Specification For

DEPARTMENT OF DEFENSE STANDARD

- MIL-STD-1373 - Screw-Thread, Modified, 60 Degree Stub, Double.

(Copies of these documents are available online at <http://quicksearch.dla.mil/> .

2.3 Order of precedence. In the event of a conflict between the text of this document and the references cited herein, the text of this document takes precedence. Nothing in this document, however, supersedes applicable laws and regulations unless a specific exemption has been obtained.

3. DEFINITIONS

3.1 Acquisition Management Systems Control (AMSC) Number. A control number assigned by the cognizant data management approval authority listed in SD-1, which indicates that a data item description (DID) or a defense specification or standard that cites DIDs has been cleared for use by the DoD.

3.2 Acquisition Streamlining and Standardization Information System (ASSIST). The official database containing information about standardization documents used in the DoD. ASSIST also provides electronic access to government documents included in the database over the Internet. ASSIST can be accessed at <http://quicksearch.dla.mil/> .

3.3 Department of Defense (DoD) Standard. A standard used to satisfy primarily multiple, military-unique applications. There are five types of DoD standards: interface standards, design criteria standards, manufacturing process standards, standard practices, and test method standards.

MIL-STD-348B
 w/CHANGE 2

3.4 Inch-pound document. A document having measurement requirements given in rounded, rational, inch-pound units. The magnitudes are meaningful and practical (for example, 1 ounce, not 28.3495 grams). Inch-pound documents are developed for items to interface or operate with other inch-pound items. NOTE: Documents in which magnitudes expressed in metric units (as a result of mathematical conversion from rounded, rational, inch-pound units) are given first as preferred units with the rounded, rational inch-pound units given in parentheses or in a non-preferred position are still inch-pound documents.

3.5 Interface standard. A standard that specifies the physical, functional, or military operational environment interface characteristics of systems, subsystems, equipment, assemblies, components, items, or parts to permit interchangeability, interconnection, interoperability, compatibility, or communications.

4. GENERAL REQUIREMENTS. The interfaces specified herein shall work in conjunction with the following associated defense specifications to achieve the specified performance required.

MIL-DTL-3643, MIL-DTL-3650, MIL-DTL-3655, MIL-DTL-26616, MIL-PRF-31031,
 MIL-PRF-39012, MIL-PRF-49142, MIL-PRF-55339, MIL-DTL-83517 and MIL-STD-1373.

5. REQUIREMENTS

5.1 Gauge tests. Applicable gauge tests shall be as specified in the associated connector specification sheet.

5.2 Marking. Not applicable.

5.3 Drawing notes. Unless otherwise specified, the following information is applicable to all figures of this defense standard.

- a. Dimensions are in inches unless a specific metric interface is specified.
- b. Metric equivalents are given for information only.
- c. All undimensioned, pictorial configurations are for reference purposes only.
- d. Applicable to section 400 only. The construction, material, and finish of the standard socket connector shall result in satisfactory electrical and mechanical performance and provide the following minimum life cycles when mated with the same series pin standard test connector.

<u>Series</u>	<u>Life cycles</u>
C, N, SC, TNC	10,000
BNC	5,000
SMA, SMB, SMC	2,000

- e. Applicable to section 400 only. Dimensions shown are for the standard test connector only.

5.4 Change effectivity. Unless otherwise specified in the interface figure, all changes from the preceding issue of MIL-STD-348 will become effective 12 months from the date of this standard.

MIL-STD-348B
w/CHANGE 2

5.5 Disposition of stock. Unless otherwise specified in the interface figure, qualified manufacturers and their selling agents or distributors may ship from stock connectors which were manufactured in accordance with the preceding issue of MIL-STD-348 for a period of 30 months from the date of this standard.

6. NOTES

(This section contains information of a general or explanatory nature that may be helpful, but is not mandatory.)

6.1 Intended use. This standard is intended for use by all manufacturers of connectors and components utilizing connector interfaces. The interfaces detailed within this document have been coordinated and accepted by all military services and are deemed United States standards for radio frequency connector interfaces.

6.2 Acquisition requirements. Acquisition documents should specify the following:
a. Title, number, and date of this specification.

6.3 Patent notice. The Government has a royalty-free license under the following listed patents for the benefit of manufacturers of the item either for the Government or for use in equipment to be delivered to the Government. U.S. patent number 4,426,127 applies to the series BMA, 4,358,174 applies to series BMB interfaces.

U.S. patent number 4,426,127

U.S. patent number 4,358,174

6.4 Subject term (key word) listing.

RF
Interconnection device

6.5 Changes from previous issue. The margins of this specification are marked with vertical lines to indicate where changes from the previous issue were made. This was done as a convenience only and the Government assumes no liability whatsoever for any inaccuracies in these notations. Bidders and contractors are cautioned to evaluate the requirements of this document based on the entire content irrespective of the marginal notations and relationship to the previous issue.

MIL-STD-348B
w/CHANGE 2

SECTION 100

Interface Dimensions for MIL-DTL-3655

Section 101	Series TWTNC
Section 102	Series TWBNC
Section 103	Series TWSMC
Section 104	Series TWSMB

MIL-STD-348B
 w/CHANGE 2

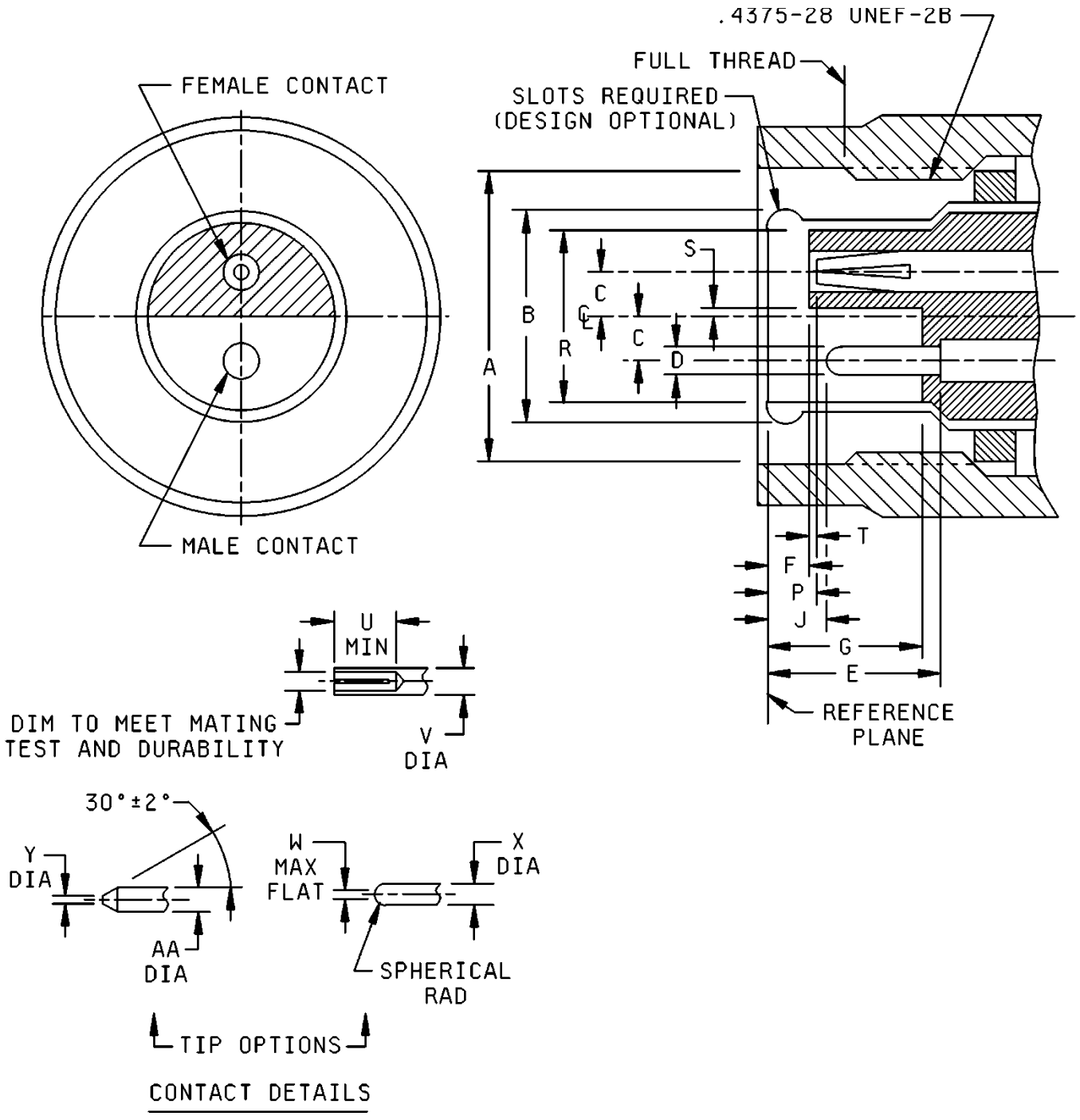

FIGURE 101-1. Interface, series TWTNC, coupling nut.

**MIL-STD-348B
 w/CHANGE 2**

Dimension Ltr.	Inches (mm)	
	Minimum	Maximum
A	.440 (11.18)	-----
B	Mating test	
C	.062 (1.57)	.064 (1.63)
D	.037 (0.94)	.039 (0.99)
E	.228 (5.79)	.260 (6.60)
F	.028 (0.71)	.042 (1.07)
G	.206 (5.23)	.228 (5.79)
J	.035 (0.89)	.065 (1.65)
P	.032 (0.81)	.062 (1.57)
R	.264 (6.71)	-----
S	.001 (0.03)	.004 (0.10)
T	.000 (0.00)	-----
U	.180 (4.57)	-----
V	.061 (1.55)	.064 (1.63)
W	-----	.015 (0.38)
X	.037 (0.94)	.039 (0.99)
Y	.010 (0.25)	.015 (0.38)
AA	.037 (0.94)	.039 (0.99)

NOTES:

1. Three holes equally spaced, .027 (0.69 mm) minimum diameter for safety wiring. Location on coupling nut optional.
2. This interface shall meet the gauge requirements as specified in MIL-DTL-3655/14.
3. Dimensions are in inches.
4. Metric equivalents are for information only.

FIGURE 101-1. Interface, series TWTNC, coupling nut – Continued.

MIL-STD-348B
 w/CHANGE 2

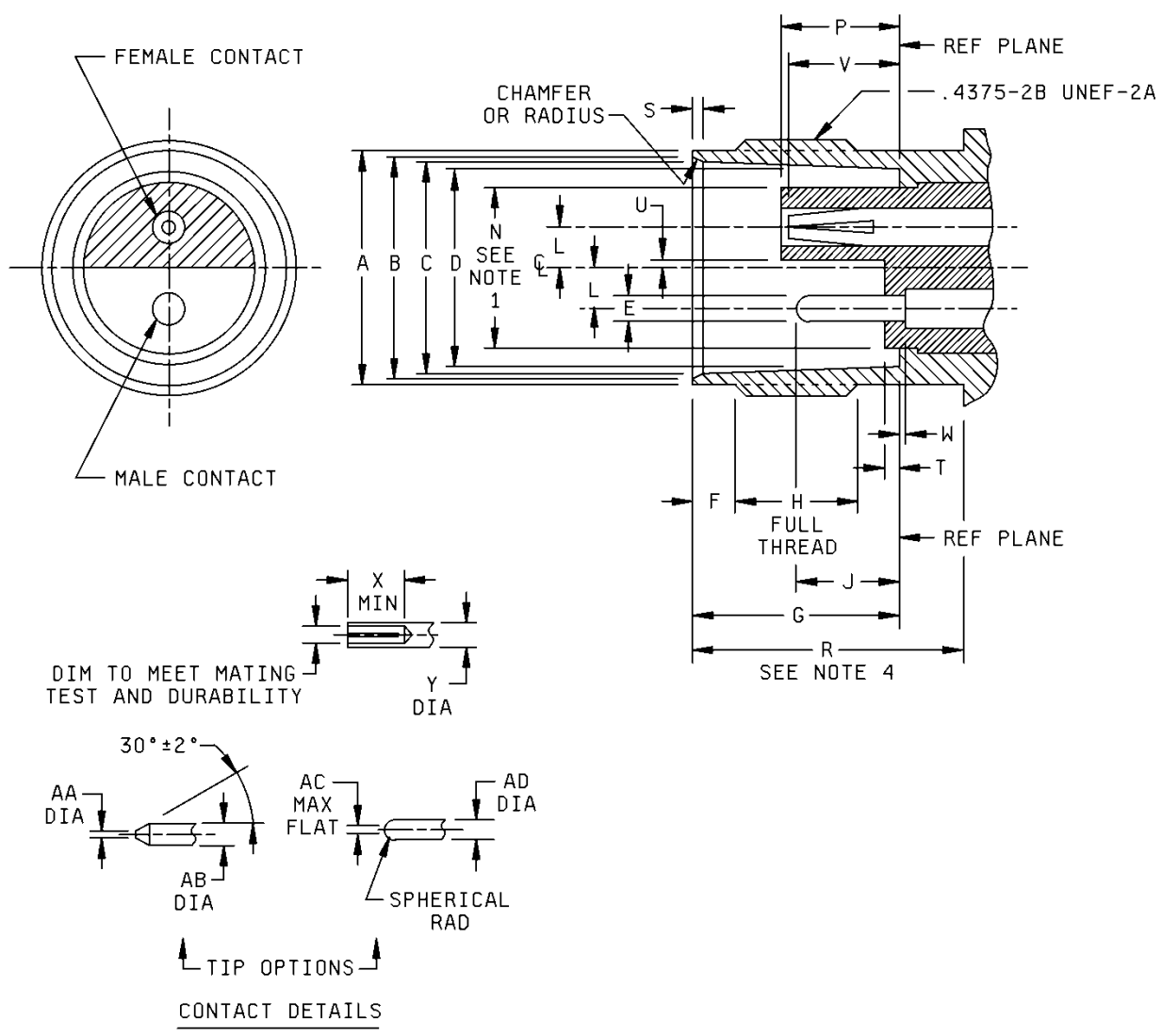

FIGURE 101-2. Interface, series TWNC, no coupling nut.

MIL-STD-348B
 w/CHANGE 2

Dimension Ltr.	Inches (mm)	
	Minimum	Maximum
A	.378 (9.60)	.381 (9.68)
B	.345 (8.76)	.356 (9.04)
C	.327 (8.31)	.336 (8.53)
D	.319 (8.10)	.321 (8.15)
E	.037 (0.94)	.039 (0.99)
F	.068 (1.73)	.088 (2.24)
G	.329 (8.36)	.333 (8.46)
H	.187 (4.75)	-----
J	.171 (4.34)	.200 (5.08)
L	.062 (1.57)	.064 (1.63)
N	-----	.262 (6.65)
P	.188 (4.78)	.206 (5.23)
R	.415 (10.54)	-----
S	.015 (0.38)	.030 (0.76)
T	.000 (0.00)	.028 (0.71)
U	.001 (0.03)	.004 (0.10)
V	.170 (4.32)	.200 (5.08)
W	.000 (0.00)	.040 (1.02)
X	.180 (4.57)	-----
Y	.061 (1.55)	.064 (1.63)
AA	.010 (0.25)	.015 (0.38)
AB	.037 (0.94)	.039 (0.99)
AC	-----	.015 (0.38)
AD	.037 (0.94)	.039 (0.99)

NOTES:

1. N dimension applies to portion of dielectric protruding beyond reference plane.
2. Contacts, insulator, and mounting flat shall be oriented within $\pm 3^\circ$ of orientation shown.
3. This interface shall meet the gauge requirements as specified in MIL-DTL-3655/13.
4. Clearance for mating connector coupling nut.
5. Dimensions are in inches.
6. Metric equivalents are for information only.

FIGURE 101-2. Interface, series TWTNC, no coupling nut – Continued.

MIL-STD-348B
 w/CHANGE 2

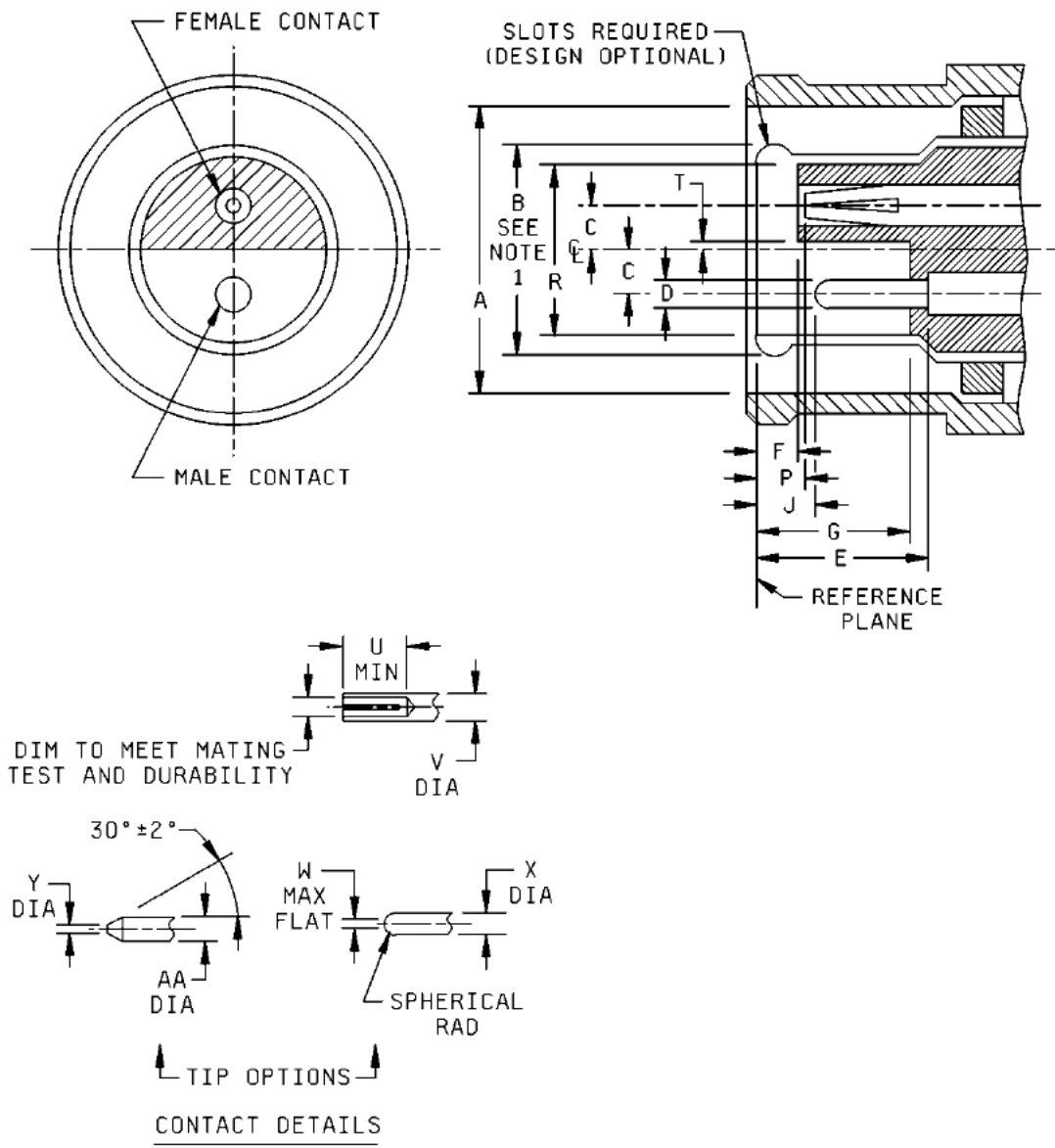

FIGURE 102-1. Interface, series TWBNC, with coupling nut.

**MIL-STD-348B
 w/CHANGE 2**

Dimension Ltr.	Inches (mm)	
	Minimum	Maximum
A	.385 (9.78)	.390 (9.91)
B	Mating test	
C	.062 (1.57)	.064 (1.63)
D	.037 (0.94)	.039 (0.99)
E	.228 (5.79)	.260 (6.60)
F	.028 (0.71)	.042 (1.07)
G	.206 (5.23)	.228 (5.79)
J	.035 (0.89)	.065 (1.65)
P	.032 (0.81)	.062 (1.57)
R	.264 (6.71)	-----
T	.001 (0.03)	.004 (0.10)
U	.180 (4.57)	-----
V	.061 (1.55)	.064 (1.63)
W	-----	.015 (0.38)
X	.037 (0.94)	.039 (0.99)
Y	.010 (0.25)	.015 (0.38)
AA	.037 (0.94)	.039 (0.99)

NOTES:

1. Flare to meet gauge test.
2. This interface shall meet the gauge requirements as specified in MIL-DTL-3655/15.
3. Dimensions are in inches.
4. Metric equivalents are for information only.

FIGURE 102-1. Interface, series TWBNC, with coupling nut – Continued.

MIL-STD-348B
 w/CHANGE 2

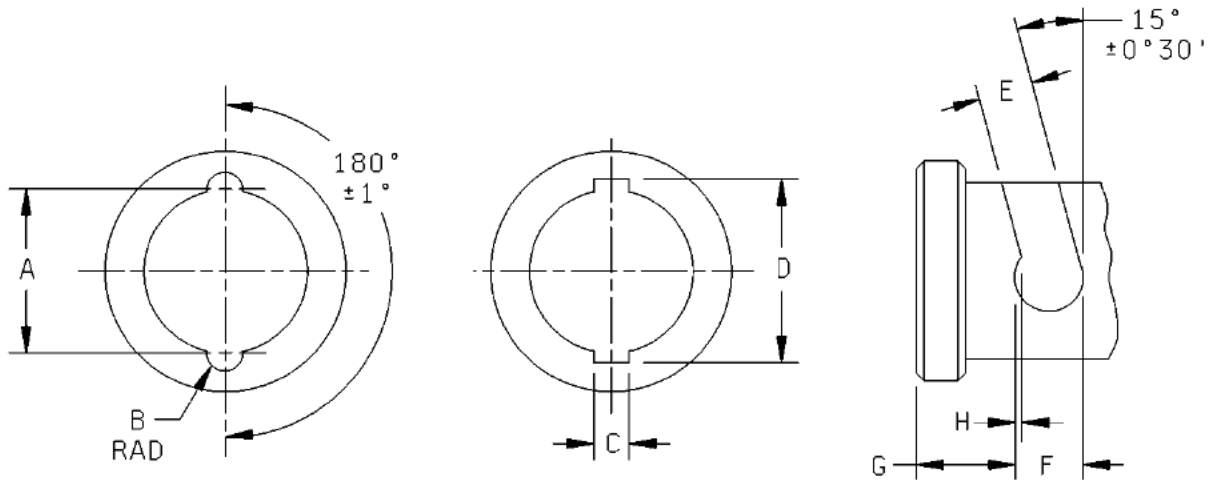

Alternate design

Dimension Ltr.	Inches (mm)	
	Minimum	Maximum
A	.394 (10.01)	.400 (10.16)
B	.045 (1.14)	.049 (1.24)
C	.091 (2.31)	.097 (2.46)
D	.463 (11.76)	.473 (12.01)
E	.091 (2.31)	.097 (2.46)
F	.124 (3.15)	-----
G	.180 (4.57)	.184 (4.67)
H	.018 (0.46)	.022 (0.56)

NOTES:

1. Dimensions are in inches.
2. Metric equivalents are for information only.

FIGURE 102-2. Interface, series TWBNC, coupling nut.

MIL-STD-348B
 w/CHANGE 2

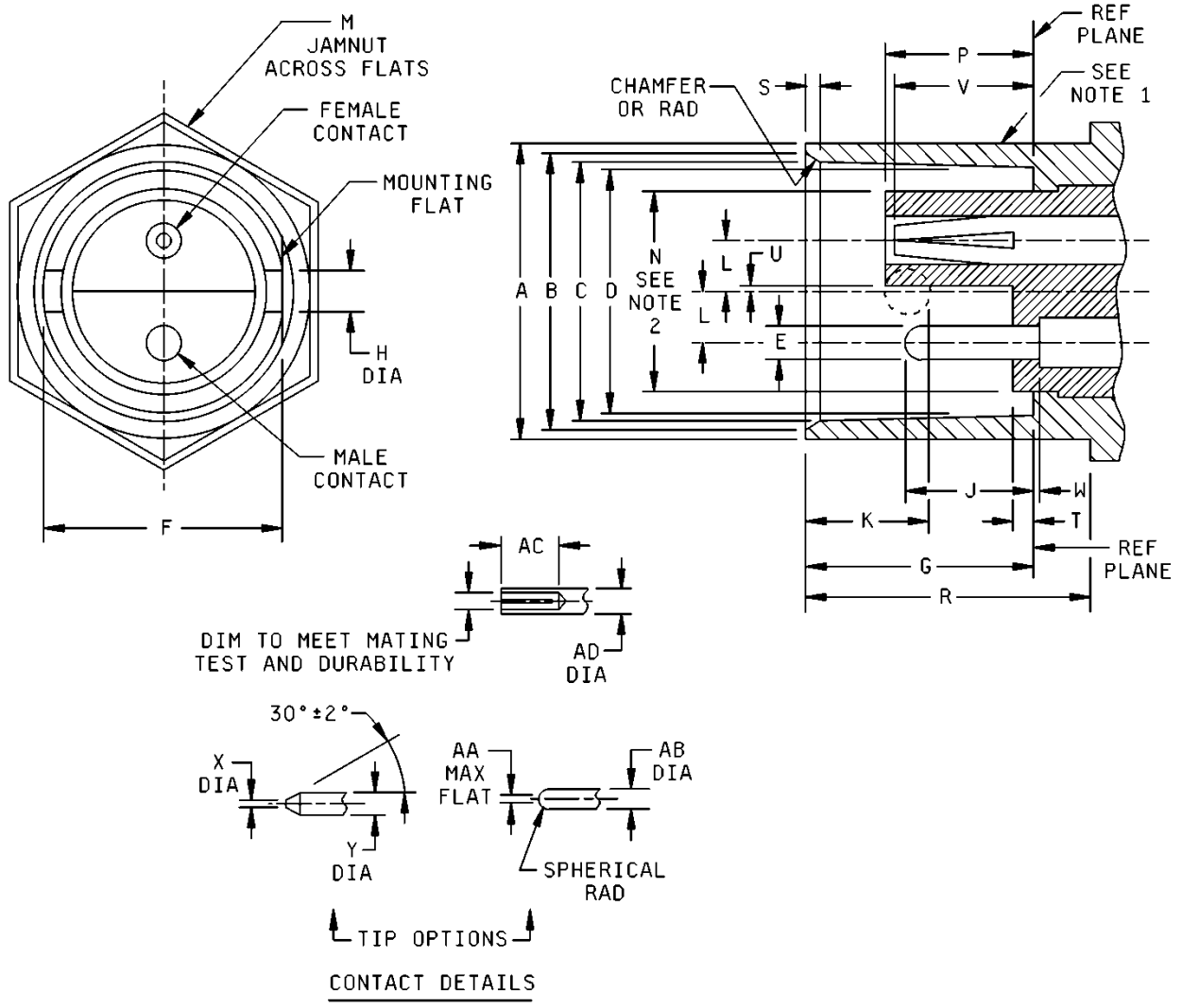

FIGURE 102-3. Interface, series TWBNC, without coupling nut.

MIL-STD-348B
 w/CHANGE 2

Dimension Ltr.	Inches (mm)	
	Minimum	Maximum
A	.378 (9.60)	.381 (9.68)
B	.345 (8.76)	.356 (9.04)
C	.327 (8.31)	.336 (8.53)
D	.319 (8.10)	.321 (8.15)
E	.037 (0.94)	.039 (0.99)
F	.432 (10.97)	.436 (11.07)
G	.329 (8.36)	.333 (8.46)
H	.075 (1.91)	.081 (2.06)
J	.171 (4.34)	.200 (5.08)
K	.204 (5.18)	.208 (5.28)
L	.062 (1.57)	.064 (1.63)
M	.620 (15.75)	.630 (16.00)
N	-----	.262 (6.65)
P	.188 (4.78)	.206 (5.23)
R See note 6	.415 (10.54)	-----
S	.015 (0.38)	.030 (0.76)
T	0 (.00)	.028 (0.71)
U	.001 (0.03)	.004 (0.10)
V	.170 (4.32)	.200 (5.08)
W	0 (.00)	.040 (1.02)
X	.010 (0.25)	.015 (0.38)
Y	.037 (0.94)	.039 (0.99)
AA	-----	.015 (0.38)
AB	.037 (0.94)	.039 (0.99)
AC	.180 (4.57)	-----
AD	.061 (1.55)	.064 (1.62)

NOTES:

1. Concave depression .100 x .005 deep between studs permitted.
2. N dimension applies to portion of dielectric protruding beyond reference plane.
3. Bayonet studs and plane of contacts shall be within $\pm 3^\circ$ of orientation shown.
4. Contacts, insulator and mounting flat shall be oriented within $\pm 3^\circ$ of orientation shown.
5. This interface shall meet the gauge requirements as specified in MIL-DTL-3655/16.
6. Clearance for mating connector coupling nut.
7. Dimensions are in inches.
8. Metric equivalents are for information only.

FIGURE 102-3. Interface, series TWBNC, without coupling nut - Continued.

MIL-STD-348B
 w/CHANGE 2

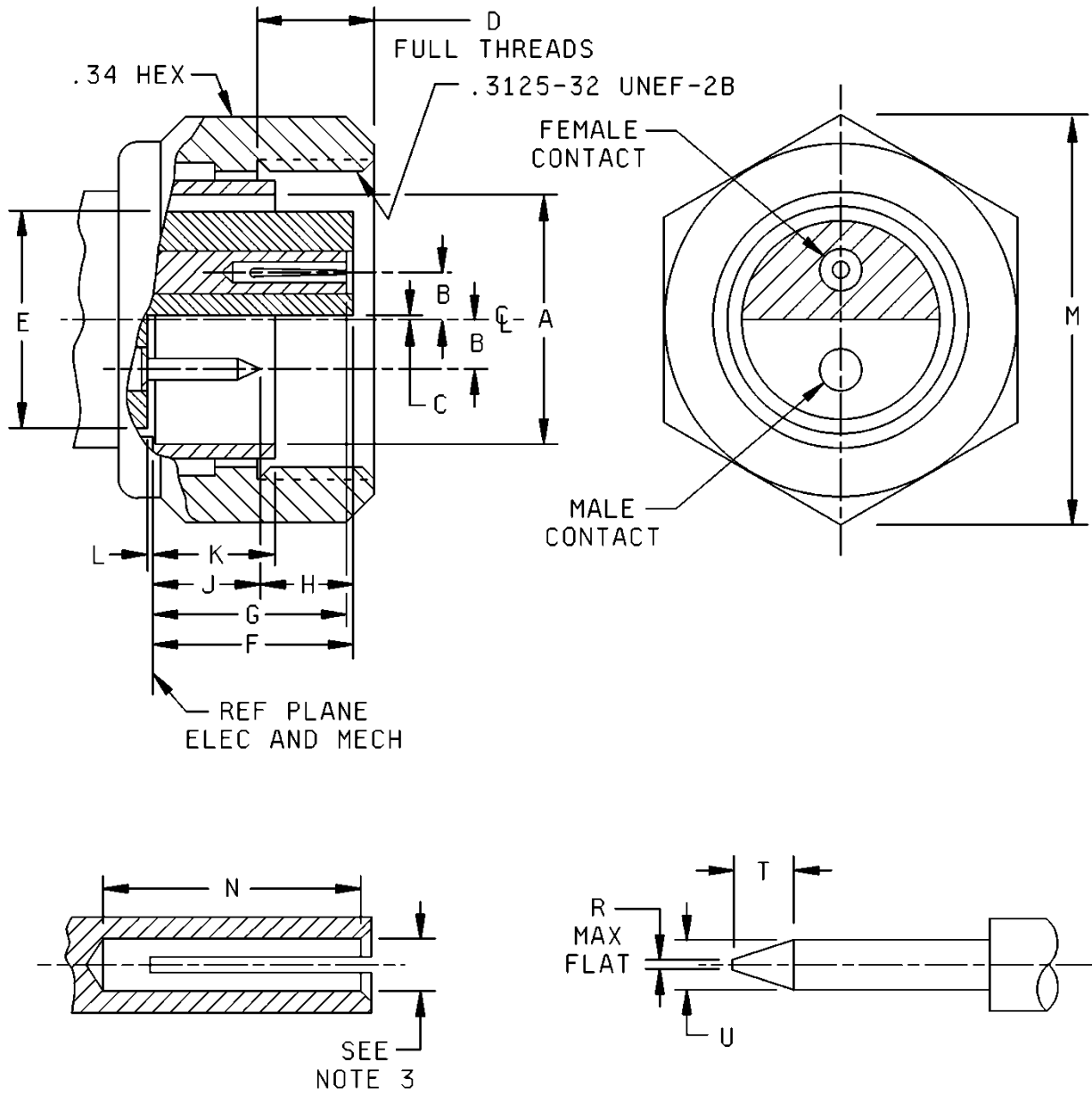

FIGURE 103-1. Interface, series TWSMC, with coupling nut.

MIL-STD-348B
 w/CHANGE 2

Dimension Ltr.	Inches (mm)	
	Minimum	Maximum
A (dia.)	.246 (6.25)	-----
B	.0465 (1.181)	.0485 (1.232)
C	.003 (0.08)	-----
D	.110 (2.79)	-----
E	-----	.209 (5.31)
F	-----	.199 (5.05)
G	-----	.199 (5.05)
H	.096 (2.44) Reference	
J	-----	.105 (2.67)
K	-----	.122 (3.10)
L	.000 (0.00)	-----
M	-----	.320 (8.13)
N	.110 (2.79)	-----
R	-----	.010 (0.25)
T	.010 (0.25)	-----
U (dia.)	.019 (0.48)	.021 (0.53)

NOTES:

1. This interface shall meet the gauge requirements as specified in MIL-DTL-3655/18.
2. Thread gauge must go .234 (5.94 mm) minimum from reference plane.
3. Dimensions to meet the mechanical and electrical performance requirements of specification when mated with pin specified herein.
4. Dimensions are in inches.
5. Metric equivalents are for information only.

FIGURE 103-1. Interface, series TWSMC, with coupling nut - Continued.

MIL-STD-348B
 w/CHANGE 2

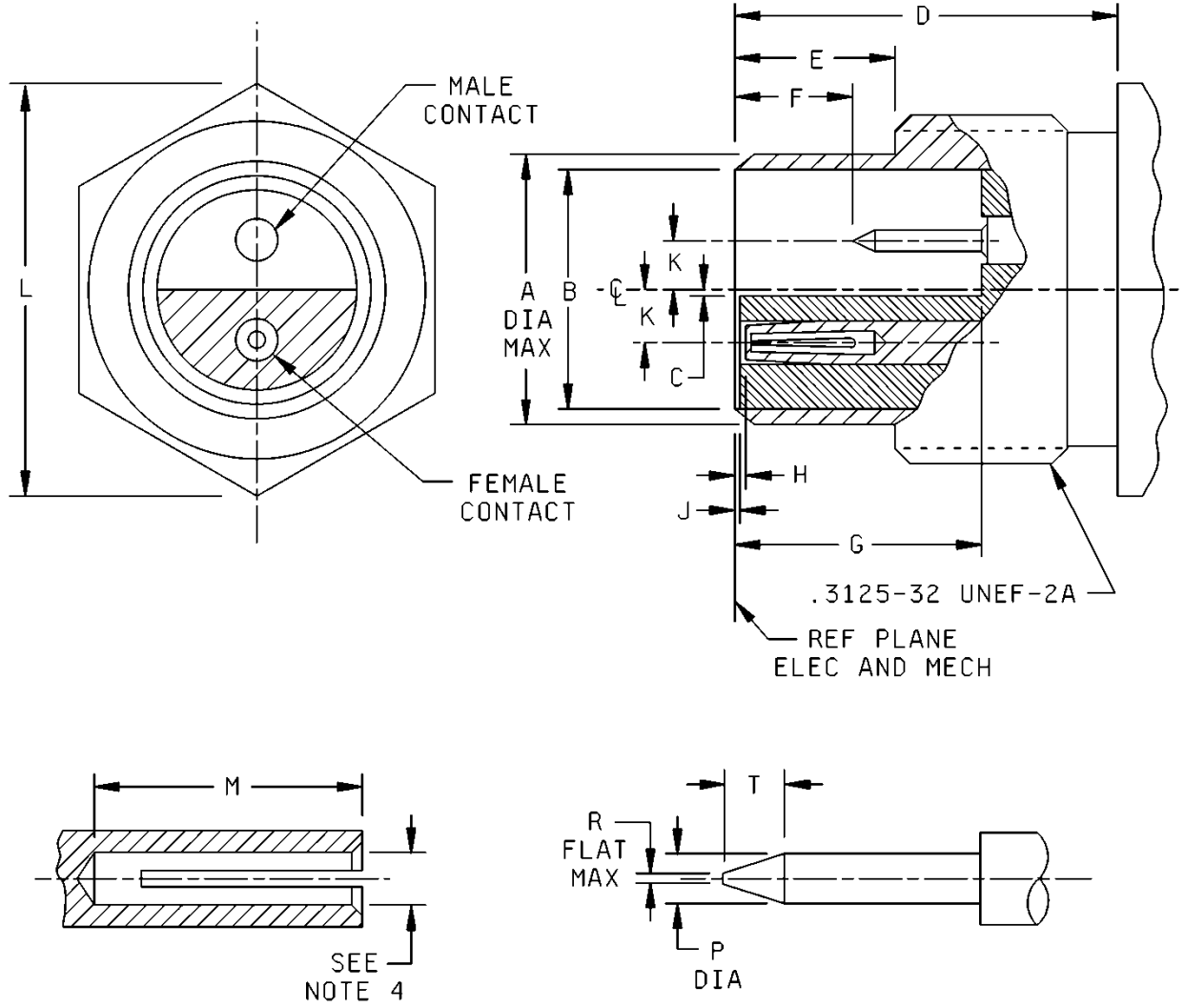

FIGURE 103-2. Interface, series TWSMC, without coupling nut.

MIL-STD-348B
 w/CHANGE 2

Dimension Ltr.	Inches (mm)	
	Minimum	Maximum
A	-----	.245 (6.22)
B	.210 (5.33)	-----
C	.003 (0.08)	-----
D See notes 2 and 3	.234 (5.94)	-----
E	.128 (3.25)	
F	.096 (2.44)	
G	.200 (5.08)	-----
H	.000 (0.00)	.015 (0.38)
J	.000 (0.00)	-----
K	.0465 (1.181)	.0485 (1.232)
L	-----	.320 (8.13)
M	.110 (2.79)	-----
P (dia.)	.019 (0.48)	.021 (0.53)
R	-----	.010 (0.25)
T	.010 (0.25)	-----

NOTES:

1. This interface shall meet mating requirements as specified in MIL-DTL-3655/19.
2. Thread gauge must go .234 (5.94 mm) minimum from reference plane.
3. Clearance for mating connector coupling nut.
4. Dimensions to meet the mechanical and electrical performance requirements when mated to pin specified herein.
5. Dimensions are in inches.
6. Metric equivalents are for information only.

FIGURE 103-2. Interface, series TWSMC, without coupling nut - Continued.

MIL-STD-348B
w/CHANGE 2

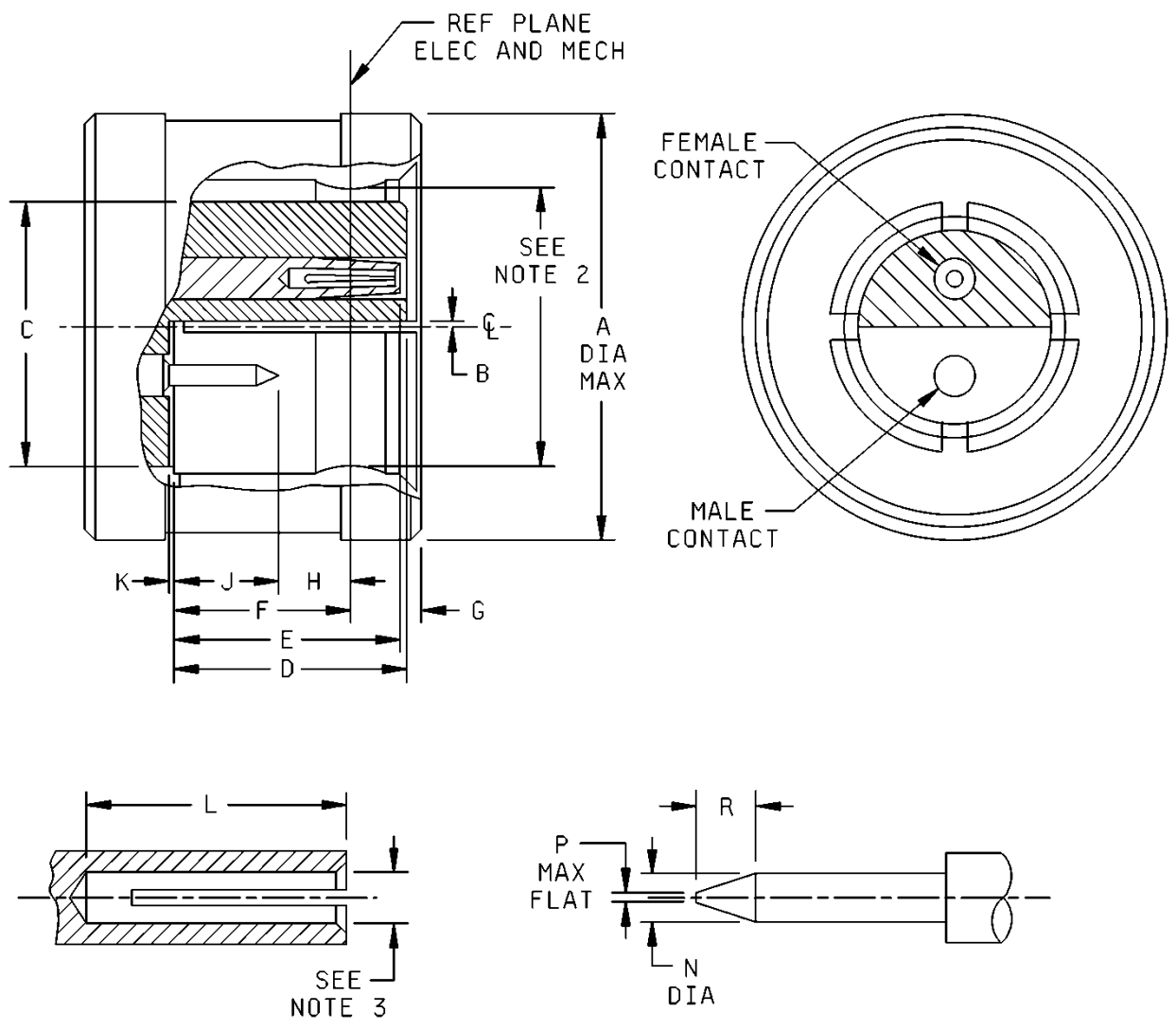

FIGURE 104-1. Interface, series TW-SMB, with coupling mechanism.

**MIL-STD-348B
 w/CHANGE 2**

Dimension Ltr.	Inches (mm)	
	Minimum	Maximum
A	-----	.370 (9.40)
B	.003 (0.08)	-----
C	-----	.209 (5.31)
D	-----	.199 (5.05)
E	-----	.199 (5.05)
F	.141 (3.58)	-----
G	-----	.064 (1.63)
H	-----	.038 (0.97)
J	-----	.105 (2.67)
K	.000 (0.00)	-----
L	.110 (2.79)	-----
N	.019 (0.48)	.021 (0.53)
P	-----	.010 (0.25)
R	.010 (0.25)	-----

NOTES:

1. This interface shall meet the gauge requirements as specified in MIL-DTL-3655/20.
2. This interface shall meet the force to engage/disengage as specified in MIL-DTL-3655/20.
3. ID to meet mating characteristics and connector durability when mated with pin specified herein.
4. Dimensions are in inches.
5. Metric equivalents are for information only.

FIGURE 104-1. Interface, series TWSMB, with coupling mechanism - Continued.

MIL-STD-348B
 w/CHANGE 2

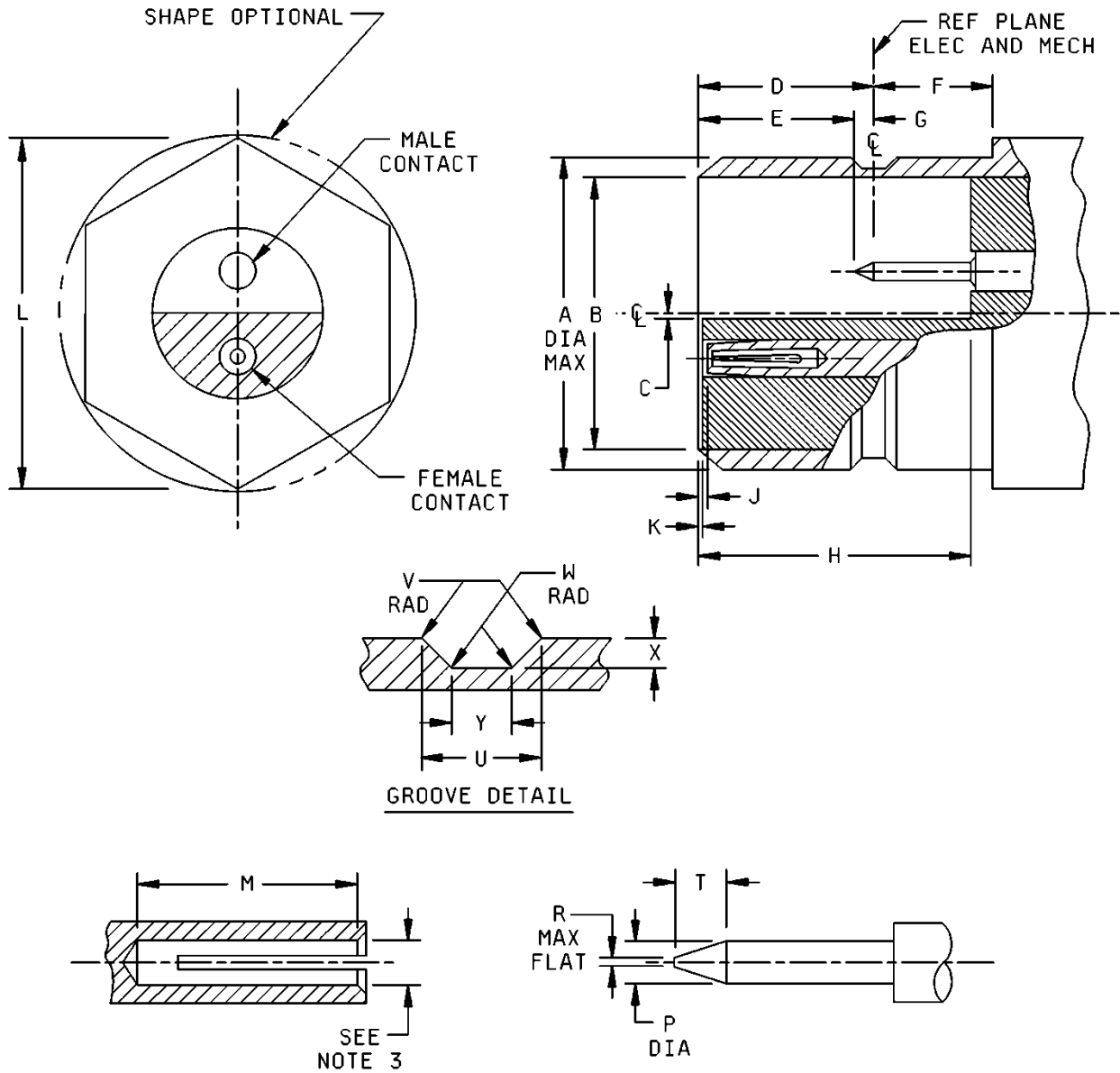

FIGURE 104-2. Interface, series TWSMB, without coupling mechanism.

**MIL-STD-348B
 w/CHANGE 2**

Dimension Ltr.	Inches (mm)	
	Minimum	Maximum
A	-----	.245 (6.22)
B	.210 (5.33)	-----
C	.003 (0.08)	-----
D	.131 (3.33)	.141 (3.58)
E	.096 (2.44)	-----
F	.065 (1.65)	-----
See note 2		
G	-----	.045 (1.14) Ref.
H	.200 (5.08)	-----
J	.000 (0.00)	.015 (0.38)
K	.000 (0.00)	-----
L	-----	.320 (8.13)
M	.110 (2.79)	-----
P	.019 (0.48)	.021 (0.53)
R	-----	.010 (0.25)
T	.010 (0.25)	-----
U	.027 (0.69)	.037 (0.94)
V	.002 (0.05)	.006 (0.15)
W	-----	.005 (0.13)
X	.006 (0.15)	.010 (0.25)
Y	.011 (0.28)	.015 (0.38)

NOTES:

1. This interface shall meet the mating requirements as specified in MIL-DTL-3655/21.
2. Clearance for mating connector coupling nut.
3. ID to meet mating characteristics and connector durability when mated with pin specified herein.
4. Dimensions are in inches.
5. Metric equivalents are for information only.

FIGURE 104-2. Interface, series TWSMB, without coupling mechanism - Continued.

MIL-STD-348B
w/CHANGE 2

SECTION 200

Interface Dimensions for MIL-DTL-49142

Section 201	Series TRB
Section 202	Series TRT

MIL-STD-348B
 w/CHANGE 2

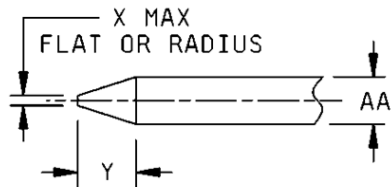
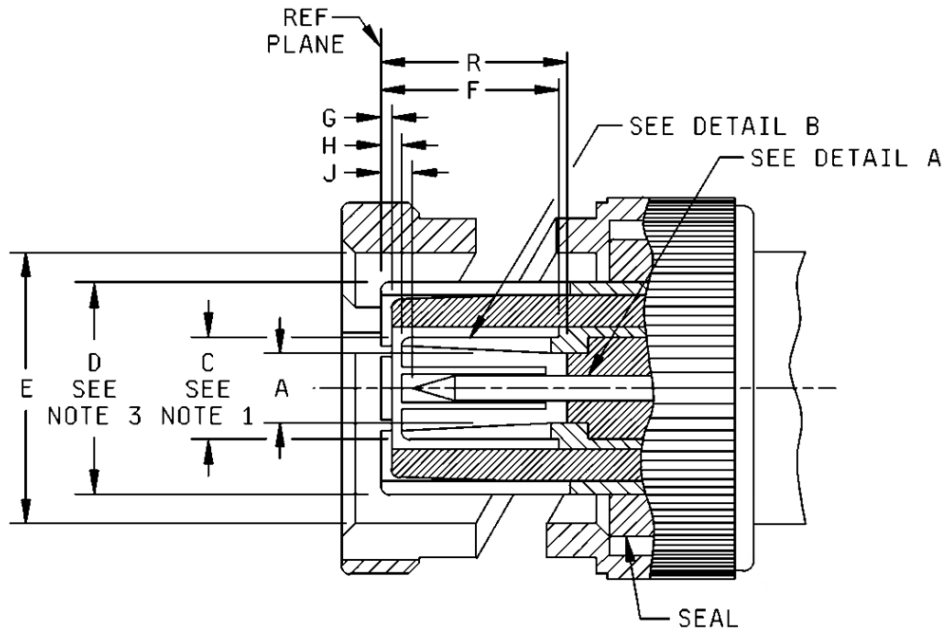

CENTER CONDUCTOR
DETAIL A

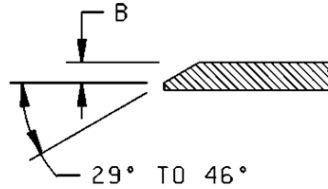

INTERMEDIATE CONDUCTOR
DETAIL B

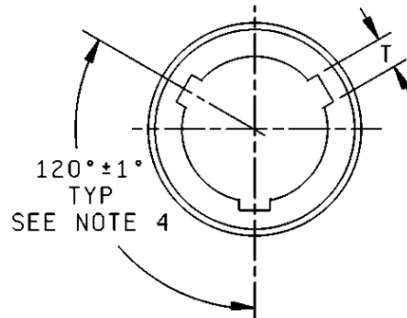
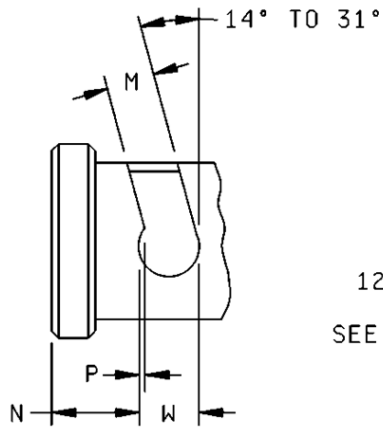

FIGURE 201-1. Interface, series TRB, pin contact.

**MIL-STD-348B
w/CHANGE 2**

Ltr.	Inches (mm)	
	Min.	Max.
A	.123 (3.12)	-----
B	.005 (0.13)	.010 (0.25)
C	See note 1	
D		
E	.385 (9.78)	.390 (9.91)
F	.213 (5.41)	.242 (6.15)
G	.001 (0.03)	-----
H	.007 (0.18)	.033 (0.84)
J	.008 (0.20)	.042 (1.07)
M	.091 (2.31)	.097 (2.46)
N	.180 (4.57)	.184 (4.67)
P	.018 (0.46)	.022 (0.56)
R	.213 (5.41)	-----
T	.091 (2.31)	.097 (2.46)
W	.124 (3.15)	-----
X	-----	.010 (0.25)
Y	.041 (1.04)	.061 (1.55)
AA	.037 (0.94)	.039 (0.99)

NOTES:

1. Flared to meet mating characteristic test.
2. Metric equivalents are given in parentheses or tabulated.
3. This interface shall meet the gauge requirements of MIL-PRF-49142.
4. Standard polarization, see MIL-PRF-49142 for other options.
5. Dimensions are in inches.
6. Metric equivalents are for information only.

FIGURE 201-1. Interface, series TRB, pin contact - Continued.

MIL-STD-348B
 w/CHANGE 2

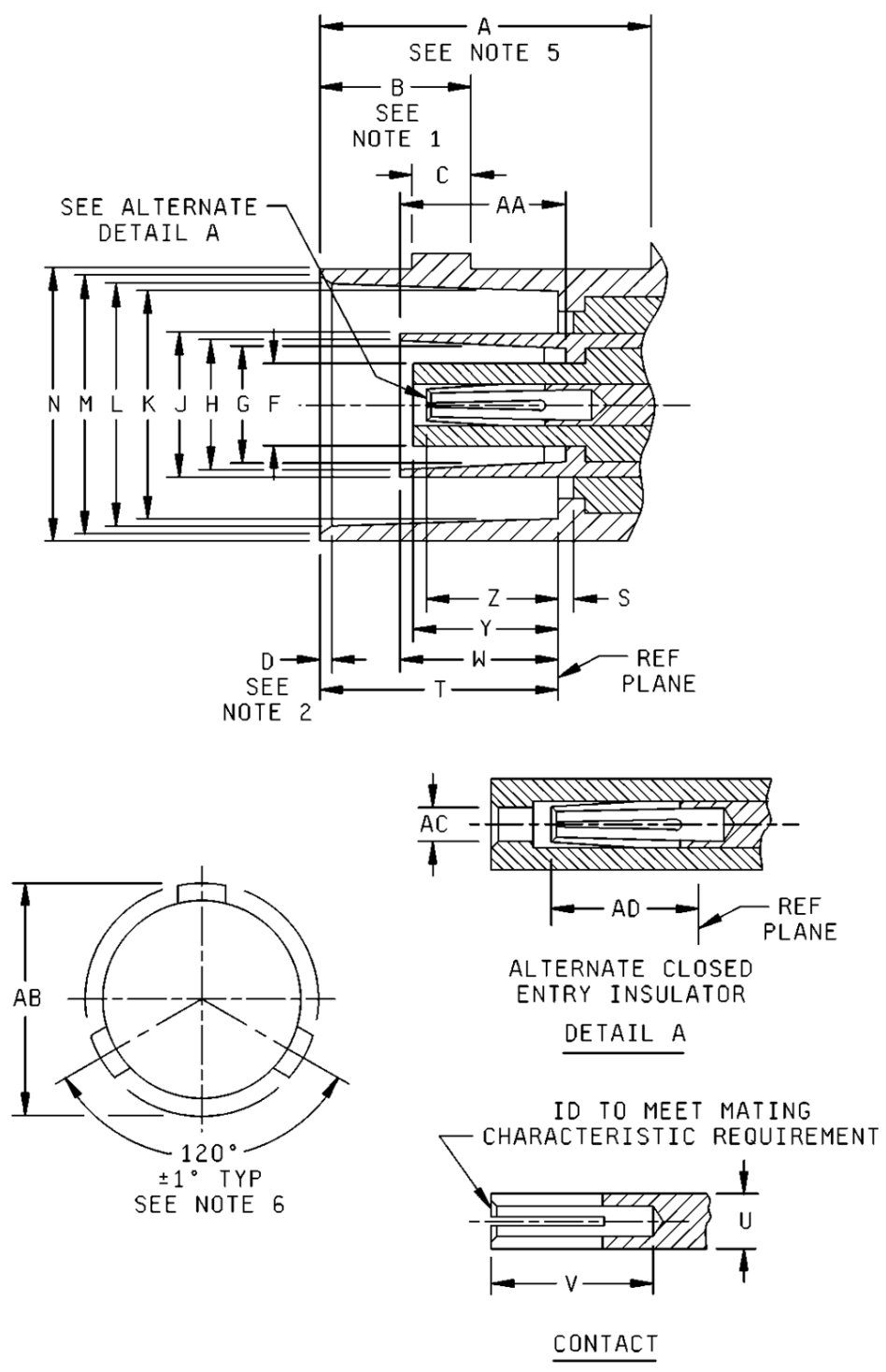

FIGURE 201-2. Interface, series TRB, socket contact.

MIL-STD-348B
 w/CHANGE 2

Ltr.	Inches (millimeters)	
	Minimum	Maximum
A	.414 (10.52)	-----
B	.204 (5.18)	.208 (5.28)
C	.075 (1.91)	.081 (2.06)
D	.015 (0.38)	.030 (0.76)
F	.117 (2.97)	.122 (3.10)
G	.169 (4.29)	.171 (4.34)
H	.178 (4.52)	.182 (4.62)
J	.195 (4.95)	.199 (5.05)
K	.319 (8.10)	.321 (8.15)
L	.327 (8.31)	.333 (8.46)
M	.346 (8.79)	.356 (9.04)
N	.378 (9.60)	.382 (9.70)
S	.001 (0.03)	-----
T	.327 (8.31)	.335 (8.51)
U	.062 (1.57)	.064 (1.63)
V	.200 (5.08)	-----
W	.187 (4.75)	.213 (5.41)
Y	-----	.213 (5.41)
Z	.165 (4.19)	.203 (5.16)
AA	.206 (5.23)	.213 (5.41)
AB	.432 (10.97)	.436 (11.07)
AC	.040 (1.02)	.043 (1.09)
AD	.133 (3.38)	.165 (4.19)

NOTES:

1. .005 (0.13 mm) flat permissible to meet dimension B.
2. Chamfer or radius.
3. Metric equivalents are in parentheses or tabulated.
4. This interface shall meet the gauge requirements of MIL-PRF-49142.
5. Clearance for mating connector coupling nut.
6. Standard polarization, see MIL-PRF-49142 for other options.
7. Dimensions are in inches.
8. Metric equivalents are for information only.

FIGURE 201-2. Interface, series TRB, socket contact – Continued.

MIL-STD-348B
 w/CHANGE 2

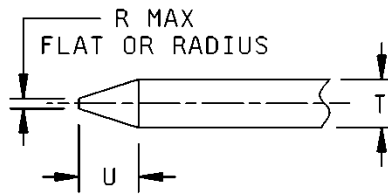
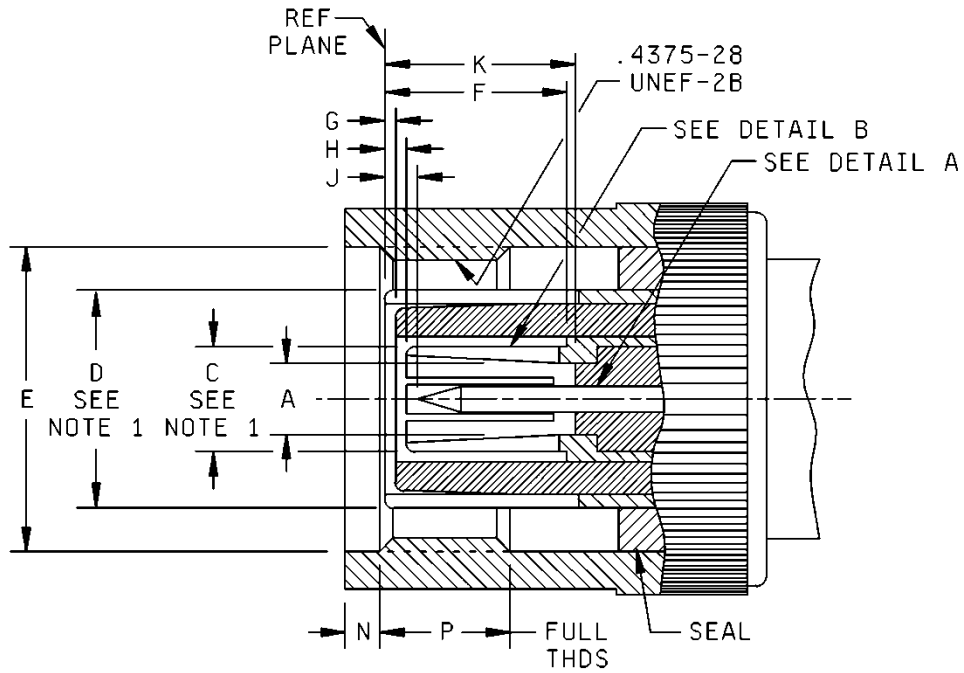

CENTER CONDUCTOR
 DETAIL A

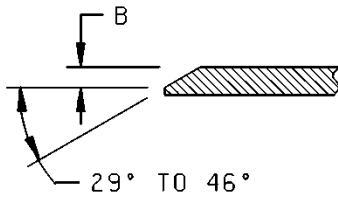

INTERMEDIATE CONDUCTOR
 DETAIL B

FIGURE 202-1. Interface, series TRT, pin contact.

MIL-STD-348B
 w/CHANGE 2

Ltr.	Inches (mm)	
	Min.	Max.
A	.123 (3.12)	-----
B	.005 (0.13)	.010 (0.25)
C	See note 1	
D		
E	.440 (11.18)	-----
F	.213 (5.41)	.242 (6.15)
G	.001 (0.03)	-----
H	.007 (0.18)	.033 (0.84)
J	.008 (0.20)	.042 (1.07)
K	.213 (5.41)	-----
N	.063 (1.60)	-----
P	.156 (3.96)	-----
R	-----	.010 (0.25)
T	.037 (0.94)	.039 (0.99)
U	.041 (1.04)	.061 (1.55)

NOTES:

1. Flared to meet mating characteristic test.
2. Metric equivalents are in parentheses or tabulated.
3. This interface shall meet the gauge requirements of MIL-PRF-49142.
4. Dimensions are in inches.
5. Metric equivalents are for information only.

FIGURE 202-1. Interface, series TRT, pin contact - Continued.

MIL-STD-348B
 w/CHANGE 2

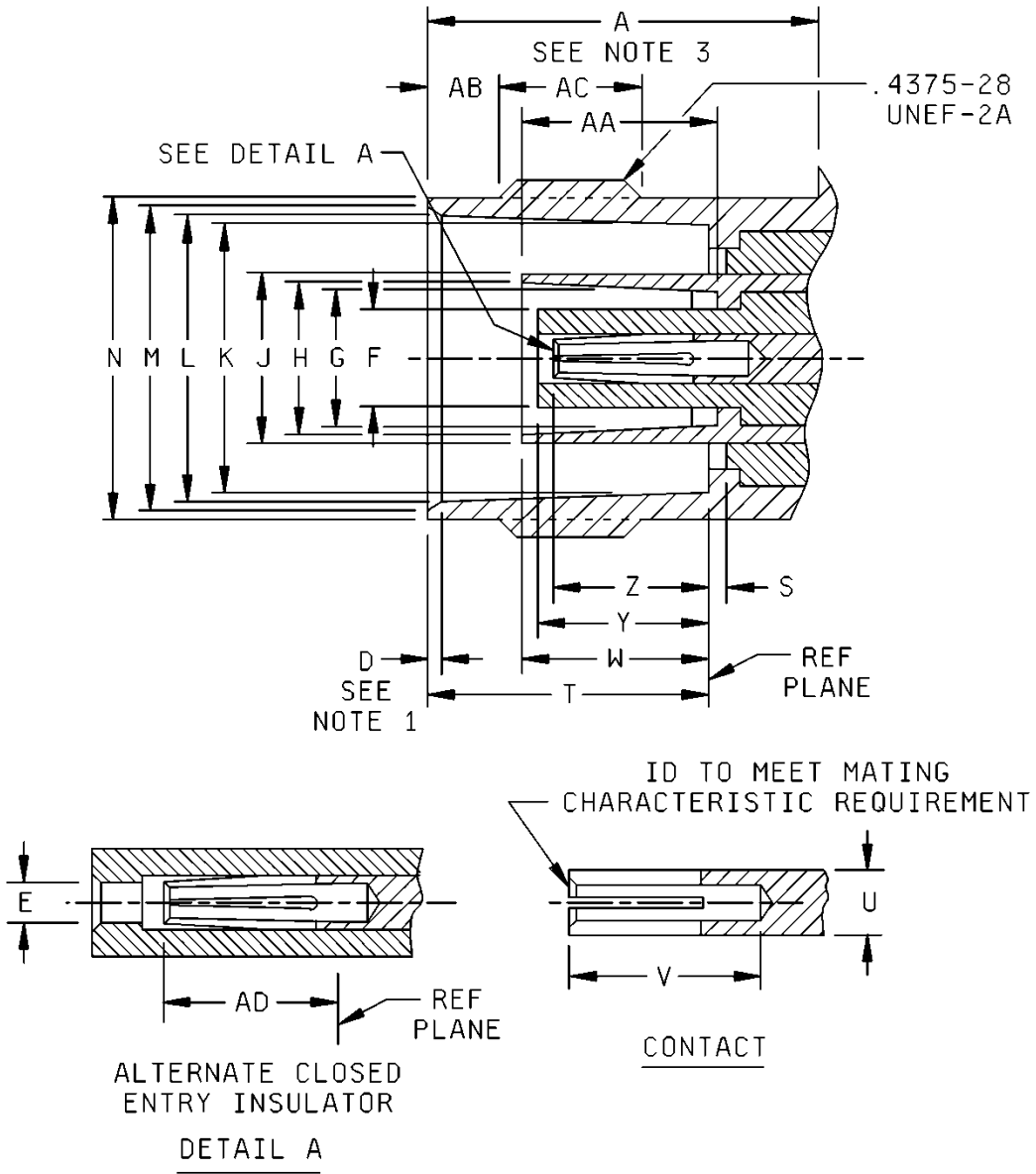

FIGURE 202-2. Interface, series TRT, socket contact.

MIL-STD-348B
 w/CHANGE 2

Ltr.	Inches (millimeter)	
	Min.	Max.
A	.414 (10.52)	-----
D	.015 (0.38)	.030 (0.76)
E	.040 (1.02)	.043 (1.09)
F	.117 (2.97)	.122 (3.10)
G	.169 (4.29)	.171 (4.34)
H	.178 (4.52)	.182 (4.62)
J	.195 (4.95)	.199 (5.05)
K	.319 (8.10)	.321 (8.15)
L	.327 (8.31)	.333 (8.46)
M	.346 (8.79)	.356 (9.04)
N	.378 (9.60)	.382 (9.70)
S	.001 (0.03)	-----
T	.327 (8.31)	.335 (8.51)
U	.062 (1.57)	.064 (1.63)
V	.200 (5.08)	-----
W	.187 (4.75)	.213 (5.41)
Y	-----	.213 (5.41)
Z	.165 (4.19)	.203 (5.16)
AA	.206 (5.23)	.213 (5.41)
AB	.068 (1.73)	.088 (2.24)
AC	.187 (4.75)	-----
AD	.133 (3.38)	.165 (4.19)

NOTES:

1. Chamfer or radius.
2. This interface shall meet the gauge requirements of MIL-PRF-49142.
3. Clearance for mating connector coupling nut.
4. Dimensions are in inches.
5. Metric equivalents are for information only.

FIGURE 202-2. Interface, series TRT, socket contact – Continued.

MIL-STD-348B
w/CHANGE 2

SECTION 300

Interface Dimensions for MIL-DTL-3643, MIL-DTL-3650, MIL-DTL-39012, MIL-DTL-55339 and MIL-DTL-83517

Section 301	Series BNC
Section 302	Series C
Section 303	Series MHV
Section 304	Series N
Section 305	Series QL
Section 306	Series QM
Section 307	Series QNC
Section 308	Series QSC
Section 309	Series SC
Section 310	Series SMA
Section 311	Series SMB
Section 312	Series SMC
Section 313	Series TNC
Section 313	Series TNCA
Section 314	Series SHV
Section 315	Series LC
Section 316	Series Environment resistant
Section 317	Series HN
Section 318	Series LT
Section 319	Series SSMA
Section 320	Series SSMB
Section 321	Series BMA
Section 322	Series BMB
Section 323	Series SMK
Section 324	Series 2.4 mm
Section 325	Series BMZ
Section 326	Series SMP
Section 327	Series DBA
Section 328	Series SMPM
Section 329	Series TK
Section 330	Series BNC
Section 331	Series N
Section 332	Series TNC

MIL-STD-348B
 w/CHANGE 2

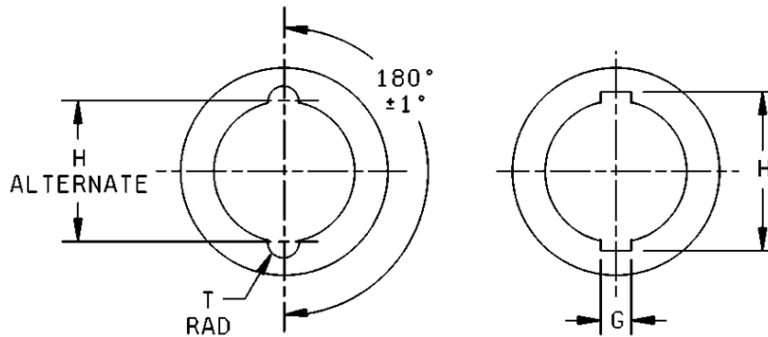
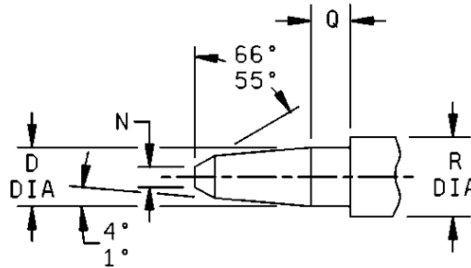
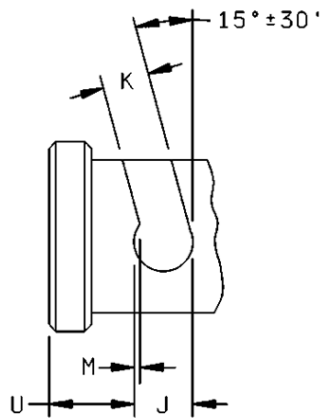
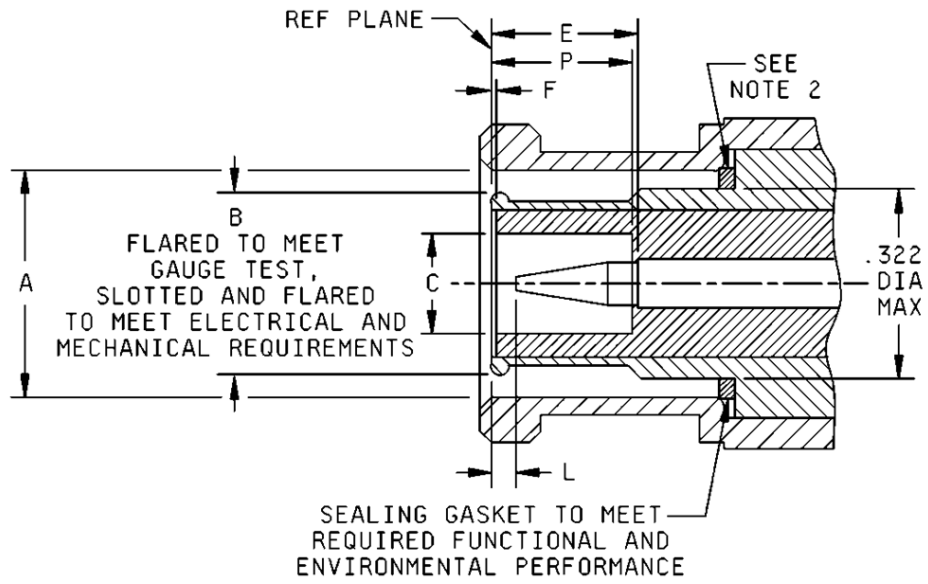

FIGURE 301-1. Interface, series BNC, pin contact.

**MIL-STD-348B
 w/CHANGE 2**

Dim. Ltr.	Inches (mm)	
	Minimum	Maximum
A	.385 (9.78)	.390 (9.91)
B	Gauge test	
C	.190 (4.83)	-----
D	.052 (1.32)	.054 (1.37)
E	.210 (5.33)	.230 (5.84)
F	.006 (0.15)	-----
G	.091 (2.31)	.097 (2.46)
H	.463 (11.76)	.473 (12.01)
H Alternate	.394 (10.01)	.400 (10.16)
J	.124 (3.15)	-----
K	.091 (2.31)	.097 (2.46)
L	.003 (0.08)	-----
M	.018 (0.46)	.022 (0.56)
N	-----	.025 (0.64)
P	.208 (5.28)	.228 (5.79)
Q	.078 (1.98)	-----
R	.081 (2.06)	.087 (2.21)
T	.045 (1.14)	.049 (1.24)
U	.180 (4.57)	.184 (4.67)

NOTES:

1. This interface shall meet the gauge requirements as specified in MIL-PRF-39012/16.
2. In the mated condition, the longitudinal force of the spring of the coupling mechanism shall exceed the pressure exerted by the sealing gasket by an amount necessary to insure butting of the outer contacts at the reference plane.

FIGURE 301-1. Interface, series BNC, pin contact – Continued.

MIL-STD-348B
 w/CHANGE 2

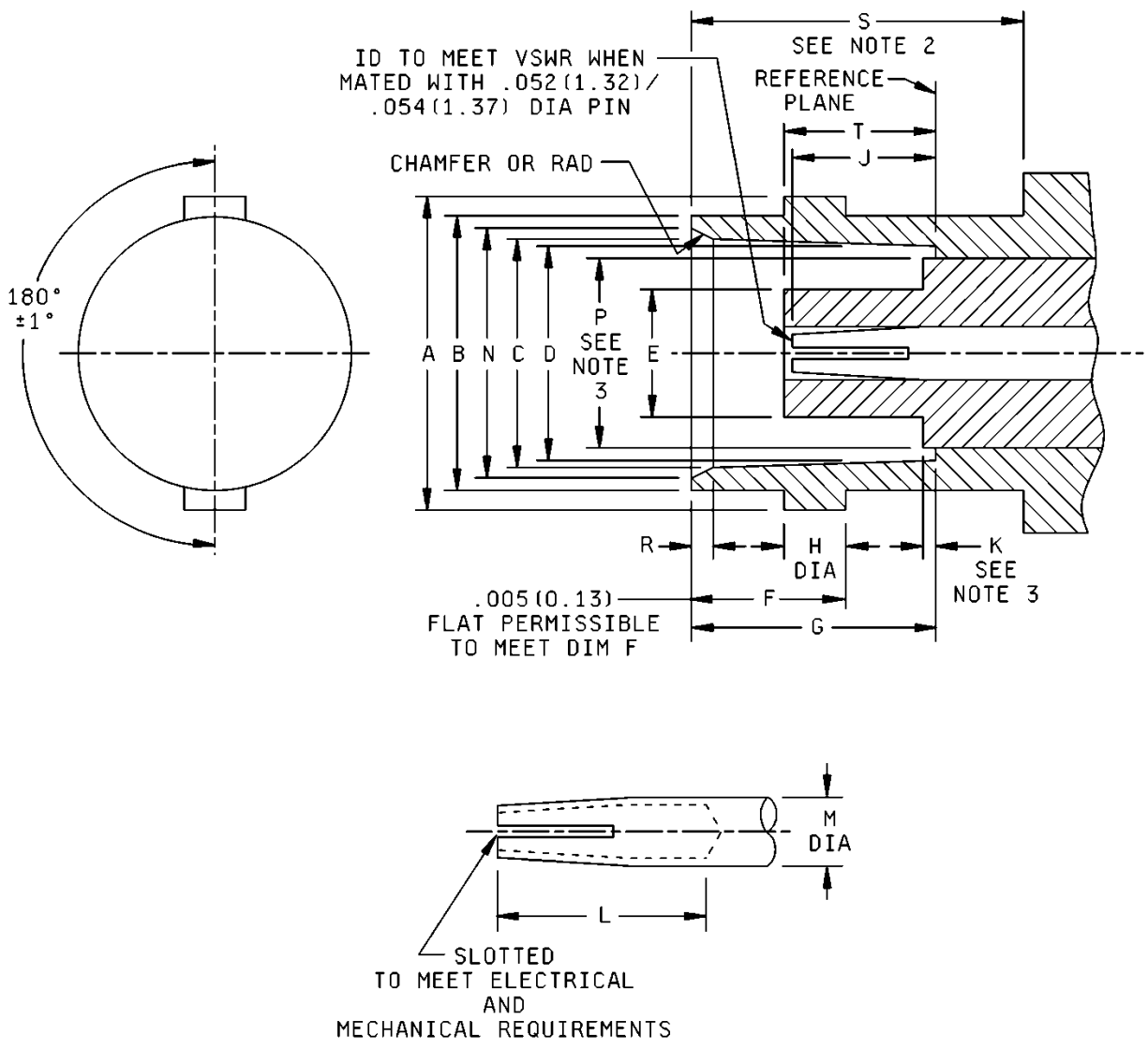

FIGURE 301-2. Interface, series BNC, socket contact.

MIL-STD-348B
 w/CHANGE 2

Dim. Ltr.	Inches (mm)	
	Minimum	Maximum
A	.432 (10.97)	.436 (11.07)
B	.378 (9.60)	.382 (9.70)
C	.327 (8.31)	.333 (8.46)
D	.319 (8.10)	.321 (8.15)
E	-----	.186 (4.72)
F	.204 (5.18)	.208 (5.28)
G	.327 (8.31)	.335 (8.51)
H	.075 (1.91)	.081 (2.06)
J	.186 (4.72)	.206 (5.23)
K	-----	.006 (0.15)
L	.195 (4.95)	-----
M	.081 (2.06)	.087 (2.21)
N	.346 (8.79)	.356 (9.04)
P	-----	.256 (6.50)
R	.015 (0.38)	.030 (0.76)
S	.414 (10.52)	-----
T	.188 (4.78)	.208 (5.28)

NOTES:

1. This interface shall meet the gauge requirements as specified in MIL-PRF-39012/17.
2. Clearance for mating connector coupling nut.
3. P dimension applies to that portion (if applicable) of dielectric which extends beyond reference plane by dimension K.

FIGURE 301-2. Interface, series BNC, socket contact - Continued.

MIL-STD-348B
 w/CHANGE 2

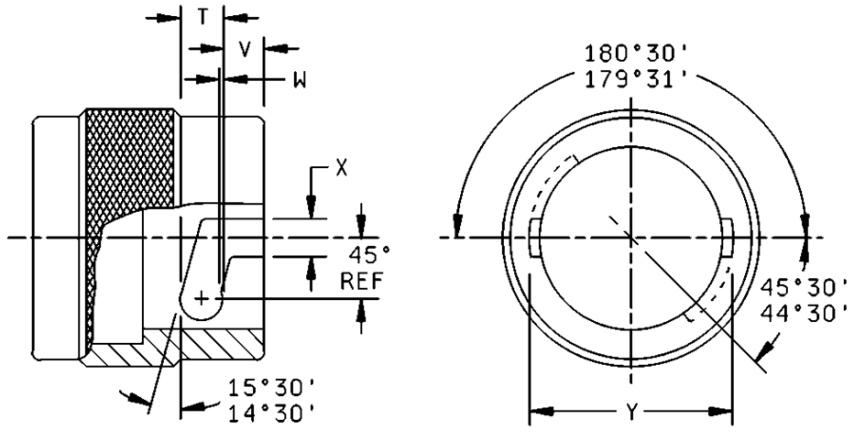
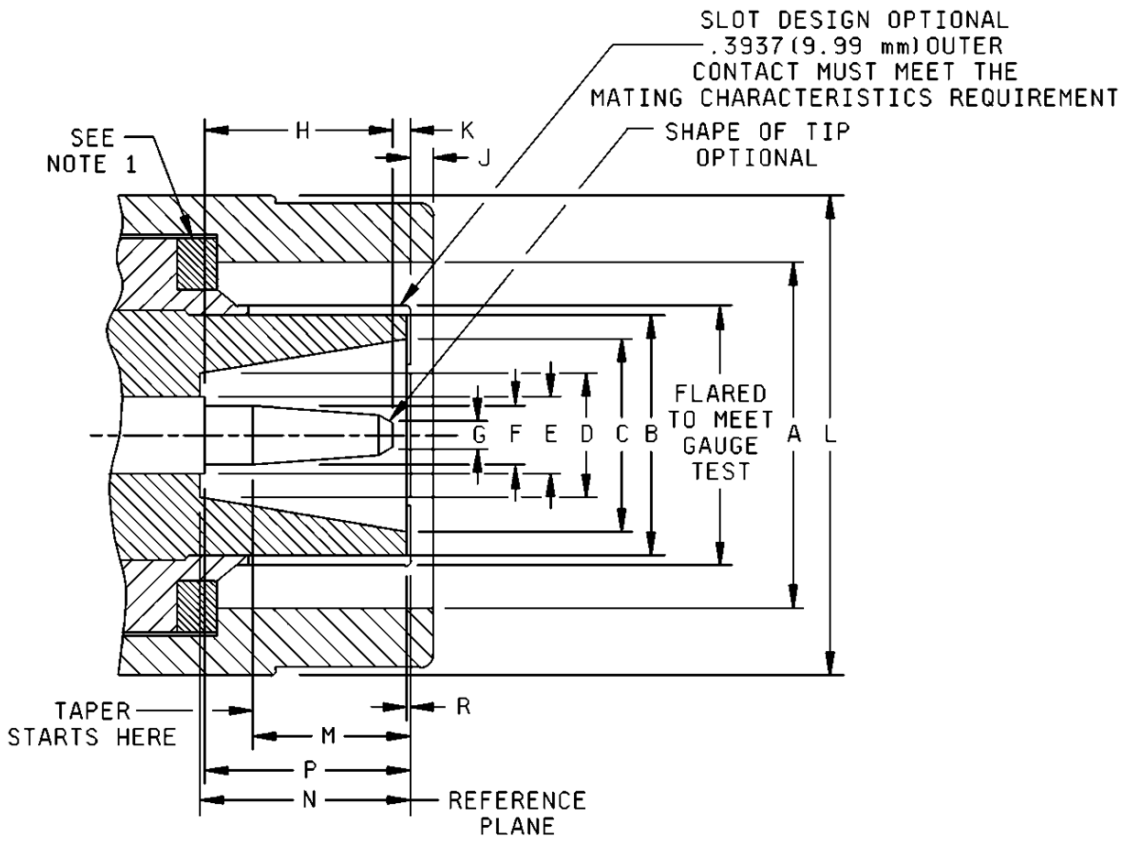

FIGURE 302-1. Interface, series C, pin contact.

MIL-STD-348B
 w/CHANGE 2

Dim. Ltr.	Inches (mm)	
	Minimum	Maximum
A	.543 (13.79)	.549 (13.94)
B	.377 (9.58)	-----
C	.276 (7.01)	-----
D	.194 (4.93)	-----
E	.119 (3.02)	.124 (3.15)
F	.090 (2.29)	.092 (2.34)
G	-----	.050 (1.27)
H	.297 (7.54)	.304 (7.72)
J	-----	.085 (2.16)
K	.003 (0.08)	.040 (1.02)
L	-----	.781 (19.84)
M	.191 (4.85)	.251 (6.38)
N	.309 (7.85)	-----
P	.307 (7.80)	.337 (8.56)
R	.007 (0.18)	-----
T	.131 (3.33)	.141 (3.58)
V	.103 (2.62)	.113 (2.87)
W	.010 (0.25)	.016 (0.41)
X	.104 (2.64)	.114 (2.90)
Y	.612 (15.54)	-----

NOTES:

1. In the mated condition, the longitudinal force of the spring of the coupling mechanism shall exceed the pressure exerted by the sealing gasket by an amount necessary to insure butting of the outer contacts at the reference plane.
2. This interface shall meet the gauge requirements as specified in MIL-PRF-39012/6.
3. The ID of the outer contact when inserted into a .411 inch (10.44 mm) maximum ring gauge shall be .377 inch (9.58 mm) minimum.

FIGURE 302-1. Interface, series C, pin contact - Continued.

MIL-STD-348B
 w/CHANGE 2

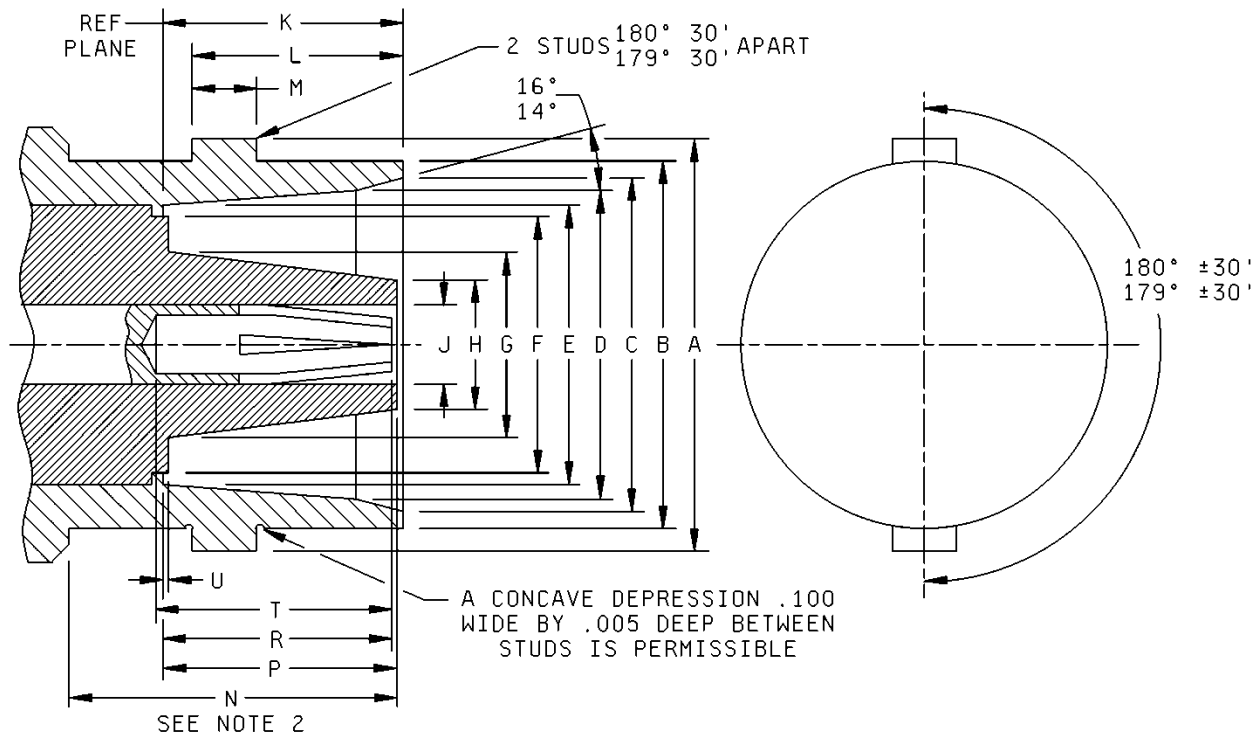

FIGURE 302-2. Interface, series C, socket contact.

**MIL-STD-348B
 w/CHANGE 2**

Dim. Ltr.	Inches (mm)	
	Minimum	Maximum
A	.590 (14.99)	.600 (15.24)
B	.530 (13.46)	.540 (13.72)
C	.485 (12.32)	.495 (12.57)
D	.440 (11.18)	.450 (11.43)
E	.411 (10.44)	.415 (10.54)
F	-----	.374 (9.50)
G	-----	.272 (6.91)
H	-----	.190 (4.83)
J	.119 (3.02)	.124 (3.15)
K	.332 (8.43)	.338 (8.59)
L	.307 (7.80)	.313 (7.95)
M dia.	.088 (2.24)	.098 (2.49)
N	.495 (12.57)	-----
P	-----	.309 (7.85)
R	.273 (6.93)	.303 (7.70)
T	.300 (7.62)	-----
U	-----	.007 (0.18)

NOTES:

1. This interface shall meet the gauge requirements as specified in MIL-PRF-39012/7.
2. Clearance for mating connector coupling nut.

FIGURE 302-2. Interface, series C, socket contact – Continued.

MIL-STD-348B
 w/CHANGE 2

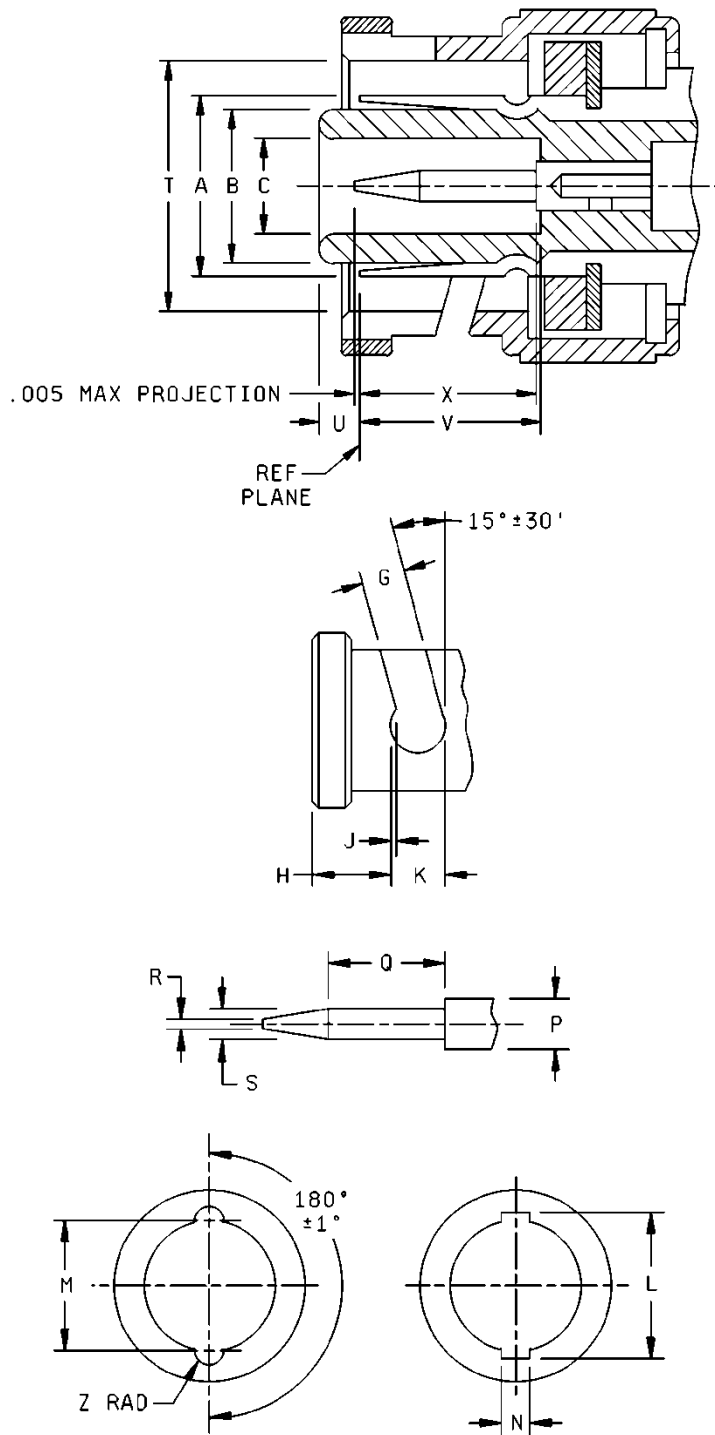

FIGURE 303-1. Interface, series MHV, pin contact.

MIL-STD-348B
 w/CHANGE 2

Dim. Ltr.	Inches (mm)	
	Min.	Max.
A	Gauge test	
B	.278 (7.06)	.282 (7.16)
C	.190 (4.83)	.194 (4.93)
G	.091 (2.31)	.097 (2.46)
H	.180 (4.57)	.184 (4.67)
J	.018 (0.46)	.022 (0.56)
K	.124 (3.15)	-----
L	.463 (11.76)	.473 (12.01)
M	.394 (10.01)	.400 (10.16)
N	.091 (2.31)	.097 (2.46)
P	.089 (2.26)	.091 (2.31)
Q	.207 (5.26)	-----
R	-----	.025 (0.64)
S	.052 (1.32)	.054 (1.37)
T	.385 (9.78)	.390 (9.91)
U	-----	.086 (2.18)
V	.302 (7.67)	-----
X	.300 (7.62)	-----
Z	.045 (1.14)	.049 (1.24)

NOTE: This interface shall meet the gauge requirements as specified in MIL-PRF-39012/100.

FIGURE 303-1. Interface, series MHV, pin contact - Continued.

MIL-STD-348B
w/CHANGE 2

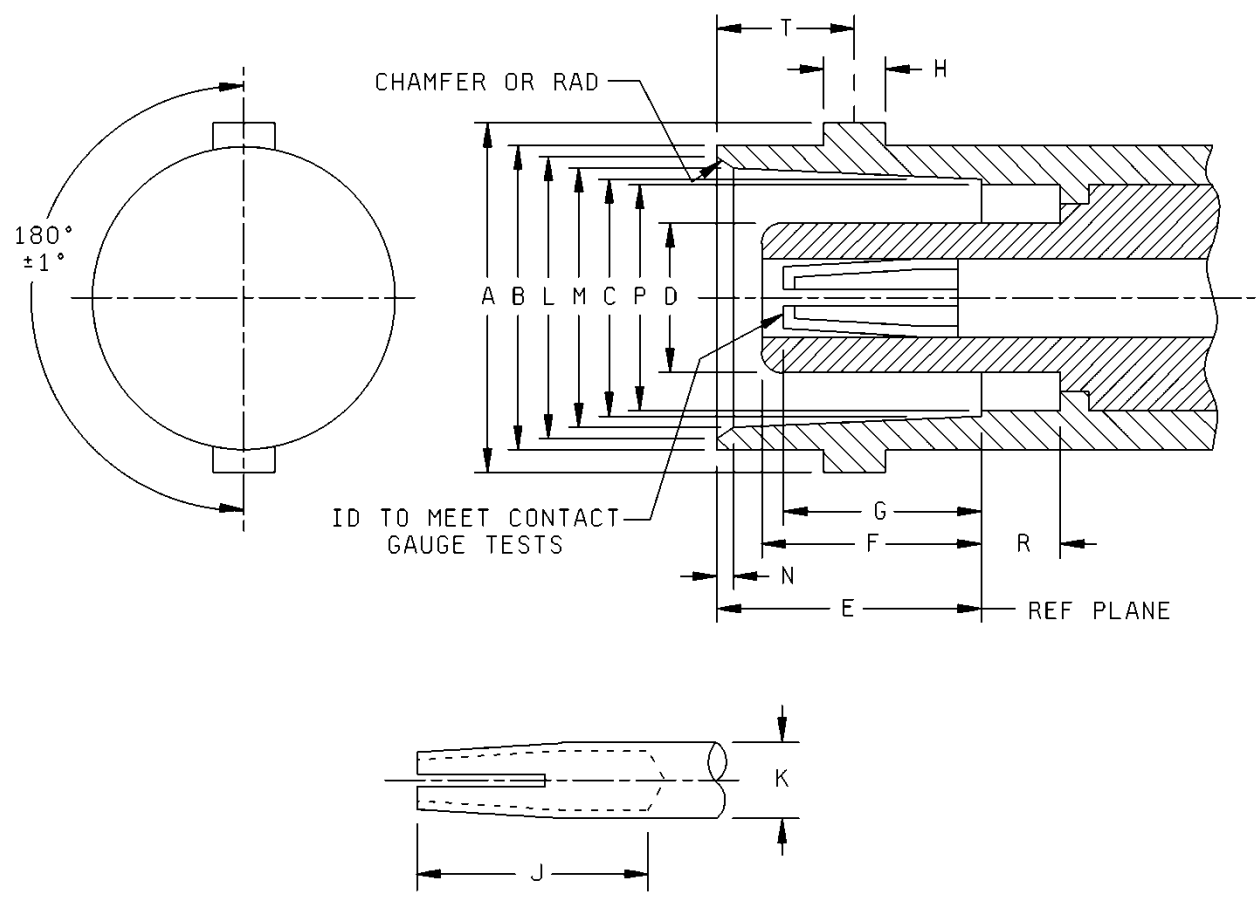

FIGURE 303-2. Interface, series MHV, socket contact.

MIL-STD-348B
 w/CHANGE 2

Dim. Ltr.	Inches (mm)	
	Min.	Max.
A	.432 (10.97)	.436 (11.07)
B	.378 (9.60)	.382 (9.70)
C	.319 (8.10)	.321 (8.15)
D	-----	.186 (4.72)
E	.327 (8.31)	.335 (8.51)
F	.289 (7.34)	.311 (7.90)
G	.253 (6.43)	.280 (7.11)
H	.075 (1.91)	.081 (2.06)
J	.270 (6.86)	-----
K	.081 (2.06)	.091 (2.31)
L	.346 (8.79)	.356 (9.04)
M	.327 (8.31)	.333 (8.46)
N	.015 (.38)	.030 (0.76)
P	.284 (7.21)	.290 (7.37)
R	.086 (2.18)	-----
T	.165 (4.19)	.169 (4.29)

FIGURE 303-2. Interface, series MHV, socket contact - Continued.

MIL-STD-348B
 w/CHANGE 2

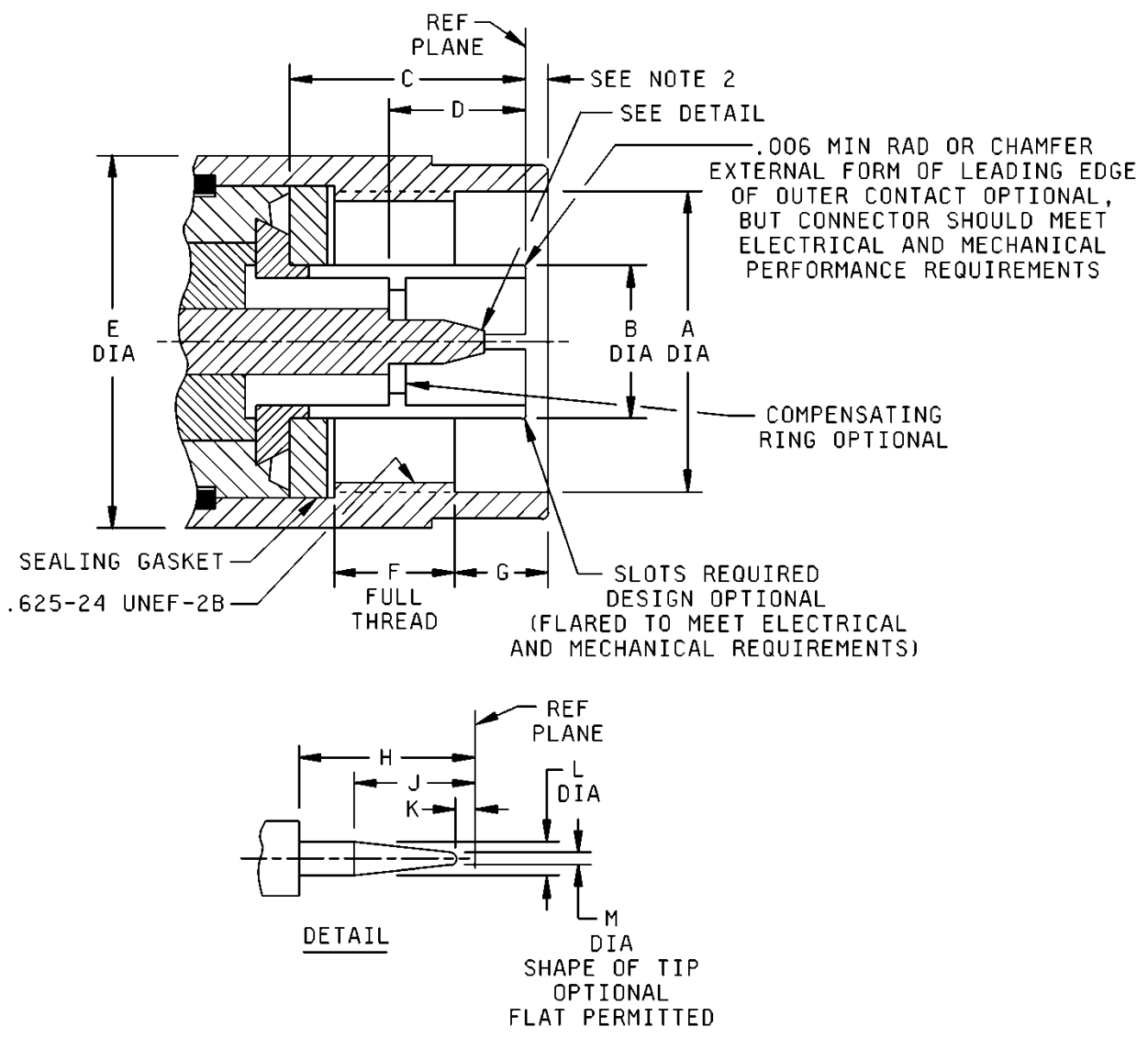

FIGURE 304-1. Interface, series N, pin contact.

MIL-STD-348B
 w/CHANGE 2

Dim. Ltr.	Inches (mm)	
	Min.	Max.
A Dia.	.630 (16.00)	-----
B Dia.	-----	.330 (8.38)
C	.398 (10.11)	.412 (10.46)
D	.210 (5.33)	.230 (5.84)
E Dia.	-----	.827 (21.01)
F	.177 (4.50)	-----
G	.158 (4.01)	.168 (4.27)
H	.210 (5.33)	-----
J	.110 (2.79)	.140 (3.56)
K	.003 (.08)	-----
L	.063 (1.60)	.066 (1.68)
M	-----	.010 (0.25)

NOTE:

1. This interface shall meet the gauge requirements as specified in MIL-PRF-39012/1.
2. When nut is biased fully forward, the maximum dimension permitted is .060 inch (1.52 mm). When nut is biased fully back, the minimum dimension permitted is .016 inch (0.41 mm).

FIGURE 304-1. Interface, series N, pin contact - Continued.

MIL-STD-348B
 w/CHANGE 2

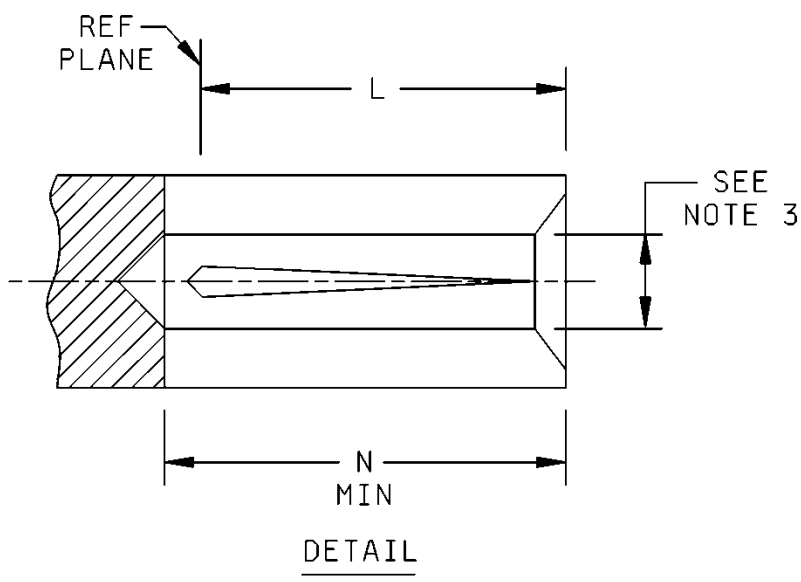
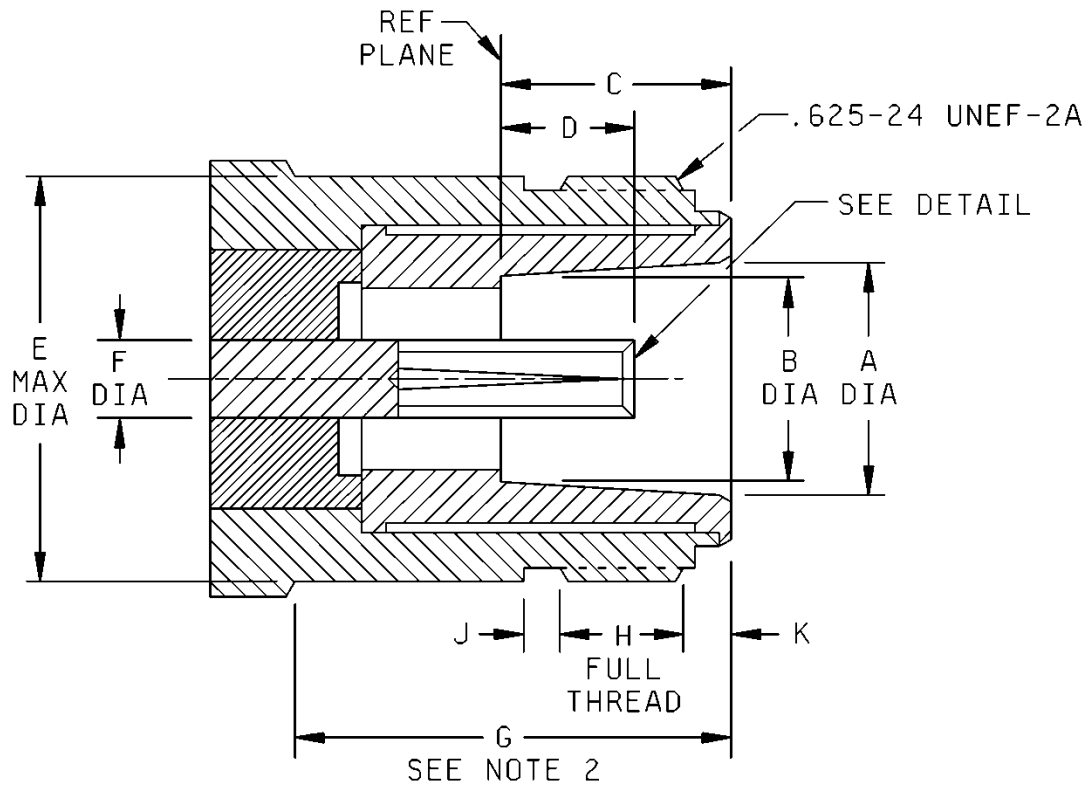

FIGURE 304-2. Interface, series N, socket contact.

MIL-STD-348B
 w/CHANGE 2

Dim. Ltr.	Inches (mm)	
	Min.	Max.
A	.336 (8.53)	.344 (8.74)
B	.316 (8.03)	.320 (8.13)
C	.356 (9.04)	.362 (9.19)
D	.187 (4.75)	.207 (5.26)
E	-----	.627 (15.93)
F	.119 (3.02)	.124 (3.15)
G	.422 (10.72)	-----
H	.172 (4.37)	.220 (5.59)
J	.047 (1.19)	.077 (1.96)
K	.047 (1.19)	.077 (1.96)
L	.187 (4.75)	.207 (5.26)
N	.210 (5.33)	-----

NOTES:

1. This interface shall meet the gauge requirements as specified in MIL-PRF-39012/2.
2. Clearance for mating connector coupling nut.
3. To meet VSWR, mating characteristics, contact resistance and connector durability when mated with a .063/.066 diameter pin.

FIGURE 304-2. Interface, series N, socket contact - Continued.

MIL-STD-348B
 w/CHANGE 2

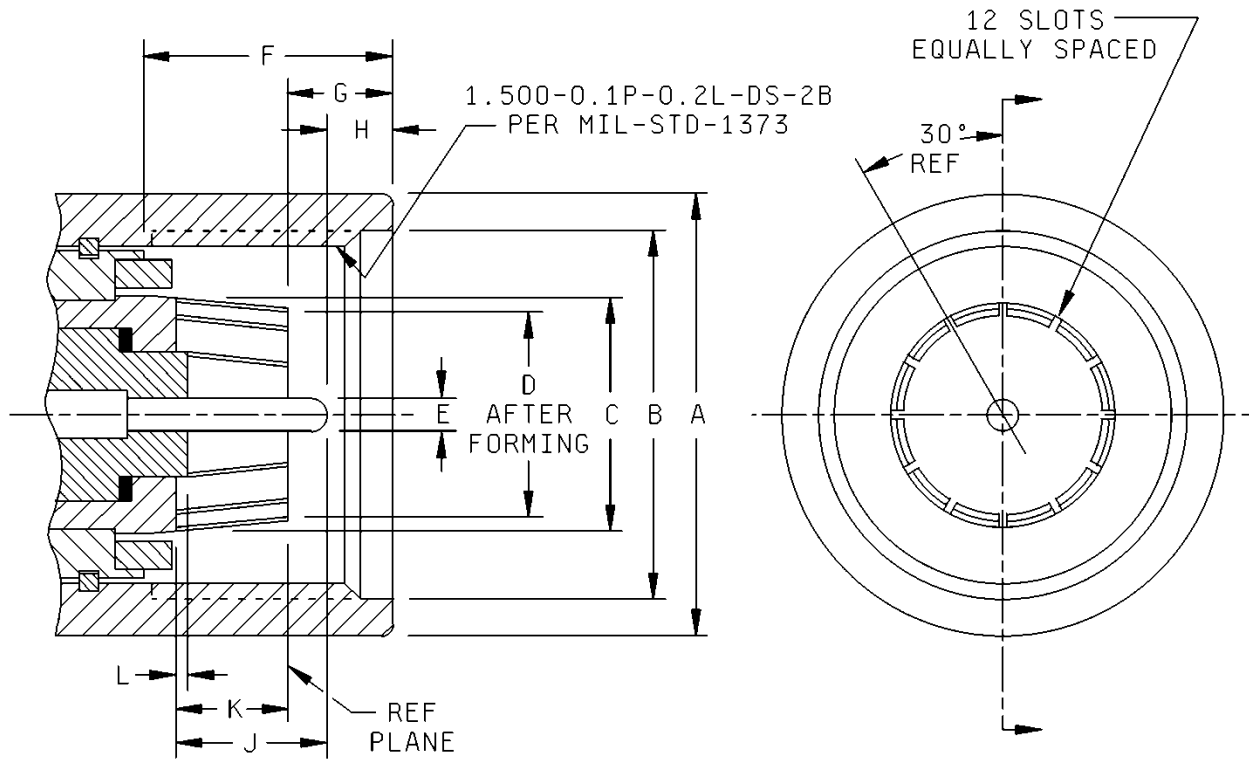

Dim. Ltr.	Inches (mm)	
	Min.	Max.
A	1.740 (44.20)	1.760 (44.70)
B	1.537 (39.04)	1.543 (39.19)
C	1.060 (26.92)	1.064 (27.03)
D	.964 (24.49)	.974 (24.74)
E	.194 (4.93)	.196 (4.98)
F	.836 (21.23)	.856 (21.74)
G	.372 (9.45)	.392 (9.96)
H	.271 (6.88)	.291 (7.39)
J	.551 (14.00)	.571 (14.50)
K	.370 (9.40)	.380 (9.65)
L	.001 (0.03)	.013 (0.33)

NOTES:

1. This interface shall meet the gauge requirements as specified in MIL-PRF-39012/44.

FIGURE 305-1. Interface, series QL, pin contact.

MIL-STD-348B
 w/CHANGE 2

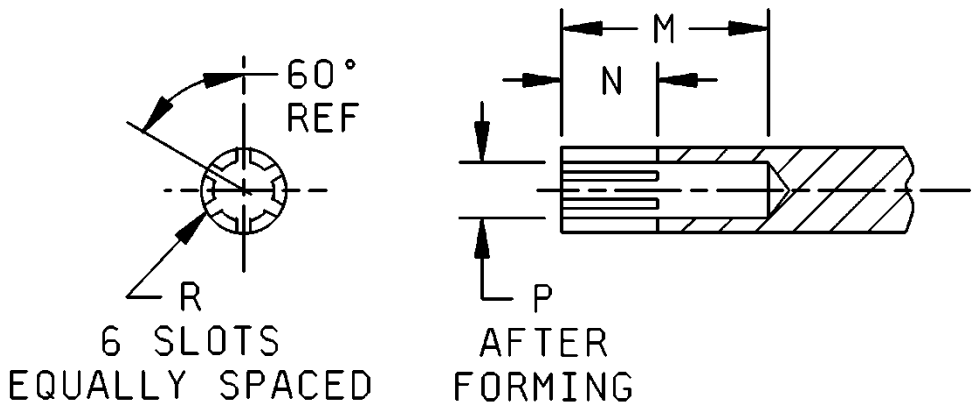
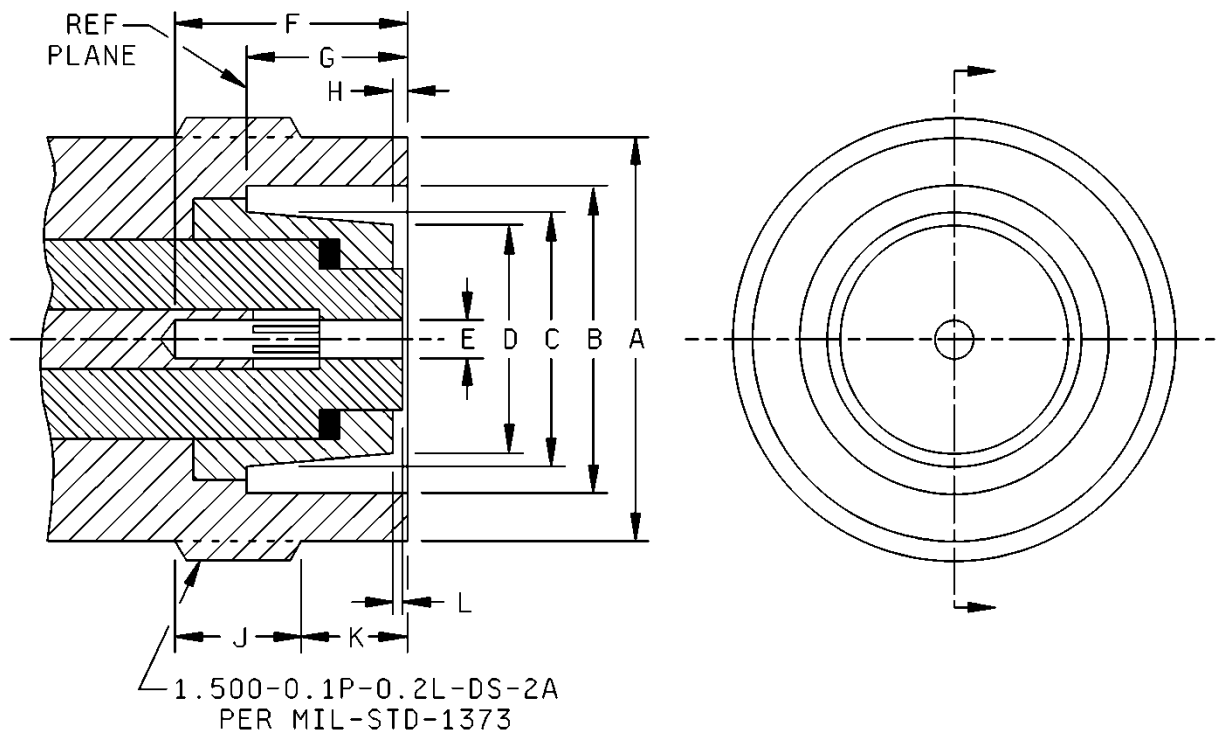

CENTER CONTACT DETAIL

FIGURE 305-2. Interface, series QL, socket contact.

**MIL-STD-348B
 w/CHANGE 2**

Dim. Ltr.	Inches (mm)	
	Min.	Max.
A	1.404 (35.66)	1.408 (35.76)
B	1.100 (27.94)	1.120 (28.45)
C	1.998 (50.75)	1.002 (25.45)
D	.936 (23.77)	.940 (23.88)
E	.191 (4.85)	.195 (4.95)
F	.763 (19.38)	.783 (19.89)
G	.465 (11.81)	.485 (12.32)
H	.062 (1.57) Reference	
J	.302 (7.67)	.322 (8.18)
K	.302 (7.67)	.322 (8.18)
L	.001 (0.03)	.013 (0.33)
M	.490 (12.45)	.510 (12.95)
N	.240 (6.10)	.260 (6.60)
P	.187 (4.75)	.189 (4.80)
R	.014 (0.36)	.018 (0.46)

NOTES:

1. This interface shall meet the gauge requirements as specified in MIL-PRF-39012/45.

FIGURE 305-2. Interface, series QL, socket contact - Continued.

MIL-STD-348B
 w/CHANGE 2

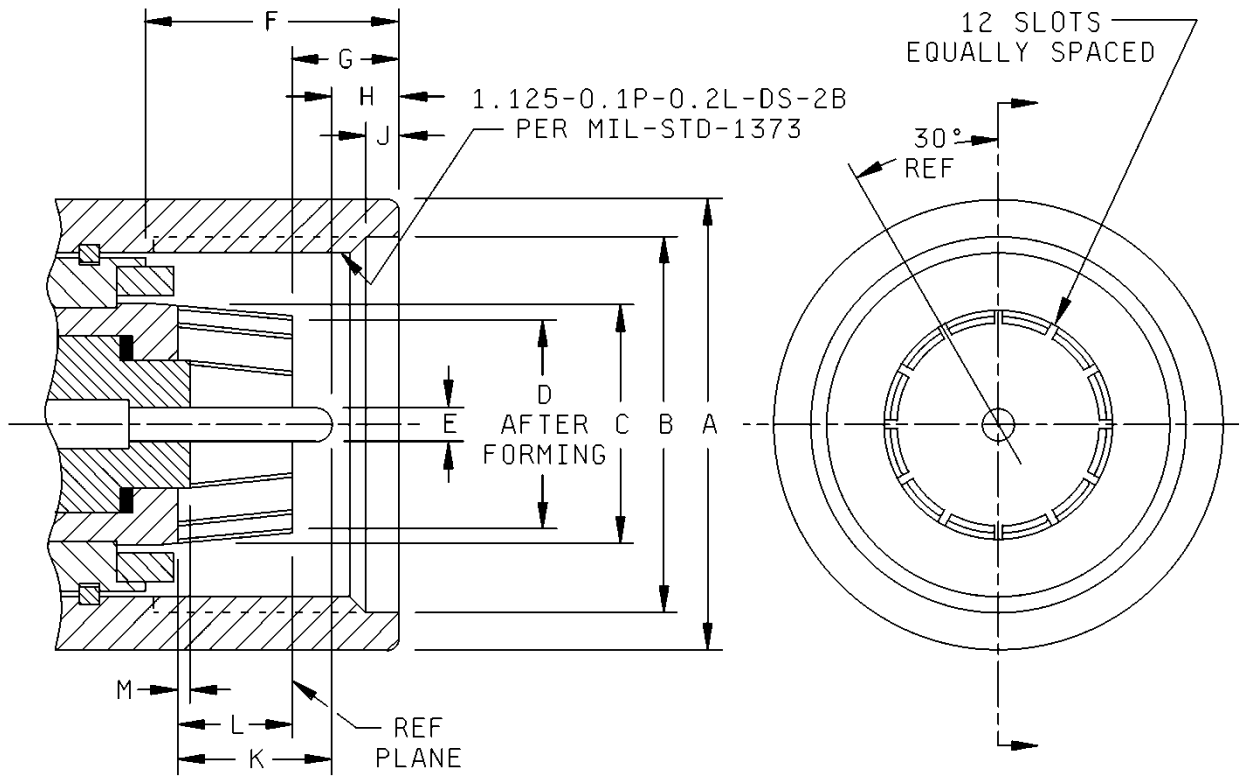

Dim. Ltr.	Inches (mm)	
	Min.	Max.
A	1.365 (34.67)	1.385 (35.18)
B	1.161 (29.49)	1.167 (29.64)
C	.701 (17.81)	.705 (17.91)
D	.611 (15.52)	.613 (15.57)
E	.105 (2.67)	.107 (2.72)
F	.683 (17.35)	.703 (17.86)
G	.258 (6.55)	.278 (7.06)
H	.142 (3.61)	.162 (4.11)
J	.147 (3.73)	.167 (4.24)
K	.510 (12.95)	.530 (13.46)
L	.339 (8.61)	.349 (8.86)
M	.001 (0.03)	.013 (0.33)

NOTES:

1. This interface shall meet the gauge requirements as specified in MIL-PRF-39012/48.

FIGURE 306-1. Interface, series QM, pin contact.

MIL-STD-348B
 w/CHANGE 2

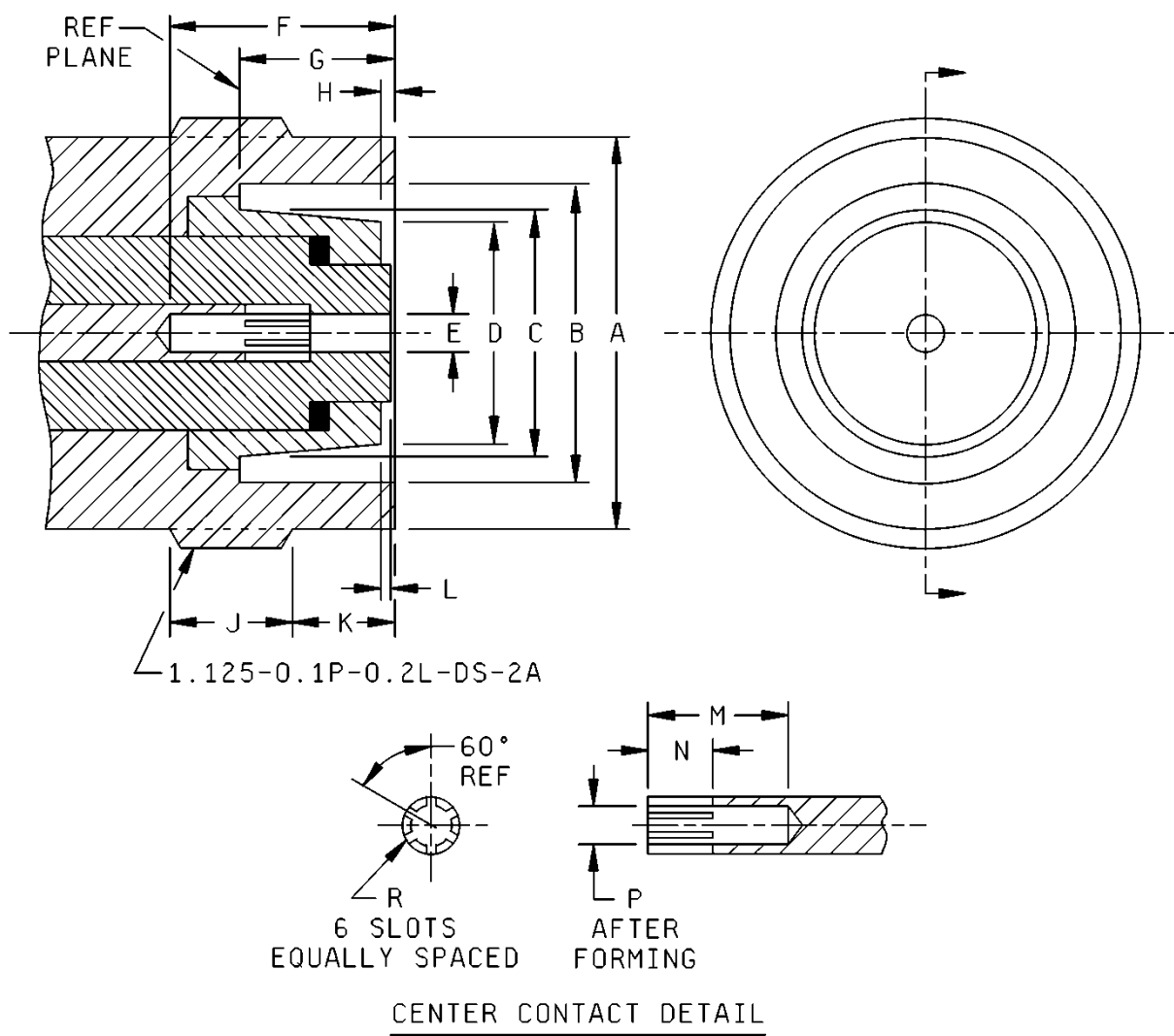

FIGURE 306-2. Interface, series QM, socket contact.

**MIL-STD-348B
 w/CHANGE 2**

Dim. Ltr.	Inches (mm)	
	Min.	Max.
A	1.029 (26.14)	1.033 (26.24)
B	.720 (18.29)	.760 (19.30)
C	.639 (16.23)	.643 (16.33)
D	.592 (15.04)	.596 (15.14)
E	.100 (2.54)	.104 (2.64)
F	.580 (14.73)	.600 (15.24)
G	.411 (10.44)	.431 (10.95)
H	.036 (0.91)	.056 (1.42)
J	.302 (7.67)	.322 (8.18)
K	.209 (5.31)	.229 (5.82)
L	.001 (0.03)	.013 (0.33)
M	.365 (9.27)	.385 (9.78)
N	.165 (4.19)	.185 (4.70)
P	.101 (2.57)	.103 (2.62)
R	.008 (0.20)	.012 (0.30)

NOTES:

1. This interface shall meet the gauge requirements as specified in MIL-PRF-39012/49.

FIGURE 306-2. Interface, series QM, socket contact - Continued.

MIL-STD-348B
 w/CHANGE 2

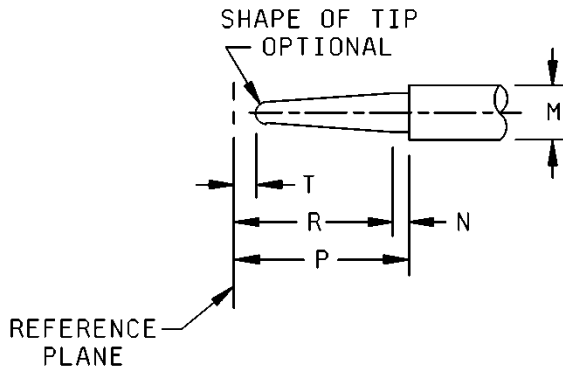
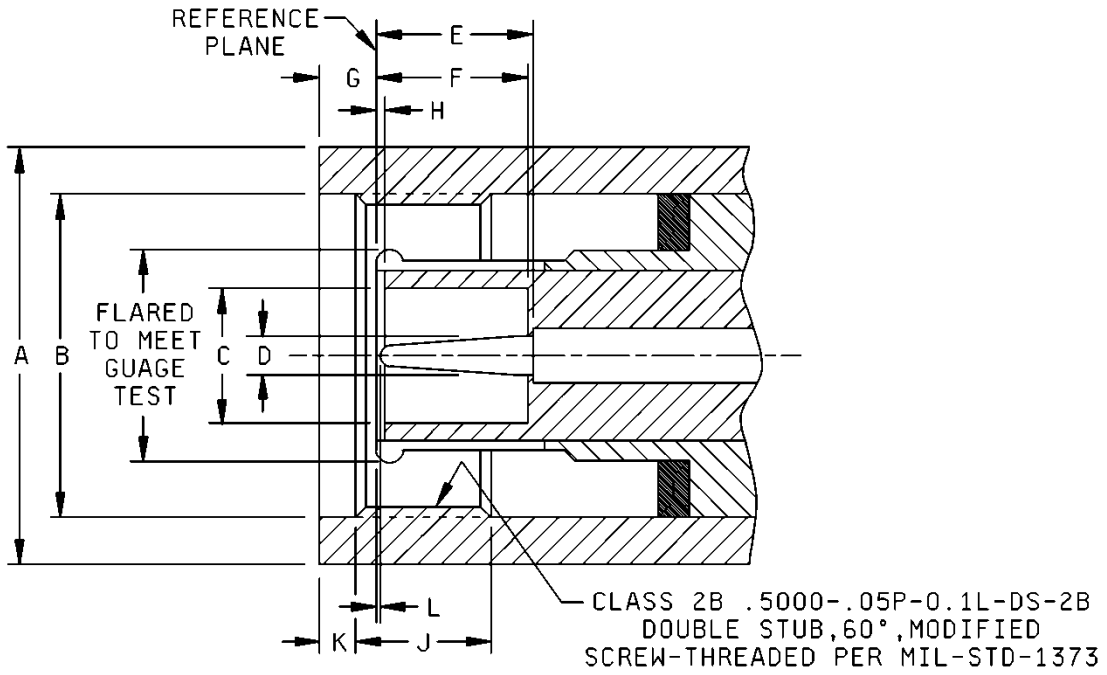

FIGURE 307-1. Interface, series QNC, pin contact.

MIL-STD-348B
 w/CHANGE 2

Dim. Ltr.	Inches (mm)	
	Min.	Max.
A	.640 (16.26)	.660 (16.76)
B	.516 (13.11)	.519 (13.18)
C	.190 (4.83)	-----
D	.052 (1.32)	.054 (1.37)
E	.210 (5.33)	-----
F	.208 (5.28)	-----
G	-----	.140 (3.56)
H	.006 (0.15)	-----
J	.271 (6.88)	.291 (7.39)
K	.088 (2.24)	.098 (2.49)
L	.003 (0.08)	-----
M	.081 (2.06)	.087 (2.21)
N	.003 (0.08)	-----
P	.210 (5.33)	-----
R	.120 (3.05)	.155 (3.94)
T	.003 (0.08)	-----

FIGURE 307-1. Interface, series QNC, pin contact - Continued.

MIL-STD-348B
 w/CHANGE 2

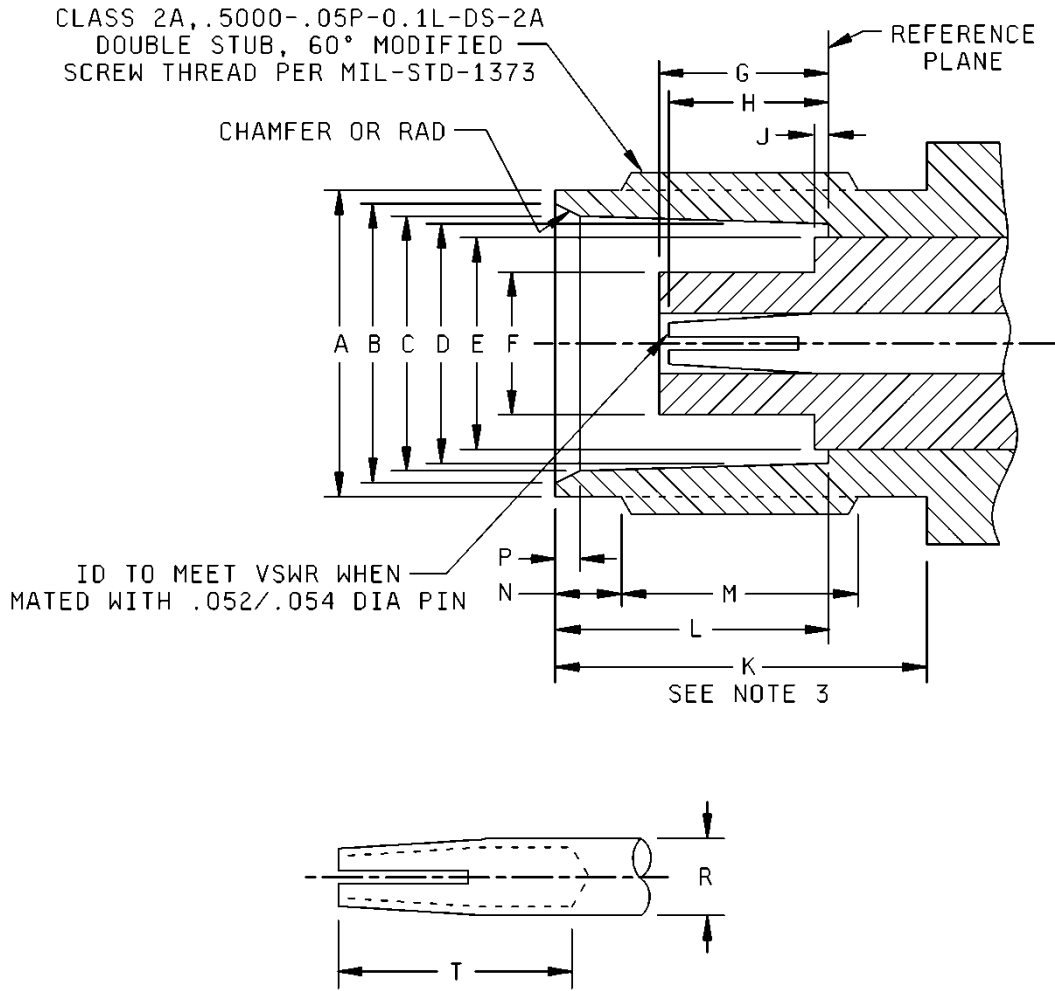

FIGURE 307-2. Interface, series QNC, socket contact.

MIL-STD-348B
 w/CHANGE 2

Dim. Ltr.	Inches (mm)	
	Min.	Max.
A	.446 (11.33)	.449 (11.40)
B	.345 (8.76)	.356 (9.04)
C	.327 (8.31)	.333 (8.46)
D	.319 (8.10)	.321 (8.15)
E	-----	.256 (6.50)
F	-----	.186 (4.72)
G	-----	.208 (5.28)
H	-----	.206 (5.23)
J	-----	.006 (0.15)
K	-----	.477 (12.12)
L	.327 (8.31)	.335 (8.51)
M	.271 (6.88)	.291 (7.39)
N	.088 (2.24)	.098 (2.49)
P	.015 (0.38)	.030 (0.76)
R	.081 (2.06)	.087 (2.21)
T	.195 (4.95)	-----

NOTES:

1. This interface shall meet the gauge requirements as specified in MIL-PRF-39012/89.
2. The .256 dimension applies to that portion (if applicable) of the dielectric which protrudes beyond the metal shoulder (or reference plane) by dimension .006.
3. Clearance for mating connector coupling nut.

FIGURE 307-2. Interface, series QNC, socket contact - Continued.

MIL-STD-348B
 w/CHANGE 2

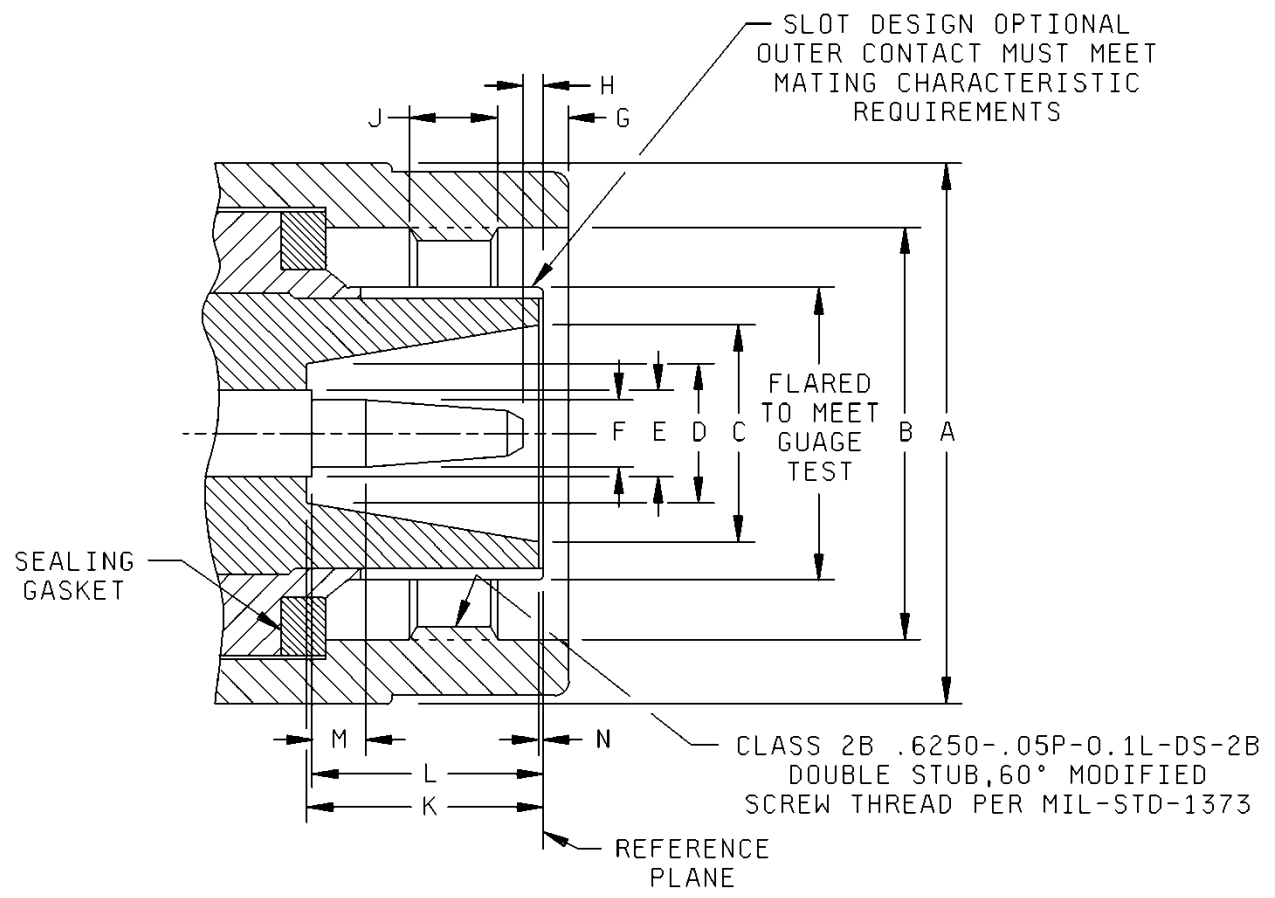

FIGURE 308-1. Interface, series QSC, pin contact.

**MIL-STD-348B
 w/CHANGE 2**

Dim. Ltr.	Inches (mm)	
	Min.	Max.
A	-----	.781 (19.84)
B	.642 (16.31)	.645 (16.38)
C	.276 (7.01)	-----
D	.194 (4.93)	-----
E	.119 (3.02)	.124 (3.15)
F	.090 (2.29)	.092 (2.34)
G	.088 (2.24)	.098 (2.49)
H	.003 (0.08)	-----
J	.271 (6.88)	.291 (7.39)
K	.309 (7.85)	-----
L	.307 (7.80)	.337 (8.56)
M	.093 (2.36)	-----
N	.007 (0.18)	-----

NOTE: This interface shall meet the gauge requirements as specified in MIL-PRF-39012/84.

FIGURE 308-1. Interface, series QSC, pin contact – Continued.

MIL-STD-348B
 w/CHANGE 2

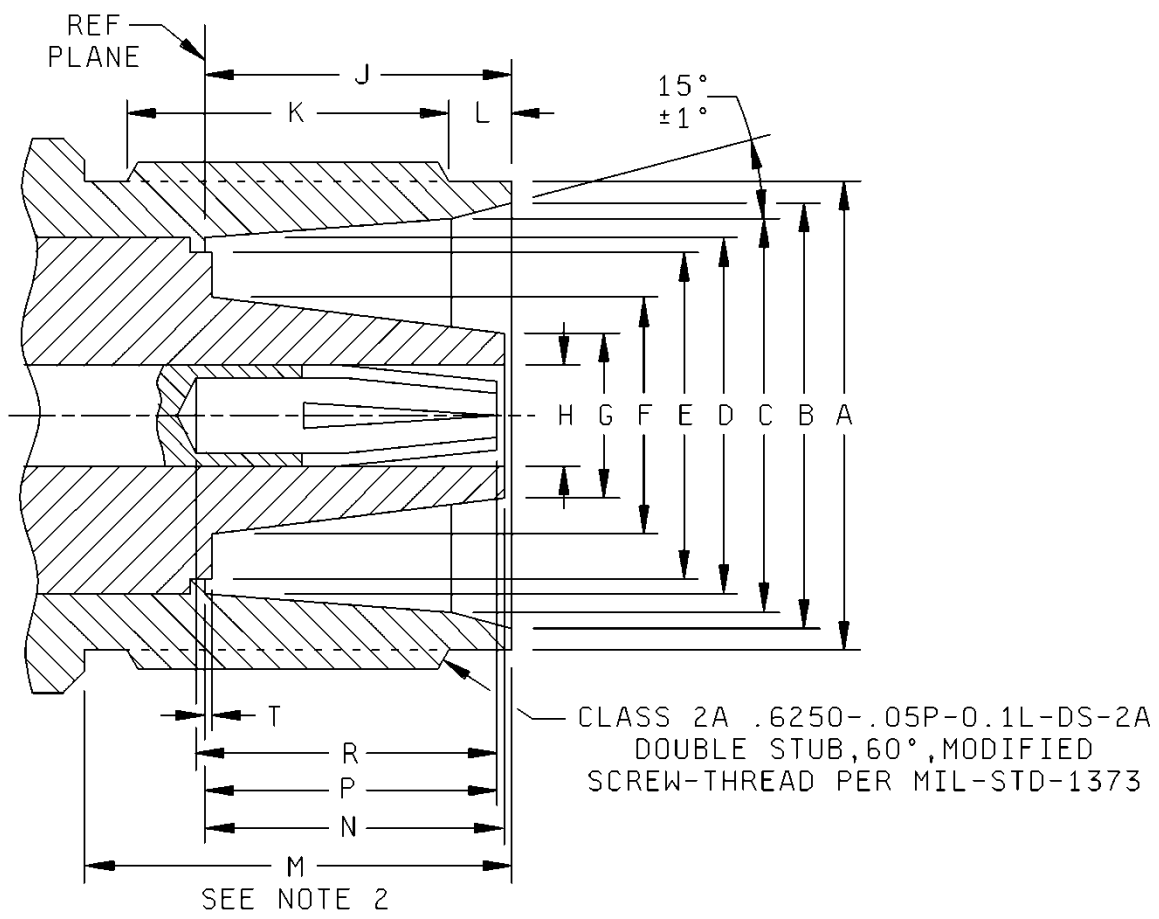

FIGURE 308-2. Interface, series QSC, socket contact.

**MIL-STD-348B
 w/CHANGE 2**

Dim. Ltr.	Inches (mm)	
	Min.	Max.
A	.571 (14.50)	.574 (14.58)
B	.485 (12.32)	.495 (12.57)
C	.440 (11.18)	.450 (11.43)
D	.411 (10.44)	.416 (10.57)
E	-----	.374 (9.50)
F	-----	.272 (6.91)
G	-----	.190 (4.83)
H	.119 (3.02)	.124 (3.15)
J	.332 (8.43)	.338 (8.59)
K	.271 (6.88)	.291 (7.39)
L	.088 (2.24)	.098 (2.49)
M	.495 (12.57)	-----
N	-----	.309 (7.85)
P	-----	.303 (7.70)
R	-----	.325 (8.26)
T	-----	.007 (0.18)

NOTES:

1. This interface shall meet the gauge requirements as specified in MIL-PRF-39012/85.
2. Clearance for mating connector coupling nut.

FIGURE 308-2. Interface, series QSC, socket contact – Continued.

MIL-STD-348B
 w/CHANGE 2

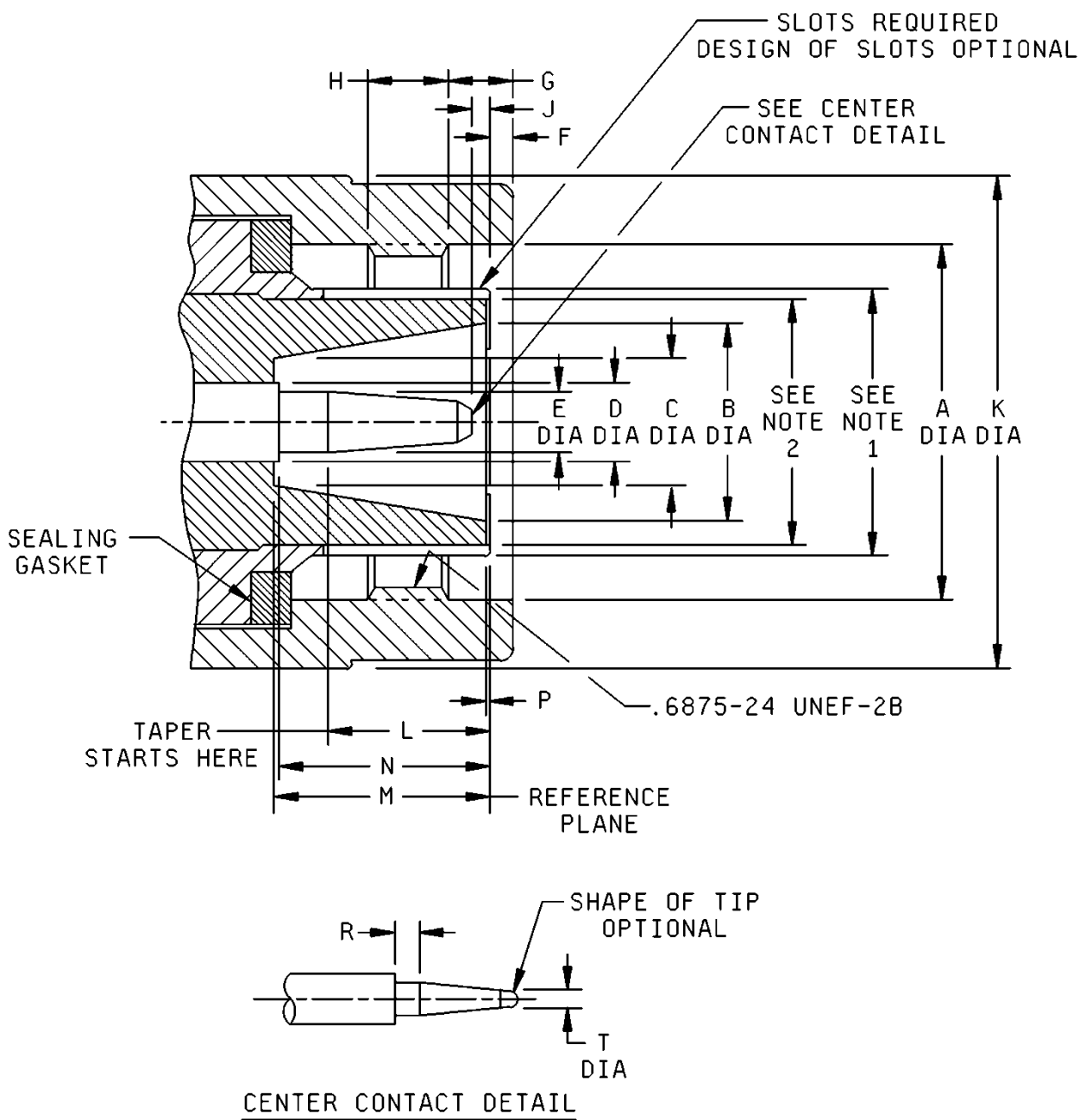

FIGURE 309-1. Interface, series SC, pin contact.

**MIL-STD-348B
 w/CHANGE 2**

Dim. Ltr.	Inches (mm)	
	Min.	Max.
A	.690 (14.99)	-----
B	.276 (7.01)	-----
C	.194 (4.93)	-----
D	.119 (3.02)	.124 (3.15)
E	.090 (2.29)	.092 (2.34)
F	.025 (.64)	.085 (2.16)
G	.213 (5.41)	.223 (5.66)
H	.250 (6.35)	-----
J	.003 (0.08)	.040 (1.02)
K	-----	.828 (21.03)
L	.191 (4.85)	.251 (6.38)
M	.309 (7.85)	-----
N	.307 (7.80)	.337 (8.56)
P	.007 (0.18)	-----
R	.093 (2.36)	-----
T	-----	.050 (1.27)

NOTES:

1. This interface shall be flared to meet gauge requirements as specified in MIL-PRF-39012.
2. The ID of outer contact when inserted into a .411 inch (10.44 mm) maximum ring gauge shall be .377 inch (9.58 mm) minimum.

FIGURE 309-1. Interface, series SC, pin contact - Continued.

MIL-STD-348B
w/CHANGE 2

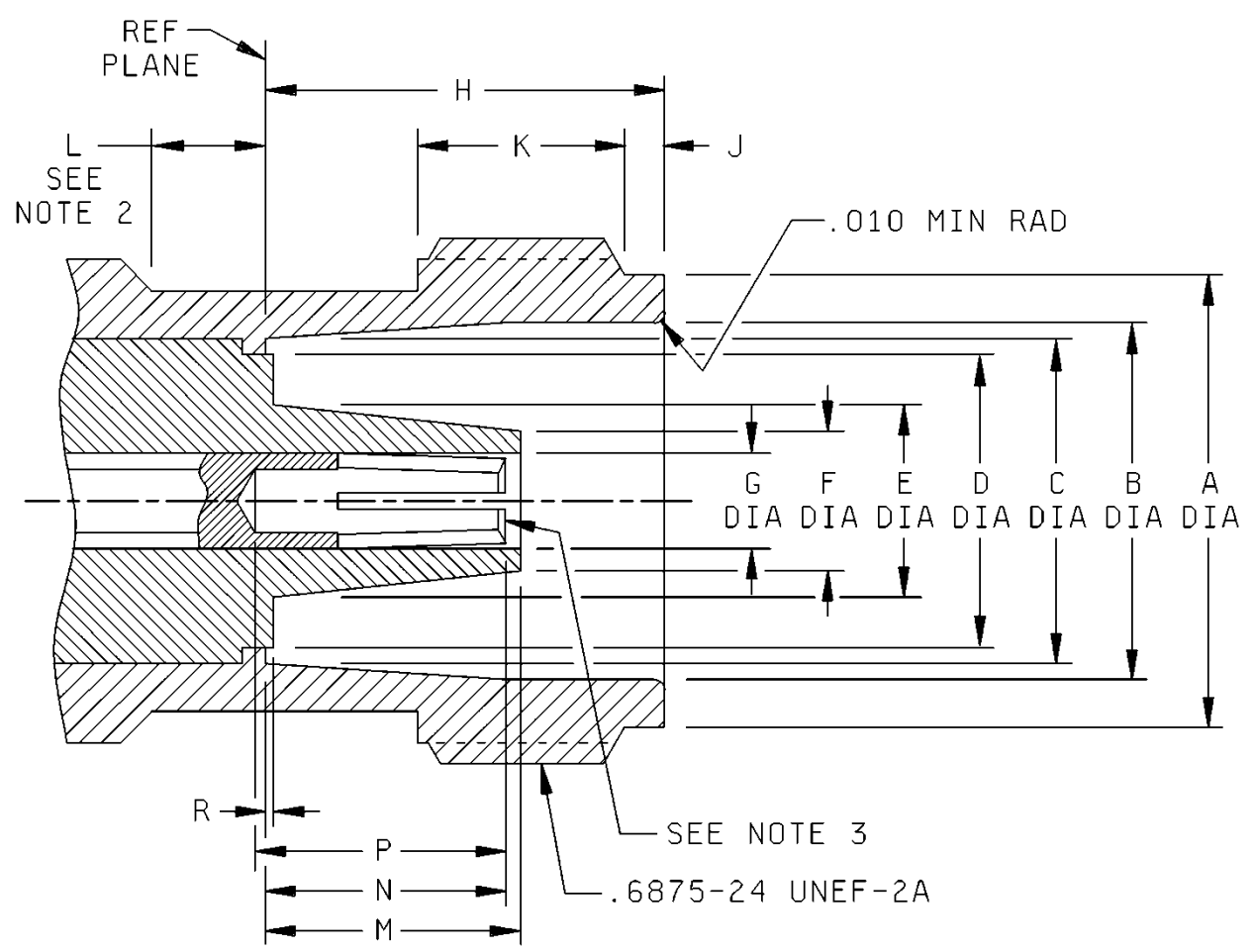

FIGURE 309-2. Interface, series SC, socket contact.

**MIL-STD-348B
 w/CHANGE 2**

Dim. Ltr.	Inches (mm)	
	Min.	Max.
A	-----	.630 (16.00)
B	.482 (12.24)	.498 (12.65)
C	.411 (10.44)	.415 (10.54)
D	-----	.374 (9.50)
E	-----	.272 (6.91)
F	-----	.190 (4.83)
G	.119 (3.02)	.124 (3.15)
H	.491 (12.47)	.495 (12.57)
J	.047 (1.19)	.077 (1.96)
K	.250 (6.35)	-----
L	.140 (3.56)	-----
M	-----	.309 (7.85)
N	.273 (6.93)	.303 (7.70)
P	.300 (7.62)	-----
R	-----	.007 (0.18)

NOTES:

1. This interface shall meet the gauge requirements as specified in MIL-PRF-39012/40.
2. Clearance for mating connector coupling nut.
3. Interface shall meet the mechanical and electrical performance requirements when mated with a .090 (2.29 mm)/.092 (2.34 mm) male pin.

FIGURE 309-2. Interface, series SC, socket contact – Continued.

MIL-STD-348B
 w/CHANGE 2

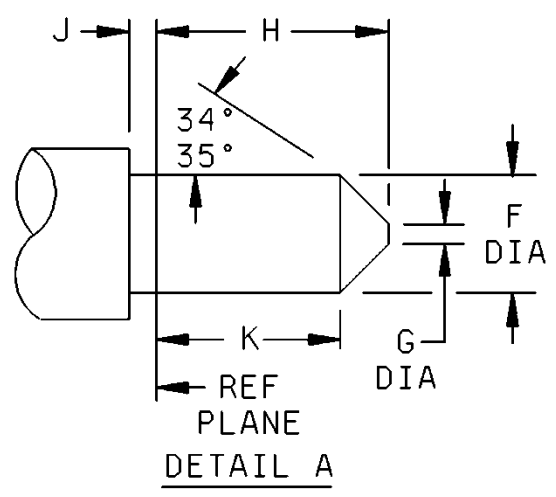
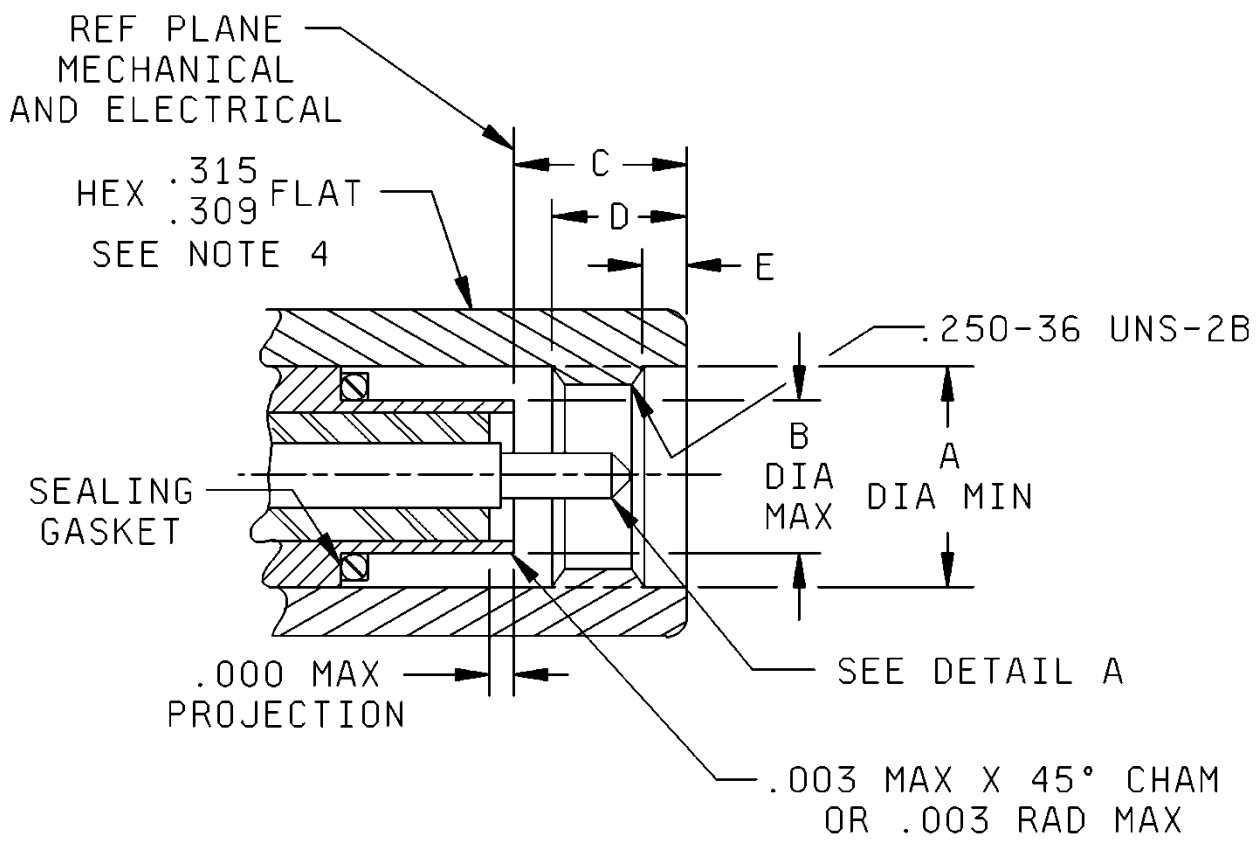

FIGURE 310-1. Interface, series SMA, pin contact.

MIL-STD-348B
 w/CHANGE 2

Dim. Ltr.	Inches (mm)	
	Min.	Max.
A	.255 (6.48)	-----
B	-----	.1808 (4.59)
C	-----	.135 (3.43)
D	.130 (3.30)	-----
E	.015 (0.38)	.045 (1.14)
F	.0355 (0.90)	.0370 (0.94)
G	-----	.012 (0.30)
H	-----	.100 (2.54)
J	.000 (0.00)	-----
K	.050 (1.27)	-----

NOTES:

1. Dimensions are in inches.
2. Metric equivalents are given for information only.
3. Connector interfaces (after mating) shall be kept free from dust and moisture.
4. May extend throughout the full length of the coupling nut.

FIGURE 310-1. Interface, series SMA, pin contact - Continued.

MIL-STD-348B
 w/CHANGE 2

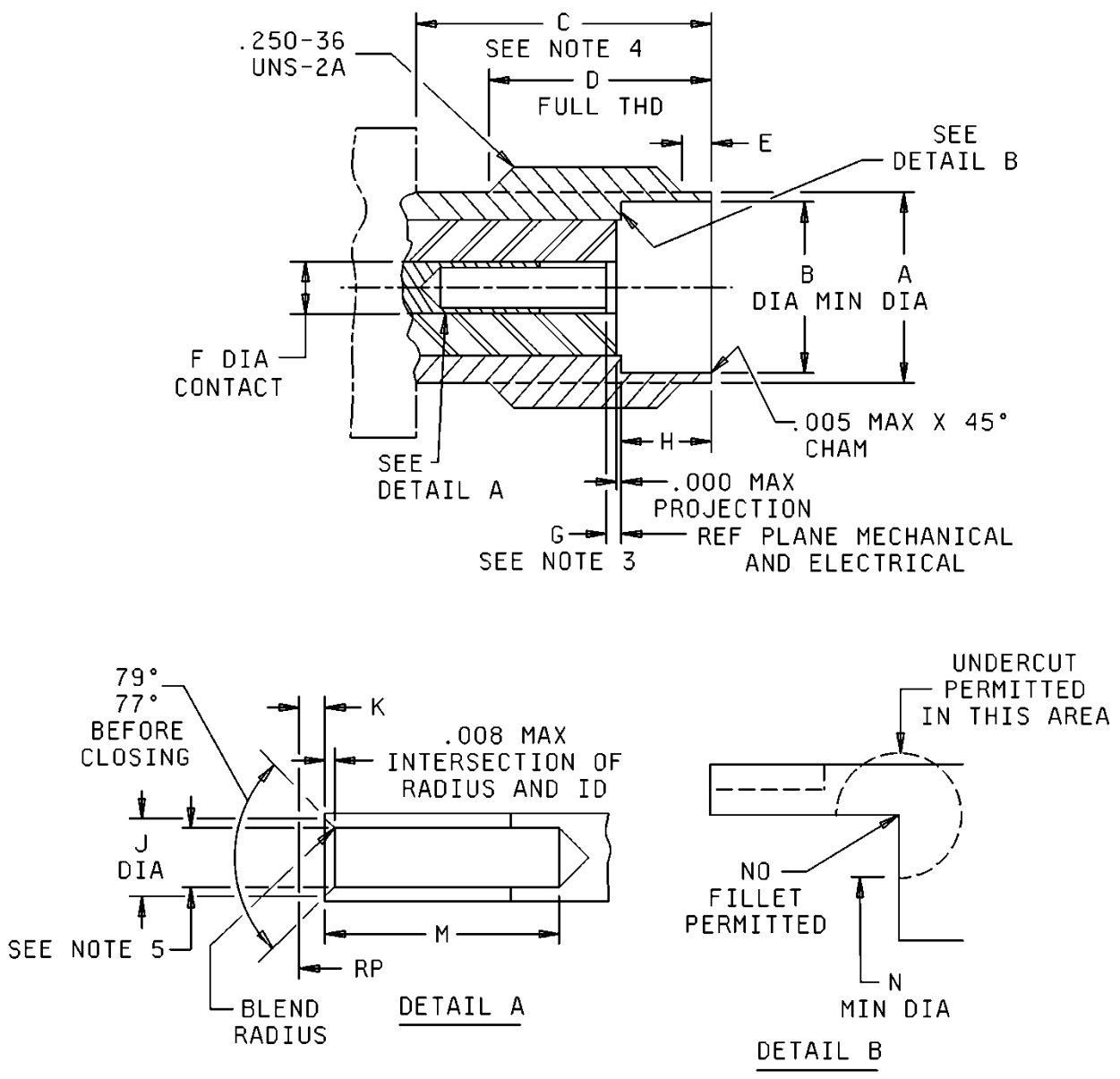

FIGURE 310-2. Interface, series SMA, socket contact.

**MIL-STD-348B
 w/CHANGE 2**

Dim. Ltr.	Inches (mm)	
	Min.	Max.
A	.208 (5.28)	.216 (5.49)
B	.1810 (4.60)	-----
C	.218 (5.54)	-----
D	.170 (4.32)	-----
E	.015 (0.38)	.045 (1.14)
F	.049 (1.24)	.051 (1.30)
G	.000 (0.00)	.010 (0.25)
H	.074 (1.88)	.078 (1.98)
J	.043 (1.09)	.047 (1.19)
K	.000 (0.00)	.010 (0.25)
M	.105 (2.67)	-----
N	.168 (4.27)	-----

NOTES:

1. Dimensions are in inches.
2. Metric equivalents are for information only.
3. Previously qualified parts using a .030 inch (0.76) maximum contact recession are not acceptable for Government use. Caution should be exercised to determine whether a .030 recession design is being used during maintenance and part replacement.
4. Clearance for mating connector coupling nut.
5. Dimension to meet VSWR, mating characteristics, and connector durability when mated with a +.0355/-.0370 inch diameter pin.

FIGURE 310-2. Interface, series SMA, socket contact - Continued.

**MIL-STD-348B
 w/CHANGE 2**

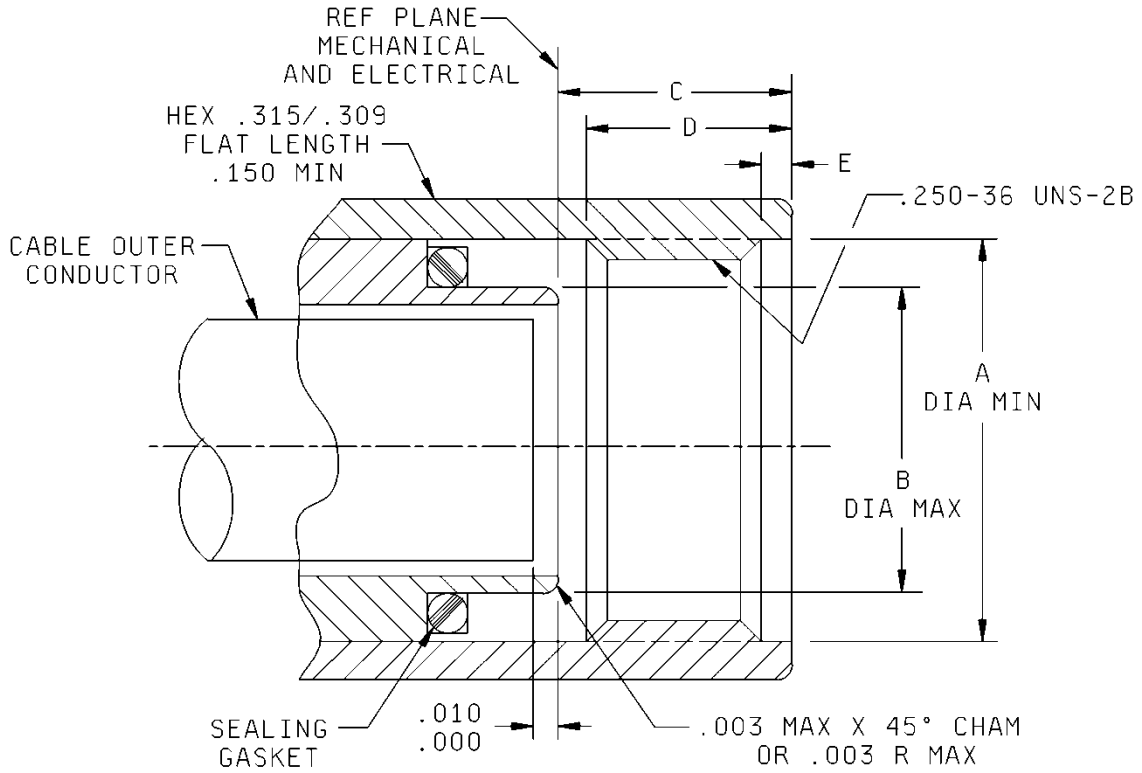

Dim. Ltr.	Inches (mm)	
	Min.	Max.
A	.255 (6.48)	-----
B	-----	.1808 (4.59)
C	-----	.135 (3.43)
D	.130 (3.30)	-----
E	.015 (0.38)	.045 (1.14)

NOTES:

1. Dimensions are in inches.
2. Metric equivalents are given for information only.
3. Reference MIL-PRF-39012/92 for cable stripping dimensions.

FIGURE 310-3. Interface, series SMA, no contact.

MIL-STD-348B
w/CHANGE 2

INTERFACE DIMENSIONS TO BE ESTABLISHED

FIGURE 310-4. Interface, series SMA, .036 contact.

**MIL-STD-348B
 w/CHANGE 2**

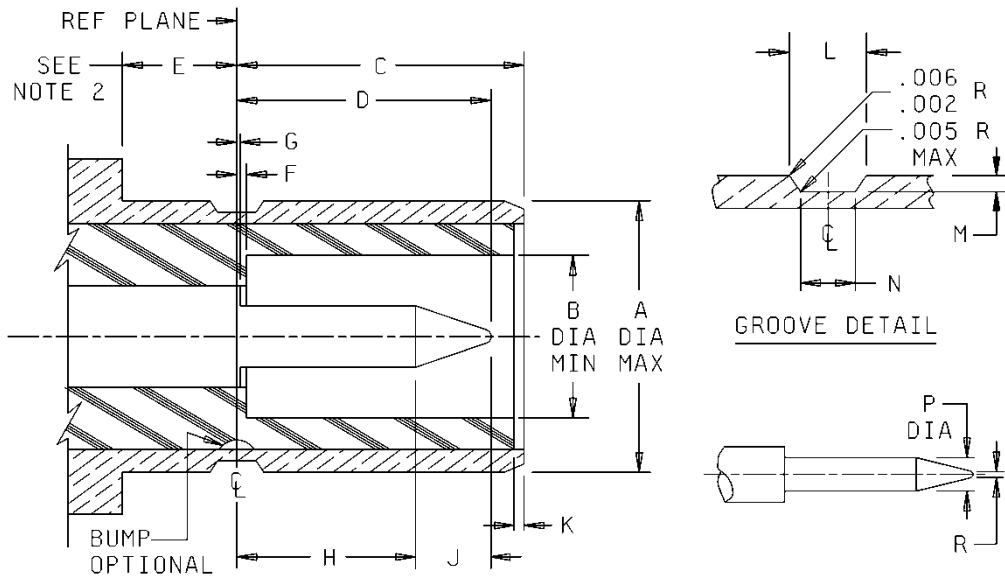

Dim. Ltr.	Inches (mm)	
	Min.	Max.
A	-----	.146 (3.71)
B	.082 (2.08)	-----
C	.131 (3.33)	.141 (3.58)
D	.094 (2.39)	.117 (2.97)
E	.065 (1.65)	-----
F	-----	.007 (0.18)
G	-----	.007 (0.18)
H	.052 (1.32)	-----
J	.010 (0.25)	-----
K	.000 (0.00)	-----
L	.027 (0.69)	.037 (0.94)
M	.006 (0.15)	.010 (0.25)
N	.011 (0.28)	.015 (0.38)
P	.019 (0.48)	.021 (0.53)
R	-----	.010 (0.25)

NOTES:

1. This interface shall meet the gauge requirements as specified in MIL-PRF-39012/68.
2. Clearance for mating connector coupling nut.

FIGURE 311-1. Interface, series SMB, pin contact.

MIL-STD-348B
 w/CHANGE 2

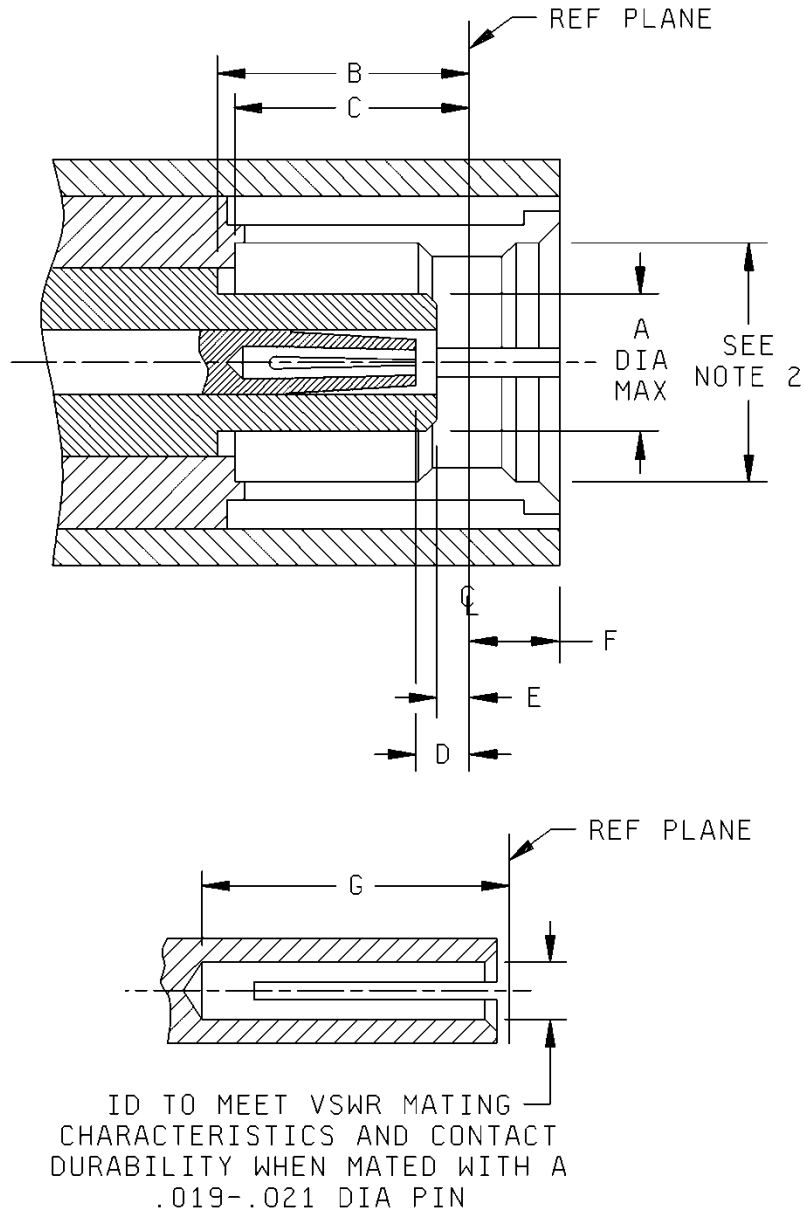

FIGURE 311-2. Interface, series SMB, socket contact.

MIL-STD-348B
 w/CHANGE 2

Dim. Ltr.	Inches (mm)	
	Min.	Max.
A	-----	.081 (2.06)
B	.141 (3.58)	-----
C	.141 (3.58)	-----
D	.007 (0.18)	.037 (0.94)
E	.007 (0.18)	-----
F	-----	.064 (1.63)
G	.117 (2.97)	-----

NOTES:

1. Method of slotting of inner contact optional.
2. Must meet the longitudinal force requirements of force to engage and disengage when mated with its mating gauge.
3. This interface shall meet the gauge requirements as specified in MIL-PRF-39012/67.

FIGURE 311-2. Interface, series SMB, socket contact - Continued.

MIL-STD-348B
w/CHANGE 2

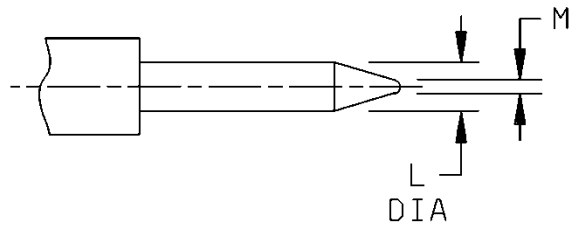
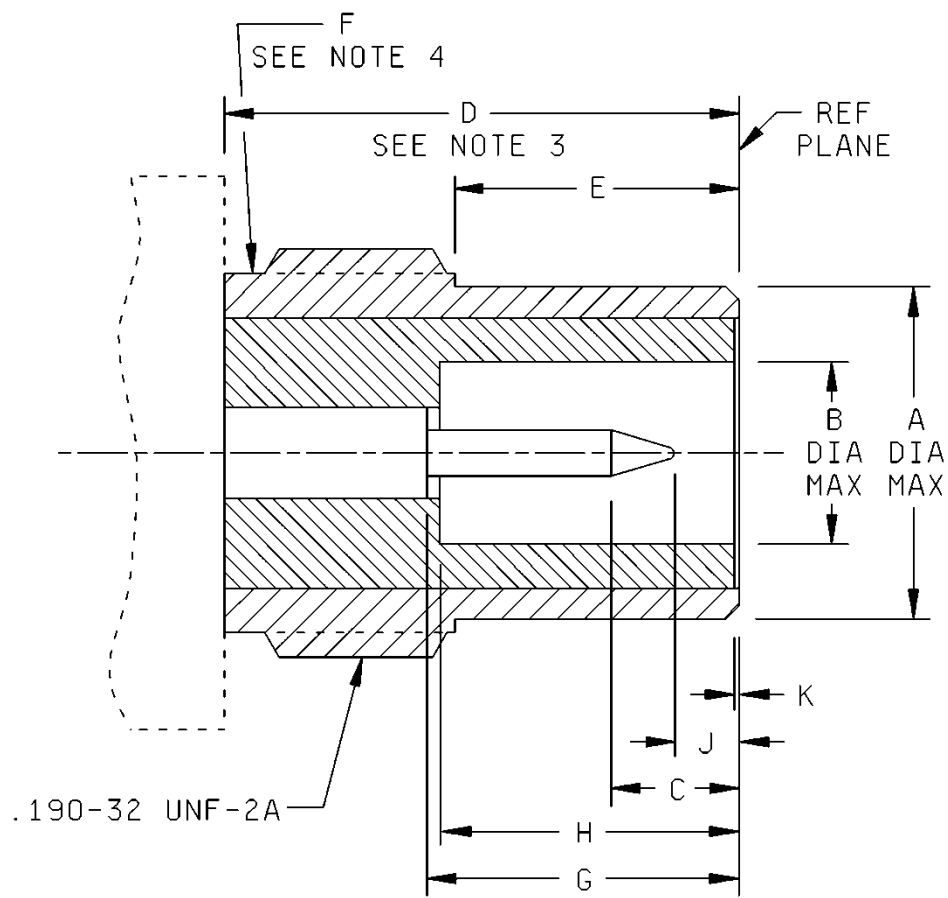

FIGURE 312-1. Interface, series SMC, pin contact.

**MIL-STD-348B
 w/CHANGE 2**

Dim. Ltr.	Inches (mm)	
	Min.	Max.
A	-----	.146 (3.71)
B	.082 (2.08)	-----
C	-----	.084 (2.13)
D	.234 (5.94)	-----
E	.123 (3.12)	.133 (3.38)
F	-----	.040 (1.02)
G	.134 (3.40)	-----
H	.134 (3.40)	-----
J	.024 (0.61)	-----
K	.000 (0.00)	-----
L	.019 (0.48)	.021 (0.53)
M	-----	.010 (0.25)

NOTES:

1. This interface shall meet the gauge requirements as specified in MIL-PRF-39012/74.
2. Thread gauge must go .234 inch minimum from reference plane.
3. Clearance for mating connector coupling nut.
4. With undercut to root diameter.

FIGURE 312-1. Interface, series SMC, pin contact – Continued.

MIL-STD-348B
 w/CHANGE 2

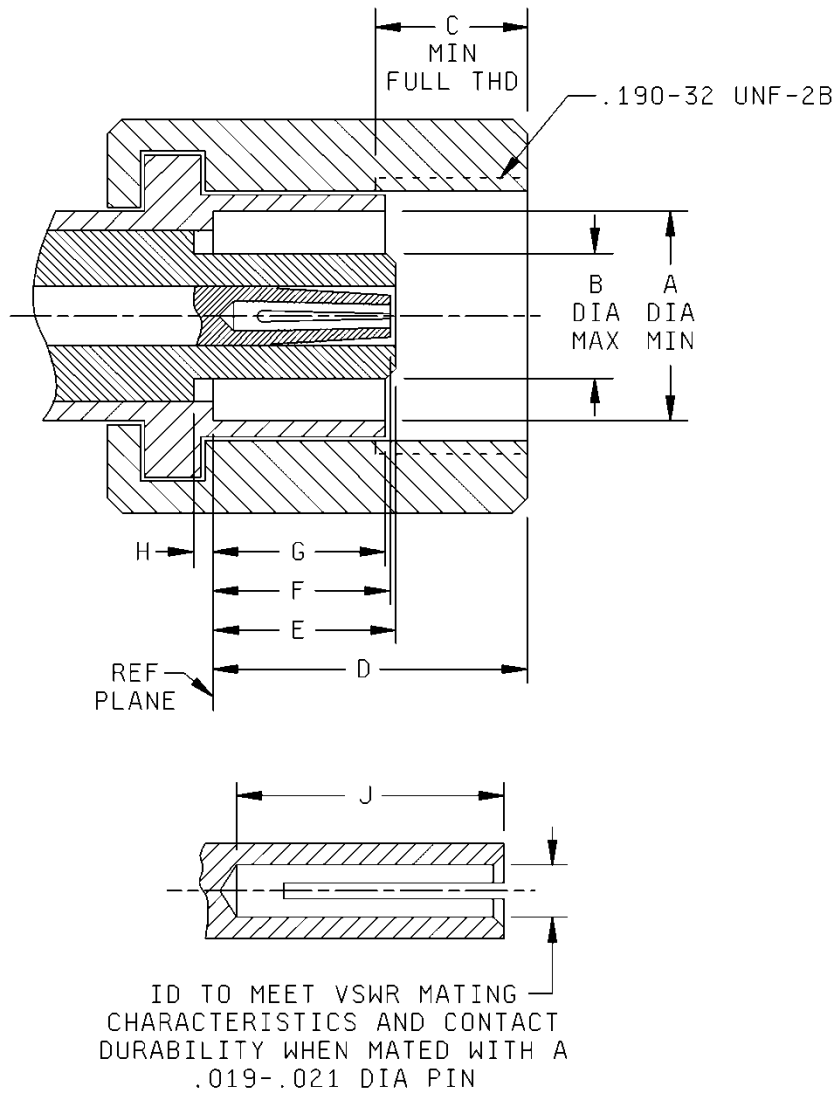

FIGURE 312-2. Interface, series SMC, socket contact.

MIL-STD-348B
 w/CHANGE 2

Dim. Ltr.	Inches (mm)	
	Min.	Max.
A	.147 (3.73)	-----
B	-----	.081 (2.06)
C	.110 (2.79)	-----
D	-----	.233 (5.92)
E	-----	.134 (3.40)
F	-----	.134 (3.40)
G	-----	.122 (3.10)
H	.000 (0.00)	-----
J	.110 (2.79)	-----

NOTES:

1. Method of slotting of inner contact optional.
2. This interface shall meet the gauge requirements as specified in MIL-PRF-39012/73.

FIGURE 312-2. Interface, series SMC, socket contact – Continued.

MIL-STD-348B
 w/CHANGE 2

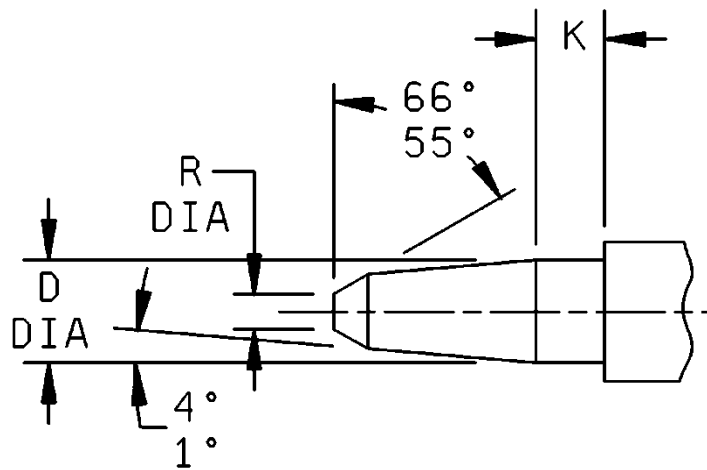
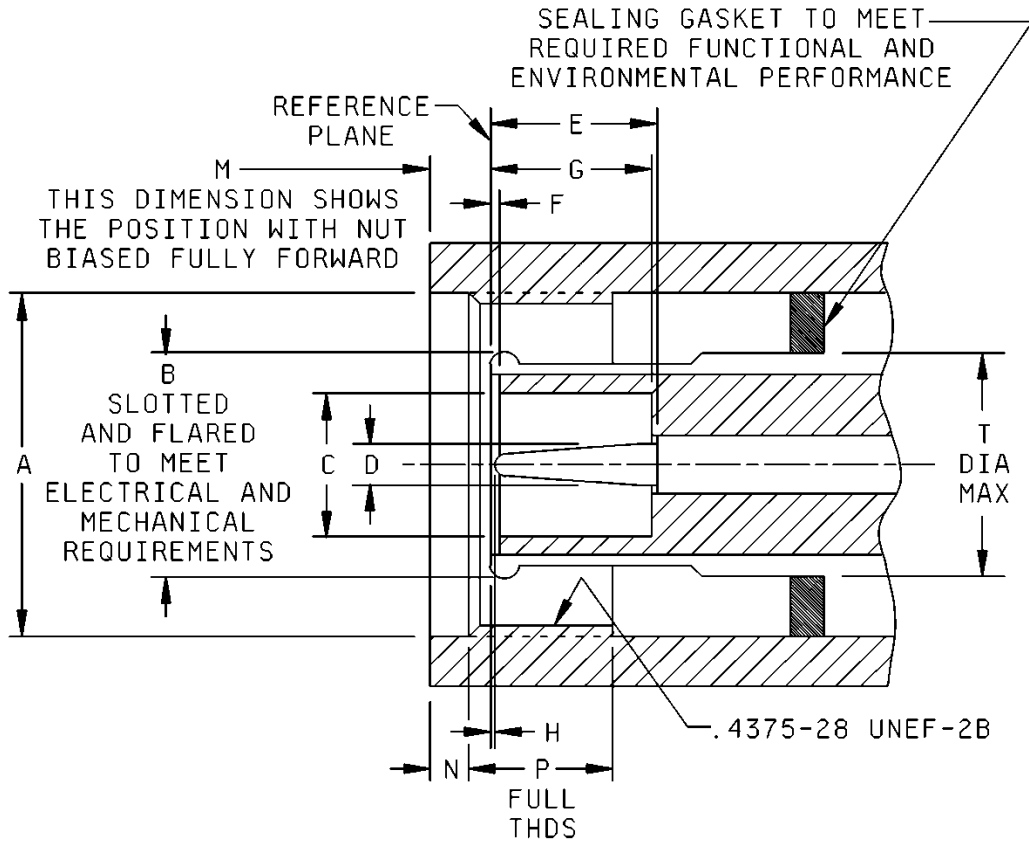

FIGURE 313-1. Interface, series TNC, pin contact.

**MIL-STD-348B
 w/CHANGE 2**

Dim. Ltr.	Inches (mm)	
	Min.	Max.
A	.440 (11.18)	-----
B	Gauge test	
C	.190 (4.83)	-----
D	.052 (1.32)	.054 (1.37)
E	.210 (5.33)	.230 (5.84)
F	.006 (0.15)	-----
G	.208 (5.28)	.228 (5.79)
H	.003 (0.08)	.040 (1.02)
K	.078 (1.98)	-----
M	-----	.078 (1.98)
N	.063 (1.60)	-----
P	.156 (3.96)	-----
R	-----	.025 (0.64)
T	-----	.322 (8.18)

NOTE:

1. This interface shall meet the gauge requirements as specified in MIL-PRF-39012/26.

FIGURE 313-1. Interface, series TNC, pin contact – Continued.

MIL-STD-348B
 w/CHANGE 2

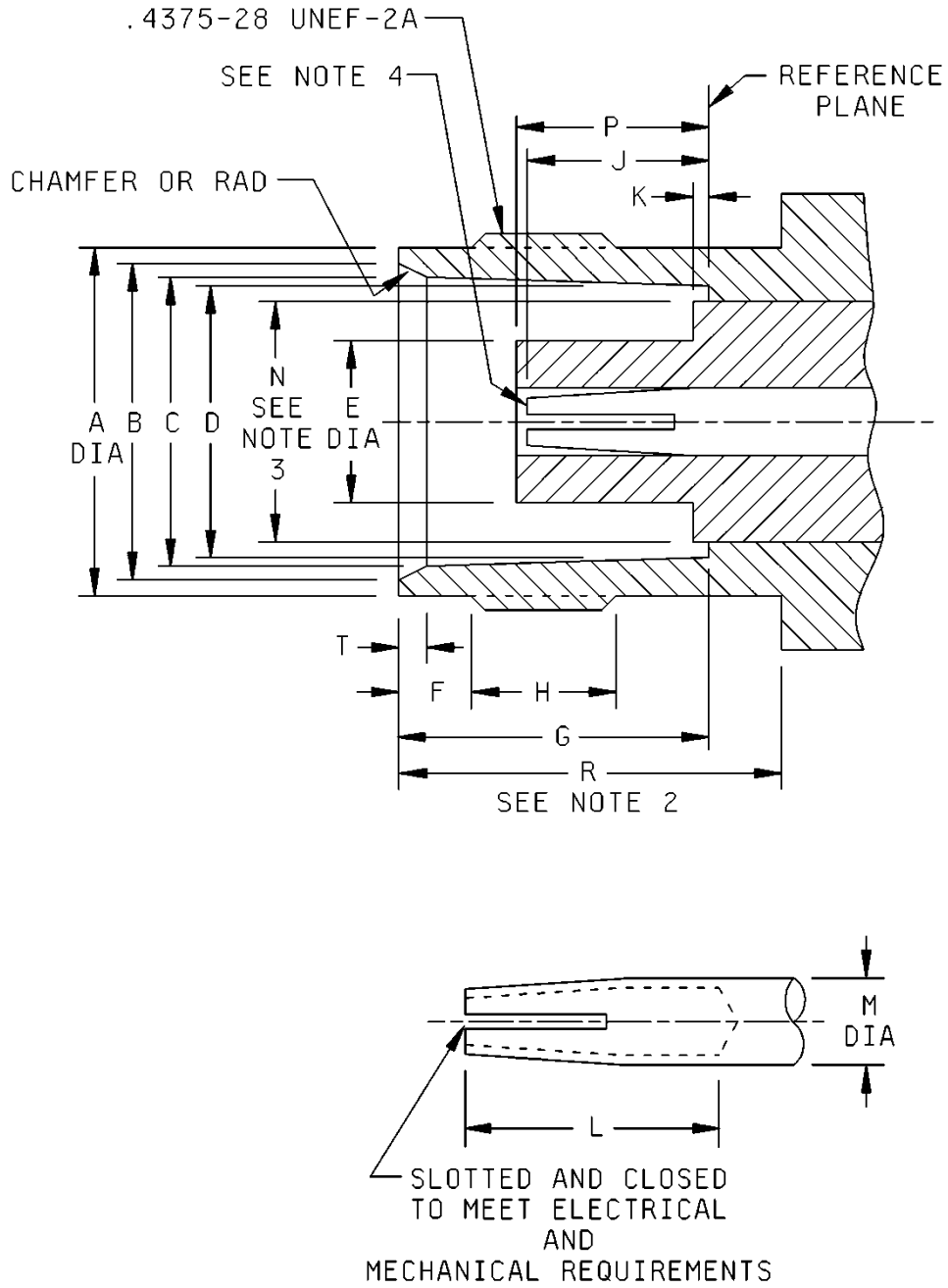

FIGURE 313-2. Interface, series TNC, socket contact.

MIL-STD-348B
 w/CHANGE 2

Dim. Ltr.	Inches (mm)	
	Min.	Max.
A	.378 (9.60)	.381 (9.68)
B	.346 (8.79)	.356 (9.04)
C	.327 (8.31)	.333 (8.46)
D	.319 (8.10)	.321 (8.15)
E	-----	.186 (4.72)
F	.068 (1.73)	.088 (2.24)
G	.327 (8.31)	.335 (8.51)
H	.187 (4.75)	-----
J	.186 (4.72)	.206 (5.23)
K	-----	.006 (0.15)
L	.195 (4.95)	-----
M	.081 (2.06)	.087 (2.21)
N	-----	.256 (6.50)
P	.188 (4.78)	.208 (5.28)
R	.414 (10.52)	-----
T	.015 (0.38)	.030 (0.76)

NOTES:

1. This interface shall meet the gauge requirements as specified in MIL-PRF-39012/28.
2. Clearance for mating connector coupling nut.
3. Dimension applies to that portion (if applicable) of the dielectric which protrudes beyond the metal shoulder (or reference plane) by dimension K.
4. ID to meet VSWR when mated with .052 inch (1.32 mm)/.054 (1.37 mm) diameter pin.

FIGURE 313-2. Interface, series TNC, socket contact – Continued.

MIL-STD-348B
 w/CHANGE 2

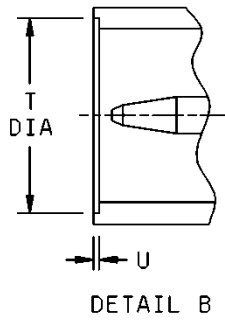
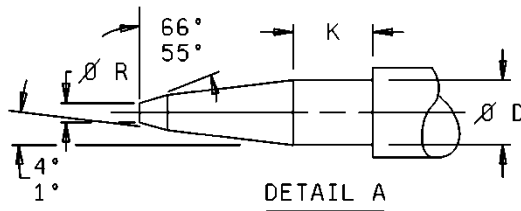
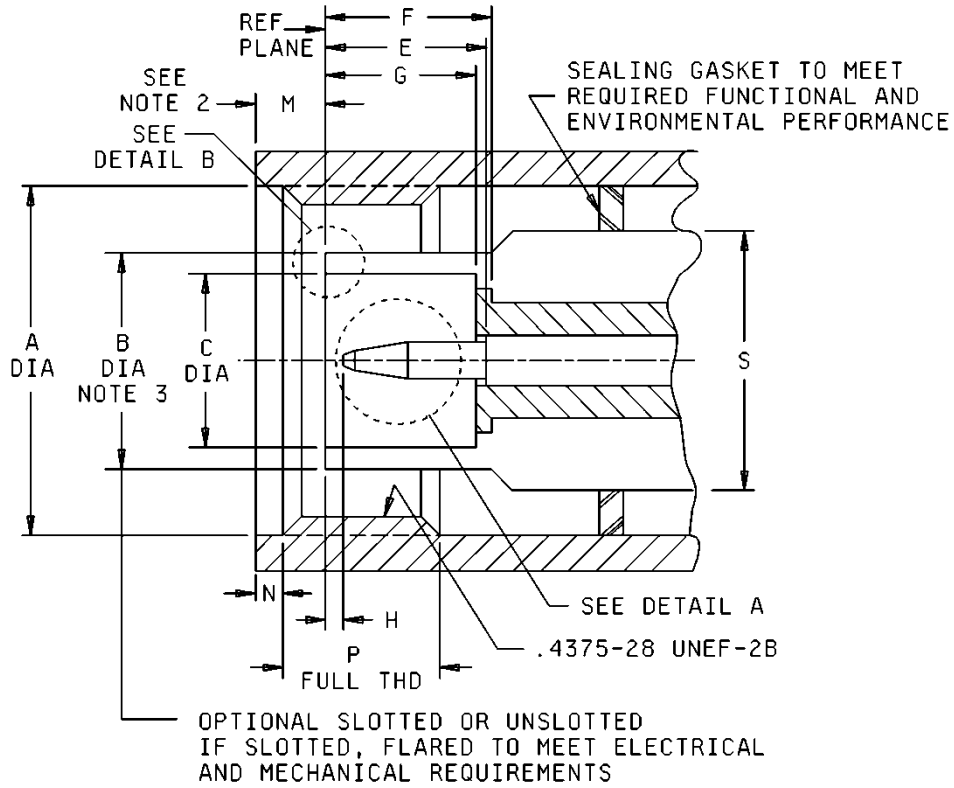

OPTIONAL UNSLOTTED
 WITH COUNTERBORE

FIGURE 313-3. Interface, series TNCA, pin contact, air interface.

**MIL-STD-348B
 w/CHANGE 2**

Dim. Ltr.	Inches (mm)	
	Min.	Max.
A	.440 (11.18)	-----
B	.314 (7.98)	.318 (8.08)
C	.238 (6.05)	.242 (6.15)
D	.052 (1.32)	.054 (1.37)
E	.208 (5.28)	-----
F	.212 (5.38)	-----
G	.208 (5.28)	-----
H	.003 (0.08)	.040 (1.02)
K	.078 (1.98)	-----
M	-----	.078 (1.98)
N	.063 (1.60)	-----
P	.156 (3.96)	-----
R	-----	.025 (0.64)
S	-----	.322 (8.18)
T	.275 (6.98)	.277 (7.03)
U	.0060 (0.152)	.0090 (0.229)

NOTES:

1. Three holes .027 inch (0.69) minimum diameter equally spaced for safety wiring when required. Location on coupling nut is optional.
2. Dimension with nut bias fully forward.
3. B dimension applies to unslotted version. Slotted designs must meet gauge test, B dimension will not apply.

FIGURE 313-3. Interface, series TNCA, pin contact, air interface – Continued.

MIL-STD-348B
 w/CHANGE 2

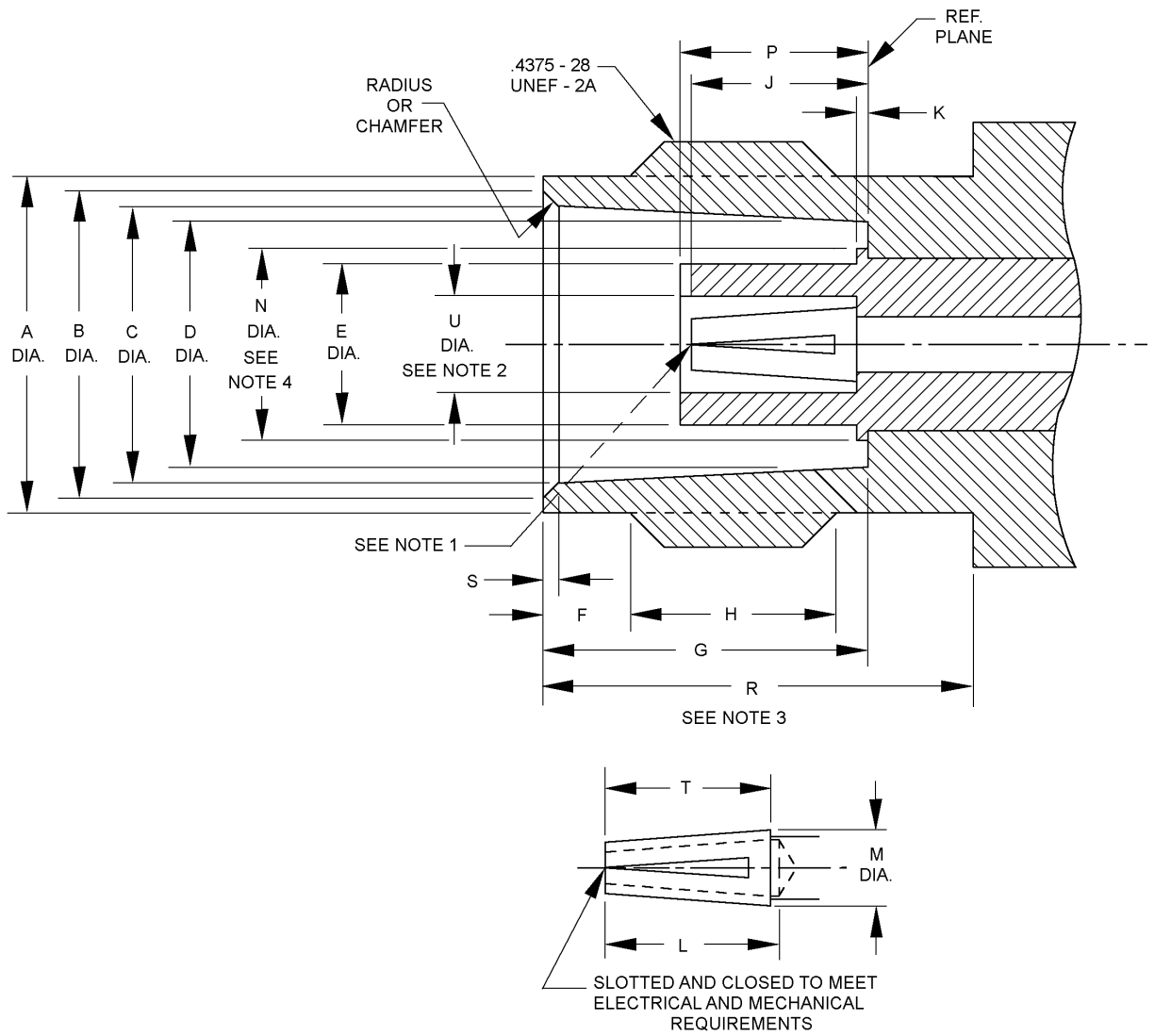

FIGURE 313-4. Interface, series TNCA, socket contact, air interface.

**MIL-STD-348B
 w/CHANGE 2**

Dim. Ltr.	Inches (mm)	
	Min.	Max.
A	.378 (9.60)	.381 (9.68)
B	.346 (8.79)	.356 (9.04)
C	.327 (8.31)	.333 (8.38)
D	.319 (8.10)	.321 (8.15)
E	.182 (4.62)	.186 (4.72)
F	.068 (1.73)	.088 (2.24)
G	.327 (8.31)	.335 (8.51)
H	.187 (4.75)	-----
J	.198 (5.03)	.208 (5.28)
K	-----	.006 (0.15)
L	.195 (4.95)	-----
M	.084 (2.13)	.087 (2.21)
N	-----	.230 (5.84)
P	.198 (5.03)	.208 (5.28)
R	.414 (10.52)	-----
S	.015 (0.38)	.030 (0.76)
T	.180 (4.57)	.196 (4.98)
U	-----	.092 (2.34)

NOTES:

1. ID to meet VSWR when mated with .052 (1.32 mm) .054 (1.37 mm) diameter pin.
2. Diameter is ID of dielectric.
3. Clearance for mating connector coupling nut.
4. Applies to portion of dielectric which protrudes beyond metal shoulder (reference plane).

FIGURE 313-4. Interface, series TNCA, socket contact, air interface – Continued.

MIL-STD-348B
w/CHANGE 2

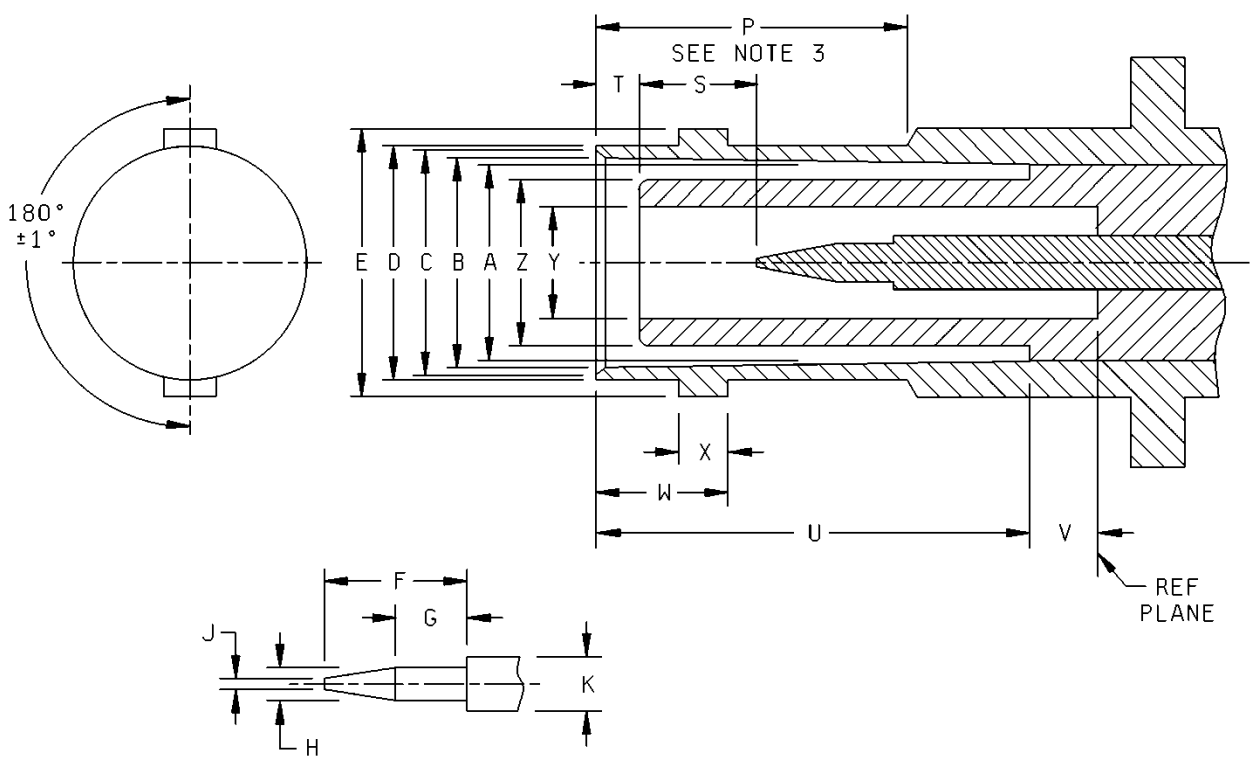

FIGURE 314-1. Interface, series SHV, pin contact.

MIL-STD-348B
 w/CHANGE 2

Dim. Ltr.	Inches (mm)	
	Min.	Max.
A	.319 (8.10)	.321 (8.15)
B	.328 (8.33)	.333 (8.46)
C	.347 (8.81)	.357 (9.07)
D	.378 (9.60)	.382 (9.70)
E	.432 (10.97)	.436 (11.07)
F	.207 (5.26)	.214 (5.44)
G	.130 (3.30)	-----
H	.052 (1.32)	.054 (1.37)
J	.015 (0.38)	.025 (0.64)
K	.081 (2.06)	.083 (2.11)
P	.427 (10.85)	-----
S	.188 (4.78)	.208 (5.28)
T	.061 (1.55)	.078 (1.98)
U	.626 (15.90)	.630 (16.00)
V	.064 (1.63)	.086 (2.18)
W	.204 (5.18)	.208 (5.28)
X	.075 (1.91)	.081 (2.06)
Y	.190 (4.83)	.196 (4.98)
Z	-----	.260 (6.60)

NOTES:

1. This interface shall meet the gauge requirements as specified in MIL-PRF-39012/107.
2. .005 inch (0.13 mm) flat permissible to meet dimension W.
3. Clearance for meeting connector coupling nut.

FIGURE 314-1. Interface, series SHV, pin contact – Continued.

MIL-STD-348B
 w/CHANGE 2

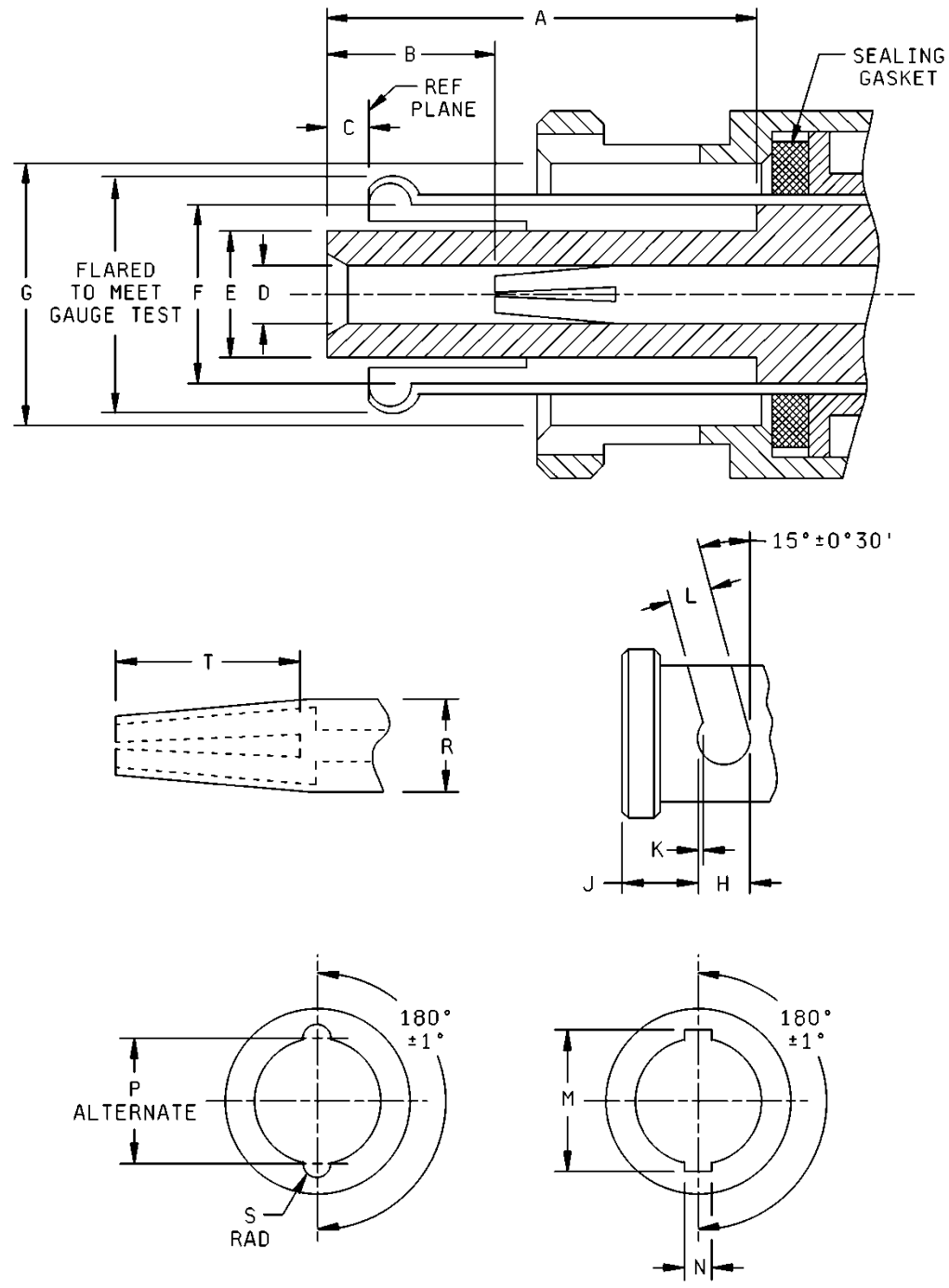

FIGURE 314-2. Interface, series SHV, socket contact.

**MIL-STD-348B
 w/CHANGE 2**

Dimension Ltr.	Inches (mm)	
	Minimum	Maximum
A	.628 (15.95)	.632 (16.05)
B	.238 (6.05)	.262 (6.65)
C	.046 (1.17)	.064 (1.63)
D	.082 (2.08)	-----
E	.180 (4.57)	.186 (4.72)
F	.264 (6.71)	-----
G	.385 (9.78)	.390 (9.91)
H	.124 (3.15)	-----
J	.180 (4.57)	.184 (4.67)
K	.018 (0.46)	.022 (0.56)
L	.091 (2.31)	.097 (2.46)
M	.463 (11.76)	.473 (12.01)
N	.091 (2.31)	.094 (2.39)
P	.394 (10.01)	.400 (10.16)
R	.081 (2.06)	.083 (2.11)
S	.045 (1.14)	.049 (1.24)
T	.214 (5.44)	-----

NOTE: This interface shall meet the gauge requirements as specified MIL-PRF-39012/106.

FIGURE 314-2. Interface, series SHV, socket contact – Continued.

MIL-STD-348B
w/CHANGE 2

INTERFACE DIMENSIONS FOR MIL-DTL-3650

(To be established)

FIGURE 315-1. Interface, series LC, pin contact.

MIL-STD-348B
w/CHANGE 2

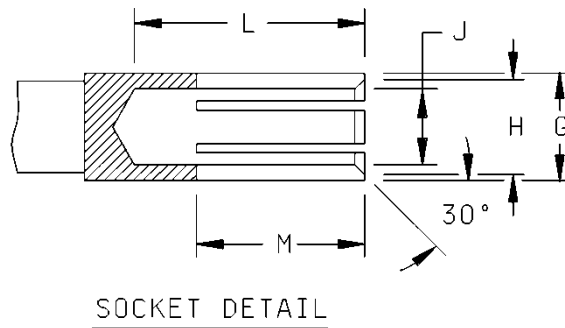
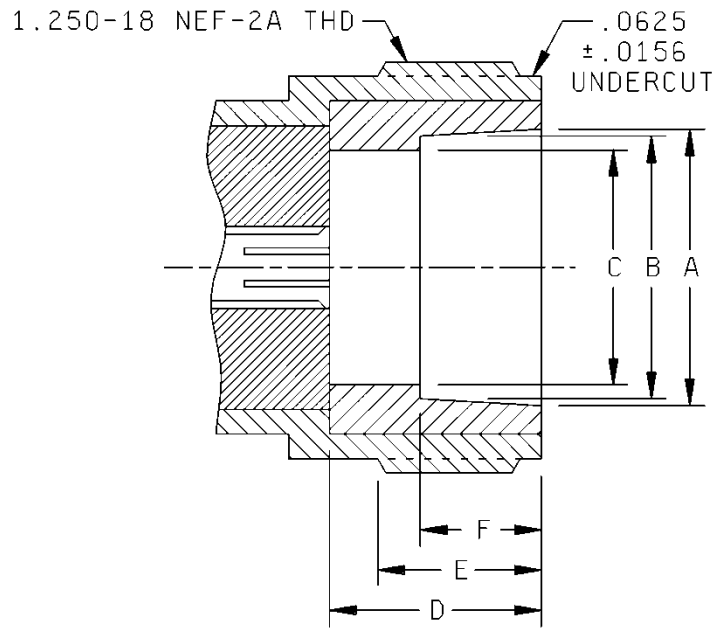

FIGURE 315-2. Interface, series LC, socket contact, full dielectric.

**MIL-STD-348B
 w/CHANGE 2**

Dimension Ltr.	Inches (mm)	
	Minimum	Maximum
A	.806 (20.47)	.814 (20.68)
B	.788 (20.02)	.790 (19.81)
C	.693 (17.60)	.697 (17.70)
D	.623 (15.82)	.627 (15.93)
E	.484 (12.29)	.516 (13.11)
F	.373 (9.47)	.377 (9.58)
G	.227 (5.77)	.229 (5.82)
H	.212 (5.38)	.220 (5.59)
J	.202 (5.13)	-----
L	.557 (14.15)	-----
M	.250 (6.35)	-----

NOTE. Dimensions J and M to be slotted to meet mechanical and electrical performance requirements.

NOTES:

1. Dimensions are in inches.
2. Metric equivalents are given for information only.
3. This interface shall meet the gauge requirements as specified in MIL-DTL-3650.

FIGURE 315-2. Interface, series LC, socket contact, full dielectric – Continued.

MIL-STD-348B
w/CHANGE 2

INTERFACE DIMENSIONS TO BE ESTABLISHED

FIGURE 315-3. Interface, series LC, pin contact.

MIL-STD-348B
w/CHANGE 2

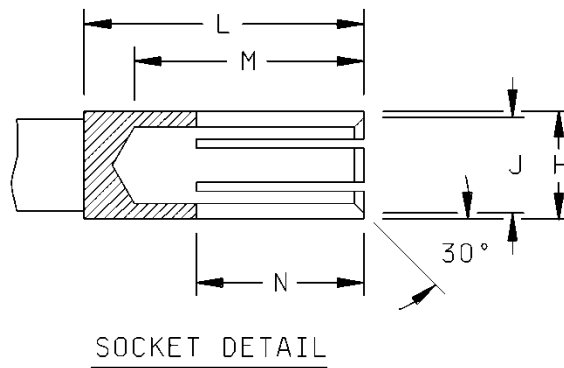
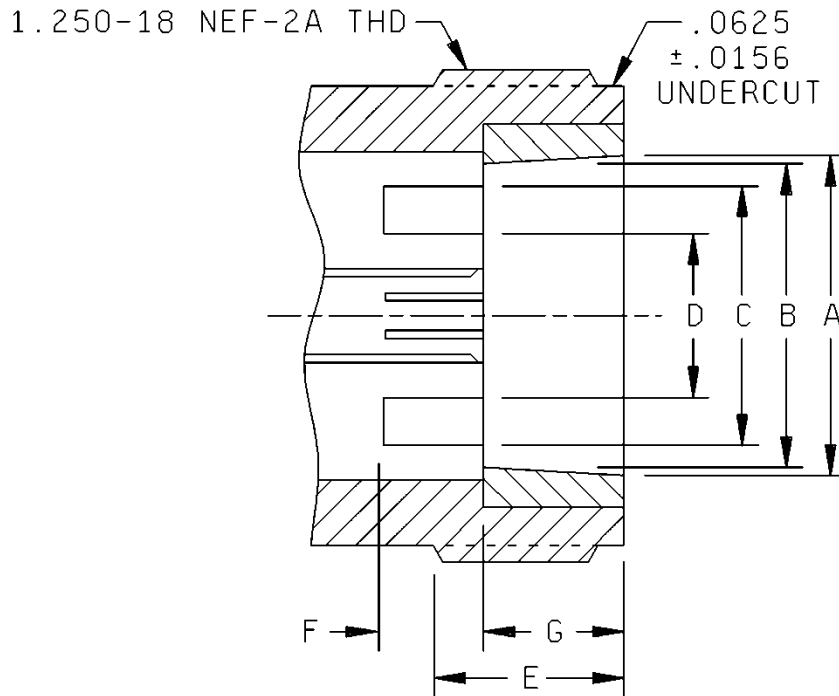

FIGURE 315-4. Interface, series LC, socket contact.

MIL-STD-348B
 w/CHANGE 2

Dimension Ltr.	Inches (mm)	
	Minimum	Maximum
A	.806 (20.47)	.814 (20.68)
B	.788 (20.02)	.790 (20.07)
C	.691 (17.55)	.699 (17.75)
D	.433 (11.00)	.441 (11.20)
E	.484 (12.34)	.516 (13.11)
F	.248 (6.30)	.252 (6.40)
G	.373 (9.47)	.377 (9.58)
H	.227 (5.77)	.229 (5.82)
J	.212 (5.38)	.220 (5.59)
L	.750 (19.05)	-----
M	.557 (14.15)	-----
N	.250 (6.35)	-----

NOTE. Dimensions J and M contact to be slotted to meet mechanical and electrical performance requirements.

NOTES:

1. Dimensions are in inches.
2. Metric equivalents are given for information only.
3. This interface shall meet the gauge requirements of MIL-DTL-3650.

FIGURE 315-4. Interface, series LC, socket contact – Continued.

MIL-STD-348B
w/CHANGE 2

INTERFACE DIMENSIONS FOR MIL-DTL-3650

To be established

FIGURE 315-5. Interface, Series LC, Pin Contact.

MIL-STD-348B
 w/CHANGE 2

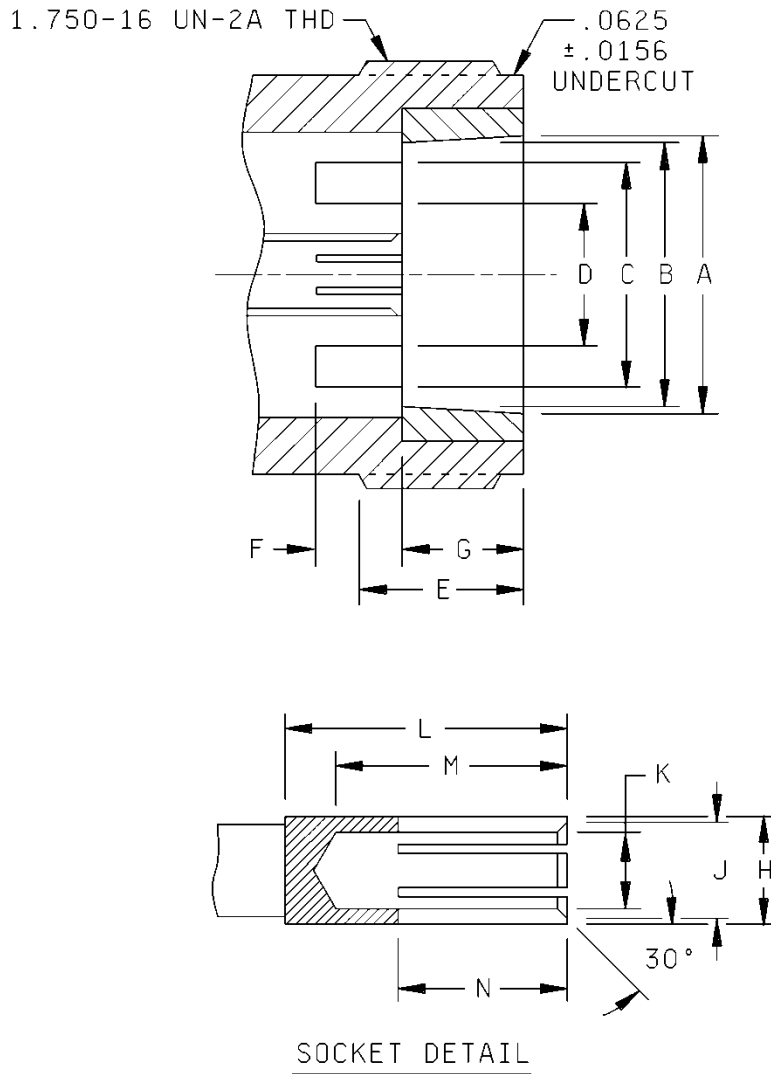

NOTES:

1. Dimensions are in inches.
2. Metric equivalents are for reference purposes only.
3. The interface shall meet the gauge requirements as specified in MIL-DTL-3650.

FIGURE 315-6. Interface, Series LC, Socket Contact.

**MIL-STD-348B
 w/CHANGE 2**

Dimension Ltr.	Inches (mm)	
	Minimum	Maximum
A	1.083 (27.51)	1.093 (27.76)
B	1.054 (26.77)	1.056 (26.82)
C	.926 (23.52)	.934 (23.72)
D	.621 (15.77)	.629 (15.98)
E	.609 (15.47)	.641 (16.28)
F	.373 (9.47)	.377 (9.57)
G	.373 (9.47)	.377 (9.57)
H	.304 (7.72)	.306 (7.77)
J	.289 (7.34)	.297 (7.54)
K	.271 (6.88)	
L	.750 (19.05)	
M	.562 (14.27)	
N	.250 (6.35)	

FIGURE 315-6. Interface, Series LC, Socket Contact – Continued.

MIL-STD-348B
 w/CHANGE 2

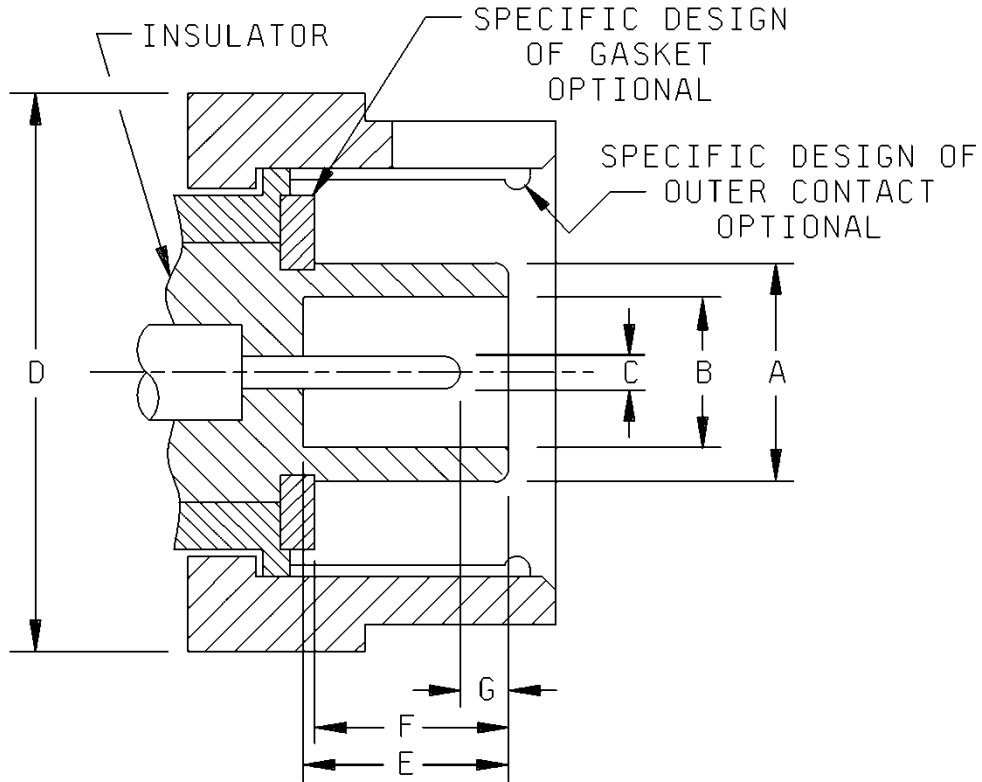

PLUG WITH PIN CONTACT

Dimension Ltr.	Inches (mm)	
	Minimum	Maximum
A	-----	.196 (4.98)
B	.130 (3.30)	-----
C	.037 (0.94)	.039 (0.99)
D	-----	.450 (11.43)
E	.170 (4.32)	-----
F	.130 (3.30)	.160 (4.06)
G	.000 (0.00)	.040 (1.02)

NOTES:

1. Dimensions are in inches.
2. Metric equivalents are given for information only.
3. This interface shall meet the gauge requirements as specified in MIL-DTL-25516.

FIGURE 316-1. Interface, coaxial, pin contact, environment resistant.

MIL-STD-348B
 w/CHANGE 2

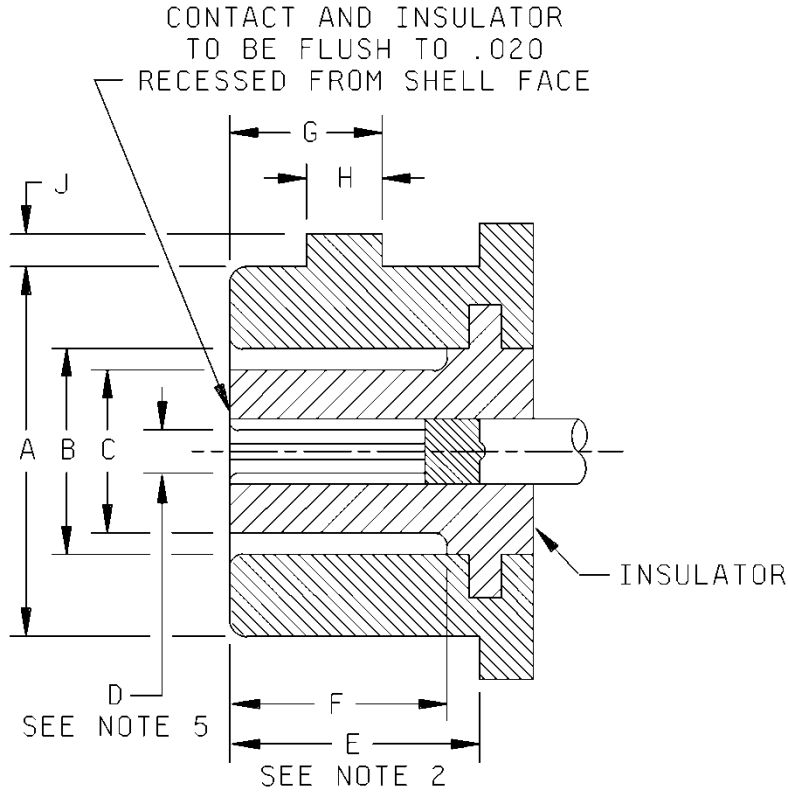

RECEPTACLE WITH SOCKET CONTACT

Dimension Ltr.	Inches (mm)	
	Minimum	Maximum
A DIA.	.286 REF	-----
B	.196	-----
C	-----	.128
D	.041	.043
E	.250	-----
F	.180	-----
G	.151 REF	-----
H lug	.055 REF	-----
J	.027 TYP	

NOTES:

1. Dimensions are in inches.
2. Clearance for mating connector coupling nut.
3. Metric equivalents are given for information only.
4. This interface shall meet the gauge requirements as specified in MIL-DTL-25516.
5. .170 inch (4.32 mm) minimum deep.

FIGURE 316-2. Interface, coaxial, socket contact, environment resistant.

MIL-STD-348B
 w/CHANGE 2

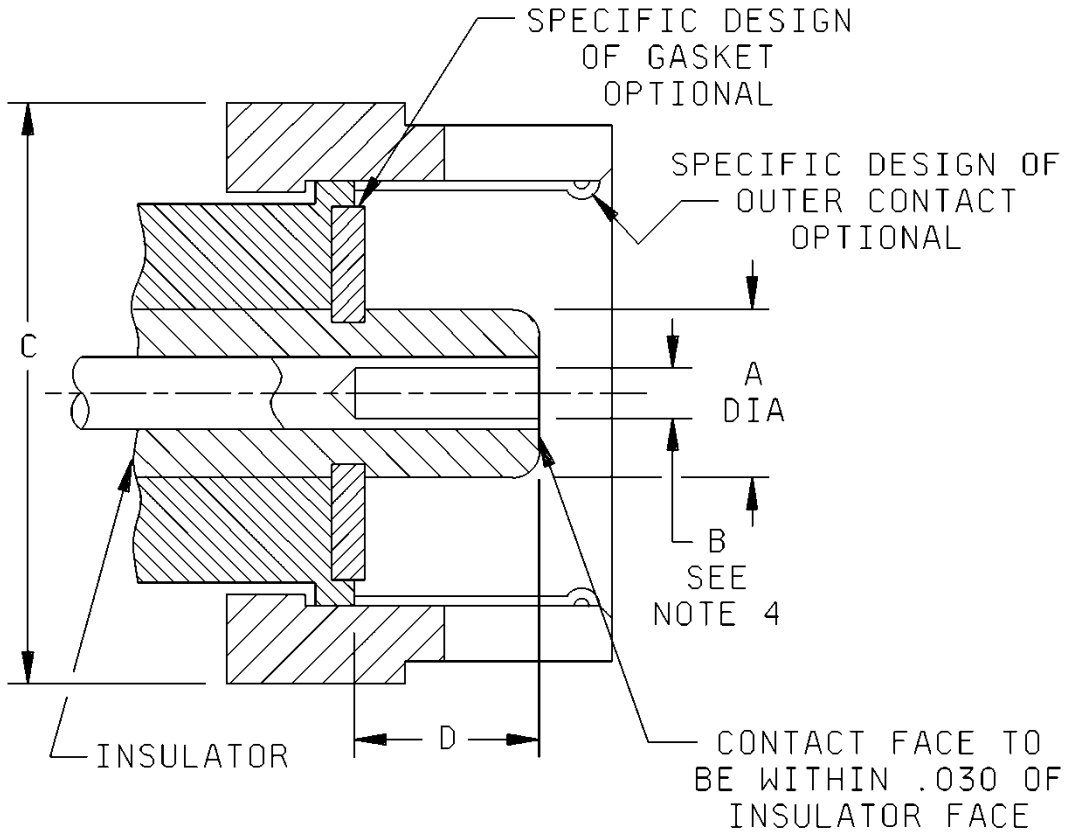

PLUG WITH SOCKET CONTACT

Dimension Ltr.	Inches (mm)	
	Minimum	Maximum
A	-----	.128
B	.041	.043
C	-----	.450
D	.130	.160

NOTES:

1. Dimensions are in inches.
2. Metric equivalents are given for information only.
3. This interface shall meet the gauge requirements as specified in MIL-DTL-25516.
4. .170 inch (4.32 mm) minimum deep.

FIGURE 316-3. Interface, coaxial, socket contact, environment resistant.

MIL-STD-348B
 w/CHANGE 2

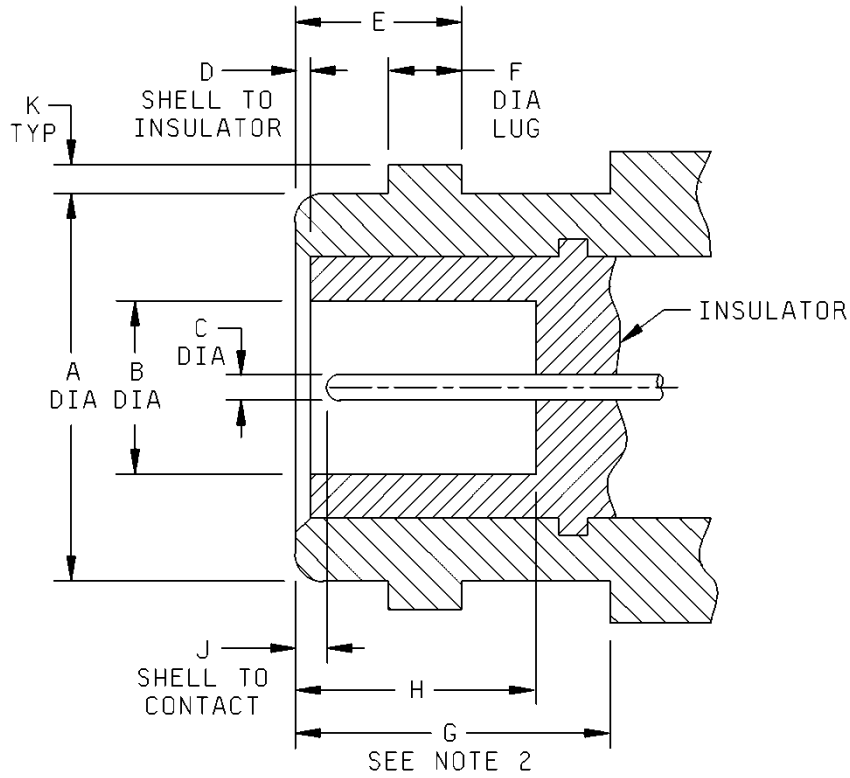

RECEPTACLE WITH PIN CONTACT

Dimension Ltr.	Inches (mm)	
	Minimum	Maximum
A	.286 (7.26) REF	-----
B	.130 (3.30)	-----
C	.037 (0.94)	.039 (0.99)
D	.000 (0.00)	.020 (0.51)
E	.151 (3.84) REF	-----
F	.055 (1.40) REF	-----
G	.250 (6.35)	-----
H	.180 (4.57)	-----
J	.000 (0.00)	.040 (1.02)
K	.027 (0.69) Typical	

NOTES:

1. This interface shall meet the gauge requirements as specified in MIL-DTL-25516.
2. Clearance for mating connector coupling nut.
3. Dimensions are inches.
4. Metric equivalents are given for information only.

FIGURE 316-4. Interface, coaxial, pin contact, environment resistant.

MIL-STD-348B
 w/CHANGE 2

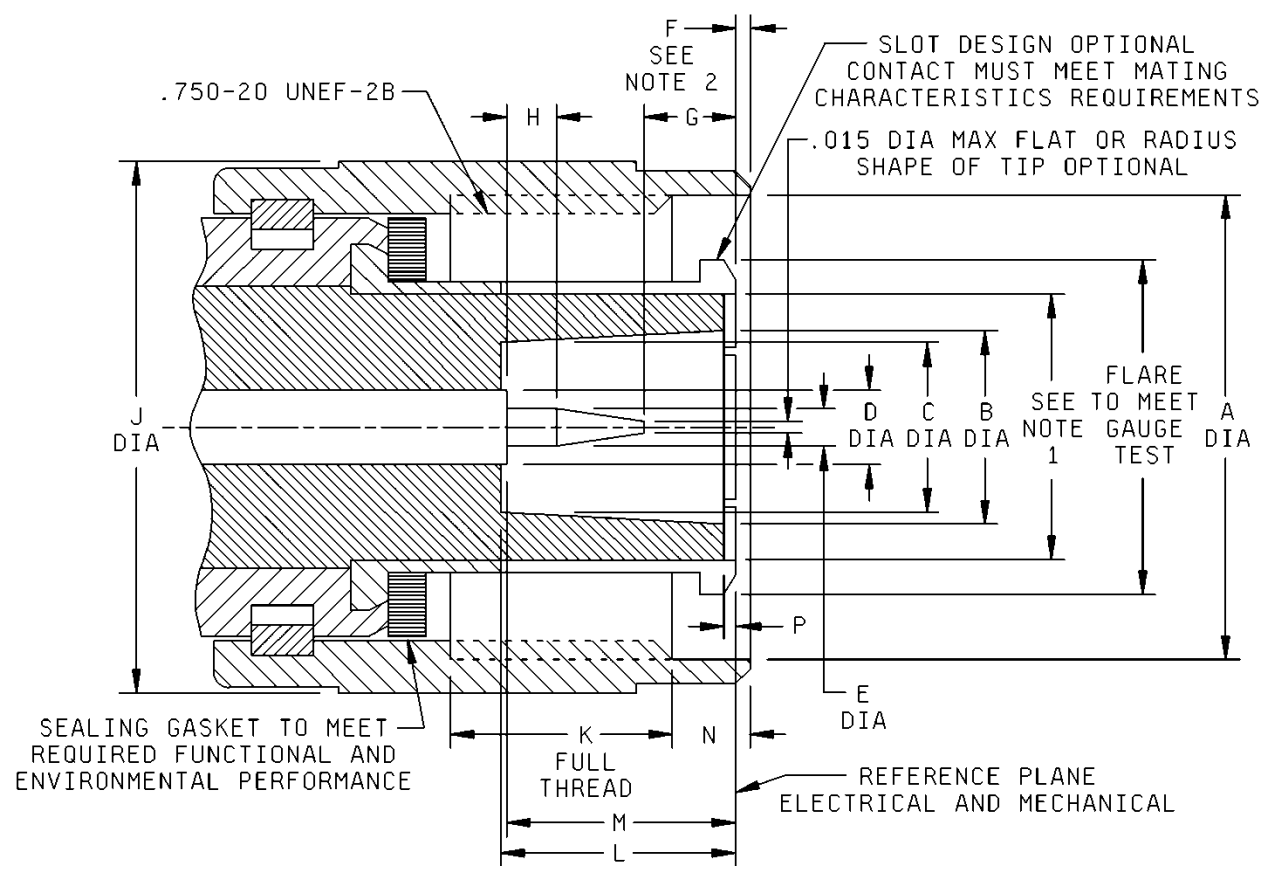

FIGURE 317-1. Interface, series HN, pin contact.

MIL-STD-348B
 w/CHANGE 2

Dimension Ltr.	Inches (mm)	
	Minimum	Maximum
A	.760 (19.30)	-----
B	.289 (7.34)	-----
C	.263 (6.68)	-----
D	-----	.132 (3.35)
E	.062 (1.57)	.066 (1.68)
F	-----	.058 (1.47)
G	.138 (3.51)	-----
H	.120 (3.05)	-----
J	-----	.925 (23.50)
K	.403 (10.24)	-----
L	.368 (9.35)	-----
M	.356 (9.04)	.388 (9.86)
N	.100 (2.54)	-----
P	.005 (0.13)	-----

NOTE:

1. ID of outer contact when inserted into a .548 inch (13.92 mm) maximum diameter ring gauge shall be .432 inch (10.97 mm) minimum.
2. With nut biased in forward position.

FIGURE 317-1. Interface, series HN, pin contact – Continued.

MIL-STD-348B
 w/CHANGE 2

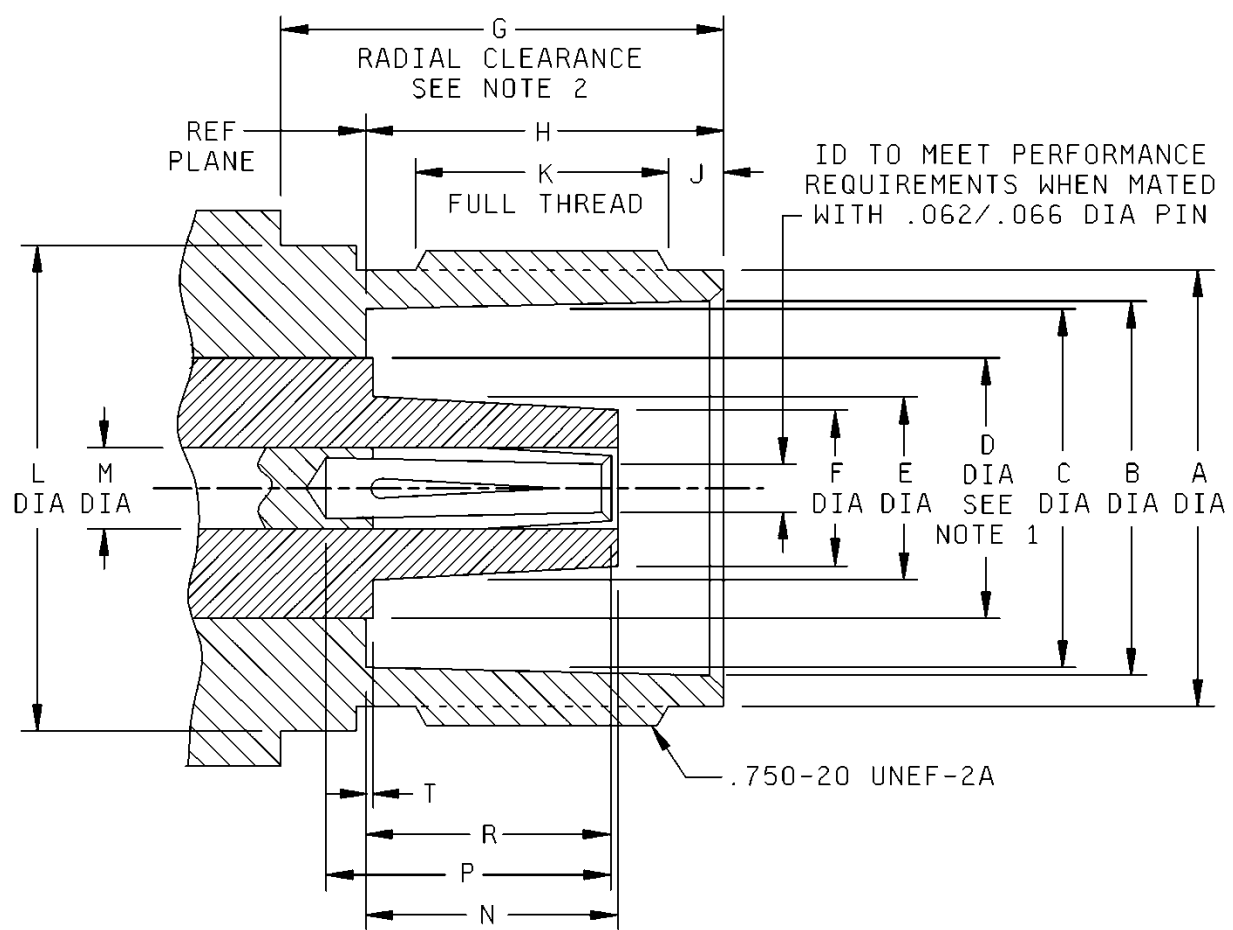

FIGURE 317-2. Interface, series HN, socket contact.

**MIL-STD-348B
 w/CHANGE 2**

Dimension Ltr.	Inches (mm)	
	Minimum	Maximum
A	.662 (16.81)	.683 (17.35)
B	.571 (14.50)	.578 (14.68)
C	.548 (13.92)	.553 (14.05)
D	-----	.430 (10.92)
E	-----	.294 (7.47)
F	-----	.268 (6.81)
G	.590 (14.99)	-----
H	.516 (13.11)	.522 (13.26)
J	.077 (1.96)	.087 (2.21)
K	.359 (9.12)	-----
L	-----	.755 (19.18)
M	-----	.132 (3.35)
N	-----	.368 (9.35)
P	.355 (9.02)	-----
R	.328 (8.33)	.358 (9.09)
T	-----	.005 (0.13)

NOTES:

1. Dielectric protrusion beyond reference plane.
2. Clearance for mating connector coupling nut.
3. Dimensions are in inches.
4. Metric equivalents are given for information only.

FIGURE 317-2. Interface, series HN, socket contact – Continued.

MIL-STD-348B
 w/CHANGE 2

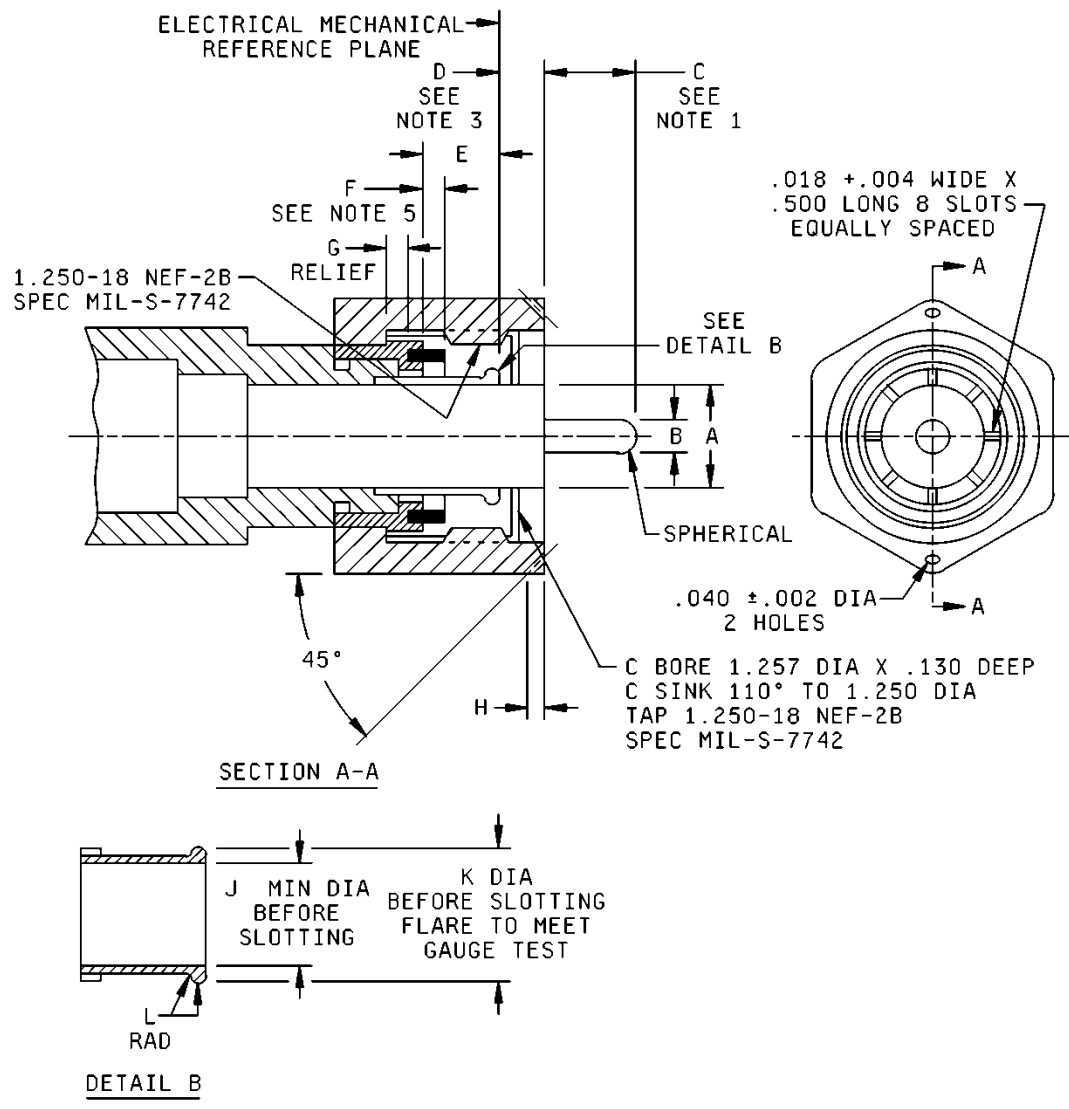

FIGURE 318-1. Interface, series LT, without contact.

MIL-STD-348B
 w/CHANGE 2

Dimension Ltr.	Inches (mm)	
	Minimum	Maximum
A	.618 (15.70)	.620 (15.75)
B	.186 (4.72)	.188 (4.78)
C	.468 (11.89)	.500 (12.70)
D	.250 (6.35)	.260 (6.60)
E	.433 (11.00)	.441 (11.20)
F	.099 (2.51)	.119 (3.02)
G	.094 (2.39) relief	
H	.094 (2.39)	
J	.621 (15.77)	-----
K	.785 (19.94)	.786 (19.96)
L	.046 (1.17)	

NOTES:

1. This dimension is from the tip of the center contact to the end of the dielectric.
2. Dimensions are in inches.
3. This dimension is from the end of the outer contact to the end of the dielectric.
4. Unless otherwise specified, all tolerances shall be ± 0.005 inch.
5. The gasket upon mating with the mating connector shall meet the electrical and environmental performance requirements.

FIGURE 318-1. Interface, series LT, without contact – Continued.

MIL-STD-348B
 w/CHANGE 2

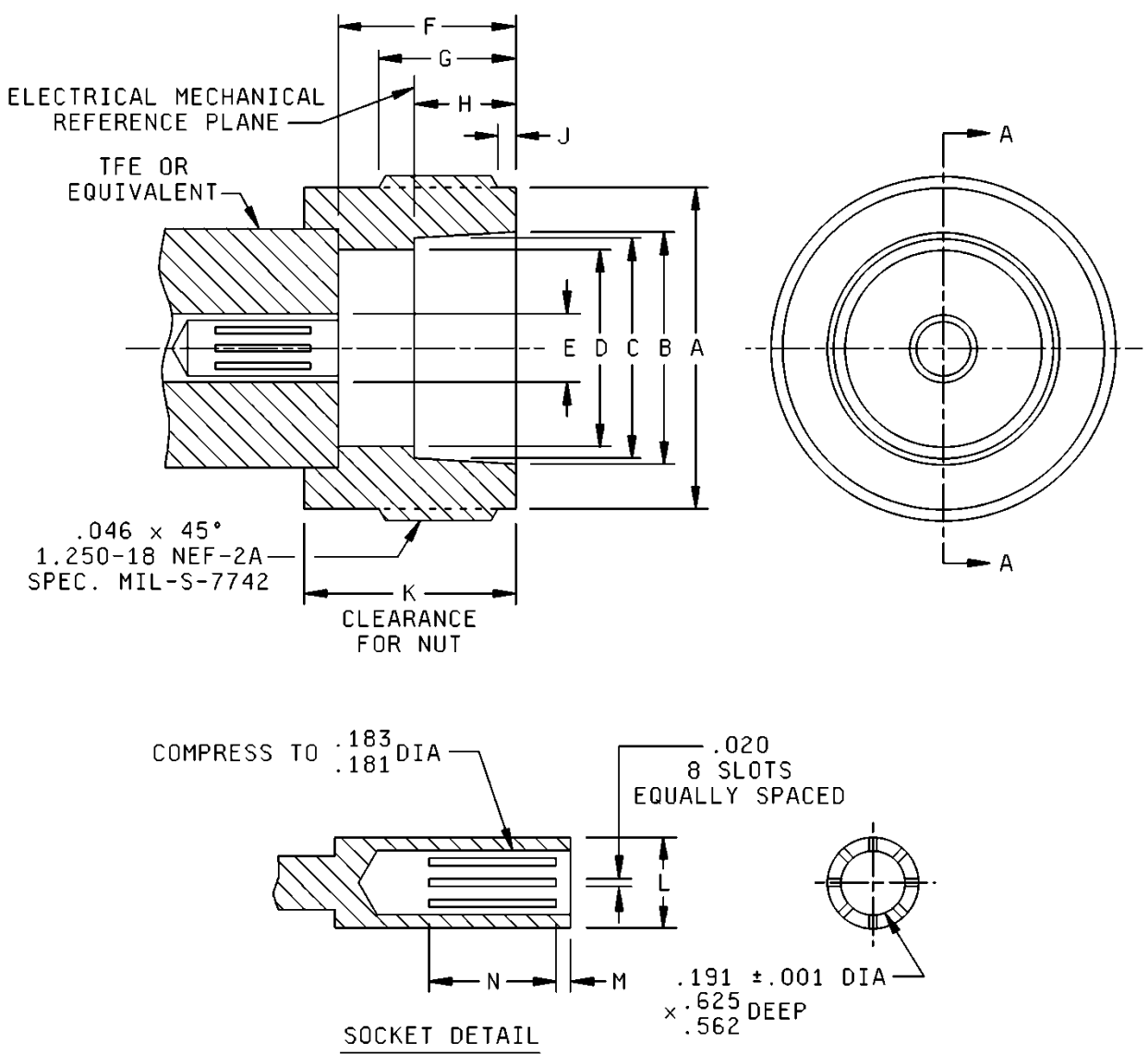

FIGURE 318-2. Interface, series LT, socket contact.

**MIL-STD-348B
w/CHANGE 2**

Dimension Ltr.	Inches (mm)	
	Minimum	Maximum
A	1.150 (29.21)	
B	.798 (20.27)	.806 (20.47)
C	.788 (20.02)	.790 (20.07)
D	.621 (15.77)	.623 (15.82)
E Ref.	.217 (5.51)	.218 (5.54)
F	.618 (15.70)	.624 (15.85)
G	.562 (14.27)	
H	.374 (9.50)	.376 (9.55)
J	.140 (3.56)	
K	.750 (19.05)	-----
L	.217 (5.51)	.218 (5.54)
M	.094 (2.39)	
N	.437 (11.10)	

NOTES:

1. Dimensions are in inches.
2. Unless otherwise specified, all tolerances shall be ± 0.005 inch.

FIGURE 318-2. Interface, series LT, socket contact – Continued.

MIL-STD-348B
 w/CHANGE 2

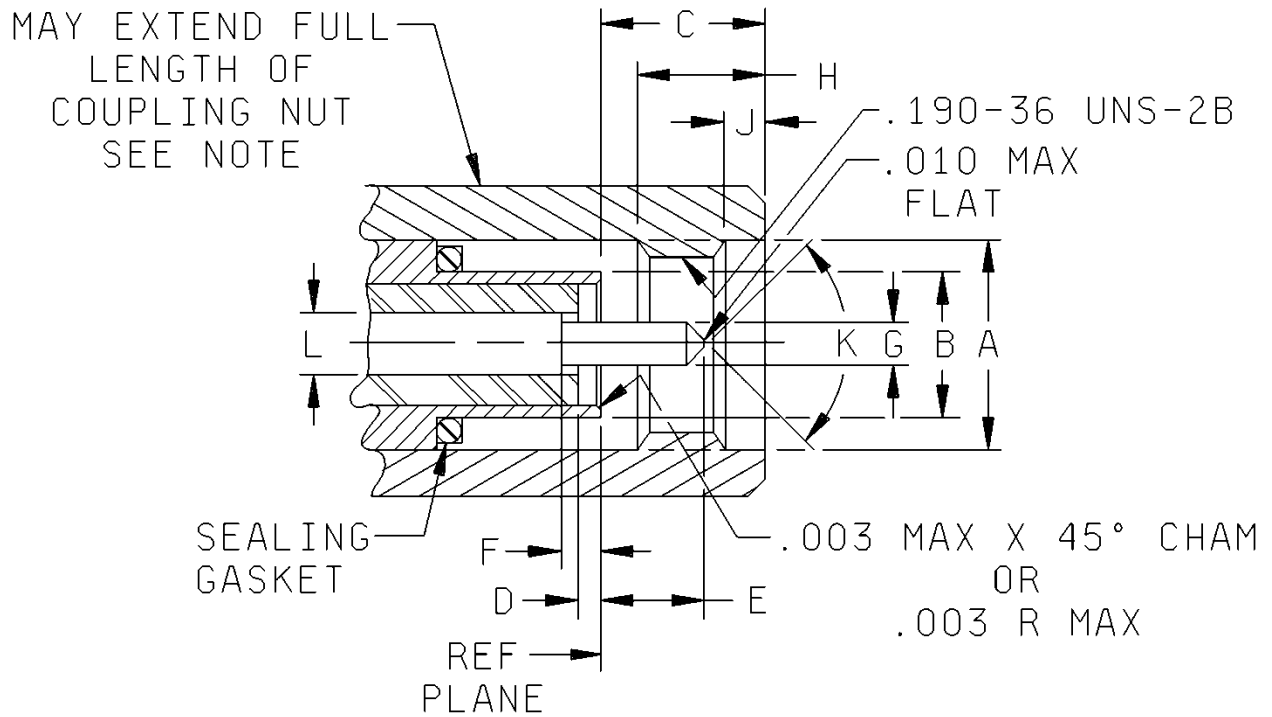

NOTE. .250 reference hex (across flats) may extend full length of coupling nut per FED-STD-H28.

Letter	Inches (mm)	
	Minimum	Maximum
A dia.	.196 (4.98)	.202 (5.13)
B dia.	.124 (3.15)	.1268 (3.22)
C	.100 (2.54)	.133 (3.38)
D	.000 (.00)	.010 (0.25)
E	.050 (1.27)	.065 (1.65)
F	.000 (0.00)	.010 (0.25)
G dia.	.0195 (0.50)	.0208 (0.53)
H	.130 (3.30)	-----
J	.015 (0.38)	.045 (1.14)
K	70°	95°
L dia.	-----	.0348 (0.88)

FIGURE 319-1. Interface, series SSMA, pin contact.

MIL-STD-348B
 w/CHANGE 2

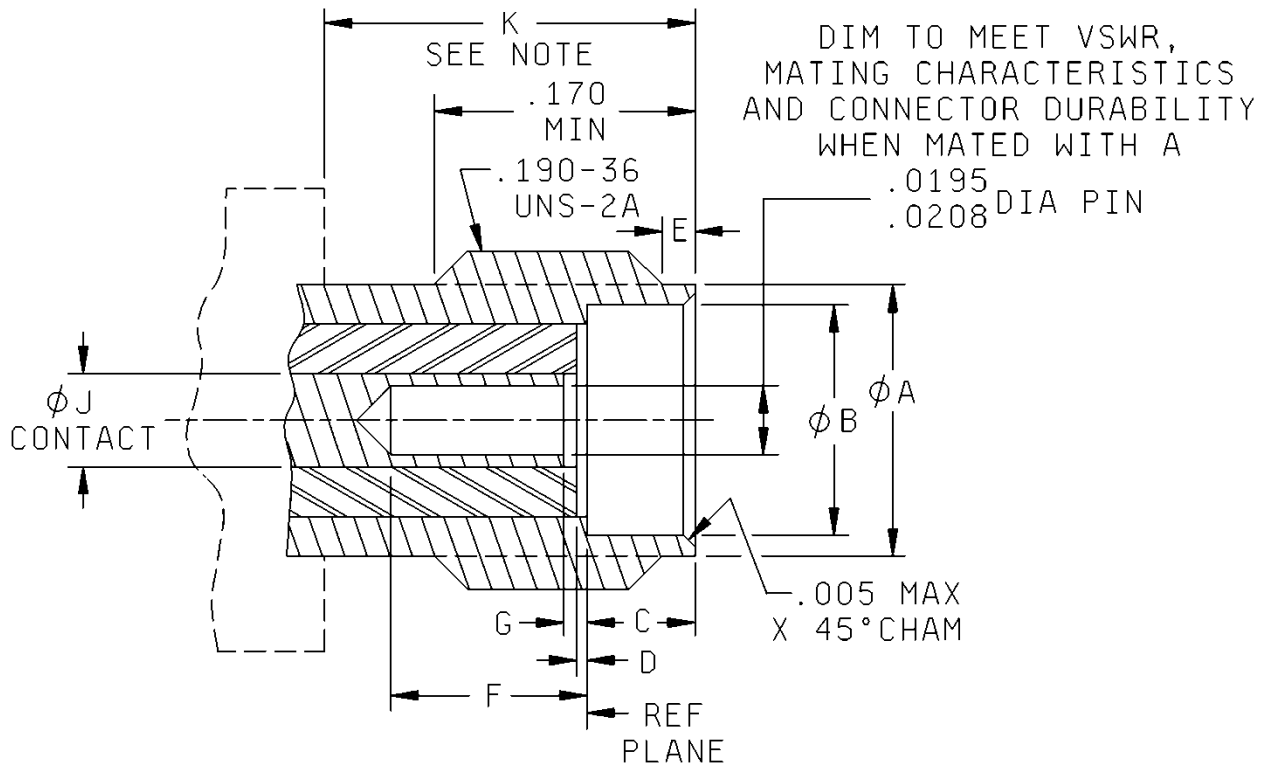

Letter	Inches (mm)	
	Minimum	Maximum
A dia.	.147 (3.73)	.160 (4.06)
B dia.	.127 (3.23)	.130 (3.30)
C	.075 (1.91)	.077 (1.96)
D	.000 (0.00)	.010 (0.25)
E	.020 (0.51)	.040 (1.02)
F	.075 (1.91)	-----
G	.000 (0.00)	.010 (0.25)
J dia.	.0335 (0.85)	.0348 (0.88)
K	.230 (5.84)	-----

NOTE: Clearance for coupling nut.

FIGURE 319-2. Interface, series SSMA, socket contact.

MIL-STD-348B
w/CHANGE 2

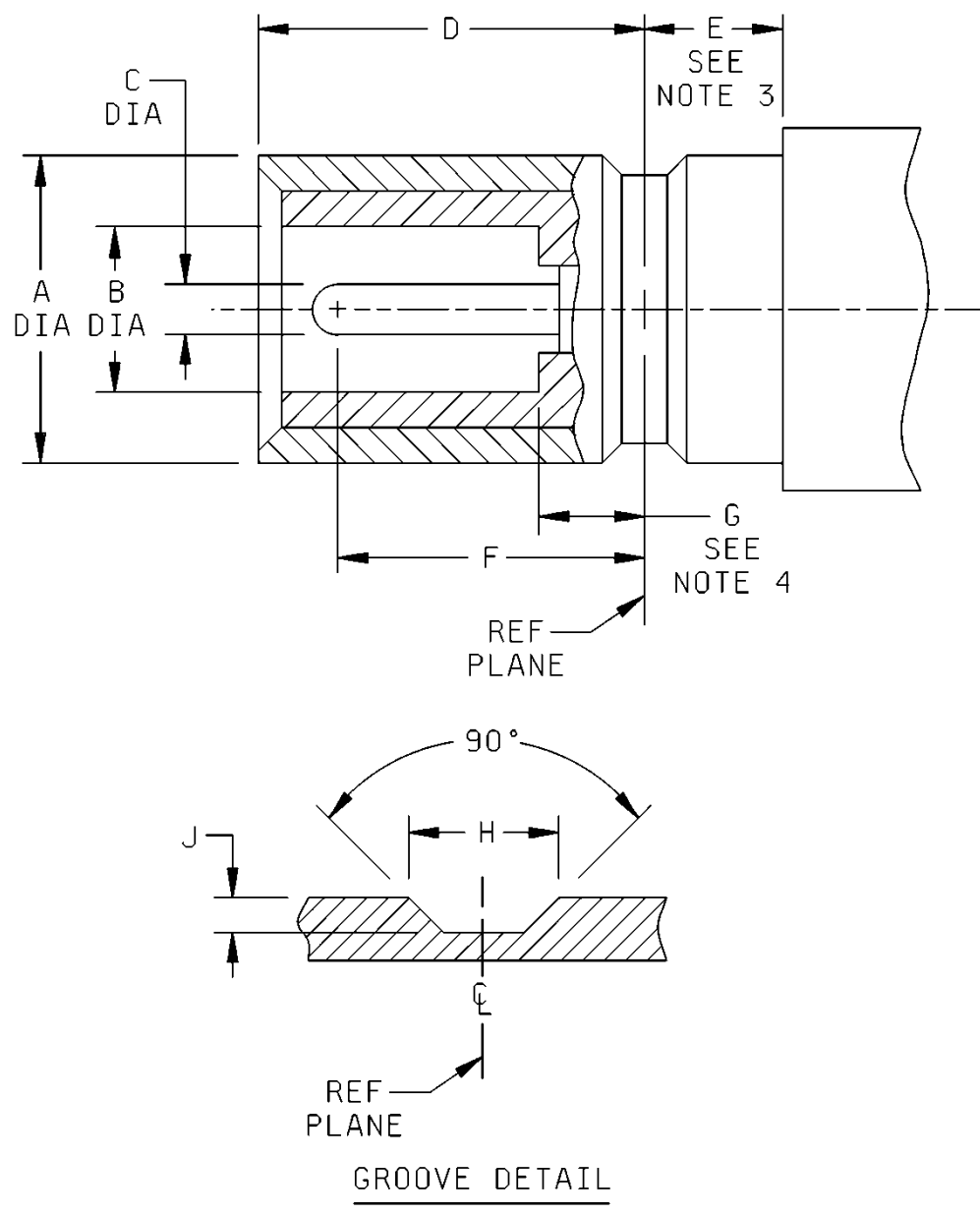

FIGURE 320-1. Interface, series SSMB, pin contact.

**MIL-STD-348B
 w/CHANGE 2**

Letter	Inches (mm)	
	Minimum	Maximum
A	-----	.105 (2.67)
B	.054 (1.37)	-----
C	.014 (0.36)	.015 (0.38)
D	.122 (3.10)	
E	.075 (1.91)	-----
F	.075 (1.91)	-----
G	-----	.033 (0.84)
H	.028 (0.71)	.029 (0.74)
J	.002 (0.56)	.006 (0.15)

NOTES:

1. All undimensioned pictorial representations are for reference purposes only.
2. Unless otherwise specified, all tolerances shall be ± 0.005 inch.
3. Clearance for mating connector coupling nut.
4. This dimension (.033 max.) applies to both the insulator and the contact.

FIGURE 320-1. Interface, series SSMB, pin contact – Continued.

MIL-STD-348B
 w/CHANGE 2

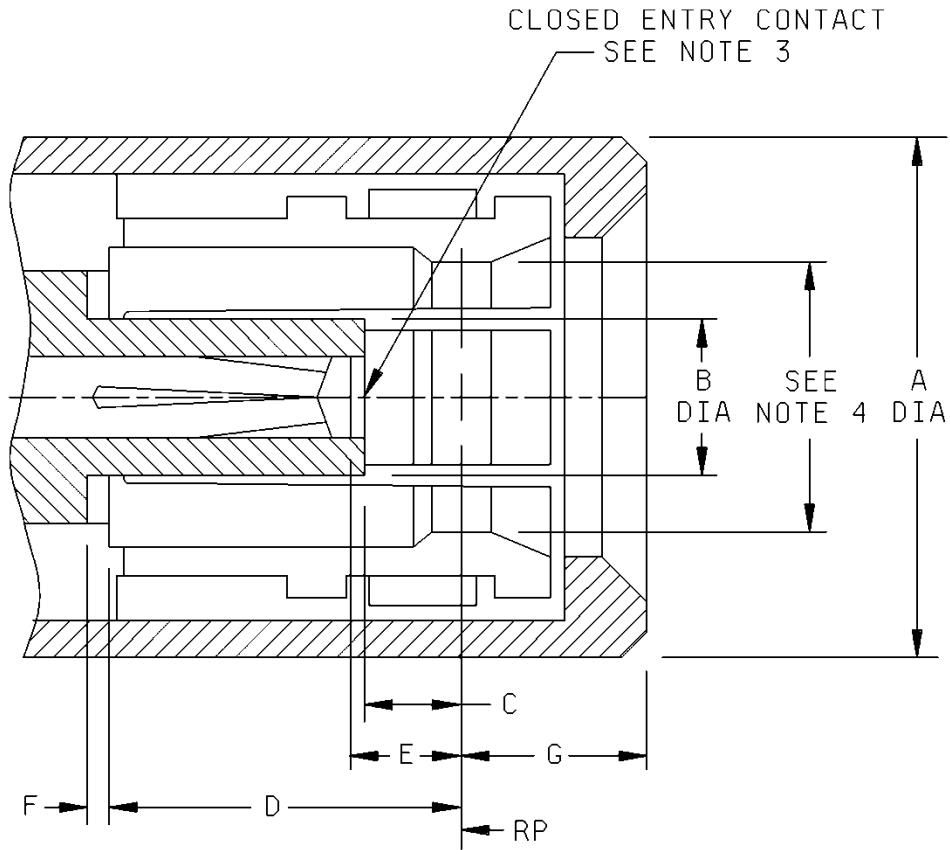

Letter	Inches(mm)	
	Minimum	Maximum
A	-----	.190 (4.83)
B	-----	.053 (1.35)
C	.033 (0.84)	-----
D	.122 (3.10)	-----
E	.033 (0.84)	-----
F	.000 (0.00)	-----
G	-----	.070 (1.78)

NOTES:

1. All undimensioned pictorial representations are for reference purposes only.
2. Unless otherwise specified, all tolerances shall be ± 0.005 .
3. Inside diameter of contact to meet VSWR, mating characteristics and connector durability when mated with a .014/.015 inch diameter pin contact.
4. Must meet the force to engage/disengage requirement when mated with its mating part.

FIGURE 320-2. Interface, series SSMB, socket contact.

MIL-STD-348B
 w/CHANGE 2

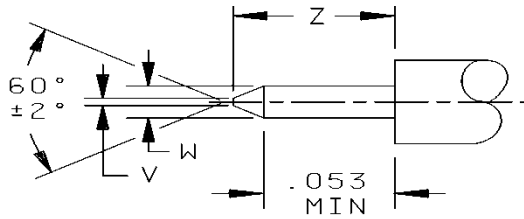
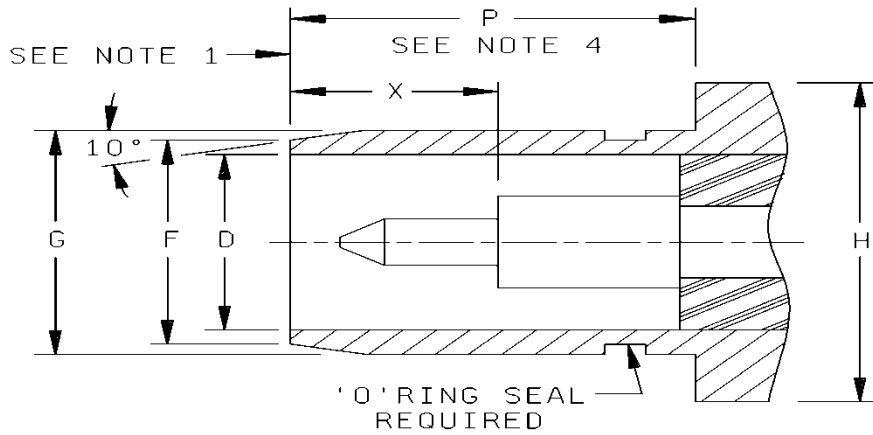

Letter	Inches (mm)	
	Minimum	Maximum
D	.161 (4.09) nominal	
F	.192 (4.88) nominal	
G	.209 (5.31)	.211 (5.36)
H	.300 (7.62) nominal	
P	.198 (5.03)	-----
V	-----	.015 (0.38)
W	.0354 (0.90)	.0370 (0.94)
X	.128 (3.25)	-----
Z	.090 (2.29) nominal	

FIGURE 321-1. Interface, series BMA, pin contact.

MIL-STD-348B
 w/CHANGE 2

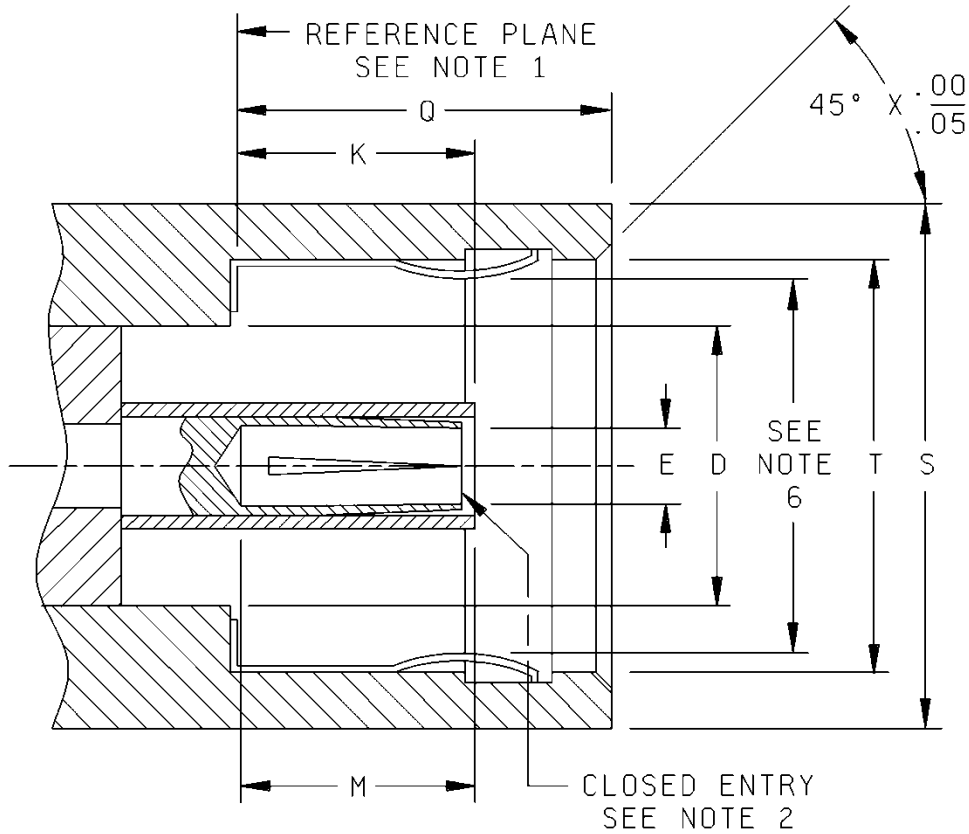

Letter	Inches (mm)		Notes
	Minimum	Maximum	
D	.161 (4.09) nominal		
E	-----	-----	2
K	.120 (3.05)	.127 (3.23)	
M	.115 (2.92)	-----	
Q	-----	.198 (5.03)	3
S	.290 (7.37)	-----	
T	.225 (5.72)	-----	

NOTES:

1. Reference plane.
2. Bore diameter closed to meet electrical and mechanical requirements when mated with a .0355/.0370 inch pin. (.902/.940mm)
3. With spring finger bottomed.
4. Clearance for mating connector coupling nut.
5. Patent notice: See 6.2 for U.S. patent number 4,426,127.
6. To meet mechanical and electrical requirements of MIL-PRF-31031.

FIGURE 321-2. Interface dimension, series BMA, socket contact.

MIL-STD-348B
 w/CHANGE 2

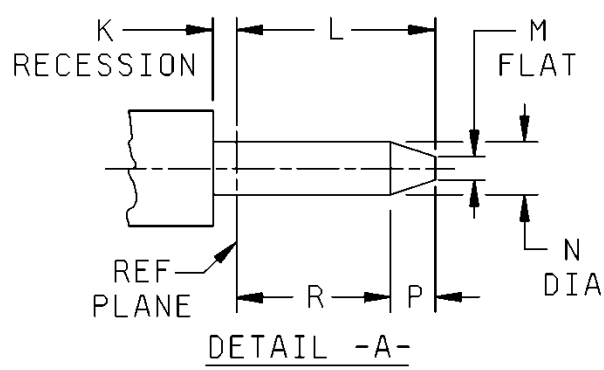
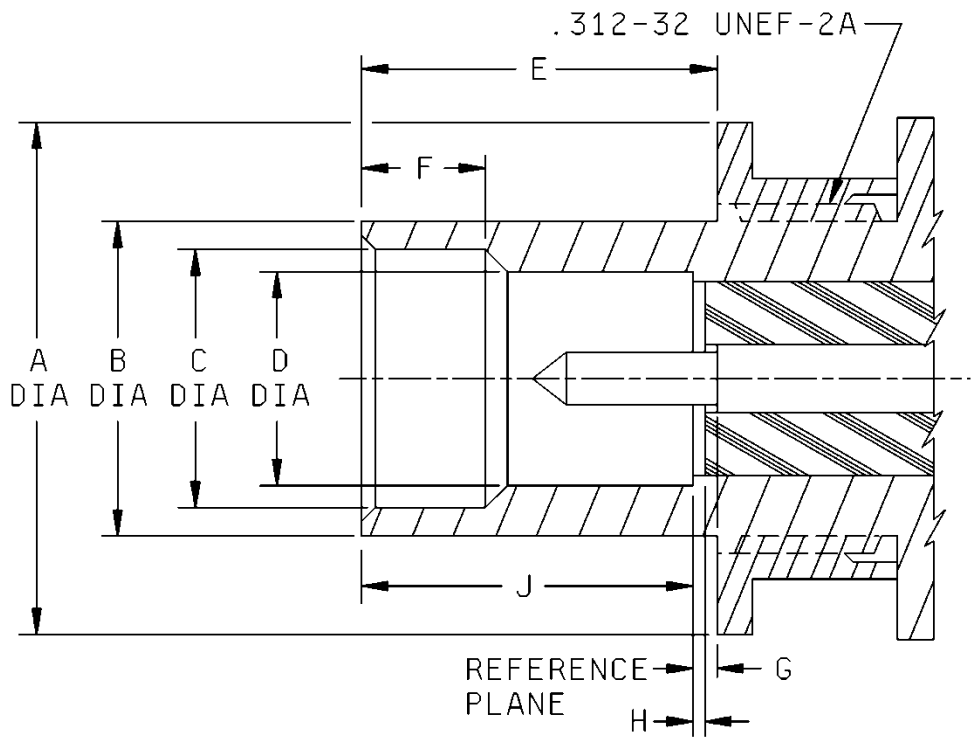

FIGURE 322-1. Interface, series BMB, pin contact.

MIL-STD-348B
 w/CHANGE 2

Letter	Inches (mm)	
	Minimum	Maximum
A	-----	.468 (11.89)
B	-----	.272 (6.91)
C	.223 (5.66)	-----
D	.1805 (4.58)	.1835 (4.66)
E	.272 (6.91)	-----
F	.090 (2.29)	.100 (2.54)
G	.000 (.00)	.010 (0.25)
H	.000 (.00)	.010 (0.25)
J	.240 (6.10)	.250 (6.35)
K	.000 (0.00)	.010 (0.25)
L	-----	.100 (2.54)
M	-----	.015 (0.38)
N	.0355 (0.90)	.0370 (0.94)
P	.015 (0.38)	-----
R	.050 (1.27)	-----

NOTES:

1. Patent notice: See 6.2 for U.S. patent number 4,358,174.
2. Unless otherwise specified, tolerances shall be ± 0.005 inch.

FIGURE 322-1. Interface, series BMB, pin contact – Continued.

MIL-STD-348B
 w/CHANGE 2

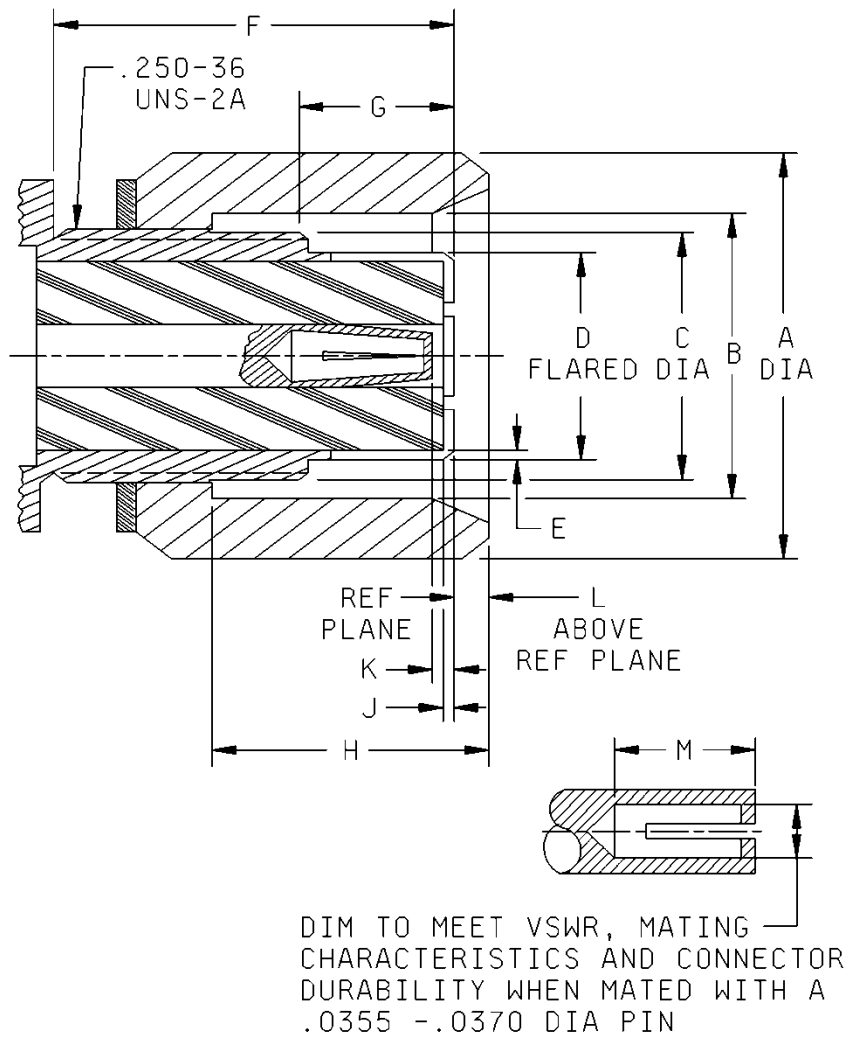

FIGURE 322-2. Interface, series BMB, socket contact.

MIL-STD-348B
 w/CHANGE 2

Letter	Inches (mm)	
	Minimum	Maximum
A	-----	.468 (11.89)
B	.275 (6.99)	-----
C	-----	.222 (5.64)
D	.184 (4.67)	.187 (4.75)
E	.005 (.13) nominal	
F	.438 (11.13)	.442 (11.23)
G	.159 (4.04)	.169 (4.29)
H	.278 (7.06)	-----
J	.000 (0.00)	.010 (0.25)
K	.000 (0.00)	.010 (0.25)
L	.000 (0.00)	.012 (0.30)
M	.115 (2.92)	

NOTES:

1. Patent notice: See 6.2 for U.S. patent number 4,358,174.
2. Unless otherwise specified, all tolerances shall be ± 0.005 inch.

FIGURE 322-2. Interface, series BMB, socket contact – Continued.

MIL-STD-348B
 w/CHANGE 2

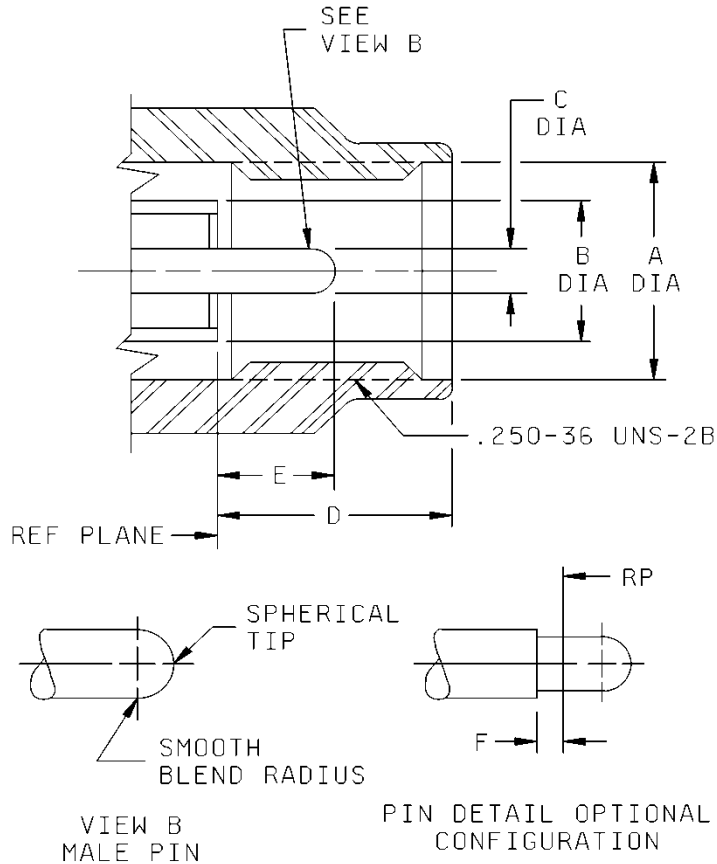

Letter	Inches (mm)	
	Minimum	Maximum
A	.255 (6.48)	-----
B	.178 (4.52)	.180 (4.57)
C	.0355 (0.90)	.0370 (0.94)
D	-----	.135 (3.43)
E	.055 (1.40)	.065 (1.65)
F	.000 (0.00)	.005 (0.13)

NOTES:

1. Dimensions are in inches.
2. Metric equivalents are given for information only.
3. The location of the contact support bead shall not be extended beyond the reference plane.
4. All undimensioned areas including counterbore are to be in accordance with series SMA pin contact interface as specified in this standard.
5. Sealing gasket optional but not required.

FIGURE 323-1. Interface, series SMK, pin contact.

MIL-STD-348B
 w/CHANGE 2

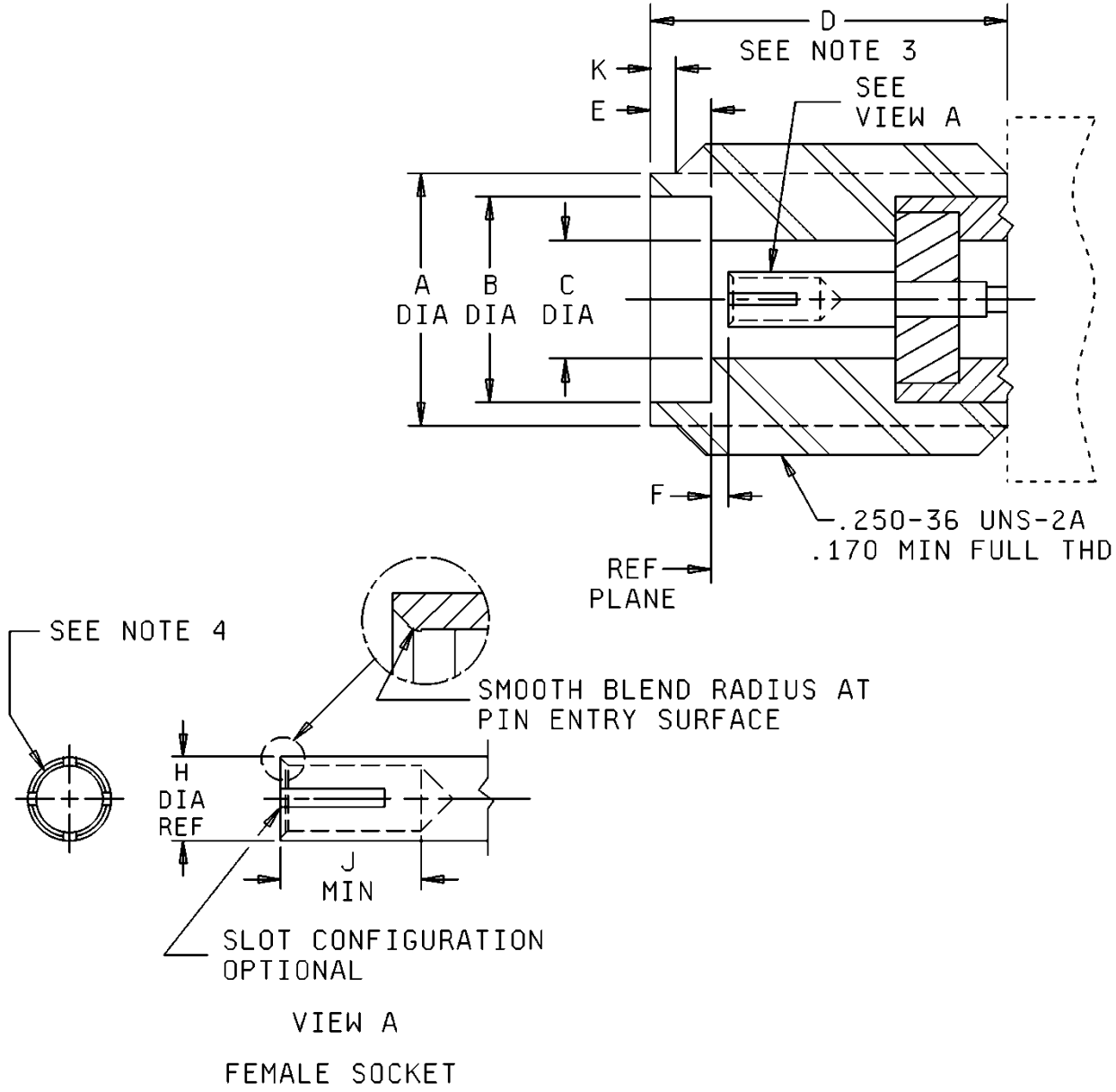

FIGURE 323-2. Interface, series SMK, socket contact.

MIL-STD-348B
 w/CHANGE 2

Letter	Inches (mm)	
	Minimum	Maximum
A	.206 (5.23)	.216 (5.44)
B	.181 (4.60)	.183 (4.65)
C	.114 (2.90)	.116 (2.95)
D	.218 (5.54)	-----
E	.074 (1.88)	.078 (1.98)
F	.000 (.00)	.005 (.13)
G	See note 4	See note 4
H	.050 (1.27) Ref.	
J	.105 (2.67)	-----
K	.015 (0.38)	.045 (1.14)

NOTES:

1. Dimensions are in inches.
2. Metric equivalents are given for information purposes only.
3. Clearance for mating connector coupling nut.
4. Dimensions to meet VSWR, mating characteristics, and connector durability when mated with a .0355 (0.90 mm)/.0370 (0.94 mm) diameter pin.

FIGURE 323-2. Interface, series SMK, socket contact – Continued.

MIL-STD-348B
 w/CHANGE 2

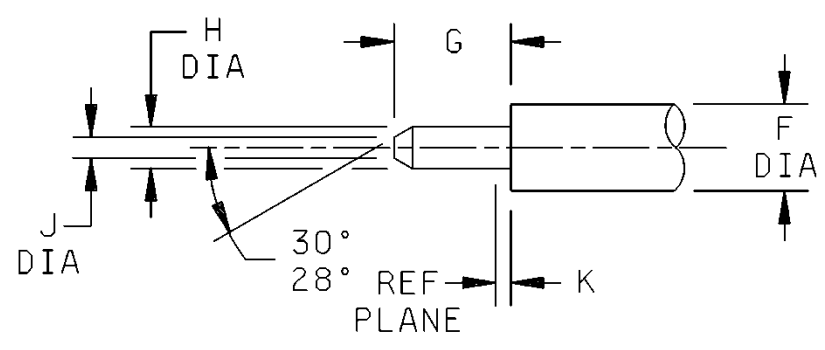
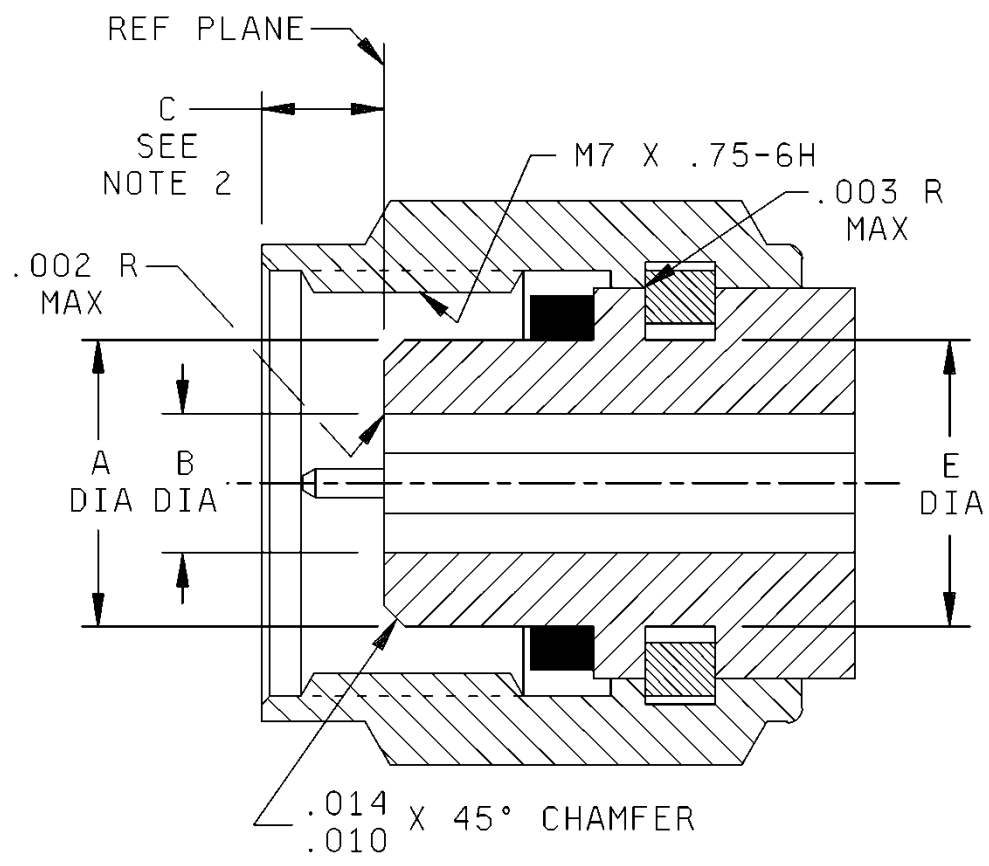

FIGURE 324-1. Interface dimensions (2.4 mm) pin contact.

**MIL-STD-348B
 w/CHANGE 2**

Letter	Millimeters (Inches)	
	Minimum	Maximum
A	4.725 (.186)	4.75 (.187)
B	2.393 (.094)	2.408 (.095)
C	1.85 (.073)	2.45 (.096)
E	4.75 (.187)	4.85 (.191)
F	1.035 (.0407)	1.05 (.0413)
G	1.34 (.053)	1.45 (.057)
H	0.498 (.0196)	0.523 (.0206)
J	-----	0.25 (.010)
K	0.00 (.000)	0.08 (.003)

NOTES.:

1. Thread length is from the end of the coupling nut, 4.37 mm (.172 inch) minimum, 0.63 mm (.025 inch) ± 0.25 mm (.010 inch).
2. With coupling nut biased in the forward direction.
3. Dimensions are in millimeters.
4. Inch-pound equivalents are given for information only.
5. Counter bore 7 mm (.276 inch) minimum.

FIGURE 324-1. Interface dimensions (2.4 mm) pin contact – Continued.

MIL-STD-348B
 w/CHANGE 2

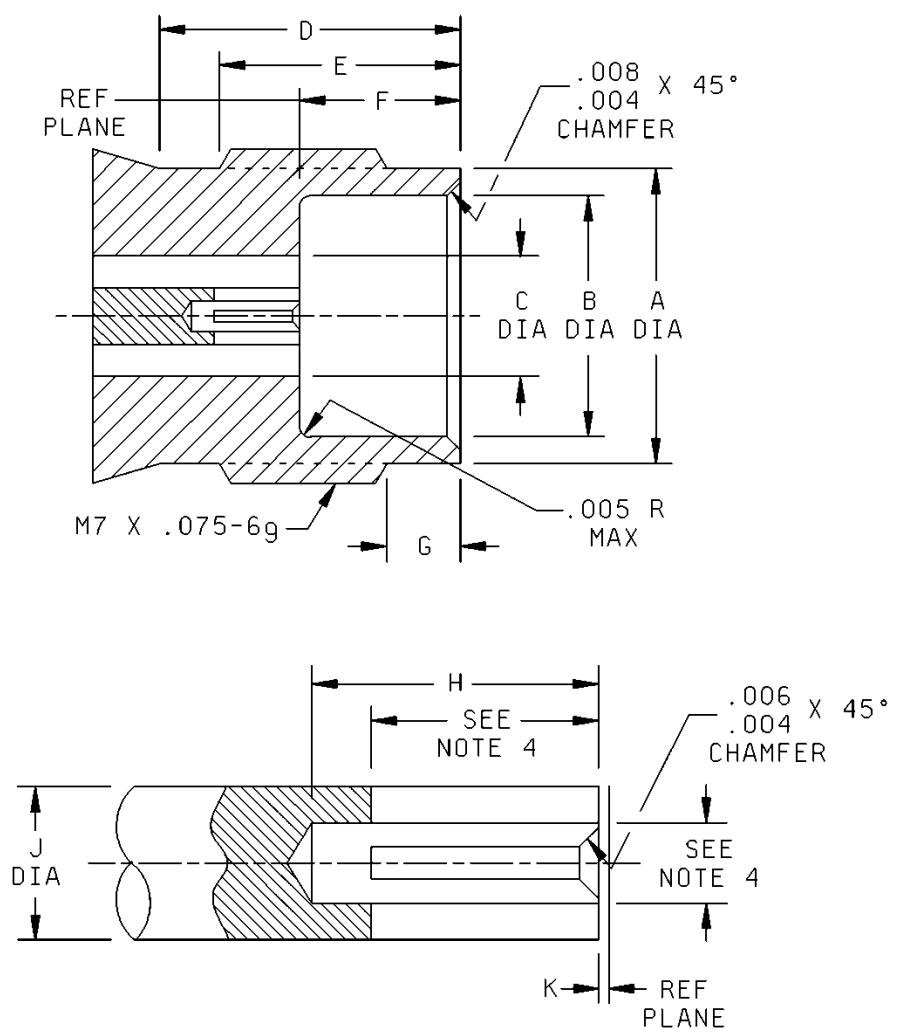

FIGURE 324-2. Interface dimensions (2.4 mm) socket contact.

MIL-STD-348B
 w/CHANGE 2

Letter	Millimeters (Inches)	
	Minimum	Maximum
A	5.79 (.228)	5.89 (.232)
B	4.77 (.1878)	4.80 (.189)
C	2.393 (.094)	2.408 (.095)
D	6.00 (.236)	-----
E	4.80 (.189)	5.06 (.199)
F	3.00 (.118)	3.10 (.122)
G	1.37 (.054)	1.63 (.064)
H	2.65 (.104)	-----
J	1.035 (.04075)	1.05 (.04134)
K	0.00 (.000)	0.076 (.003)

NOTES:

1. Dimensions are in millimeters.
2. Inch-pound equivalents are given for information only.
3. Shall meet the electrical and mechanical performance when mated with a 2.4 mm pin as specified in this standard.

FIGURE 324-2. Interface dimensions (2.4 mm) socket contact – Continued.

MIL-STD-348B
 w/CHANGE 2

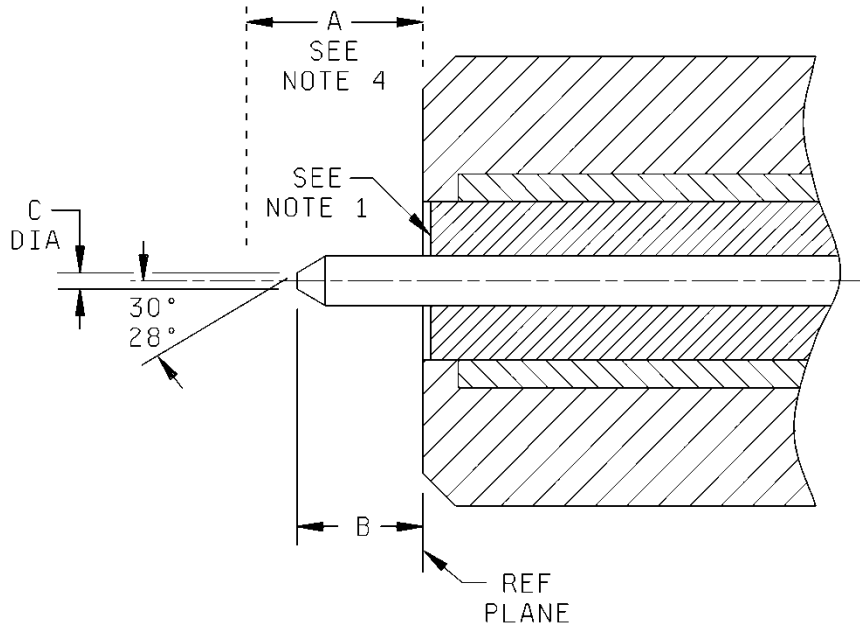

THE CABLE CENTER CONDUCTOR IS USED AS THE CENTER CONTACT PIN AND SHALL BE BETWEEN .0196/.0206 DIA.

Letter	Millimeters (Inches)	
	Minimum	Maximum
A	1.85 (.073)	2.44 (.096)
B	1.27 (.050)	1.45 (.057)
C	-----	0.25 (.010)

NOTES.

1. Insulator to be flush to .0762mm (.003inch) below reference plane.
2. All unspecified dimensions to meet 2.4 mm pin contact.
3. See the manufacturers assembly instructions for cable preparation.
4. With coupling nut biased in the forward direction.

FIGURE 324-3. 2.4 mm Connector Interface without contact.

MIL-STD-348B
w/CHANGE 2

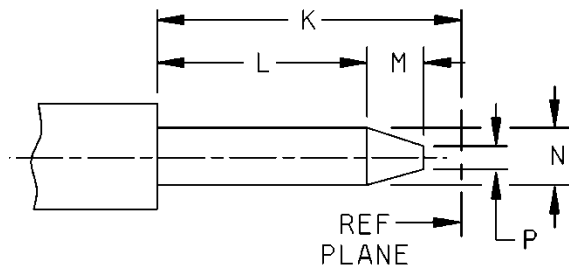
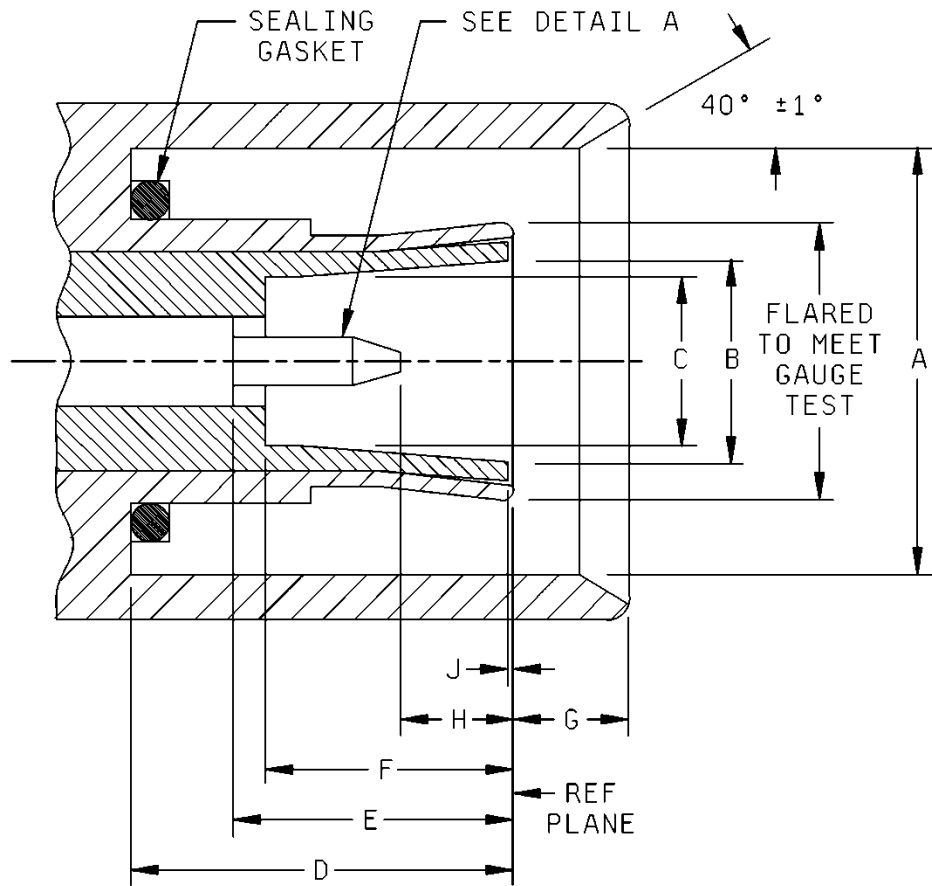

DETAIL A

FIGURE 325-1. Interface, series BMZ, pin contact.

MIL-STD-348B
 w/CHANGE 2

Letter	Inches (mm)	
	Minimum	Maximum
A	.184 (4.67)	-----
B	.087 (2.21)	-----
C	.062 (1.57)	-----
D	.197 (5.00)	.203 (5.16)
E	.130 (3.30)	-----
F	.130 (3.30)	-----
G	.055 (1.40)	.065 (1.65)
H	.030 (0.76)	-----
J	.000 (0.00)	.010 (0.25)
K	.130 (3.30)	-----
L	.060 (1.52)	-----
M	.015 (0.38)	-----
N	.0195 (0.50)	.0210 (0.53)
P	-----	.011 (0.28)

NOTES:

1. Dimensions are in inches.
2. Metric equivalents are given for information purposes only.

FIGURE 325-1. Interface, series BMZ, pin contact – Continued.

MIL-STD-348B
w/CHANGE 2

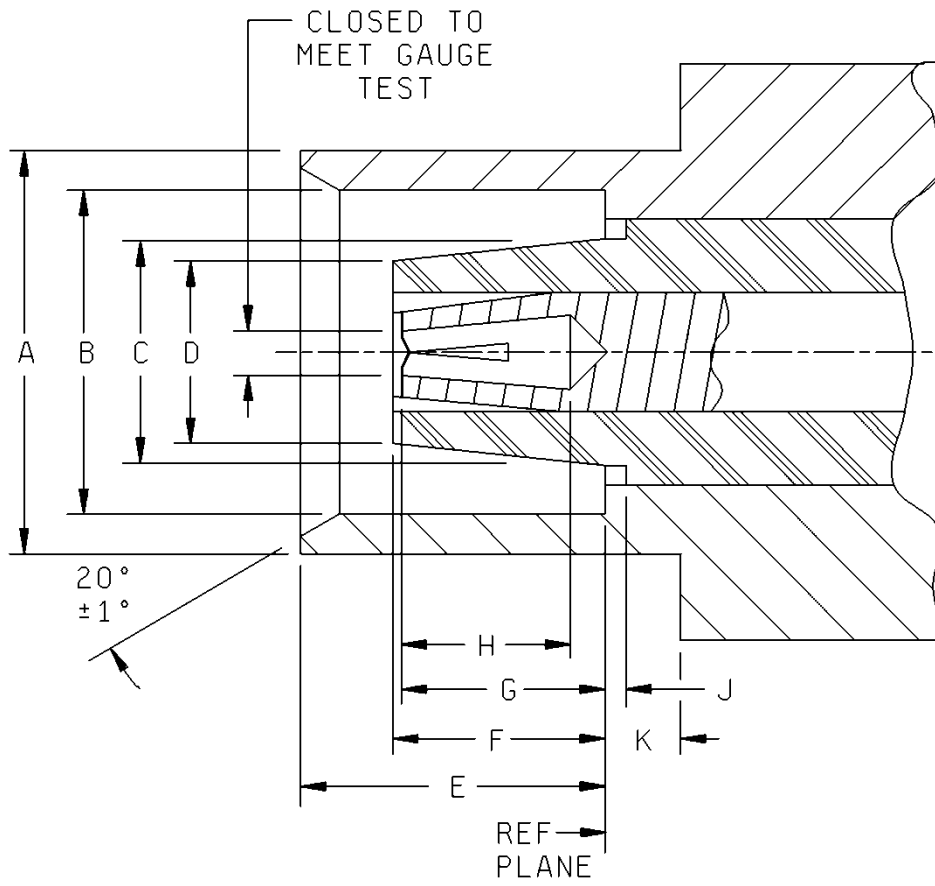

FIGURE 325-2. Interface, series BMZ, socket contact.

MIL-STD-348B
 w/CHANGE 2

Letter	Inches (mm)	
	Minimum	Maximum
A	-----	.182 (4.62)
B	-----	.131 (3.33)
C	-----	.087 (2.21)
D	-----	.062 (1.57)
E	.182 (4.62)	.188 (4.78)
F	-----	.130 (3.30)
G	-----	.130 (3.30)
H	.095 (2.41)	-----
J	.000 (0.00)	.010 (0.25)
K	.070 (1.78)	-----

NOTES:

1. Dimensions are in inches.
2. Metric equivalents are given for information purposes only.

FIGURE 325-2. Interface, series BMZ, socket contact – Continued.

MIL-STD-348B
 w/CHANGE 2

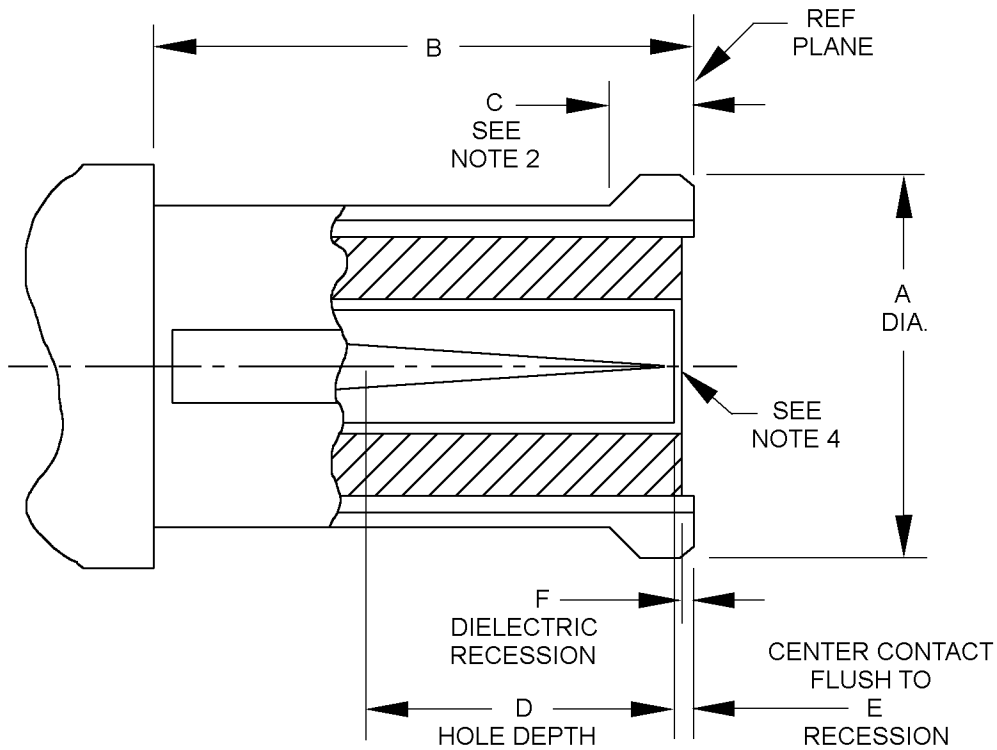

Letter	Inches (mm)	
	Minimum	Maximum
A	-----	.135 (3.43)
B	.112 (2.84)	-----
C	.018 (0.46)	.025 (0.64)
D	.070 (1.78)	-----
E	.000	.008 (0.20)
F	.000 (0.00)	-----

NOTES:

1. Dimensions are in inches. Metric equivalents are given for information purposes only.
2. Form and dimension of outer conductor to meet electrical and mechanical requirements.
3. Interface shall meet the force to engage and disengage requirements in accordance with DSCC drawing 94007.
4. Dimension to meet force to engage and disengage in accordance with specification or drawing.

FIGURE 326-1. Interface, series SMP, socket contact (uncabled connector).

MIL-STD-348B
 w/CHANGE 2

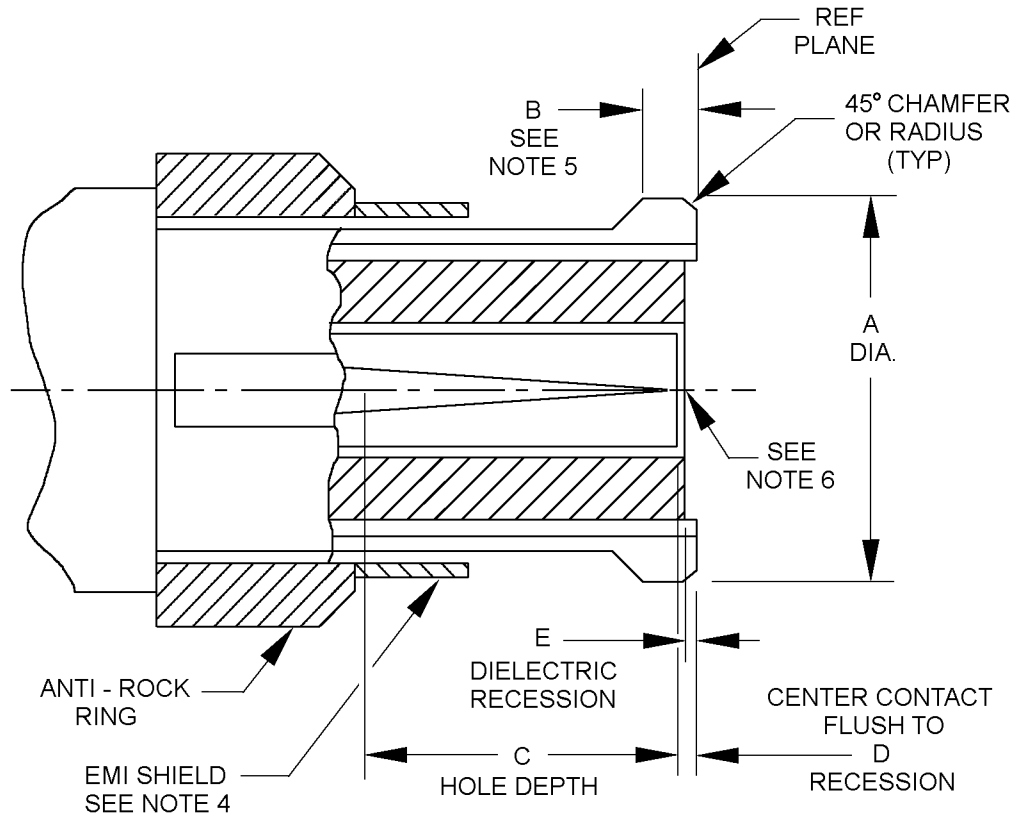

Letter	Inches (mm)	
	Minimum	Maximum
A	-----	.135 (3.43)
B	-----	.0235
C	.070 (1.78)	-----
D	.000	.008 (0.20)
E	.000 (0.00)	-----

Notes:

1. Dimensions are in inches.
2. Metric equivalents are given for information purposes only.
3. Interface shall meet the force to engage and disengage requirements in accordance with DSCC drawing 94008.
4. EMI shield configuration optional. Shall not prevent proper engagement with any required detent. To meet mechanical and electrical requirements of DSCC drawing 94008.
5. Form and dimension of outer conductor to meet electrical and mechanical requirements.
6. Dimension to meet force to engage and disengage in accordance with specification or drawing.

FIGURE 326-1a. Interface, series SMP, socket contact (cabled connector).

MIL-STD-348B
 w/CHANGE 2

Letter	Inches (mm)	
	Minimum	Maximum
A	.139 (3.53)	.145 (3.68)
B	.124 (3.15)	.126 (3.20)
C	.115 (2.92)	.117 (2.97)
D	.108 (2.74)	.112 (2.84)
E	-----	-----
F	.0205 (0.521)	.0235 (0.597)
G	.073 (1.85)	.077 (1.96)
H	.003 (0.08)	.008 (0.20)
J	.045 (1.14)	.055 (1.40)
K	.014 (0.36)	.016 (0.41)

NOTES:

1. Dimensions are in inches.
2. Metric equivalents are given for information purposes only.
3. Pin may not be supplied with shroud, refer to the applicable specification.

FIGURE 326-2. Interface, series SMP, pin contact, full detent – Continued.

MIL-STD-348B
w/CHANGE 2

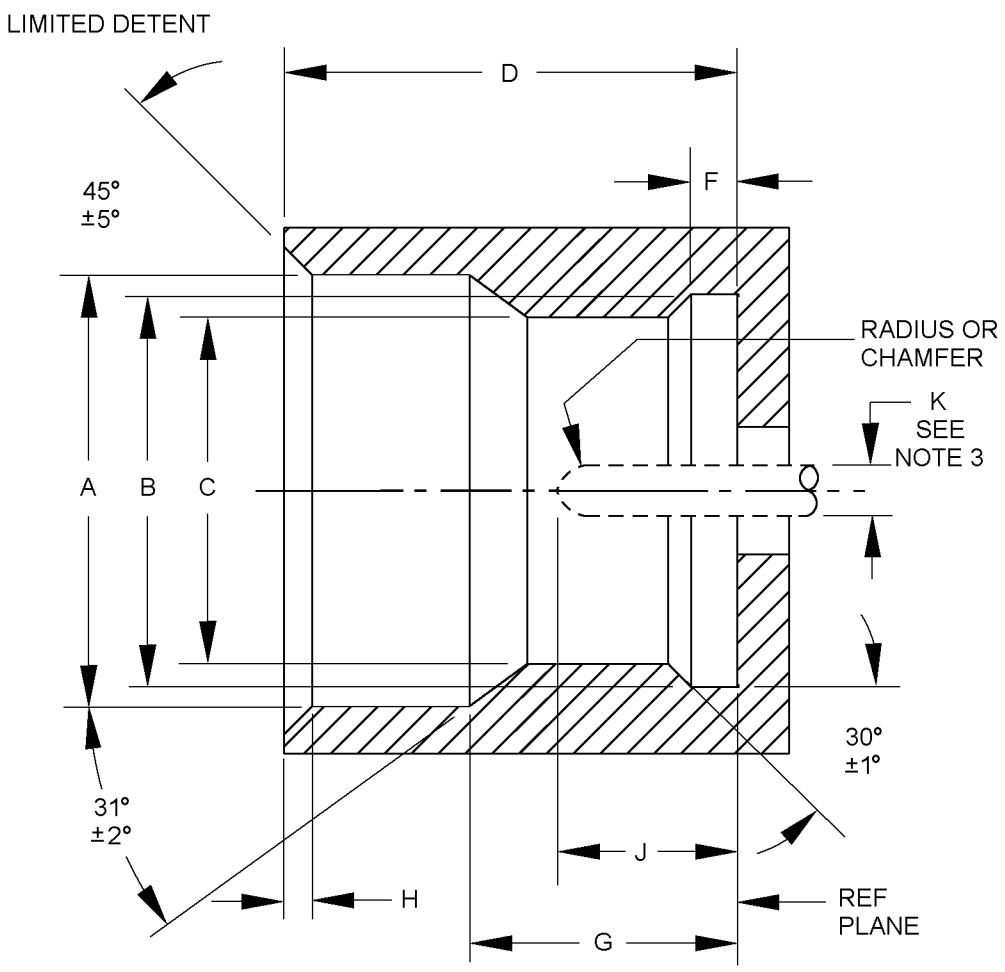

FIGURE 326-3. Interface, series SMP, pin contact, limited detent.

MIL-STD-348B
 w/CHANGE 2

Letter	Inches (mm)	
	Minimum	Maximum
A	.139 (3.53)	.145 (3.68)
B	.124 (3.15)	.126 (3.20)
C	.119 (3.02)	.121 (3.07)
D	.108 (2.74)	.112 (2.84)
E	-----	-----
F	.0205 (0.521)	.0235 (0.597)
G	.073 (1.85)	.077 (1.96)
H	.003 (0.08)	.008 (0.20)
J	.045 (1.14)	.055 (1.40)
K	.014 (0.36)	.016 (0.41)

NOTES:

1. Dimensions are in inches.
2. Metric equivalents are given for information purposes only.
3. Pin may not be shipped with shroud, refer to applicable specification.

FIGURE 326-3. Interface, series SMP, pin contact, limited detent – Continued.

MIL-STD-348B
w/CHANGE 2

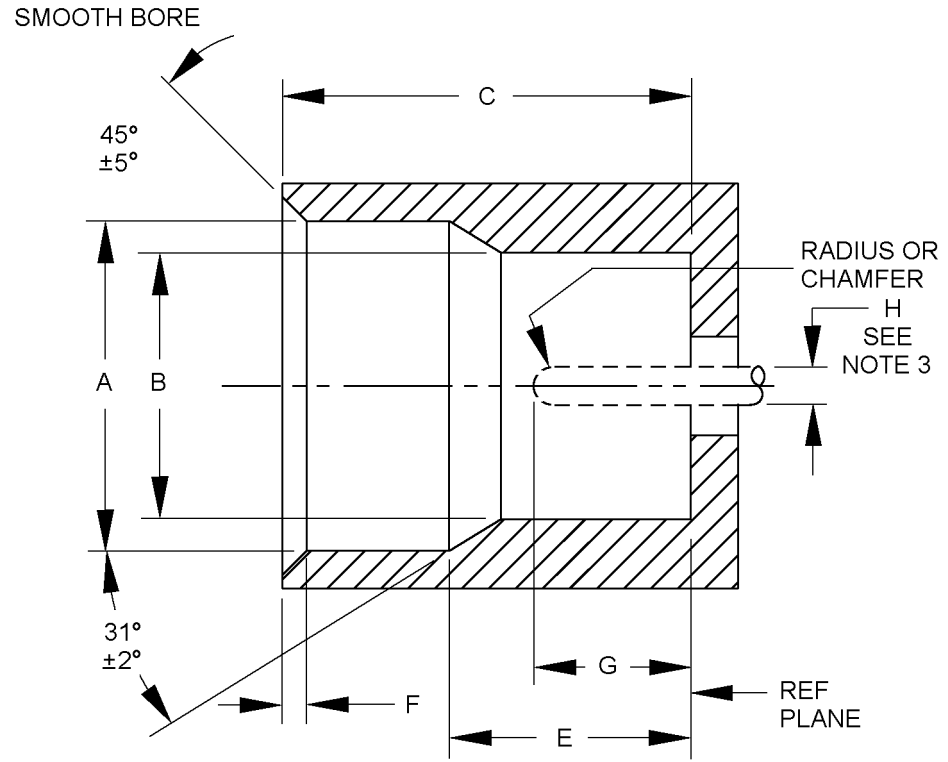

FIGURE 326-4. Interface, series SMP, pin contact, smooth bore.

MIL-STD-348B
 w/CHANGE 2

Letter	Inches (mm)	
	Minimum	Maximum
A	.139 (3.53)	.145 (3.68)
B	.124 (3.15)	.126 (3.20)
C	.108 (2.74)	.112 (2.84)
D	-----	-----
E	.073 (1.85)	.077 (1.96)
F	.003 (0.08)	.008 (0.20)
G	.045 (1.14)	.055 (1.40)
H	.014 (0.36)	.016 (0.41)

NOTES:

1. Dimensions are in inches.
2. Metric equivalents are given for information purposes only.
3. Pin may not be supplied with shroud, refer to applicable specification.

FIGURE 326-4. Interface, series SMP, pin contact, smooth bore – Continued.

MIL-STD-348B
w/CHANGE 2

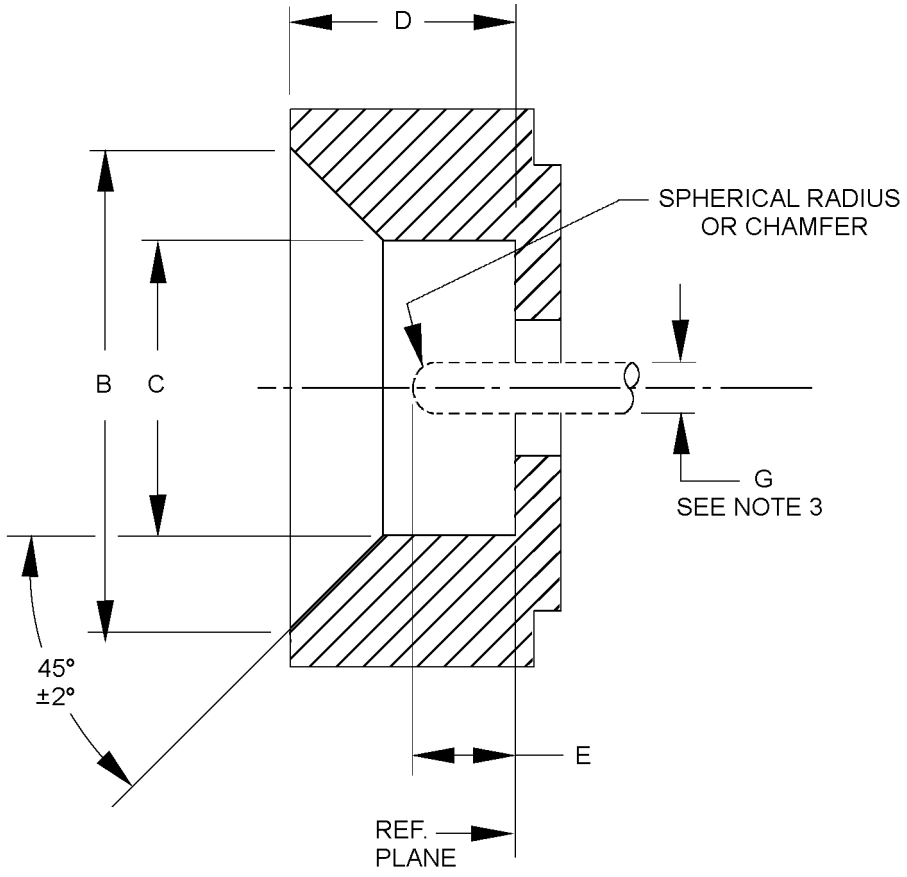

FIGURE 326-5. Interface, series SMP, pin contact, catchers mit.

MIL-STD-348B
 w/CHANGE 2

Letter	Inches (mm)	
	Minimum	Maximum
A	-----	-----
B	.212 (5.38)	.218 (5.54)
C	.124 (3.15)	.126 (3.20)
D	.108 (2.74)	.112 (2.84)
E	.045 (1.14)	.055 (1.40)
F	-----	-----
G see note 3	.014 (0.36)	.016 (.41)

NOTES:

1. Dimensions are in inches.
2. Metric equivalents are given for information purposes only.
3. Pin may not be supplied with shroud, refer to applicable specification.

FIGURE 326-5. Interface, series SMP, pin contact, catchers mit – Continued.

MIL-STD-348B
 w/CHANGE 2

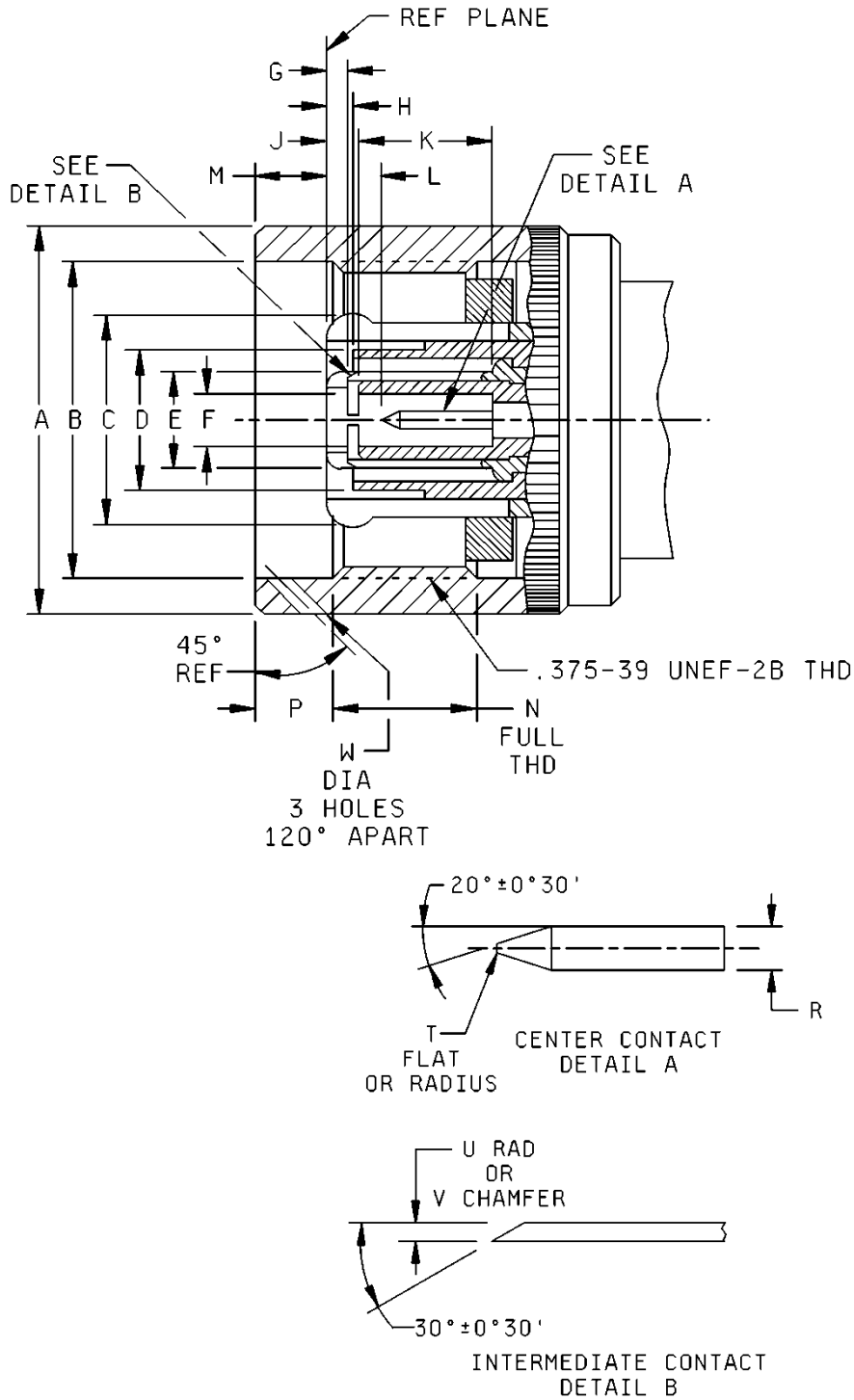

FIGURE 327-1. Interface, series DBA, pin contact.

MIL-STD-348B
 w/CHANGE 2

Ltr.	Inches (millimeter)	
	Min.	Max.
A	-----	.460 (11.68)
B	.372 (9.45)	.382 (9.70)
C	.250 (6.35)	.256 (6.50)
D	.170 (4.32)	.174 (4.42)
E	.124 (3.15)	.128 (3.25)
F	.067 (1.70)	.070 (1.78)
G	.015 (0.38)	.038 (0.97)
H	.024 (0.61)	-----
J	.009 (0.23)	.037 (0.94)
K	.168 (4.27)	-----
L	.040 (1.02)	.066 (1.68)
M	-----	.105 (2.67)
N	.156 (3.96)	-----
P	.075 (1.91)	.085 (2.16)
R	.017 (0.43)	.020 (0.51)
T	-----	.006 (0.15)
U	.005 (0.13)	.010 (0.25)
V	.004 (0.10)	.007 (0.18)
W	.027 (0.69)	-----

NOTES:

1. Metric equivalents are in parentheses.

FIGURE 327-1. Interface, series DBA, pin contact – Continued.

MIL-STD-348B
 w/CHANGE 2

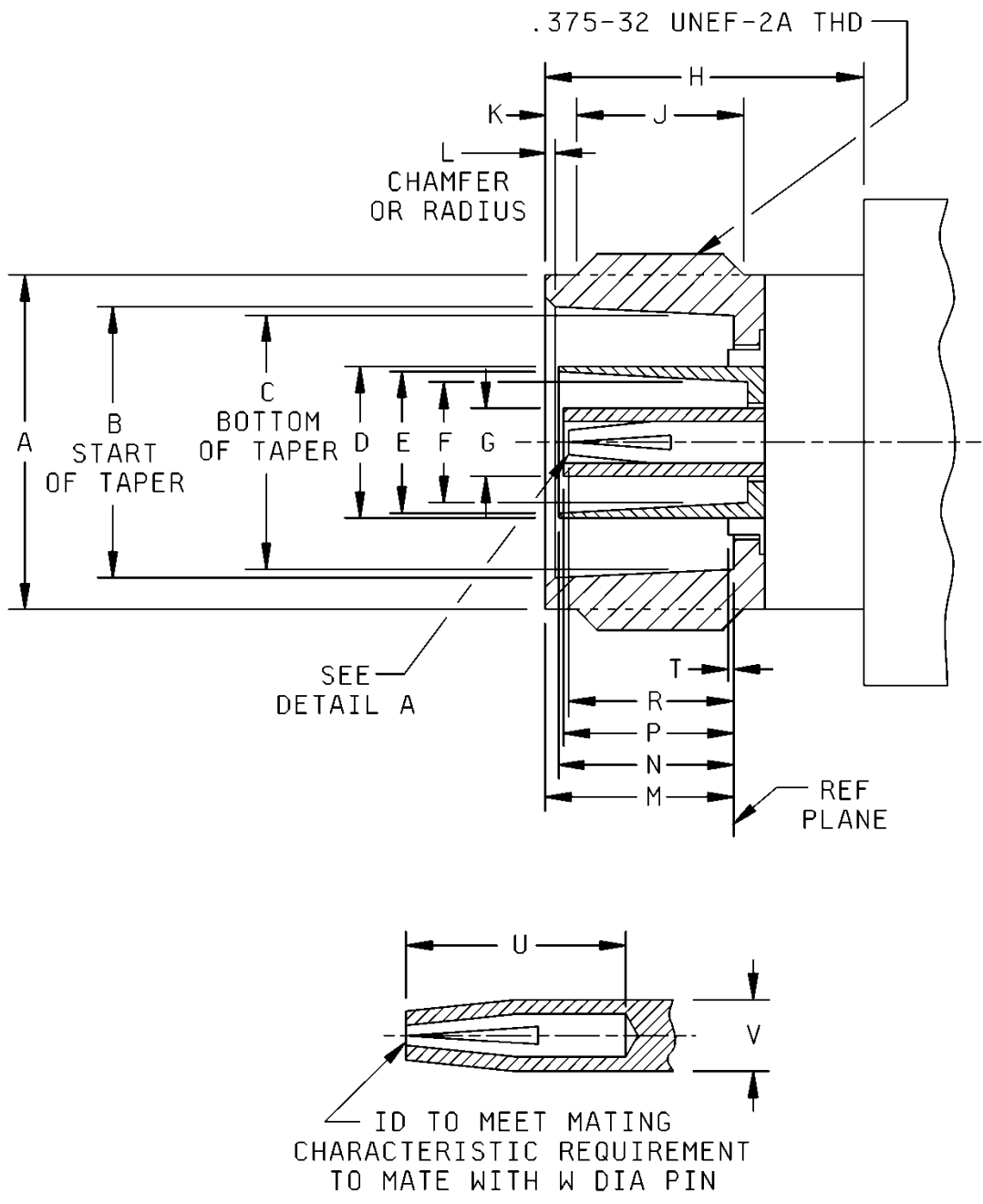

FIGURE 327-2. Interface, series DBA, socket contact.

**MIL-STD-348B
 w/CHANGE 2**

Ltr.	Inches (millimeter)	
	Min.	Max.
A	.325 (8.26)	.332 (8.43)
B	.266 (6.76)	.271 (6.88)
C	.247 (6.27)	.250 (6.35)
D	.141 (3.58)	.146 (3.71)
E	.131 (3.33)	.135 (3.43)
F	.110 (2.79)	.114 (2.90)
G	.063 (1.60)	.065 (1.65)
H	.302 (7.67)	-----
J	.150 (3.81)	-----
K	.025 (0.64)	.035 (0.89)
L	.003 (0.08)	.007 (0.18)
M	.177 (4.50)	.182 (4.62)
N	.163 (4.14)	.179 (4.55)
P	-----	.176 (4.47)
R	.148 (3.76)	.166 (4.22)
T	-----	.010 (0.25)
U	.150 (3.81)	.170 (4.32)
V	.036 (0.91)	.039 (0.99)
W	.017 (0.43)	.019 (0.48)

NOTES:

1. Metric equivalents are in parentheses.
2. When nut is biased fully forward the maximum dimension permitted is .060. When nut is biased fully back the minimum dimension is .016.

FIGURE 327-2. Interface, series DBA, socket contact - Continued.

MIL-STD-348B
 w/CHANGE 2

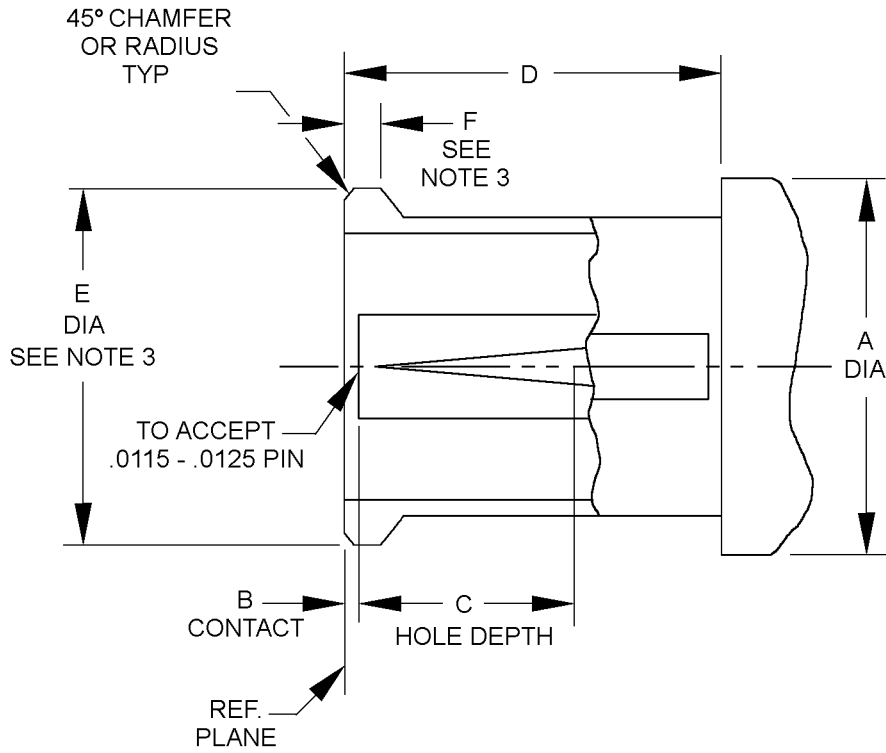

Letter	Inches (mm)	
	Minimum	Maximum
A dia.	-----	.110 (2.79)
B	.000 (0.00)	.008 (0.20)
C	.050 (1.27)	-----
D	.072 (1.83)	-----
E dia.	-----	.095 (2.41)
F	-----	.023 (0.58)

NOTES:

1. Dimensions are in inches.
2. Metric equivalents are given for information purposes only.
3. Features to meet mechanical/electrical requirements when mated with SMPM pin interface.

FIGURE 328-1. Interface, series SMPM, socket contact.

MIL-STD-348B
 w/CHANGE 2

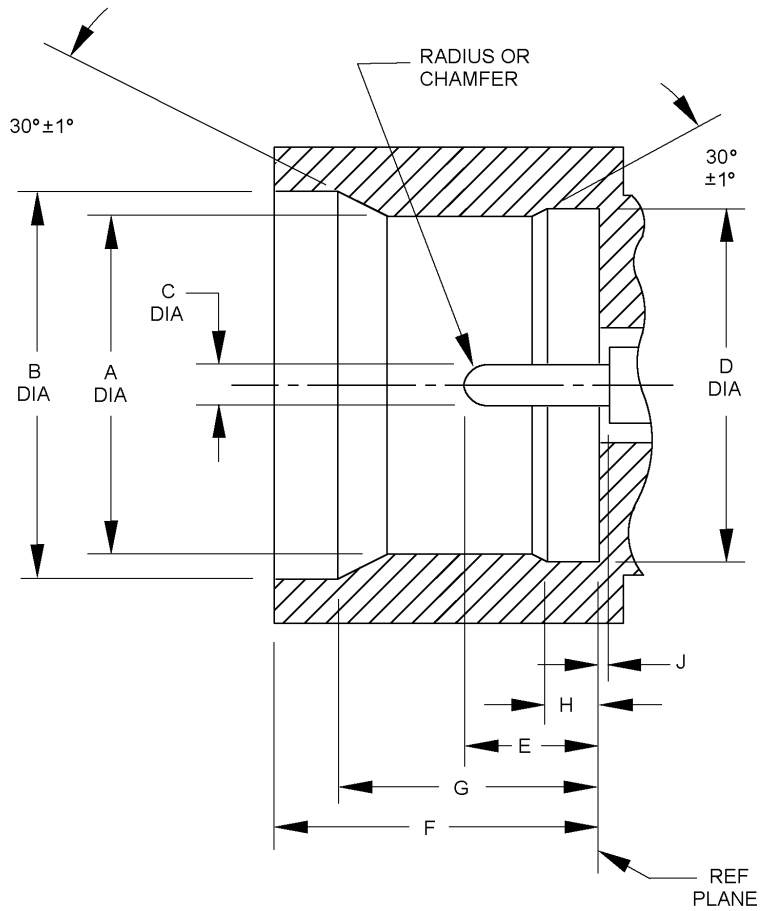

Letter	Inches (mm)	
	Minimum	Maximum
A dia.	.083 (2.11)	.085 (2.16)
B dia.	.111 (2.82)	.115 (2.92)
C dia.	.0115 (0.29)	.0125 (0.32)
D dia.	.086 (2.18)	.088 (2.24)
E	.030 (0.76)	.045 (1.14)
F	.082 (2.08)	.084 (2.13)
G	.062 (1.57)	.072 (1.83)
H	.021 (0.53)	.023 (0.58)
J	.000 (0.00)	-----

NOTES:

1. Dimensions are in inches.
2. Metric equivalents are given for information purposes only.

FIGURE 328-2. Interface, series SMPM, pin contact, (full detent).

MIL-STD-348B
 w/CHANGE 2

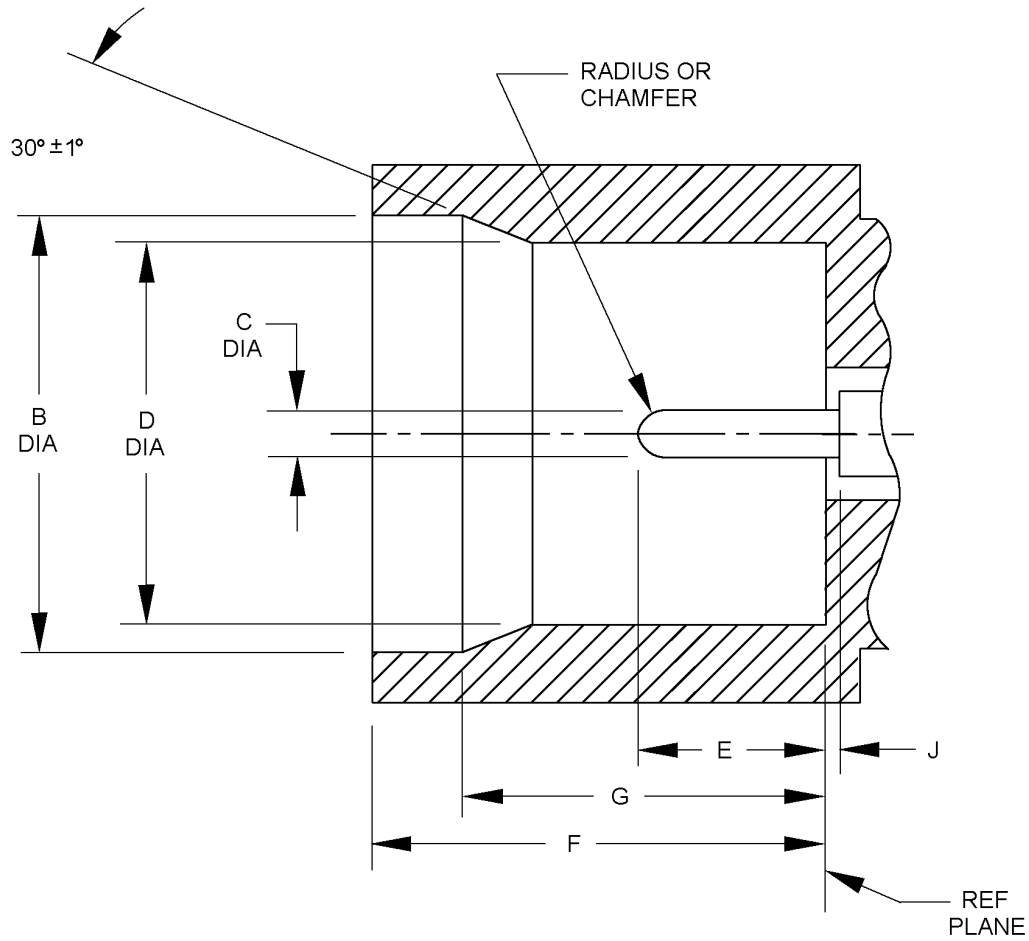

Letter	Inches (mm)	
	Minimum	Maximum
A dia.	-----	-----
B dia.	.111 (2.82)	.115 (2.92)
C dia.	.0115 (0.29)	.0125 (0.32)
D dia.	.086 (2.18)	.088 (2.24)
E	.030 (0.76)	.045 (1.14)
F	.082 (2.08)	.084 (2.13)
G	.062 (1.57)	.072 (1.83)
J	.000 (0.00)	-----

NOTES:

1. Dimensions are in inches.
2. Metric equivalents are given for information purposes only.

FIGURE 328-3. Interface, series SMPM, pin contact (smooth bore).

**MIL-STD-348B
 w/CHANGE 2**

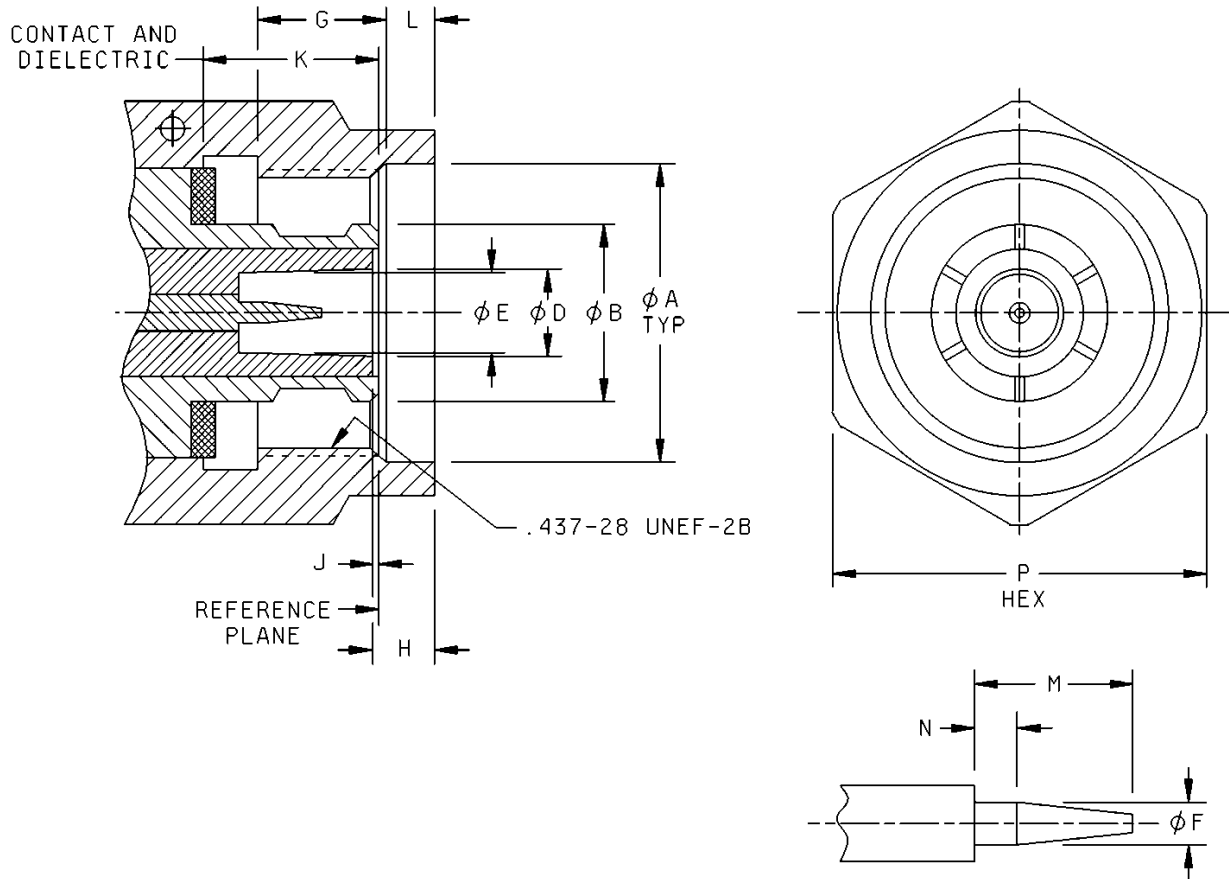

Letter	Inches (mm)	
	Minimum	Maximum
A dia.	.440 (11.18)	-----
B dia.	.242 (6.15)	.246 (6.25)
D dia.	.124 (3.15)	.126 (3.20)
E dia.	.114 (2.90)	.116 (2.95)
F dia.	.0335 (0.851)	.0345 (0.876)
G	.175 (4.45)	.215 (5.46)
H	.074 (1.88)	.096 (2.44)
J	.000 (0.00)	.004 (0.10)
K	.209 (5.31)	.212 (5.38)
L	.065 (1.65)	.085 (2.16)
M	.120 (3.05)	.130 (3.30)
N	.030 (0.76)	.040 (1.02)
P	.562 (14.27)	

NOTES:

1. When fully engage, the two reference planes must coincide with metal to metal contact.
2. Metric equivalents are given for information purposes only.

FIGURE 329-1. Interface, series TK, pin contact, slotted outer contact.

MIL-STD-348B
w/CHANGE 2

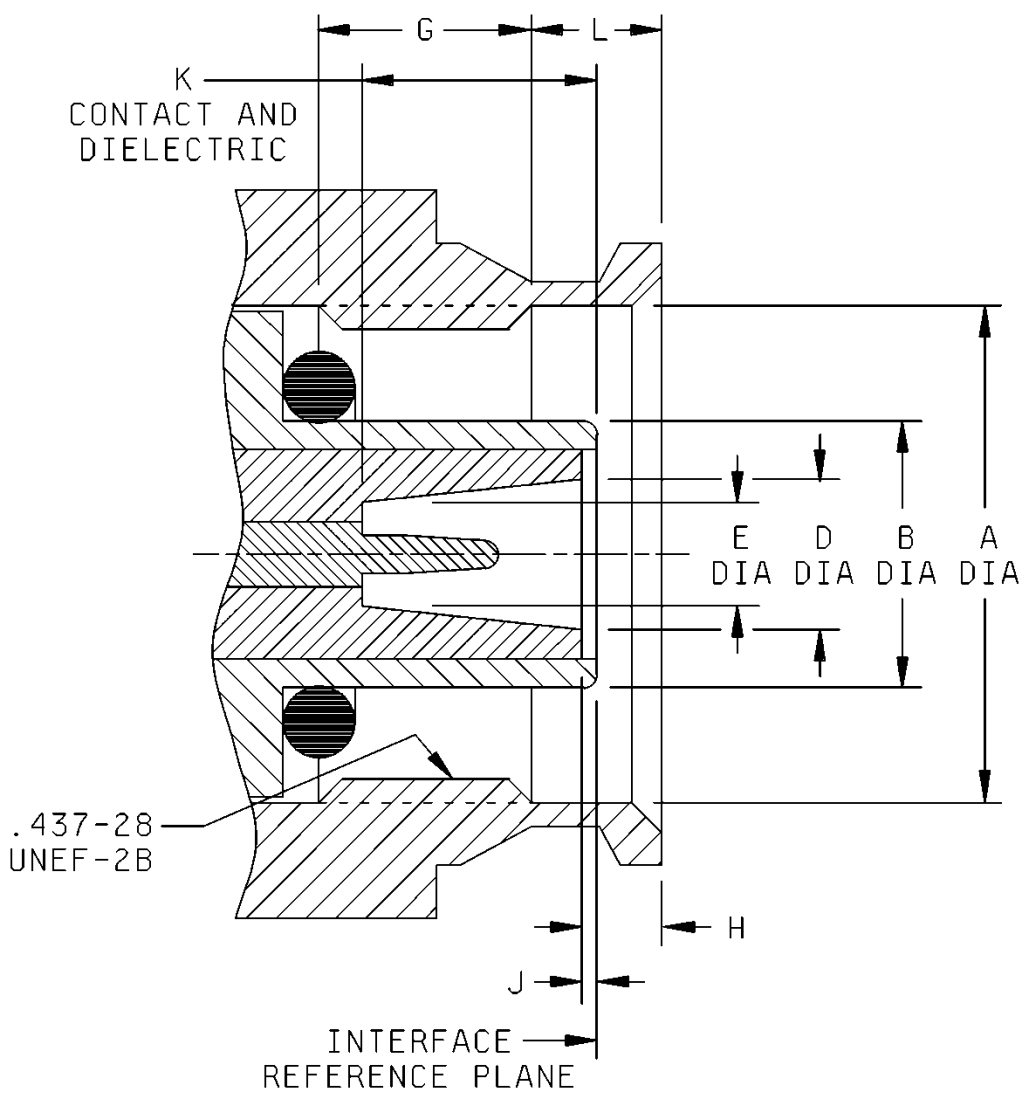
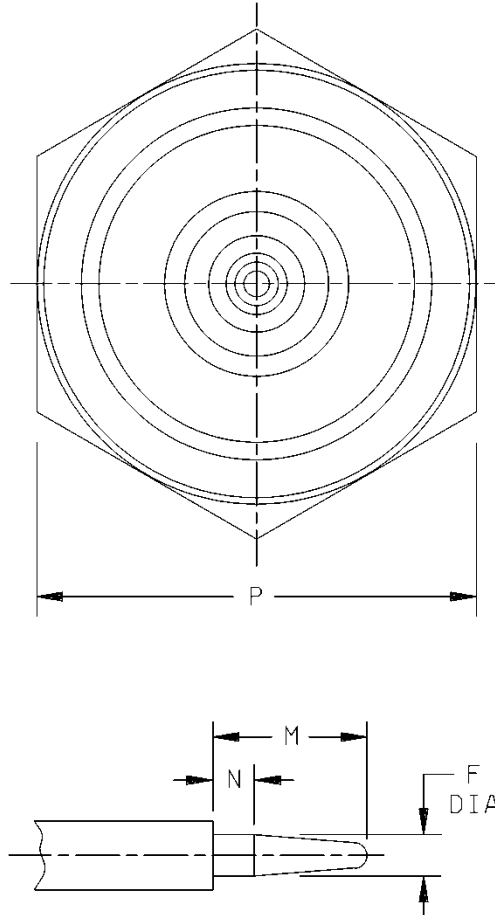

FIGURE 329-1a. Interface, series TK, pin contact, unslotted outer contact.

MIL-STD-348B
 w/CHANGE 2



Letter	Inches (mm)	
	Minimum	Maximum
A	.440 (11.18)	-----
B	.2370 (6.020)	.2380 (6.045)
D	.124 (3.15)	.126 (3.20)
E	.114 (2.90)	.116 (2.95)
F	.0335 (0.851)	.0345 (0.876)
G	.173 (4.39)	.215 (5.46)
H	.074 (1.88)	.095 (2.44)
J	.000 (0.00)	.004 (0.10)
K	.209 (5.31)	.212 (5.38)
L	.063 (1.60)	.085 (2.16)
M	.120 (3.05)	.130 (3.30)
N	.030 (0.76)	.040 (1.02)

FIGURE 329-1a. Interface, series TK, pin contact, unslotted outer contact – Continued.

MIL-STD-348B
 w/CHANGE 2

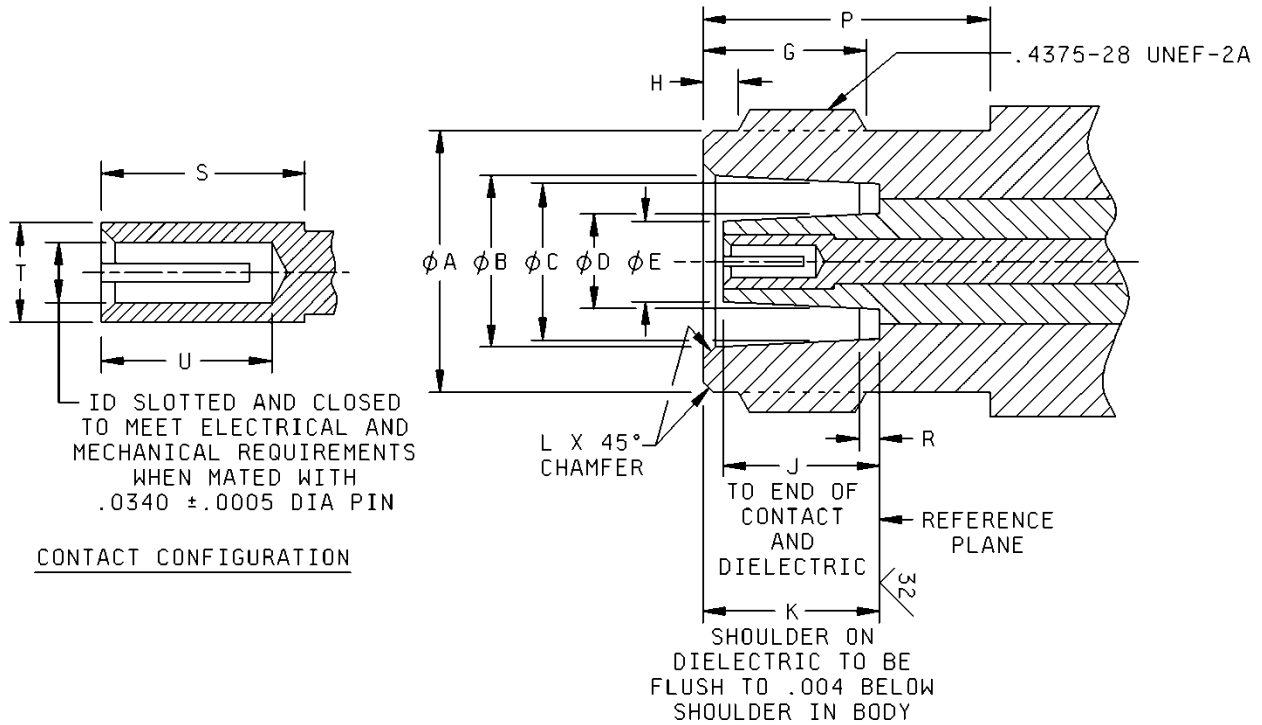

Letter	Inches (mm)	
	Minimum	Maximum
A dia.	.365 (9.27)	.375 (9.53)
B dia.	.250 (6.35)	.255 (6.48)
C dia.	.239 (6.07)	.241 (6.12)
D dia.	.122 (3.10)	.124 (3.15)
E dia.	.112 (2.84)	.114 (2.90)
G	.235 (5.97)	.245 (6.22)
H	.055 (1.40)	.065 (1.65)
J	.205 (5.21)	.208 (5.28)
K	.227 (5.77)	.233 (5.92)
L	.010 (0.25)	.020 (0.51)
P	.340 (8.64)	-----
R	.025 (0.64)	.035 (0.89)
S	.120 (3.05)	.130 (3.30)
T	.0567 (1.440)	.0577 (1.466)
U	.145 (3.68)	-----

NOTES:

1. When fully engaged, the two reference planes must coincide with metal to metal contact.
2. Metric equivalents are given for information purposes only.

FIGURE 329-2. Interface, series TK. socket contact.

MIL-STD-348B
 w/CHANGE 2

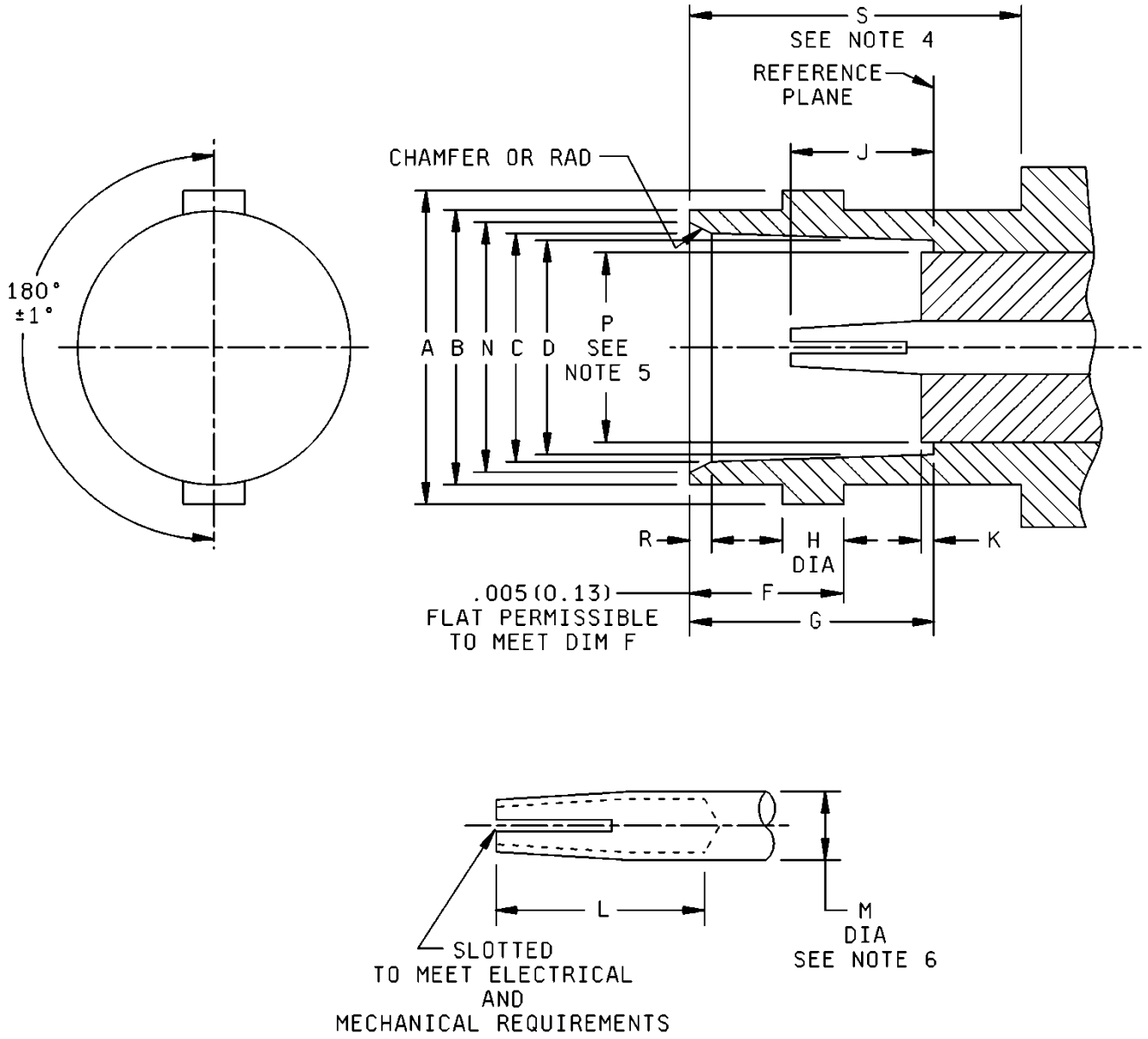

FIGURE 330-1. Interface, series BNC, socket contact, 75 ohm.

MIL-STD-348B
 w/CHANGE 2

Dim Ltr	Inches (mm)	
	Minimum	Maximum
A	.432 (10.97)	.436 (11.07)
B	.378 (9.60)	.382 (9.70)
C	.327 (8.31)	.333 (8.46)
D	.319 (8.10)	.321 (8.15)
F	.204 (5.18)	.208 (5.28)
G	.327(8.31)	.335 (8.51)
H	.075 (1.91)	.081 (2.06)
J	.186 (4.72)	.206 (5.23)
K	-----	.006 (0.15)
L	.195 (4.95)	-----
M	.081 (2.06)	.087 (2.21)
N	.346 (8.79)	.356 (9.04)
P	-----	.256 (6.50)
R	.015 (0.38)	.030 (0.76)
S	.414 (10.52)	-----

NOTES:

1. Dimensions are in inches. Metric equivalents are in parentheses.
2. Metric equivalents are given for general information only.
3. This interface shall meet the gauge requirements as specified in DSCC drawing or specification.
4. Clearance for mating connector coupling nut.
5. "P" dimension applies to that portion (if applicable) of dielectric which extends beyond references planes by dimension K.
6. "M" applies only over length "L".

FIGURE 330-1. Interface, series BNC, socket contact, 75 ohm – Continued.

MIL-STD-348B
 w/CHANGE 2

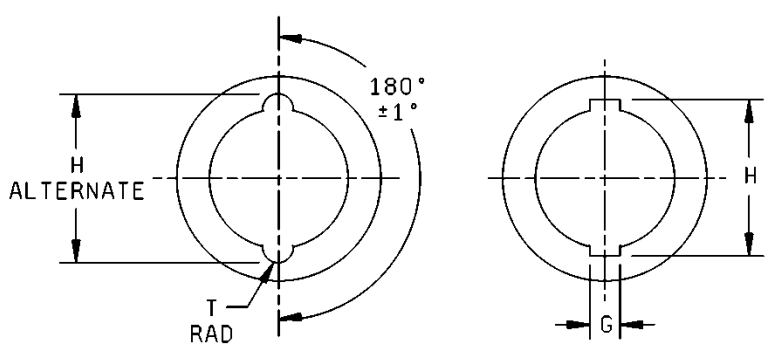
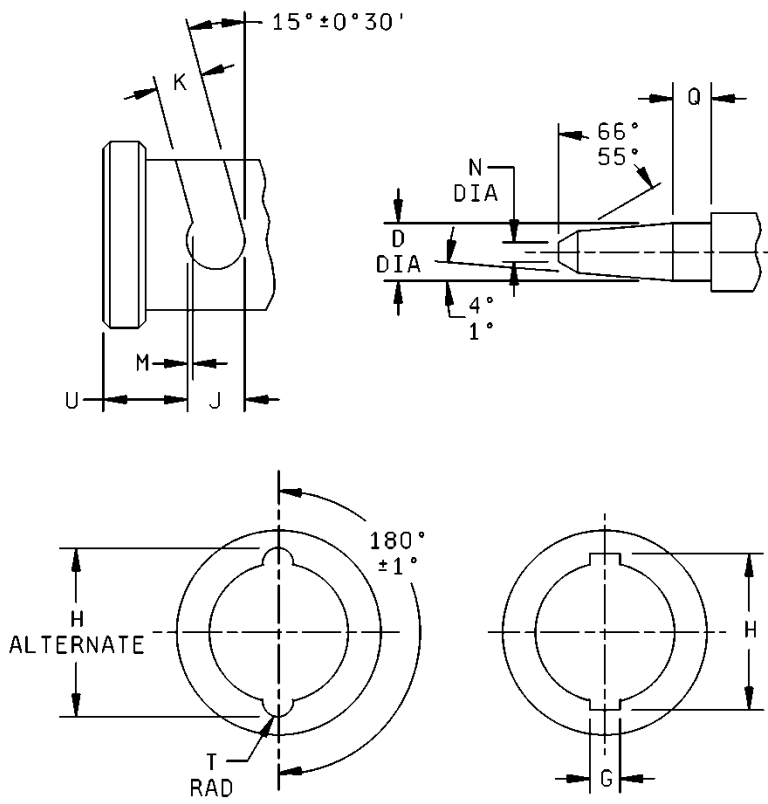
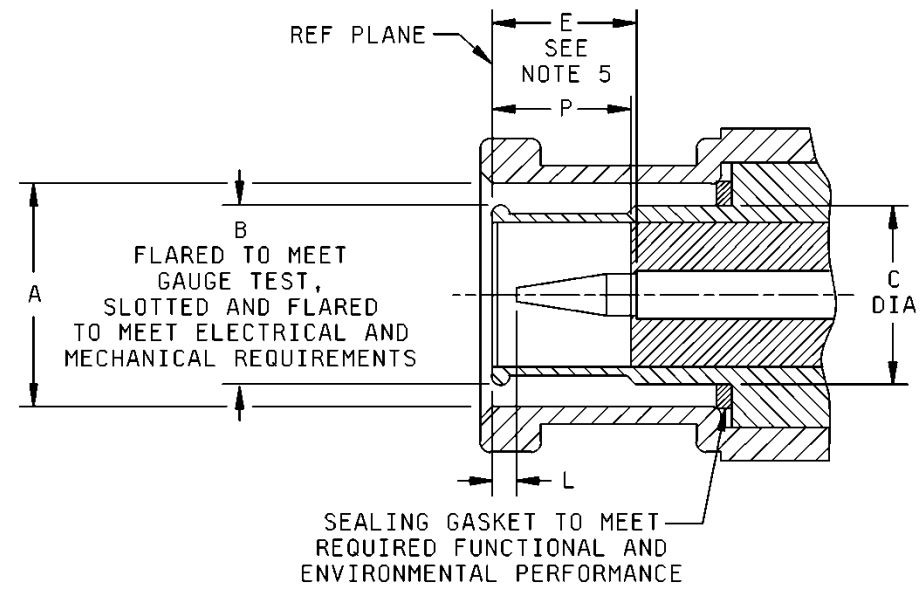

FIGURE 330-2. Interface, series BNC, pin contact, 75 ohm.

MIL-STD-348B
 w/CHANGE 2

Dim Ltr	Inches (mm)	
	Minimum	Maximum
A	.385 (9.78)	.390 (9.91)
B	Gauge test	
D	.052 (1.32)	.054 (1.37)
E	.210 (5.33)	.230 (5.84)
G	.091 (2.31)	.097 (2.46)
H	.463 (11.76)	.473 (12.01)
H alternate	.394 (10.01)	.400 (10.16)
J	.124 (3.15)	-----
K	.091 (2.31)	.097 (2.46)
L	.003 (0.08)	-----
M	.018 (0.46)	.022 (0.56)
N	-----	.025 (0.64)
P	.208 (5.28)	-----
Q	.078 (1.98)	-----
T	.045 (1.14)	.049 (1.24)
U	.180 (4.57)	.184 (4.67)

NOTES:

1. Dimensions are in inches. Metric equivalents are in parentheses.
2. Metric equivalents are given for general information only.
3. In the mated condition, the longitudinal force of the spring of the coupling mechanism shall exceed the pressure exerted by the sealing gasket by an amount necessary to insure butting of the outer contacts at the reference plane.
4. This interface shall meet the gauge requirements as specified.

FIGURE 330-2. Interface, series BNC, pin contact, 75 ohm – Continued.

MIL-STD-348B
 w/CHANGE 2

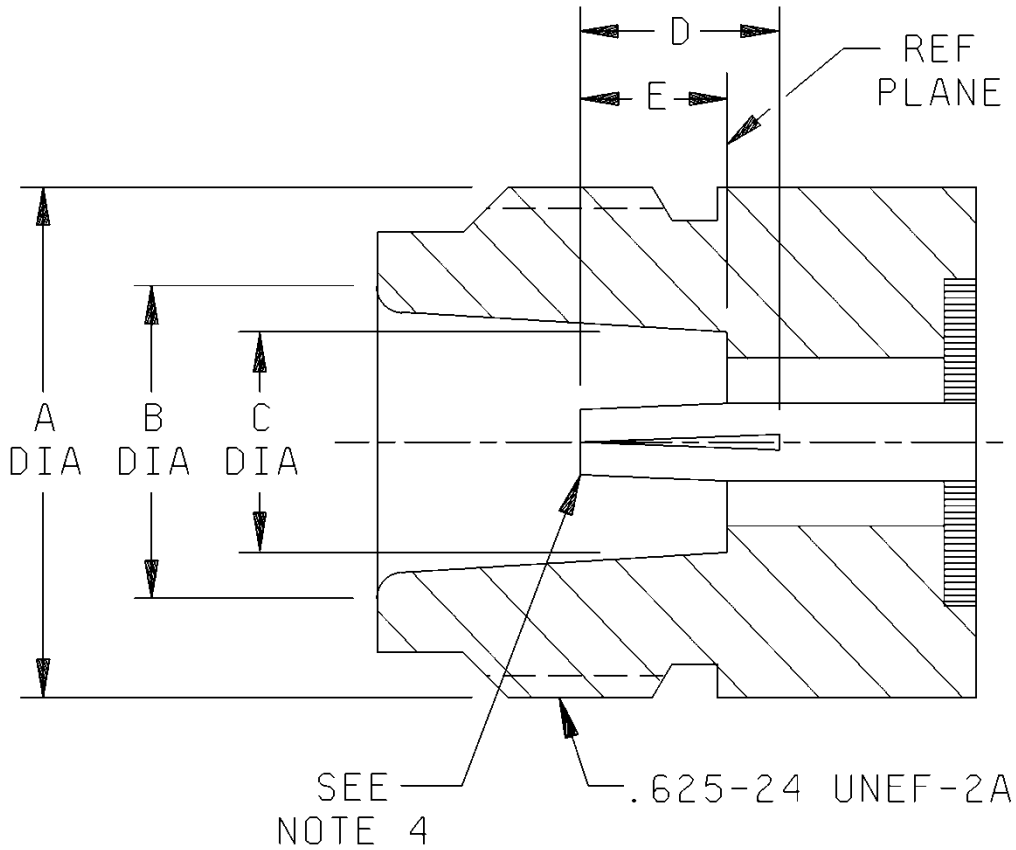

Letter	Inches (mm)	
	Minimum	Maximum
A	-----	.627 (15.93)
B	.336 (8.53)	.344 (8.74)
C	.316 (8.03)	.320 (8.13)
D	.210 (5.33)	-----
E	.187 (4.75)	.207 (5.26)

NOTES:

1. Dimensions are in inches. Metric equivalents are in parentheses.
2. Metric equivalents are given information only.
3. Utilizes standard 50Ω body with 75Ω contact/air dielectric configuration.
4. ID to meet contact resistance, mating characteristics and connector durability when mated with a $.036/.037$ (0.091/0.094 mm).

FIGURE 331-1. Interface, series N, socket contact, 75 ohm.

MIL-STD-348B
 w/CHANGE 2

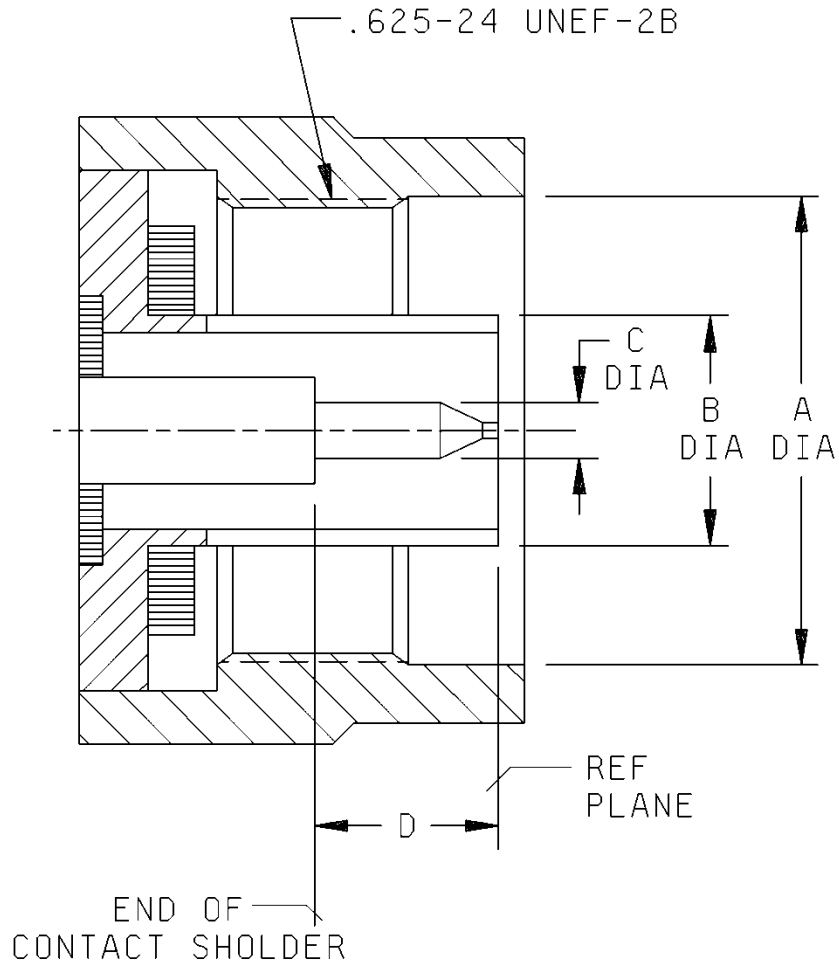

Letter	Inches (mm)	
	Minimum	Maximum
A	.630 (16.00)	-----
B	-----	.330 (8.38)
C	.036 (0.91)	.037 (0.94)
D	.210 (5.33)	.230 (5.84)

NOTES:

1. Dimensions are in inches. Metric equivalents are in parentheses.
2. Metric equivalents are given for information only.
3. Utilizes standard 50Ω body with 75Ω contact/air dielectric configuration.

FIGURE 331-2. Interface, series N, pin contact, 75 ohm.

MIL-STD-348B
 w/CHANGE 2

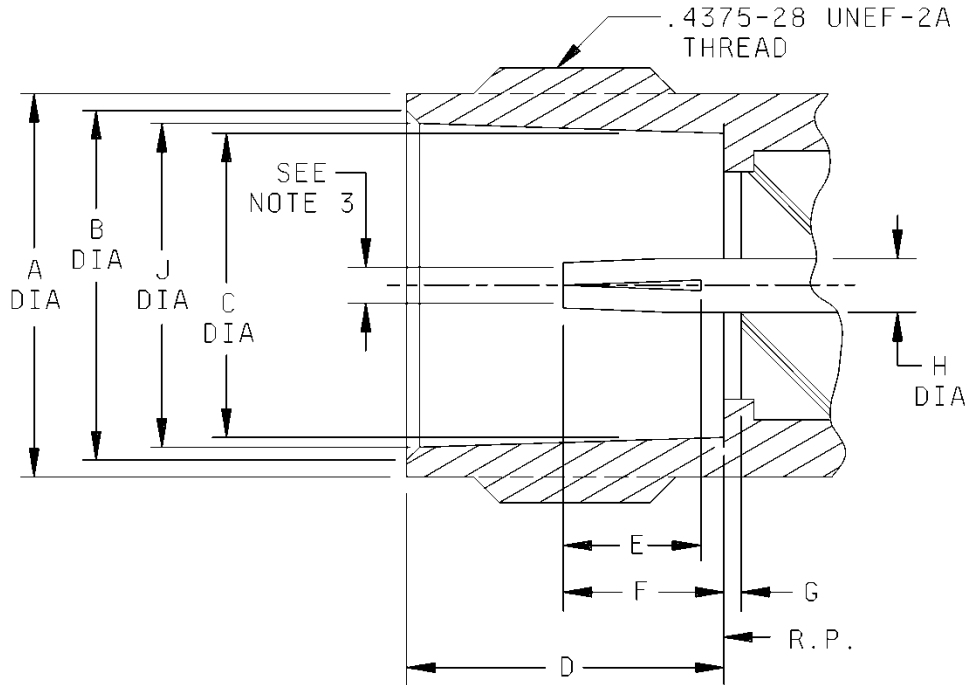

Letter	Inches (mm)	
	Minimum	Maximum
A	.378 (9.60)	.381 (9.68)
B	.346 (8.79)	.356 (9.04)
C	.319 (8.10)	.321 (8.15)
D	.327 (8.31)	.335 (8.51)
E	.195 (4.95)	-----
F	.186 (4.72)	.206 (5.23)
G	.000 (0.00)	-----
H	.081 (2.06)	.087 (2.21)
J	.327 (8.31)	.333 (8.46)

NOTES:

1. Dimensions are in inches. Metric equivalents are in parentheses.
2. Metric equivalents are given information only.
3. ID to meet contact resistance, mating characteristics and connector durability when mated with a .052/.054 (0.091/0.094 mm).
4. Utilizes standard 50Ω body with 75Ω contact/air dielectric configuration.

FIGURE 332-1. Interface, series TNC, socket contact, 75 ohm.

**MIL-STD-348B
 w/CHANGE 2**

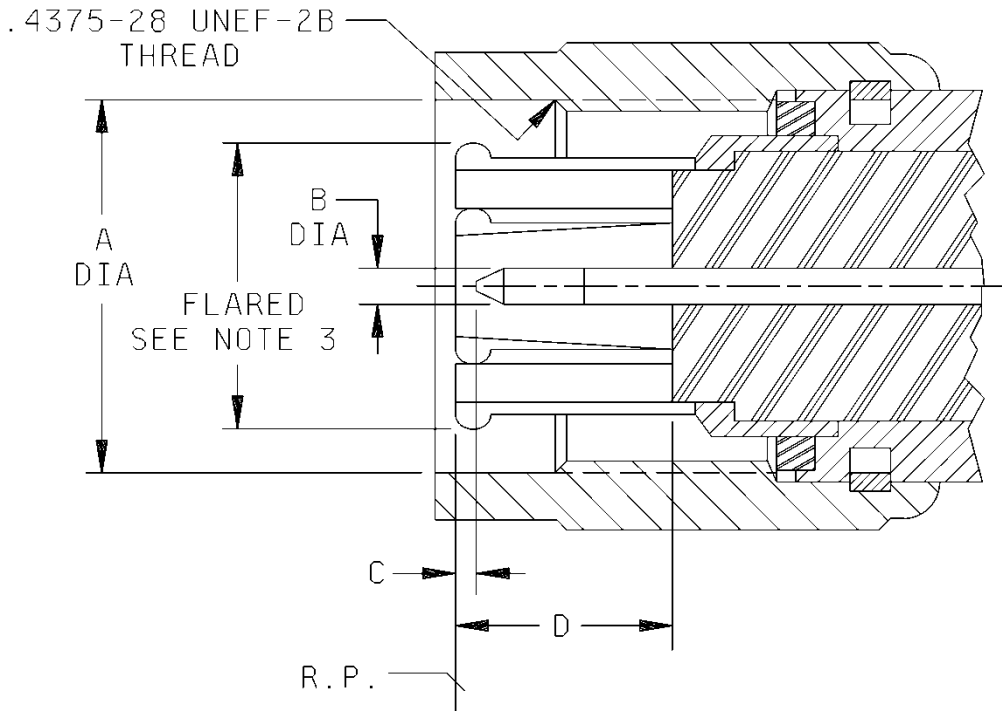

Letter	Inches (mm)	
	Minimum	Maximum
A	.440 (11.18)	-----
B	.052 (1.32)	.054 (1.37)
C	.003 (0.08)	.040 (1.02)
D	.208 (5.28)	-----

NOTES:

1. Dimensions are in inches. Metric equivalents are in parentheses.
2. Metric equivalents are given for information only.
3. Utilizes standard 50Ω body with 50Ω contact dia./75Ω air dielectric configuration. See standard 50 ohm TNC pin contact interface in this military standard.

FIGURE 332-2. Interface, series TNC, pin contact, 75 ohm.

MIL-STD-348B
w/CHANGE 2

SECTION 400

Interface Dimensions for MIL-DTL-39012, MIL-DTL-55339 and MIL-DTL-83517

Section 401	Series C
Section 402	Series N
Section 403	Series SC
Section 404	Series BNC
Section 405	Series SMA
Section 406	Series TNC
Section 407	Series SMB
Section 408	Series SMC
Section 409	Series QNC
Section 410	Series QSC

MIL-STD-348B
 w/CHANGE 2

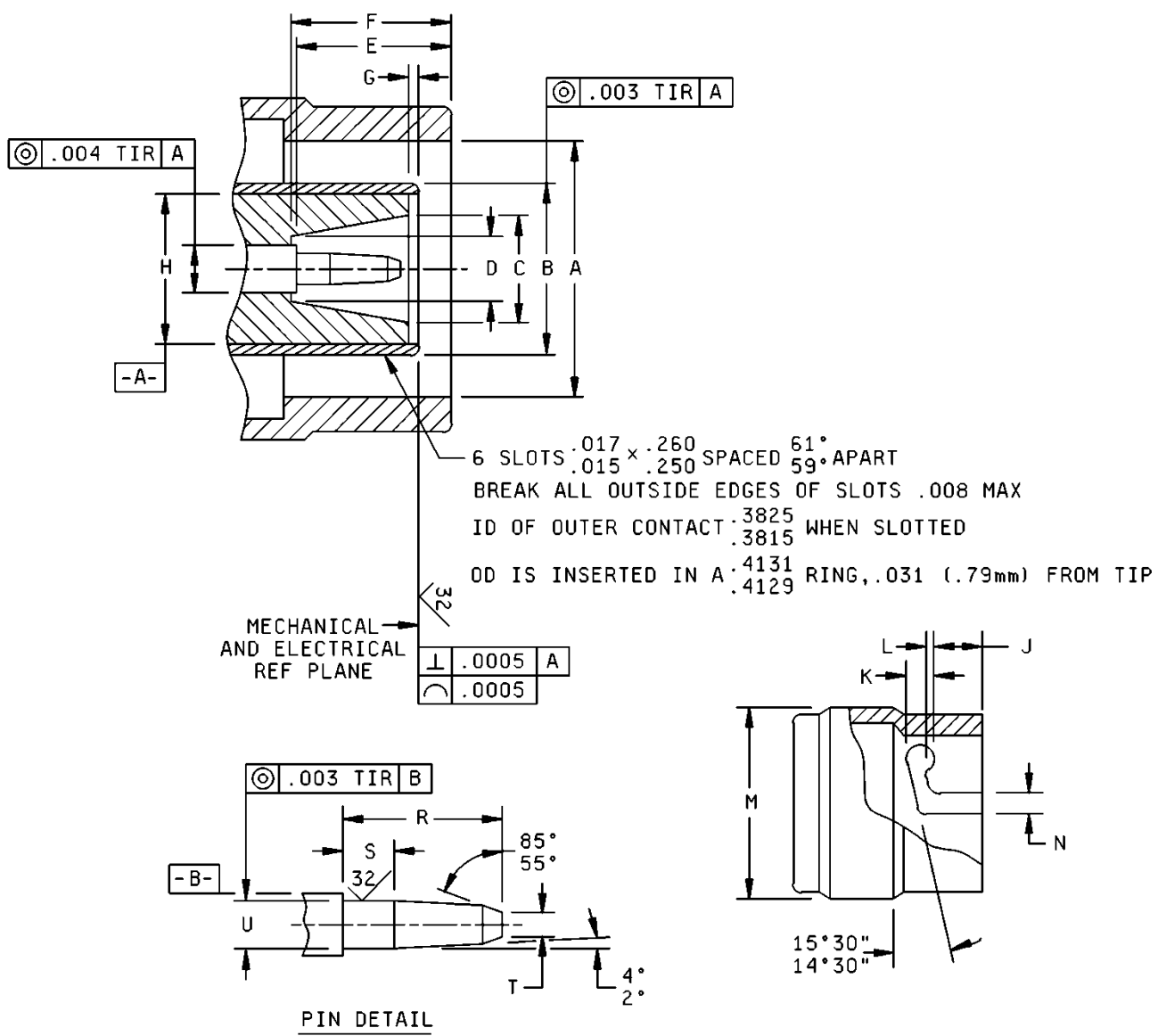

FIGURE 401-1. Interface test connector, series C, pin contact.

MIL-STD-348B
 w/CHANGE 2

Dim Ltr	Inches (mm)	
	Minimum	Maximum
A	.543 (13.79)	.549 (13.94)
B	.412 (10.46)	.414 (10.52)
C	.276 (7.01)	.280 (7.11)
D	.194 (4.93)	.198 (5.03)
E	.307 (7.80)	.311 (7.90)
F	.309 (7.85)	.318 (8.08)
G	.007 (0.18)	.013 (0.33)
H	.3889 (9.878)	.3897 (9.898)
J	.103 (2.62)	.113 (2.87)
K	.131 (3.33)	.141 (3.58)
L	.010 (0.25)	.018 (0.46)
M	-----	.785 (19.94)
N	.105 (2.67)	.114 (2.90)
R	.301 (7.65)	.308 (7.82)
S	.093 (2.36)	.103 (2.62)
T	.041 (1.04)	.051 (1.30)
U	.0900 (2.29)	.0921 (2.34)

FIGURE 401-1. Interface test connector, series C, pin contact – Continued.

MIL-STD-348B
 w/CHANGE 2

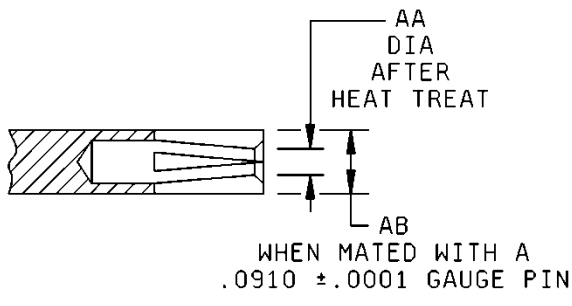
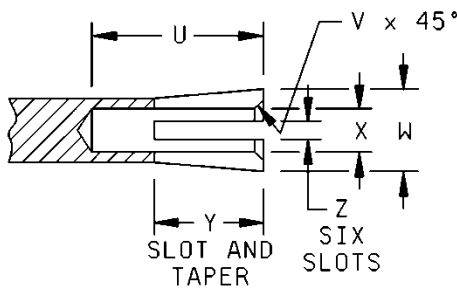
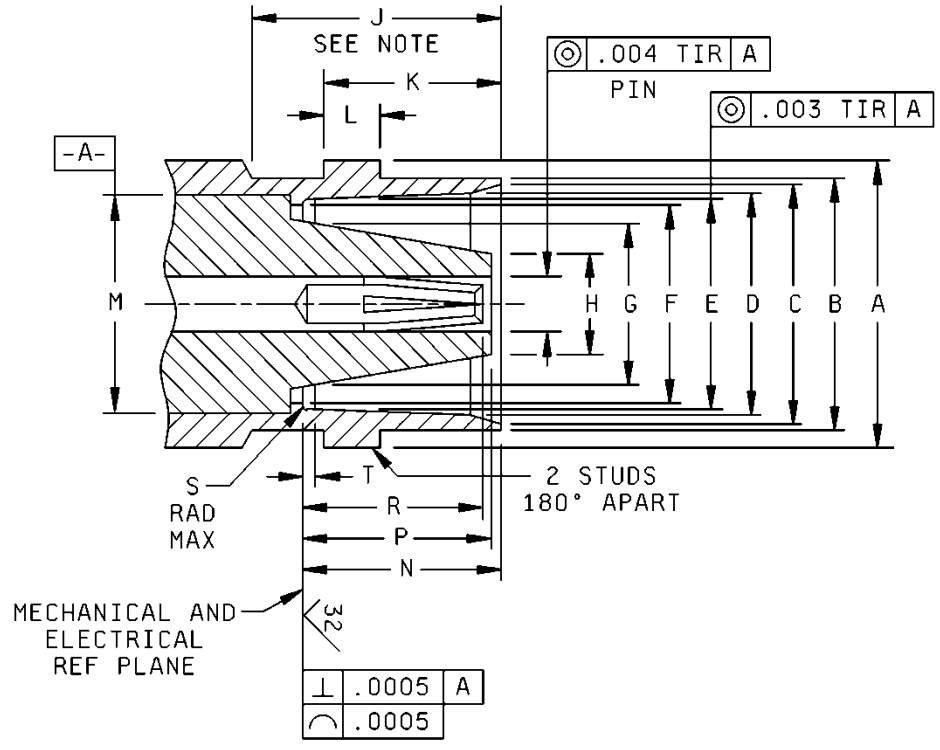

DETAIL OF INNER CONTACT

FIGURE 401-2. Interface test connector, series C, socket contact.

MIL-STD-348B
 w/CHANGE 2

Dim Ltr	Inches (mm)	
	Minimum	Maximum
A	.590 (14.99)	.600 (15.24)
B	.530 (13.46)	.540 (13.72)
C	.485 (12.32)	.495 (12.57)
D	.440 (11.18)	.450 (11.43)
E	.411 (10.44)	.415 (10.54)
F	.354 (8.99)	.358 (9.09)
G	.268 (6.81)	.272 (6.91)
H	.188 (4.78)	.190 (4.83)
J	.495 (12.57)	-----
K	.277 (7.04)	.283 (7.19)
L	.088 (2.24)	.098 (2.49)
M	.3889 (9.878)	.3897 (9.898)
N	.334 (8.48)	.338 (8.59)
P	.303 (7.70)	.309 (7.85)
R	.297 (7.54)	.305 (7.75)
S	-----	.004 (0.10)
T	.020 (0.51)	.040 (1.02)
U	.306 (7.77)	-----
V	.004 (0.10)	.011 (0.28)
W	.1314 (3.34)	.1328 (3.37)
X	.0989 (2.512)	.0991 (2.517)
Y	.240 (6.10)	.260 (6.60)
Z	.0095 (0.241)	.0125 (0.317)
AA	.085 (2.16)	.088 (2.24)
AB	.1232 (3.129)	.1288 (3.271)

NOTE: Clearance for mating connector coupling nut.

FIGURE 401-2. Interface test connector, series C, socket contact - Continued.

MIL-STD-348B
w/CHANGE 2

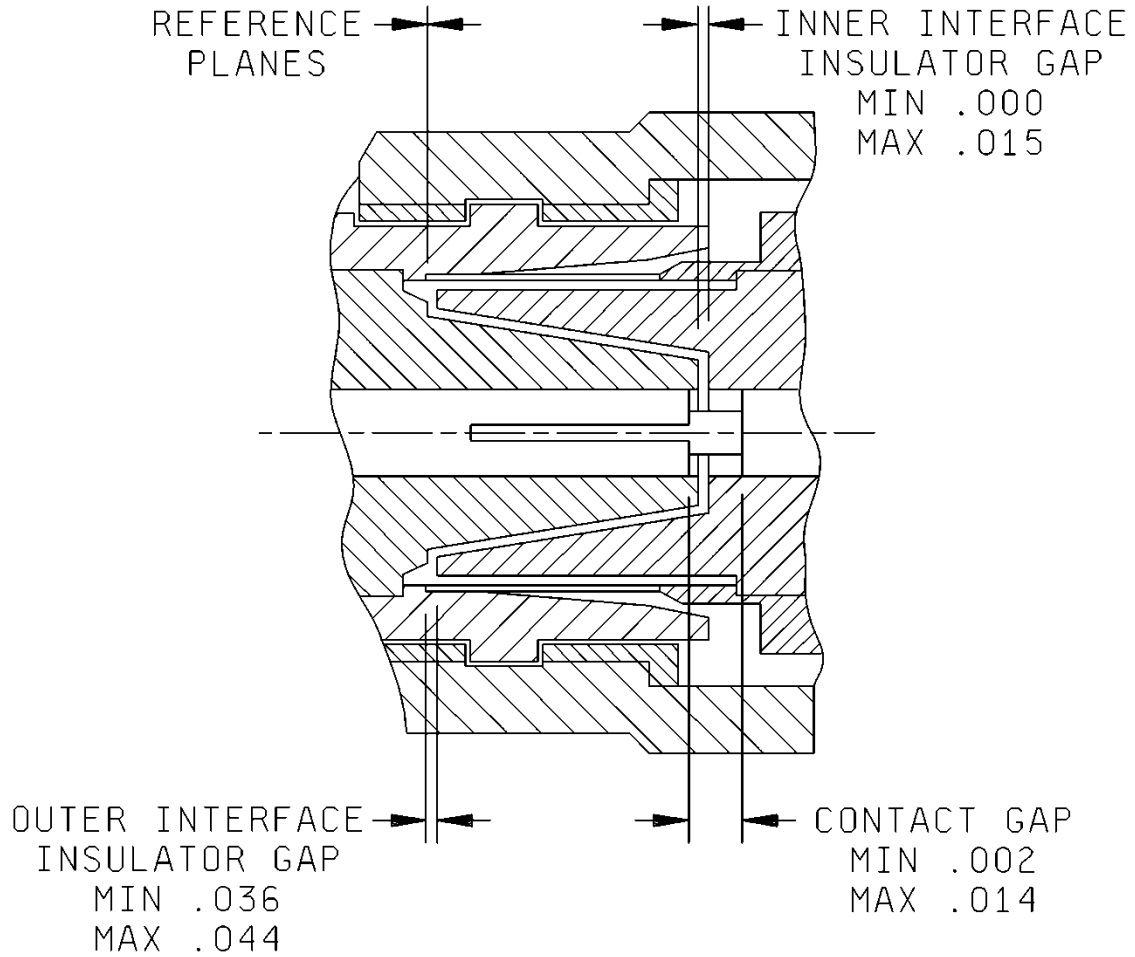

Inches (mm)	
.002	(0.05)
.014	(0.36)
.015	(0.38)
.036	(0.91)
.044	(1.12)

FIGURE 401-3. Interface, mated test connector, series C.

MIL-STD-348B
 w/CHANGE 2

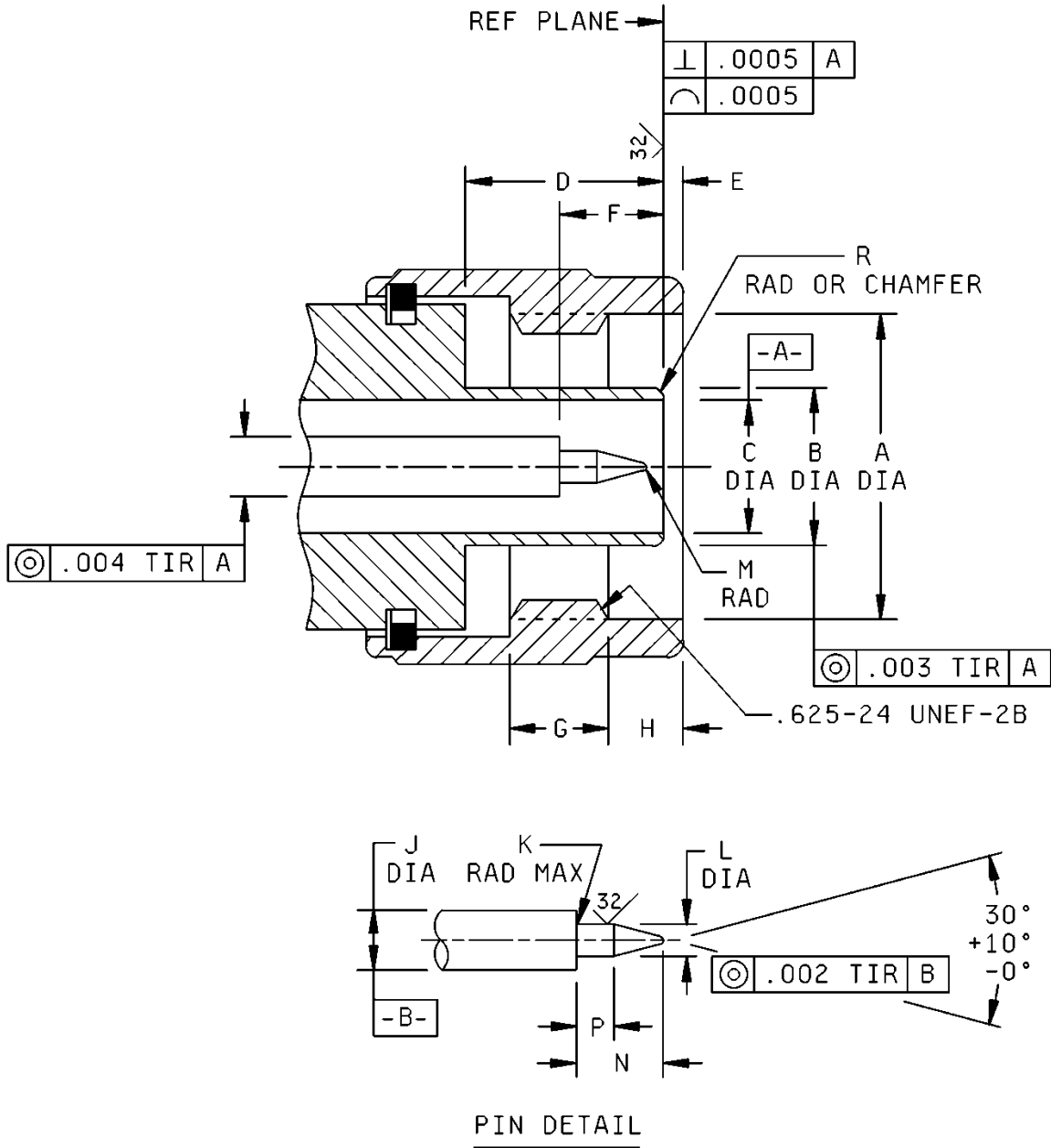

FIGURE 402-1. Interface, test connector, series N, pin contact.

**MIL-STD-348B
 w/CHANGE 2**

Dim Ltr	Inches (mm)	
	Minimum	Maximum
A	.630 (0.16)	-----
B	.3140 (7.98)	.3165 (8.04)
C	.2753 (6.99)	.2759 (7.01)
D	.362 (9.19)	.372 (9.45)
E	.011 (0.28)	.051 (1.30)
F	.208 (5.28)	.211 (5.36)
G	.177 (4.50)	.197 (5.00)
H	.158 (4.01)	.168 (4.27)
J	.1194 (3.03)	.1200 (3.05)
K	-----	.003 (0.08) Max. Rad
L	.0644 (1.64)	.0656 (1.67)
M	.010 (0.25)	.030 (0.76)
N	.178 (4.52) Reference	
P	.070 (1.78)	.080 (2.03)
R	.005 (0.13)	.008 (0.20)

FIGURE 402-1. Interface, test connector, series N, pin contact – Continued.

MIL-STD-348B
 w/CHANGE 2

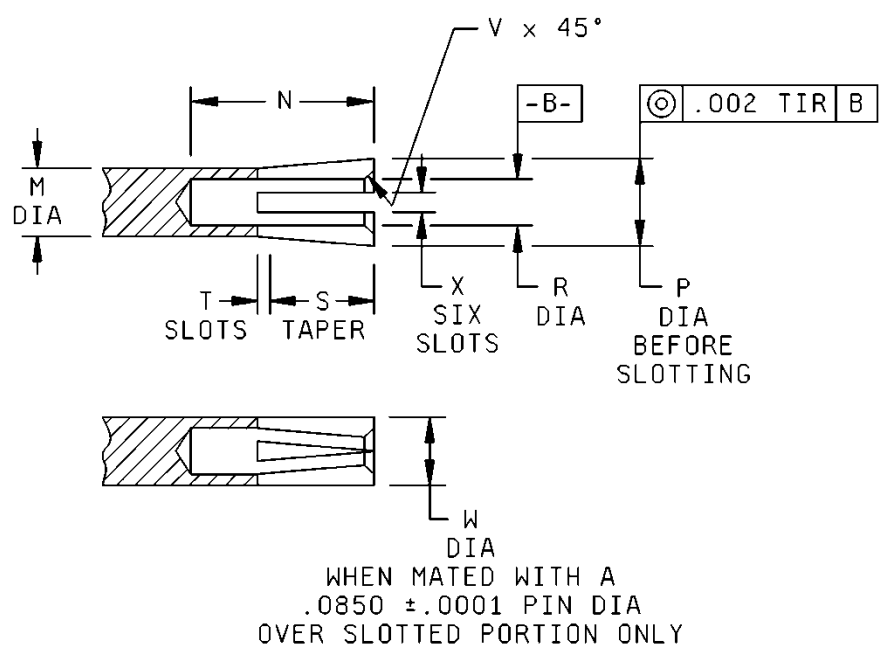
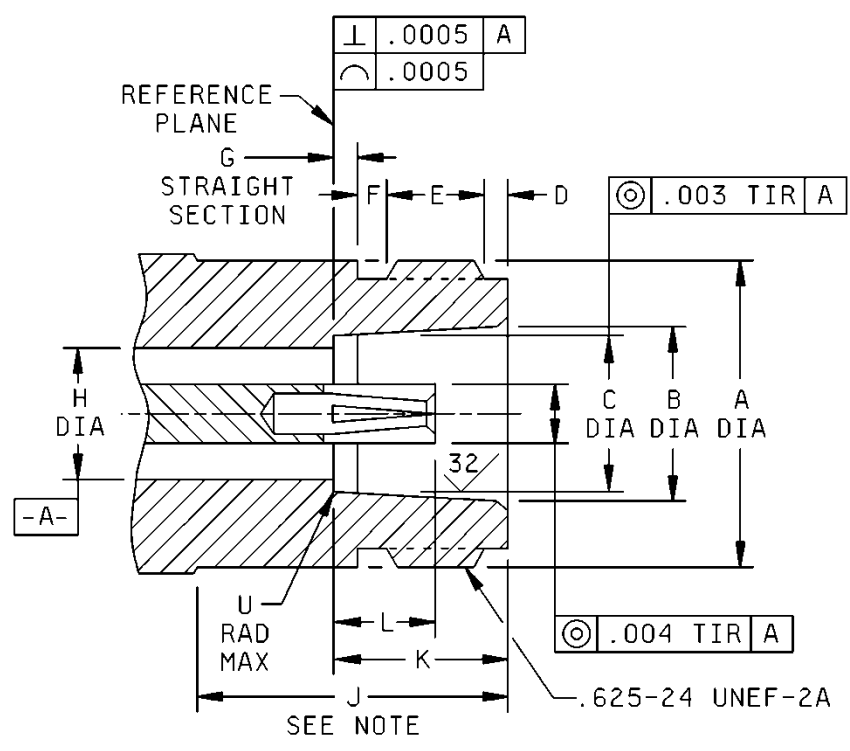

DETAIL OF INNER CONTACT

FIGURE 402-2. Interface, test connector, series N, socket contact.

MIL-STD-348B
 w/CHANGE 2

Dim Ltr	Inches (mm)	
	Minimum	Maximum
A	-----	.627 (15.93)
B	.336 (8.53)	.344 (8.74)
C	.317 (8.05)	.319 (8.10)
D	.047 (1.19)	.077 (1.96)
E	.180 (4.57)	.220 (5.59)
F	.040 (1.02)	.080 (2.03)
G	.020 (0.51)	.040 (1.02)
H	.2753 (6.991)	.2759 (7.008)
J	.442 (11.23)	-----
K	.357 (9.07)	.361 (9.17)
L	.204 (5.18)	.207 (5.26)
M	.1194 (3.033)	.1200 (3.048)
N	.370 (9.40)	-----
P	.1314 (3.327)	.1326 (3.368)
R	.0709 (1.801)	.0731 (1.857)
S	.240 (6.10)	.260 (6.60)
T	.000 (0.00)	.006 (0.15)
U	-----	.004 (0.10)
V	.003 (0.08)	.006 (0.15)
W	.1232 (3.129)	.1268 (3.221)
X	.0095 (0.241)	.0125 (0.317)

NOTE: Clearance for mating connector coupling nut.

FIGURE 402-2. Interface, test connector, series N, socket contact - Contined.

MIL-STD-348B
w/CHANGE 2

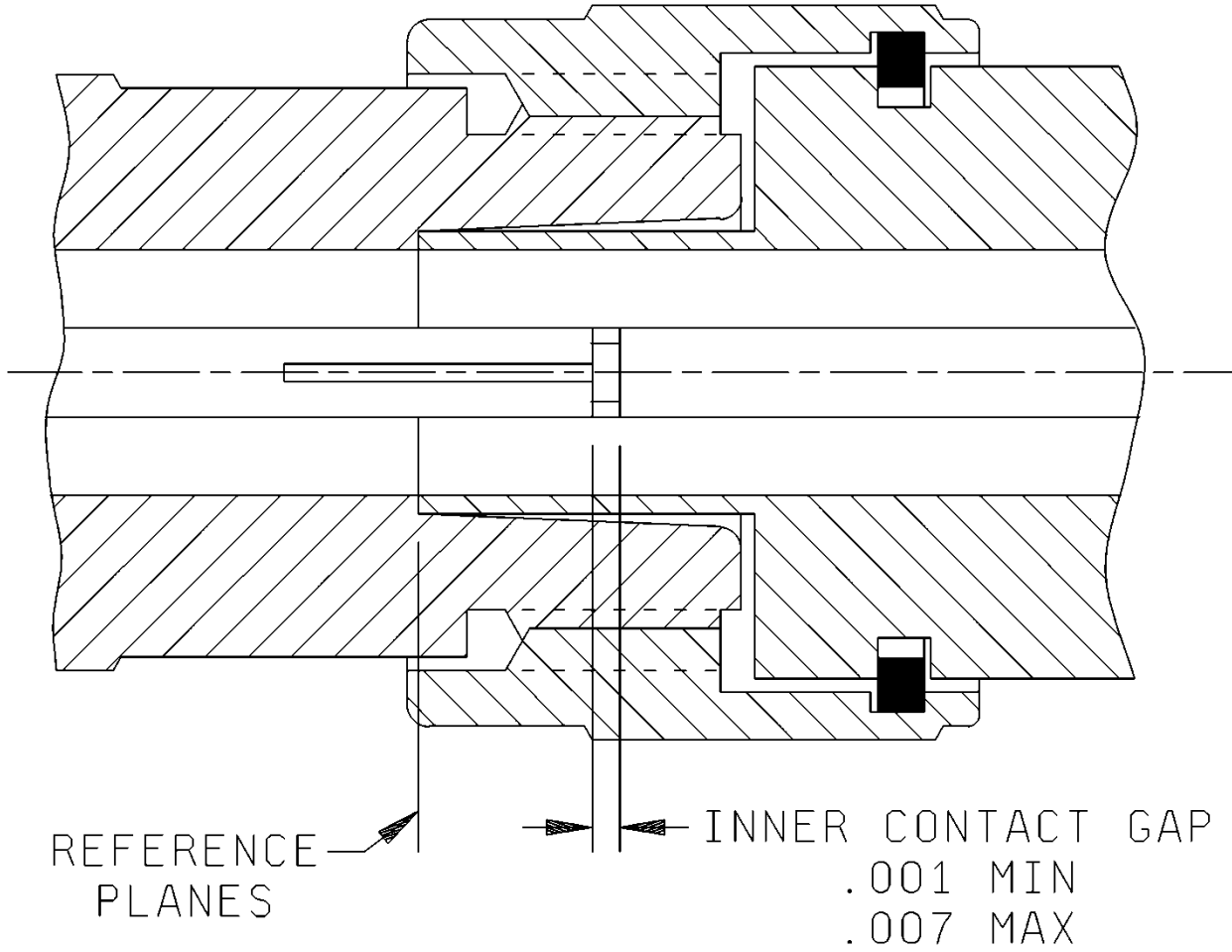

Inches (mm)
.001 (0.03)
.007 (0.18)

FIGURE 402-3. Interface, mated test connector, series N.

MIL-STD-348B
 w/CHANGE 2

Dim Ltr	Inches (mm)	
	Minimum	Maximum
A	.690 (17.53)	-----
B	.407 (10.34)	.409 (10.39)
C	.276 (7.01)	.280 (7.11)
D	.194 (4.93)	.198 (5.03)
E	.380 (9.65)	.420 (10.67)
F	.190 (4.83)	.210 (5.33)
G	.007 (0.18)	.013 (0.33)
H	.3889 (9.878)	.3897 (9.898)
J	.309 (7.85)	.318 (8.08)
K	.307 (7.80)	.311 (7.90)
L	-----	.085 (2.16)
M	.1192 (3.028)	.1202 (3.053)
N	.0900 (2.286)	.0921 (2.339)
P	.301 (7.65)	.308 (7.82)
R	.093 (2.36)	.103 (2.62)
T	.041 (1.04)	.051 (1.30)

FIGURE 403-1. Interface, test connector, series SC, pin contact - Continued.

MIL-STD-348B
 w/CHANGE 2

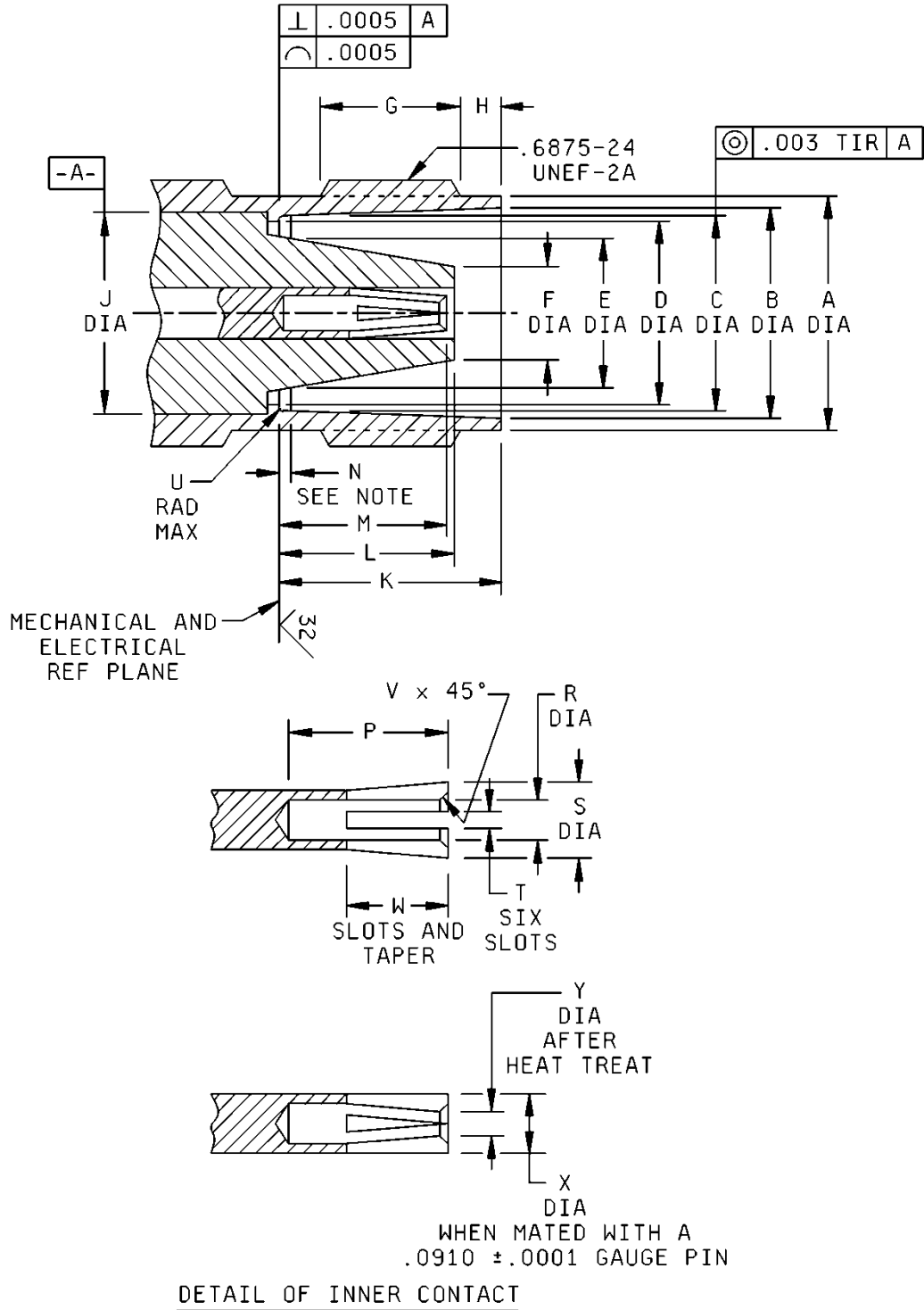

FIGURE 403-2. Interface, test connector, series SC, socket contact.

**MIL-STD-348B
 w/CHANGE 2**

Dim Ltr	Inches (mm)	
	Minimum	Maximum
A	-----	.630 (16.00)
B	.482 (12.24)	.498 (12.65)
C	.411 (10.44)	.415 (10.54)
D	.354 (8.99)	.358 (9.09)
E	.268 (6.81)	.272 (6.91)
F	.188 (4.78)	.190 (4.83)
G	.250 (6.35)	-----
H	.047 (1.19)	.077 (1.96)
J	.3889 (9.88)	.3897 (9.90)
K	.491 (12.47)	.495 (12.57)
L	.303 (7.70)	.309 (7.85)
M	.297 (7.54)	.305 (7.75)
N	.020 (0.51)	.040 (1.02)
P	.306 (7.77)	-----
R	.0969 (2.46)	.0991 (2.52)
S	.1314 (3.34)	.1326 (3.37)
T	.0095 (0.24)	.0125 (0.32)
U	-----	.004 (0.10)
V	.004 (0.10)	.011 (.28)
W	.240 (6.10)	.260 (6.60)
X	.1232 (3.129)	.1268 (3.221)
Y	.085 (2.16)	.088 (2.24)

NOTE. Applies to body straight section.

FIGURE 403-2. Interface, test connector, series SC, socket contact – Continued.

MIL-STD-348B
w/CHANGE 2

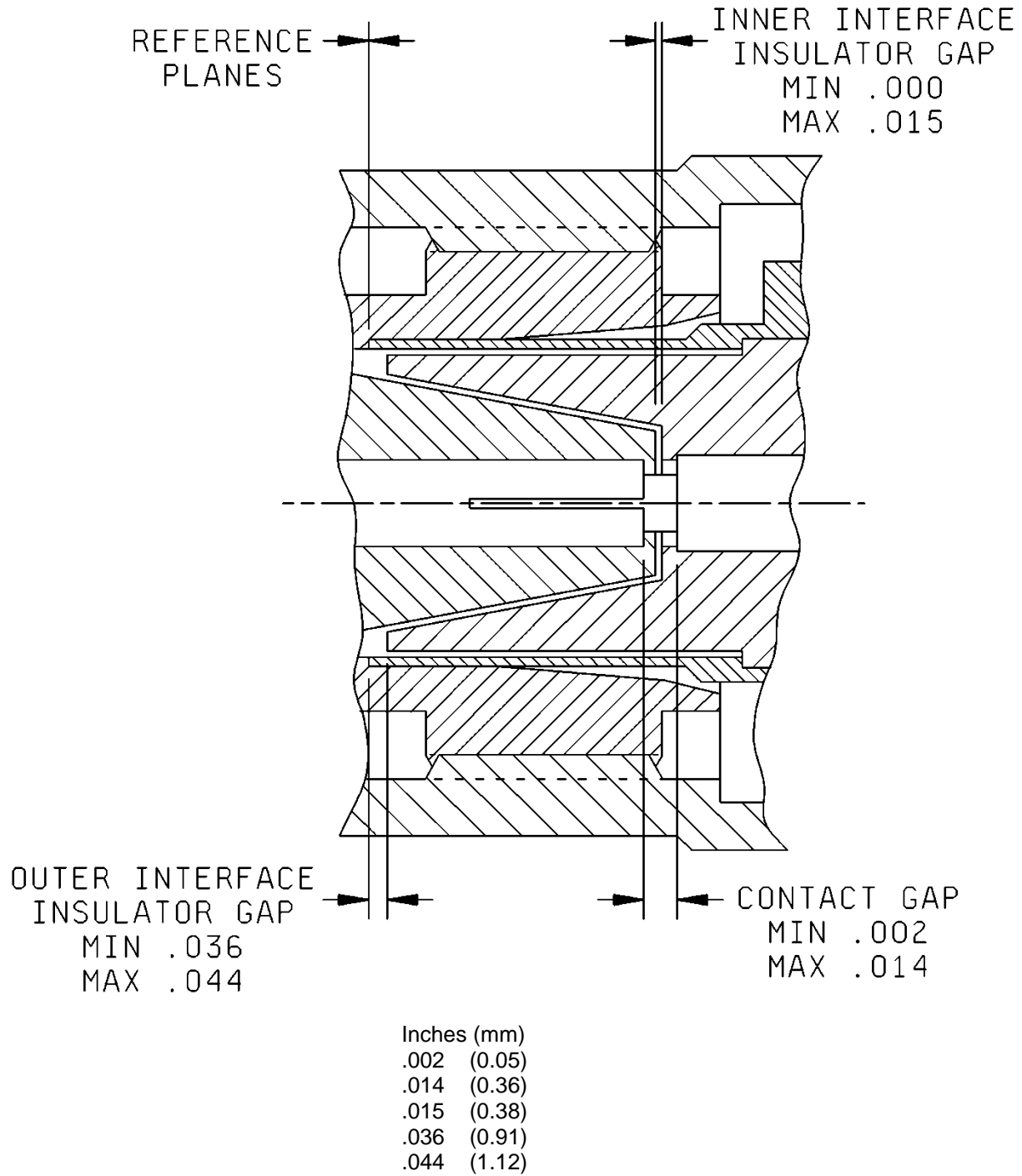

FIGURE 403-3. Interface, mated test connector, series SC.

MIL-STD-348B
 w/CHANGE 2

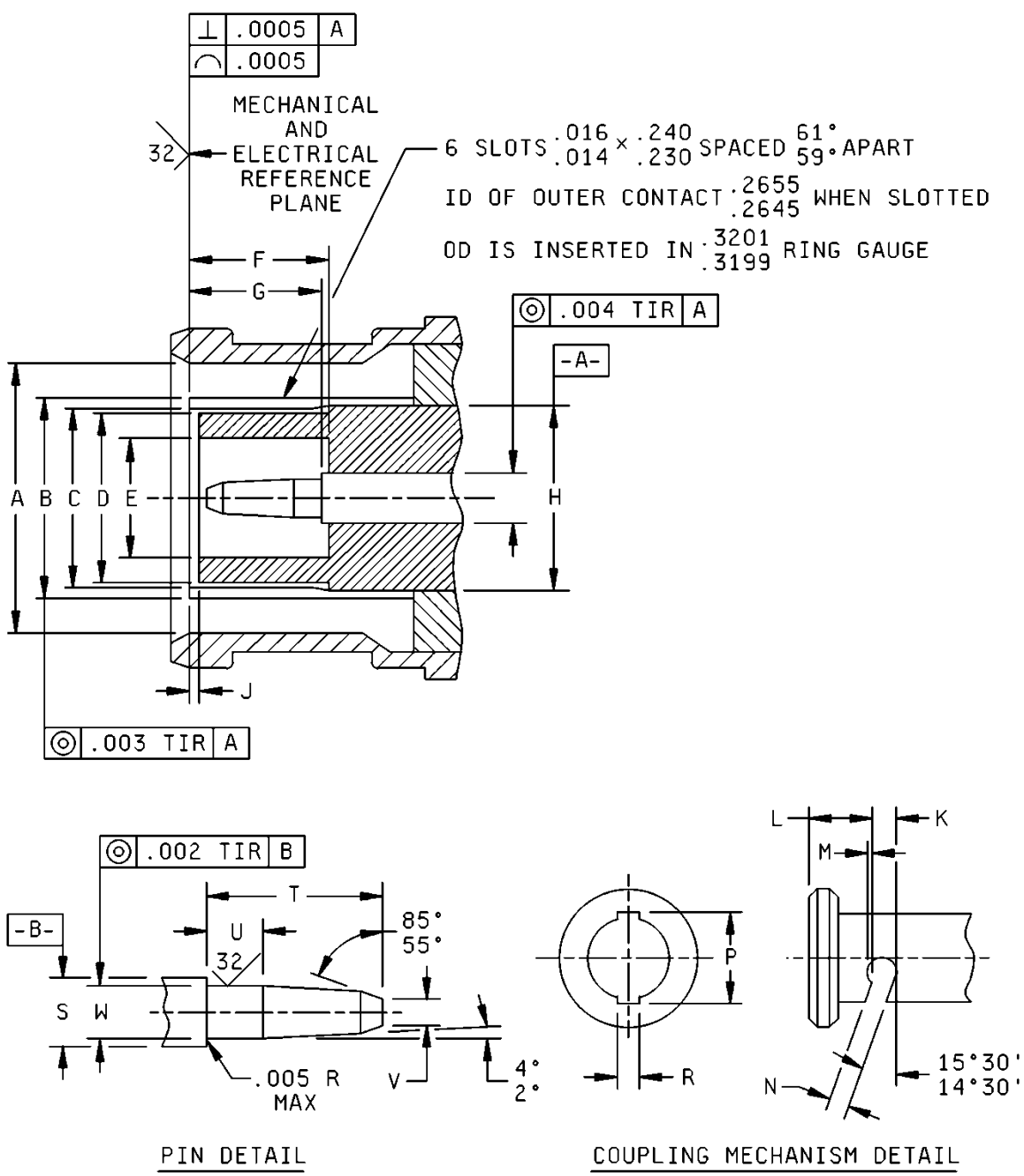

FIGURE 404-1. Interface, test connector, series BNC, pin contact.

MIL-STD-348B
 w/CHANGE 2

Dim Ltr	Inches (mm)	
	Minimum	Maximum
A	.385 (9.78)	.390 (9.91)
B	.312 (7.92)	.319 (8.10)
C	.2645 (6.718)	.2655 (6.744)
D	.260 (6.60)	.262 (6.65)
E	.192 (4.88)	.194 (4.93)
F	.212 (5.38)	.218 (5.54)
G	.209 (5.31)	.212 (5.38)
H	.2752 (6.990)	.2760 (7.010)
J	.006 (0.15)	.012 (0.30)
K	.124 (3.15)	-----
L	.180 (4.57)	.184 (4.67)
M	.018 (0.46)	.022 (0.56)
N	.091 (2.31)	.097 (2.46)
P	.463 (11.76)	.473 (12.01)
R	.091 (2.31)	.097 (2.46)
S	.0851 (2.161)	.0859 (2.182)
T	.182 (4.62)	.192 (4.88)
U	.055 (1.40)	.065 (1.65)
V	.013 (0.33)	.027 (0.69)
W	.0530 (1.346)	.0541 (1.374)

FIGURE 404-1. Interface, test connector, series BNC, pin contact – Continued.

MIL-STD-348B
 w/CHANGE 2

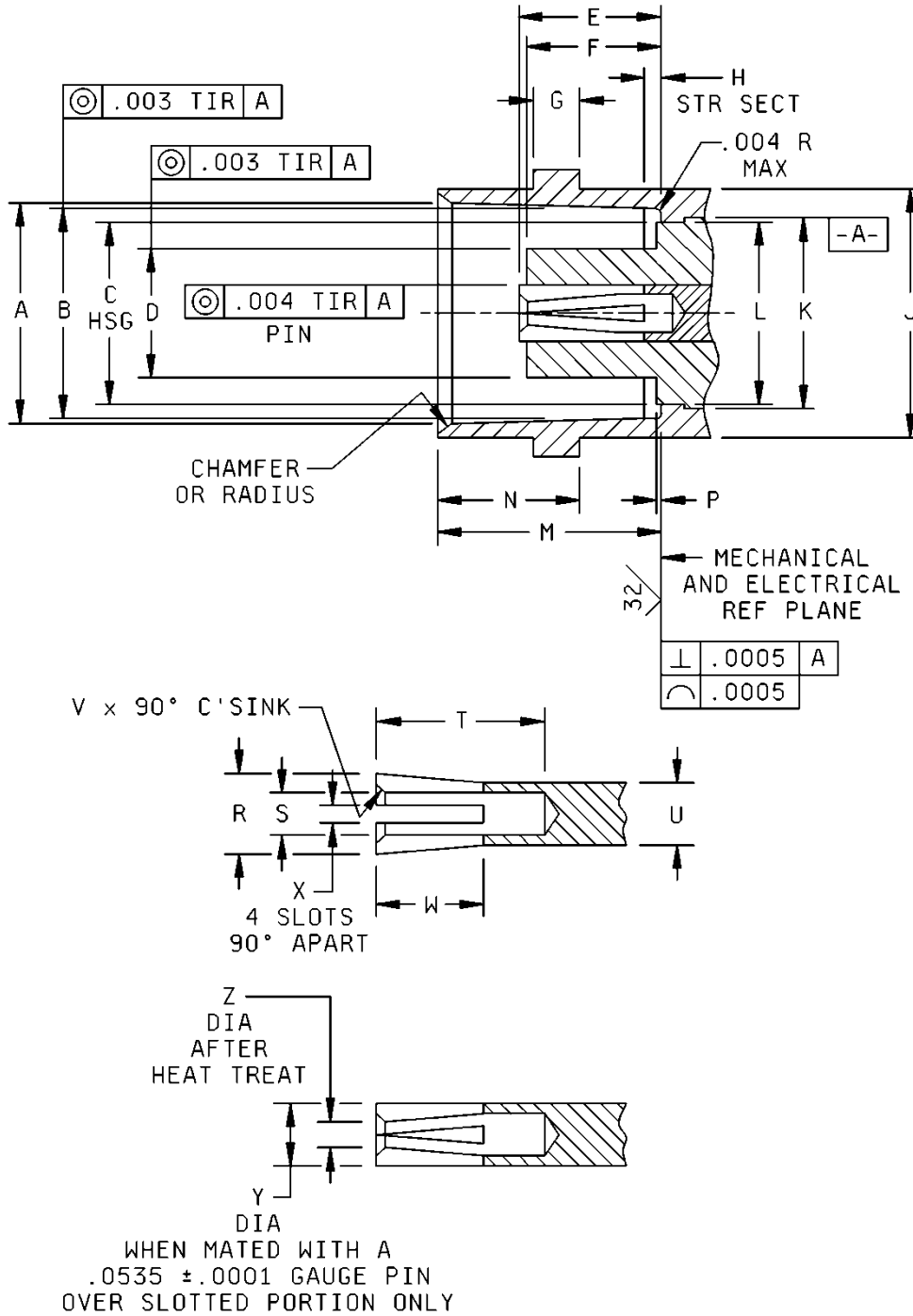

DETAIL OF INNER CONTACT

FIGURE 404-2. Interface, test connector, series BNC, socket contact.

MIL-STD-348B
 w/CHANGE 2

Dim Ltr	Inches (mm)	
	Minimum	Maximum
A	.327 (8.31)	.333 (8.46)
B	.319 (8.10)	.321 (8.15)
C	.264 (6.71)	.266 (6.76)
D	.184 (4.67)	.186 (4.72)
E	.205 (5.21)	.208 (5.28)
F	.200 (5.08)	.206 (5.23)
G	.075 (1.91)	.081 (2.06)
H	.020 (0.51)	.040 (1.02)
J	.378 (9.60)	.381 (9.68)
K	.2752 (6.990)	.2760 (7.010)
L	-----	.256 (6.50)
M	.329 (8.36)	.333 (8.46)
N	.204 (5.18)	.208 (5.28)
P	.000 (0.00)	.008 (0.20)
R	.0965 (2.451)	.0976 (2.479)
S	.0600 (1.524)	.0622 (1.580)
T	.205 (5.21)	-----
U	.0852 (2.164)	.0859 (2.182)
V	.066 (1.68)	.074 (1.88)
W	.182 (4.62)	.192 (4.88)
X	.0105 (0.267)	.0135 (0.343)
Y	.0878 (2.230)	.0911 (2.314)
Z	.0475 (1.206)	.0510 (1.295)

FIGURE 404-2. Interface, test connector, series BNC, socket contact - Continued.

MIL-STD-348B
w/CHANGE 2

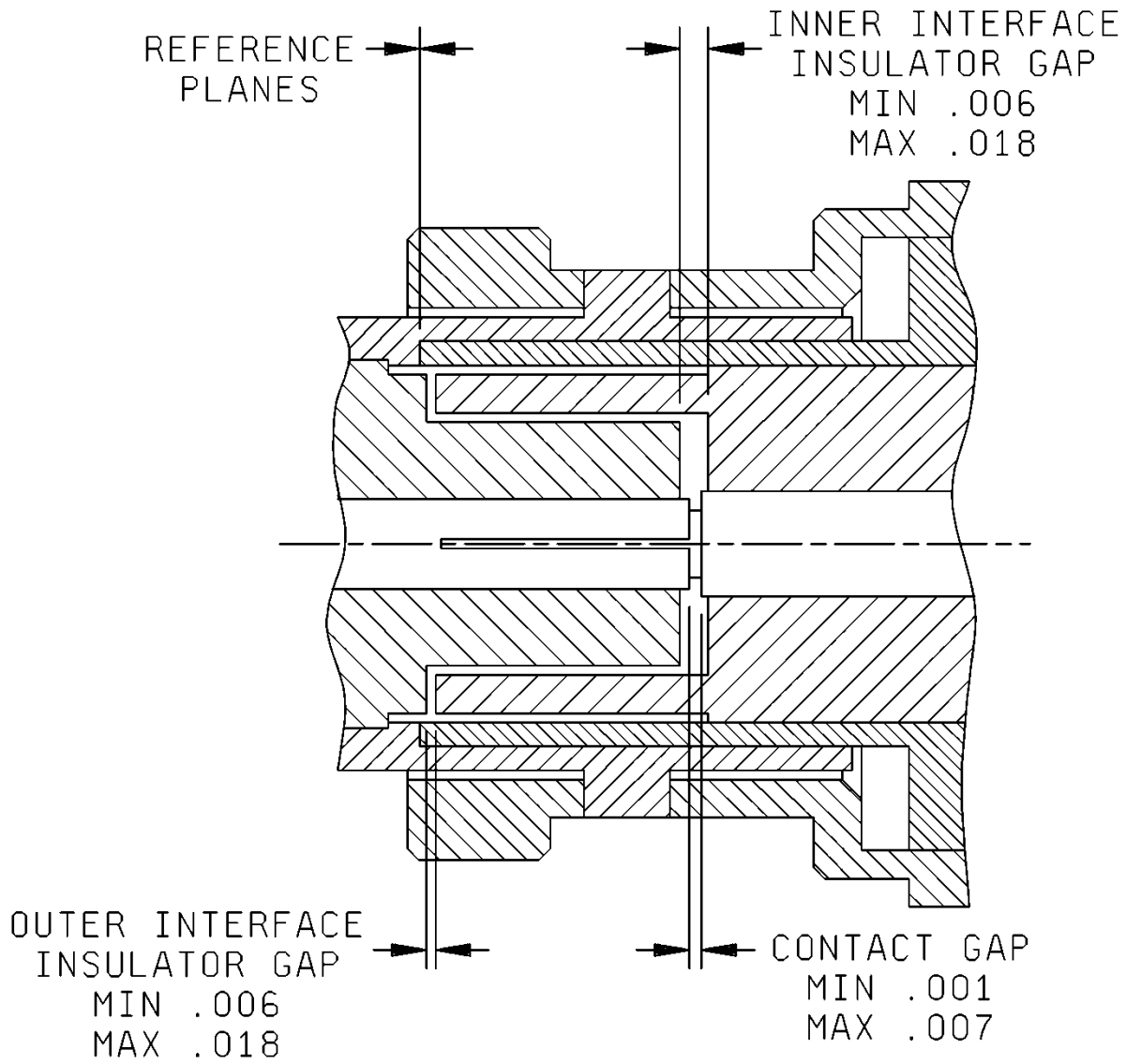

Inches (mm)	
.001	(0.03)
.006	(0.15)
.007	(0.18)
.018	(0.46)

FIGURE 404-3. Interface, mated test connector, series BNC.

MIL-STD-348B
 w/CHANGE 2

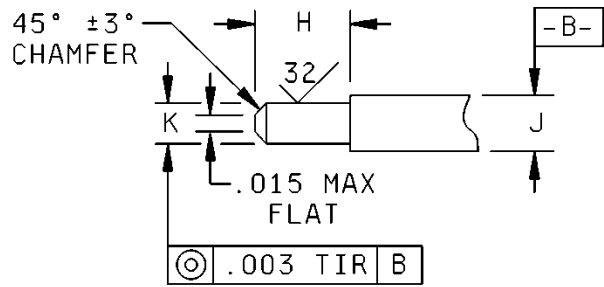
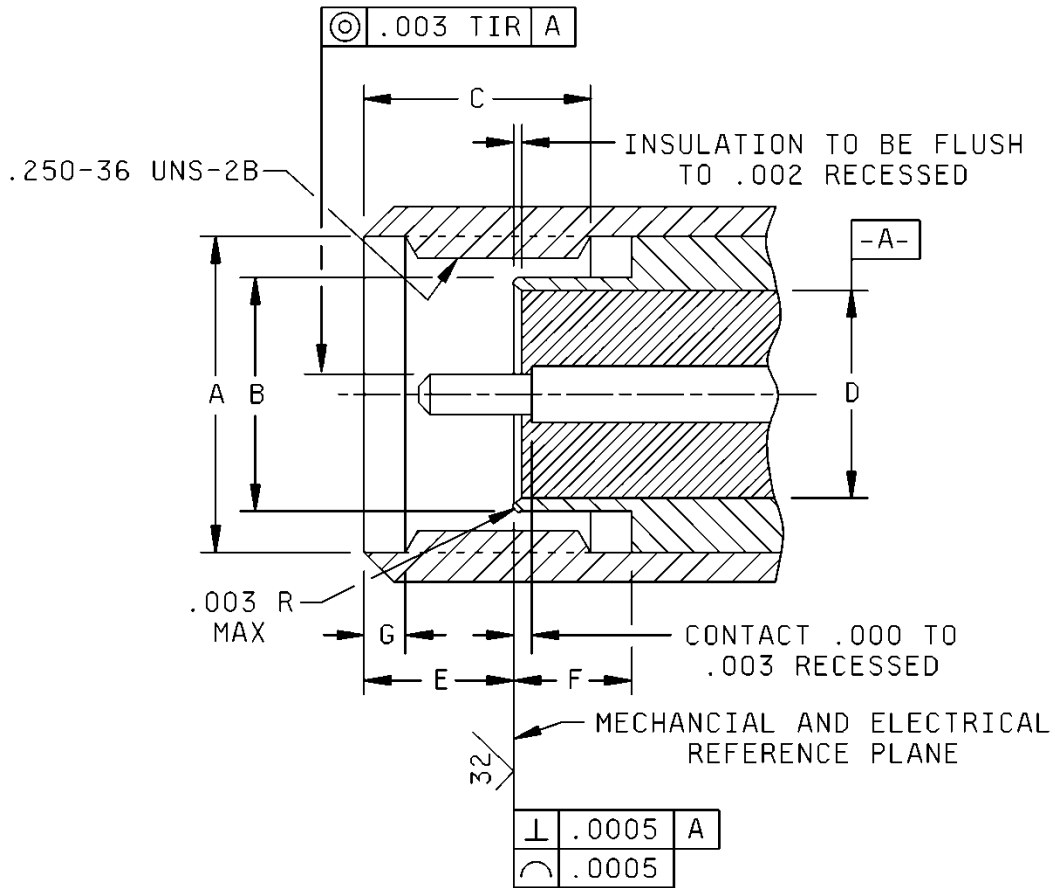

DETAIL OF INNER CONTACT

FIGURE 405-1. Interface, test connector, series SMA, pin contact.

MIL-STD-348B
 w/CHANGE 2

Dim Ltr	Inches (mm)	
	Minimum	Maximum
A DIA	.255 (6.48)	.265 (6.73)
B DIA	.1780 (4.521)	.1808 (4.592)
C	.146 (3.71)	.170 (4.32)
D DIA	.1615 (4.102)	.1625 (4.127)
E	.102 (2.59)	.132 (3.35)
F	.080 (2.03)	-----
G	.025 (0.64)	.045 (1.14)
H	.080 (2.03)	.090 (2.29)
J DIA	.0500 (1.270)	.0506 (1.285)
K DIA	.0355 (0.902)	.0365 (0.927)

FIGURE 405-1. Interface, test connector, series SMA, pin contact – Continued.

MIL-STD-348B
 w/CHANGE 2

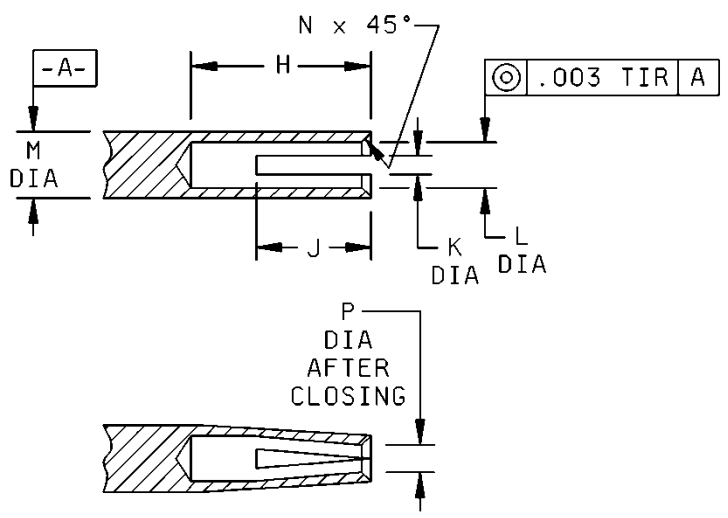
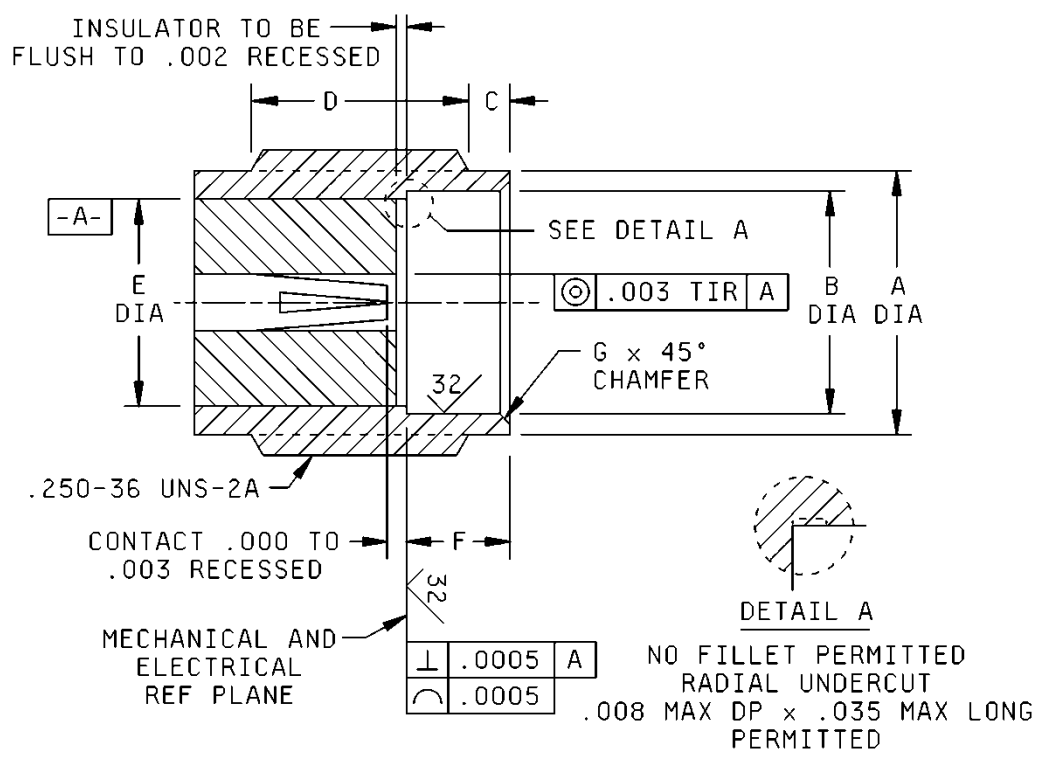

DETAIL OF INNER CONTACT

FIGURE 405-2. Interface, test connector, series SMA, socket contact.

MIL-STD-348B
 w/CHANGE 2

Dim Ltr	Inches (mm)	
	Minimum	Maximum
A	.208 (5.28)	.216 (5.49)
B	.1810 (4.597)	.1837 (4.666)
C	.015 (.38)	.045 (1.14)
D	.150 (3.81)	-----
E	.1615 (4.102)	.1625 (4.127)
F	.074 (1.88)	.078 (1.98)
G	-----	.010 (0.25)
H	.100 (2.54)	-----
J	.075 (1.91)	.095 (2.41)
K	.005 (0.13)	.009 (0.23)
L	.0370 (0.940)	.0390 (0.991)
M	.0500 (1.270)	.0506 (1.285)
N	.039 (0.99)	.047 (1.19)
P	.0285 (0.724)	.0330 (0.838)

FIGURE 405-2. Interface, test connector, series SMA, socket contact – Continued.

MIL-STD-348B
w/CHANGE 2

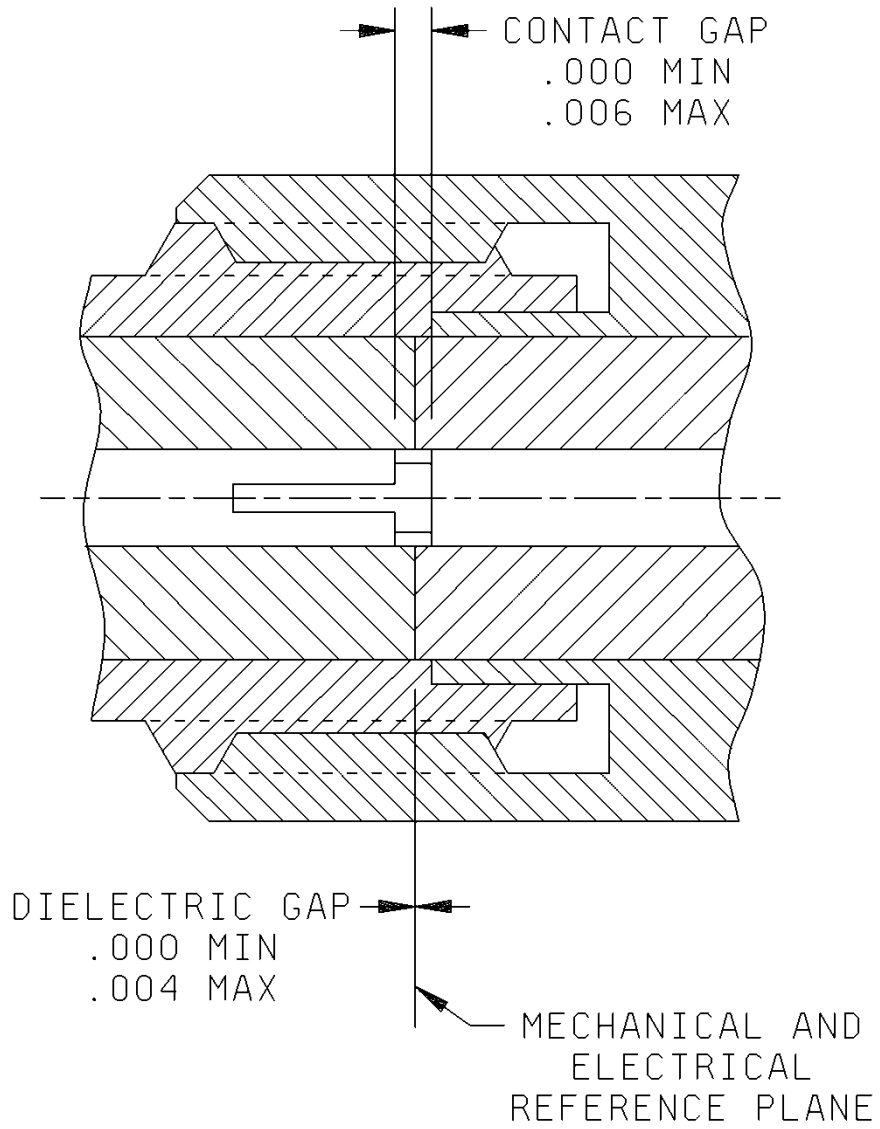

Inches (mm)
.004 (0.10)
.006 (0.15)

FIGURE 405-3. Interface, mated test connector, series SMA.

MIL-STD-348B
 w/CHANGE 2

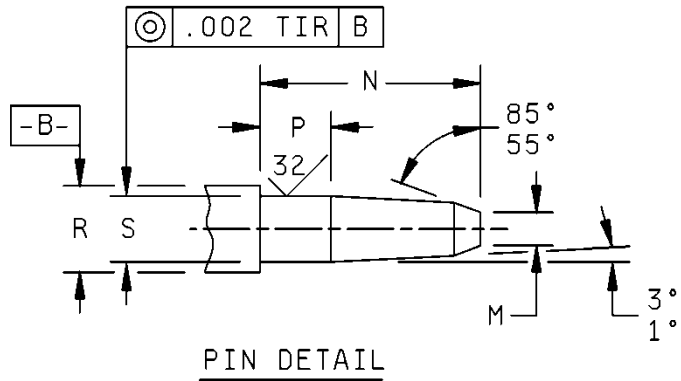
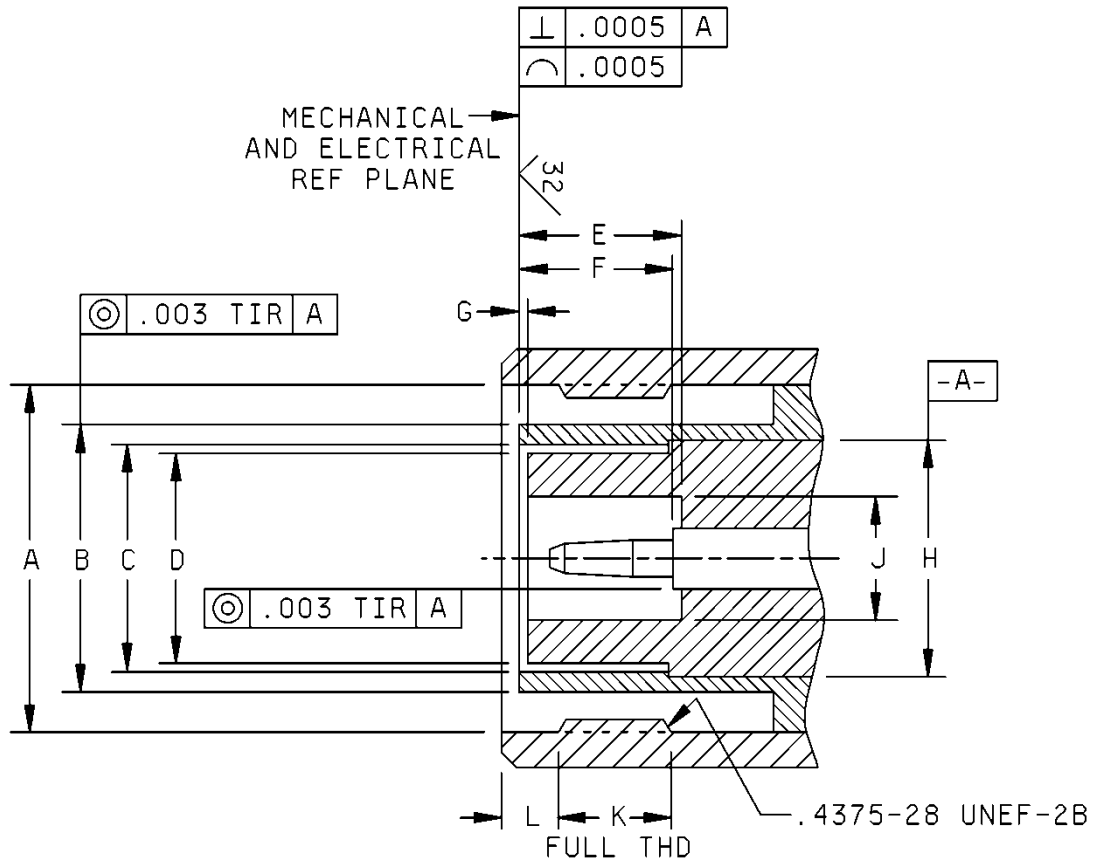

FIGURE 406-1. Interface, test connector, series TNC, pin contact.

MIL-STD-348B
 w/CHANGE 2

Dim Ltr	Inches (mm)	
	Minimum	Maximum
A	.440 (11.18)	-----
B	.3175 (8.064)	.3185 (8.090)
C	.2645 (6.718)	.2655 (6.744)
D	.260 (6.60)	.262 (6.65)
E	.212 (5.38)	.218 (5.54)
F	.209 (5.31)	.212 (5.38)
G	.006 (0.15)	.012 (0.30)
H	.2752 (6.990)	.2760 (7.010)
J	.192 (4.88)	.194 (4.93)
K	.156 (3.96)	-----
L	.063 (1.60)	-----
M	.013 (0.33)	.027 (0.69)
N	.182 (4.62)	.192 (4.88)
P	.055 (1.40)	.065 (1.65)
R	.0851 (2.161)	.0859 (2.182)
S	.0530 (1.346)	.0541 (1.374)

FIGURE 406-1. Interface, test connector, series TNC, pin contact - Continued.

MIL-STD-348B
 w/CHANGE 2

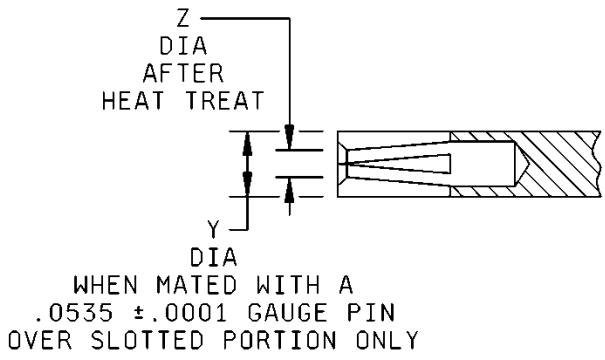
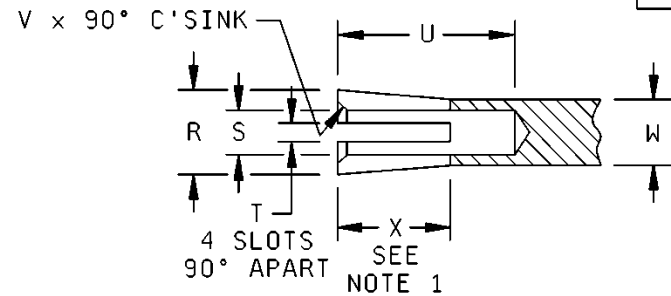
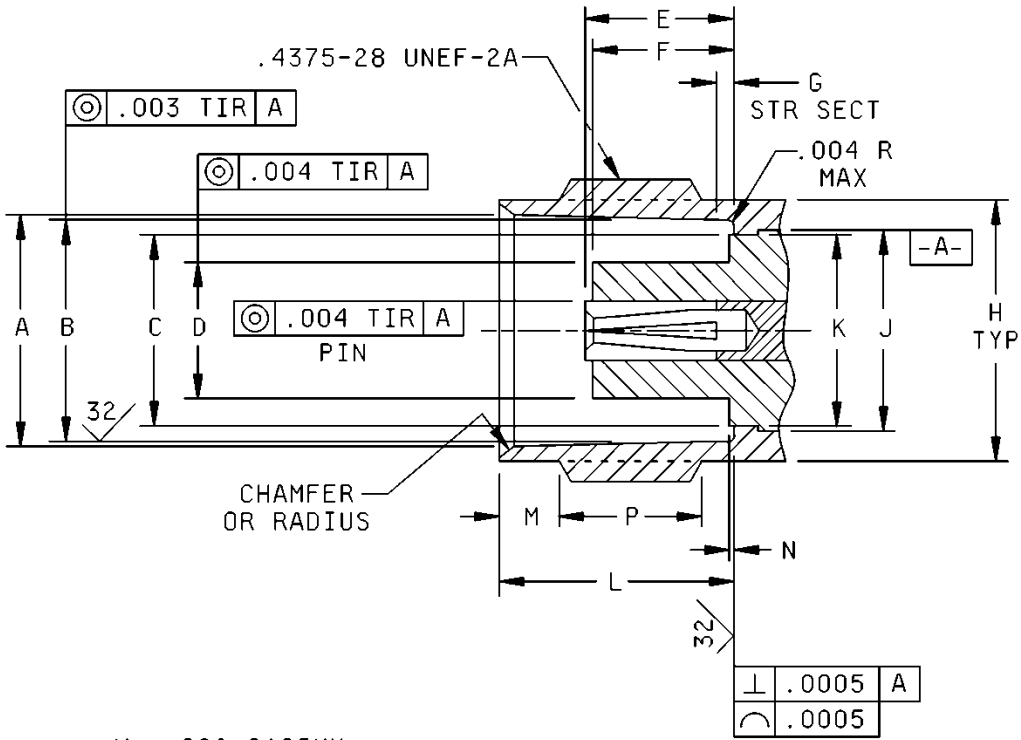

DETAIL OF INNER CONTACT

FIGURE 406-2. Interface, test connector, series TNC, socket contact.

MIL-STD-348B
 w/CHANGE 2

Dim Ltr	Inches (mm)	
	Minimum	Maximum
A	.327 (8.31)	.333 (8.46)
B	.319 (8.10)	.321 (8.15)
C	.000 (0.00)	.256 (6.50)
D	.184 (4.67)	.186 (4.72)
E	.205 (5.21)	.208 (5.28)
F	.200 (5.08)	.208 (5.28)
G	.020 (0.51)	.040 (1.02)
H	.378 (9.60)	.381 (9.68)
J	.2752 (6.99)	.2760 (7.01)
K	.264 (6.71)	.266 (6.76)
L	.329 (8.36)	.333 (8.46)
M	.068 (1.73)	.088 (2.24)
N	.000 (0.00)	.006 (0.15)
P	.187 (4.75)	-----
R	.0965 (2.45)	.0978 (2.48)
S	.0600 (1.52)	.0622 (1.58)
T	.0105 (0.27)	.0135 (0.34)
U	.205 (5.21)	-----
V	.066 (1.68)	.074 (1.88)
W	.0852 (2.16)	.0859 (2.18)
X	.182 (4.62)	.192 (4.88)
Y	.0878 (2.23)	.0911 (2.31)
Z	.0475 (1.21)	.0510 (1.30)

NOTES:

1. Contact to be slotted to meet mechanical and electrical performance in specification.
2. Dimension C and N to apply to dielectric projection.

FIGURE 406-2. Interface, test connector, series TNC, socket contact – Continued.

MIL-STD-348B
w/CHANGE 2

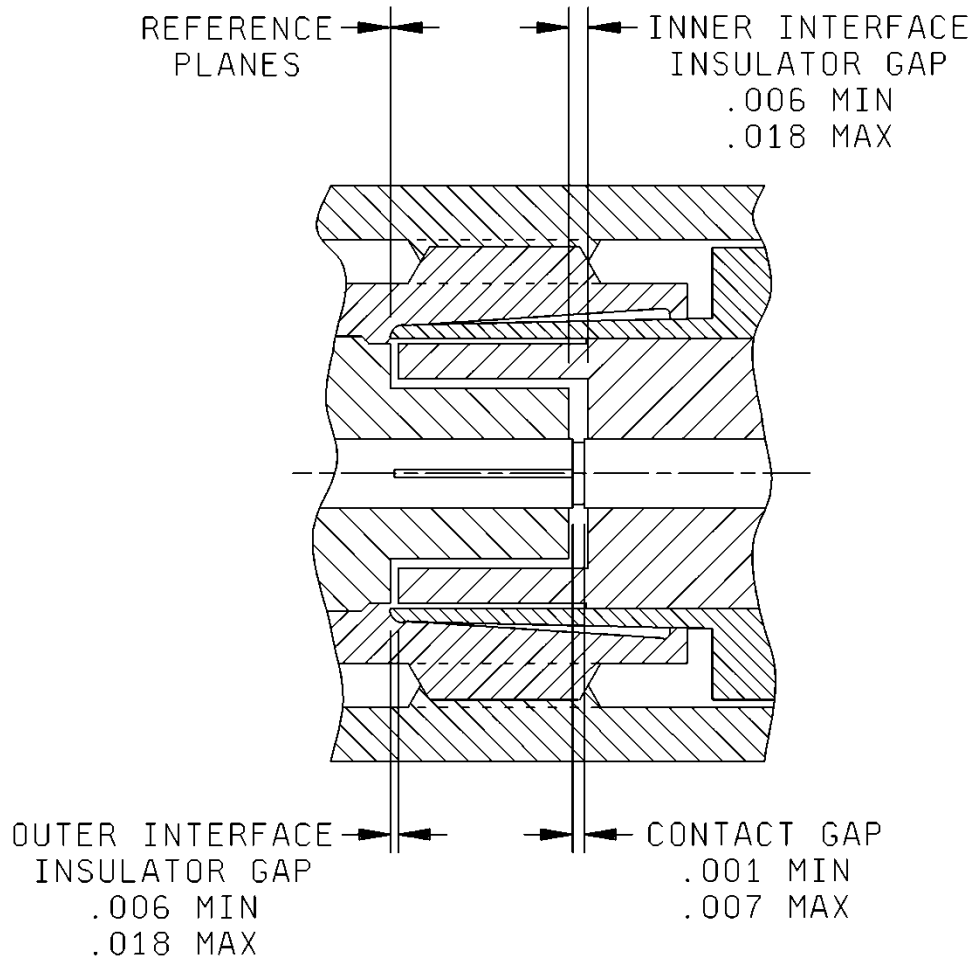

Inches (mm)	
.001	(0.03)
.006	(0.15)
.007	(0.18)
.018	(0.46)

FIGURE 406-3. Interface, mated test connector, series TNC.

MIL-STD-348B
 w/CHANGE 2

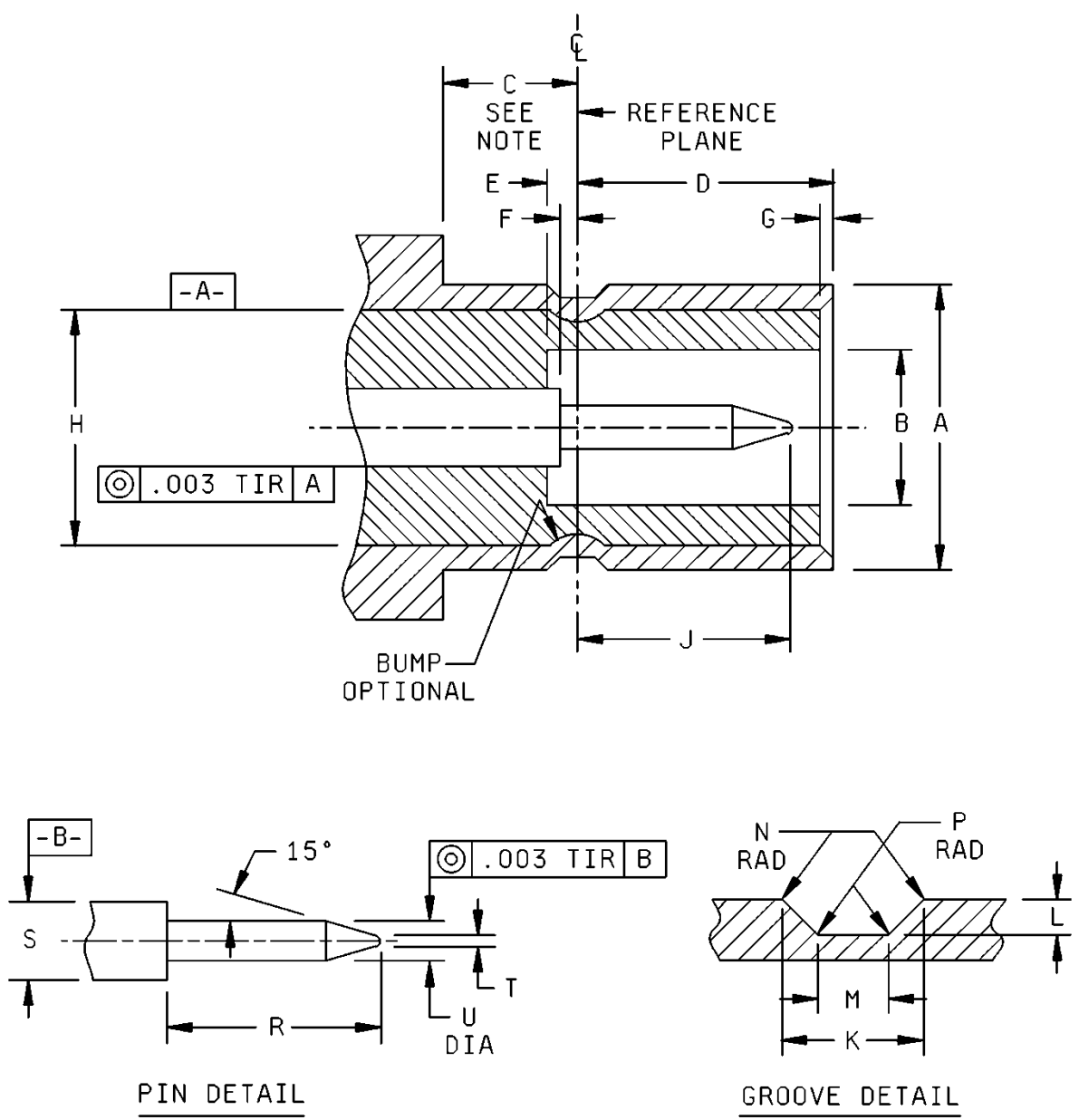

FIGURE 407-1. Interface, test connector, series SMB, pin contact.

MIL-STD-348B
 w/CHANGE 2

Dim Ltr	Inches (mm)	
	Minimum	Maximum
A	.144 (3.66)	.146 (3.71)
B	.082 (2.08)	.085 (2.16)
C	.065 (1.65)	-----
D	.137 (3.48)	.139 (3.53)
E	.0045 (0.11)	.0095 (0.24)
F	.0035 (0.09)	.0045 (0.11)
G	.0015 (0.038)	.0095 (0.241)
H	.120 (3.05)	.121 (3.07)
J	.094 (2.39)	.107 (2.72)
K	.027 (0.69)	.037 (0.94)
L	.006 (0.15)	.010 (0.25)
M	.011 (0.28)	.015 (0.38)
N	.002 (0.05)	.006 (0.15)
P	-----	.005 (0.13)
R	.099 (2.51)	.103 (2.62)
S	.0381 (0.968)	.0389 (0.988)
T	-----	.010 (0.25)
U	.019 (0.48)	.021 (0.53)

NOTE: Clearance for mating coupling nut.

FIGURE 407-1. Interface, test connector, series SMB, pin contact - Continued.

MIL-STD-348B
 w/CHANGE 2

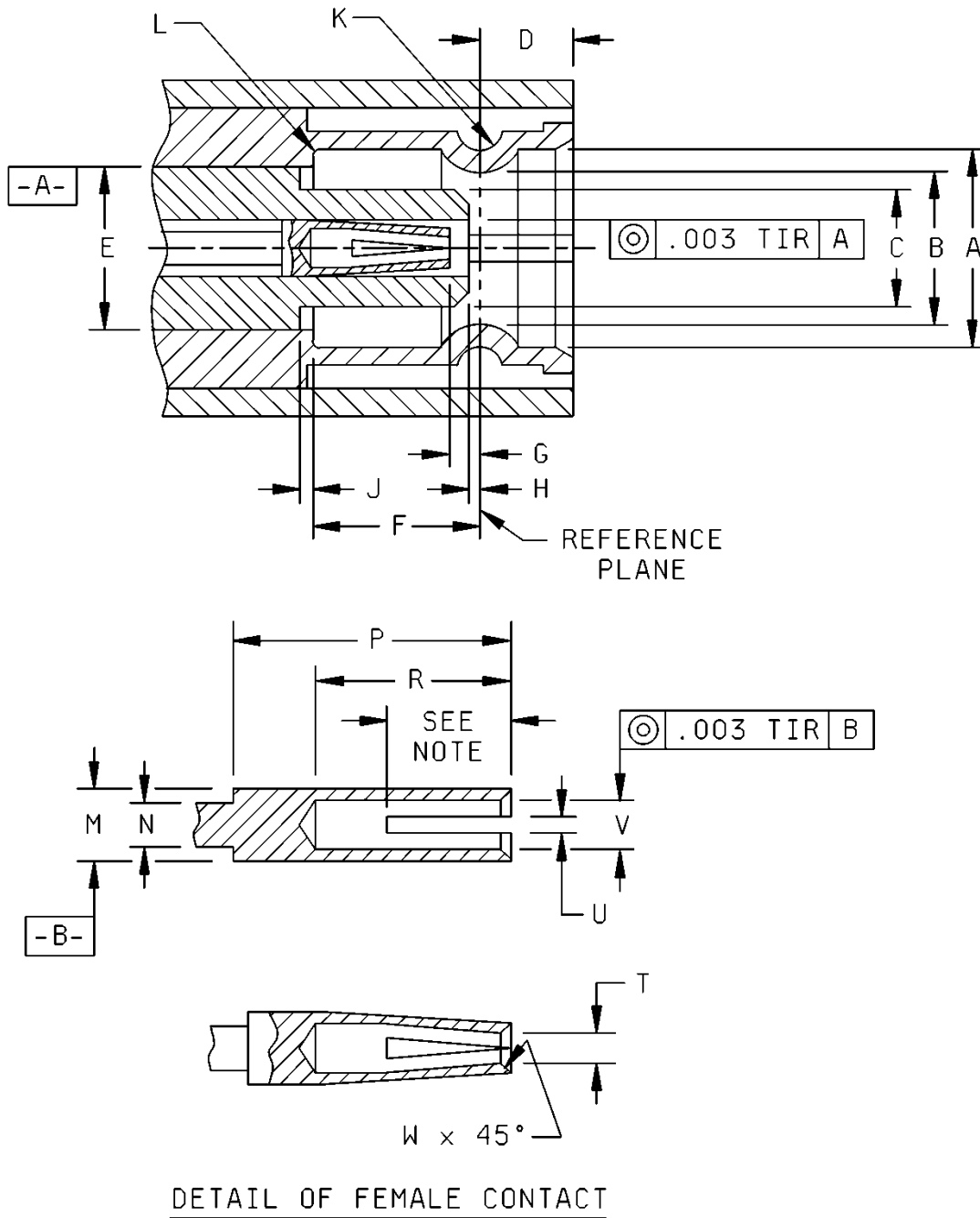

FIGURE 407-2. Interface, test connector, series SMB, socket contact.

**MIL-STD-348B
 w/CHANGE 2**

Dim Ltr	Inches (mm)	
	Minimum	Maximum
A	.147 (3.73)	.149 (3.78)
B	.134 (3.40)	.136 (3.45)
C	.079 (2.01)	.081 (2.06)
D	-----	.064 (1.63)
E	.120 (3.05)	.121 (3.07)
F	.141 (3.58)	.149 (3.78)
G	.0115 (0.292)	.0225 (0.571)
H	.0105 (0.267)	.0205 (0.521)
J	-.0005 (0.018)	+.0115 (0.292)
K RAD	.025 (0.64)	.030 (0.76)
L RAD	-----	.003 (0.08)
M	.0396 (1.006)	.0404 (1.026)
N	.0381 (0.968)	.0389 (0.988)
P	.1325 (3.365)	.1375 (3.492)
R	.110 (2.79)	-----
T	.0155 (0.39)	.0190 (0.483)
U	.005 (.013)	.009 (0.23)
V	.0219 (0.556)	.0236 (0.599)
W	.002 (0.05)	.006 (0.15)

NOTE. Contact to be slotted to meet mechanical and electrical performance requirements on specification.

FIGURE 407-2. Interface, test connector, series SMB, socket contact – Continued.

MIL-STD-348B
w/CHANGE 2

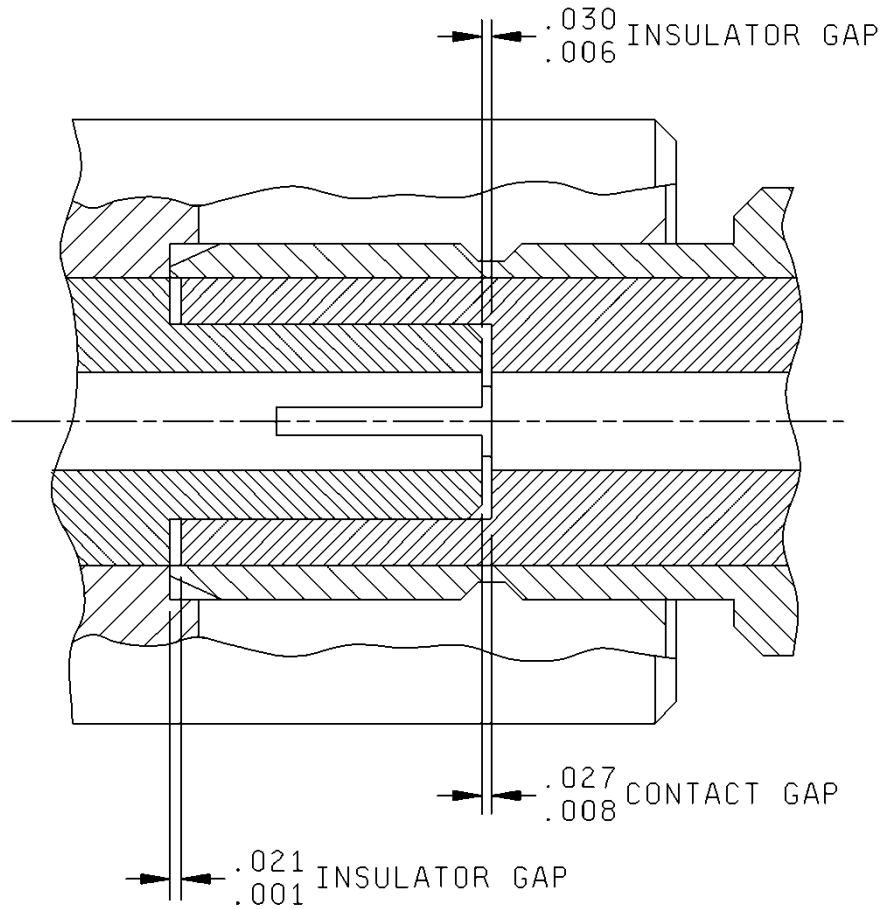

Inches (mm)	
.001	(0.03)
.006	(0.15)
.008	(0.20)
.021	(0.53)
.027	(0.69)
.030	(0.76)

FIGURE 407-3. Interface, mated test connector, series SMB.

MIL-STD-348B
 w/CHANGE 2

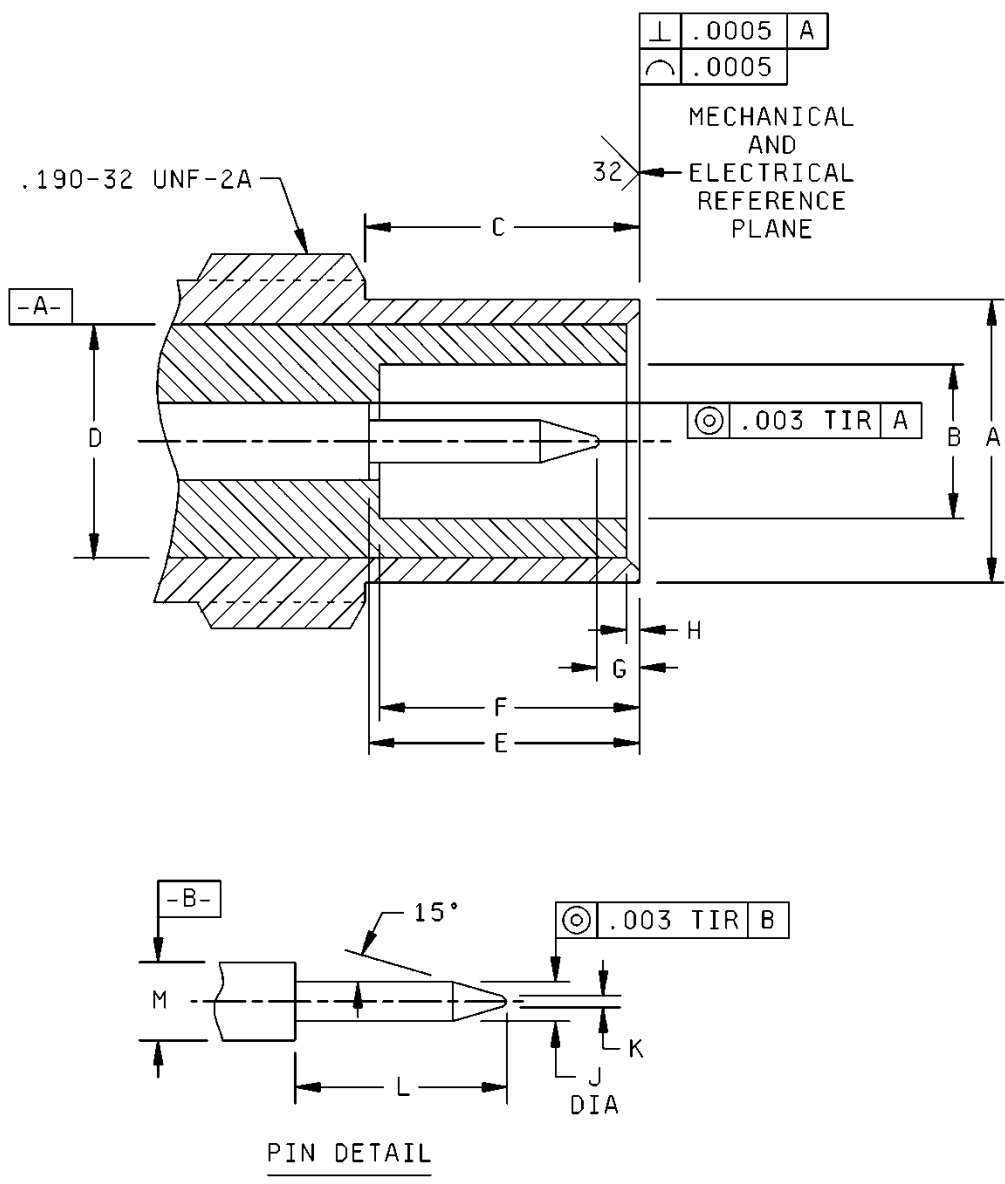

FIGURE 408-1. Interface, test connector, series SMC, pin contact.

MIL-STD-348B
 w/CHANGE 2

Dim Ltr	Inches (mm)	
	Minimum	Maximum
A	.144 (3.66)	.146 (3.71)
B	.082 (2.08)	.085 (2.16)
C	.123 (3.12)	.133 (3.38)
D	.120 (3.05)	.121 (3.07)
E	.134 (3.40)	.138 (3.51)
F	.134 (3.40)	.142 (3.61)
G	.031 (0.79)	-----
H	.000 (0.00)	.005 (0.13)
J	.019 (0.48)	.021 (0.53)
K	-----	.010 (0.25)
L	.099 (2.51)	.103 (2.62)
M	.0381 (0.968)	.0389 (0.988)

FIGURE 408-1. Interface, test connector, series SMC, pin contact - Continued.

MIL-STD-348B
 w/CHANGE 2

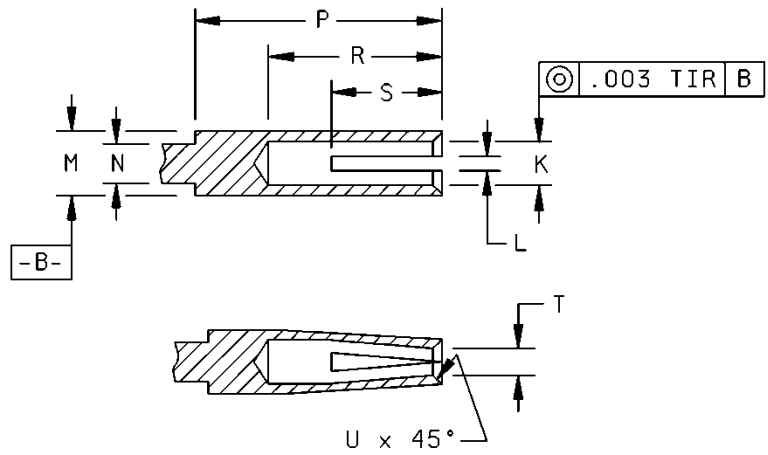
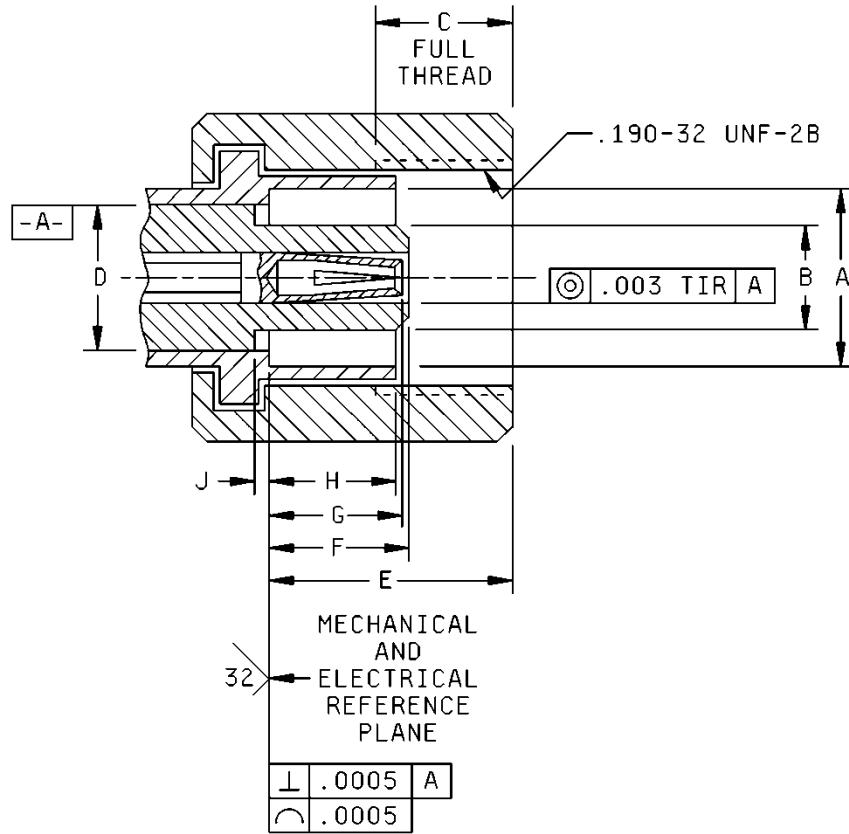

DETAIL OF FEMALE CONTACT

FIGURE 408-2. Interface, test connector, series SMC, socket contact.

MIL-STD-348B
 w/CHANGE 2

Dim Ltr	Inches (mm)	
	Minimum	Maximum
A	.147 (3.73)	.150 (3.81)
B	.079 (2.01)	.081 (2.06)
C	.110 (2.79)	-----
D	.120 (3.05)	.121 (3.07)
E	-----	.233 (5.92)
F	.130 (3.30)	.134 (3.40)
G	.127 (3.23)	.134 (3.40)
H	.120 (3.05)	.122 (3.10)
J	.000 (0.00)	.006 (0.15)
K	.0219 (0.556)	.0236 (0.599)
L	.005 (0.13)	.009 (0.23)
M	.0396 (1.006)	.0404 (1.026)
N	.0381 (0.968)	.0389 (0.998)
P	.1325 (3.365)	.1375 (3.492)
R	.110 (2.79)	-----
S	.065 (1.65)	
T	.0155 (0.394)	.0190 (0.483)
U	.002 (0.05)	.006 (0.15)

FIGURE 408-2. Interface, test connector, series SMC, socket contact - Continued.

MIL-STD-348B
w/CHANGE 2

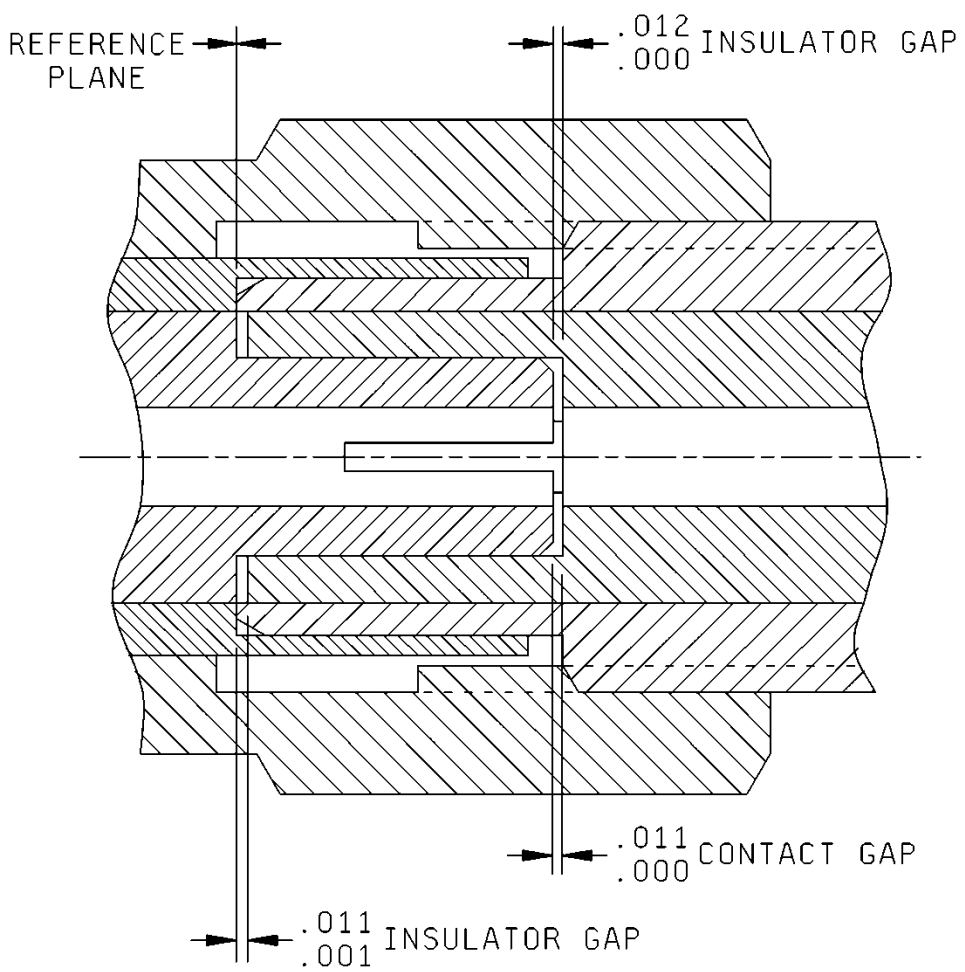

Inches (mm)	
.001	(0.03)
.011	(0.28)
.012	(0.30)

FIGURE 408-3. Interface, mated test connector, series SMC.

MIL-STD-348B
 w/CHANGE 2

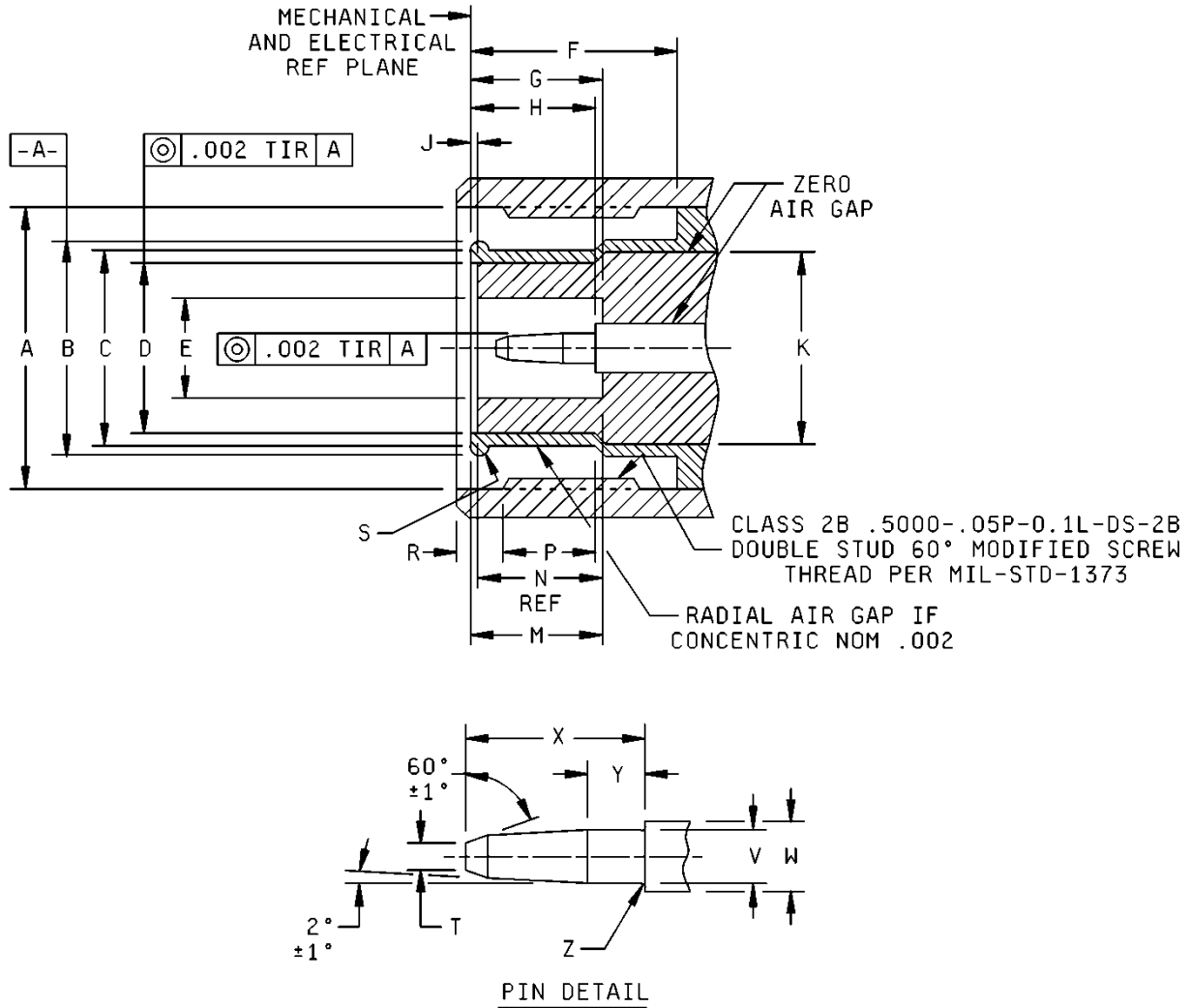

FIGURE 409-1. Interface, test connector, series QNC, pin contact.

MIL-STD-348B
 w/CHANGE 2

Dim Ltr	Inches (mm)	
	Minimum	Maximum
A	.516 (13.11)	.519 (13.18)
B	.319 (8.10)	.321 (8.15)
C	.2645 (6.718)	.2655 (6.744)
D	.260 (6.60)	.262 (6.65)
E	.190 (4.83)	-----
F	.340 (8.64)	-----
G	.212 (5.38)	.218 (5.54)
H	.209 (5.31)	.212 (5.38)
J	.006 (0.15)	.012 (0.30)
K	.2751 (6.987)	.2761 (7.013)
M	.209 (5.31)	.211 (5.36)
N	.203 (5.16) Reference	
P	.271 (6.88)	.291 (7.39)
R	.088 (2.24)	.098 (2.49)
S	.029 (0.74)	.035 (0.89)
T	.013 (0.33)	.027 (0.69)
V	.0530 (1.346)	.0540 (1.372)
W	.0837 (2.126)	.0847 (2.151)
X	.182 (4.62)	.192 (4.88)
Y	.035 (0.89)	.045 (1.14)
Z	-----	.005 (0.13) Rad

FIGURE 409-1. Interface, test connector, series QNC, pin contact - Continued.

MIL-STD-348B
 w/CHANGE 2

CLASS 2A .5000-0.05-0.1L-DS-2A
 DOUBLE STUD 60° MODIFIED
 SCREW THREADS PER MIL-STD-1373

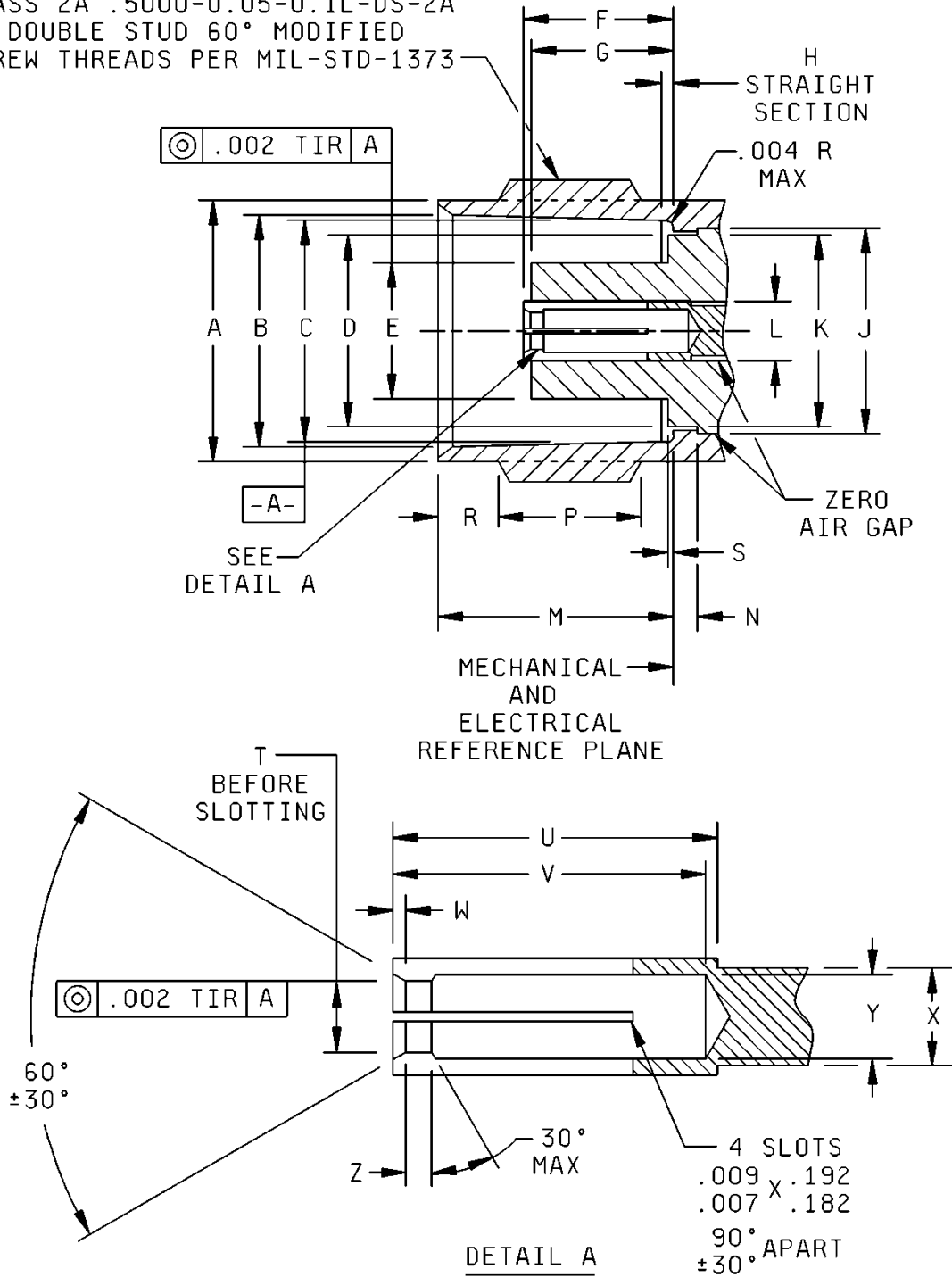

FIGURE 409-2. Interface, test connector, series QNC, socket contact.

MIL-STD-348B
 w/CHANGE 2

Dim Ltr	Inches (mm)	
	Minimum	Maximum
A	.446 (11.33)	.449 (11.40)
B	.327 (8.31)	.333 (8.46)
C	.319 (8.10)	.321 (8.15)
D	.264 (6.71)	.266 (6.76)
E	.184 (4.67)	.186 (4.72)
F	.205 (5.21)	.208 (5.28)
G	.200 (5.08)	.206 (5.23)
H	.026 (0.66)	.036 (0.91)
J	.2751 (6.987)	.2761 (7.013)
K	.259 (6.58)	.263 (6.68)
L	.186 (4.72)	.188 (4.78)
M	.309 (7.85)	.313 (7.95)
N	.031 (0.79)	.033 (0.84)
P	.271 (6.88)	.291 (7.39)
R	.088 (2.24)	.098 (2.49)
S	.000 (0.00)	.006 (0.15)
T	.0330 (0.838)	.0340 (0.864)
U	.219 (5.56)	.281 (7.14)
V	.238 (6.05)	.240 (6.10)
W	.002 (0.05)	.008 (0.20)
X	.0837 (2.126)	.0847 (2.151)
Y	.060 (1.52)	.064 (1.63)
Z	.015 (0.38)	.035 (0.89)

FIGURE 409-2. Interface, test connector, series QNC, socket contact – Continued.

MIL-STD-348B
 w/CHANGE 2

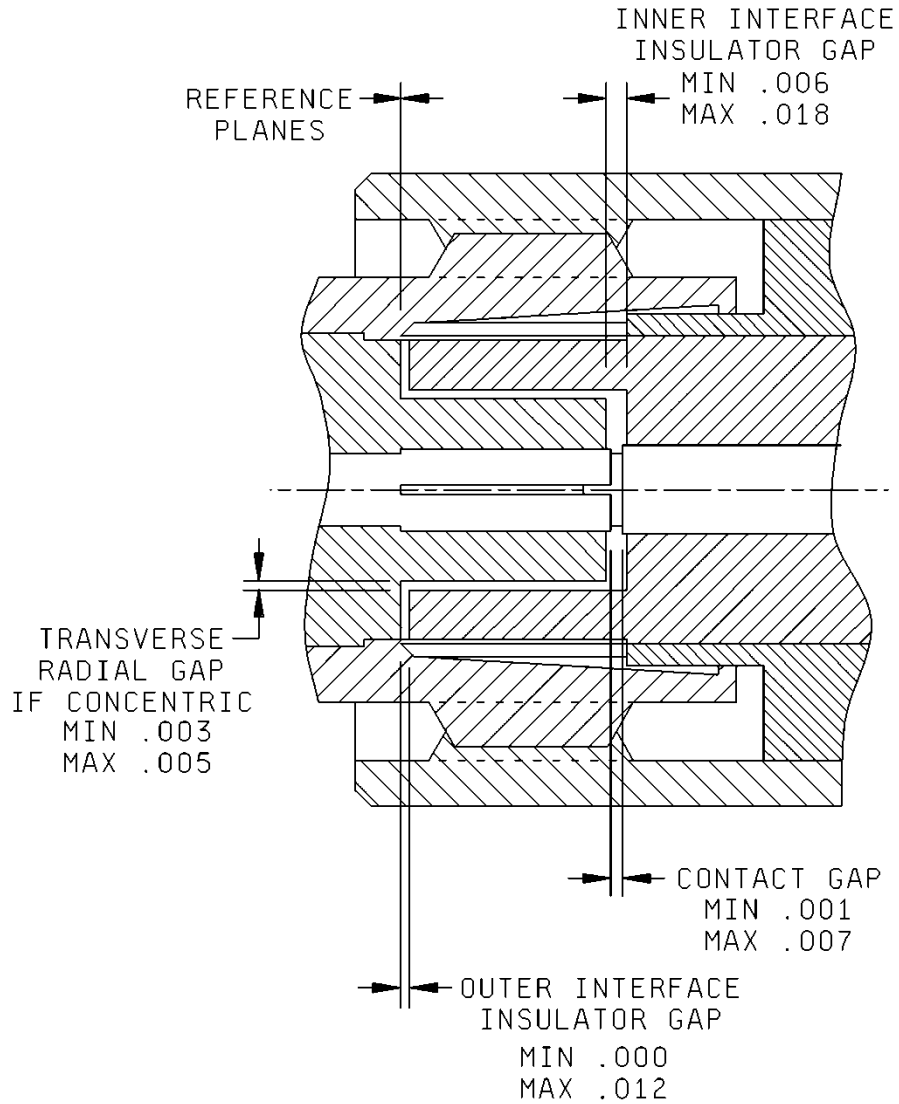

Inches	(mm)
.001	0.03
.003	0.08
.005	0.13
.006	0.15
.007	0.18
.012	0.30
.018	0.46

FIGURE 409-3. Gap of mated standard test connector, series QNC.

MIL-STD-348B
 w/CHANGE 2

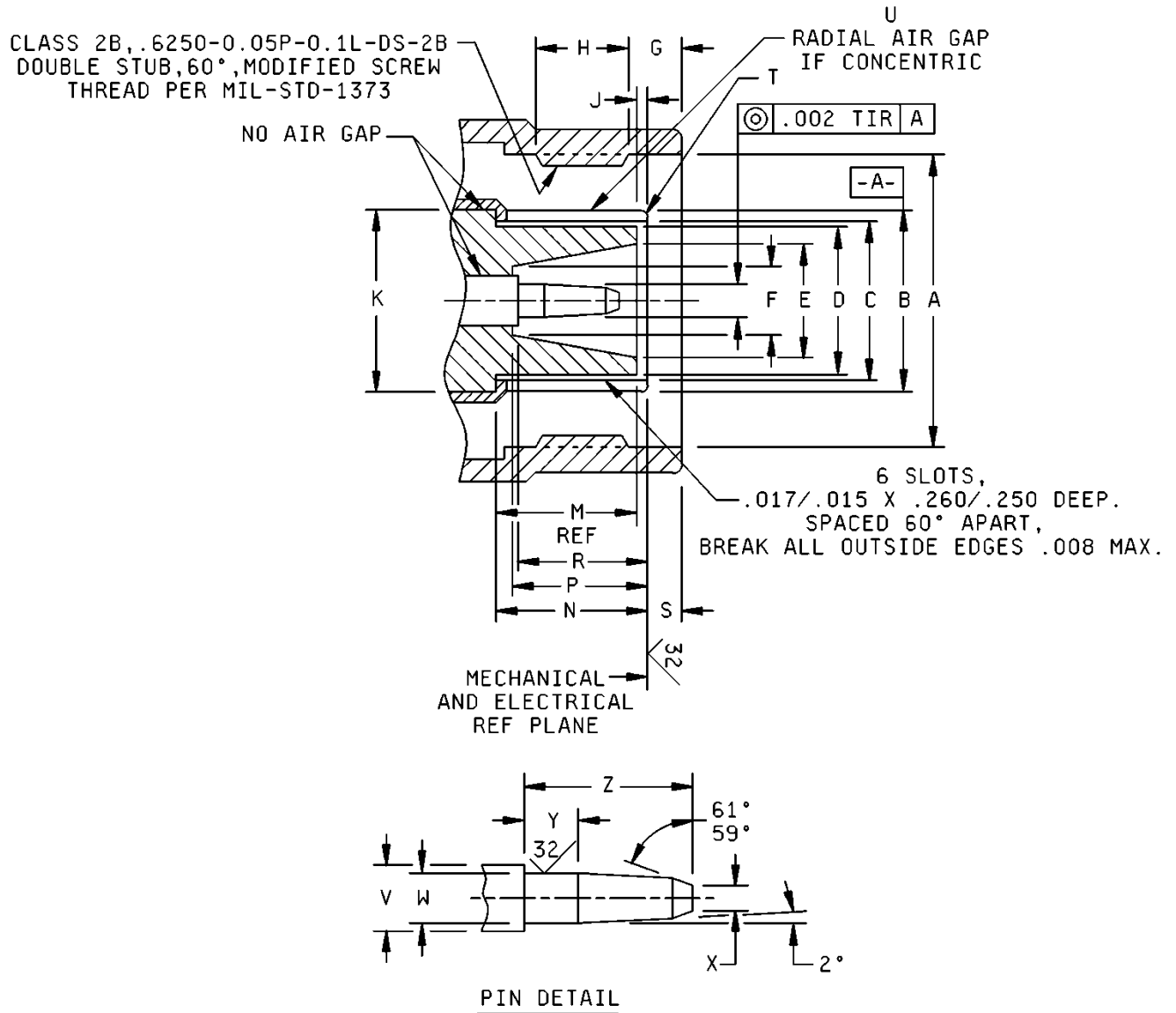

FIGURE 410-1. Interface, test connector, series QSC, pin contact.

MIL-STD-348B
 w/CHANGE 2

Dim Ltr	Inches (mm)	
	Minimum	Maximum
A	.639 (16.23)	.645 (16.38)
B	.412 (10.46)	.414 (10.52)
C	.3815 (9.69)	.3825 (9.72)
D	.375 (9.53)	.379 (9.63)
E	.286 (7.26)	.290 (7.37)
F	.198 (5.03)	.202 (5.13)
G	.088 (2.24)	.098 (2.49)
H	.271 (6.88)	.291 (7.39)
J	.007 (0.18)	.013 (0.33)
K	.3915 (9.94)	.3925 (9.97)
M	.350 (8.89) Reference	
N	.359 (9.12)	.361 (9.17)
P	.312 (7.92)	.318 (8.08)
R	.306 (7.77)	.309 (7.85)
S	-----	.085 (2.16)
T	.005 (0.13) Rad.	.008 (0.20) Rad.
U	.0025 (.06)	
V	.1192 (3.03)	.1202 (3.05)
W	.0905 (2.30)	.0915 (2.32)
X	.041 (1.04)	.051 (1.30)
Y	.035 (0.89)	.045 (1.14)
Z	.182 (4.62)	.192 (4.88)

FIGURE 410-1. Interface, test connector, series QSC, pin contact – Continued.

MIL-STD-348B
 w/CHANGE 2

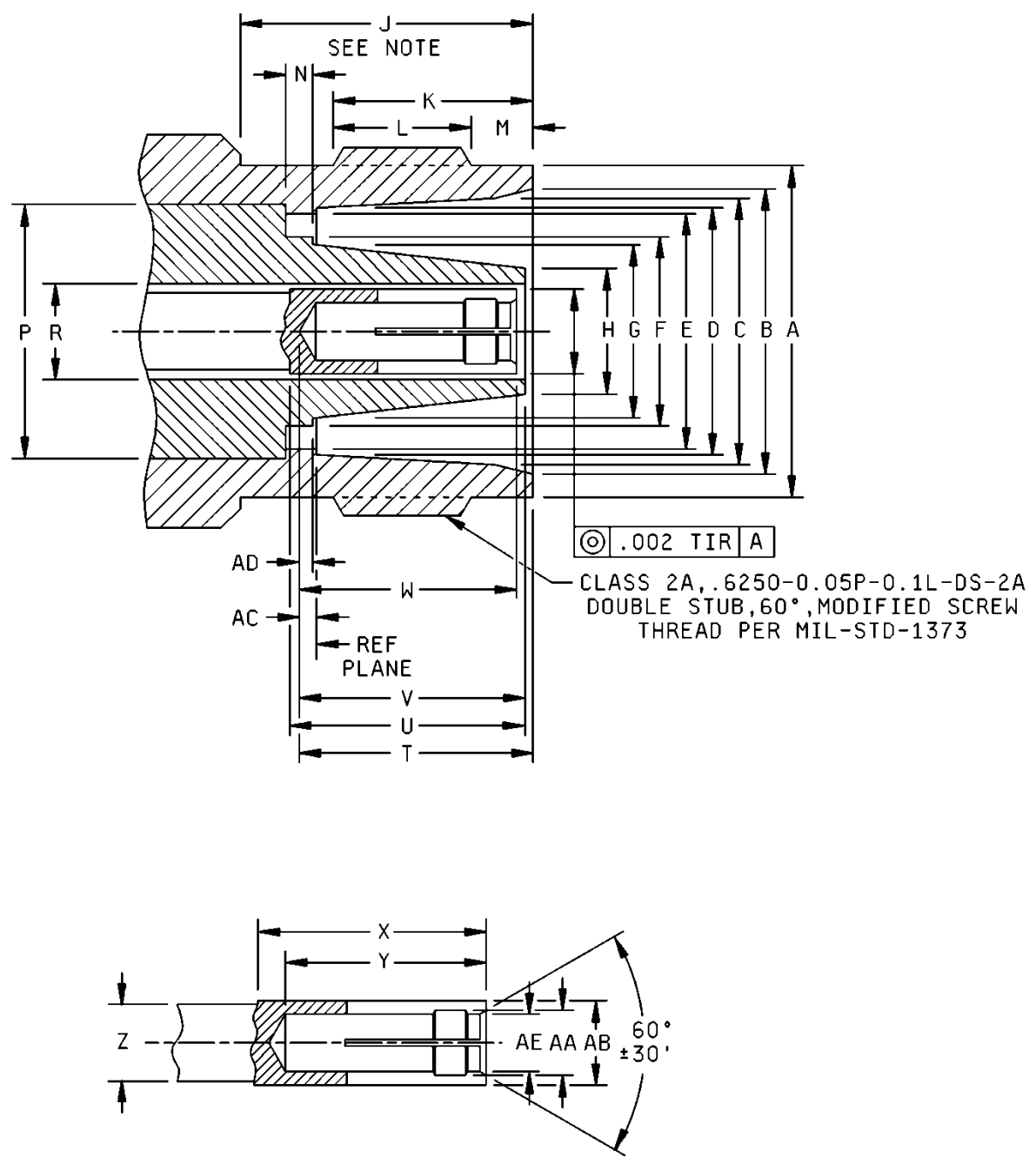

FIGURE 410-2. Interface, test connector, series QSC, socket contact.

**MIL-STD-348B
 w/CHANGE 2**

Dim Ltr	Inches (mm)	
	Minimum	Maximum
A	.571 (14.50)	.574 (14.58)
B	.485 (12.32)	.495 (12.57)
C	.440 (11.18)	.450 (11.43)
D	.411 (10.44)	.415 (10.54)
E	.381 (9.68)	.383 (9.73)
F	.298 (7.57)	.302 (7.67)
G	.258 (6.55)	.262 (6.65)
H	.182 (4.62)	.186 (4.72)
J	.495 (12.57)	-----
K	.371 (9.42)	.377 (9.58)
L	.271 (6.88)	.291 (7.39)
M	.088 (2.24)	.098 (2.49)
N	.031 (.79)	.033 (.84)
P	.3915 (9.94)	.3925 (9.97)
R	.127 (3.23)	.129 (3.28)
T	.304 (7.72)	.306 (7.77)
U	.388 (9.86) nominal	
V	.303 (7.70)	.309 (7.85)
W	.300 (7.62)	.303 (7.70)
X	.337 (8.56) nominal	
Y	.325 (8.26)	-----
Z	.1192 (3.030)	.1202 (3.050)
AA	.097 (2.46)	.101 (2.57)
AB	.1255 (3.19)	.1265 (3.21)
AC	.020 (0.51)	.040 (1.02)
AD	.001 (0.02)	.007 (0.18)
AE	.0905 (2.30)	.0915 (2.32)

NOTE: Clearance for mating coupling nut.

FIGURE 410-2. Interface, test connector, series QSC, socket contact – Continued.

MIL-STD-348B
 w/CHANGE 2

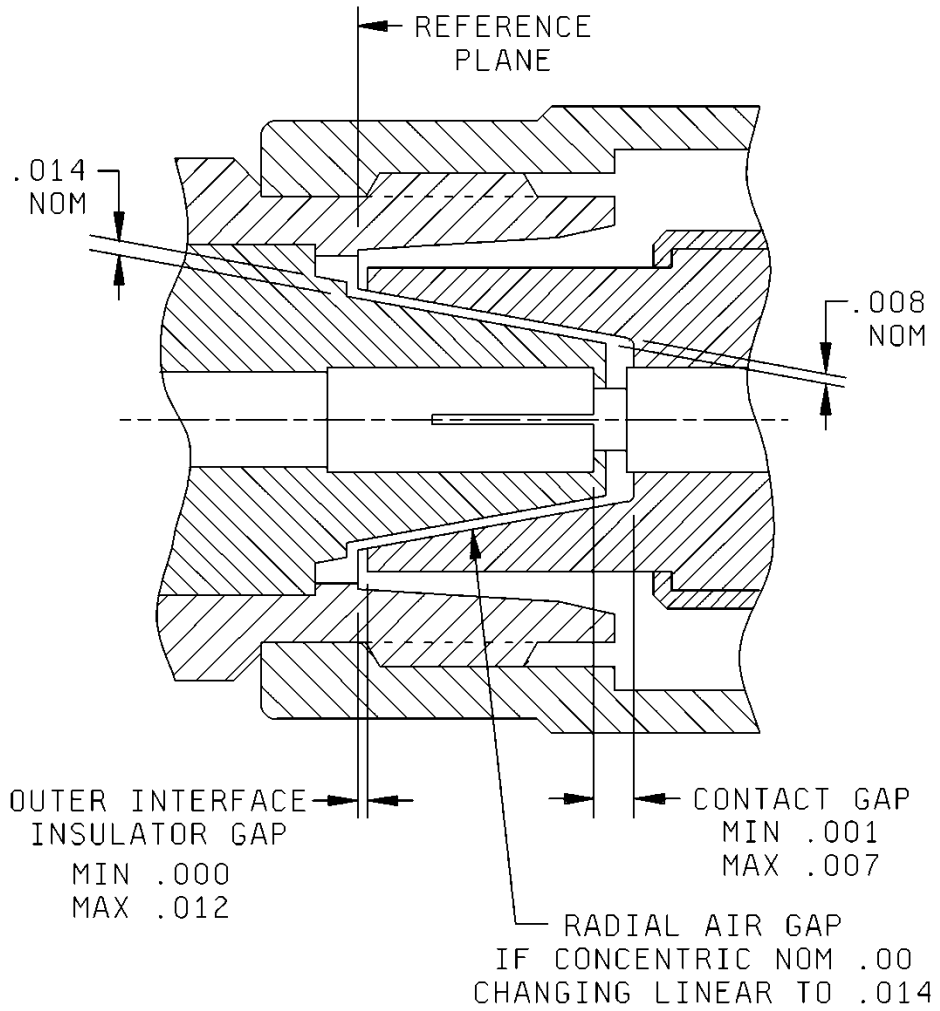

Inches	(mm)
.000	(0.00)
.001	(0.02)
.007	(0.18)
.008	(0.20)
.012	(0.30)
.014	(0.36)

FIGURE 410-3. Gap of mated standard test connector, series QSC.

MIL-STD-348B
w/CHANGE 2

Concluding Material

Custodians:

Army – CR
Navy – EC
Air Force – 85
DLA – CC

Preparing activities:

DLA – CC

(Project 5935-2015-195)

Review activities:

Army – AT, AV, MI
Navy – AS, CG, MC, SH
Air Force – 99

NOTE: The activities listed above were interested in this document as of the date of this document. Since organizations and responsibilities can change, you should verify the currency of the information above using the ASSIST Online database at <https://assist.dla.mil>.