

NOTE The cover page of this standard has been changed for administrative reasons. There are no other changes to this document.

NOT MEASUREMENT
SENSITIVE

MIL-STD-642L

15 May 1991

SUPERSEDING

MIL-STD-642K

13 August 1982

DEPARTMENT OF DEFENSE
STANDARD PRACTICE

IDENTIFICATION MARKING OF COMBAT
AND TACTICAL TRANSPORT VEHICLES



AMSC N/A

FSC 2310, 2320, 2330, 2340, 2350, 2430

DISTRIBUTION STATEMENT A. Approved for public release; distribution is unlimited

MIL-STD-642L

F O R E W O R D

1. This military standard is approved for use by all Departments and Agencies of the Department of Defense.

2. Beneficial comments (recommendations, additions, deletions) and any pertinent data which may be of use in improving this document should be addressed to: U.S. Army Tank-Automotive Command, ATTN: AMSTA-GDS, Warren, MI 48397-5000, by using the self addressed Standardization Document Improvement Proposal (DD Form 1426) appearing at the end of this document, or by letter.

3. This standard establishes requirements for the marking of combat and tactical transport type vehicles of the Department of Defense and provides a reference for procurement actions. The marking of administrative vehicles is covered by MIL-STD-1223.

MIL-STD-842L

C O N T E N T S

<u>PARAGRAPH</u>		<u>PAGE</u>
1.	SCOPE	1
1.1	Scope	1
1.2	Purpose	1
1.3	Special vehicles	1
2.	APPLICABLE DOCUMENTS	2
2.1	Government documents	2
2.1.1	Specifications, standards, and handbooks	2
2.1.2	Other Government documents, drawings, and publications	3
2.2	Order of precedence	3
3.	DEFINITIONS (Not applicable)	4
4.	GENERAL REQUIREMENTS	5
4.1	Registration markings	5
4.1.1	Agency identification and registration markings on camouflaged Army vehicles	5
4.2	Special markings	5
4.2.1	Heavy military vehicles	5
4.2.2	Application of national symbol	5
4.2.3	Ambulance markings	5
4.2.4	Fuel tanker safety markings	6
4.3	Concealed markings	6
4.4	Registration markings for military vehicles supplied to foreign nations	6
5.	DETAILED REQUIREMENTS	7
5.1	Vehicle marking	7
5.1.1	Locations and markings	7
5.1.2	Style, size and spacing of markings	7
5.1.3	Application of markings	7
5.1.3.1	Marking paint	7
5.1.3.2	Adhesive backed markings	7
5.1.4	Colors	8
5.2	National symbol	8
5.2.1	Symbol size	8
5.2.2	Symbol location	8
5.2.2.1	Army vehicles	8
5.2.3	Symbol color	9
5.3	Ambulance markings	9
5.3.1	Colors	9

MIL-STD-642L

C O N T E N T S

<u>PARAGRAPH</u>		<u>PAGE</u>
6.	NOTES	10
6.1	Intended use	10
6.2	International standardization agreement	10
6.3	Subject term (key word) listing	10
6.4	Changes from previous issue	10
 <u>FIGURES</u>		
1.	National symbol	11
2.	Caduceus, medical service	12
3.	Ambulance (USMC)	13
4.	Ambulance (Army)	14
5.	Tracked vehicles	15
6.	Armored infantry vehicles	17
7.	Hawk loader transporter	18
8.	Towed vehicles	19
9.	Trailers	23
10.	Pershing system vehicle (Tractor configuration)	24
11.	Pershing system vehicle (Van configuration)	25
12.	Pershing system vehicle (Truck configuration)	26
13.	Trucks and truck tractors	27
14.	Trucks	29
15.	Utility vehicles	30
16.	Style of marking letters	31
17.	Arrangement of U.S. Army marking	32
18.	Arrangement of U.S. Navy marking	33
19.	Arrangement of U.S. Air Force marking	34
20.	Arrangement of U.S. Marine Corps marking	35

MIL-STD-6420

1. SCOPE

1.1 Scope. This standard covers mandatory requirements for marking military tactical and tracked vehicles, self propelled guns and transport vehicles.

1.2 Purpose. The purpose of this standard is to provide a uniform system for marking combat and tactical transport vehicles and implements International Standardization Agreements (STANAGs) on marking of military vehicles (see 6.3).

1.3 Special vehicles. Special vehicles that are to have concealed markings are exempted from the requirements of this standard (see 4.3).

MIL-STD-642L

2. APPLICABLE DOCUMENTS

2.1 Government documents.

2.1.1 Specifications, standards, and handbooks. The following specifications, standards and handbooks form a part of this document to the extent specified herein. Unless otherwise specified, the issues of these documents are those listed in the issue of the Department of Defense Index of Specifications and Standards (DODISS) and supplement thereto, cited in the solicitation (see 6.2).

SPECIFICATIONS

FEDERAL

- | | |
|----------|--|
| A-A-1558 | - Paint, Stencil. |
| L-S-300 | - Sheetting and Tape, Reflective,
Non-Exposed Lens. |
| TT-E-529 | - Enamel, Alkyd, Semi-gloss: Low VOC content. |

MILITARY

- | | |
|---------------|--|
| MIL-M-43719 | - Marking, Materials and Markers, Adhesive,
Elastomeric, Pigmented; General Specification
for. |
| MIL-M-43719/2 | - Marking Materials and Markers, Adhesive,
Elastomeric, Pigmented; Legends. |
| MIL-M-43719/3 | - Marking Materials and Markers, Adhesive,
Elastomeric, Pigmented; Symbols. |
| MIL-C-46168 | - Coating, Aliphatic Polyurethane, Chemical
Agent Resistant. |
| MIL-C-53039 | - Coating, Aliphatic Polyurethane, Single
Component. Chemical Agent Resistant. |

STANDARD

FEDERAL

- | | |
|-------------|----------|
| FED-STD-595 | - Color. |
|-------------|----------|

(Unless otherwise indicated, copies of federal and military specifications, standards, and handbooks are available from the Navy Publication and Printing Service Office, Standardization Documents Order Desk, Bldg 4D, 700 Robbins Avenue, Philadelphia, PA 19111-5094.)

MIL-STD-642L

2.1.2 Other Government documents, drawings, and publications. The following other Government documents, drawings and publications form a part of this document to the extent specified herein. Unless otherwise specified the issues are those cited in the solicitation (see 6.2).

DRAWINGS

11644801 - Insignia, Army Medical Service.

(Copies of drawings, publications, and other Government documents required by the contractors in connection with specific acquisition functions should be obtained from the contracting activity or as directed by the contracting officer.)

2.2 Order of precedence. In the event of a conflict between the text of this document and the references cited herein, the text of this document takes precedence. Nothing in this document, however, supersedes applicable laws and regulations unless a specific exemption has been obtained.

MIL-STD-642L

3. DEFINITIONS

This section is not applicable to this standard.

MIL-STD-6426

4. GENERAL REQUIREMENTS

4.1 Registration markings. Registration markings applied to vehicles within the scope of this standard shall consist of the military department identification ("U S A F", "U S N" or "U S M C", whichever is applicable) and the military registration number assigned. "U S ARMY" shall not be used on the exterior of vehicles during manufacture or overhaul; however, the registration number shall be applied. Except for self-propelled guns, tanks and as otherwise specified herein, the registration numbers shall be applied on both sides and on the rear of each vehicle in a location to be readily visible. The rear markings shall not be obscured by the spare tire carrier or any other accessory or part of the vehicle. Registration markings shall not be applied to mounted equipment on vehicles without the prior approval of the procuring activity.

4.1.1 Agency identification and registration markings on camouflaged Army vehicles. Agency identification and registration markings are not permitted on any visible exterior surface of camouflaged Army vehicles and shall be located in accordance with 4.3.

4.2 Special markings. Unit identification markings shall be applied upon receipt by the using service. Safety markings specified on vehicle drawings or specifications shall be applied at the time of manufacture/rebuild. Additional safety markings may be applied upon receipt by the using service. For Army vehicles painted with camouflage colors, instructional markings shall be lusterless black continuous characters one inch in height.

4.2.1 Heavy military vehicles. Markings to be placed on heavy vehicles used by NATO armed forces in Continental Western Europe shall conform to NATO STANAG 2153, and shall be applied upon receipt by the using service.

4.2.2 Application of National Symbol. Unless otherwise specified in military procurement documents, the National Symbol, a white (black for Army vehicles) 5-pointed star (see 5.2 and figure 1) shall be applied on all vehicles destined for direct delivery to U.S. Military or National Guard units and test sites. The symbol shall not be applied on vehicles intended for foreign military sales, Grant-Aid shipments or vehicles destined for U.S. Army Depots. The symbol shall not be applied on ambulances or other medical service vehicles affected by International Agreement concerning such vehicles.

4.2.3 Ambulance markings. Ambulance markings (see 5.3 and figures 2, 3 and 4) shall be applied by the manufacturer.

MIL-STD-642L

4.2.4 Fuel tanker safety markings. New vehicle production fuel tankers (bulk haul and fuel servicing) shall have a means by which required safety signs in CONUS will contain the following markings, which can be securely fastened to each side and rear of the vehicle:

- a. "FLAMMABLE" in 6-inch block letters, one inch border all around.
- b. "NO SMOKING WITHIN 50 FEET" in 3-inch block letters, one inch border all around.

4.3 Concealed markings. Vehicles requiring concealed markings shall have those markings applied on a concealed but accessible interior surface and shall be readily visible, such as, on the inside of the map compartment lid. Army concealed markings shall be on any appropriate area which is visible from outside a locked and secured vehicle, or if the vehicle is not so configured, on a readily accessible concealed exterior surface, such as, on the inside of a tool box lid. Concealed markings shall be applied using stenciled decal or letters and numerals as large as practicable, but not less than 1/2 inch in height. When painting or application with tape is impractical, markings shall be stamped on a 1 inch by 3 inch nonferrous metal plate and affixed in the above prescribed locations.

4.4 Registration markings for military vehicles supplied to foreign nations. Vehicles supplied to foreign nations under Military Assistance Programs (MAP) shall have temporary registration numbers placed on metal or wood tags, painted yellow, and attached in readily visible areas of the vehicle. Such markings shall remain affixed to the vehicle until arrival at foreign destination. The Military Assistance Advisory Groups (MAAG) shall be responsible for removing such markings and, in the case of metal or wood tags, for insuring that they are removed and destroyed.

MIL-STD-642L

5. DETAILED REQUIREMENTS

5.1 Vehicle marking. Vehicles shall be marked with the military identification and registration number, and other special markings as specified herein.

5.1.1 Locations and markings. Locations of markings shall conform to figures 3 through 15, except where obstructions or configuration of the vehicle interferes with legibility. Markings on the side opposite the side shown in the figures shall be similarly marked. For new vehicles, the procuring activity reserves the right of final approval for marking locations. For Marine Corps markings, the letters "U S M C" and the registration number shall be on one line, wherever practicable.

5.1.2 Style, size and spacing of markings. The markings shall conform to figures 16 through 20. Markings shall be uniformly applied using numerals and letters 1, 2, 3, 4 or 5 inches in height (Army, 4 inches maximum). The use of the largest size practicable in the available space will be the determining factor in choosing letter and numeral size. On vehicles painted lusterless camouflage colors, registration numbers (characters) shall be gothic, no larger than 4 inches high. Where space permits, markings shall have a single space between individual letters and numerals, and letter and numeral groups shall be separated by 2 spaces, minimum. Except as otherwise specified herein, markings shall be applied using stenciled or decal letters and numbers.

5.1.3 Application of markings. Markings of tactical and combat vehicles covered by this standard shall be applied with the use of marking paint (see 5.1.3.1) or adhesive backed markers (see 5.1.3.2). Marking paint shall be used for applications on fabrics such as canvas or other extremely rough surfaces.

5.1.3.1 Marking paint. Marking paint shall conform to MIL-C-46168, MIL-C-53039, TT-E-529, Class 1 or A-A-1558, Class 1 as required to provide the specified finish.

5.1.3.2 Adhesive backed markings. Marking materials shall conform to Type II, Class 1 of MIL-M-43719 for nonreflective markers. Reflective markers shall be of material conforming to Federal Specification L-S-300, Type I or II, Class 3, reflectivity 1. The National Symbol, Red Cross Emblem and Medical Service Insignia shall also conform to MIL-M-43719/3. All other markings shall conform to MIL-M-43719/2 and to 5.1.2 of this standard.

MIL-STD-642L

5.1.4 Colors. Color of markings shall conform, as applicable, to color chips of FED-STD-595 as follows:

- a. Lusterless white No. 37875 shall be used on vehicles painted with dark lusterless or semi-gloss colors.
- b. Lusterless black No. 37038 shall be used on vehicles painted with lusterless forest green and camouflage colors.
- c. Semi-gloss yellow No. 23538 shall be used on vehicles painted Standard Marine Corps green semi-gloss.
- d. Lusterless yellow No. 33538 shall be used on vehicles painted Standard Marine Corps green lusterless.

5.2 National symbol.

5.2.1 Symbol size. The star shall be of the largest size practicable but shall not exceed 36 inches in diameter inclosing the outer points. The National Symbol (Star) shall not be applied where space does not permit the use of a star to fit into a 3 inch diameter circle minimum. For Army vehicles, the star shall be lusterless black of a size to fit into a 3 inch diameter circle placed at front and rear of vehicle only.

5.2.2 Symbol location. With the exception of Army vehicles, the symbol shall be applied on the front, rear, top and both sides of the vehicles to permit ready identification from all directions (see figures 5 through 17). The symbol shall be located on the largest regular area and as near as possible to the center of each surface, but not in a position where it will be obscured by canvas items, folded-down windshields, gasoline cans, pioneer tools, communications equipment or other items. The symbol shall only be applied to canvas surfaces if there is no other adequate perspicuous location available. On horizontal surfaces, one point of the star shall point directly toward the front of the equipment, and on vertical surfaces, one point shall point squarely up. On tactical transport vehicles, the symbol shall be located on top surfaces in the following order of preference:

- a. On the roof of vehicles with hard roof bodies.
- b. On the top surface of the cab of vehicles with hard cabs but not having hard roof bodies.
- c. On the top surface of the hood when no other suitable hard surface of adequate size is available.

5.2.2.1 Army vehicles. When specified for Army vehicles, the star shall be applied on combat, tactical and related equipment, including support and special vehicles in CONUS and overseas. It is not to be applied to vehicles and equipment assigned to TOE medical units or to ground support equipment at Army airfields in CONUS. The star is to be applied, one each, centered on front and rear, on any suitable surface such as bumpers and tailgates, where it will not be obscured by canvas items, gasoline cans, pioneer tools or other objects.

MIL-STD-642L

5.2.3 Symbol color. The color for the National Symbol shall conform to color chip No. 37875, lusterless white, of FED-STD-595, except for Army vehicles. For Army vehicles, the color shall conform to No. 37038, lusterless black.

5.3 Ambulance markings. Unless otherwise specified in procurement documents or drawings, ambulance markings shall be applied by the manufacturer and shall consist of at least the following:

- a. The word "AMBULANCE" in 3-inch high letters.
- b. ARMY, NAVY, AIR FORCE or USMC MEDICAL SERVICE, as applicable.
- c. Red Cross Emblem (see figures 3 and 4).
- d. Medical Service Insignia (see figure 2 or drawing 11644801).
- e. On tactical type ambulances, the cross shall be approximately 36 inches to 48 inches square and shall be placed on roof, both sides, rear and front, if practicable.

5.3.1 Colors. Color of the ambulance markings shall conform to color chips of FED-STD-595, as follows:

- a. Gloss red No. 11136 and gloss white No. 17875 shall be used on vehicles painted gloss or semi-gloss olive drab.
- b. Lusterless red No. 31136 and lusterless white No. 37875 shall be used on vehicles painted lusterless forest green.
- c. Lusterless black No. 37038 where applicable.

MIL-STD-842L

6. NOTES

(This section contains information of a general or explanatory nature that may be helpful, but is not mandatory.)

6.1 Intended use. This standard is used to provide a uniform system for marking, identification and registration information on combat and tactical transport vehicles of the Department of Defense.

6.2 Issue of DODISS. When this standard is used in acquisition, the applicable issue of the DODISS must be cited in the solicitation (see 2.1.1 and 2.1.2).

6.3 International standardization agreements. Certain provisions of this standard are the subject of International Standardization Agreements:

- a. National Symbol (see 4.2.2 and figure 1)
 - (1) NATO STANAG 2027 (Edition No. 2).
 - (2) SEATO SEASTAG 2027.
- b. Heavy Vehicle marking (see 4.2.1)
 - (1) NATO STANAG 2153.

When change notice, revision, or cancellation of this standard is proposed that will modify the international agreement concerned, the preparing activity will take appropriate action through international standardization channels, including departmental standardization offices, to change the agreement or make other appropriate accommodations.

6.4 Subject term (key word) listing.

Ambulance markings
Colors
Heavy military vehicles
Marking paint
National symbol
Registration markings

6.5 Changes from previous issue. Marginal notations are not used in this revision to identify changes with respect to the previous issue due to the extensiveness of the changes.

MIL-STD-642G

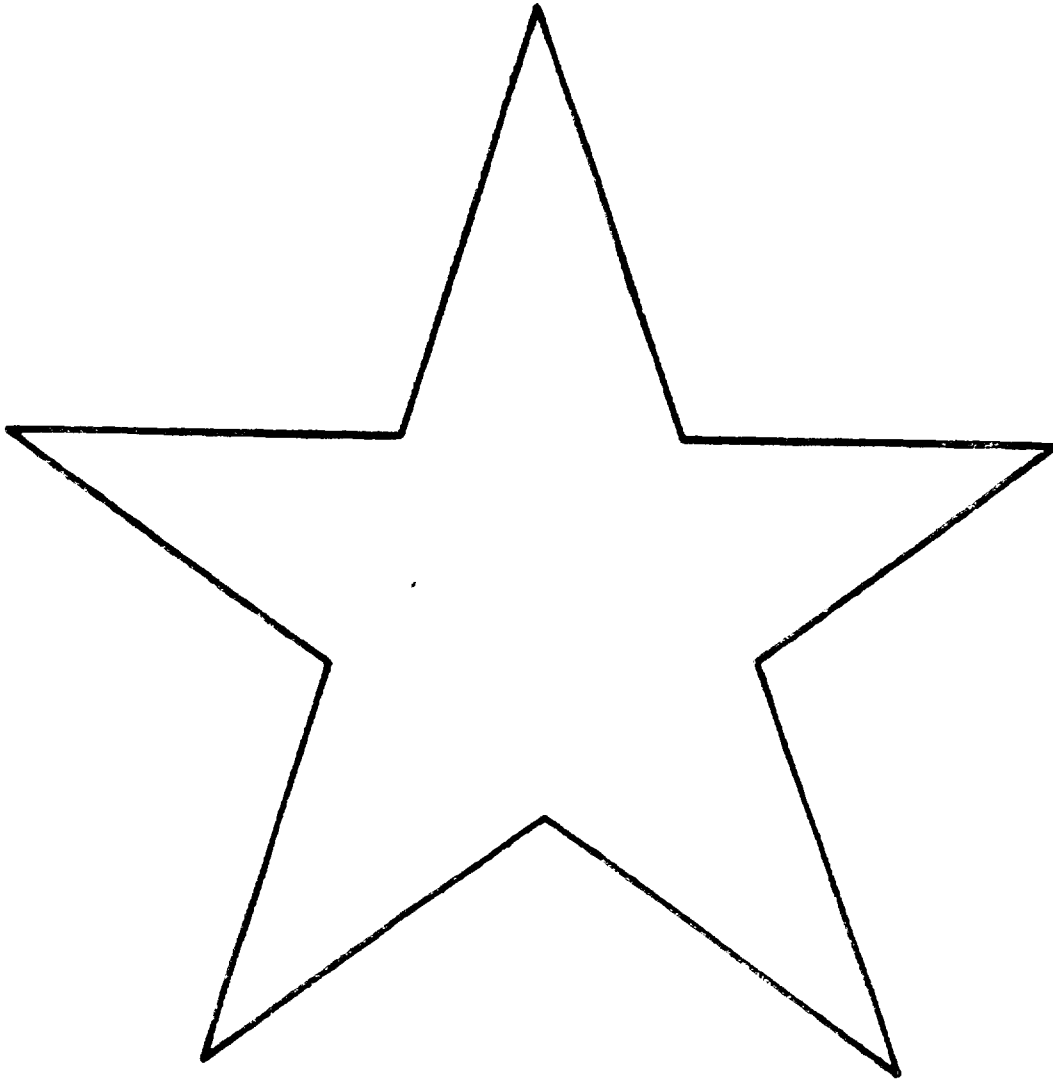
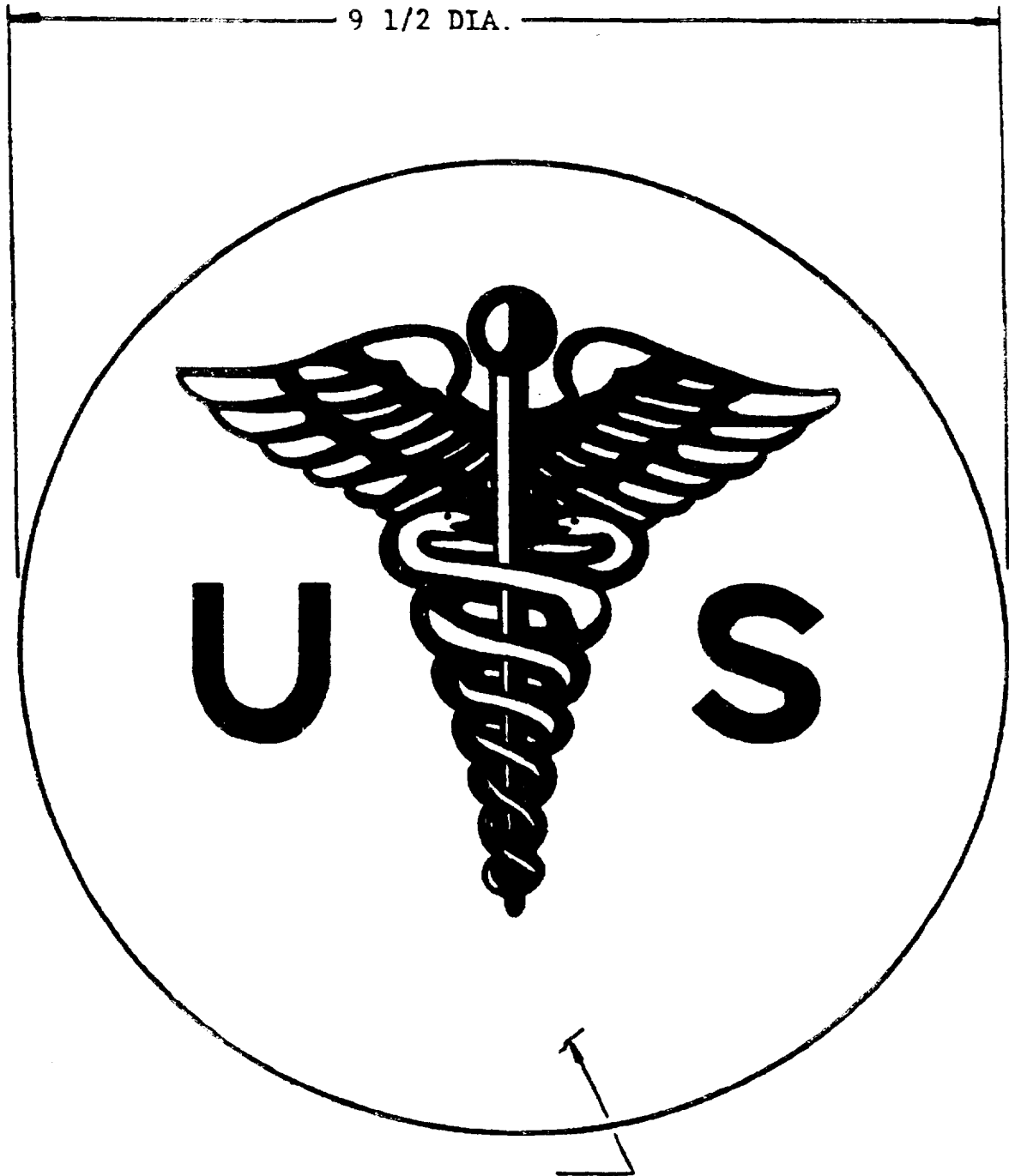

FIGURE 1. National symbol.

MIL-STD-642L



RED CADUCEUS 6 IN. HIGH

U S -1 1/2 IN. HIGH RED

FIGURE 2. Caduceus, medical service.

MIL-STD-642L

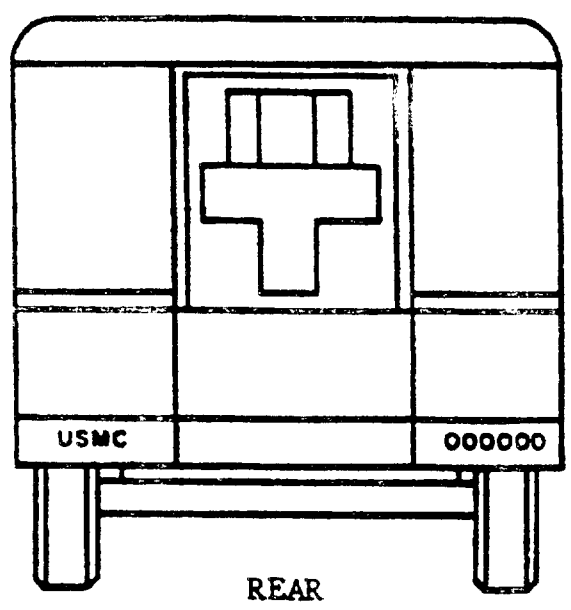
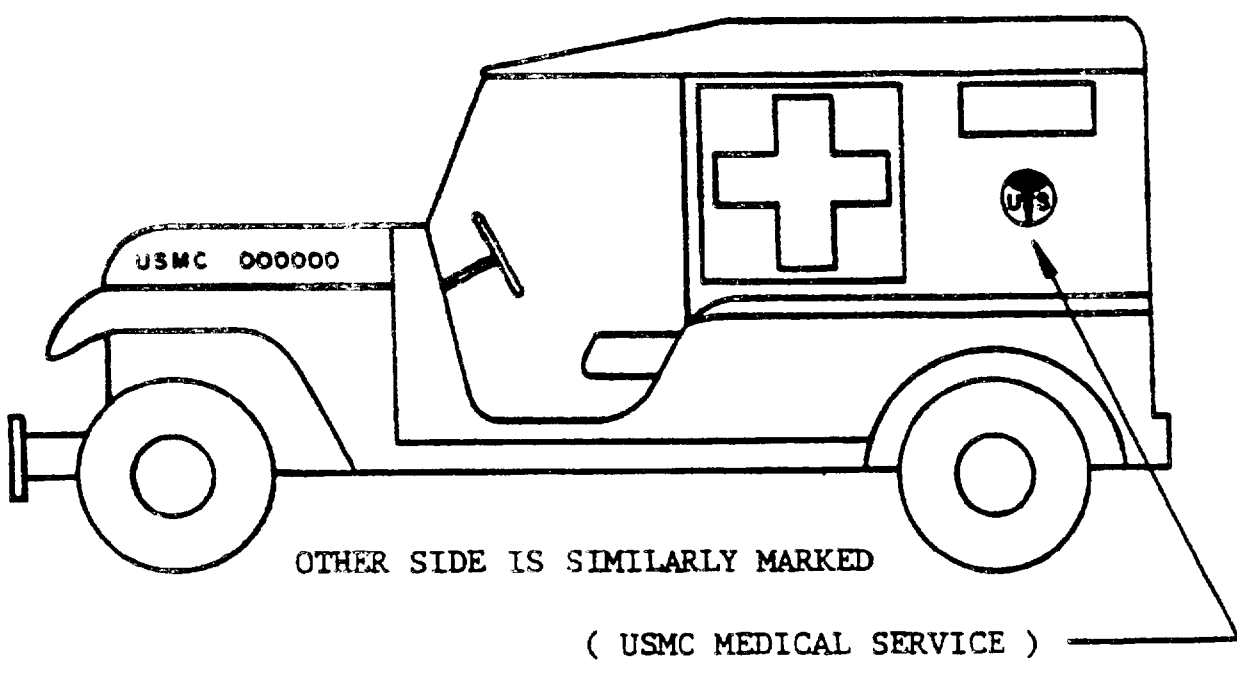
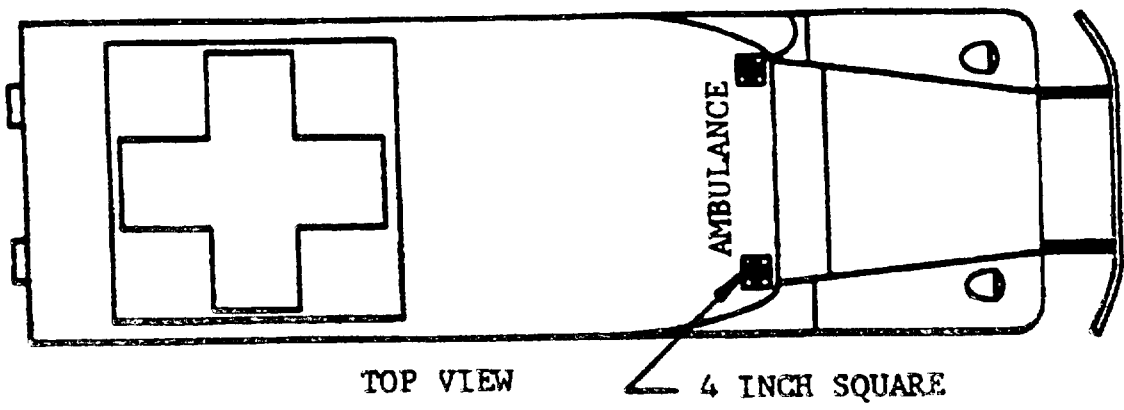
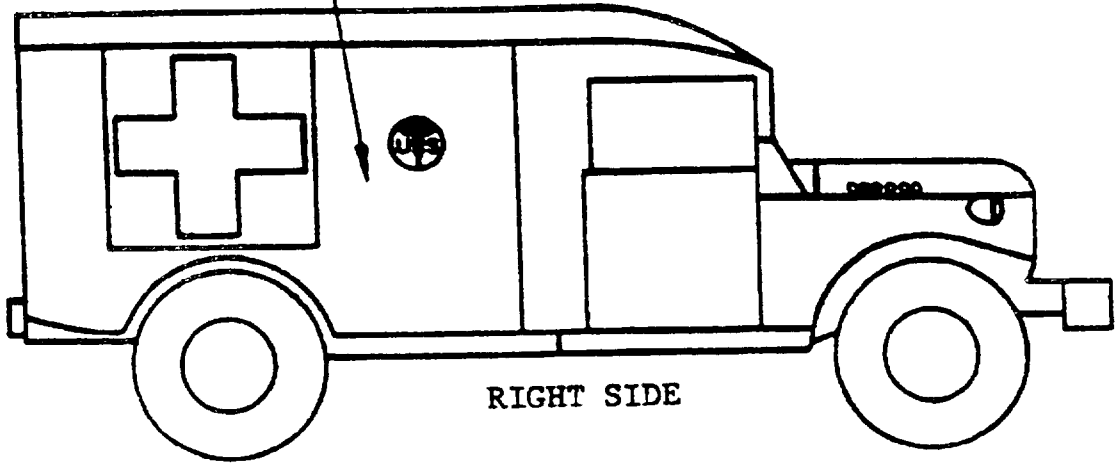

FIGURE 3. Ambulance (USMC).

MIL-STD-642L



(ARMY MEDICAL SERVICE)



(LEFT SIDE IS SIMILARLY MARKED)

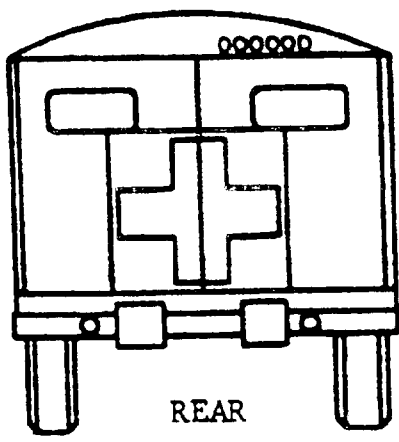
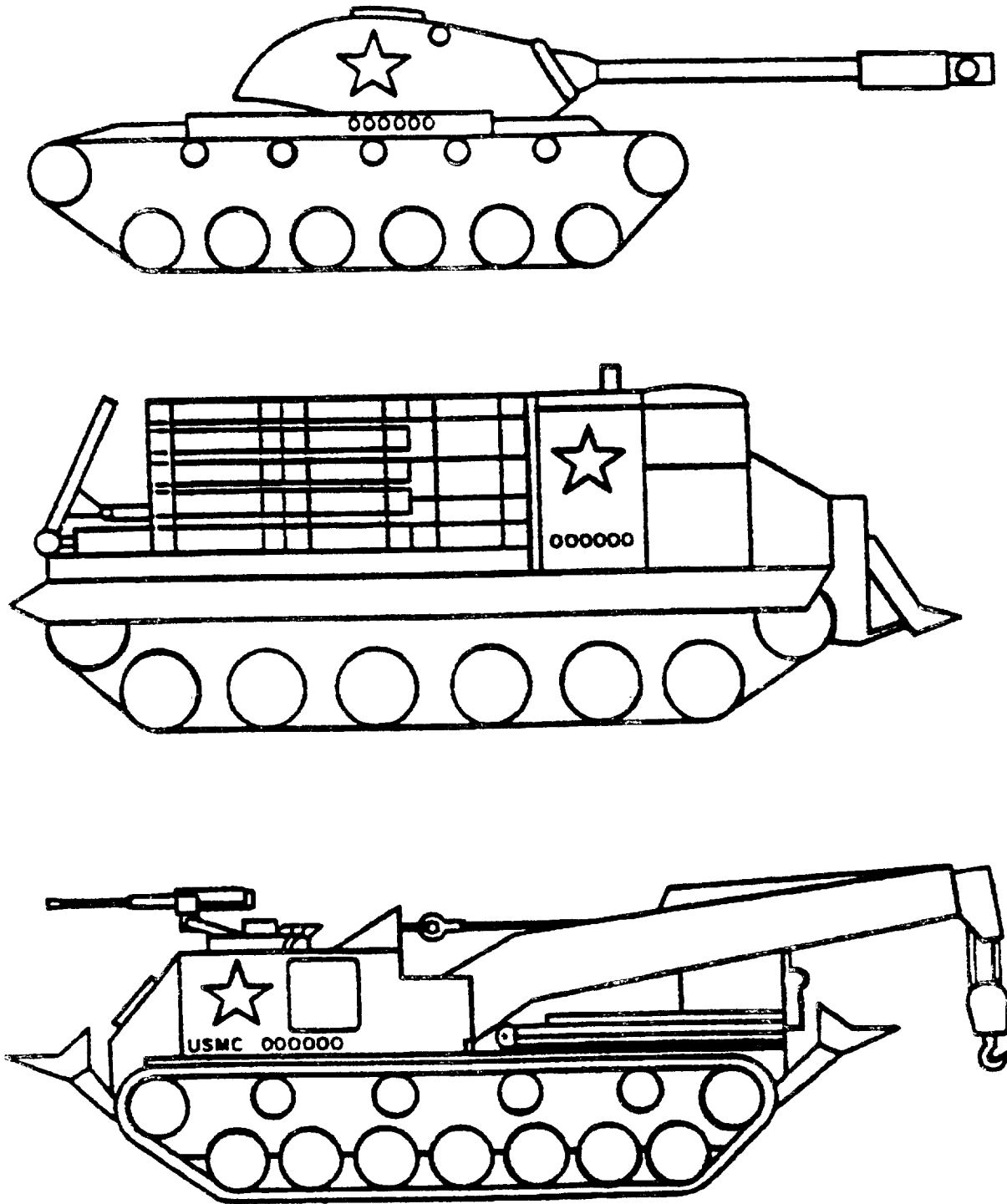

FIGURE 4. Ambulance (Army).

MIL-STD-642L



OPPOSITE SIDE SIMILARLY MARKED.

FIGURE 5. Tracked vehicles.

MIL-STD-642L

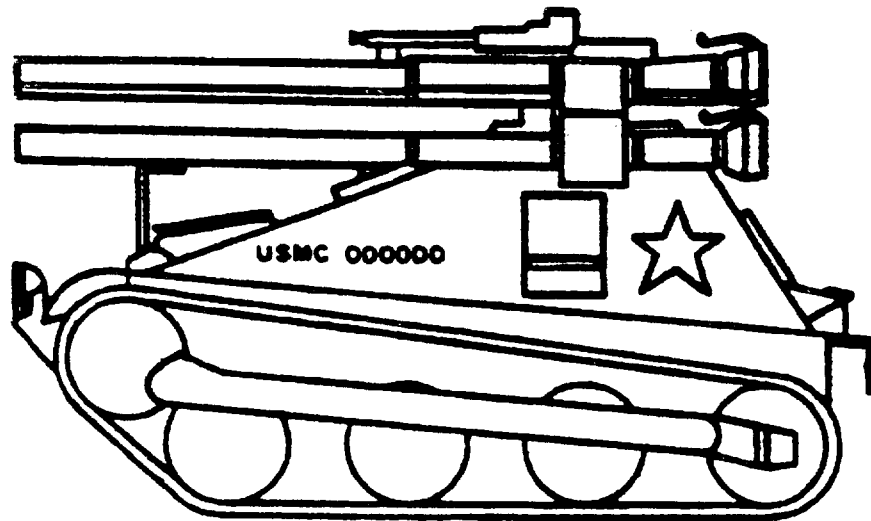
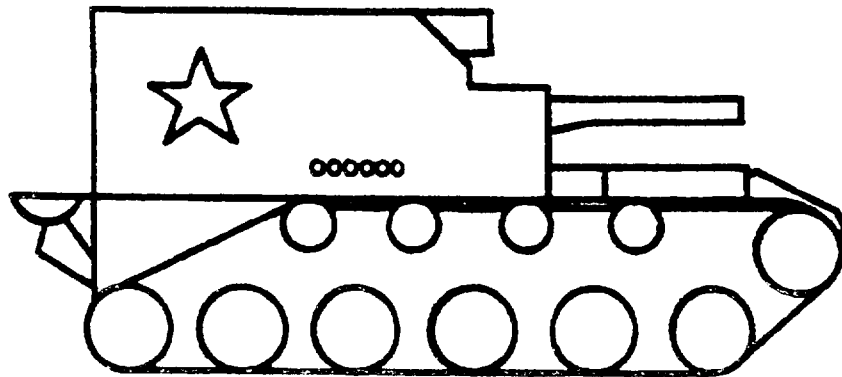

OPPOSITE SIDE
SIMILARLY MARKED

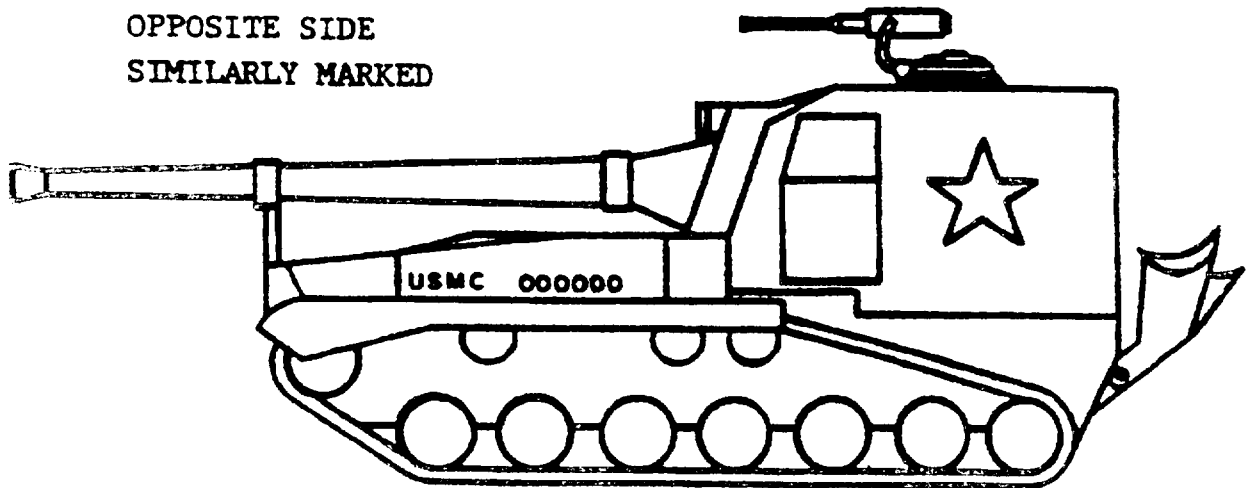

FIGURE 5. Tracked vehicles - Continued.

MIL-STD-642L

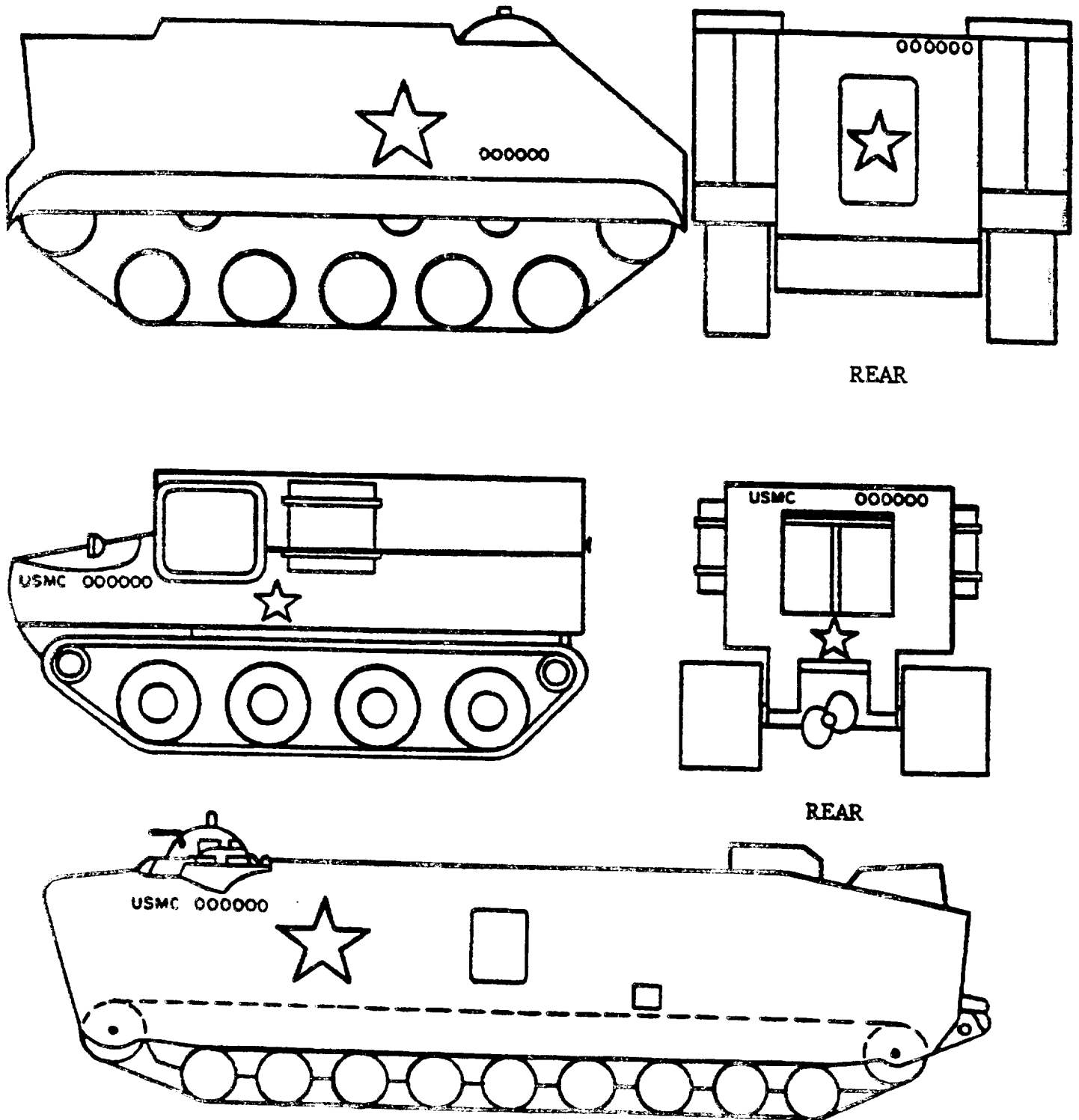
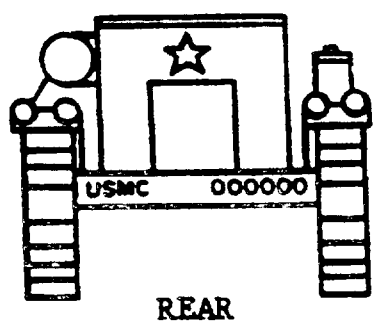
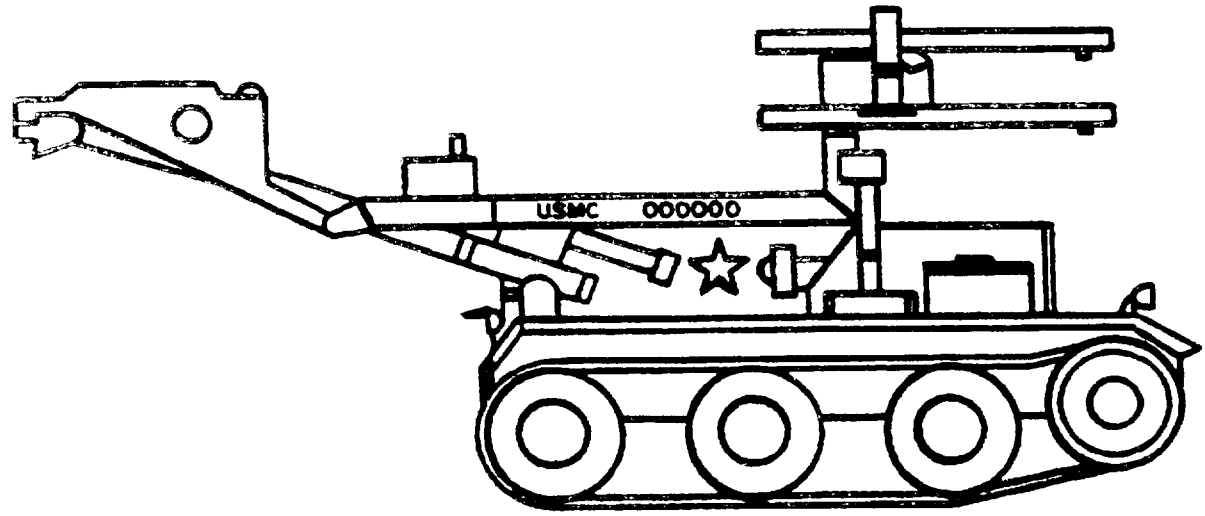
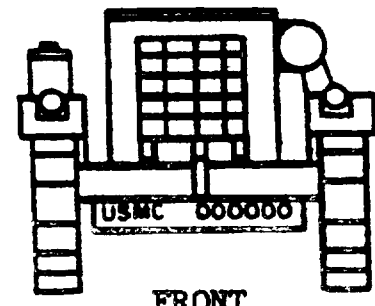

FIGURE 6. Armored infantry vehicles.

MIL-STD-642L



REAR



FRONT

FIGURE 7. Hawk loader transporter.

MIL-STD-642L

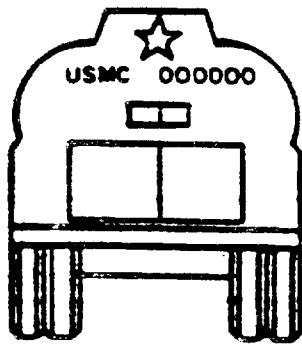
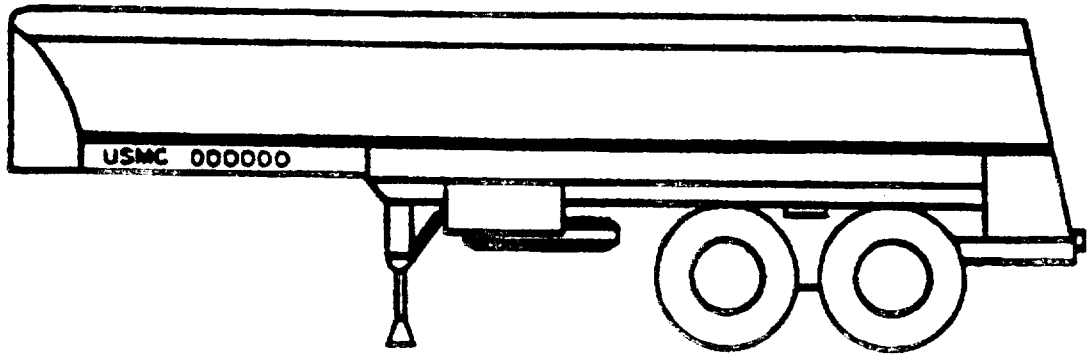

REAR

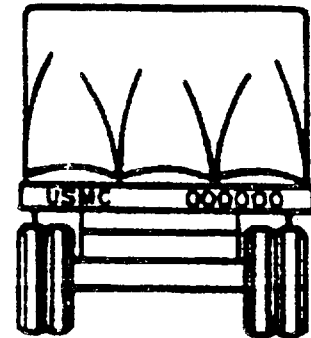

REAR

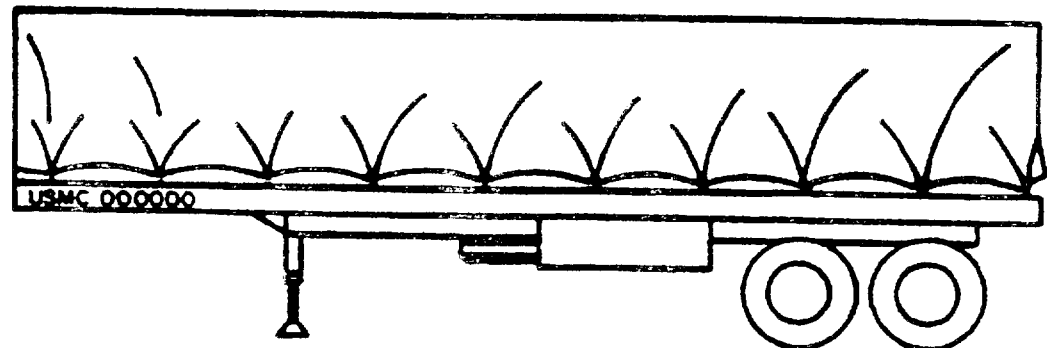

FIGURE 8. Towed vehicles.

MIL-STD-642L

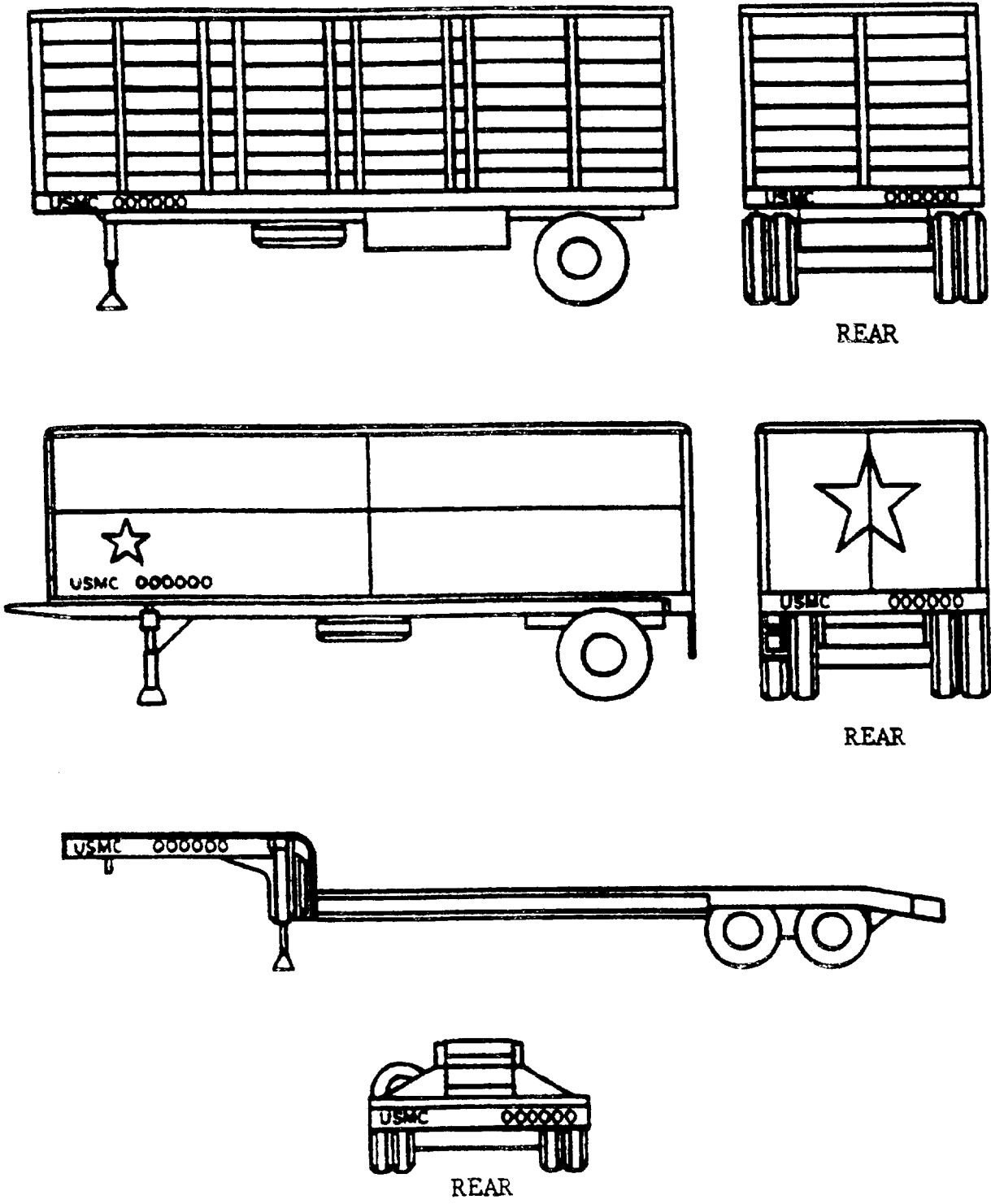
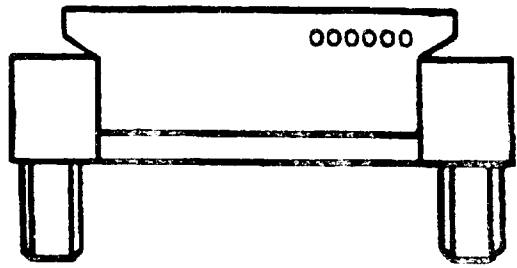
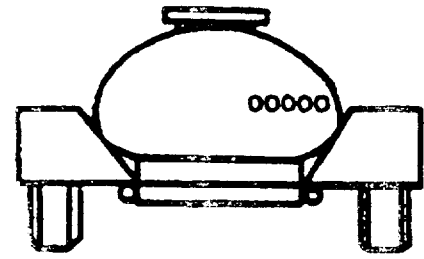

FIGURE 8. Towed vehicles - Continued.

MIL-STD-642L



REAR VIEW



REAR VIEW

TOWED VEHICLES

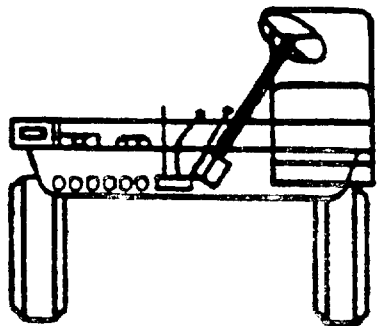

FRONT VIEW

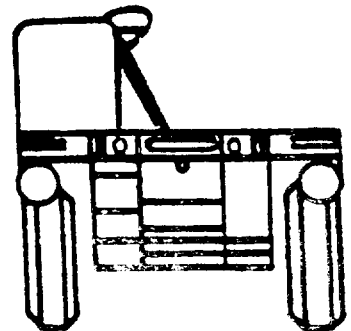

REAR VIEW

CARRIER

FIGURE 8. Towed vehicles - Continued.

MIL-STD-642L

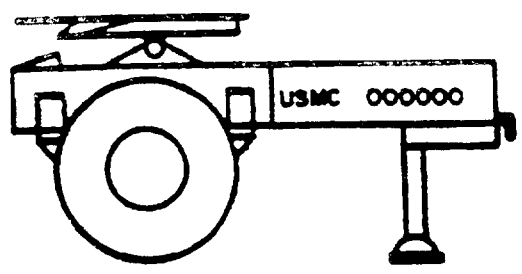

DOLLY CONVERTER

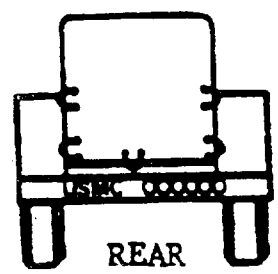

REAR

STEAM CLEANER

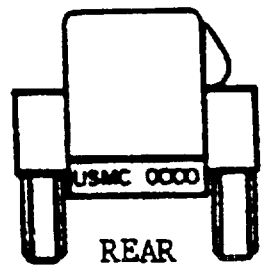

REAR

LUBRICATION

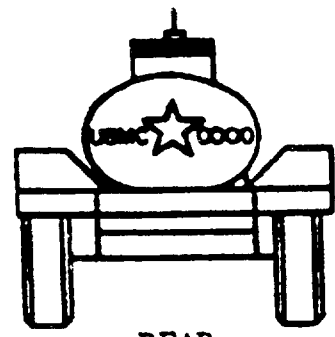
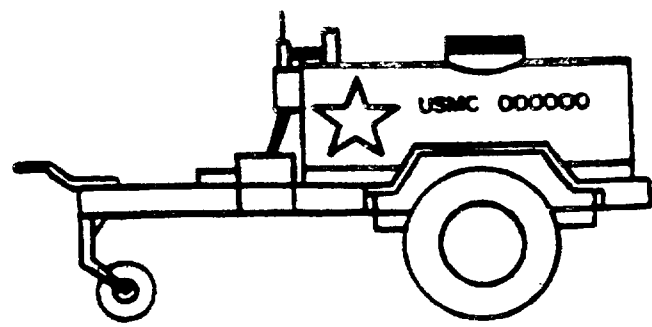

REAR

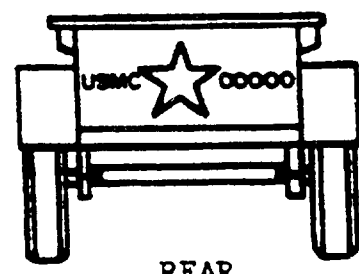
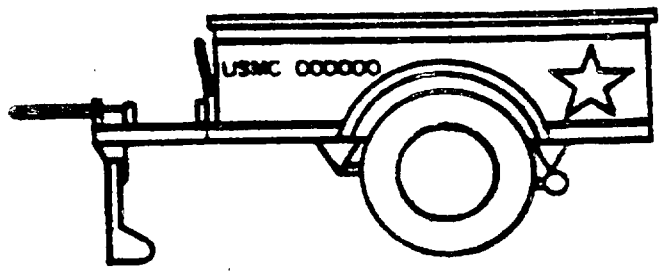

REAR

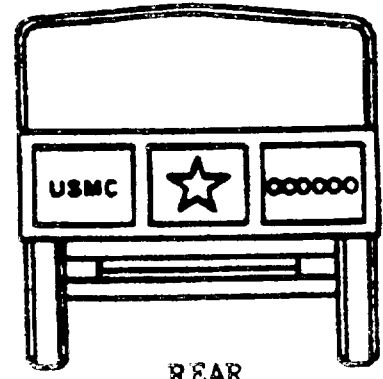
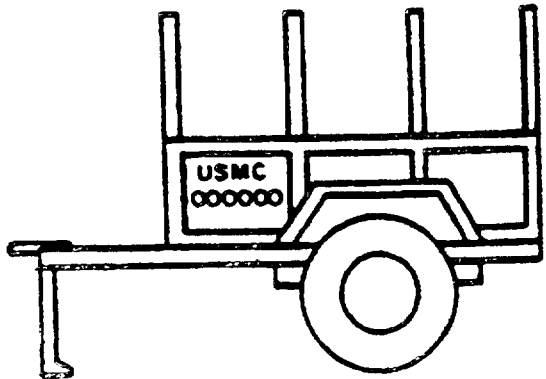

REAR

FIGURE 8. Towed vehicles - Continued.

MTI-STD-642L

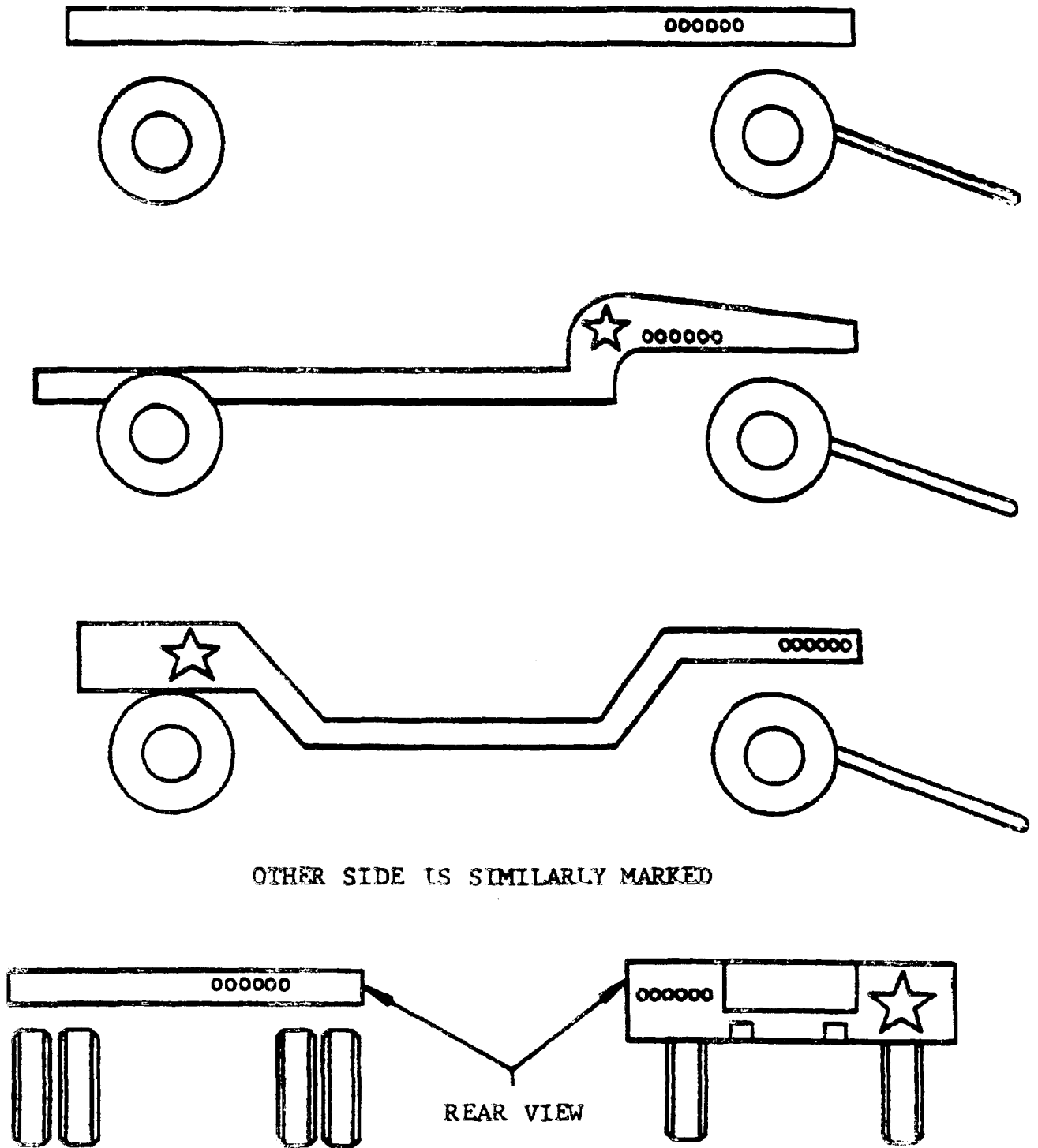

FIGURE 9. Trailers.

MIL-STD-642L

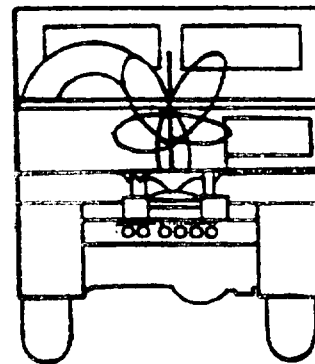
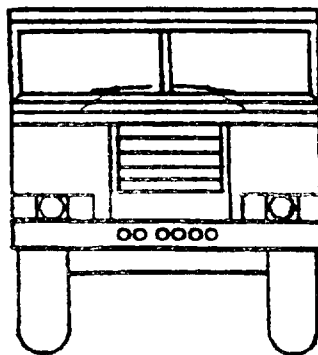
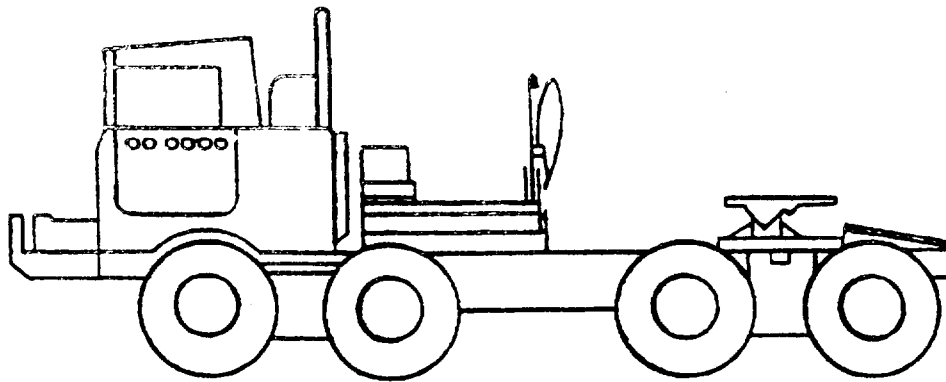

FIGURE 10. Pershing system vehicle (Tractor configuration).

MIL-STD-642L

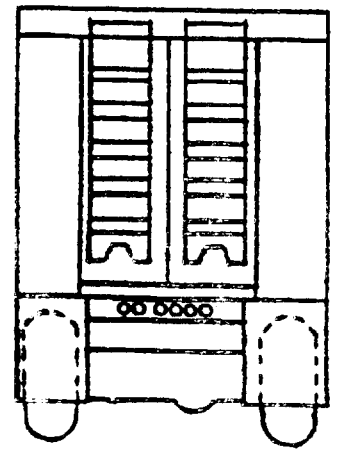
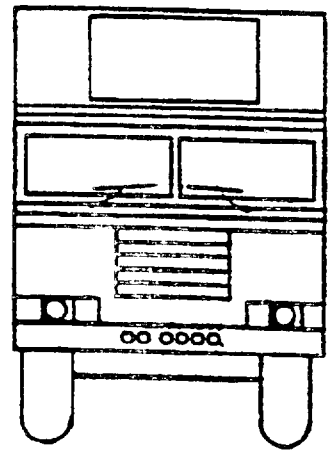
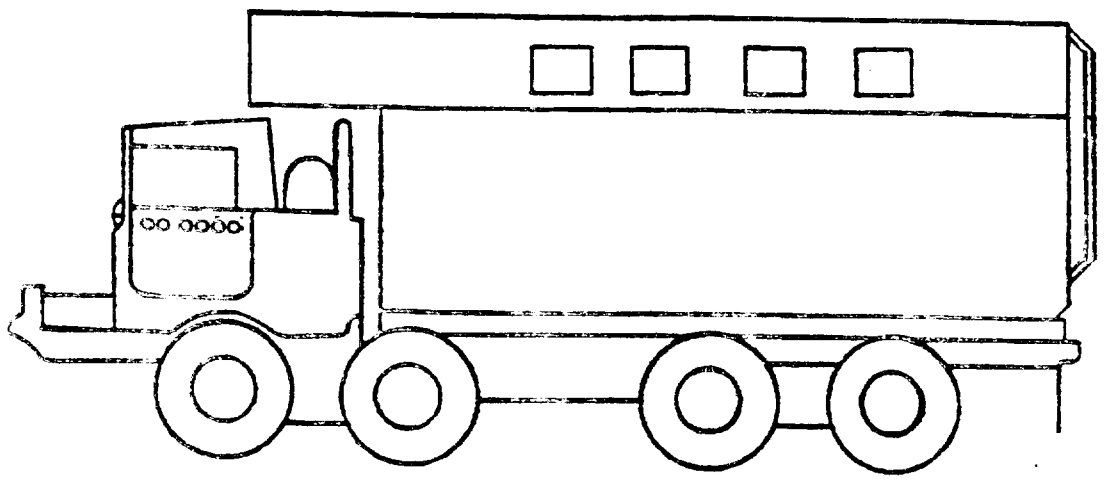

FIGURE 1. Pershing system vehicle (Van configuration)

MIL-STD-642L

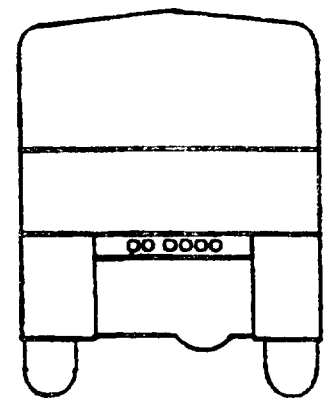
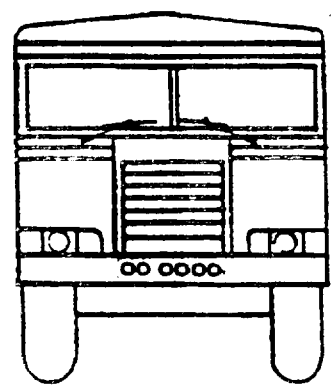
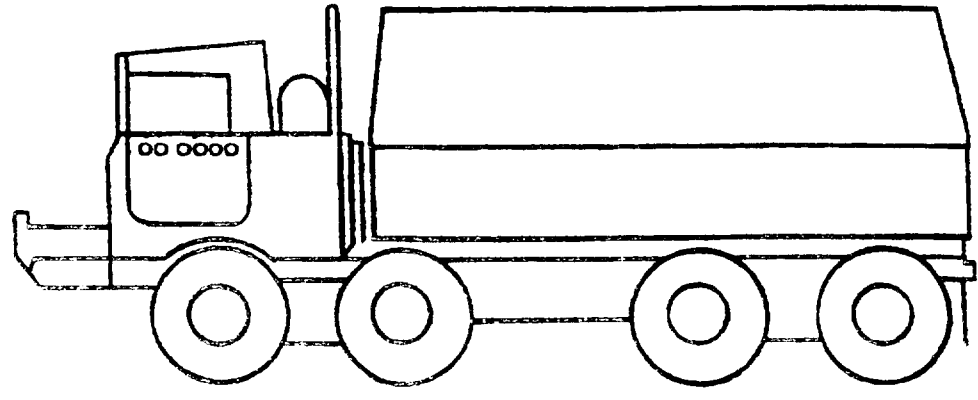

FIGURE 12. Pershing system vehicle (Truck configuration).

MIL-STD-842L

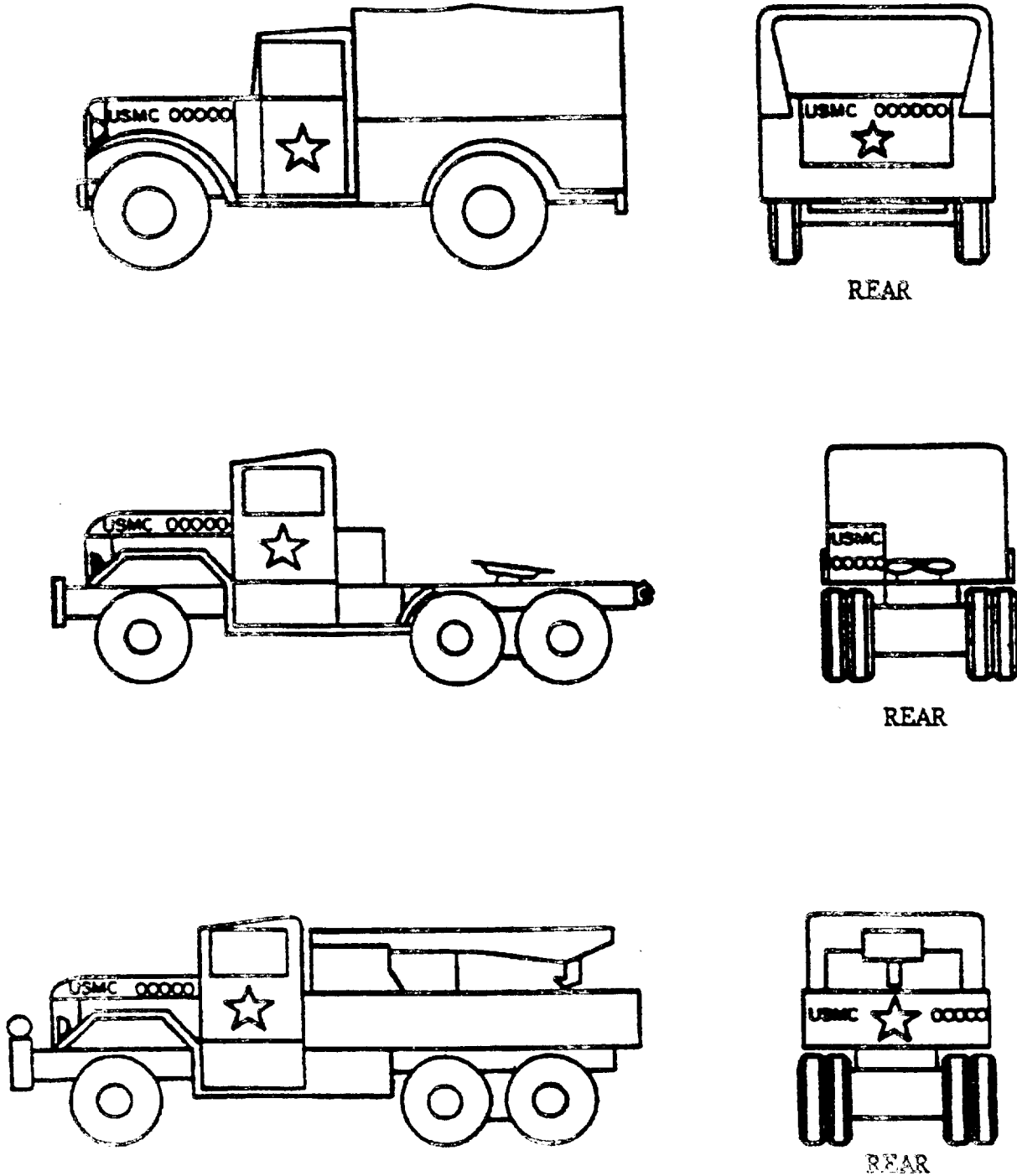

FIGURE 13. Trucks and truck tractors.

MIL-STD-6421.

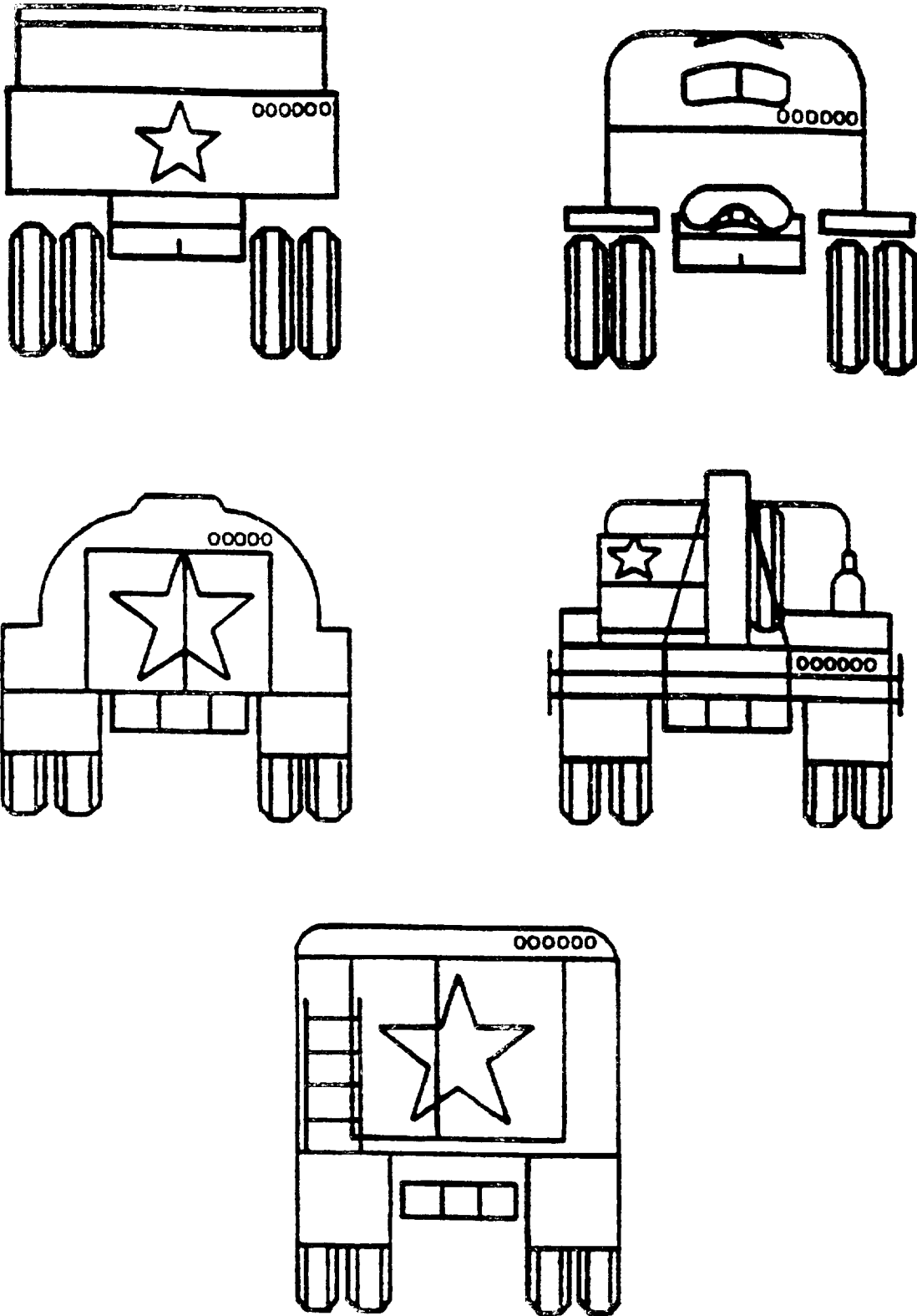
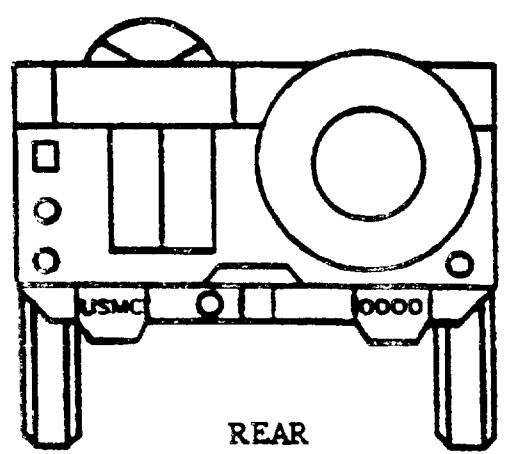
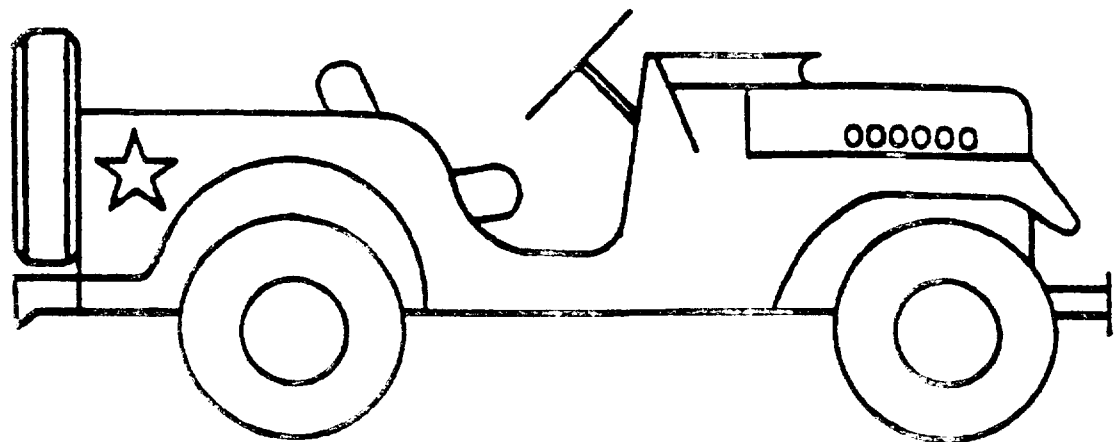

FIGURE 13. Trucks and truck tractors - Continued.

MIL-STD-642L



REAR

FOR USMC ONLY

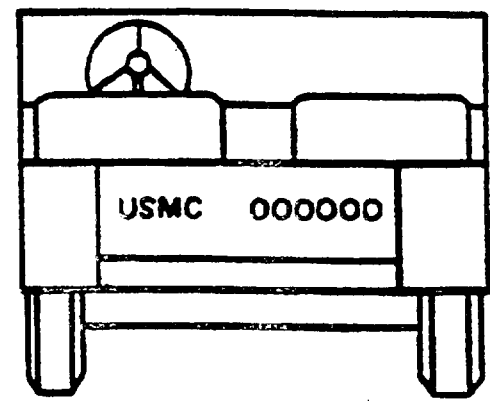

REAR

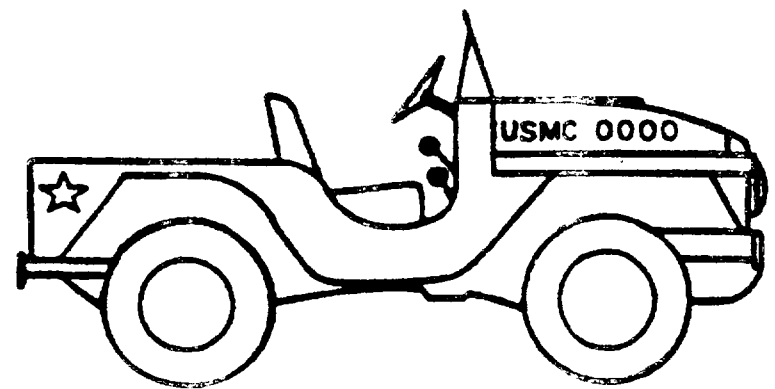
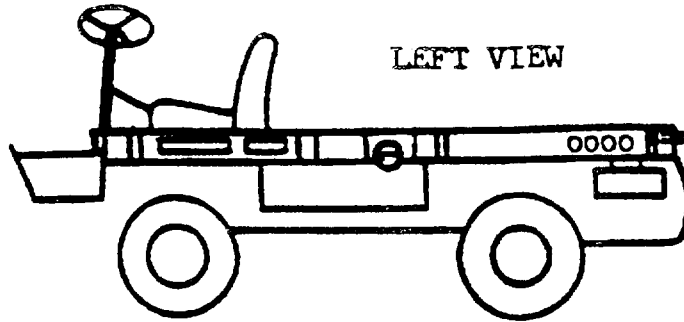
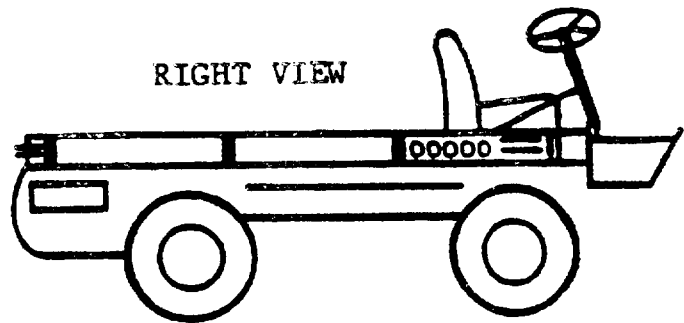

FIGURE 14. Trucks.

MIL-STD-642L



LEFT VIEW



RIGHT VIEW

WEAPONS CARRIER

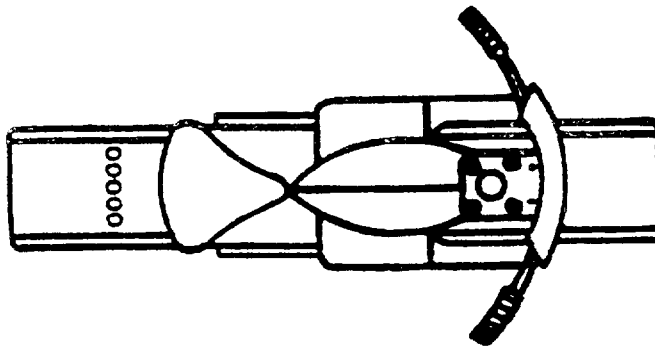

MOTORCYCLE

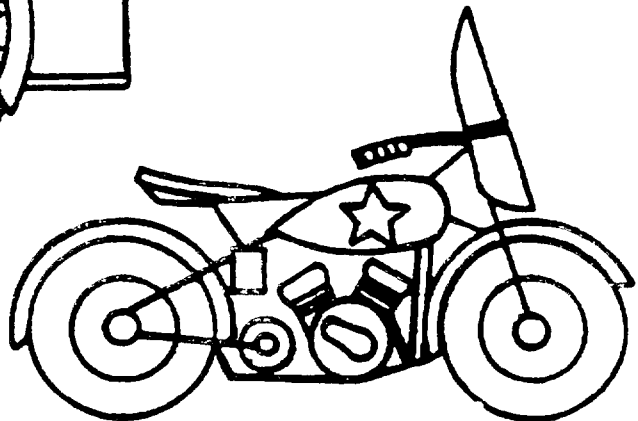

OTHER SIDE IS SIMILARLY MARKED

FIGURE 15. Utility vehicles.

MIL-STD-642L

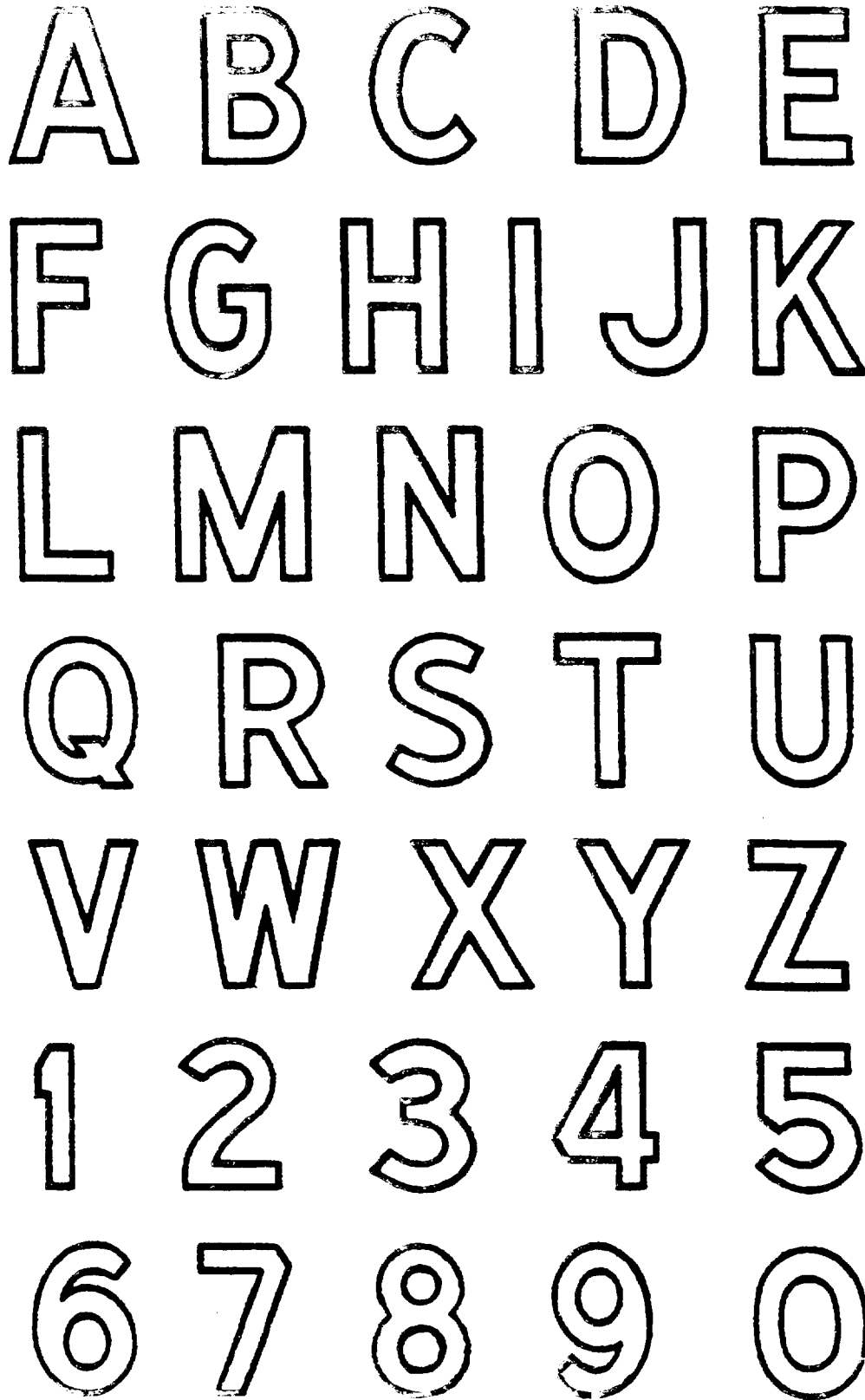

FIGURE 16. Style of marking letters.

MIL-STD-642L

1G 196782

FIGURE 17. Arrangement of U.S. Army marking.

MU.-STD-642L

U S NAVY
93-21960

FIGURE 18. Arrangement of U.S. Navy marking.

MIL-STD-642L

U S AIR FORCE

54B 1960

FIGURE 19. Arrangement of U.S. Air Force marking.

35

U S MARINE CORPS
234568

MIL-STD-6421

FIGURE 20. Arrangement of U.S. Marine Corps marking.

MIL-STD-642L

Custodians:

Army - AT
Navy - YD
Air Force - 99

Preparing activity:

Army - AT

(Project 2320-A447)

Review activities:

Army - MI
Navy - MC

User activities:

Army - MR

FOLD

U.S. ARMY TANK - AUTOMOTIVE COMMAND
ATTN: AMSTA-GDS
WARREN, MICHIGAN 48397-5000

POSTAGE AND FEES PAID



OFFICIAL BUSINESS
PENALTY FOR PRIVATE USE \$300

U.S. ARMY TANK - AUTOMOTIVE COMMAND
ATTN: AMSTA-GDS
WARREN, MICHIGAN 48397-5000

FOLD

STANDARDIZATION DOCUMENT IMPROVEMENT PROPOSAL	
<p>INSTRUCTIONS This form is provided to solicit beneficial comments which may improve this document and enhance its use. DoD contractors, government activities, manufacturers, vendors, or other prospective users of the document are invited to submit comments to the government. Fold on lines on reverse side, staple in corner, and send to preparing activity. Attach any pertinent data which may be of use in improving this document. If there are additional papers, attach to form and place both in an envelope addressed to preparing activity. A response will be provided to the submitter, when name and address is provided, within 30 days indicating that the 1426 was received and when any appropriate action on it will be completed.</p> <p>NOTE: This form shall not be used to submit requests for waivers, deviations or clarification of specification requirements on current contracts. Comments submitted on this form do not constitute or imply authorization to waive any portion of the referenced document(s) or to amend contractual requirements. FSC 2320</p>	
DOCUMENT IDENTIFIER (Number) AND TITLE MIL-STD-642L; Identification Marking of	
Combat and Tactical Transport Vehicles	
NAME OF ORGANIZATION AND ADDRESS OF SUBMITTER	
<input type="checkbox"/> VENDOR <input type="checkbox"/> USER <input type="checkbox"/> MANUFACTURER	
1. <input type="checkbox"/> HAS ANY PART OF THE DOCUMENT CREATED PROBLEMS OR REQUIRED INTERPRETATION IN PROCUREMENT USE? <input type="checkbox"/> IS ANY PART OF IT TOO RIGID, RESTRICTIVE, LOOSE OR AMBIGUOUS? PLEASE EXPLAIN BELOW.	
A. GIVE PARAGRAPH NUMBER AND WORDING	
B. RECOMMENDED WORDING CHANGE	
C. REASON FOR RECOMMENDED CHANGE(S)	
2. REMARKS	
SUBMITTED BY (Printed or typed name and address - Optional)	TELEPHONE NO.
	DATE