

REQUIREMENTS FOR ACQUIRING THE PRODUCT(S) DESCRIBED HEREIN SHALL CONSIST OF THIS SPECIFICATION SHEET AND THE ISSUE OF THE FOLLOWING SPECIFICATION LISTED IN THAT ISSUE OF THE DODISS SPECIFIED IN THE SOLICITATION:

FORM APPROVED  
 OMB NO. 0704-0188

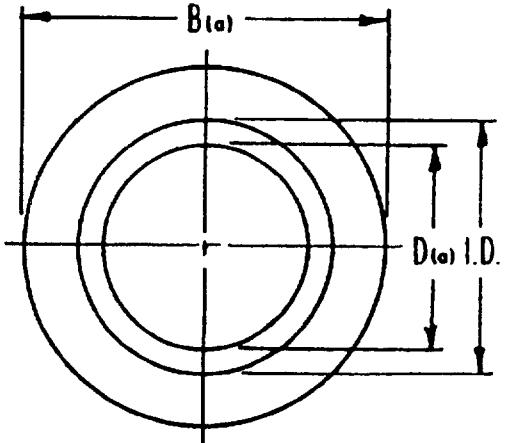

COUNTERSUNK WASHER  
 (FOR USE UNDER BOLT HEAD)

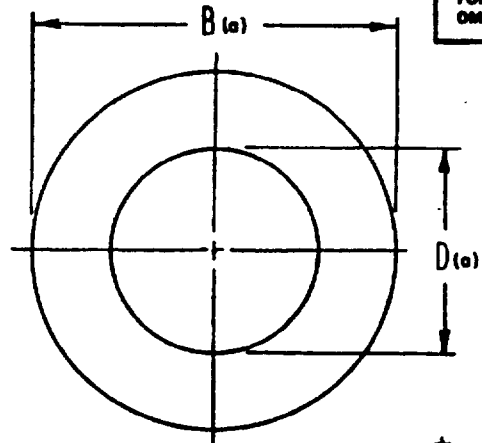

PLAIN WASHER  
 (FOR USE UNDER NUT)

NOMINAL SIZE	DASH NUMBER		$B(a)$		$D(a)$		I. D.		V		FLATNESS MAX	APPROX WEIGHT LB/100
	CSK.	PLAIN	MAX	MIN	MAX	MIN	MAX	MIN	MAX	MIN		
#10	C3	3	.372	.362	.195	.191	.290	.280	.069	.057	.007	.13
1/4	C4	4	.470	.460	.255	.251	.350	.340				.21
5/16	C5	5	.573	.563	.318	.314	.412	.402				.31
3/8	C6	6	.679	.669	.380	.376	.507	.497				.43
7/16	C7	7	.783	.773	.443	.439	.569	.559	.085	.071	.010	.57
1/2	C8	8	.898	.888	.505	.501	.632	.622				.75
9/16	C9	9	1.009	.999	.568	.564	.694	.684				.95
5/8	C10	10	1.125	1.115	.631	.627	.788	.778				1.18
3/4	C12	12	1.350	1.340	.756	.752	.913	.903	.119	.099	.015	1.71
7/8	C14	14	1.572	1.562	.881	.877	1.038	1.028				2.32
1	C16	16	1.798	1.788	1.006	1.002	1.163	1.153				3.04
1 1/8	C18	18	2.188	2.178	1.131	1.127	1.288	1.278				4.81
1 1/4	C20	20	2.260	2.250	1.256	1.252	1.445	1.435	.015	.099	.015	4.84
1 3/8	C22	22	2.490	2.480	1.381	1.377	1.570	1.560				5.89
1 1/2	C24	24	2.723	2.713	1.506	1.502	1.695	1.685				7.06

(a) MINIMUM BEARING AREA BASE ON A BEARING STRESS OF 90 KSI AT THE ULTIMATE TENSILE VALUE OF A 220 KSI BOLT; OR THE FLANGE DIAMETER OF MS21084 NUTS WHICHEVER IS GREATER.

MATERIAL: ALLOY STEEL, MIL-S-6758, MIL-S-18729.

HARDNESS: ROCKWELL C 38-45

SURFACE TEXTURE: 125 MICROINCHES IN ACCORDANCE WITH ANSI B46.1.

PLATING: CADMIUM PLATE, QQ-P-416, TYPE II, CLASS 2.

PARALLELISM: WASHER FACES SHALL BE PARALLEL WITHIN .002 INCHES.

WASHER SHALL BE FREE FROM ALL HANGING BURRS AND SLIVERS WHICH MIGHT BECOME DISLODGED UNDER USAGE.

DIMENSIONS IN INCHES.

DESIGN AND USAGE INFORMATION: THESE WASHERS ARE PRIMARILY FOR USE WITH MS21133 & MS21084 NUTS AND MS21134 AND MS21297 BOLTS.

EXAMPLE OF PART NUMBER: MS21206-3 WASHER, PLAIN, FOR NO. 10 SIZE, 220 KSI BOLT.  
 MS21206-C3 WASHER, COUNTERSUNK, FOR NO. 10 SIZE, 220 KSI BOLT.

FOR DESIGN FEATURE PURPOSES, THIS STANDARD TAKES PRECEDENCE OVER PROCUREMENT DOCUMENTS REFERENCED HEREIN. REFERENCED DOCUMENTS SHALL BE OF THE ISSUE IN EFFECT ON DATE OF INVITATIONS FOR BID.

(A) DENOTES CHANGE

THIS SPECIFICATION IS APPROVED FOR USE BY ALL DEPARTMENTS AND AGENCIES OF THE DEPARTMENT OF DEFENSE.

PREPARING ACTIVITY: NAVY - AS CUSTODIANS: ARMY - AY      NAVY - AIR FORCE - 99      DLA -  REVIEW: AIR FORCE - 82 USER: PROJECT NUMBER: 5310-1785	<b>MILITARY SPECIFICATION SHEET</b>  TITLE WASHER, COUNTERSUNK AND PLAIN, FOR USE WITH BOLTS AND NUTS UP TO AND INCLUDING 220 KSI Ftu	SPECIFICATION SHEET NUMBER <b>MS21206</b> 30 AUG 91 REV A
		SUPERSEDING MS21206      28 JAN 72  AMSC - M/A      FSC 6310

