

**INCH-POUND**

MS21256E  
10 January 2001  
SUPERSEDING  
MS21256D  
20 October 1994

MILITARY SPECIFICATION SHEET

CLIP, LOCKING, TURNBUCKLE

This specification sheet is approved for use by all Departments and Agencies of the Department of Defense.

The requirements for acquiring the product described herein shall consist of this specification sheet and the issue of the following specification listed in that issue of the Department of Defense Index of Specifications and Standards (DoDISS) specified in the solicitation: MIL-DTL-8878, QPL-8878.

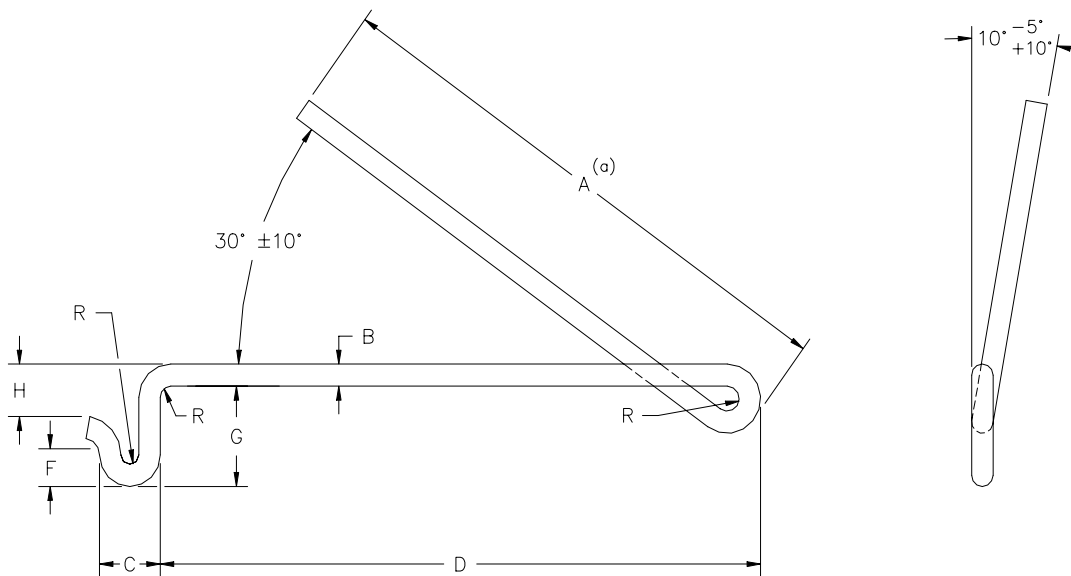

Notes: (a) Dimension A must be held without distortion at end.

FIGURE 1. Clip, locking, turnbuckle.

MS21256E

TABLE I. Dash numbers and dimensions.

Dash number	A <u>1/</u>	ØB ±.0005	C +.010 -.015	D	F	G	H	R radius
-1	.965	.0286	.130	1.075	.125	.300	.165	.032
-2	1.875	.0286		1.955		.315	.180	
-3	2.045	.0286	.215	2.015	.150	.430	.275	

1/ Dimension A must be held without distortion at end.

**REQUIREMENTS:**

1. Dimensions: Dimensions are prior to coating and in inches.
2. Tolerances: Unless otherwise specified, tolerances: decimals ± .015; all internal radii are .032 +.000/-.015.
3. Material: Corrosion resistant steel wire shall be in accordance with ASTM A 313, composition 302 (UNS S30200), condition B.
4. Finish: Finish shall be in accordance with MIL-DTL-8878.
5. Ends: Ends of locking clip shall be cut square and shall be free of burrs.

**NOTES:**

1. Locking clips are for one time use only and shall not be reused or altered. For lock clipping of aircraft turnbuckles, see MS33736.
2. Stock manufactured to the previous revision shall be acceptable for 24 months after the date of this revision.
3. Example of part number: MS21256-1 - clip, turnbuckle, .965 long.
4. In the event of a conflict between the text of this document and the references cited herein, the text of this document takes precedence.

**CHANGES FROM PREVIOUS ISSUE:** Marginal notations are not used in this revision to identify changes with respect to the previous issue due to the extent of the changes.

Custodians:  
 Army - CR4  
 Navy - AS  
 Air Force - 99

Preparing activity:  
 DLA - GS5  
 (Project 1560-0284)