

User activities:
 ARMY-WE
 NAVY-NC

Review activities:
 ARMY-AT, AV, PA, MI
 DLA-TS
 NSA-NS

This military standard is approved for use by all Departments and Agencies of the Department of Defense. Selection for all new engineering and design applications and for repetitive use shall be made from this document, when applicable.

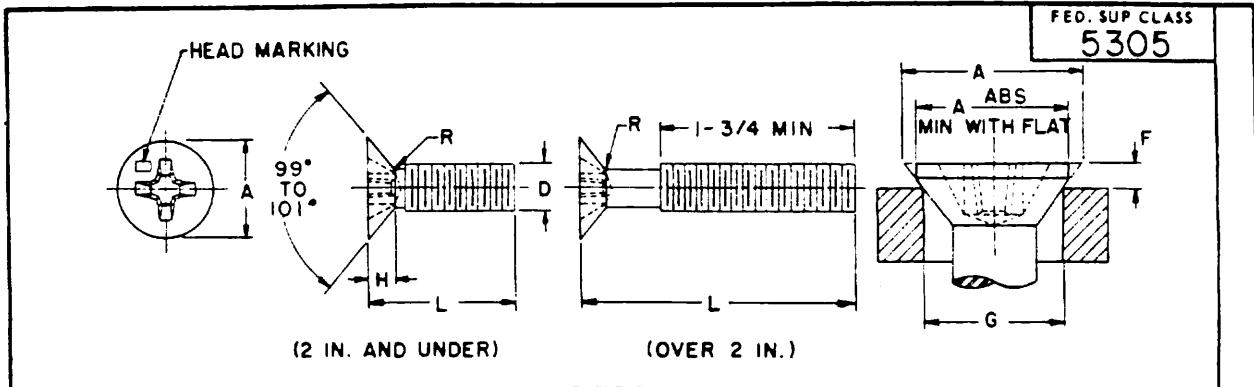

FED. SUP CLASS
5305

TABLE I

NOMINAL SIZE	#0	#2	#4	#6	#8	#10	1/4	5/16	3/8
THREADS PER INCH	80 UNF	56 UNC	40 UNC 48 UNF	32 UNC 40 UNF	32 UNC 36 UNF	24 UNC 32 UNF	20 UNC 28 UNF	18 UNC 24 UNF	16 UNC 24 UNF
D SCREW DIAMETER	BASIC .060	.080	.110	.130	.160	.190	.250	.310	.375
A HEAD DIAMETER	MAX SHARP .119	.172	.225	.279	.332	.385	.507	.635	.742
	MIN SHARP .104	.156	.207	.257	.308	.359	.477	.600	.722
	ABS. MIN .096	.143	.191	.238	.285	.333	.442	.556	.670
F PROTRUSION ABOVE GAGING DIAMETER	MAX .020	.022	.025	.028	.031	.034	.040	.047	.053
	MIN .012	.014	.016	.017	.019	.021	.023	.030	.034
G GAGING DIAMETER	.074	.111	.167	.214	.261	.307	.415	.526	.638
H HEAD HEIGHT	REF .024	.037	.049	.060	.072	.083	.110	.138	.165
R FILLET RADIUS	MAX .007	.008	.015	.015	.020	.020	.020	.025	.030
	MIN .003	.004	.010	.010	.010	.010	.010	.010	.015

REQUIREMENTS:

- MATERIAL:** STEEL, CARBON PER FED-STD-66. ALUMINUM ALLOY PER QQ-A-225/6. BRASS PER QQ-W-321 OR QQ-B-626. COPPER-SILICON ALLOY PER QQ-C-591, ALLOY NO. 651, 655 OR 661. STEEL, CORROSION RESISTING PER FED-STD-66, COMPOSITION 302, 303, 304, 305 OR 316 OR EQUAL TO OR INTERCHANGEABLE WITH 16-18 OR 18-8 CHROMIUM NICKEL ALLOY STEEL (DEVELOPED FOR COLD HEADING). NICKEL COPPER ALLOY PER QQ-N-281, CLASS A.
- PROTECTIVE COATING OR TREATMENT:** BLACK OXIDE COATING IN ACCORDANCE WITH PROCUREMENT SPECIFICATION. ANODIZE IN ACCORDANCE WITH PROCUREMENT SPECIFICATION. BLACK CHEMICAL FINISH IN ACCORDANCE WITH PROCUREMENT SPECIFICATION. CADMIUM PLATED IN ACCORDANCE WITH QQ-P-416, TYPE II, CLASS 3. NICKEL PLATED IN ACCORDANCE WITH QQ-N-290, GRADE E. CLEANING AND DESCALING IN ACCORDANCE WITH ASTM A380-78.
- MAGNETIC PERMEABILITY:** CORROSION RESISTING STEEL SCREWS SHALL HAVE A MAGNETIC PERMEABILITY IN ACCORDANCE WITH PROCUREMENT SPECIFICATION.
- HEAT TREATMENT:** FOR ALUMINUM ALLOY-62KSI MINIMUM ULTIMATE TENSILE STRENGTH PER MIL-H-6088.
- RECESS:** THE RECESS SHALL BE IN ACCORDANCE WITH MS 9006.
- THREADS:** THREADS SHALL BE IN ACCORDANCE WITH FED-STD-H28/2
- THREAD LENGTH:** FOR SCREWS UP TO AND INCLUDING 2 INCHES IN LENGTH, THE COMPLETE THREADS SHALL EXTEND TO WITHIN TWO THREADS OF THE BEARING SURFACE OF THE HEAD, OR CLOSER IF PRACTICABLE. SCREWS OF LONGER LENGTH SHALL HAVE A MINIMUM COMPLETE THREAD LENGTH OF 1 3/4 INCHES.
- UNTHREADED PORTION:** THE DIAMETER OF THE UNTHREADED PORTION OF SCREWS SHALL NOT BE LESS THAN THE MINIMUM PITCH DIAMETER NOR MORE THAN THE MAXIMUM MAJOR DIAMETER OF THE THREAD.
- HEAD MARKING:** MARK CORROSION RESISTING STEEL SCREWS, SIZES #6 AND LARGER, WITH ONE DASH.
- HEADER POINT:** HEADER POINTS IN ACCORDANCE WITH THE PROCUREMENT SPECIFICATION ARE ACCEPTABLE.
- PART NUMBER:** THE MS PART NUMBER CONSISTS OF THE MS NUMBER PLUS THE DASH NUMBER AND CODE. SEE TABLE II AND PAGE 2.

NOTES:

- DIMENSIONS:** ALL DIMENSIONS ARE IN INCHES UNLESS OTHERWISE SPECIFIED.
- REFERENCED DOCUMENTS SHALL BE OF THE ISSUE IN EFFECT ON DATE OF INVITATIONS FOR BIDS, OR REQUEST FOR PROPOSAL EXCEPT THAT REFERENCED ADOPTED INDUSTRY DOCUMENTS SHALL GIVE THE DATE OF THE ISSUE ADOPTED.
- FOR DESIGN FEATURE PURPOSES, THIS STANDARD TAKES PRECEDENCE OVER PROCUREMENT DOCUMENTS REFERENCED HEREIN.

(F) DENOTES CHANGES

P.A. AR OTHER CUST AS 99	TITLE SCREW, MACHINE, FLAT COUNTERSUNK HEAD, 100°, CROSS RECESSED, UNC-2A AND UNF-2A (IN./MM)	MILITARY STANDARD MS24693
PROCUREMENT SPECIFICATION FF-S-92	SUPERSEDES: AN507	PAGE 1 of 4

APPROVED 5 AUG 60 REVISED 25 FEB 82 11 FEB 03

User Activities:
ARMY-AI, AV, EA, MI
DAV-MC
DAV-MC

Review Activities:
ARMY-AI, AV, EA, MI
DAV-MC
DAV-MC

This military standard is approved for use by all Departments and Agencies of the Department of Defense. Selection for all new engineering and design applications and for repetitive use shall be made from this document, when applicable.

		DASH NUMBERS AND CODES **											FED SUP CLASS 5305											
LENGTH		COARSE THREAD							FINE THREAD															
		#2-56	#4-40	#6-32	#8-32	#10-24	#12-20	#16-18	#18-16	#20-16	#24-14	#28-12	#32-10	#36-8	#40-6									
3/32	+0	15											217											
1/8	-1/64	16											218											
5/16		17											219											
3/16			1	23									420	201										
1/4			2	24	46								421	202	224	246	268							
5/16			3	25	47	69	91						422	203	225	247	269							
3/8			4	26	48	70	92						423	204	226	248	270	292						
7/16	+0		5	27	49	71	93						424	205	227	249	271	293						
1	-1/32		6	28	50	72	94	116	135				425	206	228	250	272	294	316	338				
5/8			7	29	51	73	95	117	139				426	207	229	251	273	295	317	339				
3/4			8	30	52	74	96	118	140				427	208	230	252	274	296	318	340				
7/8			9	31	53	75	97	119	141				428	209	231	253	275	297	319	341				
1			10	32	54	76	98	120	142				429	210	232	254	276	298	320	342				
1-1/8			11	33	55	77	99	121	143				430	211	233	255	277	299	321	343				
1-1/4			12	34	56	78	100	122	144				431	212	234	256	278	300	322	344				
1-3/8													432	213	235	257	279	301						
1-1/2	+0		14	36	58	80	102	124	146				433	214	236	258	280	302	324	346				
1-5/8	-1/16												434	215	237	259	281	303						
1-3/4				38	60	82	104	126	148				435	216	238	260	282	304	326	348				
1-7/8													436	217	239	261	283	305						
2				40	62	84	106	128	150				437	218	240	262	284	306	328	350				
2-1/4													438	219	241	263	285	307						
2-1/2	+0			42	64	86	108	130	152				439	220	242	264	286	308	330	352				
2-3/4	-3/32												440	221	243	265	287	309						
3				66	88	110	132	154					441	222	244	266	288	310	332	354				

DASH NUMBER CODE:
 ADD "S" BEFORE DASH NUMBER FOR CADMIUM PLATED, CARBON STEEL SCREW.
 ADD "A" BEFORE DASH NUMBER FOR ANODIZED, ALUMINUM ALLOY SCREW.
 ADD "B" BEFORE DASH NUMBER FOR UNCOATED, BRASS SCREW.
 ADD "BB" BEFORE DASH NUMBER FOR BLACK CHEMICAL FINISH, BRASS SCREW.
 ADD "NS" BEFORE DASH NUMBER FOR NICKEL PLATED, BRASS SCREW.
 ADD "CB" BEFORE DASH NUMBER FOR CADMIUM PLATED, BRASS SCREW.
 ADD "I" BEFORE DASH NUMBER FOR UNCOATED, COPPER SILICON SCREW.
 ADD "C" BEFORE DASH NUMBER FOR CLEANING AND DESCALING, 300 SERIES CORROSION RESISTING STEEL SCREW.
 ADD "N" BEFORE DASH NUMBER FOR UNCOATED, NICKEL COPPER SCREW.
 ADD "E" AFTER DASH NUMBER FOR BLACK OXIDE COATED (MIL-C-13974) CORROSION-RESISTING STEEL SCREW.

EXAMPLES OF MS PART NUMBERS:
 MS24693-S2-A-40UNC-2A, CADMIUM PLATED, CARBON STEEL SCREW, 1/4 INCH LONG.
 MS24693-A2-B-#6-32UNC-2A, ANODIZED, ALUMINUM ALLOY SCREW, 1/2 INCH LONG.
 MS24693-B3-A-#8-32UNC-2A, UNCOATED, BRASS SCREW, 1 INCH LONG.
 MS24693-BB-80-#10-24UNC-2A, BLACK CHEMICAL FINISH, BRASS SCREW, 1-1/2 INCHES LONG.
 MS24693-NB106-1/4-20UNC-2A, NICKEL PLATED, BRASS SCREW, 2 INCHES LONG.
 MS24693-CB132-5/16-18UNC-2A, CADMIUM PLATED, BRASS SCREW, 3 INCHES LONG.
 MS24693-I154-3/8-16UNC-2A, UNCOATED, COPPER SILICON SCREW, 3 INCHES LONG.
 MS24693-C202-#4-48UNC-2A, CLEANING AND DESCALING, 300 SERIES STEEL SCREW, 1/4 INCH LONG.
 MS24693-N254-#8-36UNC-2A, UNCOATED, NICKEL COPPER SCREW, 1 INCH LONG.
 MS24693-206E-#4-48UNC-2A, BLACK OXIDE COATED, CARBON STEEL SCREW, 1/2 INCH LONG.

NOMINAL SIZE	* MINIMUM TENSILE STRENGTH											
	CARBON STEEL		BRASS		ALUMINUM ALLOY		COPPER SILICON ALY		NICKEL COPPER ALY		STEEL CORROSION RESISTING	
	LBS	KN	LBS	KN	LBS	KN	LBS	KN	LBS	KN	LBS	KN
0-80 UNF-2A	105	470	95	420	110	490	105	470	140	620	140	620
2-56 UNC-2A	220	980	220	980	225	1000	220	980	295	1310	295	1310
4-40 UNC-2A	360	1600	330	1470	370	1650	360	1600	480	2140	480	2140
4-48 UNF-2A	400	1780	360	1600	410	1820	400	1780	525	2340	525	2340
6-32 UNC-2A	565	2520	500	2220	560	2490	545	2420	725	3220	725	3220
6-40 UNF-2A	610	2720	560	2490	630	2800	610	2720	810	3600	810	3600
8-32 UNC-2A	840	3740	770	3420	870	3870	840	3740	1120	4980	1120	4980
8-36 UNF-2A	880	3910	810	3600	910	4050	880	3910	1180	5250	1180	5250
10-24 UNC-2A	1050	4660	960	4270	1090	4850	1050	4660	1400	6230	1400	6230
10-32 UNF-2A	1200	5340	1100	4890	1240	5520	1200	5340	1600	7120	1600	7120
1/4-20 UNC-2A	1910	8500	1750	7780	1970	8760	1910	8500	2540	11300	2540	11300
1/4-28 UNF-2A	2180	9700	2000	8900	2250	10000	2180	9700	2910	12940	2910	12940
5/16-18 UNC-2A	3140	13970	2890	12810	3250	14560	3140	13970	4190	18640	4190	18640
5/16-24 UNF-2A	3480	15480	3190	14190	3600	16020	3480	15480	4640	20640	4640	20640
3/8-16 UNC-2A	4790	21280	4400	19600	4800	21300	4790	21280	6200	27560	6200	27560
3/8-24 UNF-2A	5370	23940	4930	21980	5440	24300	5370	23940	7020	31220	7020	31220

*BASED ON 60 KSI MINIMUM ULTIMATE TENSILE STRENGTH FOR CARBON STEEL, 50 KSI FOR BRASS, 62 KSI FOR ALUMINUM ALLOY, 60 KSI FOR COPPER-SILICON ALLOY, 80 KSI FOR NICKEL-COPPER ALLOY AND 67 KSI FOR CORROSION-RESISTING STEEL. LOAD POUNDS ARE CALCULATED BY THE STRESS AREAS INDICATED IN SCREW-THREAD STANDARDS FOR FED-STD-H26. POUNDS HAVE BEEN CONVERTED INTO KILOWATONS (KN) FOR USE WITH THE METRIC SYSTEM.

P.A. OR OTHER CUST. AS 99	TITLE SCREW, MACHINE, FLAT COUNTERSUNK HEAD, 100°, GROSS RECESSED, UNC-2A AND UNF-2A (IN./MM)	MILITARY STANDARD MS24693
PROCUREMENT SPECIFICATION FF-S-92	SUPERSEDES ANSI	PAGE 2 OF 4

APPROVED 5 AUG 60 FOR CHANGES SEE PAGE 2

TABLE IV
INTERCHANGEABILITY - (Using Coded Dash Numbers)

FED. SUP CLASS
5305

After 21 April 1967, screws given on AN507 are canceled, but their existing stock should be used for maintenance purposes until depleted. USE ONLY THE NEW MS24693 SCREWS FOR NEW DESIGN AND ENGINEERING.

Codes for canceled and new dash numbers:

- (1) For cadmium plated, carbon steel screws: The following AN dash numbers are superseded by the following MS dash numbers with a prefix "S" added. Example: AN507-420R5 superseded by MS24693-S91.
- (2) For plain brass screws: AN dash numbers with a prefix "UB" superseded by MS dash numbers with a prefix "B". Example: AN507UB420R5 superseded by MS24693-B91.
- (3) For black chemical finish brass screws: AN dash numbers with a prefix "B" superseded by MS dash numbers with a prefix "BB". Example: AN507B420R5 superseded by MS24693-BB91.
- (4) For cadmium plated, brass screws: AN dash numbers with a prefix "PB" superseded by MS dash numbers with a prefix "CB". Example: AN507PB420R5 superseded by MS24693-CB91.
- (5) For passivated, corrosion resisting steel screws: AN dash numbers with a prefix "C" superseded by MS dash numbers with a prefix "C" Example: AN507C420R5 superseded by MS24693-C91.
- (6) For anodized, aluminum alloy screws: AN dash numbers with a prefix "DD" superseded by MS dash numbers with a prefix "A". Example: AN507DD420R5 superseded by MS24693-A91.
- (7) For AN507 part numbers inactive for design after 17 February 1959: Optional design II cross recessed ("R" between first and second dash numbers) and slotted head screws ("- " between first and second dash numbers) are canceled and superseded by the appropriately coded MS dash number. Example: AN507-420R5 or AN507-420-5 superseded by MS24693-S91.

User Activities:
ARMY-AL
NAVY-MC, SH
NSA-NS

Review activities:
ARMY-AT, AV, EA, MI
DLA-LS
NSA-NS

CANCELED AN507 DASH NUMBERS	NEW MS24693 DASH NUMBERS	CANCELED AN507 DASH NUMBERS	NEW MS24693 DASH NUMBERS	CANCELED AN507 DASH NUMBERS	NEW MS24693 DASH NUMBERS	CANCELED AN507 DASH NUMBERS	NEW MS24693 DASH NUMBERS
420R5	91	445R14	209	624R4E	354	636R7	249
420R6	92	445R16	210	632R3	23	636R5	250
420R7	93	445R18	211	632R4	24	636R10	251
420R8	94	445R20	212	632R5	25	636R12	252
420R10	95	445R22	213	632R6	26	636R14	253
420R12	96	445R24	214	632R7	27	636R16	254
420R14	97	445R26	215	632R8	28	636R18	255
420R16	98	445R28	216	632R10	29	636R20	256
420R18	99	515R5	116	632R12	30	636R22	257
420R20	100	515R10	117	632R14	31	636R24	258
420R24	102	515R12	118	632R16	32	636R26	259
420R25	104	515R14	119	632R18	33	636R28	260
420R32	106	515R16	120	632R20	34	636R30	261
420R40	108	515R18	121	632R24	36	636R32	262
420R45	110	515R20	122	632R25	38	636R36	263
425R6	292	515R24	124	632R32	40	636R40	264
425R7	293	515R28	126	632R40	42	636R44	265
425R8	294	515R32	128	640R4	224	636R45	266
425R10	295	515R40	130	640R5	225	1024R5	69
425R12	296	515R45	132	640R6	226	1024R6	70
425R14	297	524R5	316	640R7	227	1024R7	71
425R16	298	524R10	317	640R8	228	1024R8	72
425R15	299	524R12	318	640R10	229	1024R10	73
425R20	300	524R14	319	640R12	230	1024R12	74
425R22	301	524R16	320	640R14	231	1024R14	75
425R24	302	524R18	321	640R16	232	1024R16	76
425R26	303	524R20	322	640R18	233	1024R18	77
425R25	304	524R24	324	640R20	234	1024R20	78
425R30	305	524R26	326	640R22	235	1024R24	80
425R32	306	524R32	328	640R24	236	1024R25	82
425R36	307	524R40	330	640R26	237	1024R32	84
425R40	308	524R45	332	640R28	238	1024R40	86
425R44	309	616R5	135	640R30	239	1024R45	88
425R48	310	616R10	139	640R32	240	1032R4	265
440R3	1	616R12	140	640R36	241	1032R5	269
440R4	2	616R14	141	640R40	242	1032R6	270
440R5	3	616R16	142	832R4	46	1032R7	271
440R6	4	616R18	143	832R5	47	1032R8	272
440R7	5	616R20	144	832R6	48	1032R10	273
440R8	6	616R24	146	832R7	49	1032R12	274
440R10	7	616R25	148	832R8	50	1032R14	275
440R12	8	616R32	150	832R10	51	1032R16	276
440R14	9	616R40	152	832R12	52	1032R18	277
440R16	10	616R45	154	832R14	53	1032R20	278
440R15	11	624R5	335	832R16	54	1032R22	279
440R20	12	624R10	339	832R18	55	1032R24	280
440R24	14	624R12	340	832R20	56	1032R26	281
445R3	201	624R14	341	832R24	58	1032R28	282
445R4	202	624R16	342	832R25	60	1032R30	283
445R5	203	624R15	343	832R32	62	1032R32	284
445R6	204	624R20	344	832R40	64	1032R36	285
445R7	205	624R24	346	832R45	66	1032R40	286
445R8	206	624R26	348	836R4	246	1032R44	287
445R10	207	624R32	350	836R5	247	1032R45	288
445R12	208	624R40	352	836R6	248		

This military standard is approved for use by all Departments and Agencies of the Department of Defense. Selection for all new engineering and design application and for repetitive use shall be made from this document, where applicable.

APPROVED 5 AUG 60 FOR CHANGES SEE PAGE 2

P.A. AR	TITLE	MILITARY STANDARD
OTHER CUST AS 99	SCREW, MACHINE, FLAT COUNTERSUNK HEAD, 100°, CROSS RECESSED, UNC-2A AND UNF-2A (IN./MM)	MS24693
PROCUREMENT SPECIFICATION FF-S-92	SUPERSEDES: AN507	PAGE 3 OF 4

User activities:
 ARMY-NE
 NAVY-MC, SH
 Review activities:
 ARMY-AT, AV, EA, MI,
 DIA-IS
 NSA-NS

This military standard is approved for use by all Departments and Agencies of the Department of Defense. Selection for all new engineering and design applications and for repetitive use shall be made from this document, when applicable.

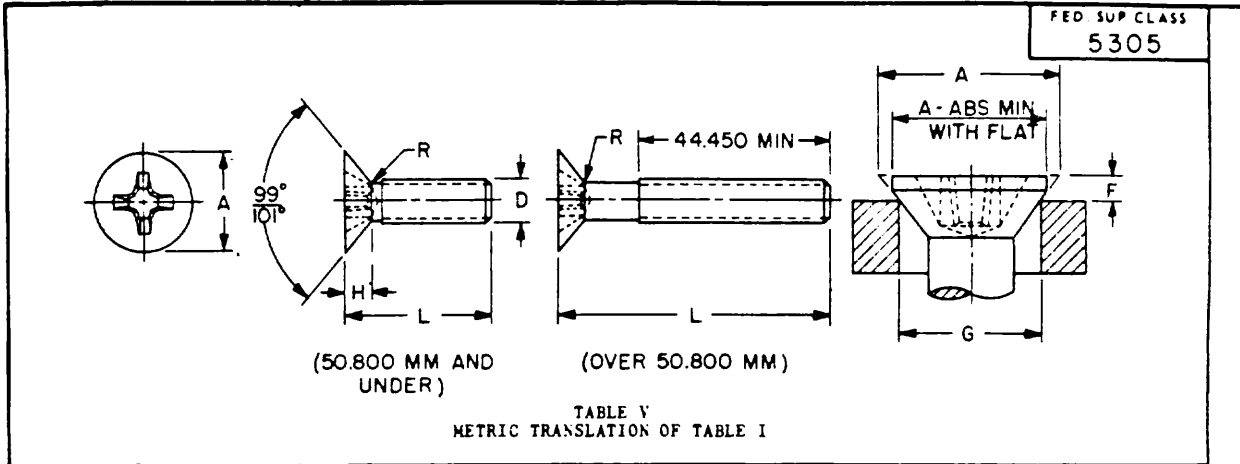

FED SUP CLASS
5305

TABLE V
 METRIC TRANSLATION OF TABLE I

NOMINAL SIZE	INCH MM	#4 2.645	#6 3.505	#8 4.166	#10 4.826	1/4 6.350	5/16 7.938	3/8 9.525	
THREADS PER 25.4 MM		40 UNC 48 UNF	32 UNC 40 UNF	32 UNC 36 UNF	24 UNC 32 UNF	20 UNC 28 UNF	18 UNC 24 UNF	16 UNC 24 UNF	
D SCREW DIAMETER	BASIC	2.645	3.505	4.166	4.826	6.350	7.938	9.525	
A HEAD DIAMETER	MAX SHARP MIN SHARP ABS MIN	5.715 5.258 4.851	7.087 6.528 6.045	8.433 7.823 7.239	9.779 9.119 8.458	12.875 12.116 11.227	16.129 15.240 14.122	19.355 18.339 17.016	
F PROTRUSION ABOVE GAGING DIAMETER	MAX MIN	.635 .406	.711 .432	.787 .483	.864 .533	1.016 .635	1.194 .762	1.346 .864	
G GAGING DIAMETER		4.242	5.436	6.629	7.798	10.541	13.360	16.205	
H HEAD HEIGHT	REF	1.245	1.524	1.829	2.108	2.794	3.505	4.191	
R FILLET RADIUS	MAX MIN	.381 .254	.381 .254	.508 .254	.508 .254	.508 .254	.635 .254	.762 .381	
L LENGTH	TOLERANCE	DASH NO.		DASH NO.		DASH NO.		DASH NO.	
4.762 6.350 7.938 9.525 11.112	+0 -.757	1 201 2 202 3 203 4 204 5 205	23 24 224 25 225 26 226 27 227	46 246 47 247 48 248 49 249	69 269 70 270 71 271	91 92 292 93 293			
12.700 15.875 19.050 22.225 25.400		6 206 7 207 8 208 9 209 10 210	28 228 29 229 30 230 31 231 32 232	50 250 51 251 52 252 53 253 54 254	72 272 73 273 74 274 75 275 76 276	94 294 95 295 96 296 97 297 98 298	116 316 117 317 118 318 119 319 120 320	138 338 139 339 140 340 141 341 142 342	160 360 161 361 162 362 163 363 164 364
26.575 31.750 34.925 38.100	+0 -1.575	11 211 12 212 13 213 14 214	33 233 34 234 35 235 36 236	55 255 56 256 57 257 58 258	77 277 78 278 79 279 80 280	99 299 100 300 101 301 102 302	121 321 122 322 123 323 124 324	143 343 144 344 145 345 146 346	165 365 166 366 167 367 168 368
41.275 44.450 47.625 50.800			215 237 216 238 38 239 40 240	59 259 60 260 61 261 62 262	81 281 82 282 83 283 84 284	103 303 104 304 105 305 106 306	125 325 126 326 127 327 128 328	147 347 148 348 149 349 150 350	169 369 170 370 171 371 172 372
57.150 63.500 69.850 76.200	+0 -2.362		42 241 242	63 263 64 264 65 265 66 266	85 285 86 286 87 287 88 288	107 307 108 308 109 309 110 310	129 329 130 330 131 331 132 332	151 351 152 352 153 353 154 354	173 373 174 374 175 375 176 376

- NOTES:
 1. All dimensions are in millimeters (MM), unless otherwise specified.
 2. For dash number code (material and protective coating) see PAGE 2.
 3. For minimum tensile strength values, see PAGE 2.

APPROVED 5 AUG 1960

P.A. AR OTHER CUST AS 99	TITLE SCREW, MACHINE, FLAT COUNTERSUNK HEAD, 100°, CROSS RECESSED, UNC-2A AND UNF-2A (IN./MM)	MILITARY STANDARD MS 24693
PROCUREMENT SPECIFICATION FF-S-92	SUPERSEDES AN507	PAGE 4 OF 4