

REPORT 1177

COMPARISON OF PERFORMANCE OF EXPERIMENTAL AND CONVENTIONAL CAGE DESIGNS AND MATERIALS FOR 75-MILLIMETER-BORE CYLINDRICAL ROLLER BEARINGS AT HIGH SPEEDS ¹

By WILLIAM J. ANDERSON, E. FRED MACKS, and ZOLTON N. NEMETH

SUMMARY

The results of two investigations, one to determine the relative merits of four experimental and two conventional design 75-millimeter-bore (size 215) cylindrical roller bearings and one to determine the relative merits of nodular iron and bronze as cage materials for this size and type of bearing, are reported herein. Nine test bearings were operated over a range of DN values (product of bearing bore in mm and shaft speed in rpm) from 0.3×10^6 to 2.3×10^6 , radial loads from 7 to 1613 pounds, and oil flows from 2 to 8 pounds per minute with a single-jet circulatory oil feed.

Of the six bearings used to evaluate designs, four were experimental types with outer-race-riding cages and inner-race-guided rollers, and two were conventional types, one with outer-race-guided rollers and cage and one with inner-race-guided rollers and cage. Each of these six test bearings was equipped with a different design cage made of nodular iron.

The experimental combination of an outer-race-riding cage with a straight-through outer race and inner-race-guided rollers was found to give the best over-all performance based on limiting DN values and bearing temperatures. The better performance of this type bearing over both the conventional inner-race-riding cage type and the conventional outer-race-riding cage type with outer-race-guided rollers is a result of the relative ease of lubrication and cooling and of the adequate oil exiting paths which minimize oil entrapment and churning losses.

The conventional inner-race-riding cage-type bearing could not be successfully operated at DN values above 1.72×10^6 because it is inherently difficult to lubricate and cool. For the same reason, the operating temperatures of this type bearing were higher than those of the four experimental bearings throughout the range of speed and oil flow investigated.

The conventional outer-race-riding cage-type bearing with outer-race-guided rollers operated successfully at a DN value of 2.1×10^6 but incurred very severe cage and roller wear at very high speeds, probably because of high cage slip. This type bearing was found to be adequately lubricated and cooled at relatively low oil flows (2.0 and 2.75 lb/min). At oil flows of 5.5 and 8.0 pounds per minute, however, this type bearing operated at higher temperatures than the other test bearings because of excessive churning losses.

Cage-pocket type (broached or fitted) had little or no effect on bearing operating temperature or heat dissipation to the oil. Both cages with fitted pockets incurred greater wear in the roller pockets than did their prototypes with broached pockets.

Four identical bearings with outer-race-guided rollers and cages (two with nodular iron and two with bronze cages) were used to evaluate the two cage materials. The results, which are applicable with certainty only to the outer-race-riding cage-type bearing, indicate that wear rates vary with cage slip and appear to be a function of cage material and also of the sliding velocity and load between the rollers and inner race. Cage slip occurs more readily at DN values above 1.2×10^6 if the cage material is nodular iron rather than the bronze investigated. Consequently, bearings with nodular iron cages showed more wear of rollers and cages (especially in cage-roller pockets) than did bearings with bronze cages.

The severe roller and cage wear obtained in the two conventional outer-race-riding cage-type bearings with nodular iron cages suggests that roller-pocket and cage-locating-surface friction may, under certain operating conditions, exceed the tractive force between the rollers and inner race and may, therefore, be responsible for the onset of cage slip. Cage slip in bearings with bronze cages was accompanied by severe roller wear and light cage wear in the cage-roller pockets. This fact, together with the severe cage wear associated with nodular iron cage-type-bearing slip, suggests that cage material may be a factor in reducing cage wear in a bearing operating under slip conditions.

There was little difference in performance between the bronze and nodular iron cages as measured by bearing temperature, heat dissipation to the oil, and bearing wear at DN values to 1.2×10^6 (16,000 rpm). The wear in all test bearings at speeds to 16,000 rpm was light and was not of a magnitude that would indicate a very limited life.

INTRODUCTION

The investigation reported herein was conducted at the NACA Lewis laboratory during 1952 and 1953.

Although cage failures rank high among the causes of bearing failure in high-speed roller and ball bearings in turbojet and turboprop engines (refs. 1 to 6), little research has been reported on either cage materials or cage designs. Basic friction and wear studies of cage materials are reported in references 7 to 9.

It would be ideal to design a cage with hydrodynamic lubrication at all points of contact between the cage and races and rollers, for then failures due to wear, galling, and cage pickup would not exist. This mode of lubrication has been the object of preliminary NACA research on cage designs,

¹ Supersedes NACA TN 3001, "Comparison of Operating Characteristics of Four Experimental and Two Conventional 75-Millimeter-Bore Cylindrical-Roller Bearings at High Speeds," by William J. Anderson, E. Fred Macks, and Zolton N. Nemeth, 1953, and TN 3002, "Effect of Bronze and Nodular Iron Cage Materials on Cage Slip and Other Performance Characteristics of 75-Millimeter-Bore Cylindrical-Roller Bearings at DN Values to 2×10^6 ," by William J. Anderson, E. Fred Macks, and Zolton N. Nemeth, 1953.

but success has not yet been achieved in this regard. Until hydrodynamic lubrication at all cage-contacting surfaces can be achieved, boundary lubrication will exist at points of sliding contact, and the wear and frictional properties of the cage material will be of extreme importance. In addition, oil interruption requirements are becoming exceedingly severe. For a bearing to operate 15 minutes without oil supply, as is recommended in a recent military specification, auxiliary lubrication systems must be employed to achieve hydrodynamic lubrication. The oil interruption requirement therefore serves to emphasize the cage material problem.

Much work remains to be done on the evaluation of the merits of the more promising cage materials in actual bearings. Data obtained with friction and wear machines merely act as a guide in the choice of materials from which cages should be made, and results cannot be considered conclusive until bearing performance data are at hand.

The evaluation of the relative merits of various cage designs must be considered along with the materials problem. Some of the present cage designs are not satisfactory because they incorporate many inaccessible surfaces making adequate lubrication difficult or impossible. The inner-race-riding cage type, which is perhaps used more widely than any other, has given fairly good results notwithstanding the fact that lubrication of the cage-locating surface is very difficult, since centrifugal force tends to throw the oil away from this surface (ref. 6). There is not much published information on the performance characteristics of outer-race-riding cages. Cages of this type are believed to trap oil, create high churning losses, and thus operate at higher temperatures than do other types of cages. However, such churning losses are due primarily to design and are not necessarily characteristic of this cage type. Furthermore, it appears that a properly designed outer-race-riding cage might prove to be inherently better than other types of cages.

The experimental results reported herein consist of two comparisons: one of cage designs and one of cage materials. All test bearings were 75-millimeter-bore (size 215) cylindrical roller bearings. The operating characteristics of six bearings equipped with nodular iron cages of different design were determined at DN values (bore in mm times shaft speed in rpm) of 0.3×10^6 to 2.3×10^6 , loads of 7 to 1613 pounds, and oil flows of 2 to 8 pounds per minute. The materials evaluation consisted of a determination of the operating characteristics of four bearings which were identical except for cage material, two being equipped with bronze and two with nodular iron cages, at DN values of 0.3×10^6 to 2.1×10^6 , loads of 7 to 1613 pounds, and oil flows of 2 to 8 pounds per minute. Test bearings are compared with respect to operating temperatures, limiting DN values, wear, and heat dissipation to the oil. The test bearings are described fully in the section **TEST BEARINGS**.

APPARATUS

BEARING RIG

The bearing rig (fig. 1) used for this investigation is basically the same as that used in references 10 and 11. Prior to

running the tests reported herein, the rig itself was connected to a new gearbox and drive motor. In addition, a dashpot was added to the load arm to dampen vibrations of the arm at high speeds.

As shown in figure 1, the bearing under investigation was mounted on one end of the test shaft, which was supported in cantilever fashion in order that bearing component parts and lubricant flow could be observed during operation. A radial load was applied to the test bearing by means of a lever and dead-weight system in such a manner that the loading of the test bearing was essentially unaffected by small shaft deflections or by small shaft and load-arm misalignments.

The support bearings were lubricated in the manner described in reference 10. Oil was supplied to the support bearings at a pressure of 10 pounds per square inch through 0.180-inch-diameter jets and at a temperature equal to that of the test-bearing oil (100° F).

DRIVE EQUIPMENT

The high-speed drive equipment consisted of a shunt-wound 30-horsepower direct-current motor connected to a 14:1 speed increaser. The high-speed shaft of the speed increaser was connected to the test shaft by means of a floating spline coupling. The speed range of the test shaft was 1100 to 36,000 rpm, controllable to within ± 50 rpm at all speeds.

TEMPERATURE MEASUREMENT

The method of temperature measurement is described in reference 10. Iron-constantan thermocouples were located in the outer-race housing at 60° intervals around the outer-race periphery at the axial midpoint of the bearing under investigation. A copper-constantan thermocouple was pressed against the bore of the inner race at the axial midpoint of the test bearing. The thermocouple electromotive force was transmitted from the rotating shaft by means of small slip rings located on the end of the test shaft (ref. 12).

LUBRICATION SYSTEM

The lubrication system used was of the circulating type. Separate pumps were used to supply oil to the support bearings and the test bearing, and full-flow filters were provided after the oil-supply pumps. Oil inlet temperature was controlled to within $\pm 1^\circ$ F and oil inlet pressure to within ± 0.5 pound per square inch. Support-bearing oil flow was drained by gravity from the base of the rig. Test-bearing oil was collected in cans and pumped either to weighing buckets or back to the sump.

TEST BEARINGS

Nine test bearings (size 215) were used for the investigations. Bearing dimensions were: bore, 75 millimeters; outside diameter, 130 millimeters; and width, 25 millimeters. All bearings had standard SAE 52100 steel races and rollers of the same surface finish and hardness (within manufacturing tolerances). Schematic drawings of all nine test bearings are

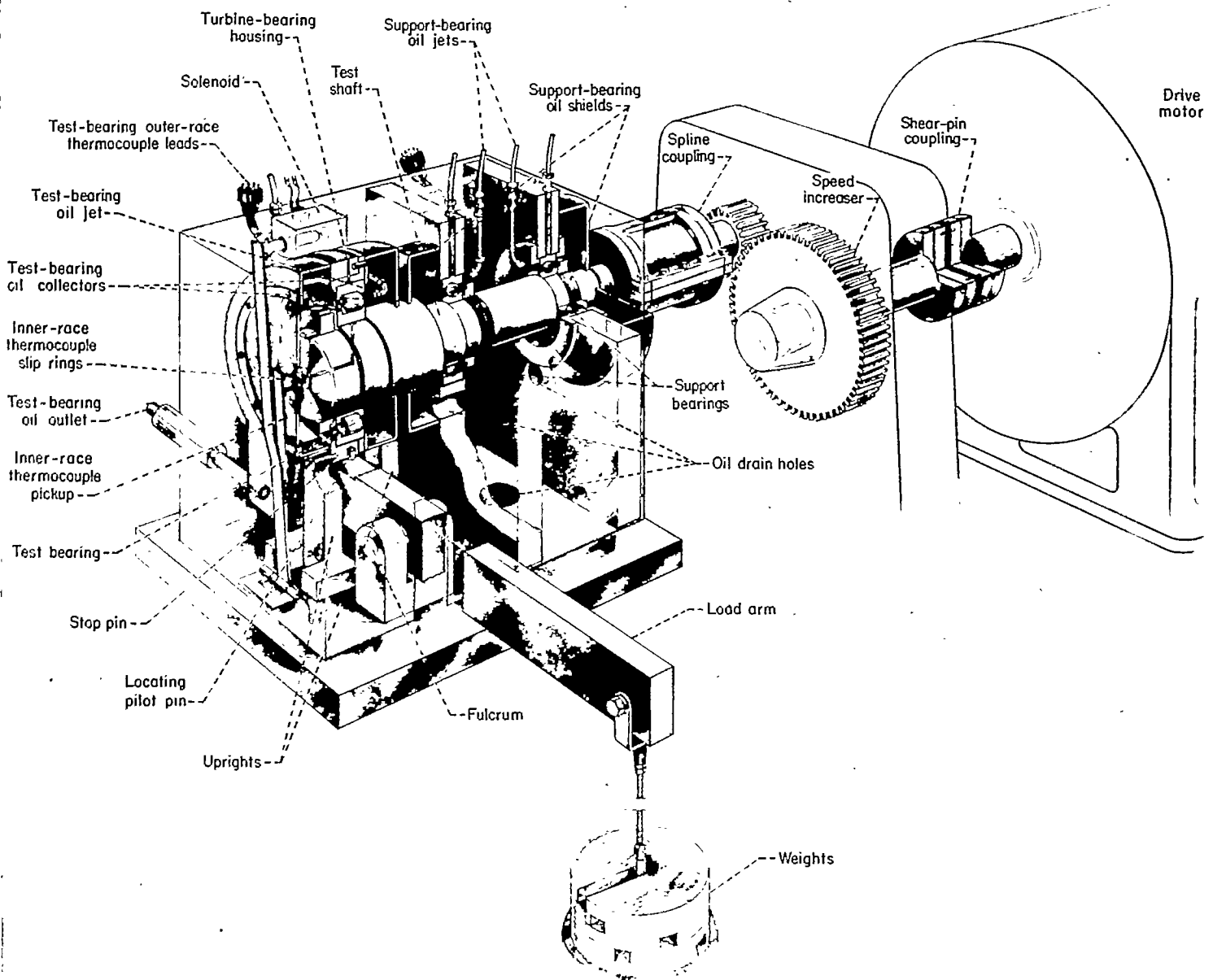

FIGURE 1.—Cutaway view of radial-load rig.

shown in figure 2. Data for bearings A to F were used for the cage-design evaluation, while data for bearings F to I were used for the cage-material evaluation. Bearings A to G were equipped with pearlitic nodular iron cages cut from the same billet, and bearings H and I were equipped with bronze cages. Physical properties and chemical composition of the cage materials are given in table I. Nodular iron was chosen as the first material to be used in this experimental cage-material program because it affords a good combination of antiweld, wear, expansion-coefficient, and strength properties (ref. 7).

Bearings A, B, C, D, and E all had double-flanged inner races (inner-race-guided rollers) and straight-through outer races. Bearings F to I had double-flanged outer races (outer-race-guided rollers) and straight-through inner races. Bearing A was equipped with a one-piece inner-race-riding cage

with 20 broached pockets (fig. 2(a)). Bearing B was equipped with a two-piece cage with 16 fitted pockets which was piloted on the outer race outside the roller track (fig. 2(b)). Bearing C was equipped with a one-piece cage with 16 broached pockets which was piloted on the outer race outside the roller track (fig. 2(c)). Bearing D was equipped with a one-piece cage with 16 broached pockets which was piloted on the outer race in the roller track (fig. 2(d)). Bearing E was equipped with a two-piece cage with 16 fitted pockets which was piloted on the outer race in the roller track (fig. 2(e)). Bearings F to I were equipped with one-piece cages with 20 broached pockets which were piloted on the shoulders of the outer-race flanges (fig. 2(f)).

The dimensions of all nine test bearings are given in table II.

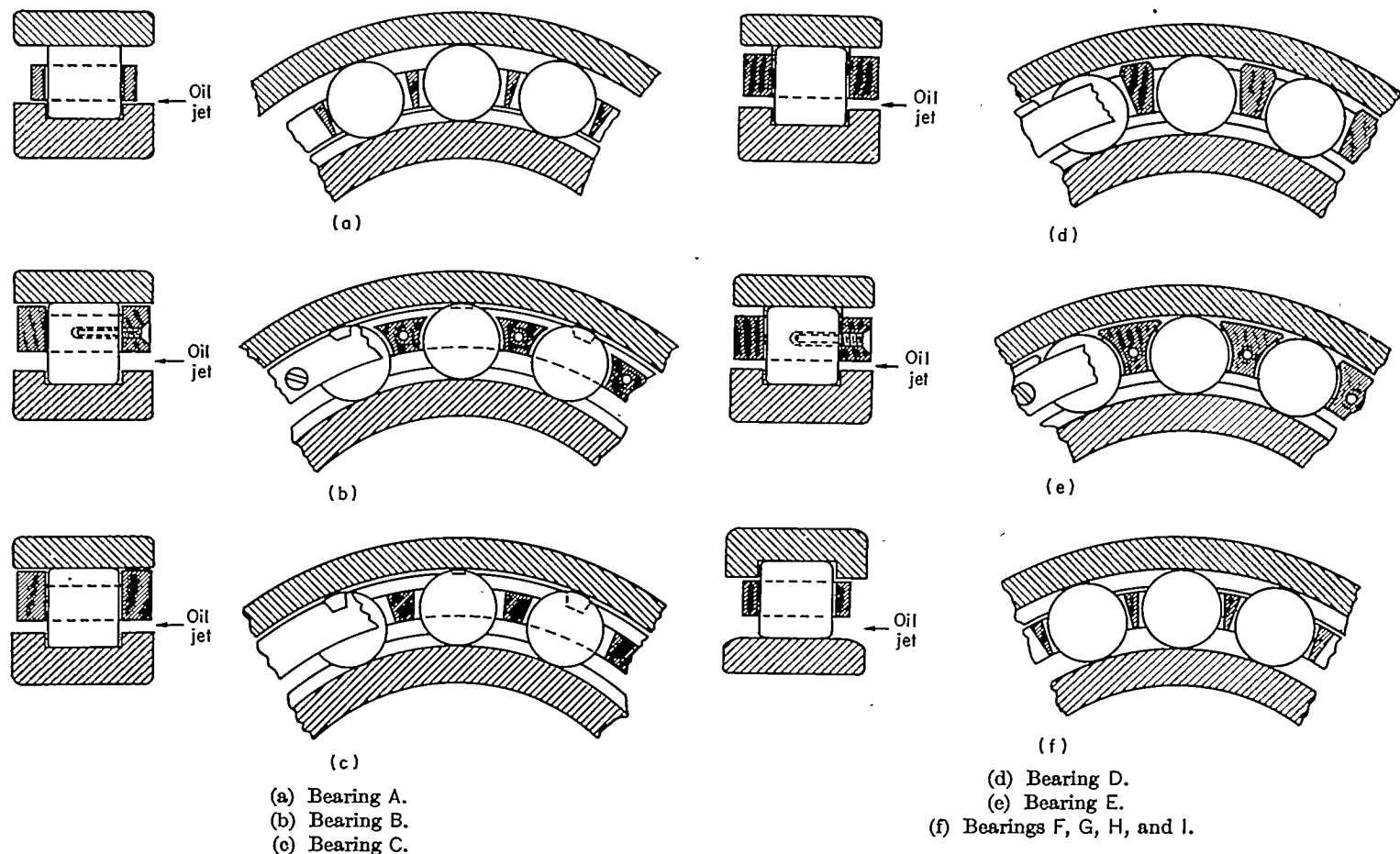

FIGURE 2.—Schematic drawings of test bearings.

PROCEDURE

Each bearing was first subjected to a number of tests at DN values of 0.3×10^6 to 1.2×10^6 , loads of 7 to 1613 pounds, and oil flows of 2 to 8 pounds per minute. (These tests were collectively termed the low-speed tests.) Each bearing was then run to the maximum speed at which equilibrium temperatures could be obtained at oil flows of 2 to 8 pounds per minute. The six bearings used in the cage-design investigation were checked for wear only after the high-speed tests, whereas the four bearings used to evaluate the cage materials were checked for wear after both the low- and high-speed tests. Each bearing was run through the same series of tests so that the total running time on each bearing was approximately equal.

LUBRICATION OF TEST BEARINGS

Lubricant was supplied to the test bearings through a single jet having a 0.050-inch-diameter orifice. The oil was directed normal to the bearing face opposite the load zone. The optimum radial position for the oil jet was determined experimentally for each test bearing and was found to be between the cage and inner race for all test bearings.

A highly refined nonpolymer-containing petroleum-base lubricating oil used to lubricate the bearings in several current turbojet engines was used to lubricate the test bearings. The viscometric properties of the test oil are shown in figure 3. Data for figure 3 were obtained from daily samples of test oil. Viscosities were obtained by standard laboratory

procedures, and the data plotted in figure 3 represent the mean for all the samples of oil.

Oil was supplied to the test bearings at a temperature of 100° F and at pressures of 30 to 405 pounds per square inch, which corresponded to oil flows of 2 to 8 pounds per minute.

TEST-BEARING MEASUREMENTS

Measurements of test-bearing component parts were obtained in a constant-temperature gage room. Standard, precision inspection instruments measuring to 0.0001 inch per division were used to obtain dimensions of the races and cages. A comparator-type gage measuring to 2×10^{-6} inch was used to obtain roller measurements. Test-bearing-hardness measurements are given in table III, and test-bearing surface-finish measurements are given in table IV.

RESULTS AND DISCUSSION

The results of the experimental investigation of cage designs are presented in figures 4 to 10 and tables II to IV. The results of the experimental investigation of cage materials are presented in figures 11 to 15 and in tables II to VI. Bearing performance is discussed and analyzed with respect to bearing temperature, heat dissipation to the oil, bearing wear, and limiting DN value. The latter is defined as the maximum DN at which the bearing will operate at an equilibrium temperature.

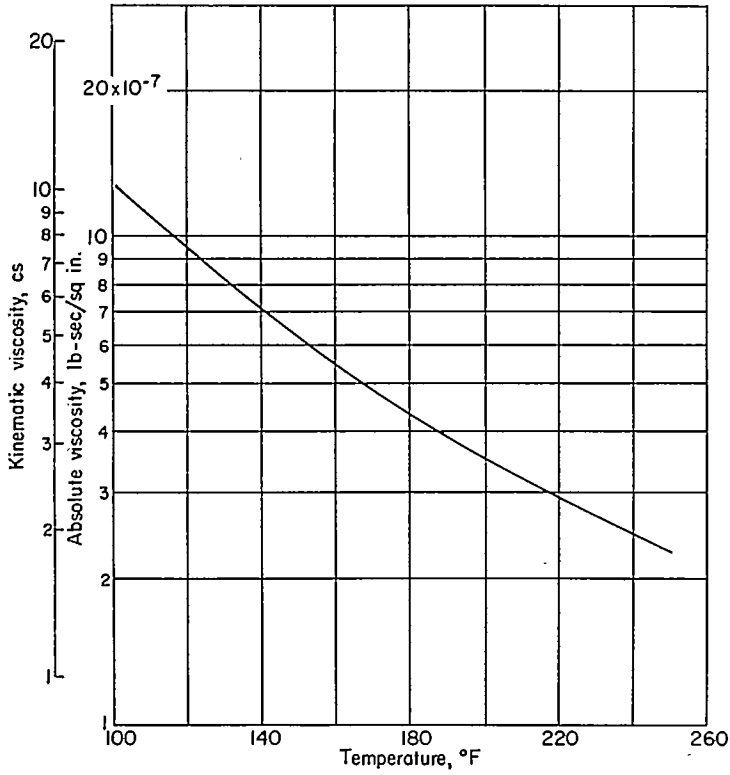

FIGURE 3.—Effect of temperature on kinematic and absolute viscosities of test oil. Pour point, less than -75°F ; flash point, 300°F ; viscosity index, 75; autogenous ignition temperature, 500°F (time lag before ignition at temperature indicated was under 2 min).

CAGE-DESIGN INVESTIGATION

DN VALUE

Effect of *DN* on operating temperatures.—Figure 4 shows the effect of *DN* (values to 1.2×10^6) on the outer-race maximum temperature of test bearings A to F at oil flows of 2.0, 2.75, 5.5, and 8.0 pounds per minute. The outer-race maximum temperature of each of the six test bearings is very nearly a linear function of *DN* value at all four oil flows over this range of *DN* values. Bearings B, C, D, and E operated at lower temperatures than did bearings A and F under all conditions of operation, the difference in operating temperatures becoming greater with increasing *DN*. This indicates that the four experimental bearing types were more effectively lubricated and cooled at all four oil flows than were the two conventional designs. Among the four experimental types, bearings D and E (cage-locating pads between the rollers) operated at slightly lower temperatures than did bearings B and C (cage-locating surfaces outside the roller track). However, the operating temperatures of bearings B and C varied only 4°F from those of bearings D and E at a *DN* of 1.2×10^6 . The cages of bearings B and C have a slightly greater tendency to trap oil than do those of bearings D and E.

The curves of figure 4 show that bearing A operates at significantly higher temperatures than the four experimental bearings at the two lowest oil flows, while bearing F operates at the highest temperatures at the two highest oil flows. These results indicate that the interior surfaces of bearing A were not properly lubricated and cooled at the low oil flows and that a high-velocity oil jet is required for sufficient oil

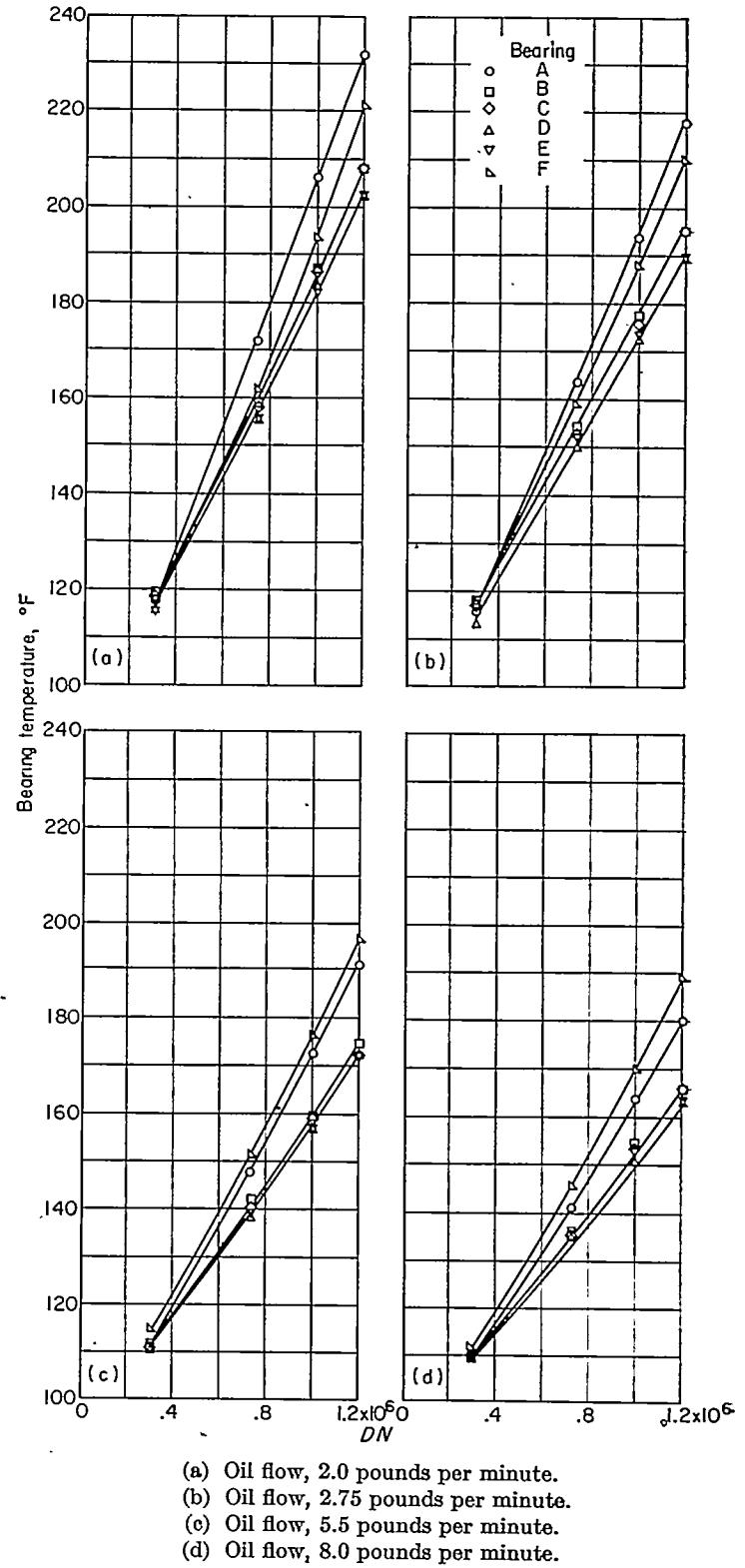

- (a) Oil flow, 2.0 pounds per minute.
- (b) Oil flow, 2.75 pounds per minute.
- (c) Oil flow, 5.5 pounds per minute.
- (d) Oil flow, 8.0 pounds per minute.

FIGURE 4.—Effect of *DN* on bearing outer-race maximum temperature at four oil flows for bearings A to F. Load, 368 pounds; oil inlet temperature, 100°F .

to penetrate through the small space between the cage and inner race. The results also indicate that, while bearing F was adequately lubricated at the two lowest oil flows, considerable oil entrapment between the outer-race flanges occurred at the higher oil flows and resulted in heat generation due to oil churning.

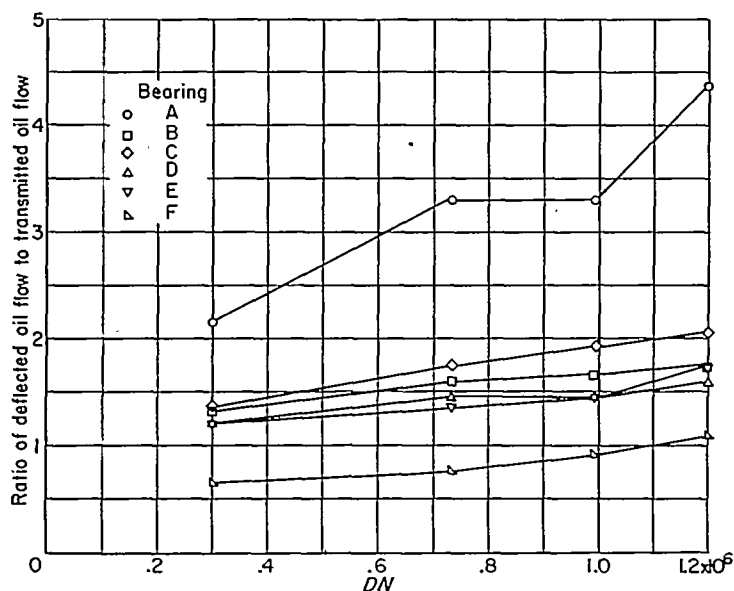
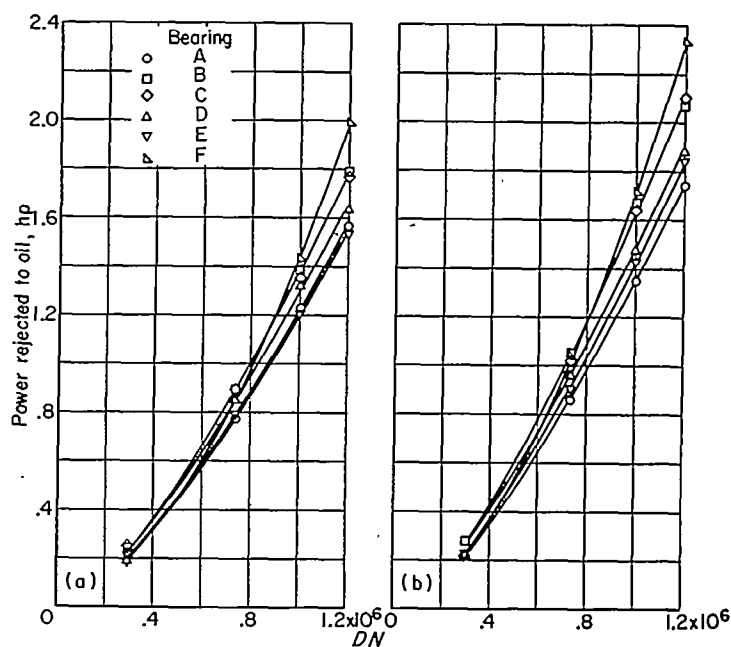

FIGURE 5.—Effect of DN on ratio of deflected to transmitted oil flows for bearings A to F. Load, 368 pounds; oil flow, 2.75 pounds per minute; oil inlet temperature, 100° F.

It can be seen then that high operating temperatures result with the conventional inner-race-riding cage-type bearing because of its inherent difficulty of lubrication and cooling and with the conventional outer-race-riding cage-type bearing because of its tendency to trap oil and create high churning losses. Bearings B, C, D, and E operated at lower temperatures than did the conventional bearings, because the lubricant had easy access to the interior surfaces plus a low resistance path to exit from the bearing.

Cage-pocket type had little effect on bearing operating temperature, as is evidenced by the fact that the curves of bearings B and C and those of bearings D and E are coincident at DN values to 1.2×10^6 .

Effect of DN on ratio of deflected oil flow to transmitted oil flow.—Figure 5 shows the effect of DN on the ratio of deflected oil flow (that oil which is collected on the side of the oil jet) to transmitted oil flow (that oil which is collected on the side opposite the oil jet) for test bearings A to F. The curves illustrate the relative ease of lubricant flow into and through the bearing types under investigation (transmitted oil flow increases with decreasing flow ratio). For all six test bearings, the flow ratio increased with increasing DN because of the greater tendency to throw oil off the face of the bearing at higher rotative speeds. The flow ratio was highest for bearing A, because it offered the greatest resistance to lubricant flow; and lowest for bearing F, because its straight-through inner race offered little resistance to lubricant flow. Since bearings B, C, D, and E had only 16 rollers while bearing A had 20 rollers, the total of all the voids between the rollers was some 33 percent greater in bearings B, C, D, and E. This could account in part for the greater resistance to lubricant flow, but the major resistance to flow in bearing A was the small space between the cage and inner race.



(a) Oil flow, 2.0 pounds per minute.
 (b) Oil flow, 2.75 pounds per minute.

FIGURE 6.—Effect of DN on power rejected to oil at two oil flows for bearings A to F. Load, 368 pounds; oil inlet temperature, 100° F.

Effect of DN on power rejected to oil.—Figure 6 shows the effect of DN on power rejected to the oil at oil flows of 2.0 and 2.75 pounds per minute for test bearings A to F. The heat dissipated to the oil is lowest for bearing A, because this type of bearing is inherently difficult to cool. This advantage, although small when compared with the heat dissipated to the oil for bearings B, C, D, and E, is gained only at the expense of the higher operating temperatures previously discussed. The heats dissipated to the oil for bearings D and E are only slightly greater than for bearing A and are somewhat less than those for bearings B and C. The higher heats dissipated to the oil for bearings B and C may be due to the greater tendency of their cages to trap oil and create churning losses higher than those in bearings D and E. The curves for bearing F show that its heat dissipation to the oil does not exceed those of the other bearings until DN values of about 0.85×10^6 (approximately 11,000 rpm) are reached. At higher speeds, however, its heat dissipation to the oil becomes significantly greater than those of the other bearings. These results illustrate the effects of oil entrapment and the consequent churning losses, which do not become significant until high speeds are reached. The combination of a double-flanged outer race and an outer-race-riding cage, not provided with adequate oil-drainage paths, results in excessive oil churning losses at high rotative speeds.

The fact that the curves for bearings B and C and those for bearings D and E are nearly coincident indicates that cage-pocket type (broached or fitted) has little or no effect on the heat dissipated to the oil.

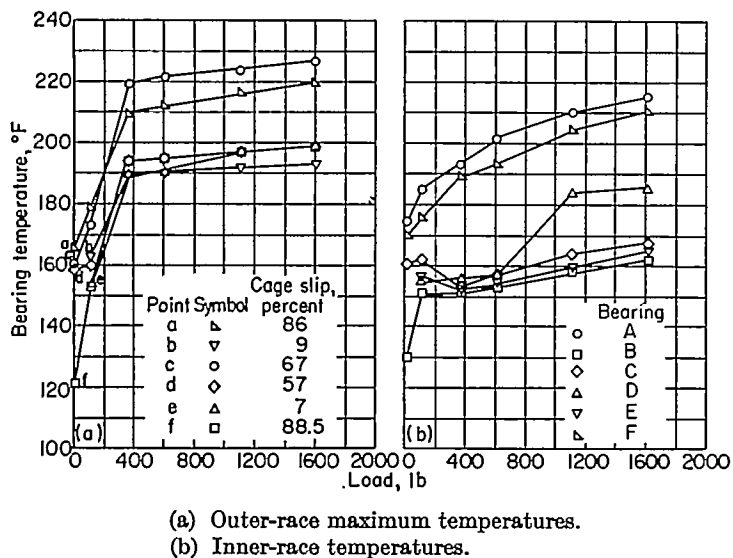

FIGURE 7.—Effect of load on bearing outer-race maximum and inner-race temperatures for bearings A to F. DN , 1.2×10^6 ; oil flow, 2.75 pounds per minute; oil inlet temperature, 100° F.

LOAD

The effect of load on bearing outer-race maximum and inner-race temperatures for test bearings A to F is shown in figure 7. As the load was increased from 368 to 1613 pounds, outer-race maximum temperatures increased only slightly, while inner-race temperatures increased at a somewhat greater rate. As the load was increased from 7 and 113 pounds to 368 pounds, outer-race maximum temperatures increased sharply because of the decrease in cage slip. At low loads, roller slip occurs between the rollers and inner race, causing the cage to slip or to rotate at a rotational speed somewhat below its theoretical rotational speed. Percentage cage slip is defined as follows:

$$\text{Percentage cage slip} = \left(\frac{N_{cr} - N_c}{N_{cr}} \right) 100$$

where
 N_{cr} theoretical cage rotational speed, rpm
 N_c actual cage rotational speed, rpm

At the lowest loads, cage slip varied from 7 to 88.5 percent and was responsible for the decreased rate of heat generation. Inner-race temperatures, however, do not always rise as sharply in going from the low-load to the high-load range, because the rolling and sliding contact which exists between the inner race and rollers when cage slip is present apparently generates nearly as much heat as the pure rolling contact which exists at zero cage slip.

Cage slip is later shown in the section CAGE-SLIP TESTS to be a cause of high wear in cylindrical roller bearings; consequently, operation at light loads should be avoided. The cause of the erratic shape of the inner-race temperature curve for bearing D is unknown; excessive vibration accompanied the sharp rise when the load was increased from 613 to 1113 pounds.

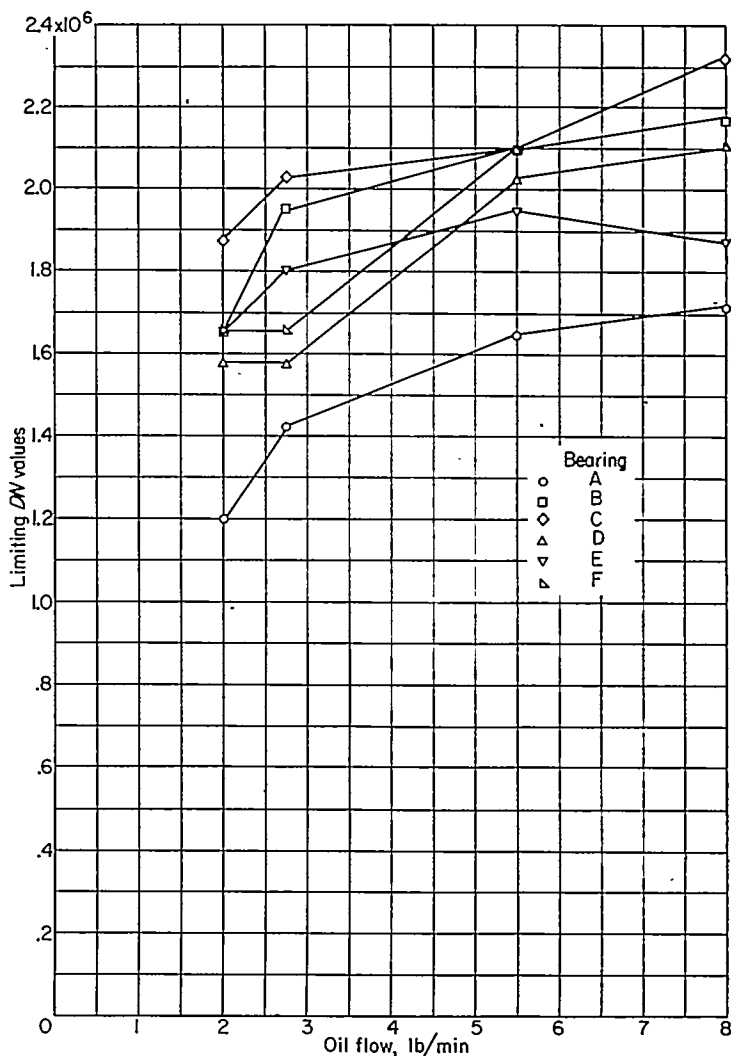

FIGURE 8.—Effect of oil flow on limiting DN value for bearings A to F. Load, 368 pounds; oil inlet temperature, 100° F.

HIGH-SPEED OPERATING CHARACTERISTICS

Effect of oil flow on limiting DN value.—Each of the six test bearings was run to its limiting DN value from a temperature standpoint only (that speed at which the bearing would not operate at an equilibrium temperature or at which bearing temperature rose rapidly, indicating an incipient failure) at oil flows of 2.0, 2.75, 5.5, and 8.0 pounds per minute. The results shown in figure 8 indicate that, in general, limiting DN values increase with increasing oil flow. The outer-race-riding cage-type bearings exhibited significantly higher limiting speeds than did bearing A. Bearing A would not run at DN values above 1.72×10^6 (23,000 rpm), whereas bearing C was operated successfully at a DN value of 2.32×10^6 (31,000 rpm). The type of cage used in bearing C seems to be best suited to ultra-high-speed operation. Of the four experimental bearings, bearing E showed the poorest high-speed operating characteristics; this may have been due to a weakness in design or to the relatively small diametral clearance in this bearing.

Although bearing F was successfully operated at a DN value of 2.1×10^6 (28,000 rpm), operating temperatures above a DN of 1.5×10^6 were extremely erratic because of high cage slip, which produced extremely high wear as discussed in the section WEAR DATA.

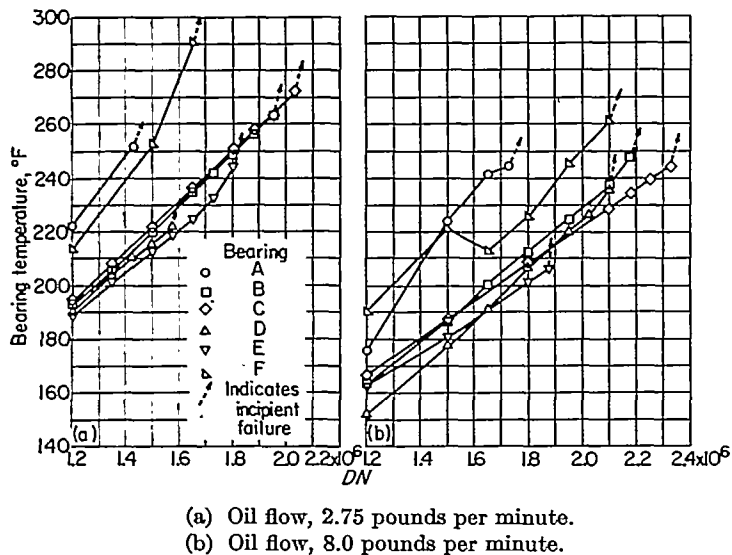

FIGURE 9.—Bearing outer-race maximum temperature as function of DN at very high speeds at two oil flows for bearings A to F. Load, 368 pounds; oil inlet temperature, 100° F.

Effect of DN on operating temperatures at very high speeds.—Curves of bearing outer-race maximum temperature as a function of DN at very high speeds for test bearings A to F are shown in figure 9 at oil flows of 2.75 and 8.0 pounds per minute. It is evident that the linear relation which existed at low speeds (fig. 4) does not hold for all test bearings at very high speeds. The curves for bearings B, C, D, and E are generally linear, but those of bearings A and F are quite erratic and indicative of unstable operation at very high speeds. At an oil flow of 2.75 pounds per minute, the slope of the curve for bearing F showed a marked tendency to increase with speed, probably because of the increasing rate of heat generation due to oil churning. Thus, the basic weakness of this design becomes more apparent at very high speeds. At an oil flow of 2.75 pounds per minute and a DN of 1.65×10^6 , bearing F operated at a temperature 54° F higher than did bearing C. The curve for bearing F at an oil flow of 8.0 pounds per minute is quite interesting in that the bearing temperature decreased when the speed was increased from a DN of 1.5×10^6 to 1.65×10^6 . This unusual phenomenon was caused by a sudden increase in cage slip from 1 or 2 percent to 35 percent.

WEAR DATA

Wear data for the test-bearing component parts (wear indicated by weight loss) are shown in bar graphs in figure 10. These data, together with thorough visual inspections, are invaluable because they reveal the critical or weak points in the various bearing designs. However, because wear is such a complex phenomenon, the data should be used only qualitatively and not quantitatively.

Heaviest wear in bearing A occurred between the roller ends and the inner-race roller-track flanges. In bearing A very little oil gets to this location, because it is difficult for

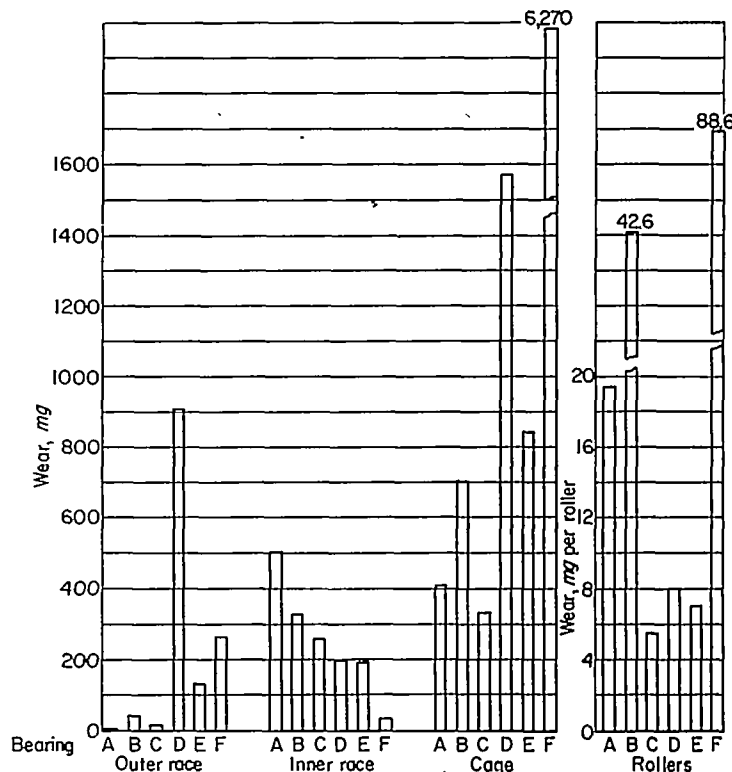

FIGURE 10.—Wear of component parts of bearings A to F.

the oil to penetrate through the small space between the inner-race flange and the cage inside periphery; whatever oil does pass through this barrier is immediately thrown outward by centrifugal force.

Heavy wear occurred in bearing B in the cage-roller pockets, with the rollers sustaining especially heavy wear. In contrast, no severe wear occurred at any point in bearing C. Since the cages of bearings B and C were alike except for cage-pocket design, the more intimate contact produced by the fitted pockets of bearing B together with their relatively greater inaccessibility to the lubricant may have contributed to the higher wear. Neither bearing B nor C sustained any significant wear at its cage-locating surface.

In bearing D heavy wear occurred at the cage outside periphery and at the outer-race inside periphery. Apparently, cage-locating pads of bearing D were not of sufficient size to support loads between the cage and its locating surface, because very little wear occurred at this point in bearing E which had cage-locating pads that were about 60 percent larger than those of bearing D. Bearing E sustained greater wear in the cage pockets than did bearing D. Here again, broached roller pockets seem to be superior to fitted roller pockets.

In bearing F severe wear occurred in the cage-roller pockets. Both cage and roller wear were extreme; these high values of wear were found to be the result of the high cage slip which occurred at DN values above 1.5×10^6 at the higher oil flows. The possible causes of this cage slip, are discussed in the following section.

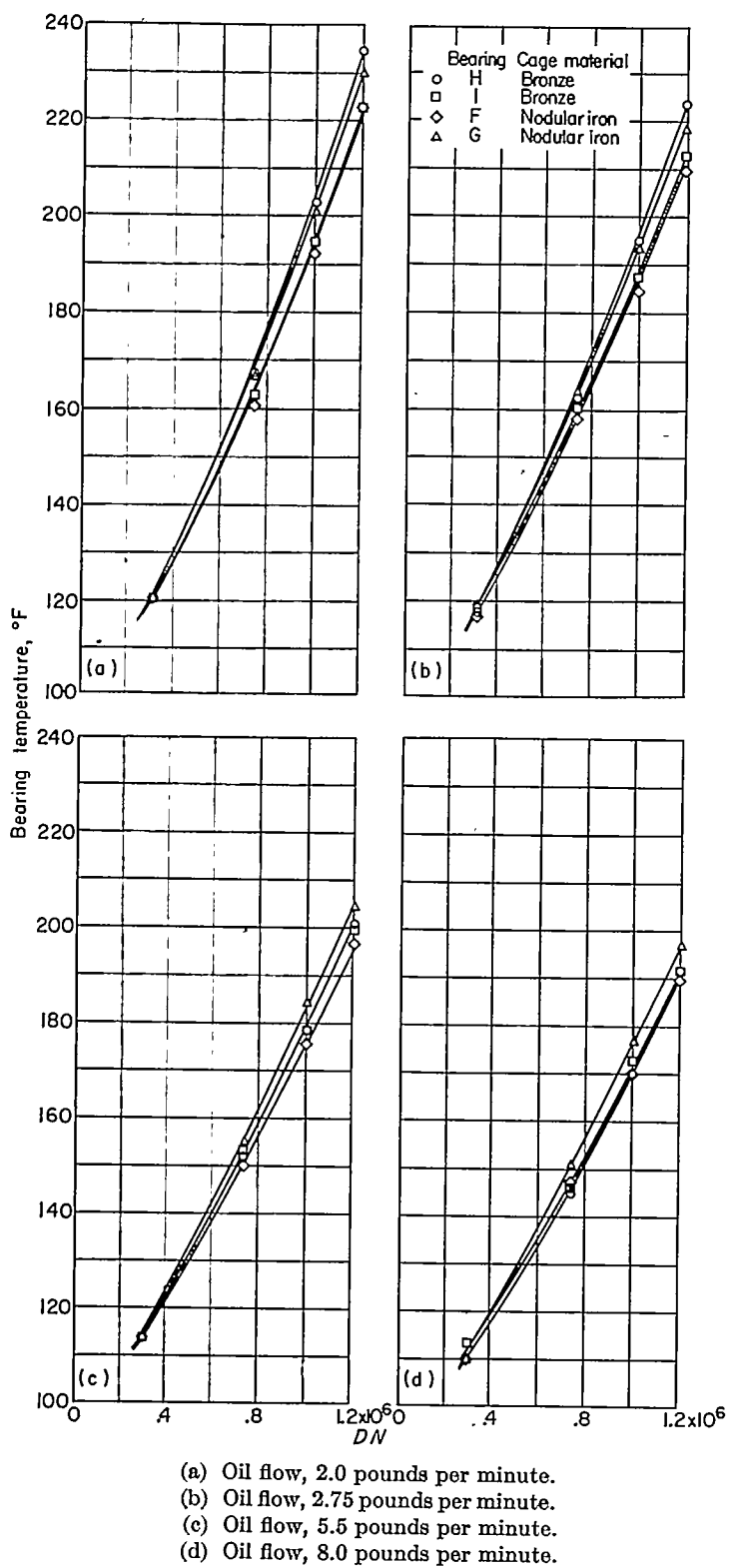

FIGURE 11.—Effect of DN on outer-race maximum temperatures of bearings F to I at four oil flows. Load, 368 pounds; oil inlet temperature, 100° F.

CAGE-MATERIAL INVESTIGATION
 LOW-SPEED TESTS

Effect of DN on operating temperatures.—The effect of DN on the outer-race maximum temperatures of bearings F

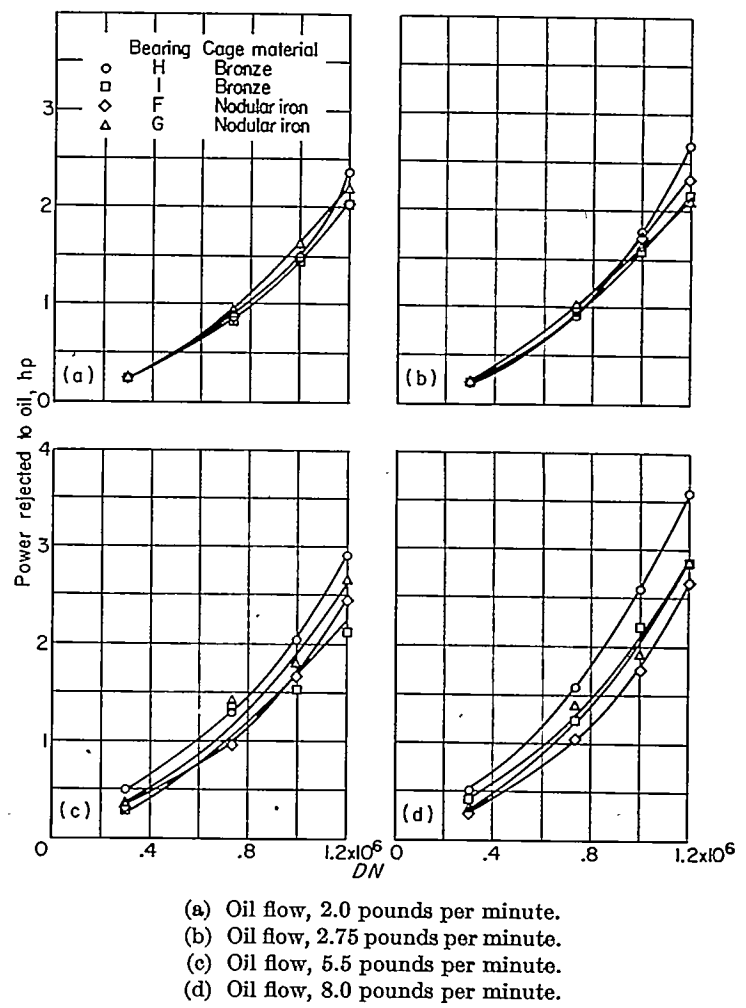

FIGURE 12.—Effect of DN on power rejected to oil in bearings F to I at four oil flows. Load, 368 pounds; oil inlet temperature, 100° F.

to I is shown in figure 11. Curves for oil flows of 2.0, 2.75, 5.5, and 8.0 pounds per minute are shown. Differences in operating temperatures for the four test bearings were small, with the maximum difference in bearing temperatures occurring at an oil flow of 2.75 pounds per minute and a DN of 1.2×10^6 .

Effect of DN on power rejected to oil.—The effect of DN on the power rejected to the oil in bearings F to I is shown in figure 12. Curves for oil flows of 2.0, 2.75, 5.5, and 8.0 pounds per minute are shown. Differences in the power rejected to the oil in the test bearings became greater at the higher oil flows. The power rejected in bearing H is seen to be greater at the two highest oil flows than that in bearings F, G, and I. Since only the power rejected in bearing H and not that in both bearings H and I seems to be high, the differences are probably due to test conditions, and not to variations in frictional characteristics of the two cage materials. At the conclusion of the tests of bearing H, it was discovered that a slight load misalignment had existed during the tests. This condition manifested itself in the form of slightly greater roller wear on one end than on the other and in slightly uneven wear patterns in the cage pockets. This condition could have been responsible for the discrepancy in results between bearings H and I.

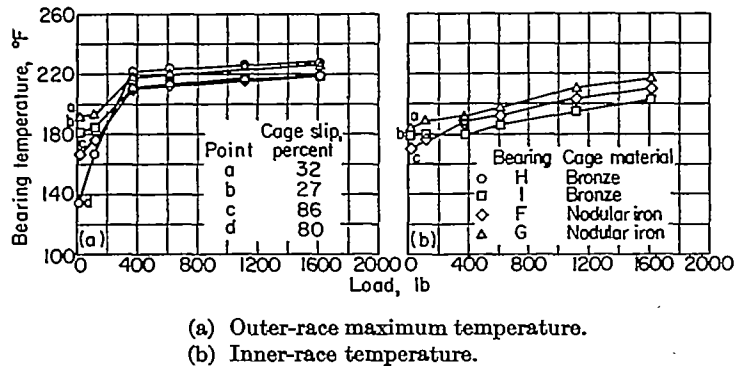

FIGURE 13.—Effect of load on outer-race maximum and inner-race temperatures of bearings F to I. $DN, 1.2 \times 10^6$; oil flow, 2.75 pounds per minute; oil inlet temperature, $100^\circ F$.

Effect of load on operating temperatures.—Figure 13 shows the effect of load on both the outer-race maximum and the inner-race temperatures of bearings F to I. Inner-race data for bearing H are not shown, because the inner-race thermocouple system was inoperative during that test. The curves for all bearings are similar in shape with the greatest discrepancies between bearings occurring at the two lowest loads, where slip occurred between the rollers and the inner race, causing the cage to slip or to rotate at a rotational speed somewhat less than its theoretical rotational speed.

Reproducibility of bearing temperature cannot be obtained at loads where any appreciable amount of cage slip occurs. Although care was taken to assemble test bearings with nearly identical diametrical clearances, cage slip varied from 27 to 86 percent in bearings F to I when running at a load of 7 pounds, an oil flow of 2.75 pounds per minute, and a DN value of 1.2×10^6 . Values of cage slip for bearings F to I operating at this combination of conditions are shown by points a to d in figure 13. It has been found impossible to duplicate cage slip in the same bearing from day to day. The data of figure 13 show that, at a load of 7 pounds, the two bearings with greatest slip had the lowest temperatures.

It is evident from the curves of figure 13 that outer-race maximum temperatures increase sharply in going from the low-load to the high-load range while inner-race temperatures do not. The cause of this phenomenon is explained in the previous discussion of the effect of load.

At the conclusion of the load tests, the characteristic inner-race frosting, which accompanies roller sliding and cage slip, was observed on bearings F, G, and H.

Test-bearing wear.—The low-speed-test wear data (wear indicated by weight change) for the test-bearing component parts are tabulated in table V(a). The data show that there is little difference in wear characteristics between the bronze and nodular iron investigated at DN values to 1.2×10^6 (16,000 rpm), although the nodular iron cages did show slightly greater wear. At 16,000 rpm and zero cage slip, the sliding velocity is 7970 feet per minute at the cage-locating surface and 7310 feet per minute in the cage pockets. The wear of all test-bearing component parts was low and

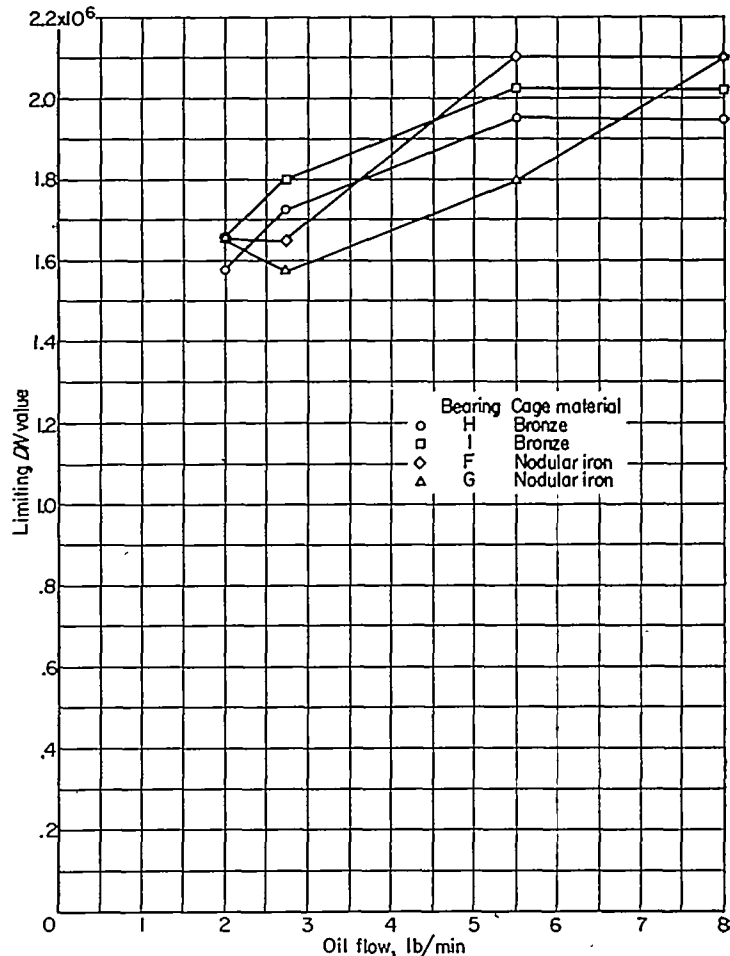

FIGURE 14.—Effect of oil flow on limiting DN values for bearings F to I. Load, 368 pounds; oil inlet temperature, $100^\circ F$.

not indicative of any severe bearing-life limitations at speeds to 16,000 rpm.

HIGH-SPEED TESTS

Effect of oil flow on limiting DN values.—The effect of oil flow on the limiting DN values for bearings F to I is shown in figure 14. At each oil flow, each test bearing was run until an equilibrium operating temperature could no longer be obtained. Limiting DN values, in general, increased with increasing oil flow, and variations in limiting DN values between bearings were relatively small.

Bearing operating temperatures at very high speeds.—Figure 15 shows plots of bearing outer-race maximum temperature as functions of DN values from 1.2×10^6 to the limiting values for bearings F to I. Curves for oil flows of 2.0, 2.75, 5.5, and 8.0 pounds per minute are shown. Unlike the DN curves at low speeds, the curves become rather erratic at high speeds, especially at the two highest oil flows. During the course of the investigation, it was found that the sharp changes in slope occur at the onset of cage slip. The tests seem to indicate that a roller bearing is capable of absorbing only a fixed amount of torque when operating at a specific load and oil flow. When this limiting bearing torque is reached, the maximum friction force that can be

developed between the rollers and inner race is being utilized. An increase in shaft speed beyond that at which the maximum bearing torque is developed will result in cage slip. Several significant points on figure 15 are identified, and the corresponding values of cage slip are tabulated on the figure. At an oil flow of 5.5 pounds per minute, the slope of the curve for bearing F decreased in going from point a to point b, and at the same time cage slip increased from 2 to 30 percent. At the same oil flow, the curve for bearing G exhibited a marked increase of slope in going from point c to point d; this change was accompanied by a decrease in cage slip from 23 to 5 percent. Sharp changes in slope apparently indicate changes in cage slip.

Test-bearing wear.—The high-speed-test wear data for the test-bearing component parts are tabulated in table V(b). The data show that the bearings with bronze cages incurred much less wear than did the bearings with nodular iron cages at bearing DN values above 1.2×10^6 (16,000 rpm). Maximum sliding velocities (assuming no cage slip) in the test bearings at DN values of 1.2×10^6 to 2.1×10^6 are 7970 to 13,950 feet per minute. Cage, roller, and outer-race

wear were severe in both bearings F and G. Roller wear was heavy in bearing H, presumably because of the slight load misalignment discussed in the section **LOW-SPEED TESTS**. The most significant indication of the high-speed wear data is the relative wear of the four test-bearing cages. The results of basic friction and wear tests (ref. 7) and of low-speed tests reported herein (which show negligible wear) indicate strongly that the excessive wear incurred by the nodular iron cages results not only from differences in material properties but also from other factors. Comparison of the high-speed DN curves (fig. 15) and the high-speed-test wear data (table V(b)) suggests strongly that cage slip is responsible, at least in part, for high wear rates and is therefore highly detrimental to bearing life.

CAGE-SLIP TESTS

The exact effects of increased cage slip, other than the tendency to reduce bearing torque and bearing operating temperatures because of reduced sliding velocities within the bearing, were unknown at the time the high-speed tests were run, so special tests were run to determine the effect of cage slip on the wear rates of the bearing component parts. These results are discussed in the following section.

Effect of cage slip on wear rates of test-bearing component parts.—To determine the effect of cage slip on wear rates, three tests were run using bearing I. Bearing I was chosen because it had sustained the least wear of all four test bearings and was not worn to any damaging extent. Three tests, each of 4 hours duration, were run at a DN value of 1.2×10^6 and an oil flow of 2.75 pounds per minute. The load during each test was different in order to vary the cage slip. The results of these tests are tabulated in table VI. The data of table VI show that test bearing I incurred no appreciable wear when cage slip was as high as 30 percent but that very severe wear occurred at 95-percent cage slip. At the start of the run at a load of 7 pounds, cage slip was about 40 percent and did not reach 95 percent until about 30 minutes had elapsed. The gradual increase in cage slip was accompanied by a steady decline in bearing temperatures indicative of the decreased rate of heat generation within the bearing.

Comparison of these results with those of the low-speed tests, where values of cage slip of 80 and 86 percent were obtained in bearings H and F at a load of 7 pounds and a DN of 1.2×10^6 (fig. 13), shows a marked difference in wear. The wear during the low-speed tests may have been low because of the short time (approx. 15 min) the bearings were run under these conditions. At DN values of 1.5×10^6 and higher and at a load of 368 pounds, very severe wear occurred at values of cage slip on the order of 30 percent in bearings F and G (see fig. 15 and table V(b)).

Cage material undoubtedly has an effect on wear rate, but for both cage materials investigated the results seem to indicate that additional important factors affecting wear are the sliding velocities and the loads between the component parts. The sliding velocity between the rollers and inner race is, in turn, a function of the percentage cage slip and the DN value.

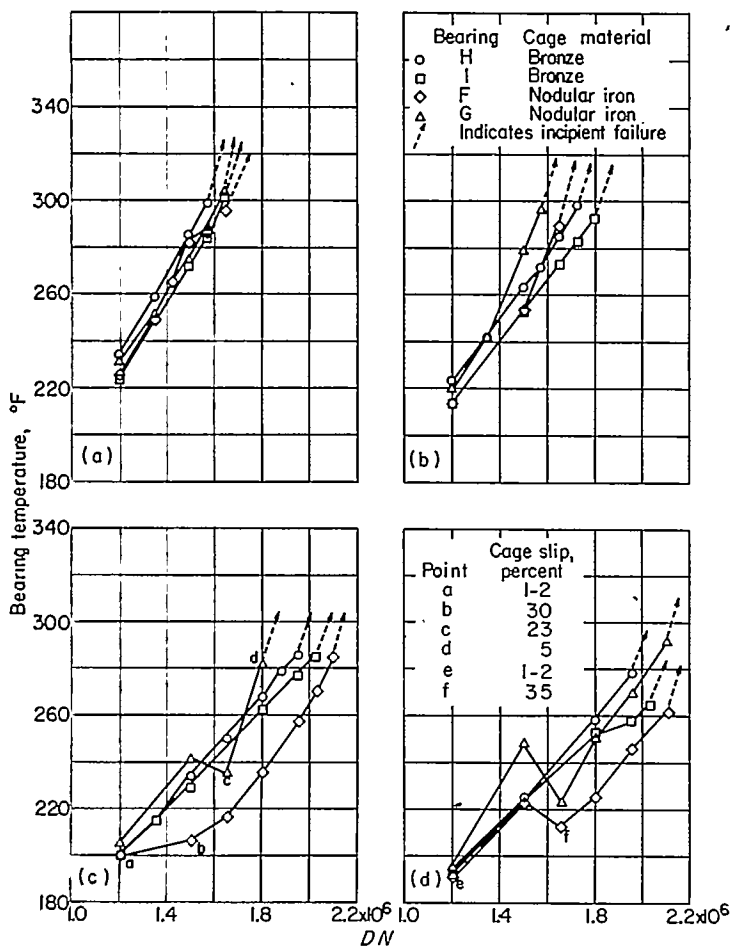

- (a) Oil flow, 2.0 pounds per minute.
- (b) Oil flow, 2.75 pounds per minute.
- (c) Oil flow, 5.5 pounds per minute.
- (d) Oil flow, 8.0 pounds per minute.

FIGURE 15.—Bearing outer-race maximum temperature as affected by DN values from 1.2×10^6 to limiting value at four oil flows for bearings F to I. Load, 368 pounds; oil inlet temperature, 100° F.

It can be concluded then that cage slip, despite the fact that it is accompanied by a decrease in heat generation, is extremely harmful, from a wear standpoint, to a cylindrical roller bearing with an outer-race-riding cage. For this reason, nodular iron cannot be recommended as a cage material for this type of high-speed roller bearing, because it apparently tends to promote cage slip. In reference 7 it is shown that nodular iron, although exhibiting low wear rates in sliding against SAE 52100 steel, showed higher coefficients of friction in many cases than did bronze. It seems most probable that, with nodular iron cages under poor lubrication conditions introduced by high sliding speeds, the friction forces between the cage and rollers and between the cage and outer race become great enough to exceed the tractive force between the rollers and inner race. When this happens, cage slip occurs, causing surface welding between the rollers and inner race. Transferred and loose particles of steel that result from failure in sliding serve to abrade and lap, producing the characteristic frosted appearance on the inner race. The loose particles of steel would accelerate wear of all component parts, and the transferred metal could accelerate wear of all surfaces contacting the periphery of the rollers.

Effect of cage slip on limiting DN values.—Limiting DN value was previously defined as the highest DN at which the bearing under investigation would operate at an equilibrium temperature. In the light of the cage-slip and high-speed test results, however, it might be advisable to modify that definition to include the condition that no damaging cage slip occur. The limiting DN value for a bearing operating at a specific load and lubricated in a specific manner would then be the highest DN value at which the bearing would run at an equilibrium temperature without damaging cage slip; limiting DN value would thus be a function of load, oil flow, and operating diametrical clearance, as well as other factors such as surface finish.

GENERAL OBSERVATIONS

Several critical clearances which reflect the magnitude of the wear at different points in the bearings are tabulated in table II. It was observed that inner-race frosting accompanied cage slip in test bearings and that in bearings with nodular iron cages the races and rollers appeared highly polished where not frosted.

As shown in table III, test-bearing-hardness measurements changed little during the tests. Roller and cage hardnesses show a consistent small decrease, while race hardnesses decreased slightly in some instances and remained constant in other cases.

Test-bearing surface finishes (table IV) generally became rougher during the tests. Frosting considerably roughened the inner races, and heavy roller wear resulted in rougher surface finishes on both roller periphery and ends.

SUMMARY OF RESULTS

Two investigations, one to determine the relative merits of four experimental and two conventional design 75-millimeter-bore (size 215) cylindrical roller bearings (each equipped with a different design nodular iron cage), and one

to determine the relative merits of nodular iron and bronze as cage materials (using four conventional outer-race-riding cage-type bearings, two with nodular iron and two with bronze cages), are reported herein. Nine test bearings were operated over a range of DN values (product of bearing bore in mm times shaft speed in rpm) from 0.3×10^6 to 2.3×10^6 , radial loads from 7 to 1613 pounds, and oil flows from 2 to 8 pounds per minute with a single-jet circulatory oil feed.

The following results were obtained in the investigation of bearing designs:

1. The experimental combination of an outer-race-riding cage with a straight-through outer race and inner-race-guided rollers was found to give the best over-all performance based on limiting DN values and bearing temperatures. The better performance of this type bearing over both the conventional inner-race-riding cage type and the conventional outer-race-riding cage type with outer-race-guided rollers was a result of relative ease of lubrication and cooling and of adequate oil exiting paths which minimize oil entrapment and churning losses.

2. Of the two basic types of experimental outer-race-riding cages investigated, those with piloting surfaces outside the roller track were operated successfully at higher DN values (2.32×10^6) than were those with piloting surfaces between the rollers. On the other hand, the latter type of cage operated at slightly lower temperatures, presumably because of reduced oil entrapment and churning losses.

3. The conventional inner-race-riding cage-type bearing could not be successfully operated at DN values above 1.72×10^6 because it is inherently difficult to lubricate and cool. For the same reason, the operating temperatures of this type bearing were higher than those of the four experimental bearing types throughout the range of speed and oil flow investigated. The heat dissipation to the oil was, however, slightly lower for this type of bearing than for the experimental types.

4. The conventional outer-race-riding cage-type bearing with outer-race-guided rollers operated successfully at a DN value of 2.1×10^6 but incurred very severe cage and roller wear at very high speeds because of high cage slip. This type bearing was found to be adequately lubricated and cooled at relatively low oil flows (2.0 and 2.75 lb/min). At oil flows of 5.5 and 8.0 pounds per minute, however, this type bearing operated at higher temperatures than the other test bearings because of excessive churning losses. At DN values above 0.85×10^6 , the heat dissipated to the oil for this bearing exceeded that of the other test bearings, presumably because of high churning losses. Temperatures and heat dissipation to the oil increased at a greater rate with increasing DN for this type bearing than for the other types investigated.

5. Cage-pocket type (broached or fitted) had little or no effect on bearing operating temperature or heat dissipated to the oil. Both cages with fitted pockets incurred greater wear in the roller pockets than did their prototypes with broached pockets, presumably because of the more intimate roller contact produced by fitted pockets and the greater inaccessibility of fitted pockets to lubricant flow.

The following results, which are applicable with certainty only to the type of bearing tested, were obtained in the investigation to determine the relative merits of nodular iron and bronze as cage materials:

1. Wear rates varied with cage slip and appeared to be a function of cage material and also of the sliding velocity and load between the rollers and inner race.

2. Cage slip occurred more readily at DN values above 1.2×10^6 with nodular iron cages than with the bronze cages investigated. Consequently, bearings with nodular iron cages showed more wear of rollers and cages (especially in cage-roller pockets) than did bearings with bronze cages.

3. The severe roller and cage wear obtained in the bearings with nodular iron cages suggest that roller-pocket and cage-locating-surface friction may, under certain operating conditions, exceed the tractive force between the rollers and inner race and may therefore be responsible for the onset of cage slip.

4. Cage slip in bearings with bronze cages was accompanied by severe roller wear and light cage wear in the cage-roller pockets. This fact, together with the severe cage wear associated with nodular iron cage-type-bearing slip, suggests that cage material may be a factor in reducing cage wear in a bearing operating under slip conditions.

5. There was little difference in performance between the bronze and nodular iron cages as measured by bearing temperature, heat dissipation to the oil, and bearing wear at DN values to 1.2×10^6 (16,000 rpm). The wear in all test bearings at speeds to 16,000 rpm was light and was not of a magnitude that would indicate a very limited life.

NATIONAL ADVISORY COMMITTEE FOR AERONAUTICS
 LEWIS FLIGHT PROPULSION LABORATORY
 CLEVELAND, OHIO, June 30, 1954

REFERENCES

1. Hunt, Kenneth C.: Petroleum Requirements of British Gas Turbines. II—Lubricants. SAE Jour., vol. 59, no. 11, Nov. 1951, pp. 20-21.
2. DuBois, Ralph H.: Interesting Applications of Roller Bearings. Presented before Southern New England Section of SAE. (See also discussion, SAE Jour., vol. 60, no. 4, Apr. 1952, pp. 112 and 115.)
3. Boyd, John, and Eklund, P. R.: Some Performance Characteristics of Ball and Roller Bearings for Aviation Gas Turbines. Paper

- No. 51-A-78, Aviation Div., presented at A.S.M.E. meeting, Atlantic City (N. J.), Nov. 25-30, 1951.
4. Phillips, E. M.: Lubrication—Bearing Problems in Aircraft Gas Turbines. Mech. Eng., vol. 73, no. 12, Dec. 1951, pp. 983-988.
5. Jones, A. B.: The Life of High Speed Ball Bearings. Trans. A.S.M.E., vol. 74, no. 5, July 1952, pp. 695-699; discussion, pp. 699-703.
6. Dawson, J. G.: Lubricating Problems of the Gas Turbine Engine. Shell Aviation News, no. 133, July 1949, pp. 14-22.
7. Johnson, Robert L., Swikert, Max A., and Bisson, Edmond E.: Investigation of Wear and Friction Properties under Sliding Conditions of Some Materials Suitable for Cages of Rolling-Contact Bearings. NACA Rep. 1062, 1952. (Supersedes NACA TN 2384.)
8. Johnson, Robert L., Swikert, Max A., and Bisson, Edmond E.: Wear and Sliding Friction Properties of Nickel Alloys Suited for Cages of High-Temperature Rolling-Contact Bearings. I—Alloys Retaining Mechanical Properties to 600° F. NACA TN 2758, 1952.
9. Johnson, Robert L., Swikert, Max A., and Bisson, Edmond E.: Wear and Sliding Friction Properties of Nickel Alloys Suited for Cages of High-Temperature Rolling-Contact Bearings. II—Alloys Retaining Mechanical Properties Above 600° F. NACA TN 2759, 1952.
10. Maeks, E. Fred, and Nemeth, Zoltan N.: Investigation of 75-Millimeter-Bore Cylindrical Roller Bearings at High Speeds. I—Initial Studies. NACA TN 2128, 1950.
11. Maeks, E. F., Nemeth, Z. N., and Anderson, W. J.: Operating Characteristics of Cylindrical Roller Bearings at High Speeds. Trans. A.S.M.E., vol. 74, no. 5, July 1952, pp. 705-710; discussion, pp. 711-713.
12. Tarr, Philip R.: Methods for Connection to Revolving Thermocouples. NACA RM E50J23a, 1951.

TABLE I.—PROPERTIES AND COMPOSITION OF CAGE MATERIALS

Material.....	Bronze	Nodular iron*
Yield point, psi.....	32,000-37,000	b 50,500
Tensile strength, psi.....	65,000-73,000	80,500
Elongation, percent.....	25-35	2
Reduction of area, percent.....	20-30	1.5
Modulus of elasticity, psi.....	15×10^6	20.9×10^6
Chemical composition, percent.....	Cu 61.4 Zn 38.5 Pb 1.0 Al 1.1	C 3.70 Mn .33 Si 2.33 Cr .02 Cu .47 P .03 S .011 Mg .061

* Obtained from the Ford Motor Company foundry.
 b Specimen taken from 2¼-in. radius of 6-in.-diameter by 12-in.-long ingot.

REPORT 1177—NATIONAL ADVISORY COMMITTEE FOR AERONAUTICS

TABLE II.—DIMENSIONS OF TEST BEARINGS

Bearing.....	A		B		C		D		E		F		G		H		I	
	Before	After	Before	After	Before	After	Before	After	Before	After	Before	After	Before	After	Before	After	Before	After ^a
Pitch diameter of bearing, in.	4.036		4.036		4.036		4.036		4.036		4.036		4.036		4.036		4.036	
Length-diameter ratio of rollers	1		1		1		1		1		1		1		1		1	
Number of rollers.....	20		16		16		16		16		20		20		20		20	
Cage material.....	Nodular iron		Nodular iron		Nodular iron		Nodular iron		Nodular iron		Nodular iron		Nodular iron		Bronze		Bronze	
Cage type.....	One piece, broached pockets, located on inner-race flanges.		Two piece, fitted pockets, located on outer-race inside diameter outside the roller track.		One piece, broached pockets, located on outer-race inside diameter outside the roller track.		One piece, broached pockets, located on outer-race inside diameter between the rollers.		Two piece, fitted pockets, located on outer-race inside diameter between the rollers.		One piece, broached pockets, located on outer-race flanges.		One piece, broached pockets, located on outer-race flanges.		One piece, broached pockets, located on outer-race flanges.		One piece, broached pockets, located on outer-race flanges.	
Total running time, hr.....	0	25.9	0	25.1	0	21.9	0	23.7	0	29.7	0	23.2	0	22.5	0	26.1	0	22.8
Average roller diameter, in....	0.5511	0.5505	0.5511	0.5506	0.5511	0.5509	0.5510	0.5509	0.5512	0.5510	0.5511	0.5501	0.5511	0.5500	0.5511	0.5505	0.5511	0.5510
Average roller length, in.....	0.5507	0.5505	0.5508	0.5506	0.5507	0.5505	0.5506	0.5505	0.5508	0.5506	0.5507	0.5500	0.5508	0.5500	0.5507	0.5502	0.5508	0.5506
Total roller diametral variation, in.	4.8×10 ⁻³		5×10 ⁻³		5×10 ⁻³		5×10 ⁻³		5×10 ⁻³		5×10 ⁻³		5×10 ⁻³		5×10 ⁻³		5×10 ⁻³	
Total roller-length variation, in.	0.0004		0.00015		0.00045		0.0002		0.0003		0.0004		0.0004		0.0004		0.0004	
Axial clearance between roller and race flanges, in.	0.0025	0.0035	0.0021	0.0043	0.0022	0.0037	0.0026	0.0047	0.0028	0.0044	0.0022	0.0038	0.0020	0.0039	0.0019	0.0020	0.0018	0.0021
Axial clearance between roller and cage, in.	0.012	0.013	0.0065	0.007	0.006	0.0065	0.007	0.007	0.0065	0.0065	0.012	0.012	0.012	0.012	0.012	0.012	0.012	0.012
Circumferential clearance between roller and cage, in.	0.011	0.015	0.011	0.0145	0.006	0.010	0.009	0.0105	0.013	0.014	0.0115	0.051	0.0115	0.051	0.010	0.0115	0.011	0.012
Mounted bearing: Diametral clearance, in. Bearing.....	0.001	0.0012	0.0009	0.0014	0.0011	0.0017	0.0008	0.0013	0.0005	0.001	0.0010	0.0030	0.0009	0.0033	0.0008	0.0027	0.0011	0.0015
..... Cage.....	.014	.0145	.008	.0085	.009	.009	.008	.014	0.075	.008	.0205	.0225	.0205	.0225	.019	.019	.0205	.0205
Eccentricity, in.....	0.0001	0.0002	0.0001	0.0002	0.0001	0.0002	b	0.0008	0.0001	0.0002	0.0001	0.0003	0.0001	0.0006	0.0002	0.0003	0.0001	0.0003
Remarks.....	Heavy wear on roller ends and inner-race flange faces.		Heavy wear in cage-roller pockets and on rollers. Good high-speed operation.		Wear of all parts light. Best performance of all bearings at very high speeds.		Heavy wear on outer-race inside diameter and cage outside diameter.		Heavy wear in cage-roller pockets. Vibration at high speeds.		Inner-race roller track frosted because of cage slip and polished in non-frosted areas. Outer-race roller track and cage-locating surface polished. Roller and cage wear very severe.		Inner-race roller track frosted because of cage slip and polished in non-frosted areas. Outer-race roller track appeared dull. Roller and cage wear very severe.		Inner-race roller track frosted because of cage slip; outer-race unmarked. Cage wear light. Roller wear fairly heavy on periphery and ends.		No inner-race frosting after low- and high-speed tests. Outer-race unmarked. Cage wear very light. Roller wear light. Severe inner-race frosting and slight surface galling after slip tests.	

^a Values obtained after high-speed tests and before cage-slip tests.

TABLE III.—TEST-BEARING-HARDNESS MEASUREMENTS^a

Bearing.....	A		B		C		D		E		F		G		H		I	
	Before	After	Before	After	Before	After	Before	After	Before	After	Before	After	Before	After	Before	After	Before	After ^b
Cage material.....	Nodular iron		Nodular iron		Nodular iron		Nodular iron		Nodular iron		Nodular iron		Nodular iron		Bronze		Bronze	
Outer-race face (Rockwell C-scale).....	59.5-61	59.5-60.5	60	60-61.5	60	60.5-62	60-61	59-60.5	60-61	60-60.5	61-62	59-61	60-61	60-61	60.5-62	58-60	58.5-60	58-60
Inner-race face (Rockwell C-scale).....	59-60	60-61	60	60-61.5	61	61-61.5	62	60-61	61-62	60-60.5	62	60-61	60-62	60-61	59-59.5	58.5-59.5	61-62.5	60-61
Roller end (Rockwell O-scale).....	65-65.5	63-65	65	63-63.5	65	63-64 ^a	64-66	64.5-66	65	64-65.5	63-65	61-63	63-66	62-64	63-66	62-63.5	63-65.5	62-63
Cage face (Rockwell B-scale).....	96	93-95	93	92-96	93	95-98	93	93	93	91-93	97	92-95	98	93-96	60-65	58-62	61-65	59-62

^a Obtained with Rockwell superficial hardness tester.

^b Obtained after high-speed tests but before cage-slip tests.

TABLE IV.—TEST-BEARING SURFACE-FINISH MEASUREMENTS *

Bearing.....	A		B		C		D		E		F		G		H		I	
	Nodular iron		Nodular iron		Nodular iron		Nodular iron		Nodular iron		Nodular iron		Nodular iron		Bronze		Bronze	
	Before	After	Before	After	Before	After	Before	After	Before	After	Before	After	Before	After	Before	After	Before	After ^b
Cage material.....	1.5-3	2-4	4	5-14	4	1.5-3	2-4	2-3	2-4	2-3	2-3.5	2.5-20	2-3	2.5-20	2.5-4	8-20	2-3	5-20
Inner-race roller-riding diameter, circumferential.....	1.5-3	2-4	4	5-14	4	1.5-3	2-4	2-3	2-4	2-3	2-3.5	2.5-20	2-3	2.5-20	2.5-4	8-20	2-3	5-20
Roller diameter, axial.....	2-4	2-6	2-4	2-4	3	1.5-3	1.5-3.5	1.5-3.5	3-4	1.5-3.5	3-4.5	2-6	3-4.5	2-8	3-4	1.5-4	1.5-4.5	1.5-4.5
Roller end.....	2-3.5	2-4	3-4	3-8	3-4	3-7	3-4	2-15	3-4	2-16	3-4	1.5-10	3-4	1.5-12	2-3.5	1.5-3	3-4	1.5-4
Cage-locating surface, circumferential.....	3-5	3-5	3-5	8-12	4-6	2-4	3-4	2-5	3-5	3-6	3-5	2-5	3-5	1.5-4	3-5	1.5-4	2-4	2-3.5
Outer-race roller-riding diameter, circumferential.....	3-4	2-3.5	3-5	4-8	4-6	1.5-2.5	3-4	2-5	3-5	3-6	3-5	1.5-4	3-4	2-6.5	3-4.5	2-4	2-4	2-3.5
Cage, locating diameter.....	14-26	10-18	15-20	10-20	15-20	10-20	15-20	3-6	15-20	3-6	10-16	15-20	10-15	15-20	20-25	20-30	20-25	20-30

^a Measured in micrometers, rms with profilometer.
^b Obtained after high-speed tests but before cage-slip tests.

TABLE V.—TEST-BEARING-WEAR DATA *

(a) Low-speed tests.

Bearing.....	F	G	H	I
Cage material.....	Nodular iron	Nodular iron	Bronze	Bronze
Outer-race wear, mg.....	17	23	16	5
Inner-race wear, mg.....	5	1	7	2
Roller wear, mg.....	28	67	68	23
Cage wear, mg.....	37	51	18	13

(b) High-speed tests.

Bearing.....	F	G	H	I
Cage material.....	Nodular iron	Nodular iron	Bronze	Bronze
Outer-race wear, mg.....	248	515	69	4
Inner-race wear, mg.....	25	34	23	10
Roller wear, mg.....	1744	1882	883	48
Cage wear, mg.....	6233	8913	30	18

* Measured by weight loss.

TABLE VI.—WEAR DATA FOR CAGE-SLIP INVESTIGATION WITH TEST BEARING I *

[Conditions for each test: time, 4 hr; DN, 1.2×10⁸ (16,000 rpm); oil flow, 2.75 lb/mtn; oil inlet temperature, 100° F.]

Test	Load, lb	Average cage slip, percent	Wear, mg			
			Outer race	Inner race	Rollers	Cage
1.....	368	2	3	-1	3	6
2.....	113	30	4	10	3	6
3.....	7	95	7	132	1762	49

* Measured by weight loss.

