

## REPORT No. 535

# HYDROGEN AS AN AUXILIARY FUEL IN COMPRESSION-IGNITION ENGINES

By HAROLD C. GERRISH and HAMPTON H. FOSTER

### SUMMARY

*An investigation was made to determine whether a sufficient amount of hydrogen could be efficiently burned in a compression-ignition engine to compensate for the increase of lift of an airship due to the consumption of the fuel oil. The performance of a single-cylinder four-stroke-cycle compression-ignition engine operating on fuel oil alone was compared with its performance when various quantities of hydrogen were inducted with the inlet air. Engine-performance data, indicator cards, and exhaust-gas samples were obtained for each change in engine-operating condition.*

*Hydrogen could be burned satisfactorily at all loads up to and including cruising at compression ratios of 13.4 and 15.6 in sufficient quantities to compensate for the increase in lift due to the consumption of the fuel oil. In the cruising range the mixtures of fuel oil and hydrogen burned as efficiently as the fuel oil alone. At small power outputs, the mixture of fuel oil and hydrogen burned less efficiently than the fuel oil alone; whereas, for power outputs greater than that required for cruising, the mixtures of fuel oil and hydrogen burned more efficiently than the fuel oil alone.*

*For all loads except idling there was present in the exhaust water vapor weighing more than the fuel oil burned, approximately 25 percent more for all loads above cruising. When burning the maximum usable amount of hydrogen along with the fuel oil, the weight of water vapor was 80 percent more at full load and 200 percent more at small loads.*

*The engine always stopped firing when the fuel oil was cut off. Throughout the limits of the test conditions, it was never possible to auto-ignite the various mixtures of hydrogen and air but the injection of even a minute quantity of fuel oil would cause the mixtures to burn. The engine showed no ill effects from the use of hydrogen and no change in engine operation was apparent.*

### INTRODUCTION

The most economical attitude for airship flight is at zero angle of pitch. If the static equilibrium of an airship is not maintained during flight the airship must be operated at either a positive or a negative angle of pitch to maintain constant altitude. Any flight atti-

tude other than zero angle of pitch results in an increase in drag; hence more power and greater fuel consumption are required for an equivalent speed. In addition, the hazards of handling an airship are greater when it is not in static equilibrium.

The static equilibrium of an airship can be maintained during flight by valving the lifting gas, by recovering water from the exhaust gas, or by using a fuel having a density nearly equal to that of air. The valving of helium is not an attractive method because of the relatively high cost of this gas; the valving of hydrogen is, however, relatively inexpensive. The use of a water-recovery apparatus results in increased weight, added drag, and greater fuel consumption. With present spark-ignition engines the use of a fuel having a density nearly equal to that of air is the most promising method of maintaining the equilibrium of airships in flight (reference 1).

The burning of the excess hydrogen in compression-ignition airship engines instead of valving it would be particularly advantageous because the hydrogen required to lift a given weight of fuel oil contains a quantity of heat energy equal to 21.5 percent of the heat energy of the liquid fuel. If the hydrogen can be burned with the same efficiency as the liquid fuel, the required weight of fuel would be reduced 17.6 percent and a proportional increase in payload would be possible.

The induction of the hydrogen with the inlet air would not be feasible with a two-stroke-cycle compression-ignition engine on account of the loss of hydrogen and the probability of pre-ignition of the hydrogen-air mixture by the hot exhaust gases during the scavenging process. Possibly an injection system could be used to supply the necessary hydrogen during the compression stroke. In this case the hydrogen should be injected immediately after the exhaust valve closes so that the hydrogen will have as long a time as possible to mix with the air. Injection of the hydrogen near the end of the compression stroke would require a multistage compressor whose great weight would be undesirable for airships.

If the hydrogen could be burned in four-stroke-cycle compression-ignition engines the airship would have the

advantage of better fuel economy maintained over a wide range of engine speeds and loads. Mucklow (reference 2) has successfully burned hydrogen with fuel oil in a single-cylinder compression-ignition engine having a compression ratio of 10.3 and operating at 210 revolutions per minute. The maximum quantity of hydrogen used was 3 percent of the inducted air and was sufficient to compensate for the fuel used at low-power outputs. Helmore and Stokes (reference 3) attempted to burn pure hydrogen in a single-cylinder compression-ignition engine having a compression ratio of 11.6 and operating at 1,000 revolutions per minute. On account of violent detonation at nine-tenths and at full power the tests had to be abandoned.

of hydrogen and fuel oil, and the suitability of exhaust gases for water recovery.

#### APPARATUS

Figure 1 is a photograph of the test unit with the auxiliary equipment required for supplying a controlled flow of hydrogen. The engine is a single-cylinder four-stroke-cycle compression-ignition test engine (5-inch bore and 7-inch stroke) having a vertical disk form of combustion chamber. (See fig. 2.) The compression ratio was changed during the preliminary tests by raising or lowering the cylinder head; during the main tests, it was changed by inserting different spacers between the cylinder and the cylinder head so that

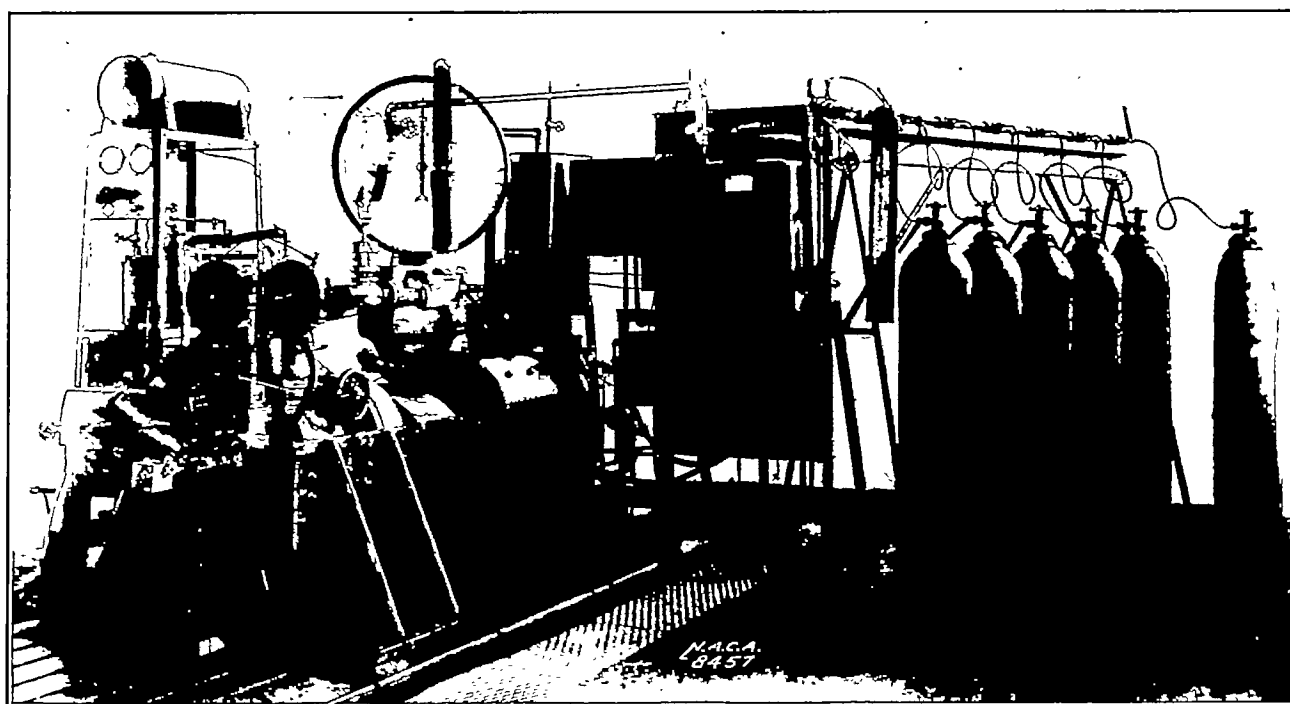

FIGURE 1.—The single-cylinder test engine and auxiliary equipment.

When using a mixture of 90 percent hydrogen and 10 percent "oil gas" in conjunction with fuel oil in the same engine, they were, however, able without pre-ignition to exceed the aerostatic equivalent of the fuel oil burned. The aerostatic equivalent of the fuel oil burned is the quantity of lifting gas that must be either valved or burned to compensate for the decrease in gross weight of the airship resulting from the burning of the liquid fuel.

On account of the lack of knowledge concerning the use of hydrogen in compression-ignition engines in sufficient quantities to maintain the static equilibrium of an airship at all engine outputs, the National Advisory Committee for Aeronautics investigated this problem. The Committee was particularly interested in the quantity of hydrogen that could be burned in a compression-ignition engine when inducted with the inlet air, the combustion characteristics of mixtures

the general shape of the combustion chambers for the 13.4 and 15.6 compression ratios would be similar. The spring-loaded fuel-injection valve had a six-orifice nozzle and was hydraulically operated by a cam-actuated plunger pump. The commercial grade of fuel oil used had a specific gravity of 0.847 and a viscosity of 41 seconds Saybolt Universal at 80° F.

The part of the test apparatus that differed from a conventional arrangement was the induction system through which the air and hydrogen were supplied to the engine. The air was measured by a 100-cubic-foot gasometer and then passed through two surge chambers and appropriate piping to the hydrogen-air mixing valve. The hydrogen was obtained from five high-pressure bottles connected to a manifold. From this high-pressure manifold the hydrogen passed through a reducing valve to a commercial gas meter (rated capacity 375 cubic feet per hour) and then through a pack-

type flame arrester to the mixing valve. The pressure at the gasmeter inlet was maintained at atmospheric by manual control of the reducing valve. The photograph of the apparatus (fig. 1) shows the water manometer and thermometer for measuring the pressure and temperature of the hydrogen and also the connection provided for extracting hydrogen samples during the tests.

In the preliminary set-up the hydrogen was piped directly to the mixing valve but the pressure pulsa-

ing the system before stopping the engine is shown at the extreme end of the high-pressure manifold.

The hydrogen-air mixing valve shown in figure 3 was obtained from the Bureau of Standards and was used without alteration except for the addition of the flame arrester at the entrance of the hydrogen tube. The hydrogen entered through the flame arrester and filled the annular space about the main venturi passage. Connection between the annular space and the main passage was accomplished by

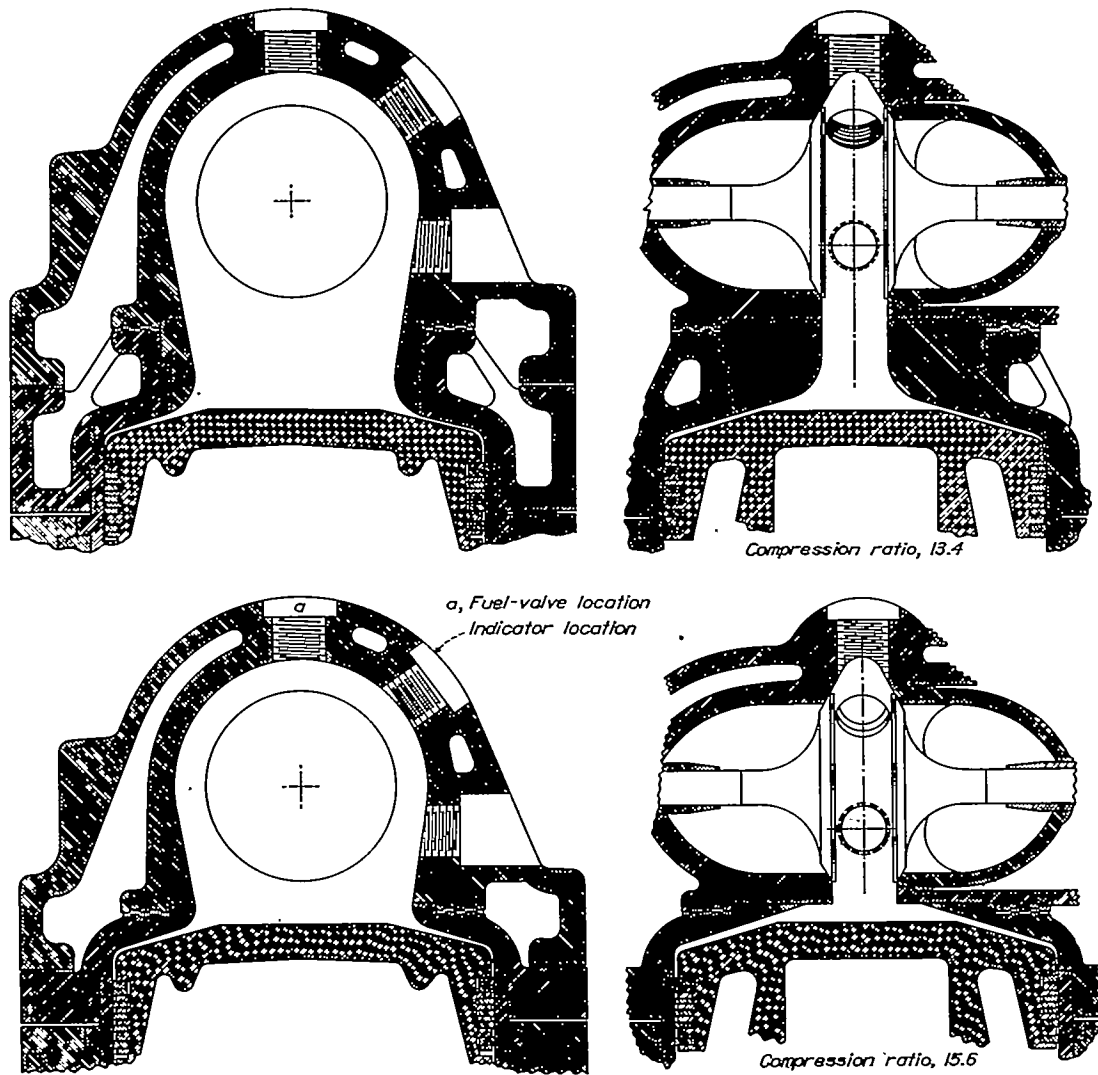

FIGURE 2.—Combustion chambers used with compression-ignition engine.

tions in the induction system of the single-cylinder test engine made the action of the gas meter erratic. The pulsations were satisfactorily damped by placing a 12-inch diameter surge chamber with a thin rubber diaphragm between the gas meter and the mixing valve. (See fig. 1.) The high-pressure hydrogen bottles are shown near the engine but, during the tests, the pipe connecting the surge tank and the gas meter was extended so that the bottles and the meter were outside the building. The CO<sub>2</sub> bottle used for flush-

turning the adjusting sleeve so that the two parts of the venturi separated. This separation allowed the hydrogen to flow in and mix with the inlet air in quantities determined by the amount of rotation of the adjusting sleeve. The mixing valve was placed as close to the engine as possible to keep the volume of hydrogen-air mixture to a minimum. The mixing valve and the necessary piping reduced the volumetric efficiency and therefore the normal output of the engine; but, as the investigation was concerned only

with comparative data, this point is relatively unimportant.

The cylinder pressure was measured both with the balanced-diaphragm type of maximum cylinder pressure indicator (reference 4) and with the Farnboro indicator. The Farnboro indicator was also used in obtaining the indicator cards. A modified Bureau of Mines type of gas-analysis apparatus (reference 5) was used in analyzing the exhaust-gas samples. The exhaust-gas temperature was measured by means of a calibrated thermocouple.

All instruments used in connection with these tests were calibrated and corrections to observed data have been made where necessary. Special care was taken to insure the accuracy of the hydrogen quantities, the hydrogen meter being calibrated before, during, and after the tests and found to read within  $\pm 1$  percent of the correct value at all times. Analysis of the hydrogen samples taken at different times during the tests showed an average purity of 98.4 percent and all hydrogen quantities have been corrected on this basis.

#### METHOD

Preliminary engine runs were made at compression ratios of 13.4 and 15.6 and indicator cards were taken with a modified Farnboro indicator at varying injection advance angles to determine the timing at which the pressure rise, indicating combustion, in the cylinder would start at top center. At the test speed of 1,500 revolutions per minute the required injection advance angles were found to be  $12^\circ$  before top center for the 13.4 compression ratio and  $10^\circ$  for the 15.6 compression ratio. These injection advance angles were used throughout the tests.

The majority of the test runs were made with the amount of hydrogen as the variable. The engine was brought to stable operating conditions on fuel oil alone with the injection-pump controls set for the fuel quantity desired. After the engine-performance data, exhaust-gas sample, and indicator card had been obtained for the fuel oil alone, the hydrogen flow was started and the amount used was controlled by adjusting the mixing valve. Similar data were taken for each change in hydrogen quantity until the maximum usable amount of hydrogen was reached.

The maximum usable amount of hydrogen varied with the operating conditions (as will be discussed later) and no test runs were attempted with more than that amount. Although no endurance runs were made, a series of tests often lasted more than 3 hours without any apparent difference in engine operation or performance.

Test runs were made for seven different fuel-oil quantities at each compression ratio except that no hydrogen was added at the largest fuel quantity for

the 15.6 compression ratio. The fuel-oil quantities ranged from approximately 1 to  $3.5 \times 10^{-4}$  pounds per cycle (excess-air coefficients 3.2 to 0.9, respectively) and the hydrogen quantities varied from 0 to 10 percent of the inlet air by volume. Unless otherwise stated, "percent hydrogen" is the percentage by volume of inlet air.

Tests were made to determine the heat losses to the cooling water at a compression ratio of 15.6 with fuel oil alone and also with fuel oil and the corresponding amount of hydrogen to maintain equilibrium, or constant-lift, conditions. These heat-dissipation tests did not show enough difference to justify similar tests at the 13.4 compression ratio.

An additional series of tests was made at both compression ratios using various quantities of hydrogen

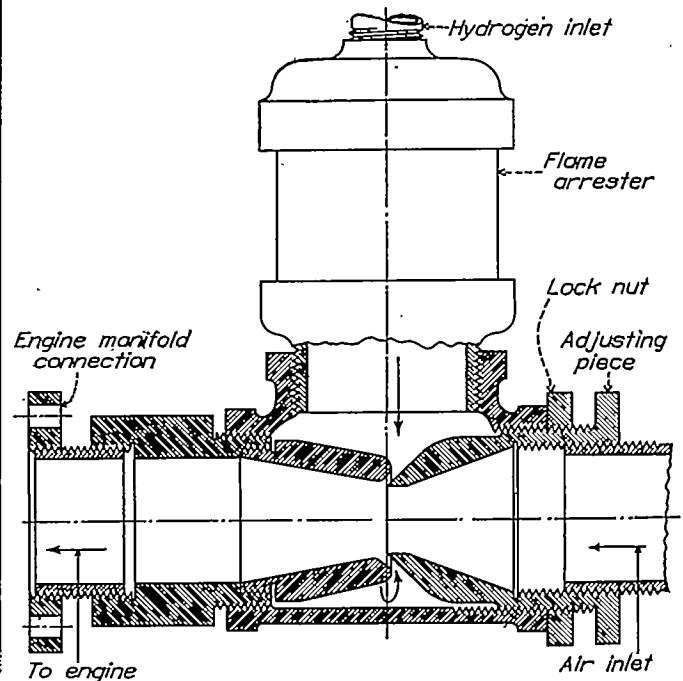

FIGURE 3.—Mixing-valve assembly.

and only a very small quantity of fuel oil for ignition of the hydrogen. These runs were made to study the combustion of the hydrogen when comparatively unaffected by the presence of the fuel oil and also to furnish data on the extreme conditions under which the lift of an airship could be reduced. The fuel-oil quantity used for these runs being too small to permit an accurate determination on the fuel scales, the reduction in torque obtained when injecting the fuel was first determined and then, from a curve of indicated mean effective pressure against fuel quantity, the amount of fuel was estimated. The value of  $7.0 \times 10^{-6}$  pounds per cycle obtained by this method is more than sufficient to insure consistent pump operation and produce regular flashes in the combustion chamber as observed through a small quartz window.

RESULTS AND DISCUSSION

ENGINE PERFORMANCE

The effect of adding various quantities of hydrogen to the inlet air on the performance of a single-cylinder compression-ignition engine operating on different quantities of fuel oil and at an engine speed of 1,500 revolutions per minute is shown in figure 4 for two compression ratios. The first point on the left of each full line is for fuel oil alone; the other test points on each full line denote an equal fuel-oil quantity with the addition of various quantities of hydrogen, the amount of hydrogen being converted to equivalent fuel oil by dividing the hydrogen heat input (pounds of hydrogen times 52,800 British thermal units per pound) by the lower heating value of the fuel oil (18,300 British thermal units per pound). The dotted line was drawn through the test points for fuel oil alone. The end of each full line is the limit of satisfactory operation of the engine under these conditions.

"Full load" is defined as that quantity of fuel theoretically required to combine with all the oxygen present. With mixtures of hydrogen and fuel oil there would be different equivalent fuel-oil quantities satisfying this definition, not only on account of the difference in the quantity of air required by these fuels for complete combustion but also on account of the displacement of the inducted air by the hydrogen. Full load (no excess air) for the 13.4 compression ratio varies from 3.12 to  $3.25 \times 10^{-4}$  pounds of equivalent fuel oil per cycle, the former value being for  $2.48 \times 10^{-4}$  pounds of fuel oil plus 7 percent hydrogen, and the latter value being for fuel oil alone. For the 15.6 compression ratio the values are slightly less on account of the decreased volumetric efficiency. Cruising load is considered as approximately two-thirds full load.

With small quantities of fuel oil, the addition of hydrogen decreases the thermal efficiency to less than that obtained with an equivalent amount of fuel oil. As the quantity of fuel oil is increased, however, the difference in efficiency diminishes until finally a fuel-oil quantity is reached beyond which any addition of hydrogen results in a greater thermal efficiency than is possible with an equivalent amount of fuel oil.

The tests indicate that all combinations of hydrogen and fuel oil burn with the same, or a greater, efficiency than an equivalent amount of fuel oil except for the combinations of small amounts of fuel oil with small amounts of hydrogen. For such combinations the combustion of the fuel oil is limited to a small portion of the combustion chamber and it is probable that the concentrations of the hydrogen at the low temperatures prevailing in the cylinder is insufficient to propagate the flame.

These results show that when the conditions within the combustion chamber are conducive to propagation of the flame through the hydrogen-air mixture the composite fuel burns more efficiently than an equivalent

amount of fuel oil. This increase in efficiency is probably due to the high rate of reaction of the hydrogen tending to create higher temperatures during the early part of the combustion period, which accelerates the reaction of the fuel oil.

The addition of hydrogen to the engine did not appreciably alter the temperature of the exhaust gases at either compression ratio. The heat loss to the cooling water of the cylinder and the head, as shown in figure 4, did not change when burning hydrogen in conjunction with fuel oil. The resultant increase in power, economy, and maximum cylinder pressure above cruising load without change in heat loss and exhaust temperature indicates that the hydrogen probably burned during the first part of the combustion period.

Figure 5 shows the effect of hydrogen on the operation of the engine at various fuel-oil quantities from a minute quantity to approximately 10 percent more fuel oil than is theoretically necessary for complete utilization of all the air inducted. The full lines indicate approximately the maximum usable percentages of hydrogen for the different fuel-oil quantities.

The maximum usable hydrogen percentage is not definite according to the data recorded for the test points near the full lines, the engine being occasionally unstable and then, under apparently identical conditions, operating satisfactorily. At times the apparent limiting hydrogen percentage as indicated by the full lines could be exceeded. As slight changes in the adjustment of the hydrogen-regulating valve often caused pronounced changes in engine operation near the critical point, it is believed that this erratic condition was due to the lack of a sufficiently precise control of the hydrogen. In the course of the tests the reducing valve was overhauled twice and both times the seat was found to be in poor condition. The operation of the engine at the instant the hydrogen flow was increased to a point where the operation became unstable is particularly interesting. The characteristic sound of the engine changed to that of motoring—exceptionally smooth, no knock nor roughness—and simultaneously there was a large drop in speed and power and the needle of the gage indicating the maximum cylinder pressure showed large variations in pressure. If the fuel oil was not shut off or the flow of hydrogen decreased immediately, pre-ignition took place. Examination of an indicator card showed that combustion occurred on the compression stroke. The stage of combustion following that of pre-ignition has been indicated as "explosion" and means that the mixture of hydrogen and air pre-ignited before the inlet valve closed and was propagated into the induction system. This explosion caused no ill effects to the engine or auxiliary equipment on account of the small volume of inflammable gases between the engine cylinder and the mixing valve.

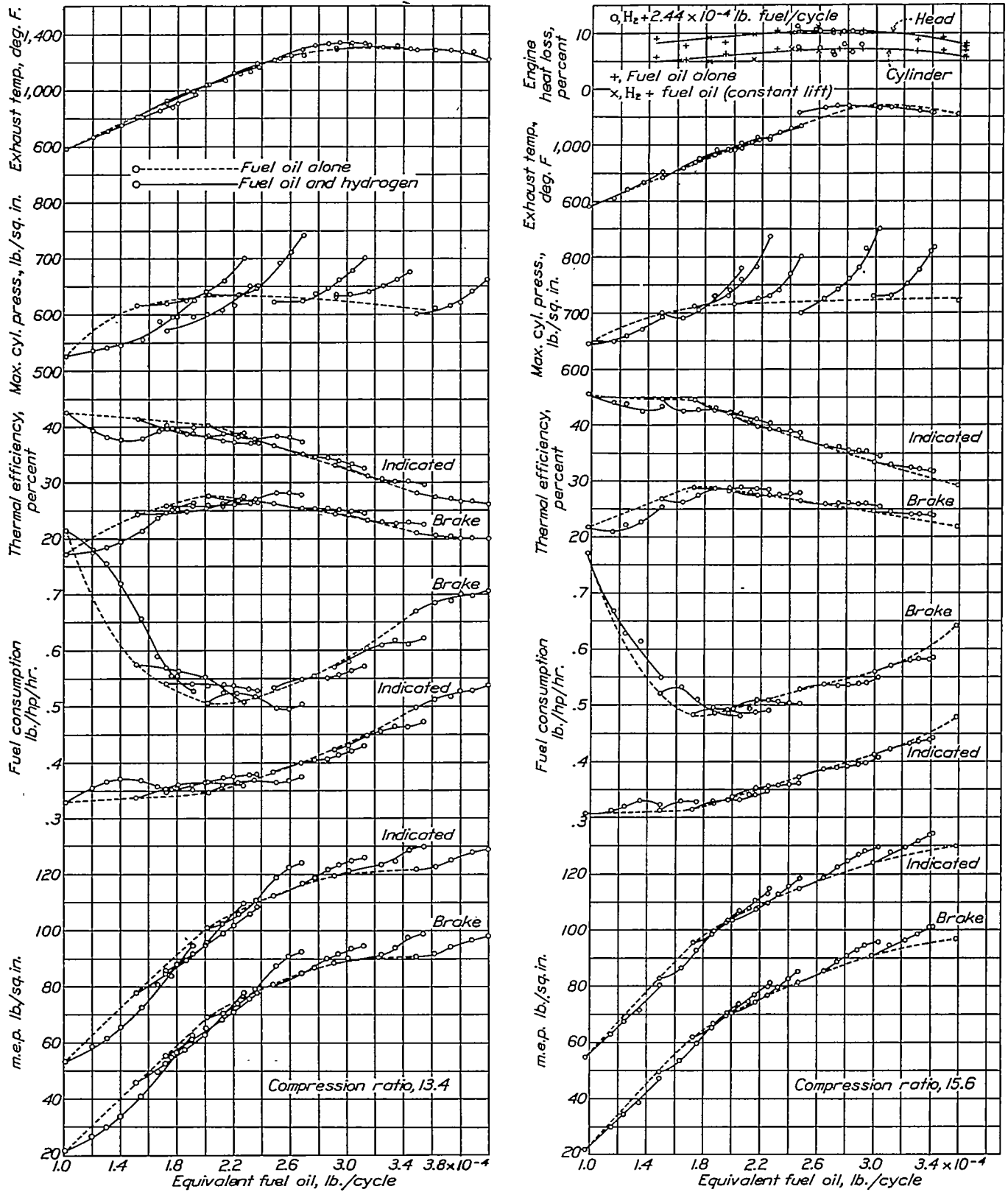

FIGURE 4.—Effect of hydrogen on engine performance.

All hydrogen-air mixtures below the maximum usable amount as shown by the full lines on the figure would not ignite without the injection of the fuel oil; when the fuel oil was shut off, the engine stopped firing. Any quantity of fuel oil, even exceedingly small ones, would cause the hydrogen to burn.

The curves show that the maximum quantity of hydrogen that can be inducted with the inlet air and satisfactorily burned in a compression-ignition engine decreases as the fuel-oil quantity and compression ratio increase, the amount varying from 14 to 7 percent by volume of the inducted air at a compression ratio of 13.4 and 12 to 5 percent at a compression ratio of 15.6.

The percentages of hydrogen that could be satisfactorily burned at the high engine loads are in agreement with those given by Mucklow (reference 2). With the compression ratios used in the present investigation the satisfactory operation of the engine with 14 percent of hydrogen at small engine loads was unexpected because Dixon (reference 2, p. 19) with an adiabatic-compression machine operating at a compression ratio of 10.6 exploded a 9.4-percent-by-volume mixture of hydrogen and air. In this machine "the gases were rapidly compressed in a well-lubricated, temperature-controlled cylinder and the piston then retained in the in-stroke position" (reference 6). The explosion of a 9.4-percent mixture of hydrogen in air by Dixon was most likely due to maintaining this mixture after compression at constant volume and thus exposing it to a high temperature for a long period of time. The ignition lag was very long, in fact even greater than the time required during the present tests to complete the entire power stroke. In order to obtain auto-ignition of hydrogen-air mixtures in the compression-ignition engine it was necessary not only to exceed the compression ratio indicated by Dixon but also to exceed the hydrogen-air ratio.

The dashed lines of figure 5 represent the aerostatic equivalent of the fuel oil consumed and their course shows that it was possible to burn hydrogen along with the fuel oil in quantities sufficient to maintain aerostatic equilibrium at all loads up to and including cruising load for both compression ratios, and that over a considerable power range it was possible to burn hydrogen in amounts either more or less than those required to maintain equilibrium. The allowable range of utilization of hydrogen when cruising would make it possible to increase or decrease the lift of the airship.

The effect of the addition of various amounts of hydrogen on the brake thermal efficiency and maxi-

imum cylinder pressure at several constant power outputs is shown in figure 6 for compression ratios of 13.4 and 15.6. For b. m. e. p.'s of 60 and 70 pounds per square inch at a compression ratio of 13.4, the efficiency is decreased by the addition of hydrogen and approaches a minimum at a hydrogen percentage of approximately 6 percent, which is in agreement with the trend found by Mucklow (reference 2). For a b. m. e. p. of 80 pounds per square inch the minimum value is reached at a hydrogen percentage of approximately 2; whereas the maximum efficiency is obtained at about 6 percent. For a b. m. e. p. of 90 pounds per square inch the efficiency increased with the amount of hydrogen added. Similar results are shown for compression ratio of 15.6 except that the hydrogen becomes effective at smaller percentages. The maxi-

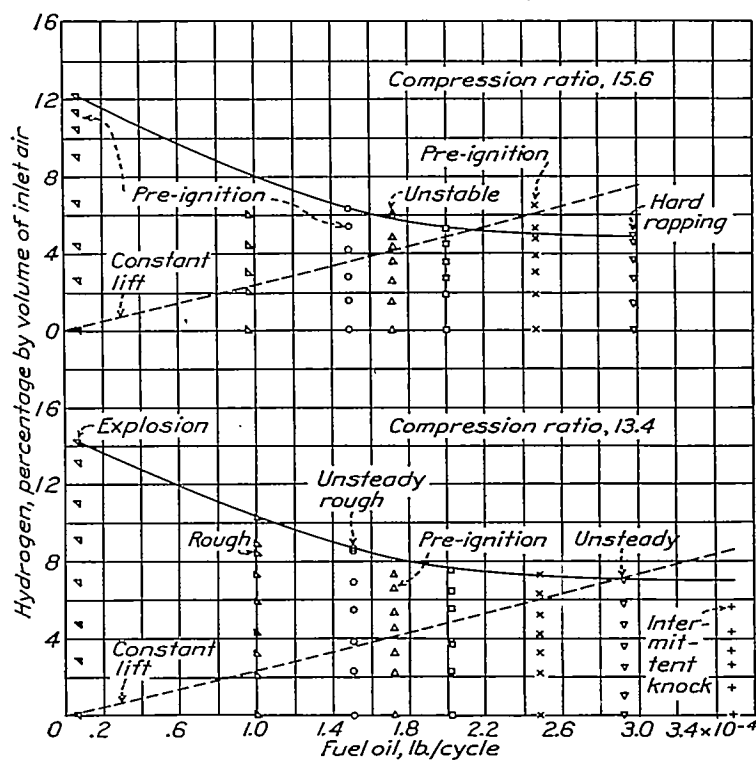

FIGURE 5.—Effect of hydrogen on engine operation. Engine operation was satisfactory unless otherwise specified.

imum cylinder pressure shows little change with brake mean effective pressure when operating with fuel oil but, as the hydrogen is added, the cylinder pressure increases and finally reaches a pressure approximately 75 pounds greater than that obtained with fuel oil alone for the same maximum output.

Figure 7 shows the effect of hydrogen on engine performance when the composite fuel is used, but only the weight of the fuel oil is taken into account in computing the specific fuel consumption. The dashed lines show the performance of the engine under conditions of constant lift obtained by the proper rates of consumption of the hydrogen and the fuel oil.

Figure 8 shows the comparative fuel consumptions at different power outputs under three assumed con-

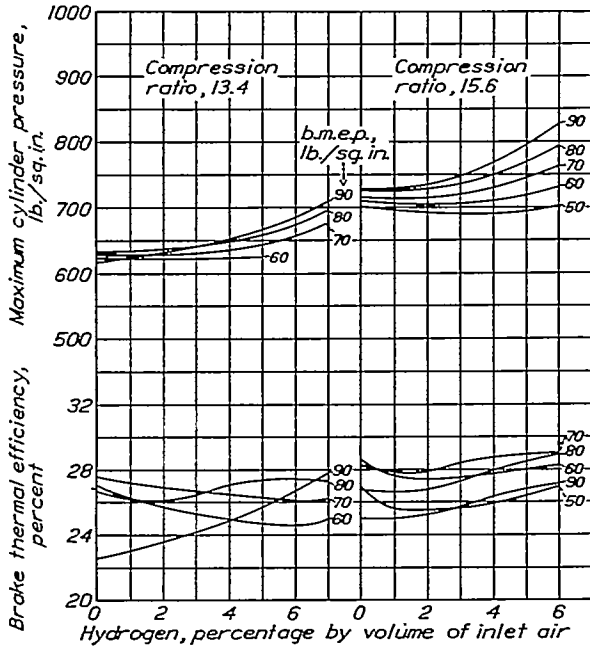

FIGURE 6.—The effect of hydrogen on engine operation for constant power.

ditions for compression ratios of 13.4 and 15.6. The dashed line shows the fuel consumption when fuel oil alone is used to produce power. For comparison

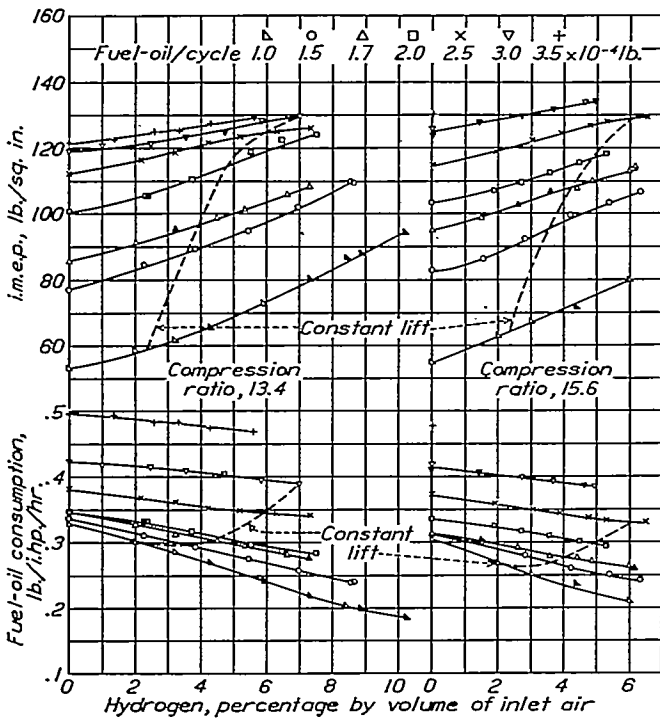

FIGURE 7.—Effect of hydrogen on engine performance. (Fuel-oil consumption based on actual fuel oil used.)

on a basis of equivalent heat input of fuel oil, the solid line shows the necessary consumption of the two fuels combined in the proper proportion to maintain a con-

dition of constant lift. The dot-dash line shows the consumption of the fuel oil for the constant-lift condition neglecting the weight of the hydrogen.

**COMBUSTION CHARACTERISTICS OF MIXTURES OF HYDROGEN AND FUEL OIL**

**Exhaust-gas analysis.**—The exhaust gases were analyzed to determine the causes of the effects noted. The percentages by volume of CO<sub>2</sub>, CO, O<sub>2</sub>, N<sub>2</sub>, H<sub>2</sub>O, H<sub>2</sub>, and CH<sub>4</sub> on the wet basis are plotted against

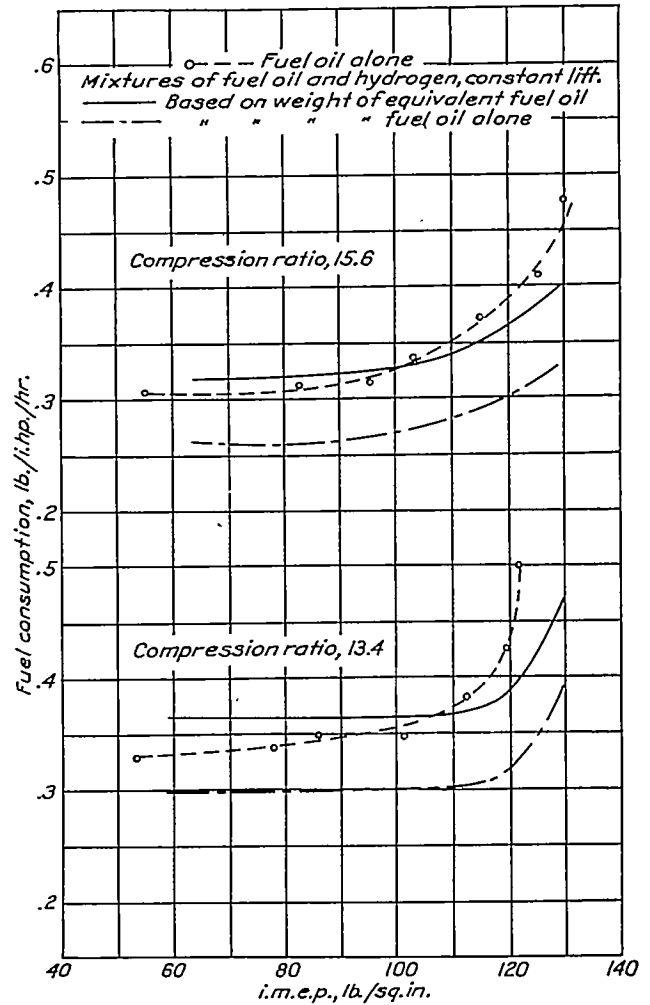

FIGURE 8.—Comparison of engine performance with different fuels.

equivalent fuel-oil quantity in figure 9 for compression ratios of 13.4 and 15.6. The first point at the left on each full line is for fuel oil alone and those to the right are for an equal fuel-oil quantity plus various amounts of hydrogen. The dashed line is drawn so as to connect all points for fuel oil alone. The results are placed on a wet basis to show the amount of water vapor present in the exhaust gases. The water vapor was determined from an "oxygen balance."

The curves of figure 9 show that the amount of water vapor formed in the exhaust increases linearly with the amount of hydrogen inducted and that the rate of formation is independent of compression ratio



and of fuel-oil quantity except in cases where the fuel present exceeds that required for utilization of all the oxygen.

Under normal operating conditions the water recoverable from the exhaust of a spark-ignition

the difference in saturation of the incoming air and exhaust gases. Figure 10 has been prepared to show the quantitative effect of various mixtures of hydrogen and fuel oil on the amount of water vapor formed in the exhaust. The effect of incomplete combustion has

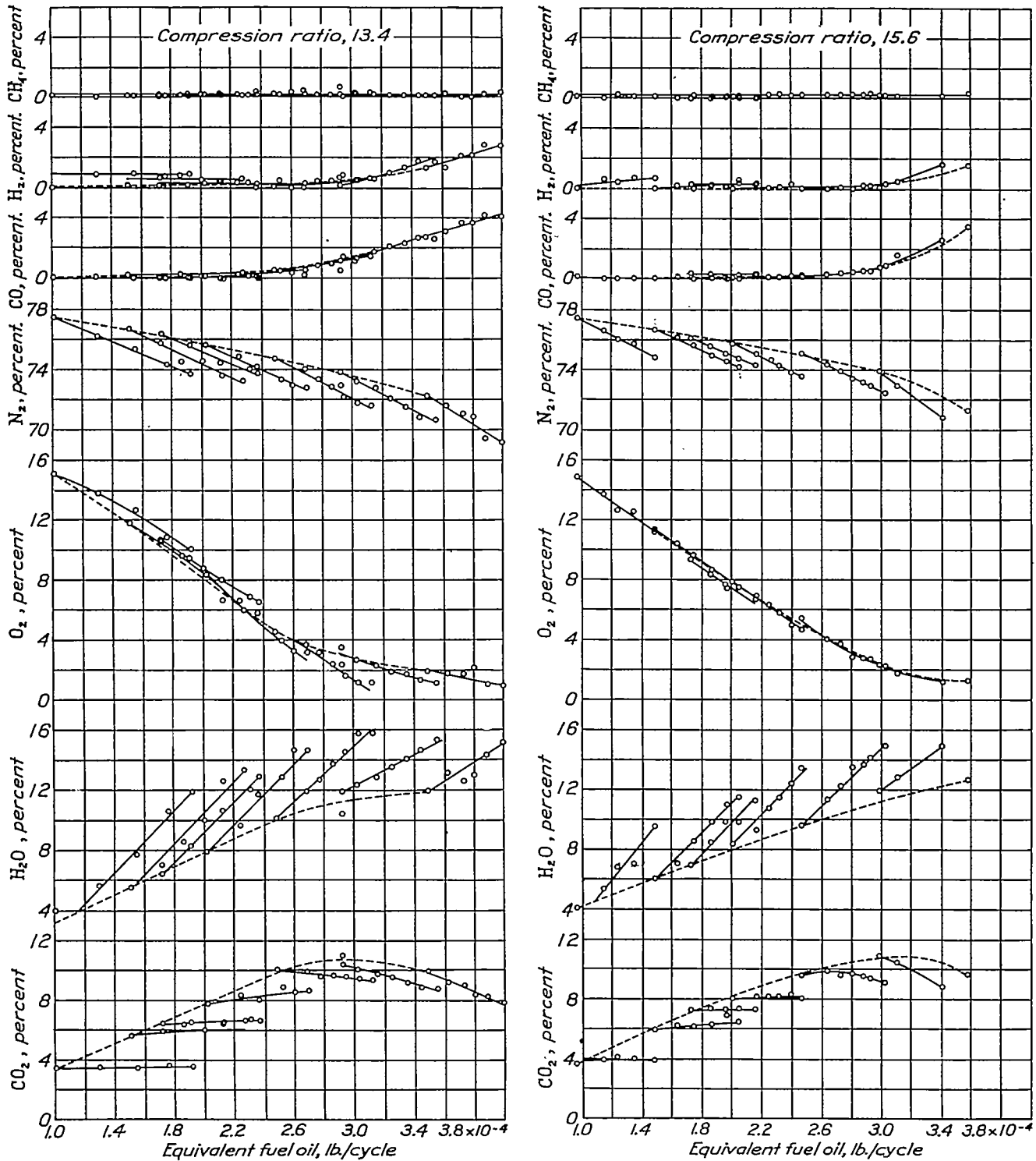

FIGURE 9.—Effect of hydrogen on exhaust-gas composition.

engine by the use of a highly efficient condenser system is approximately 90 to 100 percent of the weight of fuel burned (See reference 7.) The remainder is lost on account of incomplete combustion of the fuel and

been included, but the effect of the difference in saturation of the incoming air and the exhaust gases has been omitted because it varies with atmospheric conditions. The dashed line is for fuel oil alone; the diagonal lines

show the rapid increase in water vapor when the hydrogen is added to the intake air. The figure shows that for all loads except idling the water vapor present in the exhaust weighed more than the fuel oil burned, approximately 25 percent more for all loads above cruising. When burning the maximum

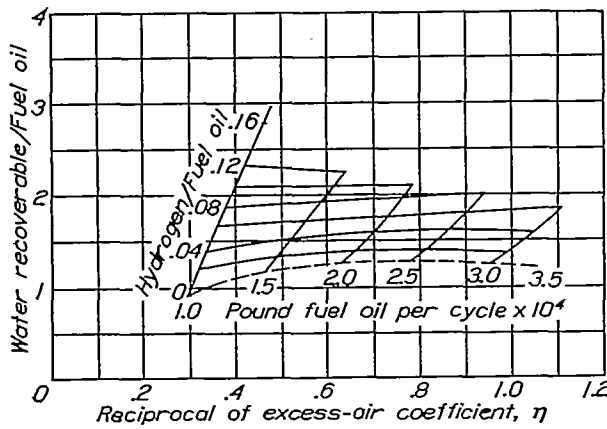

FIGURE 10.—Effect of load and hydrogen-fuel-oil ratio on water recoverable at a compression ratio of 15.6.

usable amount of hydrogen along with the fuel oil, the weight of the water vapor was 80 percent more at full load and 200 percent more at small loads.

Inasmuch as gasoline and fuel oil have approximately the same hydrogen content (reference 5), one would expect the water recovery from the exhaust of compression-ignition engines to compare favorably with that obtained from spark-ignition engines provided that the combustion efficiency and the quantity of air present are equal. Combustion efficiency is considered as the ratio of the heat liberated to the total available heat. Compression-ignition engines usually operate at a greater excess-air coefficient than spark-ignition engines and, according to Fulton (reference 7), this excess air would cause a greater amount of water vapor to be lost through its saturation. Considering the actual conditions under which the engines usually operate, the spark-ignition engine operating at the lower air-fuel ratio loses less water than compression-ignition engines through saturation but, owing to incompleteness of combustion, less water is formed. Exhaust-gas analyses from spark-ignition and compression-ignition engines when operating in their usual operating range show little difference in water recoverable, the amount of water available depending upon the air-fuel ratio, the temperature of the air inducted into the engine, and the temperature of the gases leaving the condenser.

Figure 11 has been prepared to show the effect of fuel quantity on combustion efficiency. This figure shows the completeness of combustion of the various combinations of fuel oil and hydrogen on a basis of air required for complete combustion. The curves for compression ratios of 13.4 and 15.6 show that the

combustion efficiency increased with fuel quantity up to an air excess of 50 percent but, when the air excess becomes less than 25 percent, the combustion efficiency decreases rapidly. It is apparent from these curves and those of indicated thermal efficiency shown in figure 4 that the improvement in indicated fuel consumption with fuel oil at small loads over that of other loads up to cruising is due to the improvement in cycle efficiency.

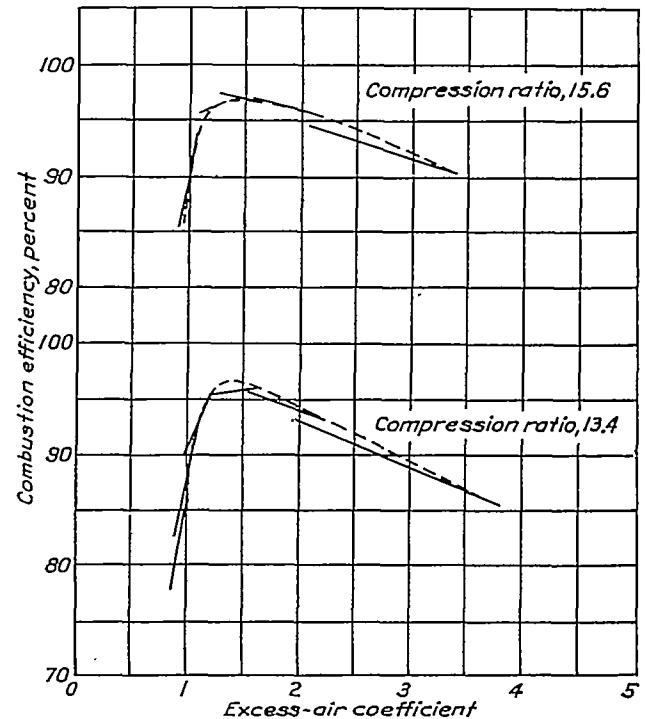

FIGURE 11.—Variation of combustion efficiency with excess-air coefficient.

**Analysis of indicator cards.**—The indicator cards taken during the power tests were used to obtain information concerning the evolution of heat in the combustion chamber. Figure 12 shows the pressure-time diagrams for six different fuel-oil quantities obtained at a compression ratio of 15.6, the broken lines being for fuel oil alone and the full lines for equal fuel-oil quantities with hydrogen added to the intake air. The curves show the corresponding amounts of fuel required to be effectively burned. By "effective fuel burned" is meant the combustion of the quantity of fuel required to produce the change in enthalpy (total heat) recorded on the indicator diagrams and does not include that dissipated as heat losses. In all cases the combustion pressures were higher and the areas of the cards greater with the composite fuel than with fuel oil alone.

A thermodynamic analysis of all the indicator cards taken during the power tests has been made and the results plotted in figure 13 to show the effective equivalent fuel oil burned up to 4°, 8°, 16°, and 30° after top center. The curves show that the addition of hydrogen with the smallest fuel-oil quantities is less

effective than an equivalent amount of fuel oil in raising the pressure in the combustion chamber and this effect is more pronounced at the lower compression ratio even though it is possible to utilize a greater amount of hydrogen. At  $4^\circ$  there is little difference between the curves for the fuel oil and for the composite fuel, indicating that the hydrogen plays little or no part in the ignition of the combustible mixture and has a negligible effect on the first part of the burning process. Mucklow (reference 2) found that the gas

combustion. The characteristic increase in slope of the lines for the composite fuel indicates that combustion is accelerated as the hydrogen-air ratio reaches the range of inflammability. The lower and upper limits of inflammability, according to Bone and Townend (reference 8), are approximately 4 and 71 percent, respectively, depending upon the temperature and pressure of the mixture.

Information concerning the combustion of small quantities of fuel oil and large quantities of hydrogen

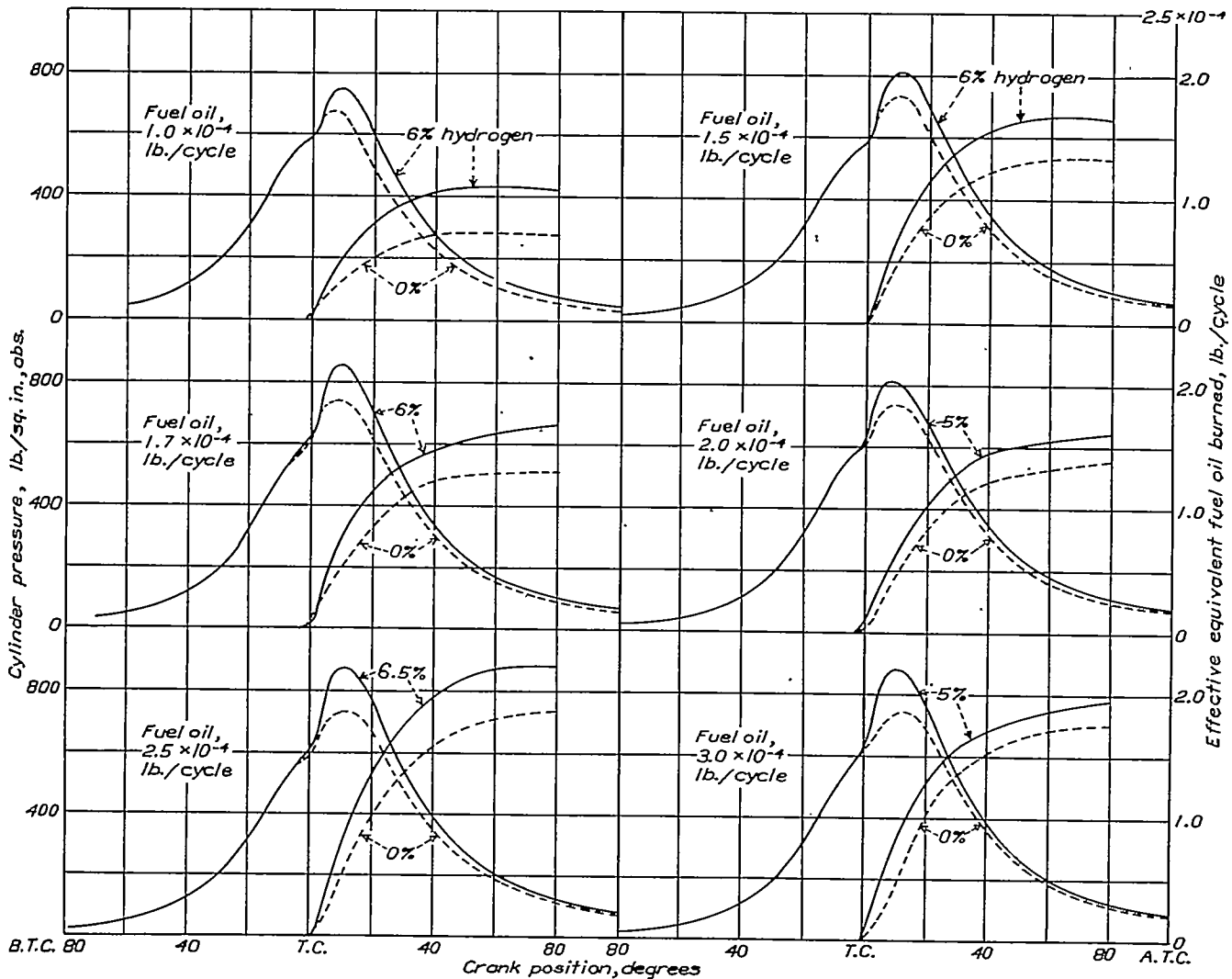

FIGURE 12.—Pressure-time diagrams for compression-ignition engine burning fuel oil and mixtures of fuel oil and hydrogen. Compression ratio, 15.6; Injection start  $10^\circ$  B. T. C.

had no effect on the point in the cycle where combustion begins; Helmore and Stokes (reference 3) found no need for altering the injection advance angle when hydrogen-cum-oil gas was used in conjunction with fuel oil.

The most noteworthy feature of the curves for the composite fuel is that in the cruising range the smaller additions of hydrogen are about as effective as an equivalent amount of fuel oil; larger amounts of hydrogen show a comparatively greater increase in effective

in a compression-ignition engine was obtained from tests using only enough fuel oil to ignite the hydrogen-air mixture. Figure 14 shows indicator cards taken when motoring the engine and when operating with the igniting charge of oil and with increasing amounts of hydrogen. The first diagram shows both compression and expansion pressures when the engine was motored; the others show the end of the compression line and most of the expansion line. The diagram following the motoring diagram was taken

with the igniting charge of oil and shows but slight difference from the motoring diagram. The diagrams with increasing amount of hydrogen show the scattering of pressure points, which indicates the irregularity of combustion from cycle to cycle that is usually associated with spark-ignition and carbureted mixtures.

The indicator diagrams of figure 14 and the curves resulting from their thermodynamic analysis, as well as those obtained at a compression ratio of 13.4 under similar conditions, are shown in figure 15. The analysis for both compression ratios shows that the period of burning (period from start to maximum amount burned) was increased by the addition of small quan-

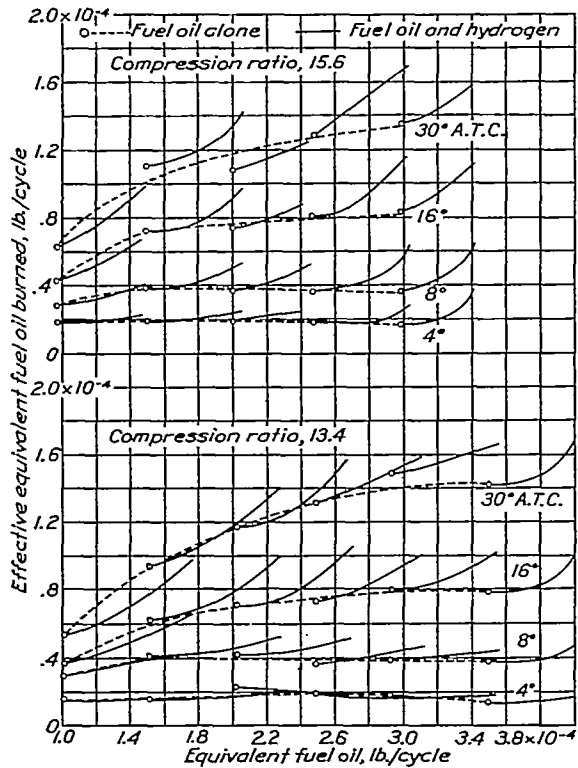

FIGURE 13.—Effect of hydrogen on combustion as deduced from indicator cards.

ties of hydrogen. For larger quantities (9 to 12 percent hydrogen for the 15.6 compression ratio and 9 to 14 percent for the 13.4 compression ratio) the period decreased and finally reached 40 crank degrees at the higher compression ratio and 60 crank degrees for the lower compression ratio. The reduction in the burning period with large quantities of hydrogen is opposite to the effect obtained with an increase in the fuel-oil quantity. (See fig. 12.) The change from slow to fast burning with increasing hydrogen is probably due to the change in mixture strength from below to within the range of inflammability. A similar effect is shown in figure 15 but, instead of a change in mixture strength, the range of inflammability was increased on account of the increase in temperature of the mixture (reference 8) with compression ratio. In the range of inflammability the combustion of the hydro-

gen-air mixture is similar to that with a carbureted mixture of gasoline and air in that combustion is completed early in the expansion stroke.

Figure 16 has been prepared to show the difference in the effective burning of hydrogen, fuel oil, and the composite fuel at the same total heat input equal to approximately one-third full-load (excess-air coefficient of 2.5 for the 13.4 compression ratio and 2.9 for the 15.6 compression ratio). The amounts of hydrogen in the composite fuel was 1.5 and 3 percent for the 15.6 and 13.4 compression ratio, respectively. The burning curves for hydrogen have been reproduced from figure 15 and the curves for fuel oil and the composite fuel have been obtained from a cross plot. The figure shows the same timing of the start of combustion for the three fuels and also approximately the same rate of burning at the start. At the higher compression ratio the hydrogen is more effective in raising the pressure throughout the entire burning period; at the lower compression ratio the combustion of the hydrogen lags behind that of the fuel oil for a considerable portion of the burning period. At both compression ratios, however, the total amount of heat evolved is greater for the hydrogen than for the fuel oil. The composite fuel is less effective at both compression ratios than either the hydrogen or the fuel oil in raising the pressure throughout the burning period. The difference is due to less fuel oil being injected and to the inefficient combustion of small amounts of hydrogen with small amounts of fuel oil, as has been previously discussed. Although it was impossible to burn very large quantities of hydrogen (over 14 percent) and thus make it possible to compare the rates of burning of the three fuels at larger loads, it is believed that at loads greater than cruising the effective-fuel-burned curves for the composite fuel will lie between that of hydrogen and that of fuel oil. (See fig. 13.)

### APPLICATION OF RESULTS

#### ADVANTAGES OF BURNING HYDROGEN IN AIRSHIP COMPRESSION-IGNITION ENGINES

From the results of these tests on a single-cylinder four-stroke-cycle compression-ignition engine operating at compression ratios of 13.4 and 15.6, it is concluded that hydrogen in sufficient quantities to maintain the static equilibrium of an airship can be satisfactorily burned along with the fuel oil at all loads up to and including cruising. For loads greater than cruising, the static equilibrium could be maintained only when operating at the lower compression ratio. Hydrogen could be burned in greater or less quantities than that of the aerostatic equivalent of the fuel oil burned, thus making a very adaptable system for controlling the buoyancy of the airship. The thermal efficiency for the combustion of the composite fuel was approximately the same as that for the fuel oil.

The burning of the hydrogen in the engines not only makes it possible to control the equilibrium of the airship but also makes it possible to reduce the quan-

the density of the mixture to increase with a resultant decrease in its lifting power and a greater quantity of mixture would be required to lift a given weight,

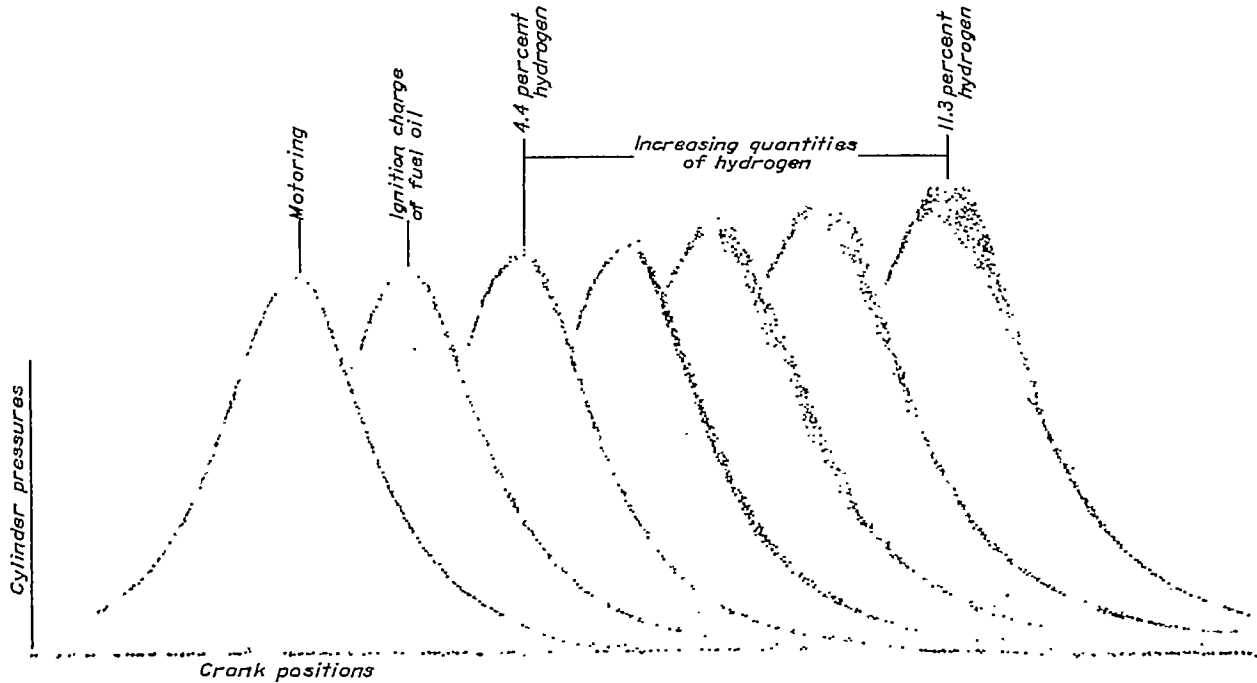

FIGURE 14.—Contact prints of indicator diagrams obtained with hydrogen-air mixtures. Compression ratio, 15.6; 0.000007 lb./cycle fuel oil used for ignition.

tity of fuel oil required for a given flight, increase the pay load carried, or increase the still-air range of the airship. It is interesting to determine the reduction

although the quantity of hydrogen present would be the same. Taking the specific weight of pure hydro-

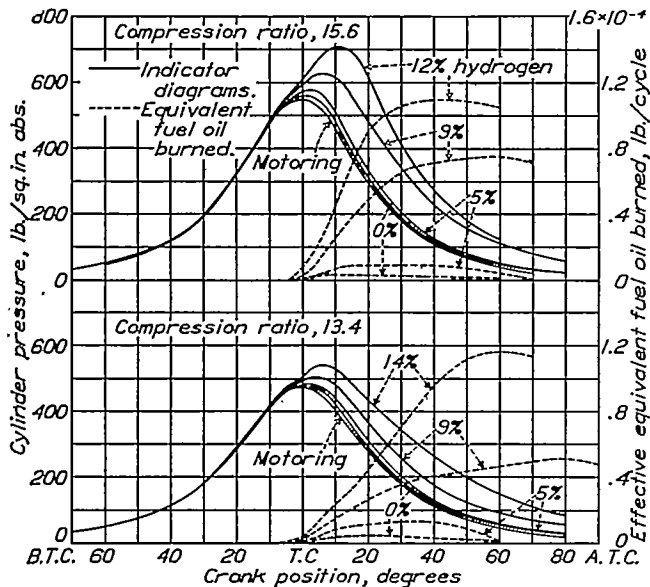

FIGURE 15.—The effect of hydrogen on combustion when 0.000007 lb./cycle of fuel oil is used for ignition.

in the quantity of fuel oil required for a flight when burning hydrogen in the engines instead of valving it to maintain static equilibrium. In this case it is only necessary to consider that the hydrogen is pure. Any impurity, such as air, in the hydrogen would cause

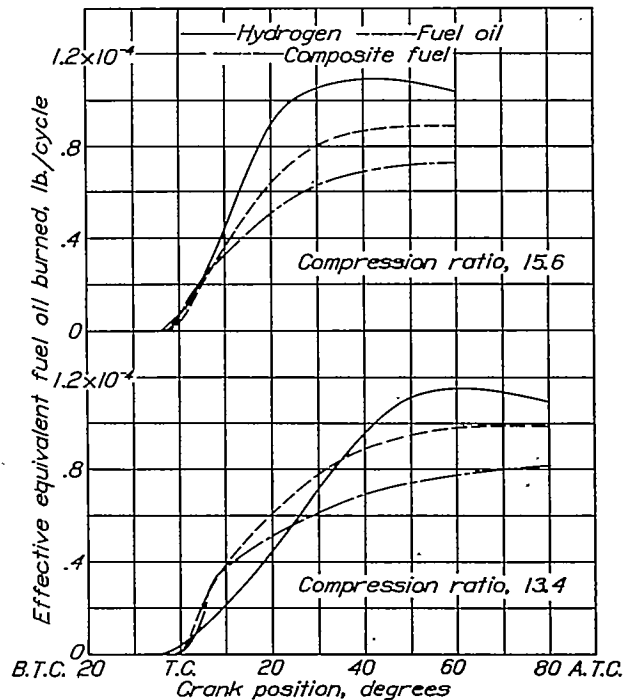

FIGURE 16.—Comparative combustion of hydrogen, fuel oil, and composite fuel with constant heat input.

gen and air as 0.0053 and 0.0763 pound per cubic foot, respectively, the lifting force will be the difference in these values, 0.0710 pound per cubic foot. The aero-

static equivalent  $x$  of 1 pound of fuel oil burned will be equal to the specific weight of pure hydrogen divided by the lifting force, or 0.0746 pound per pound of fuel oil.

As the fuel oil  $y$  required for the flight when burning hydrogen together with the fuel oil plus the fuel oil

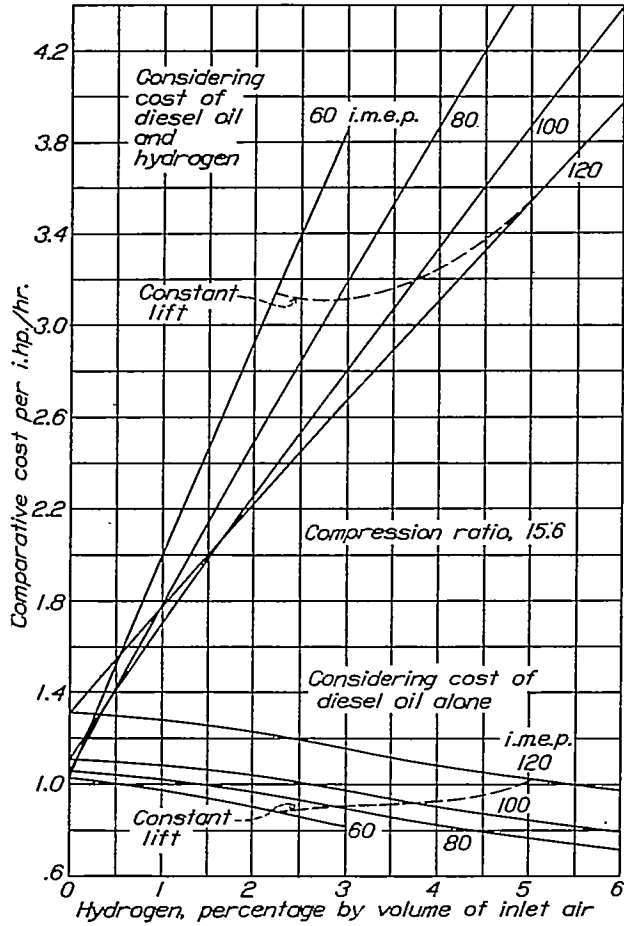

FIGURE 17.—Comparative cost of fuel oil and composite fuel.

equivalent of the hydrogen burned must equal the original quantity of fuel oil  $w$  required for the flight when valving the hydrogen:

$$y + \frac{52,800}{18,300} xy = w$$

$$y = 0.823w$$

where 52,800 and 18,300 are the heating values of hydrogen and fuel oil, respectively, in British thermal units per pound. It is seen from this computation that the burning of the hydrogen in the compression-ignition engines to maintain static equilibrium, instead

of valving it, results in a reduction of 17.6 percent for the weight of fuel oil required for the flight.

If the two fuels cost the same per heat unit, the full line in figure 8 would give an indication of the cost. These fuels vary considerably in their cost and figure 17 has therefore been prepared to show the comparative cost of power with the composite fuel on a basis of the actual cost. The figure shows that for constant lift with hydrogen at \$1.50 per thousand cubic feet and fuel oil at \$0.06 per gallon, the cost of power is tripled when the cost of hydrogen is included; but, when the hydrogen is considered as costing nothing, as would be the case for constant lift if it were burned instead of being valved, the cost of power would be decreased approximately 17 percent.

The pay load is an indication of the commercial value of an airship. It is interesting to determine how the pay load of an airship is affected by using different inflation gases and two types of engines. The following five arrangements have been taken for comparison and in each case the over-all dimensions, total gas volume, and total engine power are the same.

Airship A is assumed to be inflated with helium, to be fitted with spark-ignition engines burning gasoline, and to be fitted with water-recovery apparatus.

Airship B is assumed to be the same as airship A but to be fitted with compression-ignition engines.

Airship C is assumed to be fitted with dual gas cells: The outer cells are to be inflated with sufficient helium to support the fixed weight; the inner cells are to be inflated with hydrogen. The compression-ignition engines are assumed to burn hydrogen along with the fuel oil.

Airship D is assumed to be the same as airship A but to be inflated with hydrogen.

Airship E is assumed to be inflated with hydrogen and to be fitted with compression-ignition engines burning hydrogen along with the fuel oil.

It is further assumed that static equilibrium is maintained in all the airships by recovering water from the exhaust gases or by burning the hydrogen aerostatic equivalent of the fuel oil burned in the engine.

The information necessary to make a detailed tabulation of the weights of the various items in the airships is not available. The use of hydrogen in a secondary cell of airship C would, however, increase the weight of the gas cells and would also add some weight in the form of restraining and steadying suspensions. It would also be necessary to provide ducts

by which the hydrogen would be led to the engines. It should not be necessary to provide blowers to feed the hydrogen from the cells to the engines.

The water-recovery apparatus of airships A, B, and D not only increases the dead weight but also the drag. According to Fulton (reference 7) the weight of the water-recovery apparatus, bags, and piping of a 6,500,000 cubic-foot airship would be 16,000 pounds and, for a 6-day endurance flight, the increase in fuel consumption due to the increased drag would be approximately 9,000 pounds. For such a flight in freezing weather approximately 12,000 pounds of antifreeze material would also have to be carried.

The assumption that the dead weight of the five airships would be the same is believed to be in error only in making airships C and E somewhat heavier than they actually would be. In this assumption

the fuel tanks are considered to be the same for all airships and the weight-power ratio of the compression-ignition airship engine is considered to equal that of the spark-ignition airship engine.

The results of the computations are shown in the following table. It may be seen that airship E can carry approximately 80 percent more pay load than airship A; whereas airship C can carry 53 percent more pay load than airship A. If airship C attempts to compete commercially with airship E, it might obtain the more valuable pay load on account of the additional safety of the helium blanket and even with the handicap of 17 percent less pay load might be a greater commercial success. Airship B is the most desirable of the proposed types because of the decreased fire hazard but, owing to its small pay load, may be undesirable as a commercial airship.

**COMPARATIVE DATA FOR 5 AIRSHIPS HAVING THE SAME SIZE, SPEED, AND POWER BUT HAVING DIFFERENT INFLATION GASES AND USING DIFFERENT TYPES OF ENGINES**

[Normal gas volume, 95 percent full, 6,500,000 cubic feet; fixed weight, 221,000 pounds; speed, 80 miles per hour; power, 4,480 horsepower. Helium is assumed to have a lifting power of 0.062 pound per cubic foot and hydrogen a lifting power of 0.068 pound per cubic foot]

Airship	Volume of gas		Gross lift		Useful lift	Specific fuel consumption (liquid)	Fuel for 4,000-mile still-air range			Pay load (no fuel reserve)
	Helium	Hydrogen	Helium	Hydrogen			Gasoline (6.10 pounds per gallon)	Fuel oil (7.06 pounds per gallon)	Hydrogen	
	<i>Cubic feet</i>	<i>Cubic feet</i>	<i>Pounds</i>	<i>Pounds</i>	<i>Pounds</i>	<i>Pound per brake horsepower per hour</i>	<i>Pounds</i>	<i>Pounds</i>	<i>Cubic feet</i>	<i>Pounds</i>
A	6,500,000		403,000		182,000	0.45	101,000			81,000
B	6,500,000		403,000		182,000	.41		91,840		90,160
C	3,585,000	2,935,000	221,000	199,000	199,000	.41		75,600	1,064,000	124,000
D		6,500,000		442,000	221,000	.45	101,000			120,000
E		6,500,000		442,000	221,000	.41		75,600	1,064,000	145,400

If airship A carried liquid fuel in place of the pay load, it would be able to make a flight of approximately 7,200 miles; whereas airship C would be able to make a similar flight and, in addition, to carry approximately 63,000 pounds of pay load.

If airships A and C have the same disposable load, liquid-fuel load, and pay load, the one equipped with compression-ignition engines burning the aerostatic equivalent of the fuel oil burned will have a 33 percent greater still-air range. This increase in distance is due to the better fuel economy of the compression-ignition engine of 0.41 pound per brake horsepower hour compared with the 0.45 pound of the spark-ignition engine and to the burning of the hydrogen in the engines, which supplies an additional amount of energy equal to 21.5 percent of the fuel oil burned.

**CONCLUSIONS**

The investigation of the performance of a four-stroke cycle compression-ignition engine operating with various amounts of hydrogen added to the inducted air showed that:

1. It was impossible to auto-ignite hydrogen-air mixtures up to 12 percent hydrogen at compression

ratios of 13.4 and 15.6, although any quantity of fuel oil from 0.07 to  $3.5 \times 10^{-4}$  pounds per cycle would cause these mixtures to burn.

2. The engine could be stopped when burning the composite fuel by shutting off the fuel oil.

3. The maximum amount of hydrogen that could be burned satisfactorily decreased as the fuel-oil quantity and compression ratio increased, the maximum amount varying from 14 to 7 percent by volume of the inducted air at a compression ratio of 13.4 and 12 to 5 percent at a compression ratio of 15.6.

4. The brake thermal efficiency obtained with the composite fuel for all engine outputs up to that required for cruising (constant-lift conditions) was as much as 9 percent less than that obtained with fuel oil alone for the 13.4 compression ratio and 4 percent for the 15.6. For higher loadings the thermal efficiency with the composite fuel was greater than that obtained with fuel oil; the increase was as much as 19 percent for the 13.4 compression ratio and 13 percent for the 15.6 compression ratio.

5. The burning of mixtures of hydrogen and fuel oil at compression ratios of 13.4 and 15.6 should be an

efficient method of compensating for the decrease in weight of an airship due to the consumption of the fuel oil.

6. When the conditions within the combustion chamber were conducive to propagation of the flame through the hydrogen-air mixture the composite fuel burned more efficiently than an equivalent amount of fuel oil, i. e., the hydrogen burned during the early part of the combustion period.

7. The exhaust gases were particularly suitable for water recovery. For all loads except idling the water vapor present in the exhaust weighed more than the fuel oil burned, approximately 25 percent more for all loads above cruising. When burning the maximum usable amount of hydrogen along with the fuel oil, the weight of water vapor present was 80 percent more at full load and 200 percent more at small loads.

LANGLEY MEMORIAL AERONAUTICAL LABORATORY,  
NATIONAL ADVISORY COMMITTEE FOR AERONAUTICS,  
LANGLEY FIELD, VA., *April 15, 1935.*

#### REFERENCES

1. King, Ernest J.: Progress in Naval Aviation. Mech. Eng., vol. 56, no. 10, October 1934, pp. 613-615.
2. Mucklow, G. F.: The Effect of Reduced Intake-Air Pressure and of Hydrogen on the Performance of a Solid Injection Oil Engine. R. A. S. Jour., vol. 31, no. 193, January 1927, pp. 17-59.
3. Helmore, W., and Stokes, P. H.: Hydrogen-Cum-Oil Gas as an Auxiliary Fuel for Airship Compression Ignition Engines. British Roy. Aircraft Establishment, Report No. E. 3219, October 1930.
4. Spanogle, J. A., and Collins, John H., Jr.: A Balanced Diaphragm Type of Maximum Cylinder Pressure Indicator. T. N. No. 359, N. A. C. A., 1930.
5. Gerrish, Harold C., and Tessman, Arthur M.: Relation of Hydrogen and Methane to Carbon Monoxide in Exhaust Gases from Internal-Combustion Engines. T. R. No. 476, N. A. C. A., 1933.
6. Fenning, R. W., and Cotton, F. T.: Experiments on the Ignition of Gases by Sudden Compression. R. & M. No. 1324, British A. R. C., 1930.
7. Fulton, Garland: Improving Airship Performance. A. S. M. E. Trans., vol. 56, no. 5, May 1934, pp. 301-303.
8. Bone, William A., and Townend, Donald T. A.: Flame and Combustion in Gases. Longmans, Green and Co., Ltd., London, 1927, p. 100.