

## REPORT 949

### EFFECT OF SCREENS IN WIDE-ANGLE DIFFUSERS

By G. B. SCHUBAUER and W. G. SPANGENBERG

#### SUMMARY

*An experimental investigation at low airspeeds was made of the filling effect observed when a screen or similar resistance is placed across a diffuser. The filling effect is found to be real in that screens can prevent separation or restore separated flow in diffusers even of extreme divergence and to depend principally on screen location and pressure-drop coefficient of the screen. Results are given for three different diffusers of circular cross section with a variety of screen arrangements. Effects of single screens and multiple screens are shown. The mechanics of the filling effect is explained, and possible efficiencies are discussed. Results of arrangements of multiple screens in wide-angle diffusers are given to show a possible application to damping screens as used in wind tunnels to reduce turbulence.*

#### INTRODUCTION

An investigation of diffuser-screen combinations was undertaken at the National Bureau of Standards under the sponsorship and with the financial assistance of the National Advisory Committee for Aeronautics in an effort to clarify the so-called "filling effect" commonly observed when a screen or similar resistance is placed at the mouth of a wide-angle subsonic diffuser.

A wide-angle diffuser is defined herein as one in which the cross-sectional area increases so rapidly in the direction of flow that separation is to be expected. Under ordinary conditions this would include all conical diffusers with walls diverging with a total included angle greater than about 8°.

About the time that damping screens for reducing turbulence were found to be of use in the larger wind tunnels, the NACA adopted a rapidly expanding section just ahead of a screen to reduce the loss through the screen. It appears to have been this use of a wide-angle diffuser followed by a screen that first aroused general curiosity and some skepticism about the possibility of filling diffusers by this means. Intuitively it could be seen that a screen would have a tendency to spread the flow by its damming effect, but the details of the effect were not clear. As far as is known, the first quantitative study of the effect was made by McLellan and Nichols (reference 1), who were concerned with the practical advantages of wide-angle diffusers just ahead of heat exchangers. They showed that the filling effect was real and that high diffuser efficiencies could be obtained, but they did not study the flow phenomena in sufficient detail to explain the effect. Later Squire and Hogg (reference 2) investigated several diffuser-screen combinations for reducing turbulence in wind tunnels, including cases when screens were distributed through a diffuser. They demonstrated interest-

ing and useful effects but did not explain the reason for the observed effects.

It was the purpose of the present work to investigate the phenomena of flow through diffusers containing screens in sufficient detail to clarify the mechanics of the process and to show how best advantage can be taken of the filling effect of screens or similar resistances. From the practical standpoint, interest is limited mainly to screens of low solidity where the pressure drop is of the order of the dynamic pressure. When the pressure drop is many times the dynamic pressure, the flow through all pores of the screen is determined by the pressure drop and is nearly equal regardless of the condition of the approach flow. The investigation has therefore been restricted to screens of low solidity. Fine screens have been used to permit measurements close to a screen, and diffusers of circular cross section have been used to avoid corners. The experiments were conducted with air at relatively low speeds at which compressibility can be neglected. It is hoped that the information obtained is adequate to indicate where diffuser-screen combinations can be used to advantage. The application treated in detail involves such combinations used with damping screens for the reduction of wind-tunnel turbulence.

The authors wish to acknowledge the assistance of Messrs. I. A. Kenerson and M. J. Noble, who made many of the installations and obtained some of the data.

#### SYMBOLS

$x$	distance along axis of duct or diffuser
$r$	radial distance from axis of duct or diffuser
$R$	maximum radius of duct or diffuser
$D$	diameter of duct or diffuser
$A$	cross-sectional area of duct or diffuser
$u$	axial component of velocity
$v$	radial component of velocity
$q$	dynamic pressure
$q_r$	reference pressure; herein taken as pressure drop across inlet nozzle of duct system (see fig. 1)
$p_r$	reference static pressure (see fig. 1)
$p$	static pressure
$\Delta p$	change in static pressure across a screen or between two points
$P$	total flow of potential (pressure) energy per second across any section of duct or diffuser
$K$	total flow of kinetic energy per second across any section of duct or diffuser
$E$	efficiency of diffuser or diffuser-screen combination
$E'$	efficiency of diffuser without taking into account energy losses through screens

- $k$  pressure-drop coefficient of screen
- $S$  solidity of screen, defined as ratio of closed area to total area
- $RN$  Reynolds number
- $\alpha$  angle between flow direction and axis of duct or diffuser
- $f$  turbulence reduction factor

**Subscripts:**

Subscripts 0, 1, 2, . . .  $n$  refer to positions along the axis of duct or diffuser. They also designate a quantity in a cross section normal to the axis passing through the specified position. Position 0 refers to diffuser entrance and  $t$  refers to test section of wind tunnel.

**Examples of subscripts:**

Pressure  $p_1$  is static pressure at section 1;  $E_{1,2}$  is diffuser efficiency between sections 1 and 2. Symbols are sometimes used without subscripts when the meaning is clear—on curves, for example. Symbol  $E$  or  $E'$  without subscripts means diffuser efficiency between section 0 and some section at  $x$ .

**DEFINITION OF TERMS**

**EFFICIENCY**

In a diffuser the cross section of a stream increases and the velocity decreases in the direction of flow. In an efficient diffuser the loss in kinetic energy appears largely as potential energy in the form of a pressure rise. The customary definition of the efficiency of a diffuser, and the one used herein, is

$$E = \frac{\text{Gain in potential energy}}{\text{Loss in kinetic energy}}$$

There are various ways to express gain in potential energy and loss in kinetic energy. For example, since  $p$  and  $q$  are the potential and kinetic energy per unit volume, respectively, the efficiency between two points may be expressed as

$$E_{1,2} = \frac{p_2 - p_1}{q_1 - q_2} \quad (1)$$

where point 2 is downstream from point 1. If  $p$  and  $q$  are constant over cross sections 1 and 2, the diffuser efficiency between these two sections is given by equation (1). If section 1 is at the beginning and section 2 is at the end of a diffuser, equation (1) expresses the efficiency of the diffuser. Because of the effect of the shape of the walls, the presence of a boundary layer, and possibly separation of the flow,  $p$  and  $q$  are never entirely constant over any cross section. Consequently the efficiency between two sections of a diffuser can be expressed exactly only in terms of the flow of potential and kinetic energy through the two sections. Thus the exact expression for the efficiency is

$$E_{1,2} = \frac{P_2 - P_1}{K_1 - K_2} \quad (2)$$

where

$$P_2 = \int_0^{A_2} p_2 u_2 dA \quad P_1 = \int_0^{A_1} p_1 u_1 dA$$

$$K_1 = \int_0^{A_1} q_1 u_1 dA \quad K_2 = \int_0^{A_2} q_2 u_2 dA$$

In theoretical derivations, equation (1) is often used in preference to equation (2) because of the simplicity attending the use of  $p$  and  $q$ . In some cases equation (1) is a sufficiently close approximation for practical purposes, especially in narrow-angle diffusers and in cases when the efficiency is high—say, 80 percent or greater.

In the present investigation equation (2) was always used to calculate efficiencies from experimentally determined quantities. Values of  $P$  and  $K$  were determined by graphical or numerical evaluation of the foregoing integrals. It was found necessary to sacrifice accuracy for convenience by using the velocity corresponding to  $q$  in place of the axial velocity  $u$  because of the difficulty of measuring  $u$  separately. Obviously this procedure involves an error when  $v$  is not zero, but the error is of the same order as the experimental error in the measurement of  $q$ .

It is convenient to make use of an efficiency  $E'$  which does not include losses due to the screens themselves. If  $E'$  is used when screens are present, it denotes the flow efficiency of the diffuser as affected by screens. It is referred to as "flow efficiency."

**FILLING**

Filling is a term used rather loosely to denote that, either because of diffuser design or of the effect of a screen, the flow takes place throughout all available volume in the diffuser. In this sense it means absence of separation. Although the presence or absence of separation is an important flow criterion, still another is the velocity distribution. In order to include both of these, a filled condition might be defined as one in which the velocity distribution at every section is similar to that at the diffuser entrance. This definition has the objection that it ignores the effect of the geometry of the diffuser on the flow pattern. The present results are given in such form that performance may be judged either by the separation criterion or by the similarity criterion.

Use is made of charts called streamline diagrams, which consist of lines indicating the radial distances within which 0.1, 0.2, 0.3, and so forth of the total observed flow occur. In computing the total observed flow when separation was present, the reverse flow near the wall was neglected. In these cases the observed volume was generally a few percent too high, and the lines are not accurately streamlines.

**PRESSURE-DROP COEFFICIENT  $k$**

By definition the pressure-drop coefficient of a screen is

$$k = \frac{\Delta p}{q}$$

where  $q$  is the dynamic pressure of a uniform parallel flow approaching normal to the plane of the screen and  $\Delta p$  is the static-pressure drop across the screen. The value of  $k$  is determined experimentally by measuring  $q$  and  $\Delta p$ . The coefficient depends on the solidity  $S$  and on a Reynolds number equal to the diameter of the wire times the velocity corresponding to  $q$ , divided by the kinematic viscosity.

The coefficient  $k$  is useful for calculating  $\Delta p$  when the flow is normal to the screen. The pressure drop may be abnormally high if the stream approaches the screen at a considerably large angle to the normal. In any case  $k$  is used as a parameter for connecting a given screen with its aerodynamic effect, such as its effect on turbulence and on the space distribution of velocity.

### APPARATUS AND METHODS

#### GENERAL ARRANGEMENT

The apparatus for investigating diffuser-screen combinations is shown in figure 1. It consists essentially of a diffuser

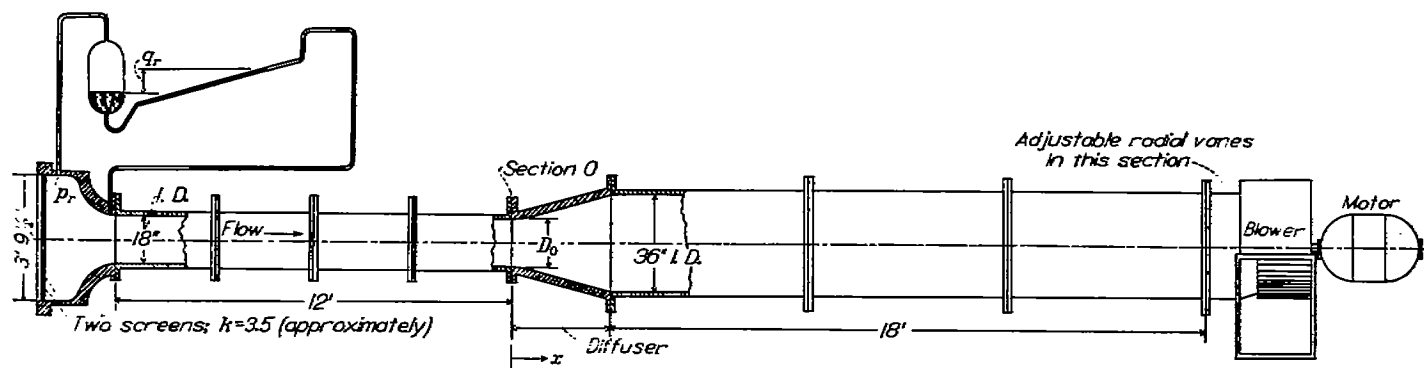

FIGURE 1.—Diffuser and duct-system assembly used to study effects of fine screens in diffusers.

with a cylindrical entrance duct 18 inches in diameter and a cylindrical exit duct 36 inches in diameter. A centrifugal fan, with its intake at the end of the large duct, drew air through the system. Airspeed was controlled by adjustable inlet vanes on the fan. The top speed was somewhat in excess of 100 feet per second in the entrance duct, this speed depending on the amount of resistance present. Since the exhaust was far from the entrance and the room was large, disturbances at the entrance were usually small. Screening on the entrance nozzle was found to improve the steadiness of the flow.

The entrance duct consisted of four 3-foot sections, so that its length could be varied to change the thickness of the boundary layer at the diffuser entrance. With the full 12-foot length, the boundary layer was about 3 inches thick and the velocity was uniform over a central core 12 inches in diameter. When fully developed turbulent pipe flow was desired at the diffuser entrance, the boundary layer was artificially thickened by screens with cutout centers placed in the duct 9 feet ahead of the diffuser. The boundary layer was turbulent in all cases.

### DIFFUSERS

Most of the measurements were made with diffusers A and B shown in figure 2. These were essentially wide-angle conical diffusers with rounded entrances and an area ratio of 1 to 4. They were built as separate units for insertion between the 18-inch and the 36-inch ducts. Diffuser C, shown in figure 2, was shaped to conform approximately to the outer streamlines of a jet passing through a screen. It was not used extensively. The manner of installing screens is also illustrated in figure 2. Flush mounting eliminated obstructions and prevented breaks in the contour of the diffuser. Tension in the screens was just sufficient to remove slack.

### INSTRUMENTS

It was planned to measure mean velocity and pressure throughout the entire field of flow, particularly as near the walls and screens as was practicable. With this in mind, the dimensions of ducts and diffusers were made as large as

possible and still permit the use of screen widths commercially available.

In practice it proved difficult to make static- and dynamic-pressure traverses near the upstream side of a screen with instruments of conventional design. After experimenting with several arrangements of pitot-static tubes, the two shown in figure 3 were adopted. Instrument A was of nearly conventional design and could be used where there was sufficient room—for example, where no screens were present, or downstream from a screen. Instrument B was that used for making measurements upstream from screens and between them. With this instrument continuous traverses could be made within 1 inch of the upstream side of a screen. Both instruments read true static and dynamic pressure to within 1 percent at zero angle of incidence. Characteristics at other angles are given in figure 4.

Velocity and pressure distributions were determined by traversing along any chosen diameter with one or the other of these instruments. The support member extended completely across the stream to provide strength and side-to-side symmetry. The tubes were always aligned with the axis

of the duct system; this meant that the flow, particularly near a screen, often approached them at a considerably large angle. Possible errors from this source, as calculated from figure 4, were not significant in the over-all result, and hence no corrections were applied.

The directions of streamlines derived from velocity meas-

urements were checked by means of a thin metal strip about  $\frac{3}{4}$  inch wide, coated with volatile oil and lampblack and placed along a diameter edgewise to the flow. Air was allowed to flow until the oil had evaporated, after which the pattern of streaks on the strip showed the average direction of the flow at each point along the diameter.

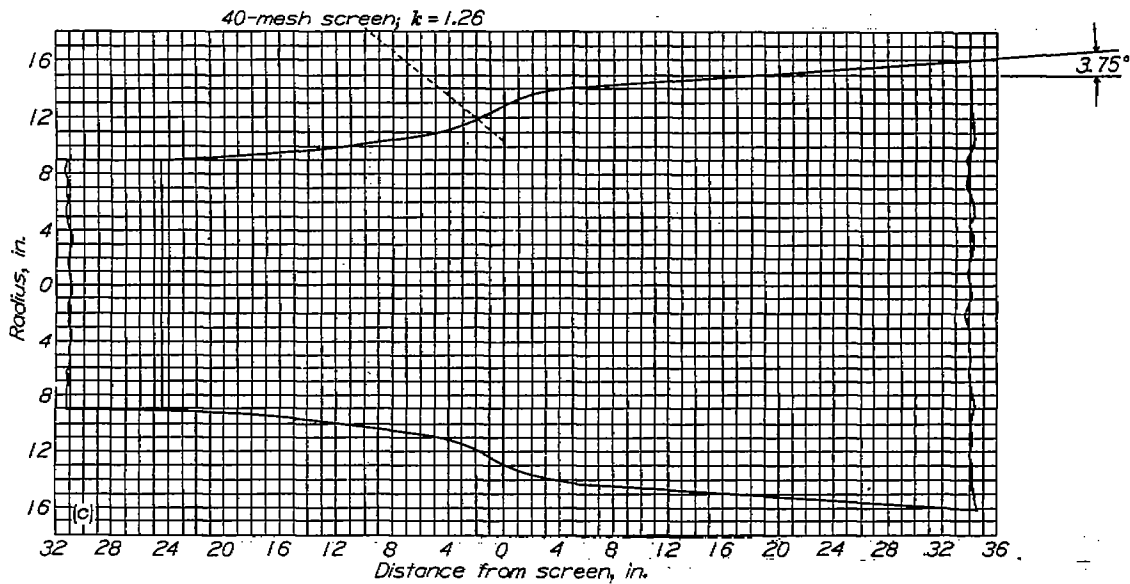
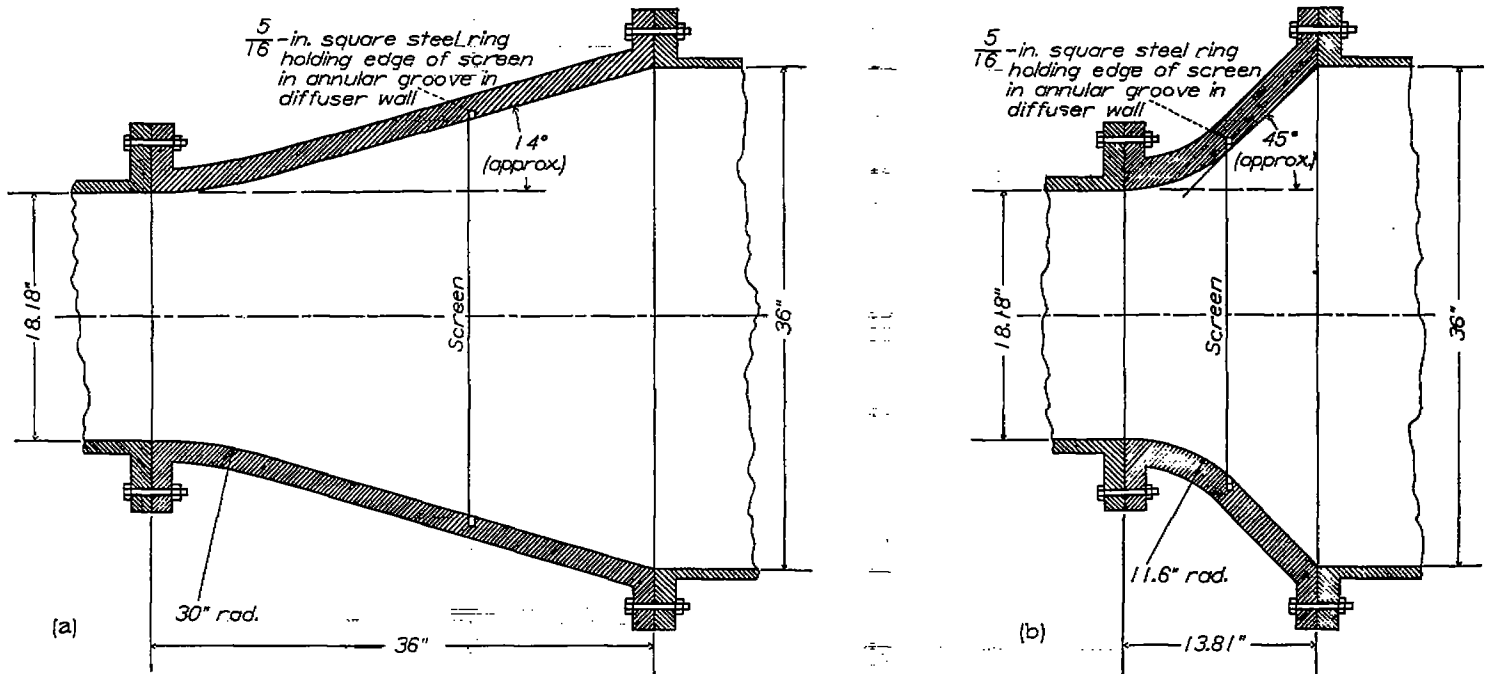

(a) Diffuser A. (b) Diffuser B.  
 (c) Diffuser C.

FIGURE 2.—Outline sketches of diffuser assemblies.



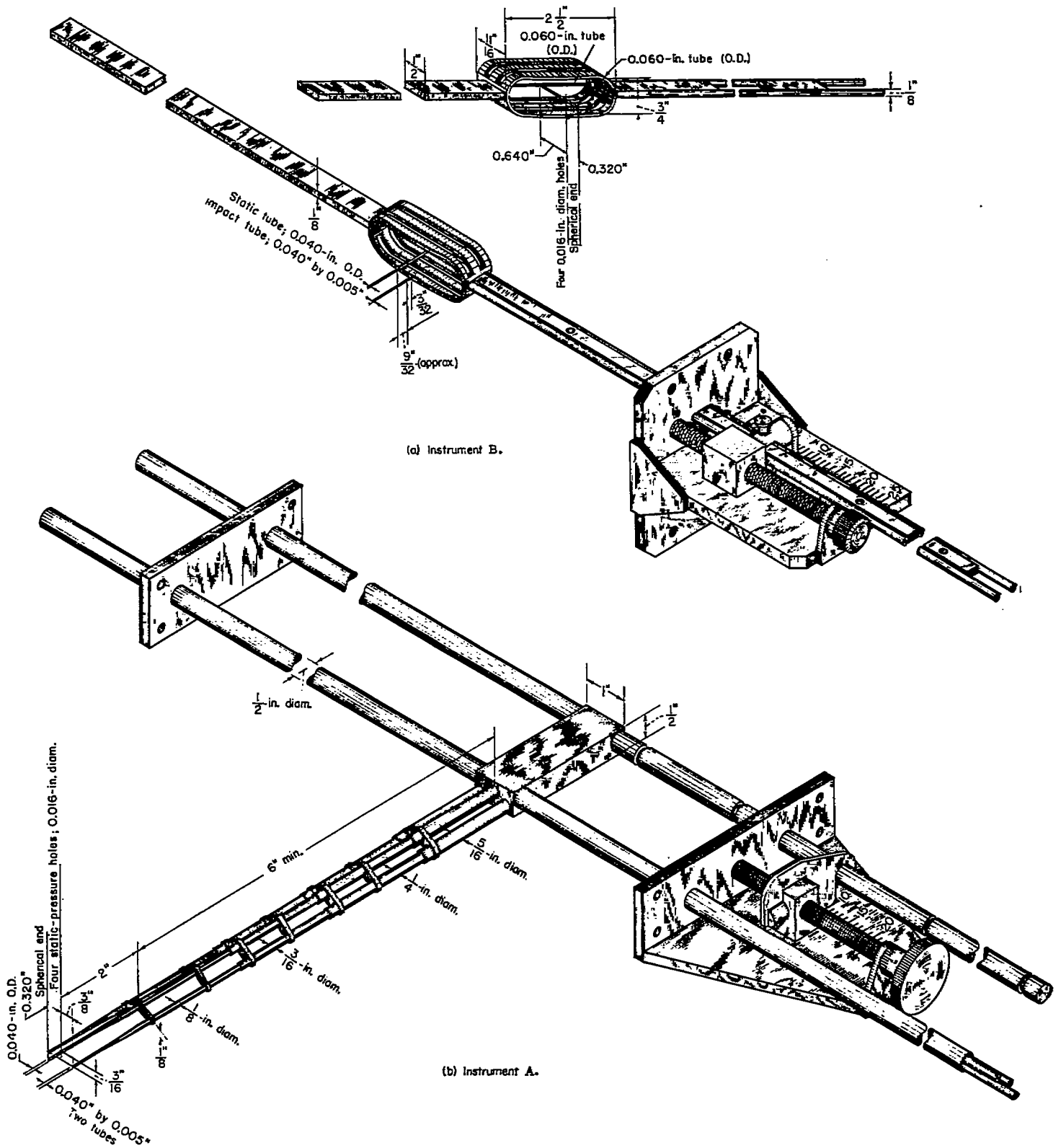

FIGURE 3.—Pitot-static-tube assemblies. Instrument A used in back of screens; instrument B used ahead of and between screens.

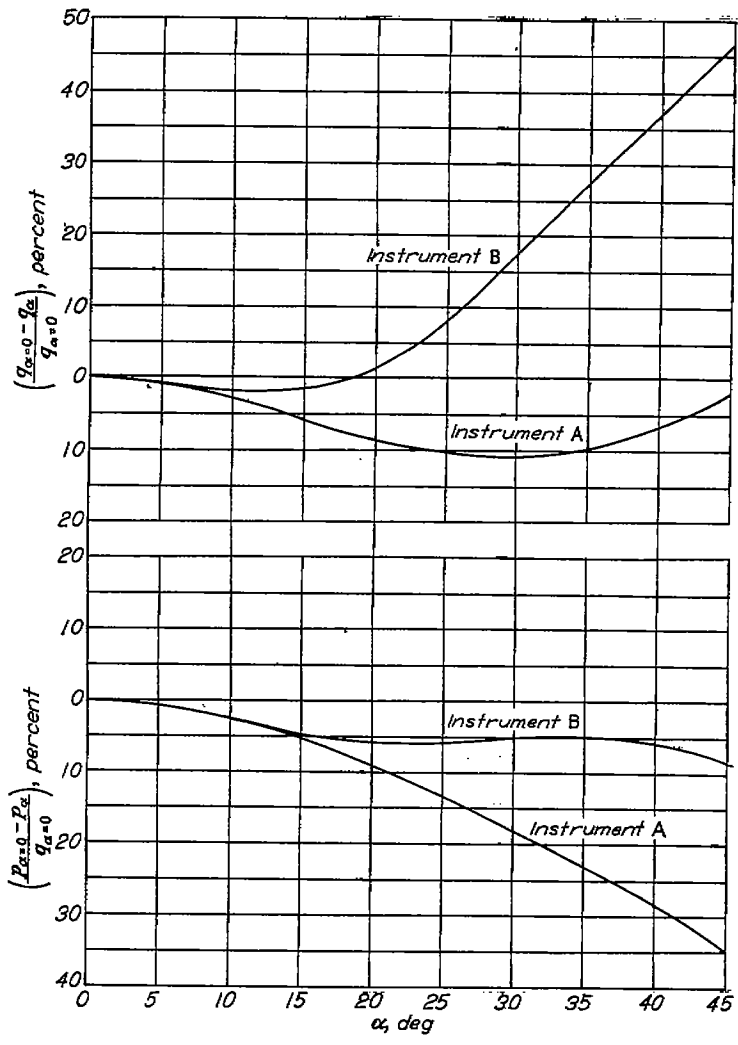

FIGURE 4.—Pitot-static-tube characteristics.

**SCREENS**

The principal characteristics of the screens used in this investigation were a large number of meshes per inch, small wire size, and low solidity. The first two, normally described as the fineness, are essential if irregularities in dynamic pressures close to the downstream side of a screen are to be avoided. Present work was limited to screens of low solidity.

Since the value of  $k$  depends on the screen Reynolds number as well as on the solidity, values of  $k$  were determined for each screen at various wind speeds. This was done on samples placed in the 18-inch duct, and measurements were made at the center where  $q$  was uniform and the flow was normal to the screen. Measured values of  $k$  are given in figure 5 as a function of  $S$  at several Reynolds numbers. The theoretical curve of Eckert and Pflüger (reference 3) is also shown. The discrepancy between theory and experiment is the same here as in reference 3 for screens of low solidity. Basic data

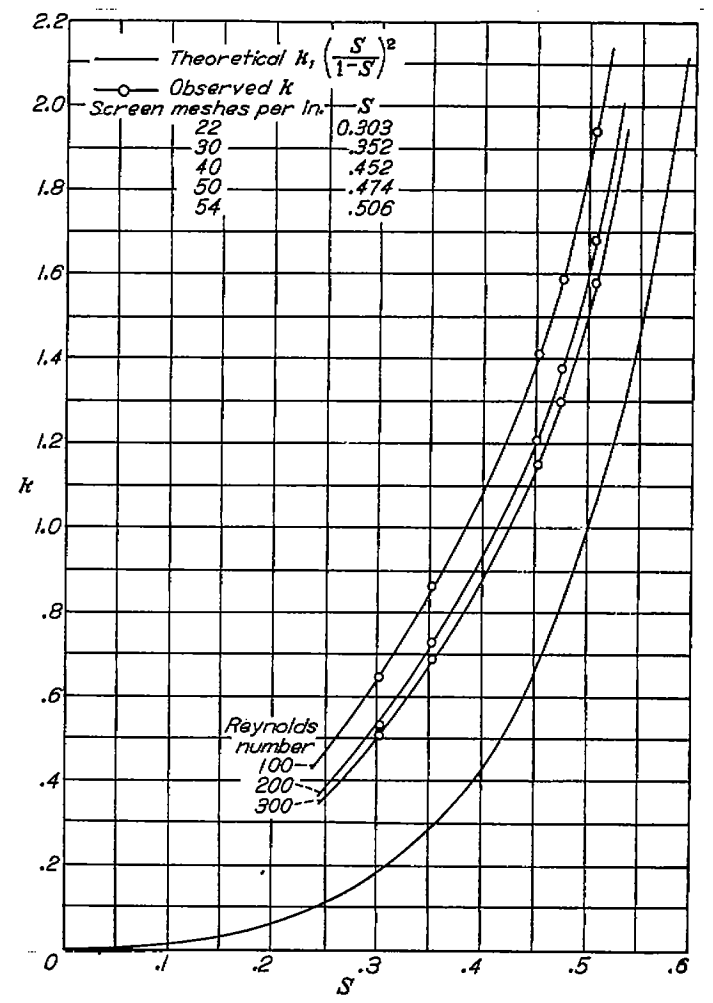

FIGURE 5.—Variation of pressure-drop coefficient with solidity for screens at various Reynolds numbers. Curve without points is theoretical curve according to Eckert and Pflüger (reference 3).

TABLE 1

**SCREENS USED IN DIFFUSERS**

Meshes per inch	Wire diameter (in.)	Solidity, $S$	$k$ at $RN=200$
22	0.0075	0.303	0.54
30	.0065	.352	.74
40	.0065	.452	1.21
50	.0055	.474	1.38
54	.0055	.506	1.69
* 75	-----	-----	2.90 nominal

\* The 75-mesh screen is a silk bolting cloth. It was not possible to measure the thread diameter with sufficient accuracy to determine solidity. All other screens are wire cloth.

on the screens used in the present work are summarized in table 1.

It is pointed out that a precise value of  $k$  for a screen in a diffuser is not particularly significant because speed and direction of flow vary from point to point over the area of the screen. Values given in connection with various arrangements are those corresponding to the average velocity based upon the total flow and the total exposed area of the screen.

EXPERIMENTS WITH SINGLE SCREENS

PROCEDURE

Systematic measurements were made with single screens at various positions in diffuser A. For each screen and each position, static- and dynamic-pressure traverses were made across two diameters 90° apart at several stations. Representative distributions across a section were obtained by averaging values on the two diameters. Enough locations were selected in each case to define the flow characteristics through the entire diffuser. When preliminary tests showed that there was no significant effect of Reynolds number, except on the value of  $k$ , all measurements were made at a single wind speed of about 100 feet per second in the entrance duct.

For the work on single screens the entrance duct was 8 diameters (12 ft) long. This produced a turbulent boundary layer about 3 inches thick. According to reference 1, diffuser efficiency decreases with increasing length of the entrance duct up to 6 diameters but changes little thereafter. An entrance length equal to 8 diameters was therefore chosen as representative of the most severe conditions under which a diffuser would be used in practice.

RESULTS WITH DIFFUSER A

Many measurements were made with diffuser A because these were not complicated greatly by the inclination of the flow to the axis. In other words, reliable results could be obtained with pitot-static tubes parallel to the axis. From a large number of results involving some repetition, there have been selected for presentation representative samples which convey all the pertinent information. These have been condensed in the form of streamline diagrams which bring out the salient features.

Figure 6 pertains to diffuser A without screens. The changes in kinetic and potential energy and the resulting efficiency are shown by the top row of diagrams. A value of efficiency from a curve such as this always means the efficiency of that part of the diffuser up to the section located at the chosen value of  $x/D_0$ . In the middle row the left-hand diagram shows the distribution of dynamic pressure across four sections, while the right-hand diagram shows the streamlines and the region of flow separation, the shaded region denoting the wake region between the 1.0-streamline and the wall. This latter diagram is given mainly to show where separation occurred. It is quite inaccurate because the flow was not symmetrical and because there was a large apparent increase in volume flow due to recirculated air downstream from the section at which separation began. The two diagrams in the bottom row show the pressure distribution across several sections and along the streamlines.

It was difficult to make any measurements in the absence

of screens because of the whipping of the stream from side to side. In fact the stream was so unstable and the speeds were so variable in the downstream half of the diffuser that little meaning is attributed to the readings. The approximate distribution of  $q/q_0$  is given across the downstream end, but energy changes, efficiency, and streamlines are given only part way through the diffuser. One of the more noticeable effects of a screen, which cannot be shown in diagrams of mean values, is the remarkable steadying effect on the flow.

Figures 7, 8, and 9 give the results for screens in various positions. Figures 7 (a), 7 (b), and 7 (c) give an over-all picture of the energy changes, efficiencies, and streamlines for five different screens in three selected positions.

Figures 8 (a), 8 (b), and 8 (c) show, on the left-hand side, the distribution of dynamic pressure at the entrance and at various locations within the diffuser. On the right-hand side is shown another type of streamline diagram better suited than that of figure 7 to show the degree of filling of the diffuser. In this type of diagram the streamlines are equally spaced horizontal lines if the flow is perfectly uniform. If the flow is not uniform but maintains a similar pattern throughout the diffuser, all streamlines are still horizontal and straight but not equally spaced. Departures from these conditions are readily apparent and this type of diagram shows at a glance the extent that the diffuser is filled. It must be pointed out that similarity of flow is only a qualitative test for filling, as the shape of the diffuser itself makes the flow pattern dissimilar to that in the entrance duct. However, this effect is not appreciable in the present case. If filling is regarded as simply the absence of separation, the shaded regions in the figures are suitable indexes.

Figures 9 (a), 9 (b), and 9 (c) show the distribution of static pressure normal to the axis of the diffuser at various sections and the distribution of static pressure along streamlines.

Results for screens placed at the extreme downstream end of the diffuser were much like those in figures 7 (c), 8 (c), and 9 (c) and have therefore been omitted. Obviously this diffuser cannot be filled throughout by means of a single screen. When the screen is in the most forward position ( $x/D_0=0.67$ ), increasing  $k$  removes separation and fills the diffuser fairly well upstream but fails to do so downstream. When the screen is in either the middle or rearward positions, increasing  $k$  fills the diffuser downstream but not upstream.

A few tests were made of diffuser A with a 1¼-inch annular space at the periphery of the screen. It was believed that free area at the wall would be an effective means of delaying or preventing separation. However, in the cases tried the free space had very little effect. It was then thought that a free space might be more effective in a diffuser of wider angle.

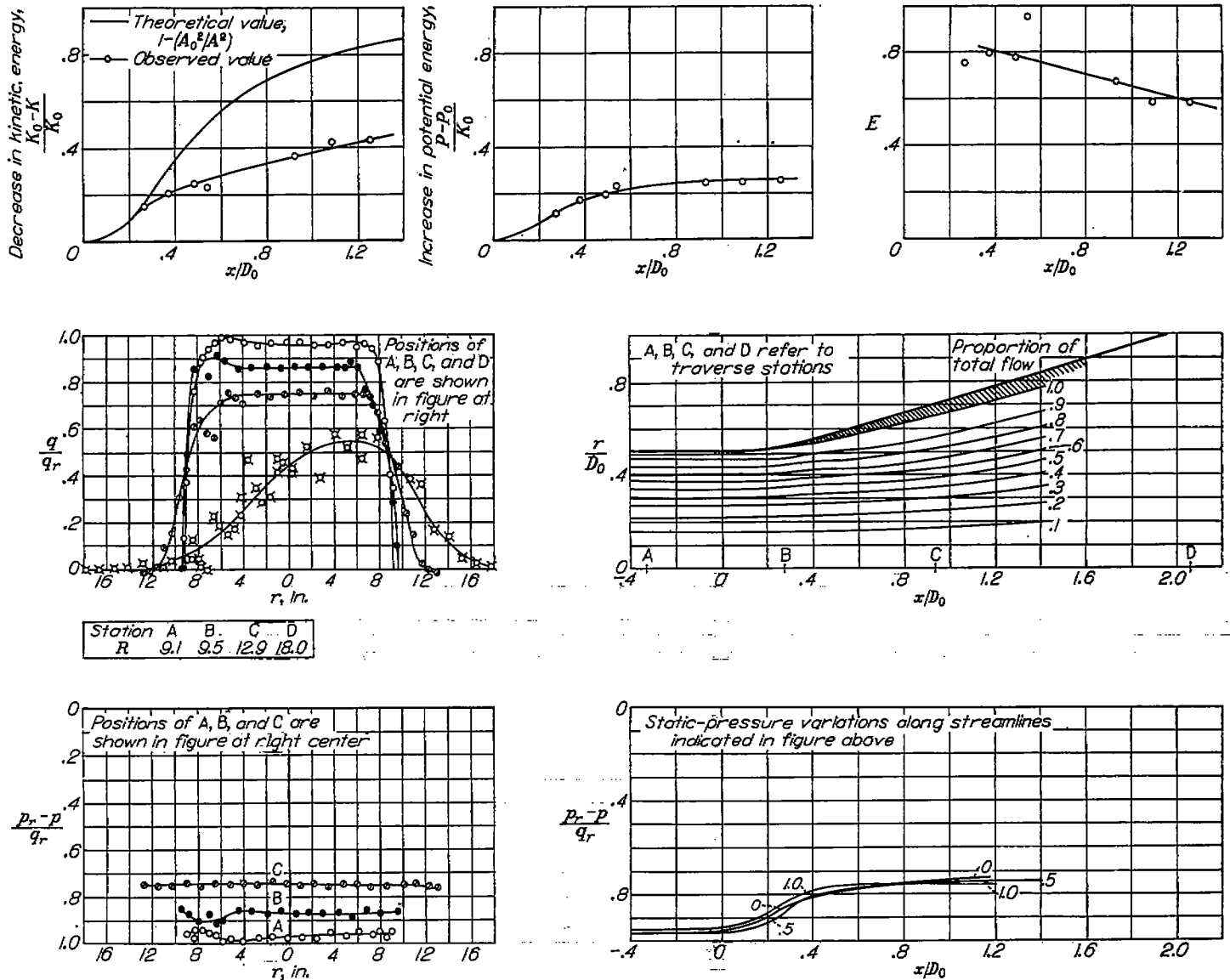
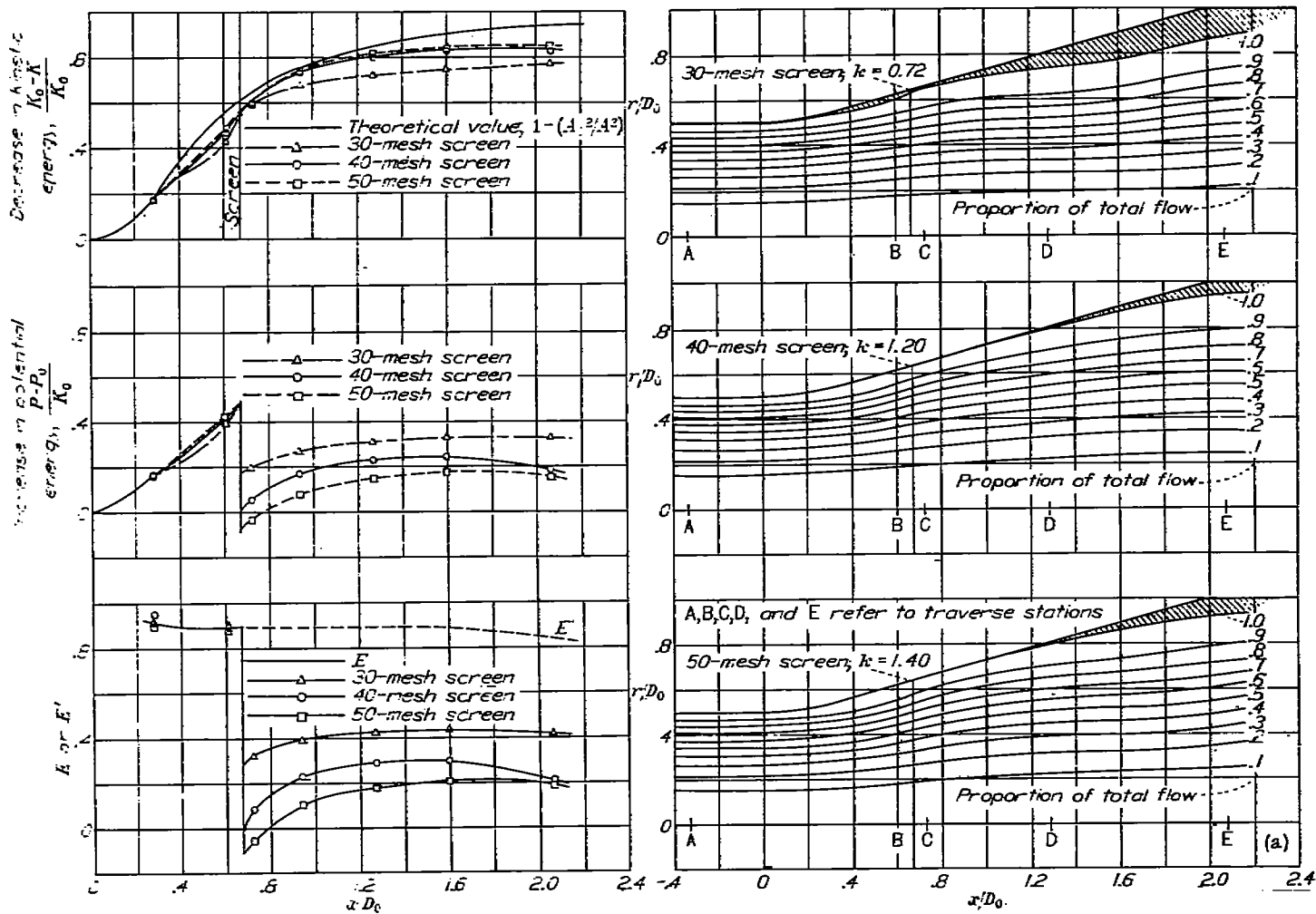

FIGURE 6.—Results of tests of diffuser A without screens. Charts showing changes in kinetic and potential energies, efficiency, dynamic- and static-pressure distributions at various diffuser sections, approximate streamlines, and static-pressure variations along selected streamlines.





(a) Screens placed  $\frac{1}{2}$  duct diameter from diffuser entrance.

FIGURE 7.—Results of tests of diffuser A with various single screens. Charts showing changes in kinetic and potential energies, efficiencies, and approximate streamlines.

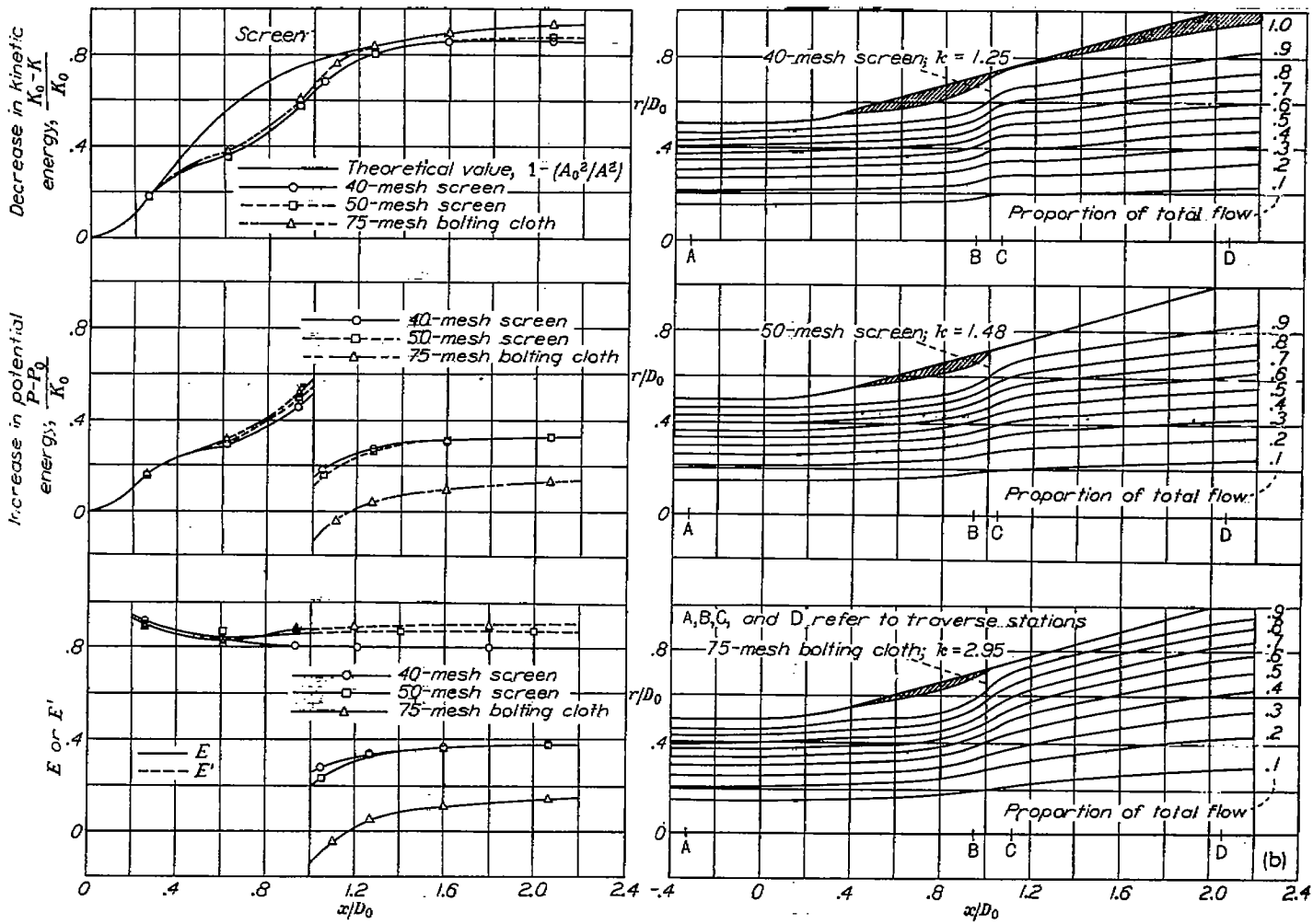

(b) Screens placed 1.0 duct diameter from diffuser entrance.

FIGURE 7.—Continued.

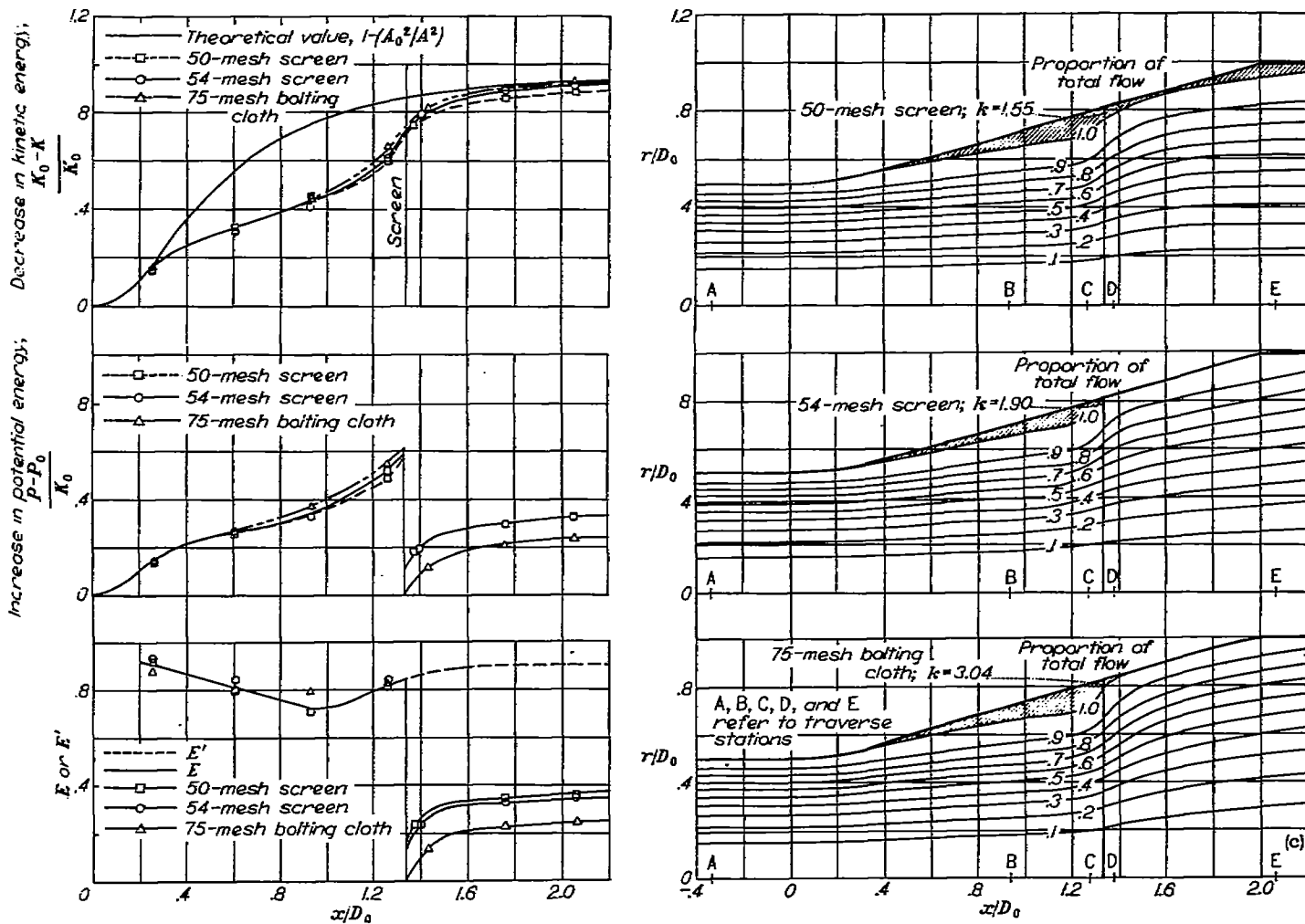

(c) Screens placed  $1\frac{1}{4}$  duct diameters from diffuser entrance

FIGURE 7.—Concluded

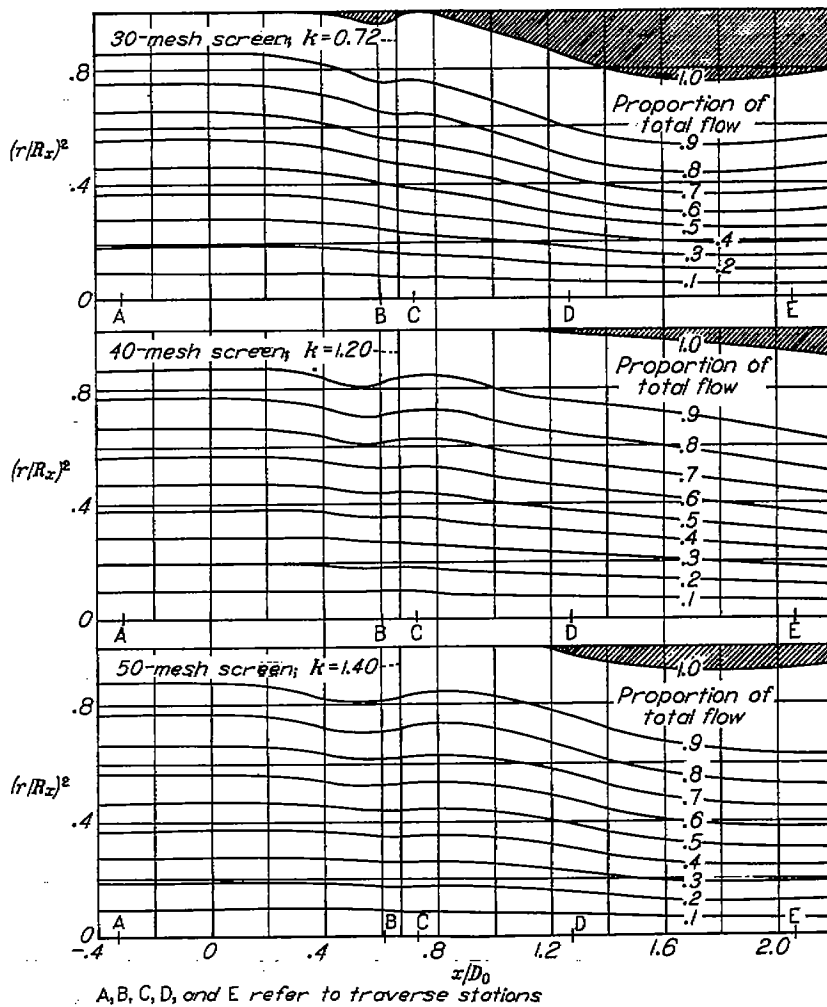
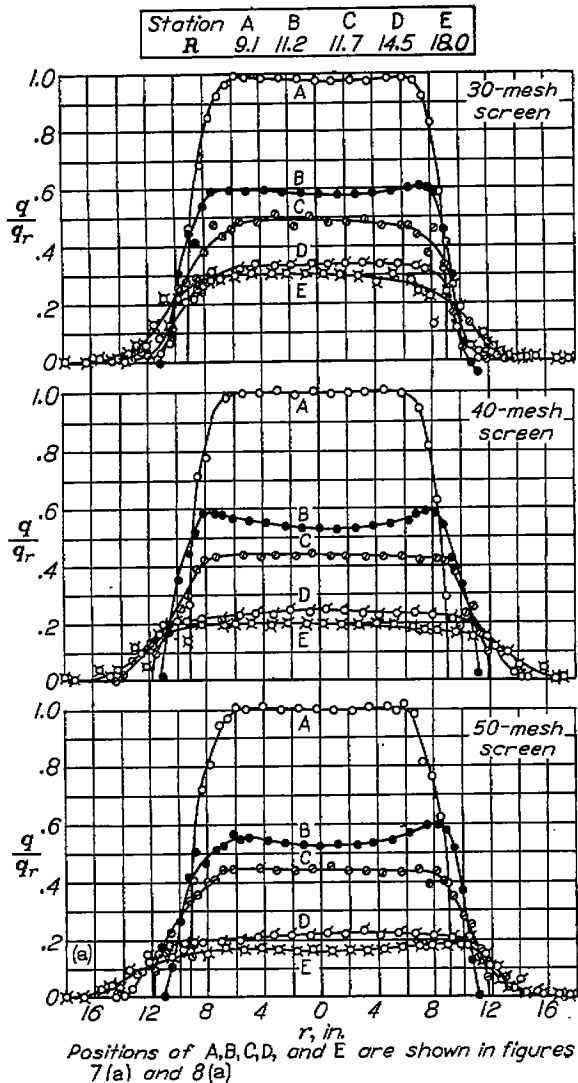

(a) Screens placed  $\frac{1}{4}$  duct diameter from diffuser entrance.

FIGURE 8.—Results of tests of diffuser A with various single screens. Charts showing dynamic-pressure distributions at various diffuser sections and proportions of diffuser area filled by various proportions of total flow.



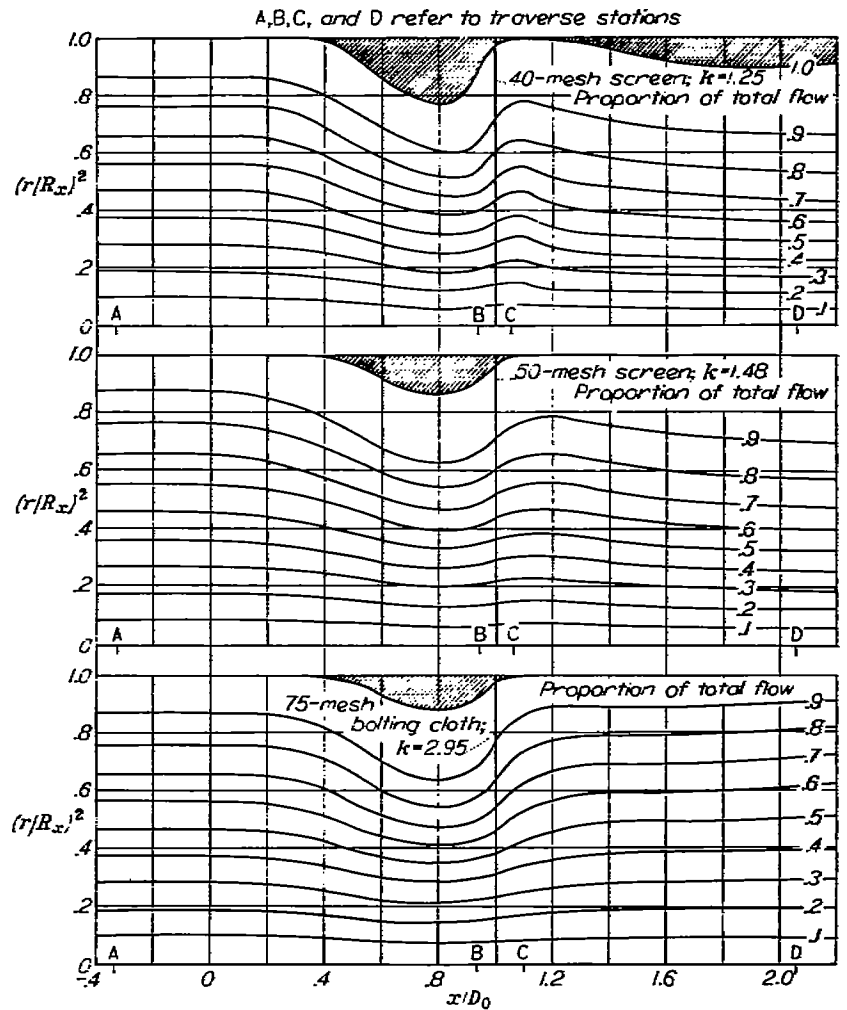
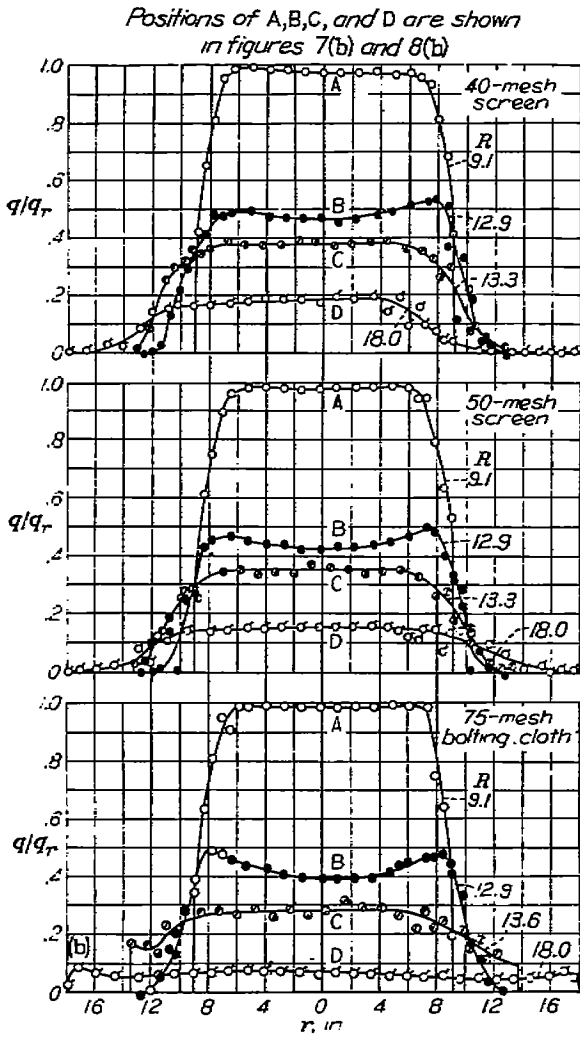

(b) Screens placed 1.0 duct diameter from diffuser entrance.

FIGURE 8.—Continued.

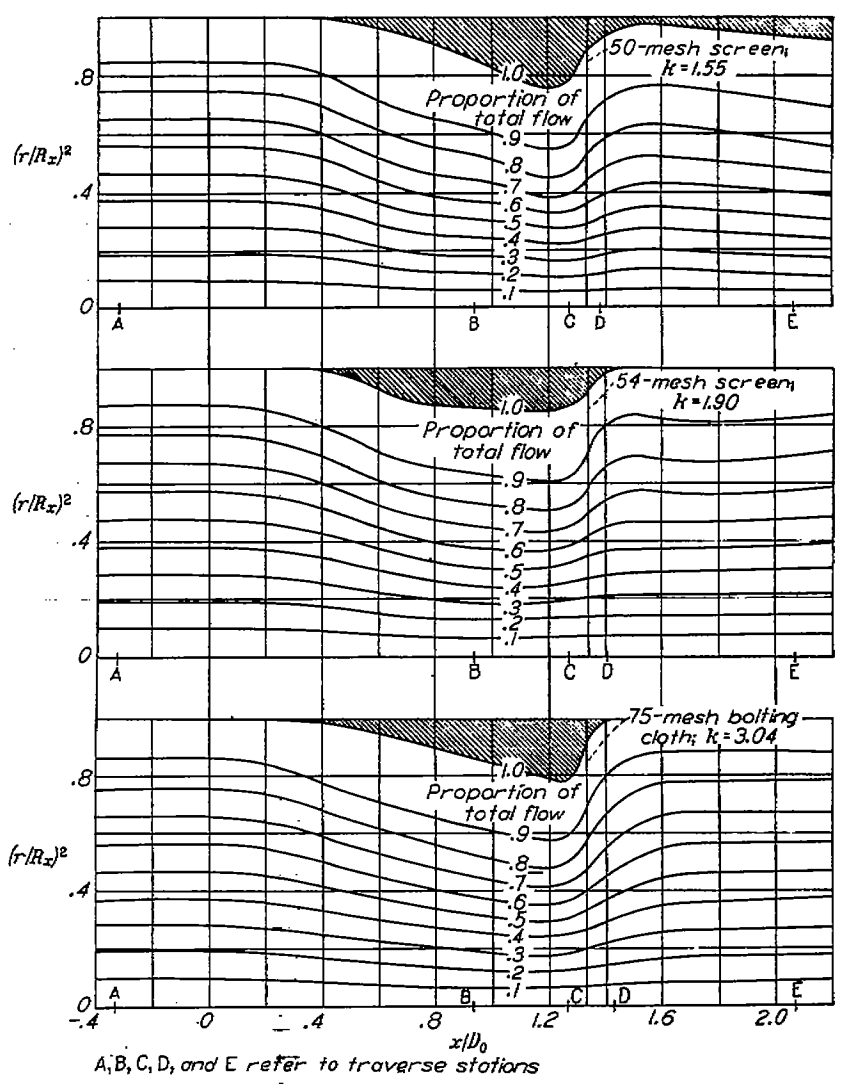
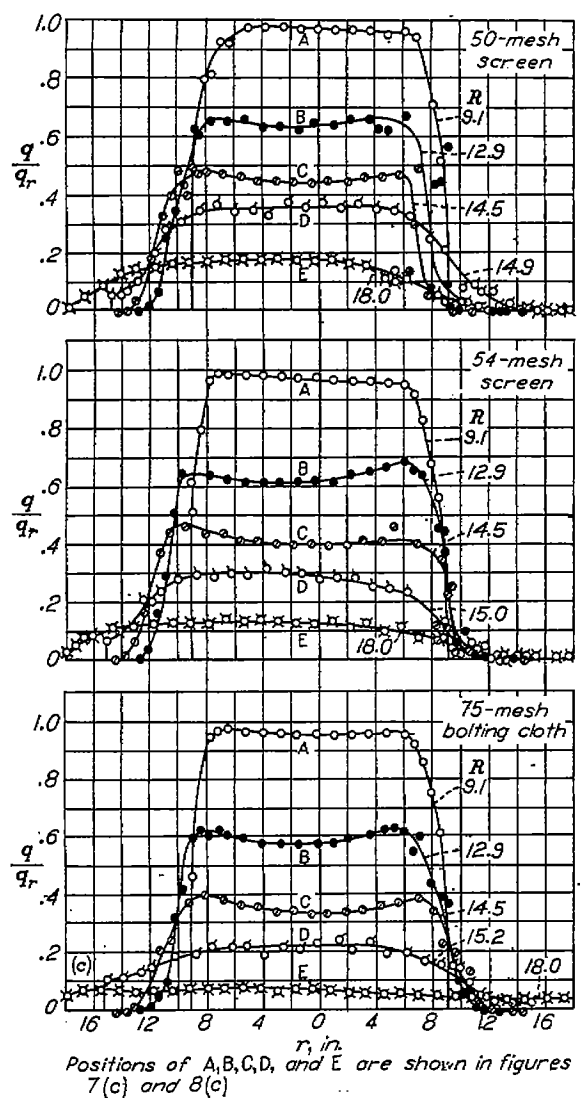

(c) Screens placed  $1\frac{1}{4}$  duct diameters from diffuser entrance.

FIGURE 8.—Concluded.

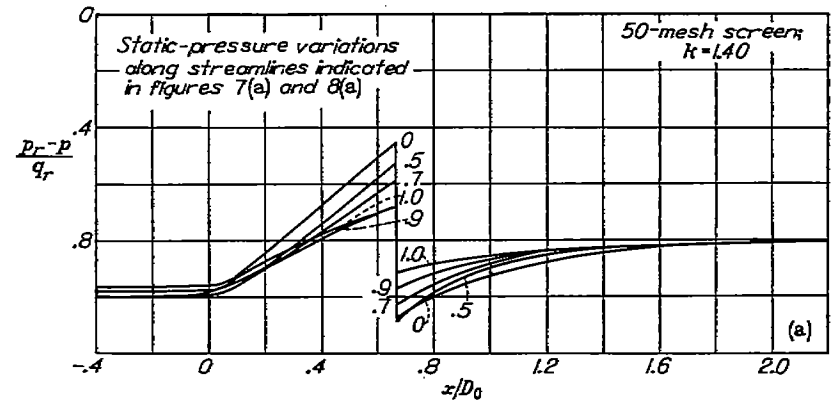
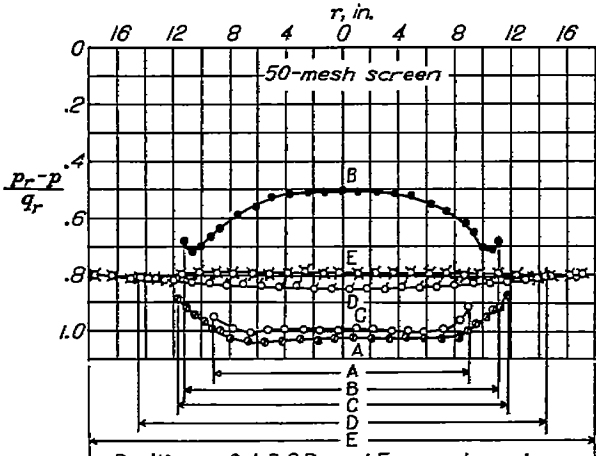
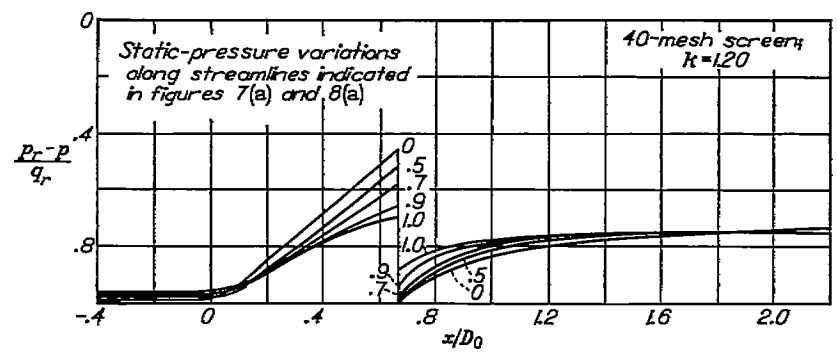
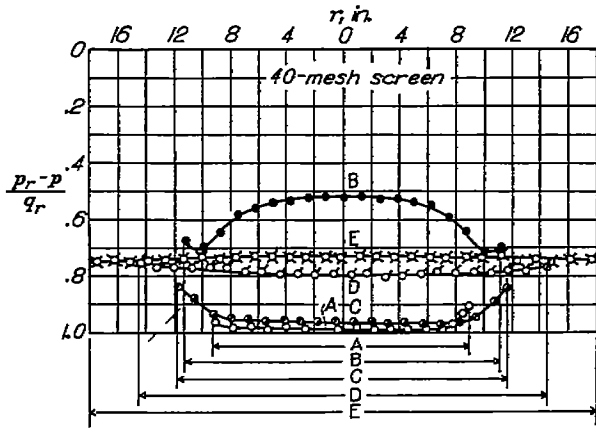
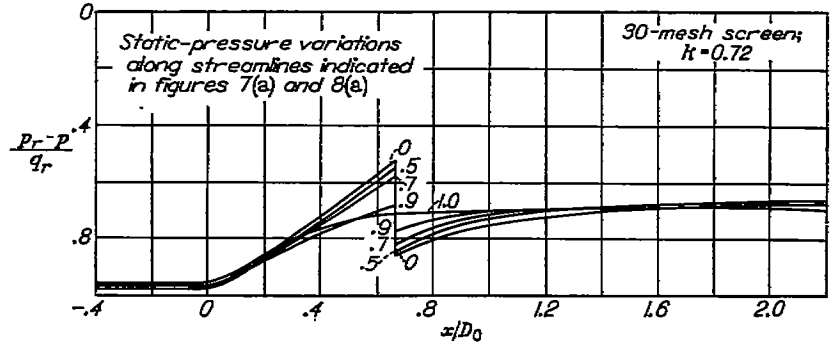
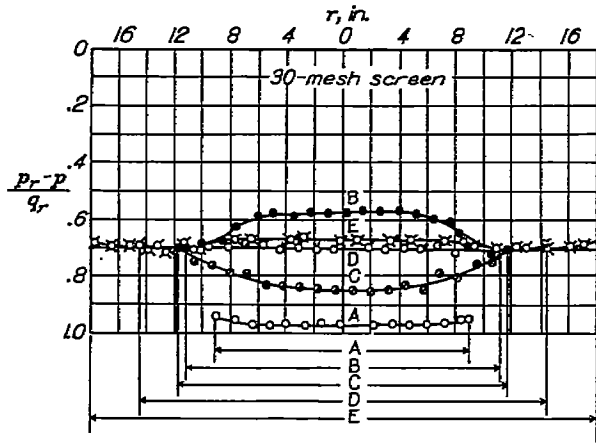

Positions of A, B, C, D, and E are shown in figures 7(a) and 8(a)

(a) Screens placed  $\frac{3}{4}$  duct diameter from diffuser entrance.

FIGURE 9.—Results of tests of diffuser A with various single screens. Charts showing static-pressure distributions at various diffuser sections and along selected streamlines.

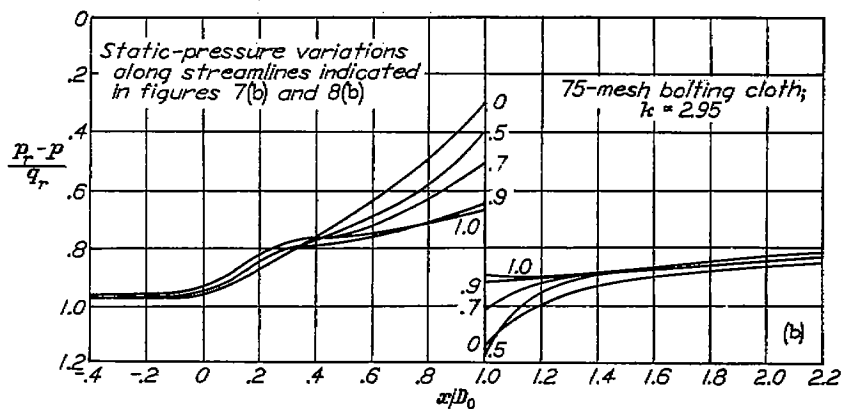
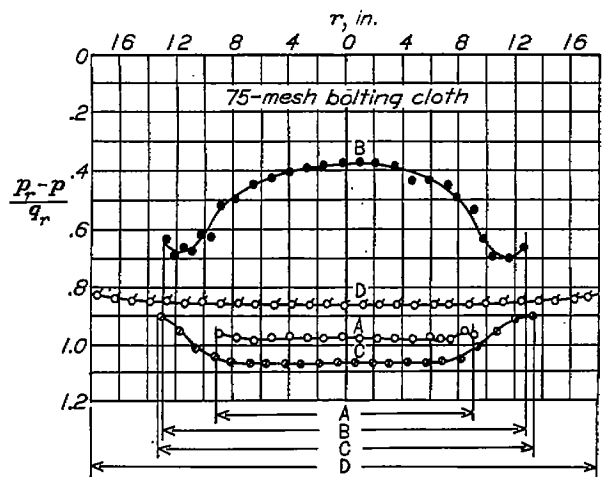
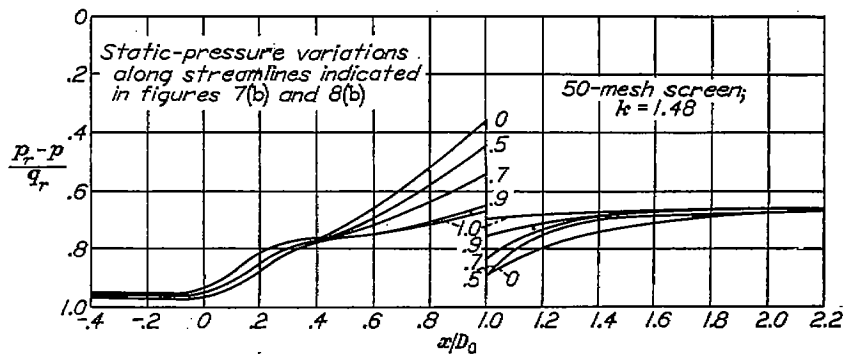
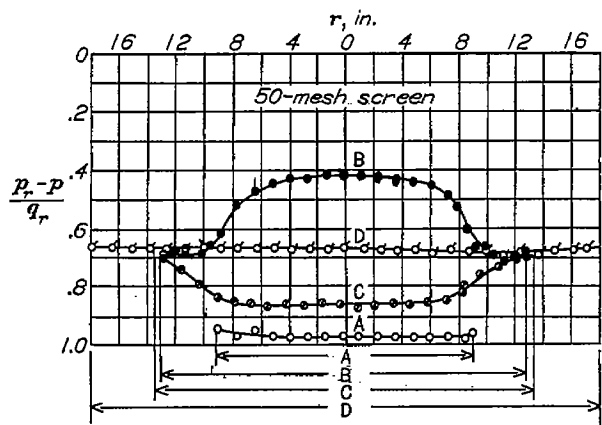
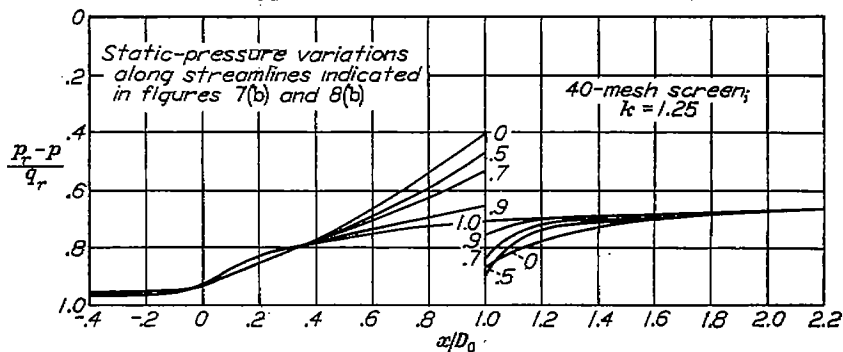
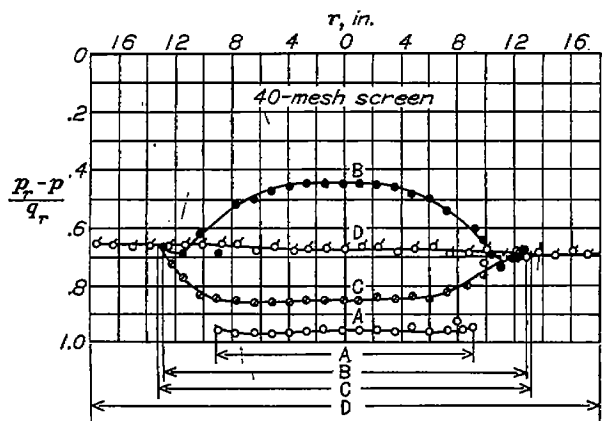

Positions A, B, C, and D are shown in figures 7(b) and 8(b)

(b) Screens placed 1.0 duct diameter from diffuser entrance.

FIGURE 9.—Continued.



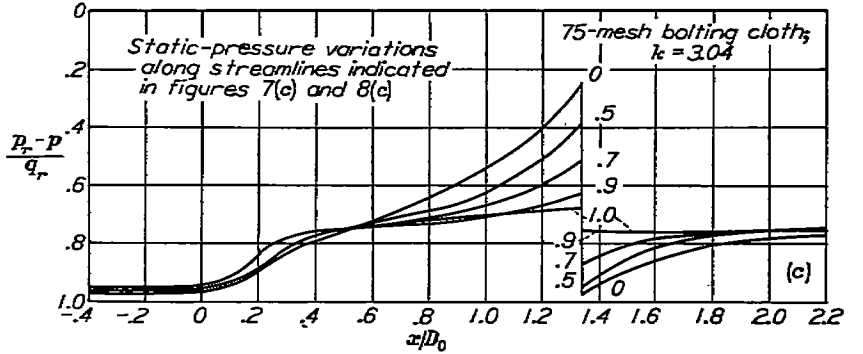
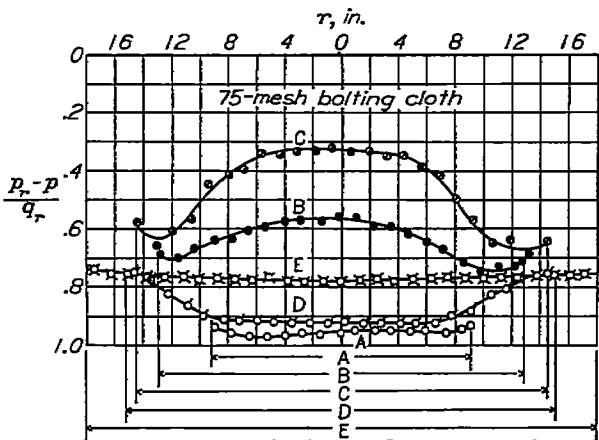
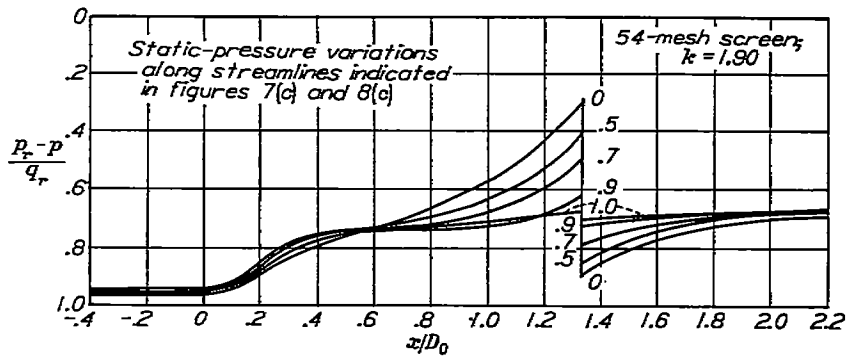
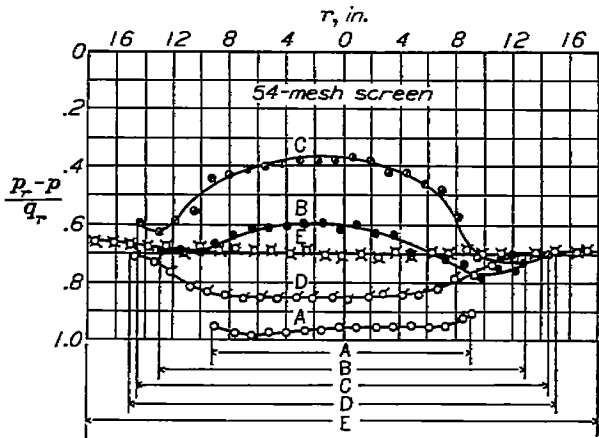
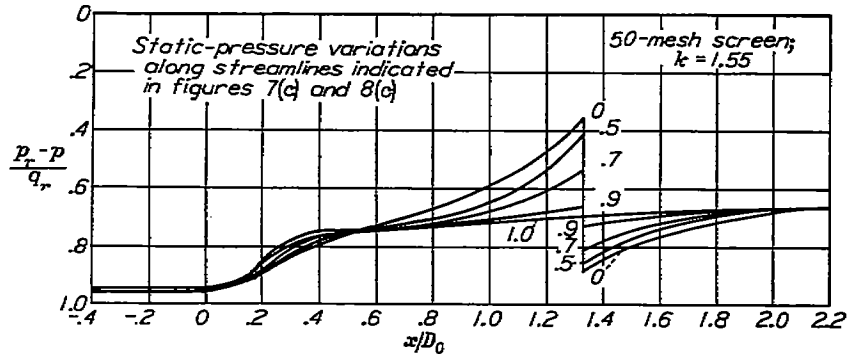
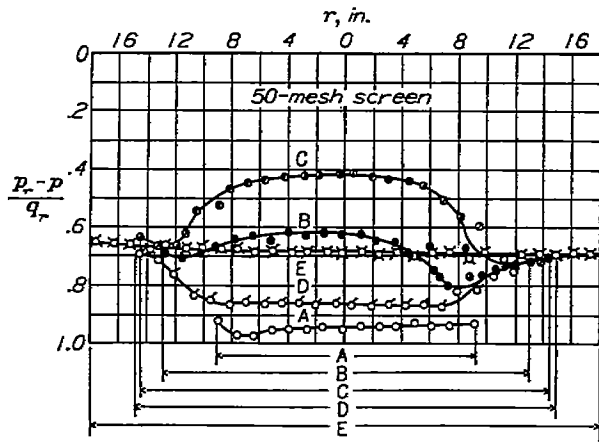

Positions of A, B, C, D, and E are shown in figures 7(c) and 8(c)

(c) Screens placed  $1\frac{1}{4}$  duct diameters from diffuser entrance.

FIGURE 9.—Concluded.

**RESULTS WITH DIFFUSER B**

Figure 10 gives the results of tests of diffuser B without screens. This figure is of the same type as figure 6. Comparison of figures 6 and 10 shows the earlier separation in the diffuser with the wider angle. Separation was so definite and clean-cut in diffuser B that the flow took place as a free jet through the center and was relatively steady.

Tests with single screens in diffuser B were made both with and without a free annular space between the screen and the wall. The results are given in figures 11 and 12, which give the same type of information as figures 7, 8, and 9. It can be noted that the annular space has scarcely any effect on the filling but tends to increase the efficiency  $E$ , particularly if a large drop in static pressure exists near the

wall when the screen spans the entire diffuser. As shown by figures 11 (b) and 11 (c), the spill through the annulus produces peaks in the curves of  $q/q_r$ . However, this spill does not improve the performance of the diffuser appreciably. In fact it may involve an unstable condition resulting in pulsating and nonsymmetrical flow. It was concluded that, inasmuch as the greatest energy losses occur at the screen in the central core of the stream and diminish to zero through the low-velocity region near the walls, an annular space in the low-energy region near the walls had little if any value. In these cases higher efficiency with more uniform flow resulted from substituting a screen having a low value of  $k$  spanning the entire diffuser instead of providing annular space around a screen of higher value of  $k$ .

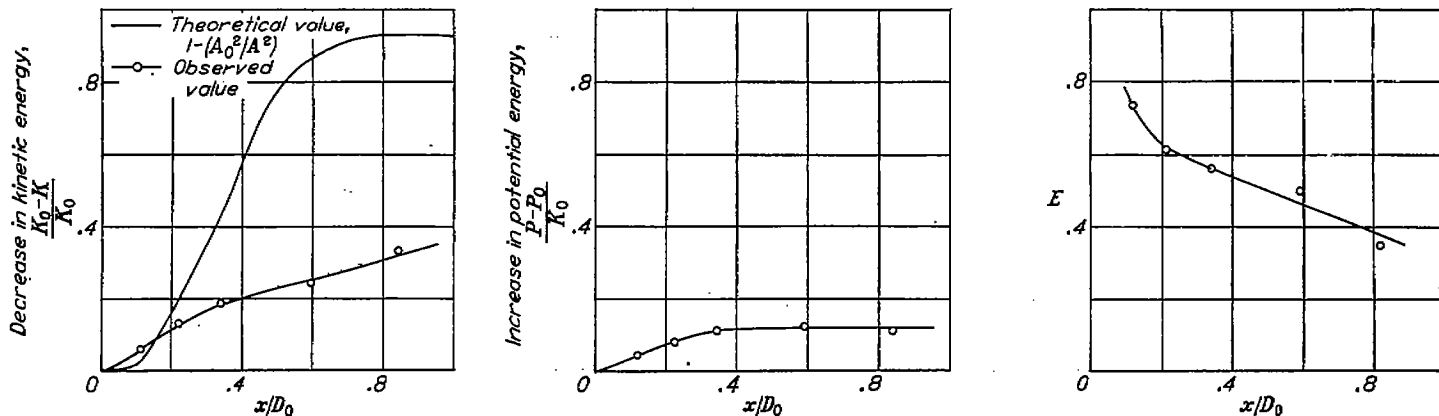

Station	A	B	C	D
R	9.1	9.7	14.9	18.0

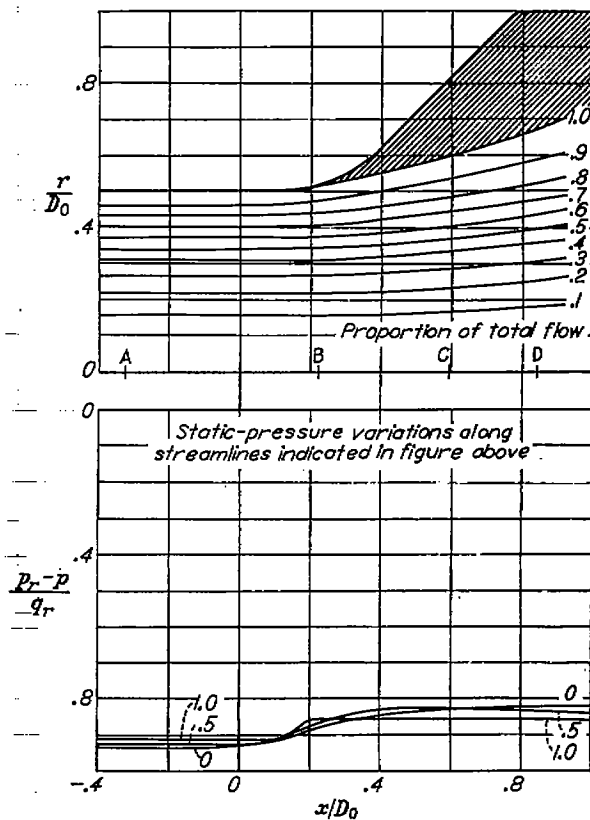
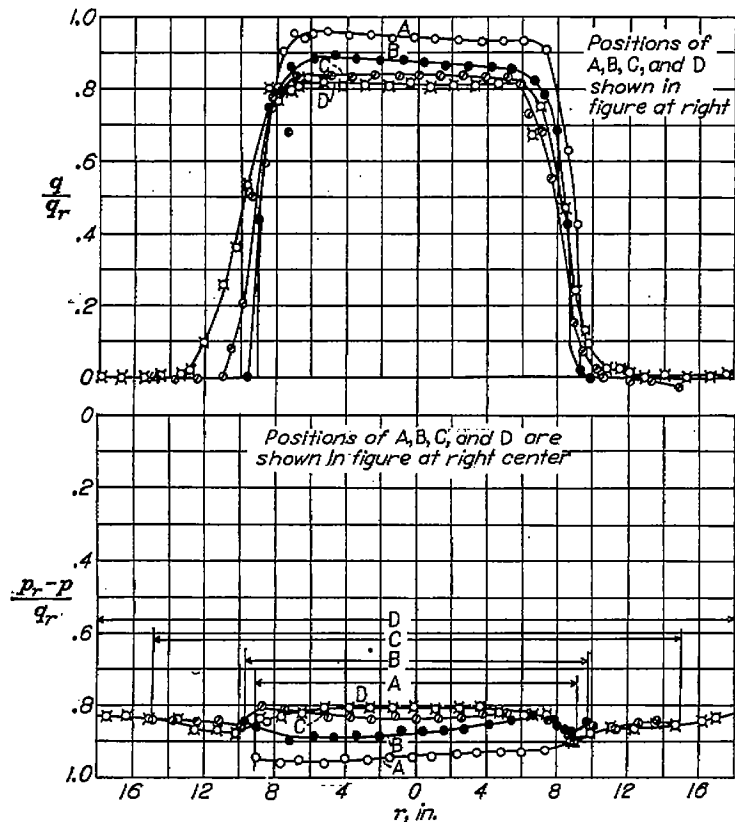
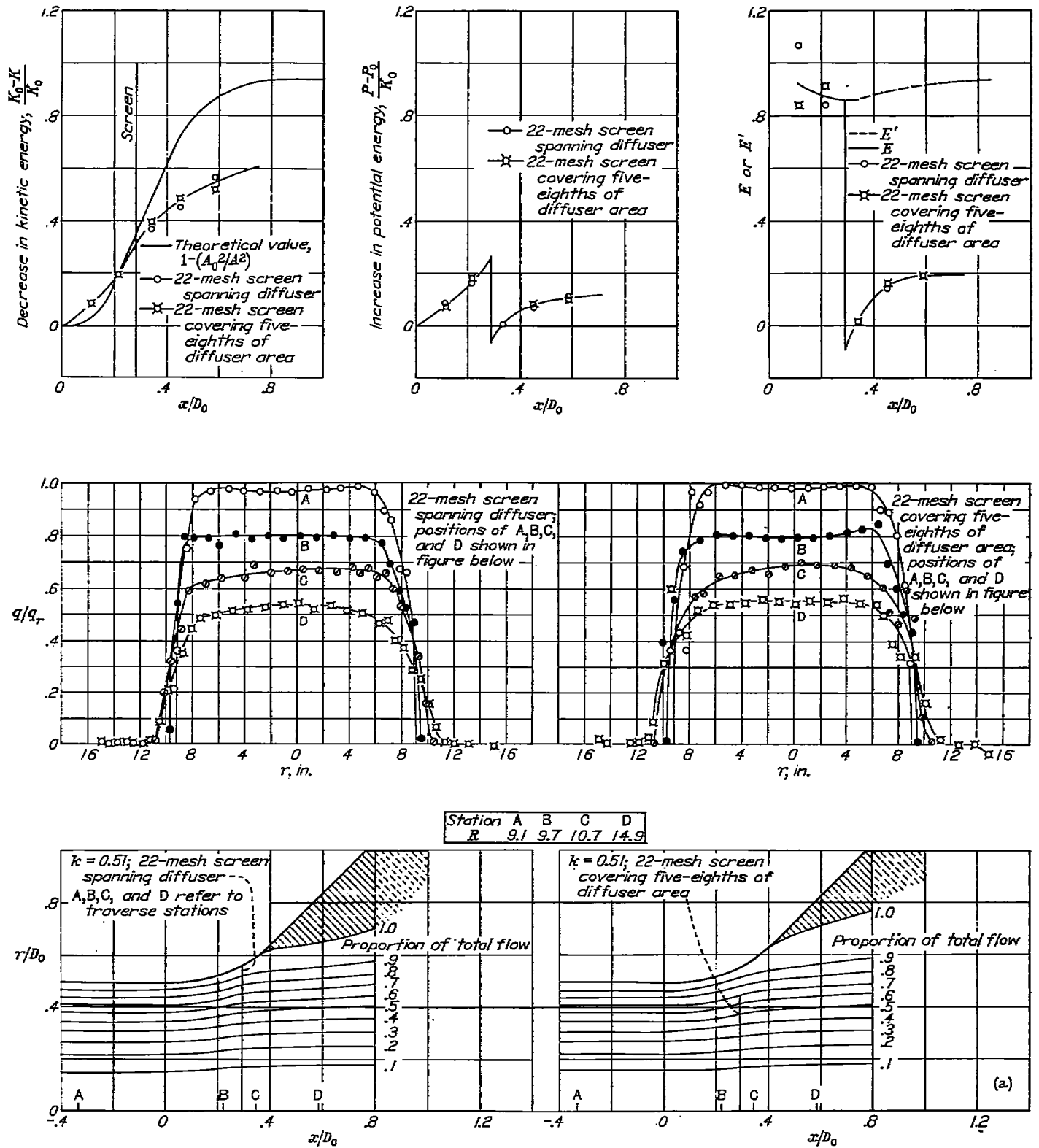
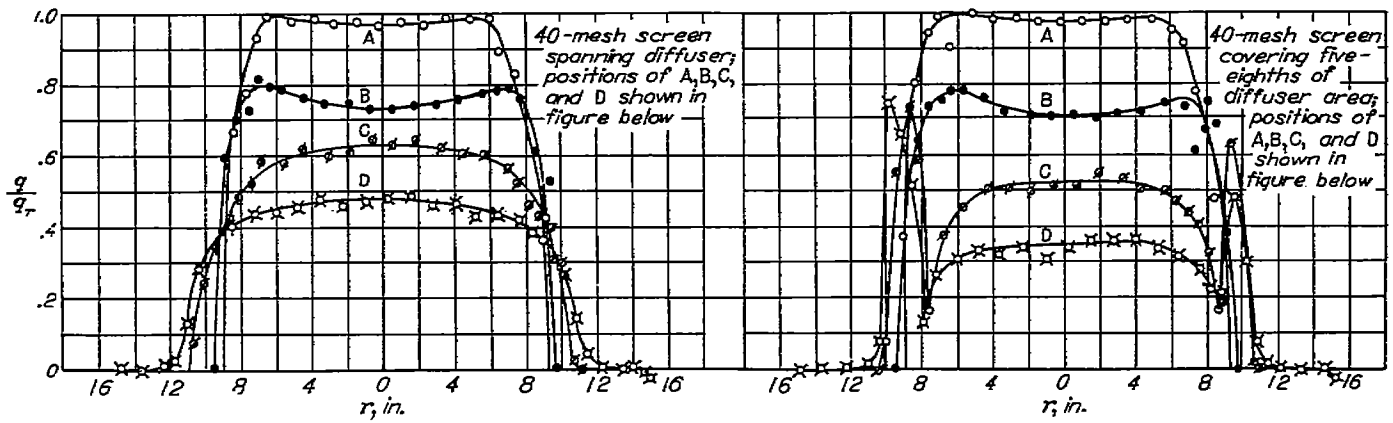
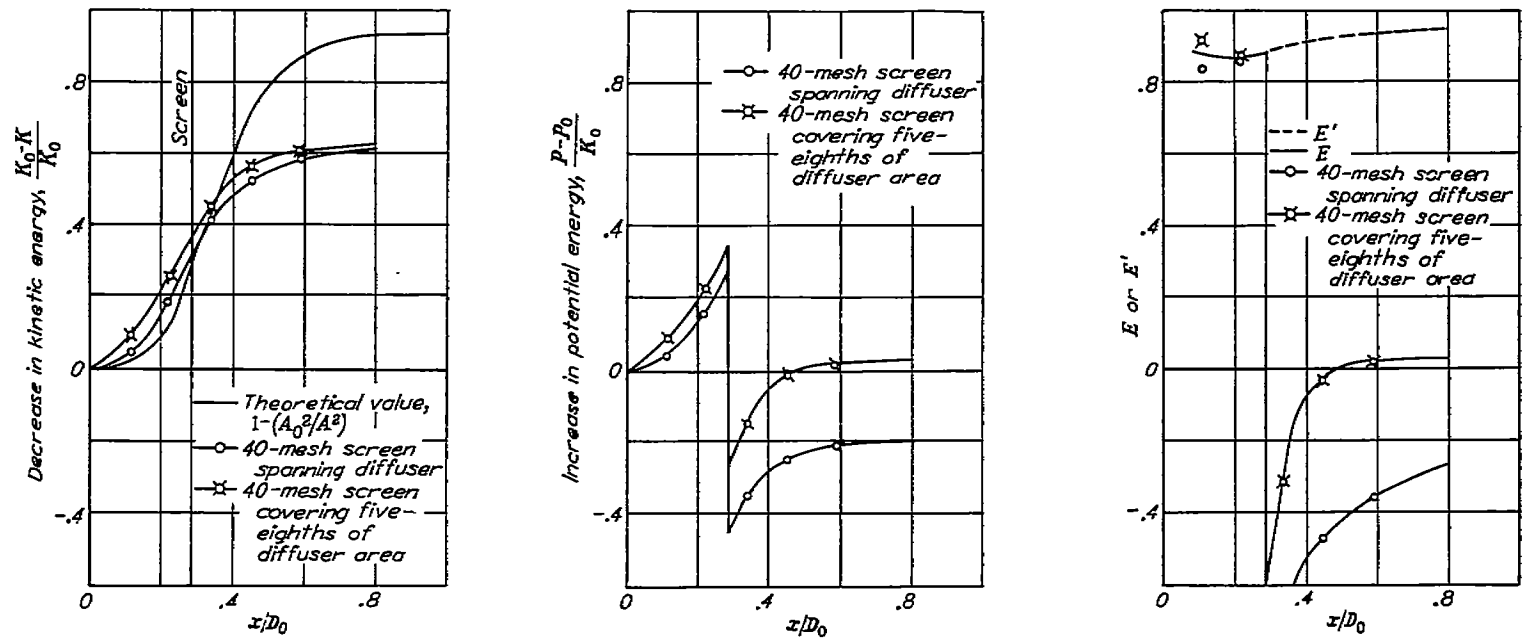

FIGURE 10.—Results of tests of diffuser B without screens. Charts showing changes in kinetic and potential energies, efficiency, dynamic- and static-pressure distributions at various diffuser sections, approximate streamline pattern, and static-pressure distributions along selected streamlines.



(a) Single 22-mesh screen placed 0.29 duct diameter from diffuser entrance. (See also fig. 13 (a).)

FIGURE 11.—Results of tests of diffuser B with a single screen to show effect of annular space between edge of screen and diffuser wall. Charts showing changes in kinetic and potential energies, efficiencies, dynamic-pressure distributions at various diffuser sections, and streamline patterns.



A, B, C, and D refer to  
 traverse stations

Station	A	B	C	D
$R$	9.1	9.7	10.7	14.9

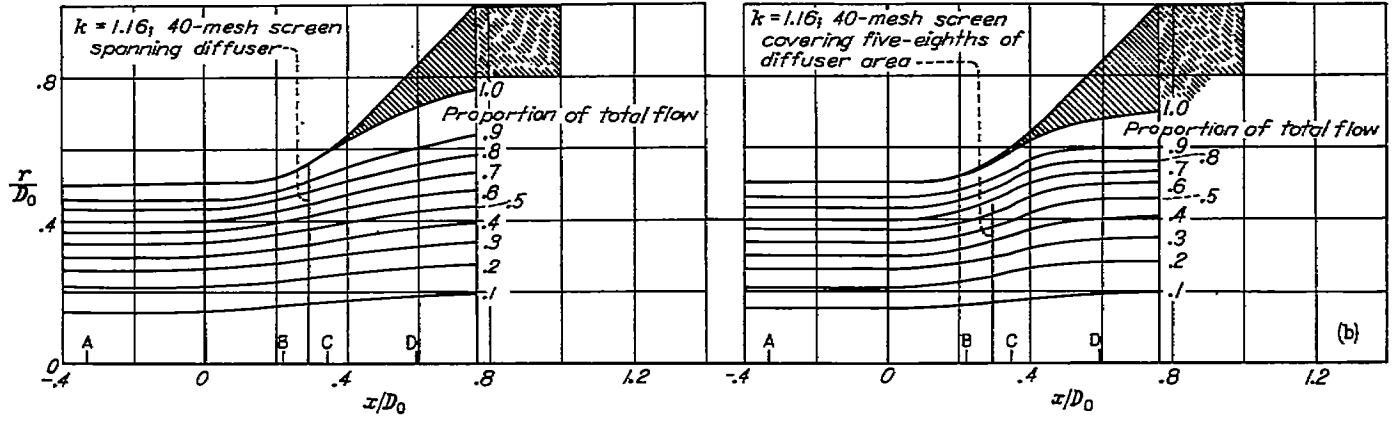

(b) Single 40-mesh screen placed 0.20 duct diameter from diffuser entrance. (See also fig. 12 (b).)

FIGURE 11.—Continued.



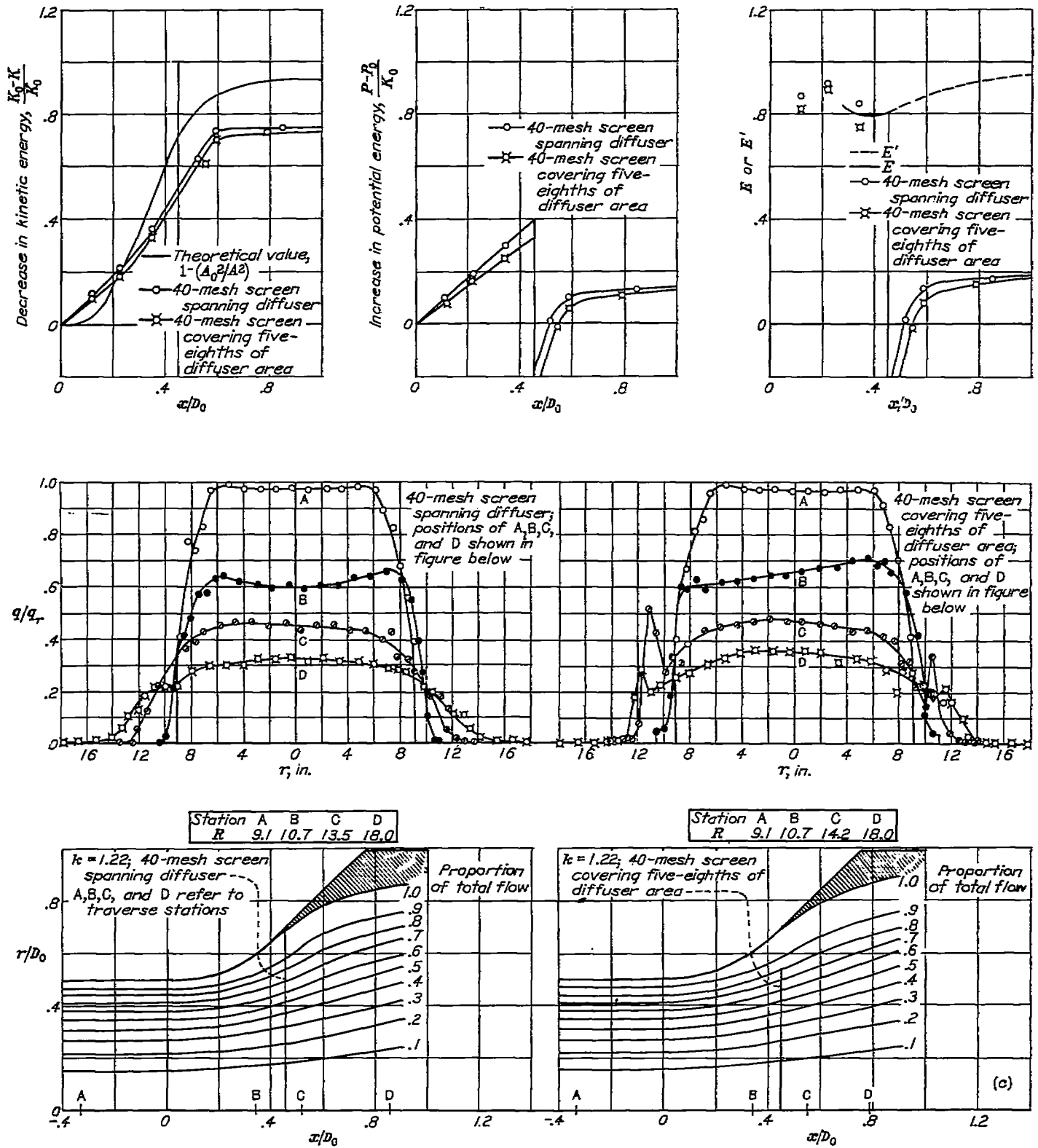

(c) Single 40-mesh screen placed 0.45 duct diameter from diffuser entrance. (See also fig. 12 (c).)

FIGURE 11.—Concluded

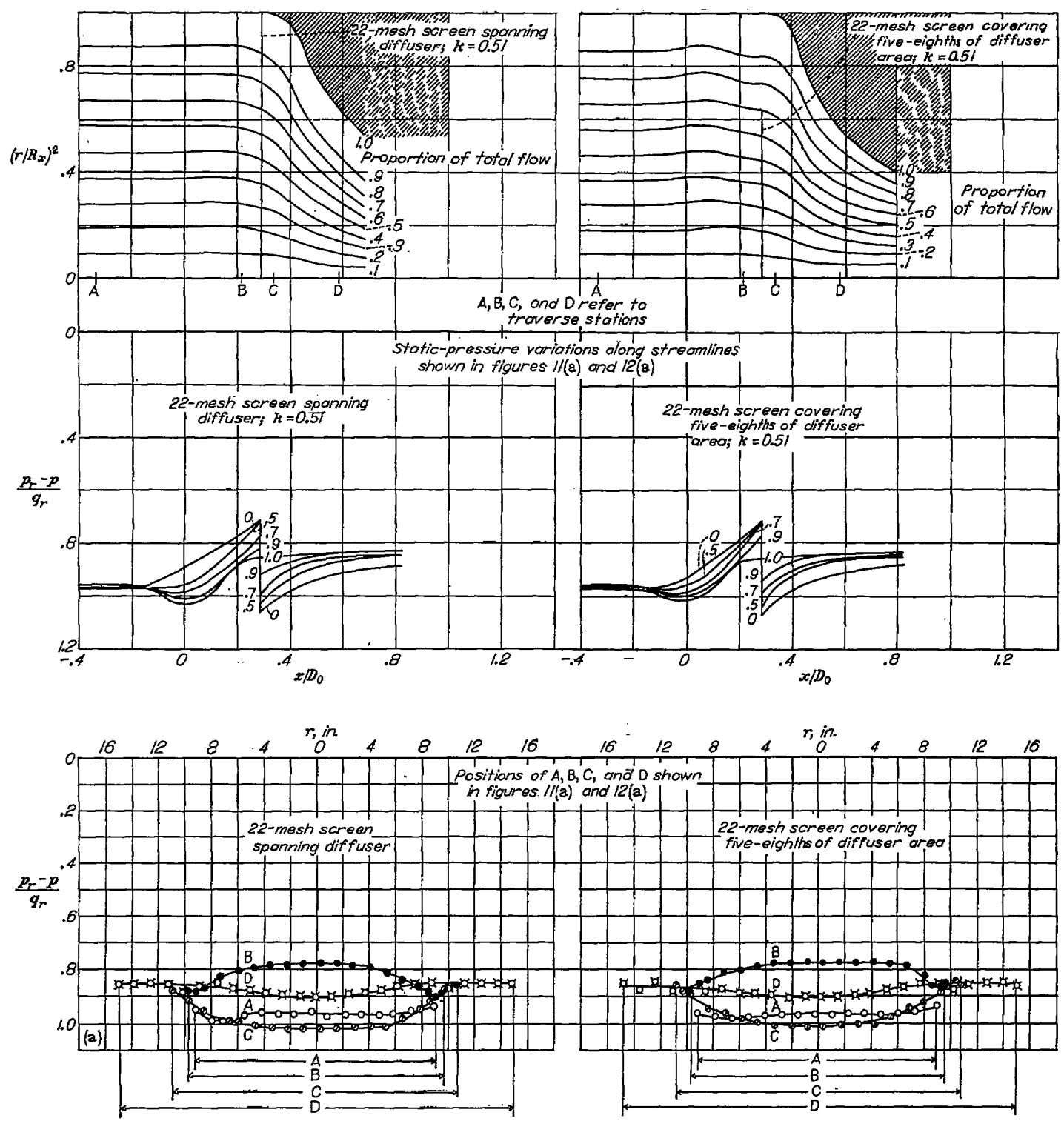

(a) Single 22-mesh screen placed 0.29 duct diameter from diffuser entrance. (See fig. 11 (a).)

FIGURE 12.—Results of tests of diffuser B with a single screen to show effect of annular space between edge of screen and diffuser wall. Charts showing proportion of diffuser area filled by various proportions of total flow, static-pressure variations along selected streamlines, and static-pressure distributions at various diffuser sections.

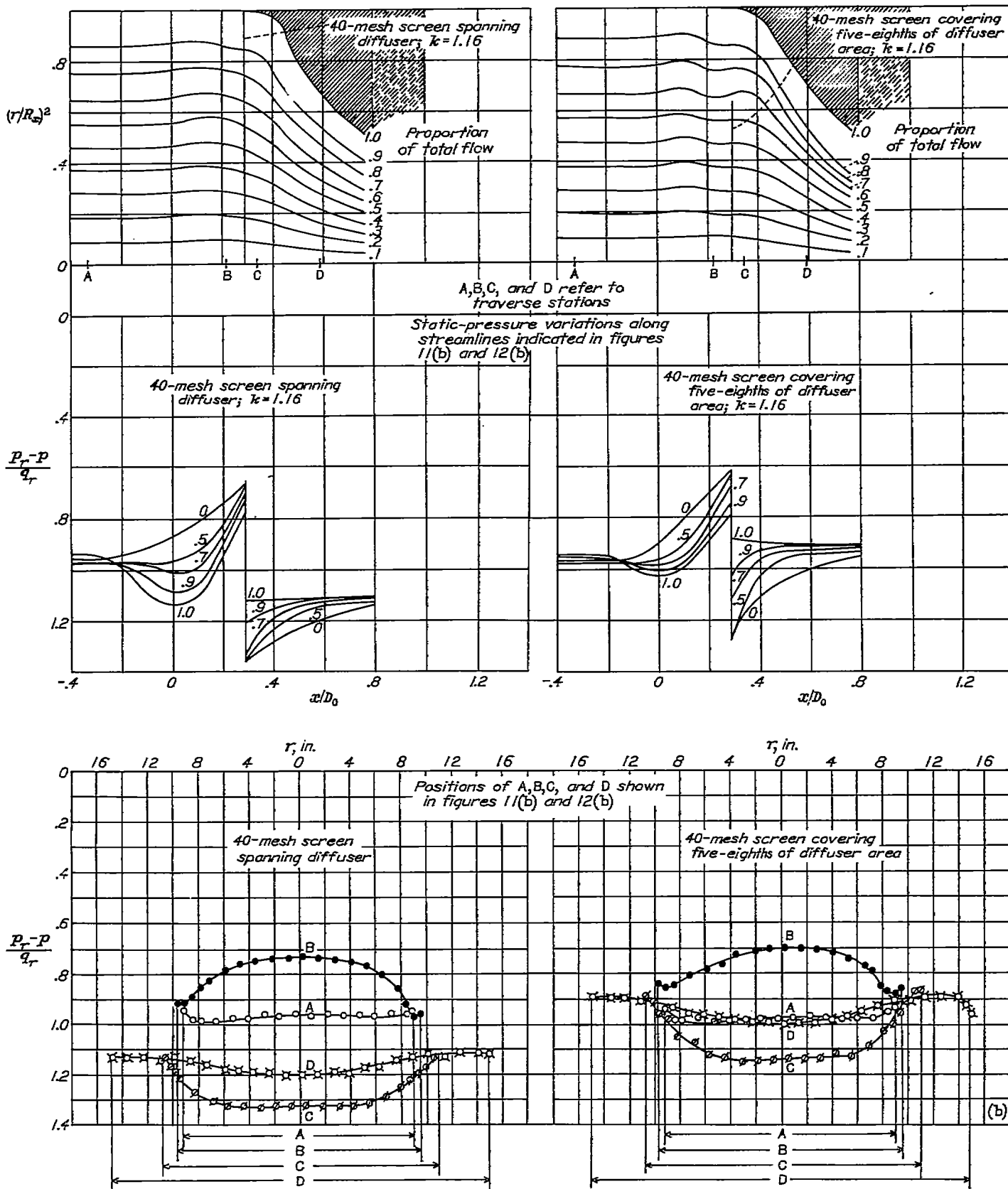
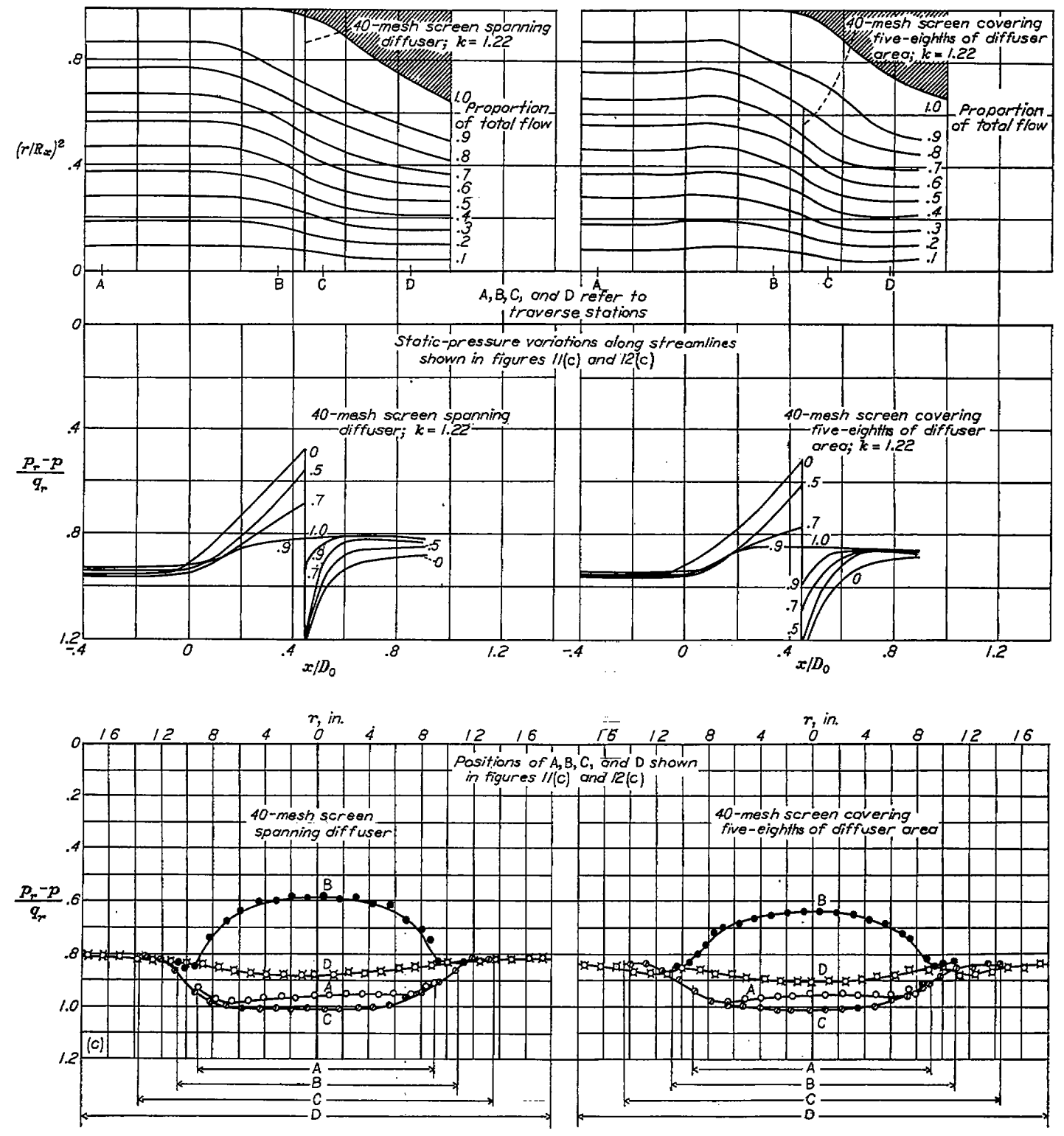

FIGURE 12.—Continued.



(c) Single 40-mesh screen placed 0.45 duct diameter from diffuser entrance. (See fig. 11 (c).)

FIGURE 12.—Concluded.

RESULTS WITH DIFFUSER C

From the results with single screens in diffusers A and B, it was thought that a single screen might be effective in filling a properly shaped diffuser. Diffuser C was constructed to test this hypothesis. Before designing this diffuser, the 18-inch duct was connected to the 36-inch duct to form a so-called 180° diffuser, and a 40-mesh screen was placed about 24 inches downstream from the joint. Measurements were made to determine the outline of the jet approaching and leaving the screen in order to be able later to shape a wall to the "natural" streamlines. A wall thought to be of suitable shape was then constructed, but modifications had to be made by cut-and-try methods until diffuser C was finally obtained.

The results with diffuser C are given in figure 13, which shows that the diffuser remained fairly well filled. The curves of  $q/q_r$  show considerable boundary layer and some asymmetry in the flow at section D.

MECHANICS OF DIFFUSION AIDED BY SCREENS

With the aid of the results presented in the foregoing sections, an attempt is made to explain the mechanics of flow through diffuser-screen combinations. The experiments show characteristic behaviors for which possible explanations are advanced. Previous theories (reference 2 and some informal German literature) deal with the passage of an initially uniform stream through a screen or porous wall. It is apparent now that such theories fail to deal with the real problem. A diffuser problem exists only when there is a nonuniform stream which can become even less uniform in an adverse pressure gradient or when there is a boundary layer which can separate. Of these two, boundary-layer separation is the more important, and the problem may be regarded as a combined boundary-layer and screen problem. This kind of problem is so involved that a theoretical approach has not been possible. Furthermore, a complete theory can hardly be expected until problems of

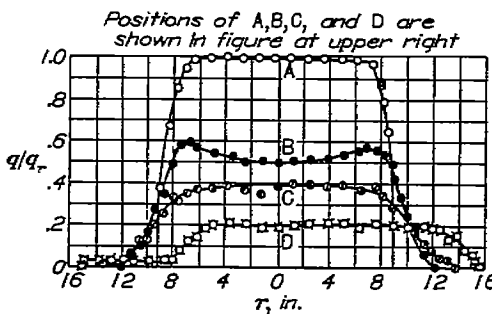
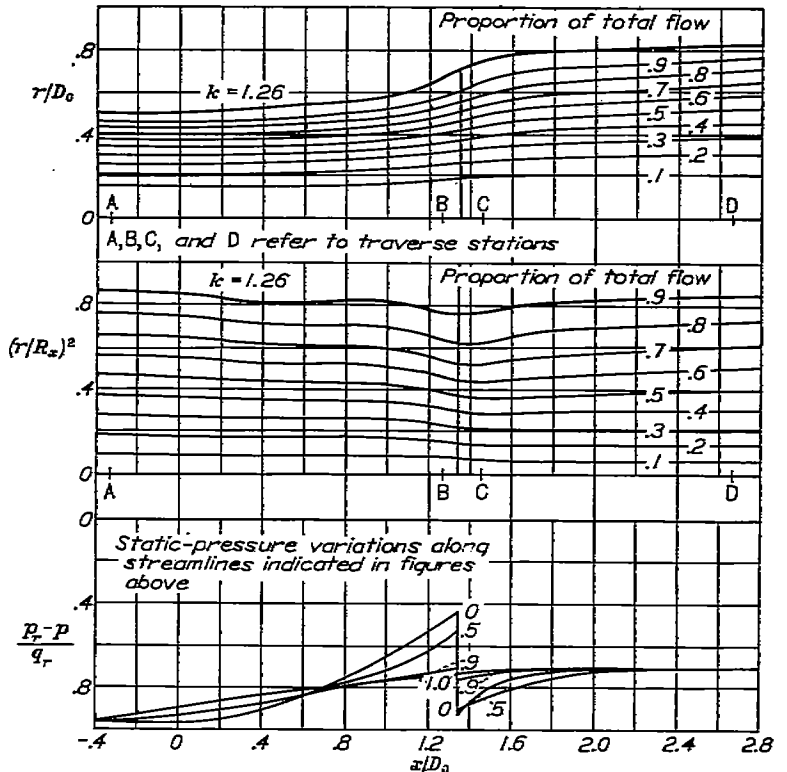
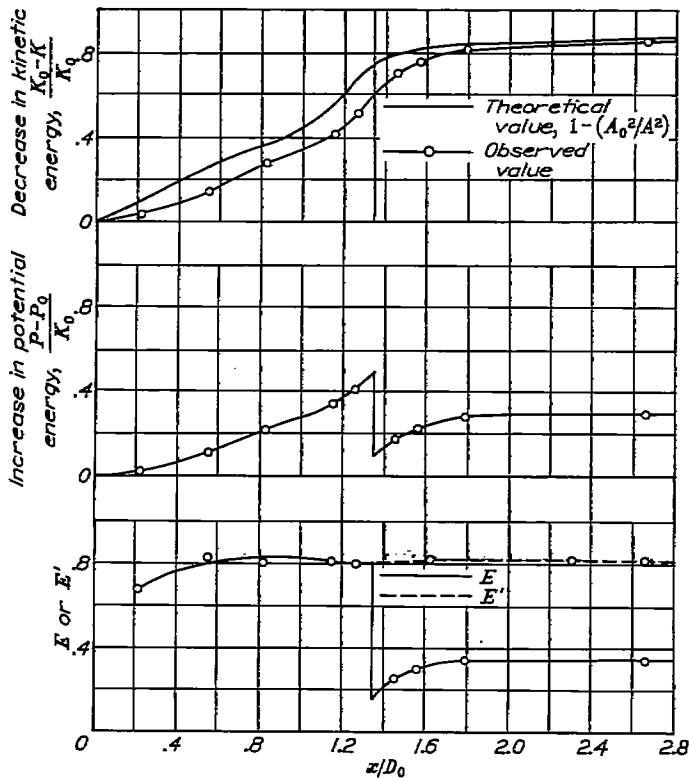

Station	A	B	C	D
$R$	9.1	12.1	13.6	15.1

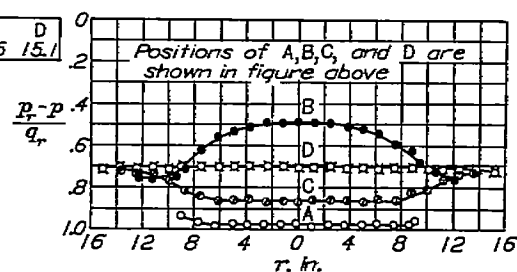

FIGURE 13.—Results of tests of diffuser C with 40-mesh screen.



the turbulent boundary layer and turbulent separation have been dealt with successfully.

It may be well to review the present-day physical picture of turbulent separation. So far as is known, separation never occurs unless the flow is proceeding into a region of higher pressure, that is, unless an adverse pressure gradient exists. Under this condition the fluid near the wall is retarded both by wall friction and by the pressure gradient. Separation occurs when the resultant retarding action is sufficient to bring the flow to rest in the neighborhood of the wall, in spite of the propelling action of the turbulent shearing stresses from regions farther removed from the wall. Turbulent shearing stress bears no simple relation to velocity gradient as does viscous shearing stress, but it increases with velocity gradient. Quantitative relations for these processes are still lacking, but the general picture is helpful, since it shows that separation may be prevented by decreasing the pressure gradient along the surface or by increasing the velocity gradient normal to the surface. The latter is often regarded as equivalent to decreasing boundary-layer thickness, but in some types of velocity distribution boundary-layer thickness has little meaning. The behavior of screens is interpreted in terms of these two effects.

#### FLOW UP TO A SCREEN

It can be observed, for example in figure 7 (c), that a stream diverges as it approaches a screen. To find a reason for this and the conditions on which it depends, consider for the moment a free cylindrical jet impinging against a solid wall. As the wall is approached, the streamlines bend away from the axis and finally become nearly parallel to the wall. Centrifugal pressure gradients accompanying the curvature give rise to pressures which increase toward the axis and toward the wall. The velocities decrease correspondingly in accordance with Bernoulli's law. If the wall is porous, much the same thing happens but to an extent which decreases with increasing porosity.

By thinking now in terms of solidity or parameter  $k$  rather than of porosity, it is obvious that the stream passes through with more and more of the original concentration about the jet axis as  $k$  is decreased. However, not all the jet flow passes through in a finite area unless the jet is constrained as it approaches the screen. A diffuser provides such constraint, and its size and shape are as much a part of the problem of the resulting velocity and pressure field as is the value of  $k$  of the screen.

If the friction effects of a wall could be neglected, the design of a diffuser would be reduced to shaping a wall to conform to any one of the streamlines of a field of flow associated with a given stream approaching a given screen. If friction is now taken into account but regarded as significant only in connection with separation, a streamline would be chosen along which the pressure gradient is too small to cause separation. This was attempted in the design of diffuser C without success. The difficulty was that the boundary layer accompanying the wall modified the velocity distribution and the

pressure field. In short, a successful design was not possible without considering the problem as a whole. A shape may be found by trial and error, as was finally done in the case of diffuser C.

Consider next a diffuser which is not shaped to streamlines along which the pressure gradients are small enough to prevent separation, such as diffuser A. Figure 7 shows that separation always occurs unless a screen is well upstream. It is interesting that a screen does prevent upstream separation without specially shaped walls, and it would be desirable to know the way in which this is accomplished.

Since the pressure gradient is known to be an important factor in separation, examine the pressure distribution along the wall of the diffuser. Figures 6 and 9 show the distribution of static pressure along the streamlines. Where the flow has not separated, the pressure distribution along the 1.0-streamline is identical with that along the wall. Thus in figure 9 (a) the 1.0-curves for the 40- and 50-mesh screens give the pressure distribution along the wall at a distance somewhat beyond the screen. In figure 6 or figures 9 (b) and 9 (c), the 1.0-curve gives the pressure distribution along the wall up to the first separation point, which is in the neighborhood of  $x/D_0=0.4$ . A comparison of the pressure distributions shows that the total increase in pressure up to the 0.4-point is about the same with and without separation, but the rate of rise is much greater at the 0.4-point without separation. Therefore the screen has done nothing to the pressure along the wall that would be expected to prevent separation.

On continuing the examination of the static-pressure variation along streamlines, it is noted that a screen always causes the greatest rise in pressure along the 0-streamline. Attention has been called to this phenomenon in connection with the curvature of the streamlines. In a pressure field of this sort, by Bernoulli's law, the velocity decrease is greatest in the central part of the stream. It follows that air must be diverted toward the walls by the screen. This increases the velocity gradient, and consequently the shearing stress, at the wall. This seems to be a logical explanation for the prevention of separation when the wall is not shaped to promote low pressure gradients.

#### FLOW DOWNSTREAM FROM A SCREEN

It can be observed in figure 7 that separation downstream from a screen may be delayed or even prevented entirely by proper choice of position and value of  $k$ . One reason for this is apparent from figure 9, which shows an inversion of the pressure field at the screen. To the rear of the screen the pressure is lowest at the center and increasing radially. At some distance downstream the radial differences approach zero, the equalization having occurred by the fact that pressure increased most on the 0-streamline. The small rise along the wall accounts for the fact that the flow proceeds for a considerable distance without separation.

The inversion of the pressure field at a screen is accompanied by a reversal in curvature of the streamlines and by a



reversal of the radial velocity components. This process is influenced somewhat by the shape of the walls. In diffuser C the curvature of the wall was reversed at the screen, in keeping with the reversal in the curvature of the streamlines. Since the radial velocity gradients near the wall are low for diffuser C, the pressure gradients along the wall must be kept very small to avoid separation. Consequently the diffuser angle is wide only in the neighborhood of the screen.

**MULTIPLE SCREENS**

The performance of single screens in diffuser A suggests that it may be possible to prevent separation throughout the whole of the diffuser by using more than one screen. Effects upstream and downstream from screens are then superposed. As far as separation and filling are concerned, it would appear that multiple screens in a diffuser of arbitrary shape can be as effective as a single screen in a diffuser of special shape. It is easier to design a diffuser of simple shape and provide for filling it by proper choice and number of screens than to design a diffuser of special shape.

**PROBABLE EFFICIENCIES**

It can be seen in figure 6 that the efficiency  $E$  decreases with the distance downstream. Estimates based on uncertain measurements indicate an efficiency of about 30 percent at the downstream end. For single screens in various positions, figure 7 shows that  $E$  at the downstream end ranges from 14 to 42 percent, the amount depending on the position and the value of  $k$ . Certainly a screen can reduce efficiency, and apparently a screen cannot be expected to produce much of an increase. However, the values of flow efficiency  $E'$  range from 80 to 90 percent at the downstream end; this indicates that a screen promotes flow efficiency even though separation is not entirely eliminated and filling is not complete.

Flow efficiency depends primarily upon the absence of eddy losses and so must increase with the reduction of dead-air space. This is demonstrated by the rise from 30 percent when the dead-air space was extensive to 80 or 90 percent when the dead-air space was limited by the action of a screen ( $E$  without screens may be compared with  $E'$  with screens). It is apparent that the major gain is achieved by reducing the dead-air space to a relatively small volume and that complete filling could not produce much additional gain.

It is emphasized that filling has different effects on  $E'$  and  $E$ . On considering first  $E'$ , both the numerator and the denominator of equation (2) increase with filling. For  $E$ , however, the numerator contains negative pressure-drop terms for the screens, and these terms are not affected appreciably by filling. They may be large to produce filling, but their effect on  $E$  is lessened by an accompanying increase in the denominator, that is, by increasing the degree of filling.

It may be assumed that  $E'$  has a nearly constant value of about 0.9 when the arrangement of screens is adequate to produce filling. Therefore it should be possible to predict  $E$  by taking into account the pressure drop through the

screens. However, when nothing is known about the distribution of  $p$  and  $q$ , the calculation must be based on equation (1), which unfortunately gives the correct result only when  $p$  and  $q$  are uniform over each section. Nevertheless equation (1) is a fair approximation when the diffuser is filled and may be used for estimating purposes. The use of multiple screens is anticipated and the efficiency relation is set up on this basis.

On referring to figure 14 and considering the efficiency in stages, let  $E_{0,1}$  be the efficiency from section 0 to the downstream side of screen 1,  $E_{1,2}$  be the efficiency from the downstream side of screen 1 to the downstream side of screen 2, and so on. Then, according to equation (1),

$$\left. \begin{aligned} E_{0,1} &= \frac{p_1 - p_0}{q_0 - q_1} \\ E_{1,2} &= \frac{p_2 - p_1}{q_1 - q_2} \\ E_{2,3} &= \frac{p_3 - p_2}{q_2 - q_3} \\ &\dots\dots\dots \end{aligned} \right\} \quad (3)$$

Since the over-all efficiency is

$$E_{0,n} = \frac{p_n - p_0}{q_0 - q_n}$$

it follows by substitution and rearrangement that

$$E_{0,n} = E_{0,1} \frac{1 - \frac{q_1}{q_0}}{1 - \frac{q_n}{q_0}} + E_{1,2} \frac{q_1 - q_2}{q_0 - q_2} + E_{2,3} \frac{q_2 - q_3}{q_0 - q_3} + \dots \quad (4)$$

It follows from equation (3) and the definition of  $E'$  that

$$\left. \begin{aligned} E_{0,1} &= E' - \frac{\Delta p_1}{q_0 - q_1} \\ E_{1,2} &= E' - \frac{\Delta p_2}{q_1 - q_2} \\ &\dots\dots\dots \end{aligned} \right\} \quad (5)$$

where  $\Delta p_1$ ,  $\Delta p_2$ , and so forth are the pressure drops across screens 1, 2, and so forth. By neglecting effects of varying angles of incidence at the screen, it follows from the definitions that  $\Delta p_1 = k_1 q_1$ ,  $\Delta p_2 = k_2 q_2$ , and so forth. From which

$$\left. \begin{aligned} E_{0,1} &= E' - \frac{k_1}{\frac{q_0}{q_1} - 1} \\ E_{1,2} &= E' - \frac{k_2}{\frac{q_1}{q_2} - 1} \\ &\dots\dots\dots \end{aligned} \right\} \quad (6)$$

If the  $q$ 's are uniform over each section, their ratios may be expressed in terms of area ratios, and equations (4) and (6) become, respectively,

$$E_{0,n} = E_{0,1} \frac{1 - \left(\frac{A_0}{A_1}\right)^2}{1 - \left(\frac{A_0}{A_n}\right)^2} + E_{1,2} \frac{\left(\frac{A_0}{A_1}\right)^2 - \left(\frac{A_0}{A_2}\right)^2}{1 - \left(\frac{A_0}{A_n}\right)^2} + \dots$$

$$E_{2,3} \frac{\left(\frac{A_0}{A_2}\right)^2 - \left(\frac{A_0}{A_3}\right)^2}{1 - \left(\frac{A_0}{A_n}\right)^2} + \dots \quad (7)$$

$$\left. \begin{aligned} E_{0,1} &= E' - \frac{k_1}{\left(\frac{A_1}{A_0}\right)^2 - 1} \\ E_{1,2} &= E' - \frac{k_2}{\left(\frac{A_2}{A_1}\right)^2 - 1} \\ \dots &\dots \dots \end{aligned} \right\} \quad (8)$$

In order to use these equations, it is necessary to make some guess about the value of  $E'$ , say 0.9. The number of screens, the value of  $k$ , and some desired efficiency are then chosen, and the positions for the screens are calculated by equations (7) and (8). The proper choice of screens to produce filling cannot be determined in advance; if it is found by test that the diffuser is not filled, more screens having a lower value of  $k$  may be substituted to maintain the estimated efficiency.

In connection with efficiencies to be expected, it is well to point out a few obvious facts. The highest efficiency always is obtained in a narrow-angle diffuser without screens. According to Patterson (reference 4), the highest efficiencies are obtained in conical diffusers of area ratios up to 4 to 1 when the total included angle is about  $8^\circ$ , and then the highest efficiency to be expected is around 90 percent. The efficiency decreases with increasing initial boundary-layer thickness, so 90 percent is only a nominal value. Also the optimum angle is less for greater area ratios. It is convenient, however, to think in terms of an  $8^\circ$  angle and a 90-percent efficiency in connection with narrow-angle diffusers; it should be remembered, of course, that there is nothing very exact about either the angle or the efficiency. As the angle increases the efficiency decreases, slowly at first, and separation of the flow soon becomes imminent. If the angle is increased and screens are introduced to prevent separation, the efficiency must again drop because  $E'$  cannot be expected to exceed 90 percent and  $E$  must be less than  $E'$ . Obviously there is no lower limit to  $E$ .

If a screen of given value of  $k$  is to be introduced, the loss in efficiency is a minimum when the screen is placed at the extreme downstream end of a narrow-angle diffuser. It then becomes possible to widen the angle just ahead of the

screen and increase the area ratio. In order to take full advantage of the screen, the widening should be continued as far as possible to the rear of the screen. This means that the area ratio is increased first without additional length by the flare in front of the screen and second with additional length by the wide-angle extension to the rear of the screen. For a given area ratio and a given value of  $k$  the most efficient diffuser employing a screen is a narrow-angle diffuser terminating in a wide angle like diffuser C.

Next consider a screen placed not near the end but at some position farther upstream where the cross section is smaller, and again consider the walls formed into a short section of wide-angle diffuser in the vicinity of the screen. If the value of  $k$  is the same as in the previous example, the stream patterns are similar and the increase in area in the wide-angle section is in each case proportional to the area of the screen. Therefore the upstream screen produces the smaller area increment. Furthermore the loss in efficiency is greater because of the greater pressure drop at the screen. If the installing of screens is continued, each with its wide-angle portion, the original narrow-angle diffuser is effectively converted into a wide-angle diffuser. This process can result in an increased area ratio or a shortened diffuser with the original area ratio. Obviously a continuous widening may be substituted for the stepwise widening if there is a sufficient number of screens. Each addition of a screen has decreased the efficiency, and the efficiency has therefore decreased with widening of the angle.

By using the foregoing example, the efficiency may be examined in a different light to get some idea of the probable upper limit of efficiency. It can be observed in figures 9 and 13 that in no case does the over-all increase in static pressure in the central part of the stream exceed that along the walls. The only way then for the efficiency to be greater than zero is to have a net gain in pressure along the walls. The foregoing example is convenient for the reasoning that follows, for, just as in diffuser C, each screen is assumed to reduce the pressure gradient sufficiently to prevent separation. The maximum permissible pressure gradient along the walls is not known, but it is reasonable to suppose that it could not be materially different from that along the walls of an  $8^\circ$  diffuser with the same area ratio as some wide-angle diffuser in question. If it is the same, the ratio of the efficiency of a wide-angle diffuser to that of an  $8^\circ$  diffuser with the same area ratio is equal to the ratio of their respective wall lengths. By taking this ratio and assuming the efficiency of an  $8^\circ$  diffuser to be 90 percent, the predicted maximum efficiencies of diffusers A, B, and C are:

Diffuser	Maximum efficiency (percent)	
	Predicted	Observed
A.....	26	-----
B.....	9	-----
C (wide-angle portion only).....	30	24

According to the foregoing reasoning the upper limit of efficiency is determined by the wall length. Nothing in the experiment is in conflict with this conclusion. In one case the efficiency of diffuser A was found to be 42 percent, but in this case the diffuser was far from being filled. When a wide-angle diffuser is filled in the sense that the velocity is relatively high near the walls, the adverse pressure gradient may be higher along the walls than it could be in an 8° diffuser; but in all such cases there will be an abrupt drop in the pressure on the wall at a screen. These drops can reduce the efficiency without limit, the reduction depending on the number and the value of  $k$  of the screens. It should be borne in mind that the present argument concerns the probable upper limit of efficiency.

Obviously screens are not the proper devices to obtain high efficiency. Screens are generally considered in applications when efficiency is not of primary importance, such as the wind-tunnel application taken up in the following section.

Even if screens are not used, it is always desirable to make the contraction ratio across the entrance cone as large as possible, and this is usually accomplished in return-circuit tunnels by composing the return circuit of narrow-angle diffusers. As mentioned in the "Introduction," it was found that when damping screens were used, the contraction ratio could be further increased without lengthening the tunnel by terminating the narrow-angle diffuser with a short section of wide-angle diffuser. This is illustrated schematically in figure 14, where for the present purpose multiple screens are shown. Without the wide-angle diffuser the contraction ratio would be  $A_0/A_1$ . With the wide-angle diffuser the contraction ratio is  $A_n/A_1$ .

When screens are used solely for the reduction of turbulence, the aim is to use as many screens as possible or as high a value of  $k$  as is consistent with the allowable reduction in energy ratio of the tunnel. Obviously the power consumed in pressure drop across screens always is reduced by the addition of the wide-angle diffuser. It is just as obvious

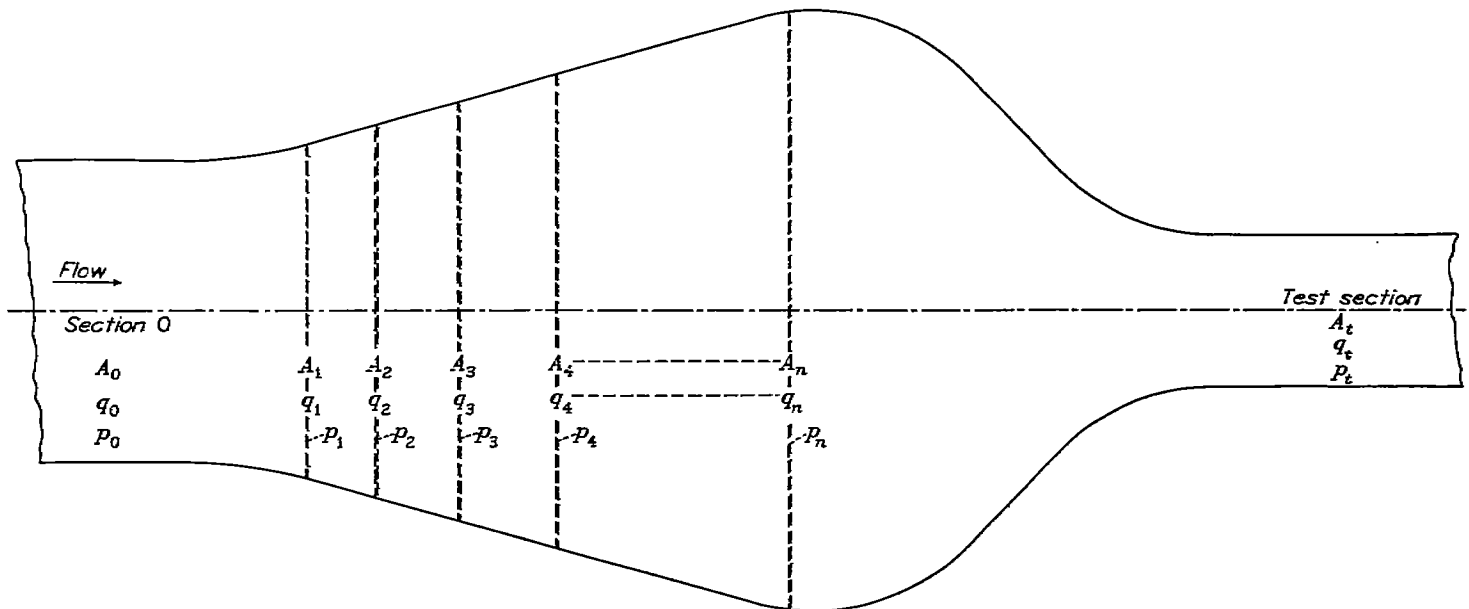

FIGURE 14.—Schematic diagram showing possible application of a diffuser-screen combination to a wind tunnel.

**EXPERIMENTS WITH MULTIPLE SCREENS**

**REMARKS ON APPLICATION TO DAMPING SCREENS**

Experiments with multiple screens in diffusers A and B were carried out with a particular application in mind, namely, the use of damping screens in wind tunnels to reduce turbulence. One of the objects was to confirm the conclusion that even a very wide-angle diffuser (diffuser B) could be filled by using screens. The reasons for the screen arrangements are given in the following paragraphs.

As described in reference 5, damping screens are effective devices for reducing wind-tunnel turbulence when they are placed upstream of the test section of a tunnel. For reasons of power economy the screens are placed ahead of the entrance cone where the velocity of the stream is a minimum.

that the use of screens always entails some expenditure of power. The question now is the amount of power to be expended in the screens. In order to find a reasonable answer to this question, it is assumed that in most modern wind tunnels the ratio  $A_0/A_1$  is 4 or more. If so,  $q_0/q_1$  is  $1/4$  or less, and it is assumed that the complete loss of  $q_0$  is not too great a price in power consumption to pay for the privilege of using screens. It is reasonable therefore to require only that there shall be no drop in static pressure across a diffuser-screen combination. This means that the ratio  $A_n/A_0$  may be as large as desired and that the over-all efficiency of the wide-angle diffuser is to be zero.

Since the purpose of damping screens is to reduce turbulence, it is of paramount importance that there be no flow

separation in the wide-angle diffuser. It is also important to have the mean velocity uniform at the exit of the wide-angle diffuser. Since the proper design of a diffuser to prevent separation with a single screen is a difficult matter, multiple screens in a simple diffuser were believed to be the practical answer to the separation problem. Various numbers of screens were therefore tried in diffusers A and B.

The original intention when the screens were installed was to aim for an over-all efficiency of zero. This work was done before the significance of  $E'$  was realized, and it was assumed that it would be permissible to attribute all losses to the screens. Accordingly a zero efficiency for each stage (each screen) was calculated by use of equation (8) by assuming  $E'=1$ . This gave the following relations for the cross-sectional areas in which the screens were to be placed:

$$\left. \begin{aligned} \frac{A_1}{A_0} &= (k_1 + 1)^{1/2} \\ \frac{A_2}{A_1} &= (k_2 + 1)^{1/2} \\ &\dots \dots \dots \end{aligned} \right\} \quad (9)$$

For the over-all area ratio,

$$\frac{A_n}{A_0} = (k_1 + 1)^{1/2} (k_2 + 1)^{1/2} \dots (k_n + 1)^{1/2} \quad (10)$$

And if the  $k$ 's for all screens are identical, equation (10) reduces to

$$\frac{A_n}{A_0} = (k + 1)^{n/2}$$

which states that, since the area ratio of the diffuser is specified, the number of screens necessary to attain zero efficiency is fixed by  $k$ . Insofar as this relation is concerned, a single screen having a high value of  $k$  would give the same result as several screens, each with a low value of  $k$ . However, separation of flow within the diffuser is determined not only by the flow pattern of the stream, area ratio, value of  $k$  of the screen, and number of screens, but also by the screen spacing. The tests showed that the first screen, even a screen having a high value of  $k$ , must be placed well upstream in the diffuser to prevent separation. It is therefore apparent that, if a given efficiency is to be maintained without flow separation, not only must equation (9) be satisfied, but also the diffuser length up to the first screen, or between successive screens, must be limited. This effectively limits the upper value of  $k$  for the screens in any particular diffuser.

An interesting result follows from equation (10) and the relations for damping screens given in reference 5. According to reference 5, the turbulent fluctuations are reduced on passing through a screen in the ratio

$$\frac{1}{(k + 1)^{1/2}}$$

and if several screens are used in tandem with a spacing of several inches or more between them, the fractional reduction over the group is

$$f = \frac{1}{(k_1 + 1)^{1/2} (k_2 + 1)^{1/2} \dots (k_n + 1)^{1/2}} \quad (11)$$

It follows from equations (10) and (11) that

$$f = \frac{A_0}{A_n} \quad (12)$$

Equation (12) states that the reduction of turbulence is independent of the number of screens and the value of  $k$ ; that is, it depends only on the area ratio of the wide-angle diffuser. The physical explanation of equation (12) is that, when screens are positioned by the relations given by equation (9), the fall in mean velocity from screen to screen is the same as the reduction in turbulence across each screen. For the diffuser as a whole the mean velocity is reduced in the same ratio as the fluctuations; this results in a decrease in absolute turbulence, but the percentage turbulence in section  $n$  after the last screen is the same as in section 0. If the absolute turbulence remains constant as the stream is accelerated in passing through the entrance cone, the ratio of the absolute turbulence to the mean speed, or percentage turbulence, must decrease with the increase in speed. Any reduction in percentage turbulence in the test section must result either from additional screens placed in or at the exit of the diffuser or from the larger contraction ratio made possible by the diffuser. In this treatment a possible effect of expansion and contraction on the fluctuations has been neglected. Some discussion of this subject can be found in reference 5.

**RESULTS FOR MULTIPLE SCREENS**

The main results for multiple screens are given in figures 15 (a), 15 (b), and 15 (c) for diffuser A and in figures 16 (a) and 16 (b) for diffuser B. Inspection of these figures shows that there is slight separation only with the two 54-mesh and one 30-mesh combination in diffuser B. Separation was not prevented with this combination because the lengths ahead of the first screen and between successive screens were too great. The value of  $k$  of the 54-mesh screen is obviously too high to satisfy equation (9) when it is placed in a position sufficiently far upstream to prevent separation. In general the filling ahead of the first screen improves with the number of screens because the first screen is then placed farther upstream in accordance with the relations of equation (9), but beyond the first screen the number of screens has little effect on the filling. The dynamic pressure is remarkably uniform at the downstream end of diffuser A, as shown in figure 15 (b). For diffuser B, as shown in figure 16 (b), it is only slightly less uniform.

On considering the efficiencies shown in figures 15 (a) and 16 (b), it can be observed that over-all efficiencies were less



than zero and not all values were the same. There are several reasons for this. On considering diffuser A first, it is seen in figure 15 (a) that the over-all efficiencies range from -5 to nearly -15 percent. This is partly accounted for by the fact that  $E'$  is between 90 and 95 percent instead of 100 percent as assumed. Most of the remainder and the dispersion in values are caused by failure of the position of the final screen to come at the downstream end of the diffuser. This meant putting in too many 30-mesh screens and too few 40-mesh screens. The six 22-mesh screens were about right, but these screens were all shifted downstream slightly in an effort to bring the over-all efficiency nearer to zero. It is remarked that the efficiency may always be improved by moving screens to larger cross sections, and this is permissible as long as filling is not impaired. With the six 22-mesh screens it is believed that the filling ahead of the first screen would have been satisfactory even if the screens had been shifted far enough to give an efficiency slightly above zero.

For diffuser B, five 30-mesh screens are too many and three

40-mesh screens are too few, as in diffuser A. The two 54-mesh and one 30-mesh combination is about right. Figure 16 (b) shows that the over-all efficiency with the right number of screens is about -25 percent. Approximately -10 percent can be accounted for by an  $E'$  of 90 percent, but -15 percent must be accounted for in some other way. In these cases the pressure drop through the screens is greater than the calculated drop because of the angle at which the flow passed through some portions of the screens. Figure 16 (a) shows angles to the normal as much as  $45^\circ$ .

The abnormally high pressure drop through screens in diffuser B is illustrated in figure 17, where a comparison is shown between diffusers A and B for the 30- and 40-mesh screens. The values of  $k$  for the screens are labeled the same in each diffuser because they would be the same for normal flow incidence. However, in diffuser B the effective value of  $k$  is seen to be about doubled for all but the first screen because of the angle of flow. For diffuser A the departure from normal incidence is not sufficient to produce a significant effect.

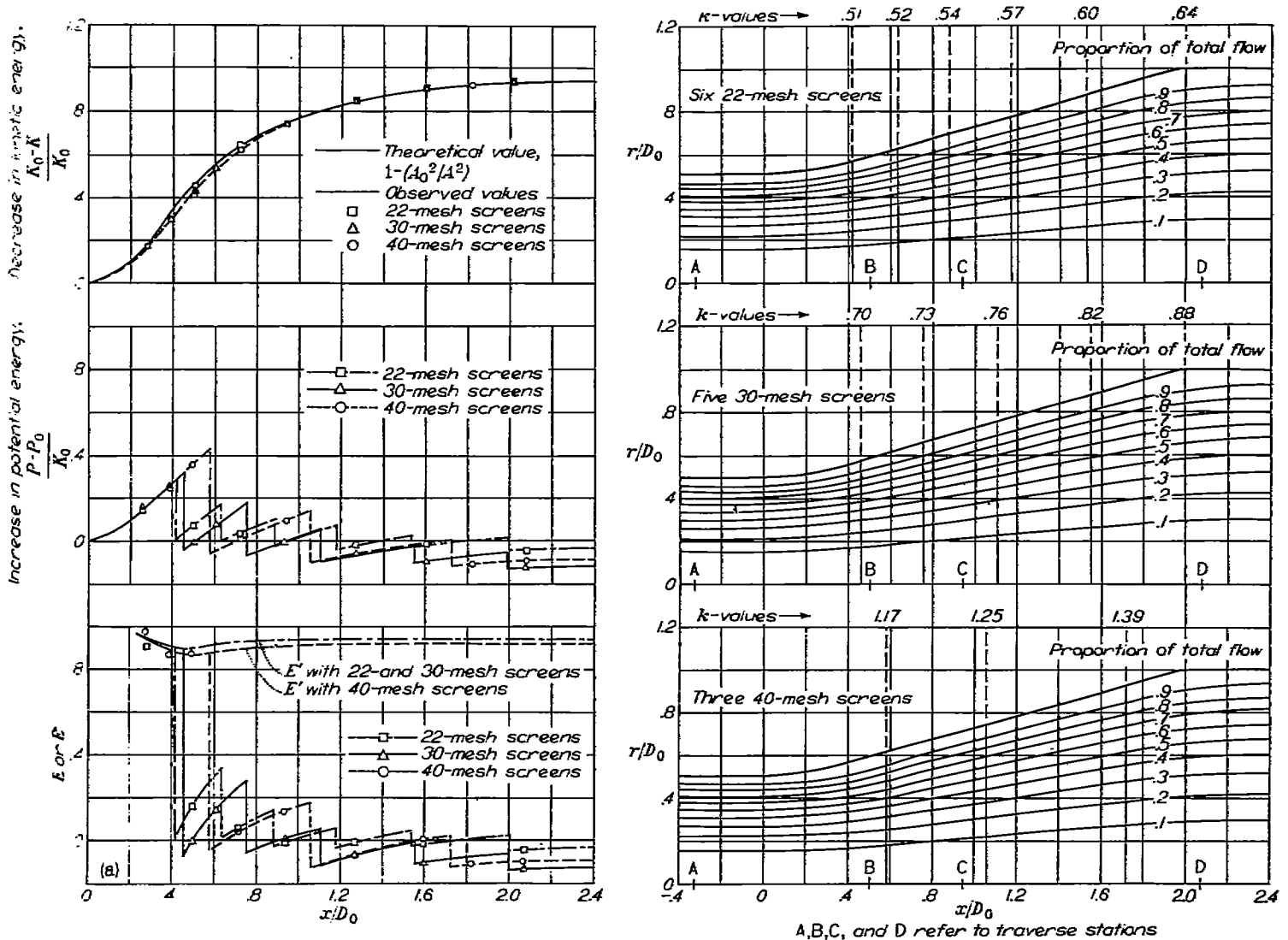

(a) Charts showing changes in kinetic and potential energies, efficiencies, and streamlines.

FIGURE 15.—Results of tests of diffuser A with various multiple-screen combinations.

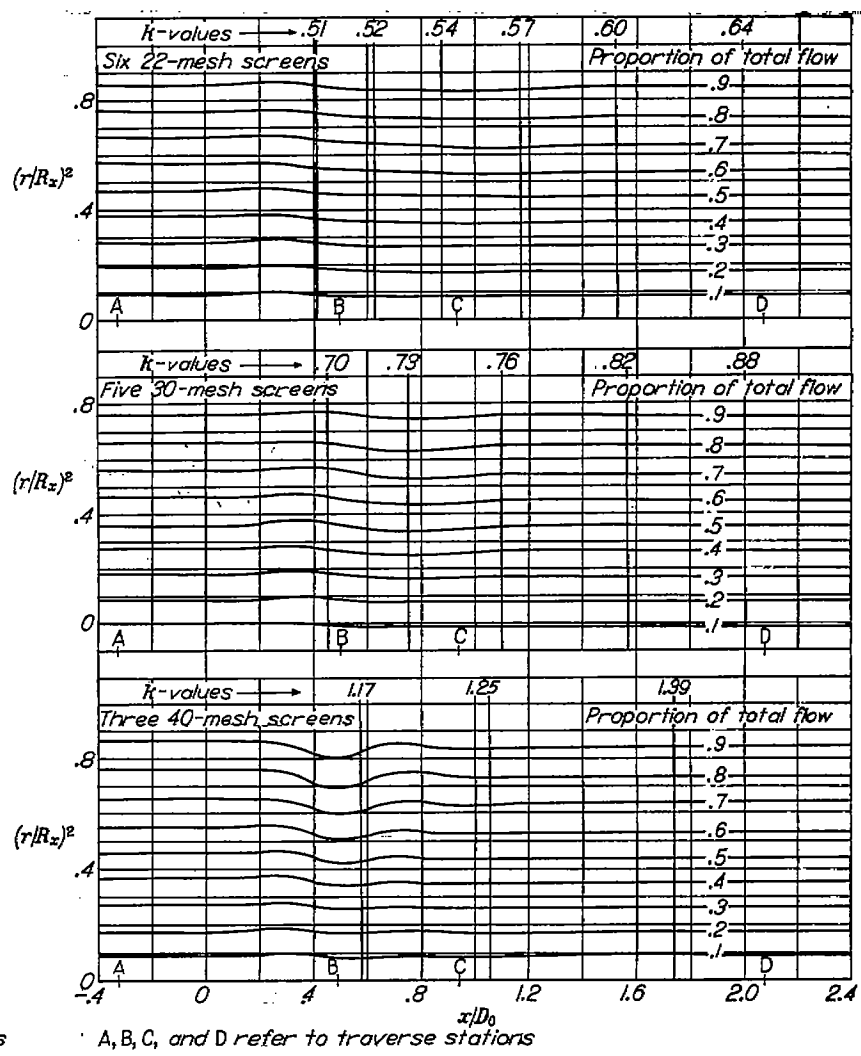
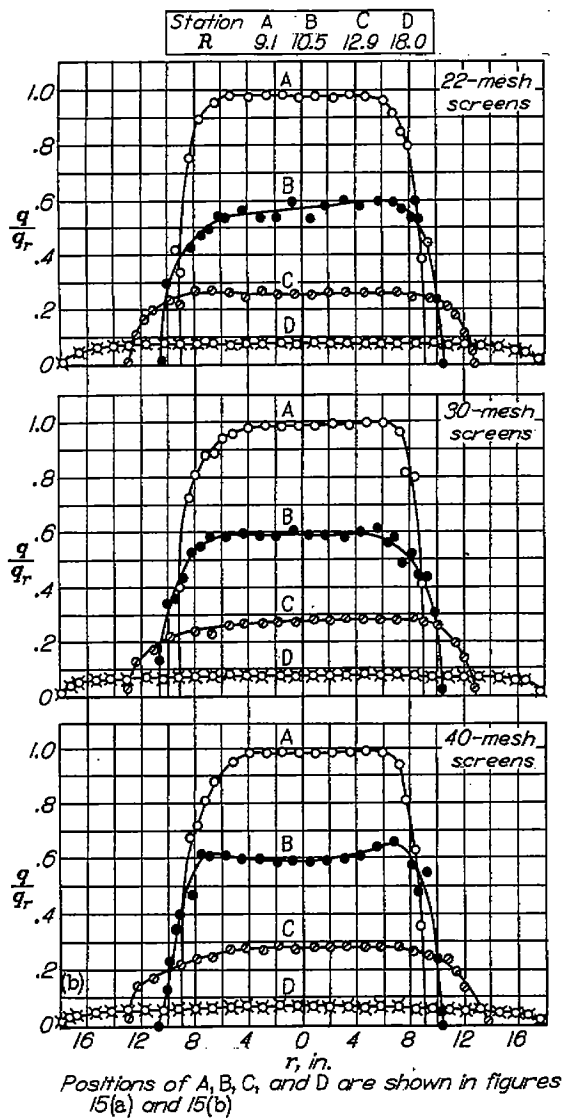

(b) Charts showing dynamic-pressure distributions at various diffuser sections and proportion of diffuser area filled by various proportions of total flow.

FIGURE 15.—Continued.



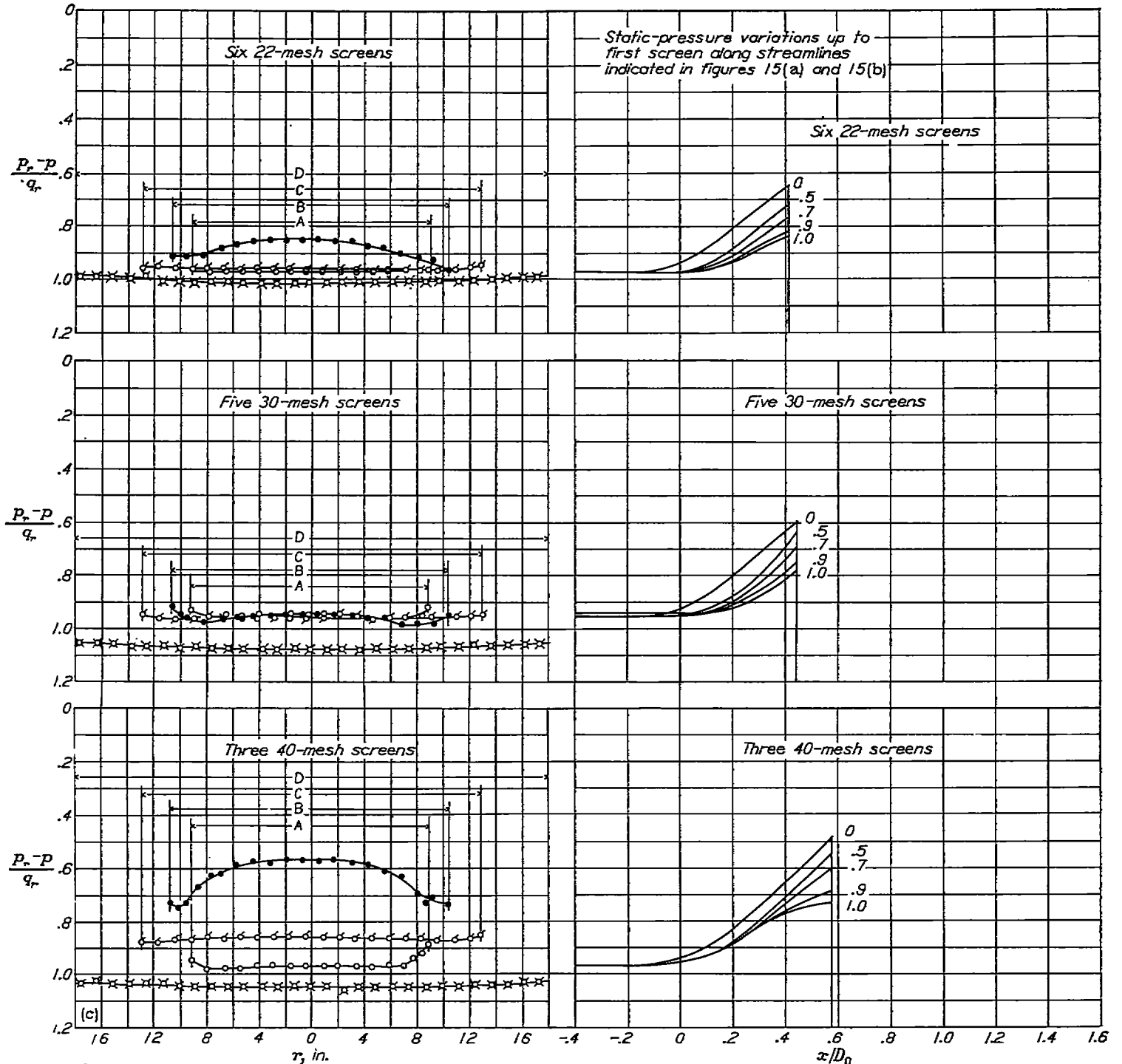

Positions of A, B, C, and D are shown in figures 15(a) and 15(b)

(c) Charts showing static-pressure distributions at various diffuser sections and along selected streamlines.

FIGURE 15.—Concluded.

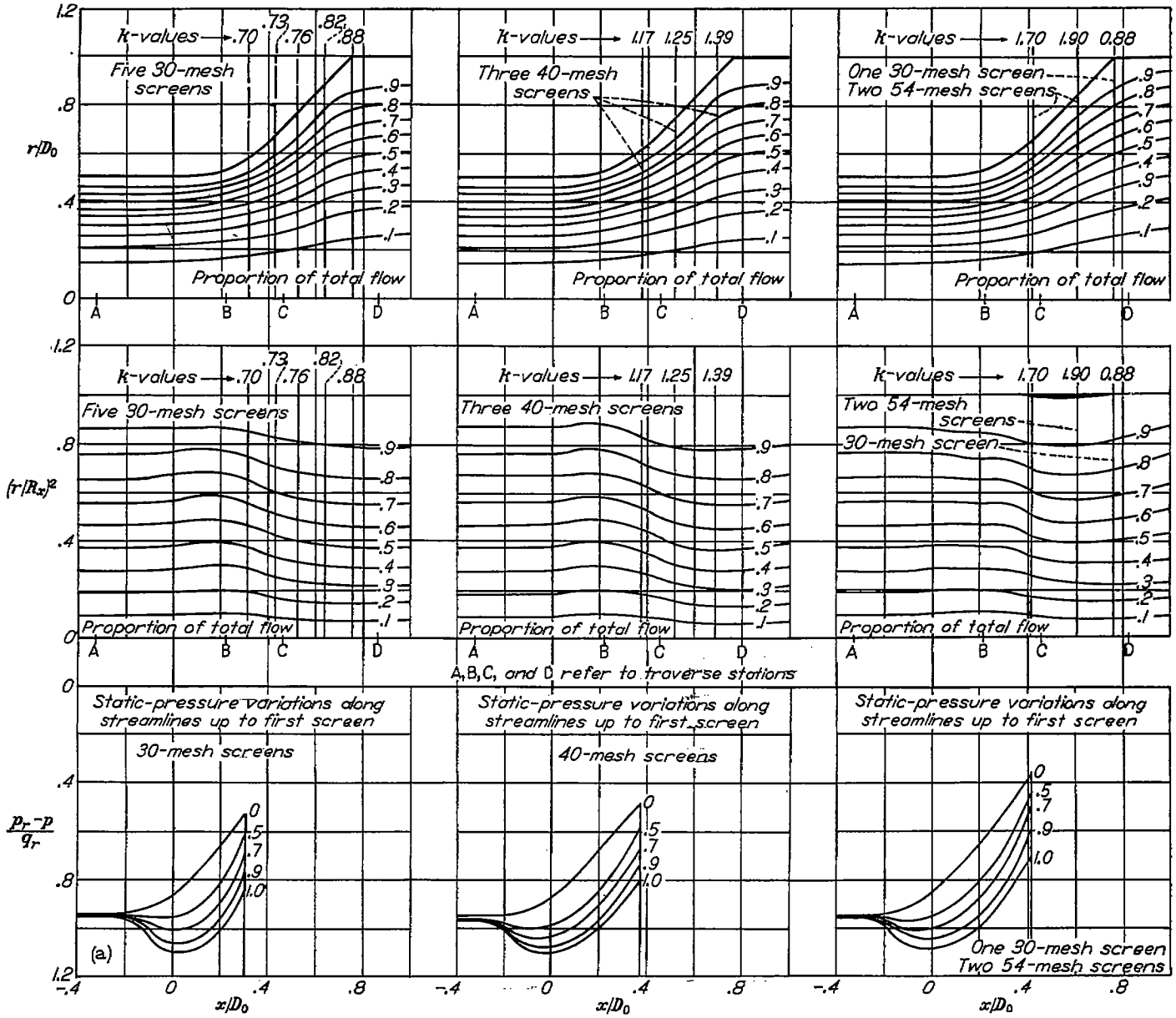

(a) Charts showing streamline patterns, proportion of diffuser area filled by various proportions of total flow, and static-pressure distributions along selected streamlines  
 FIGURE 10.—Results of tests of diffuser B with various multiple-screen combinations

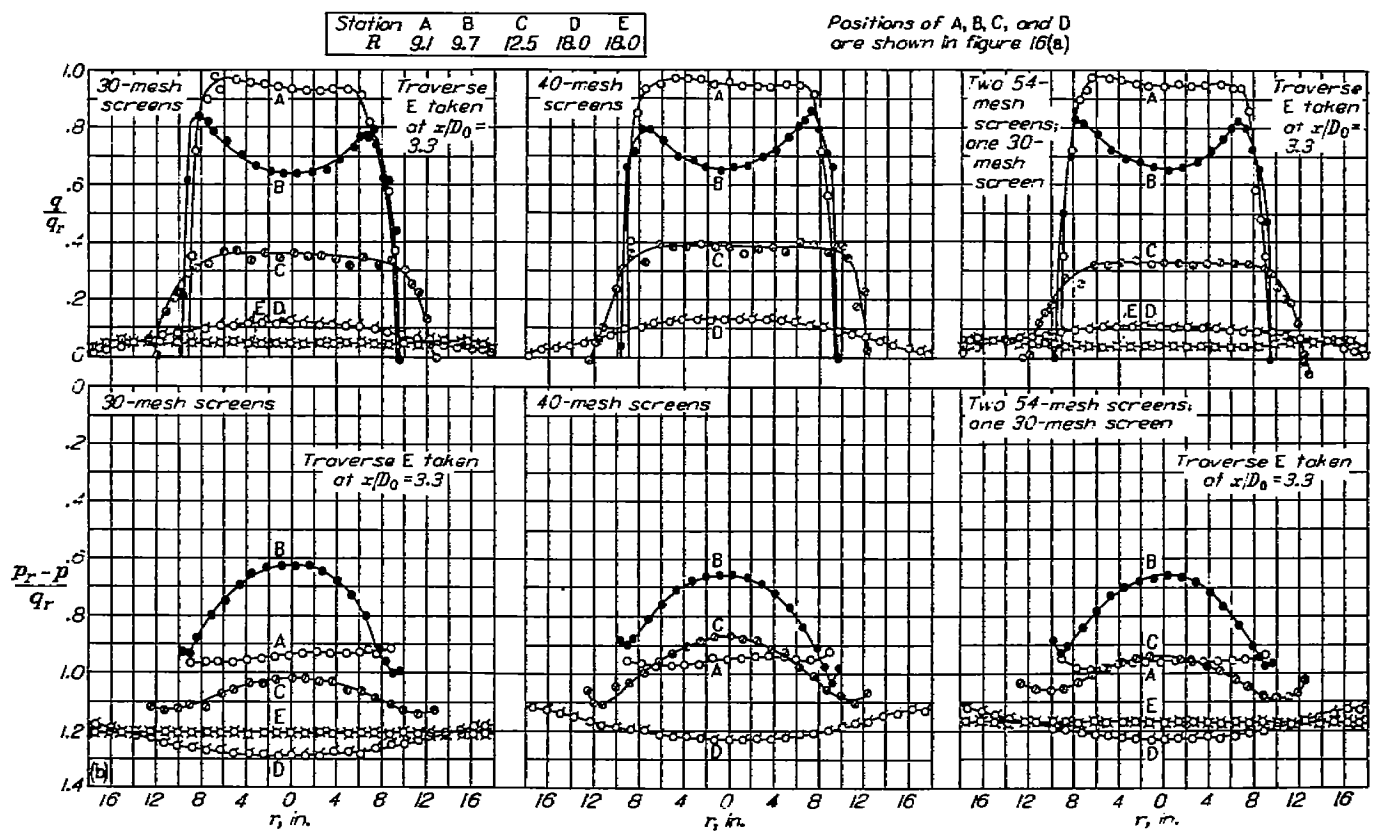
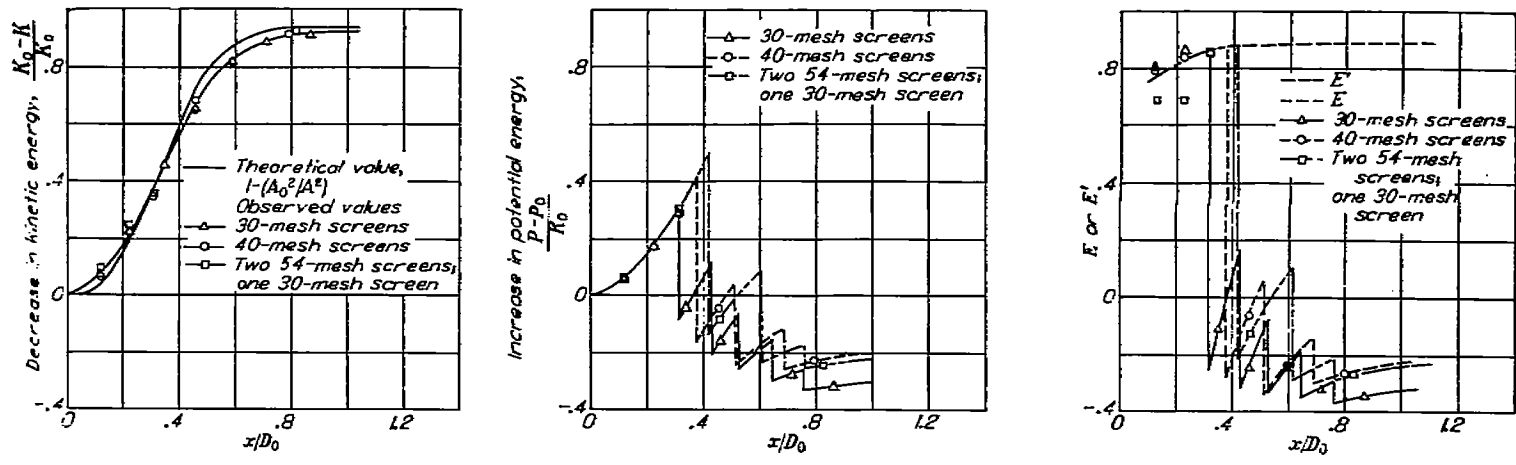

(b) Charts showing changes in kinetic and potential energies, efficiencies, and dynamic- and static-pressure distributions at various diffuser sections.

FIGURE 16.—Concluded.

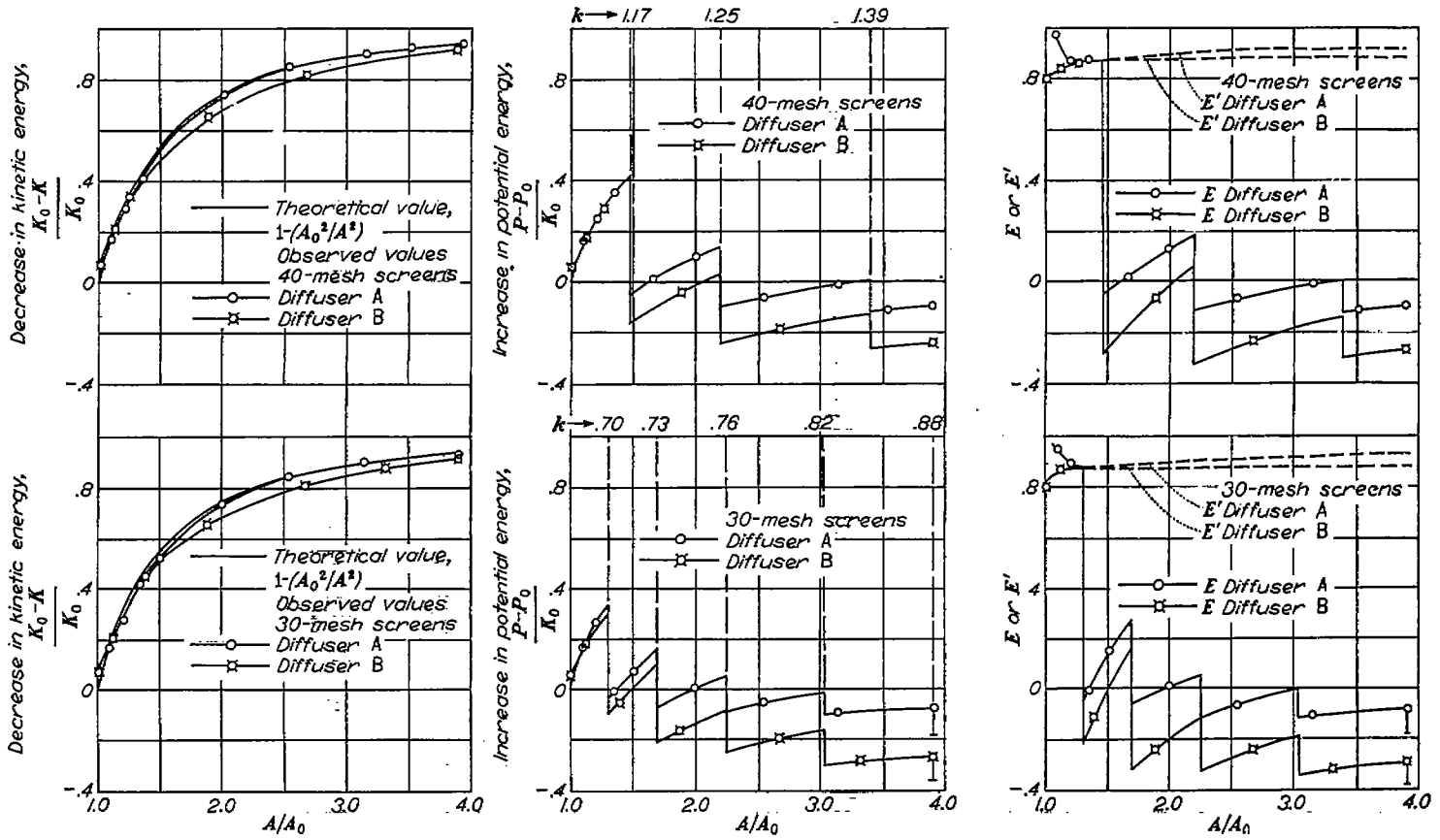
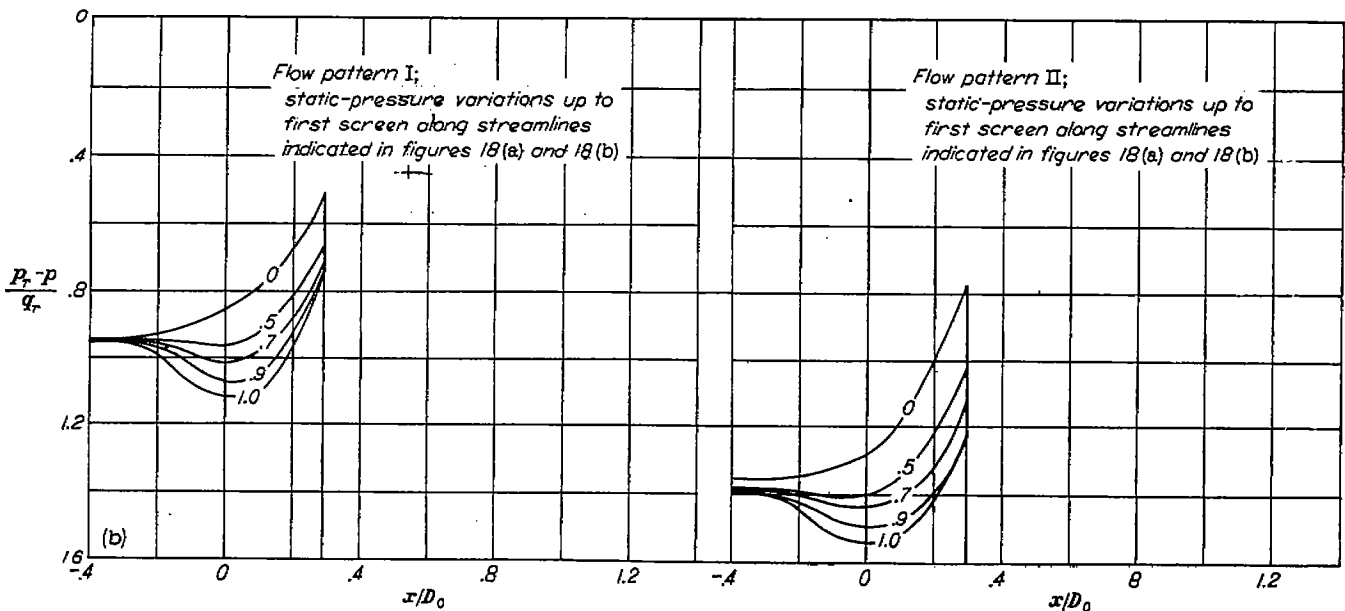
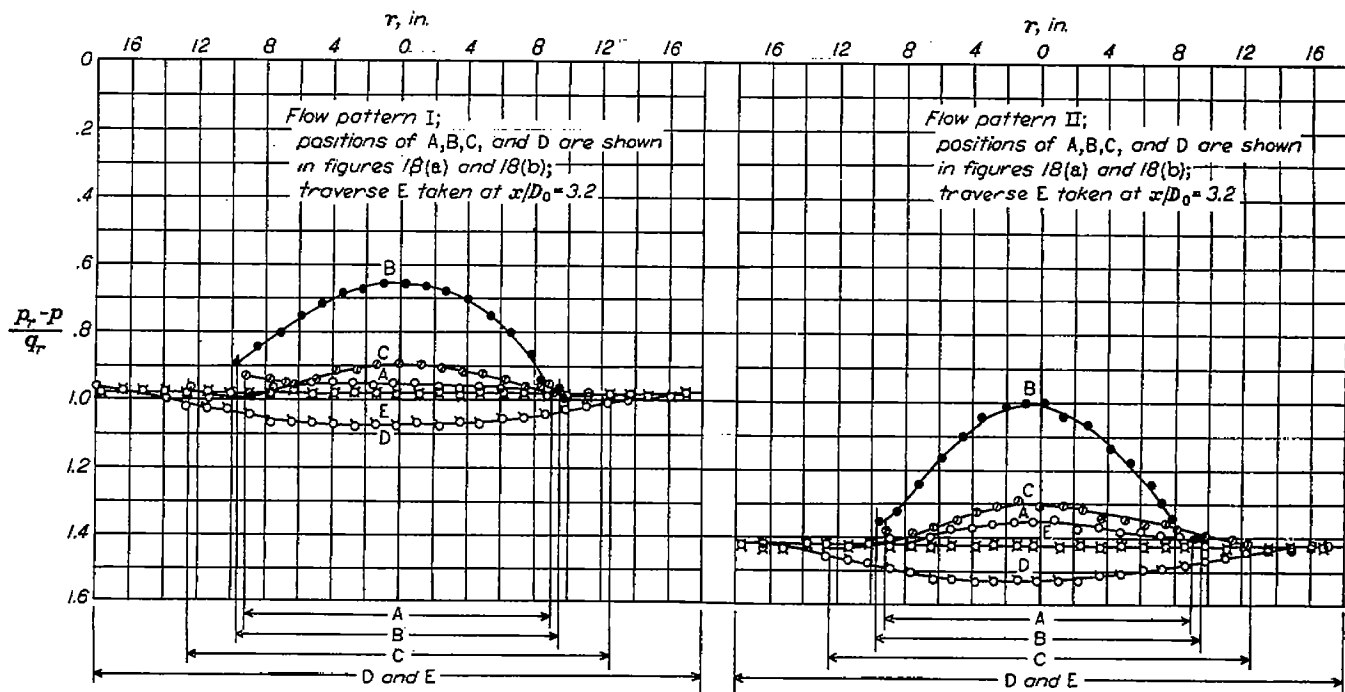
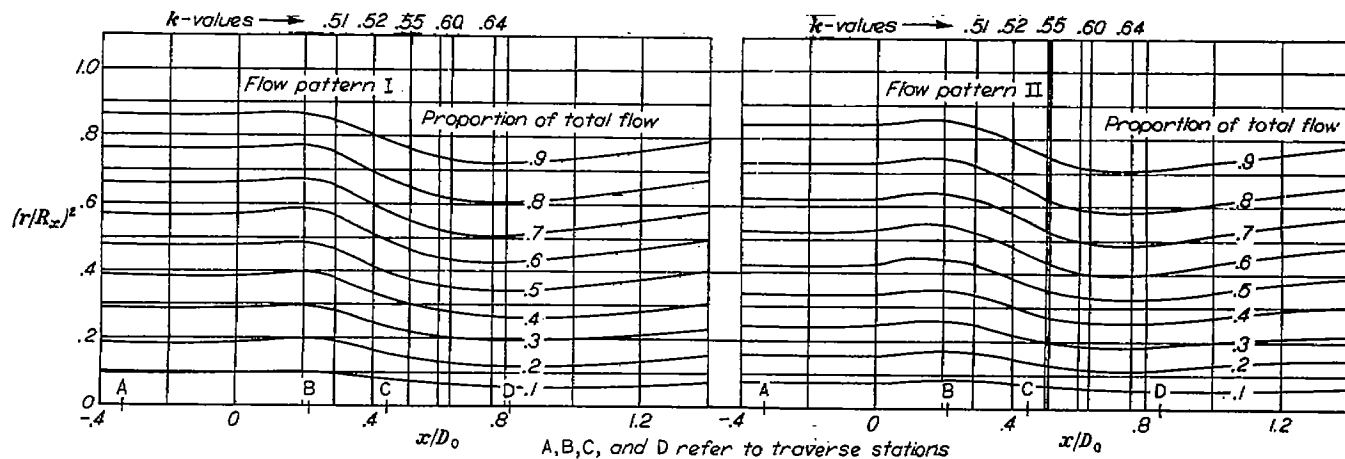

FIGURE 17.—Comparison of test results of diffusers A and B with the 30- and 40-mesh multiple-screen combinations shown in figures 15 and 16. Charts showing changes in kinetic and potential energies and efficiencies.





(b) Charts showing proportion of diffuser area filled by various proportions of total flow, static-pressure distributions at various diffuser sections, and static-pressure distributions along selected streamlines.



Figure 18 shows the results of a test in diffuser B to find the effect of initial velocity distribution. The curves of  $q/q_r$ , labeled "A" in figure 18 (a) show the usual distribution in the left-hand diagram, called "flow pattern I," and a simulated fully developed turbulent pipe-flow distribution in the right-hand diagram, called "flow pattern II." For this test an attempt was made to compensate for the abnormally high pressure drop through screens by shifting all screens downstream and using one less screen than would have been used by following the relations of equation (9). It can be seen in figures 18 (a) and 18 (b) that transition from pattern I to pattern II resulted in slightly lower final efficiency, a little less uniformity in the final distribution of  $q/q_r$ , and slightly poorer filling. However, the over-all effect was small.

The effect of transition to a very thin initial boundary layer was tested in diffuser A with all the multiple-screen combinations. For this experiment a large section of the entrance duct was omitted and the entrance nozzle was connected with only 3 feet of duct to the diffuser. In these cases no effect could be found. It may be concluded that when as many screens are used as in the present experiments with multiple screens, the initial velocity distribution has no substantial effect on performance.

It may be considered that in a flow system with no pressure rise there should be no flow separation. Any diffuser, regardless of the width of the angle, approaches such a system when screens are positioned by the relations of equation (9), and the number of screens increases without limit. This serves to emphasize the importance of number of screens and of the minor role played by initial velocity distribution and diffuser shape and angle when the number of screens is large.

Diffuser B was selected as an extreme case, and it was not expected at the outset that the results would compare as favorably with those of diffuser A as they actually did. On considering the question of the selection of a diffuser to be used with damping screens, it appears that about the only drawback to extreme angles is a reduction in efficiency from the abnormal pressure drop through screens. Some additional reduction in turbulence might be realized because of an apparently higher effective value of  $k$ , but it still remains to be shown that this would actually be the case.

As pointed out in reference 5, seams in screens produce turbulent wakes in which the turbulence is much above the general level. Other irregularities such as patches or dirt may have similar effects. With a diffuser such effects may be magnified because wakes may grow rather than diminish because of the adverse pressure gradient. There was some evidence of this obtained in diffuser A, where in one of the tests the wake of a small patch on the second screen could be detected in the velocity distribution after having passed through the remaining four screens. Although the evidence on this point is meager, it is well to be aware of the possibility that seams, patches, or large particles of dirt may produce some unwanted results.

## CONCLUSIONS

The following conclusions may be drawn from the results of a low-speed experimental investigation of the filling effect observed when a screen or similar resistance is placed across a diffuser:

1. There is a spreading effect on a stream that flows through a screen when the stream is unbounded or is bounded by a region of low velocity. The spreading action depends on the initial velocity distribution, on conditions at the stream boundaries, and on the pressure-drop coefficient of the screen.

2. A screen can prevent separation or restore separated flow in a diffuser. The mechanics of the process is intimately connected with the mechanics of turbulent boundary-layer separation. The screen may prevent separation either by increasing the normal velocity gradient near the diffuser wall, by decreasing the pressure gradient along the wall, or by a combination of these two effects.

3. Separation may be prevented and a filled condition obtained throughout a properly shaped diffuser by a single screen or throughout a diffuser of arbitrary shape by using a sufficient number of appropriate screens properly spaced.

4. A filled condition and uniform velocity distribution may be attained downstream from a single screen in a diffuser of arbitrary shape even in the presence of separated flow upstream from the screen. Such screens have a stabilizing effect on the flow so that speed fluctuations normally resulting from such separation are greatly diminished.

5. Annular space around the screen near the diffuser walls had little beneficial effect upon the diffusion process. Such a space may actually be detrimental by destroying the symmetry of flow.

6. For the same energy loss, a filled condition upstream from a screen is maintained better with a screen of low pressure-drop coefficient near the natural separation point than with a screen of higher coefficient downstream from that point.

7. Diffuser efficiency generally is low when the prevention of separation depends on the action of one or more screens. The principal losses are due to the pressure drop through screens. Rough estimates of efficiency may be made in any given case.

8. The use of wide-angle diffusers in wind tunnels in combination with damping screens is shown to be one application to which diffuser-screen combinations are well suited. When screens are properly distributed through the diffuser there is no danger of separation and the flow has a high degree of uniformity. The performance is not critical to the diffuser shape or to the initial velocity distribution. When the total included angle of a diffuser is not greater than about  $30^\circ$ , there is only a negligible pressure drop across three screens having an average value  $k=1.25$ , five screens having an average value  $k=0.76$ , and six screens having an average

value  $k=0.57$ , where  $k$  is the pressure-drop coefficient. For these cases the turbulence reduction factor should be about the same as the area ratio of the wide-angle diffuser.

NATIONAL BUREAU OF STANDARDS  
WASHINGTON, D. C., *June 25, 1947*

REFERENCES

1. McLellan, Charles H., and Nichols, Mark R.: An Investigation of Diffuser-Resistance Combinations in Duct Systems. NACA ARR, Feb. 1942.

2. Squire, H. B., and Hogg, H.: Diffuser-Resistance Combinations in Relation to Wind Tunnel Design. Rep. No. Acro 1933, British R. A. E., 1944.
3. Eckert, B., and Pfüger, F.: The Resistance Coefficient of Commercial Round Wire Grids. NACA TM 1003, 1942.
4. Patterson, G. N.: Modern Diffuser Design. Aircraft Engineering, vol. X, no. 115, Sept. 1938, pp. 267-273.
5. Dryden, Hugh L., and Schubauer, G. B.: The Use of Damping Screens for the Reduction of Wind-Tunnel Turbulence. Jour. Aero. Sci., vol. 14, no. 4, April 1947, pp. 221-228.