

NATIONAL ADVISORY COMMITTEE FOR AERONAUTICS

TECHNICAL NOTE

No. 1031

A MULTIPLE BRIDGE FOR ELIMINATION OF CONTACT-RESISTANCE

ERRORS IN RESISTANCE STRAIN-GAGE MEASUREMENTS

By Isidoro Warshawsky.

Aircraft Engine Research Laboratory
Cleveland, Ohio



Washington
March 1946

NACA LIBRARY
LANGLEY MEMORIAL AERONAUTICAL
LABORATORY
Langley Field, Va.

NATIONAL ADVISORY COMMITTEE FOR AERONAUTICS

TECHNICAL NOTE NO. 1031

A MULTIPLE BRIDGE FOR ELIMINATION OF CONTACT-RESISTANCE
ERRORS IN RESISTANCE STRAIN-GAGE MEASUREMENTS

By Isidore Warshawsky

SUMMARY

A multiple-bridge circuit is described that eliminates contact-resistance errors of the first order between the arms of the ordinary Wheatstone bridge. This circuit is applied to the elimination of the effects of contact-resistance variations that may occur in resistance strain-gage measurements made through switch contacts or slip rings. No additional wiring is required at the strain gages, and the number of slip rings need not necessarily be increased. The general theory is derived and correct circuits and constructions are described. The methods allow considerable freedom in choice of circuit combinations and are applicable to multiple-point strain measurements, particularly on rotating shafts or propeller blades. Other applications of the multiple-bridge circuit are noted.

INTRODUCTION

In measuring structural strains by observing the change in electrical resistance of a wire or a carbon strip attached to the surface of the test member, it is necessary to detect accurately a resistance change of a fraction of 1 percent. The fractional change in resistance of an Advance wire strain gage that is in common use is approximately twice the numerical value of the elastic strain (reference 1); for example, a stress of 10,000 pounds per square inch in aluminum involves a resistance change of 0.2 percent. In order to achieve an accuracy of 2 percent in such a measurement, the resistance must be measured to an accuracy of 0.004 percent.

Although resistance changes of such small magnitudes may be measured quite readily by ordinary bridge methods in those cases where direct connection to the strain gage can be made through well-soldered connections, the problem becomes difficult when connection to the strain gage must be made through switch contacts or slip rings.

Examples are the measurement of stresses at a number of locations by the use of a single bridge and a multiple-position selector switch and certain cases of multiple-point stress measurements on a rotating shaft or propeller blade.

In such cases, the possible variation in contact resistance between switch contacts or between brush and slip ring may be of the same order of magnitude as the resistance change due to actual strain variation and, if this contact resistance lies in series with the strain gage itself, large errors are introduced into the measurements. To remedy this situation, several expedients are generally employed: (1) circuits so constructed that the contact resistance no longer lies in series with the strain gage but occurs instead at a point in the circuit where it has negligible effect; (2) the use of strain gages of very high resistance; and (3) the use of very heavy switch contacts or of a number of parallel-connected brushes. Each of these methods sometimes possesses certain limitations: the first often requires an excessively large number of resistors when applied to multiple-point measurements; the second sacrifices electrical stability; and the third is mechanically complicated.

This report describes a new circuit which renders negligible the effects of contact resistance occurring at the corners of a conventional Wheatstone bridge and the particular application of this circuit to measurements with resistance strain gages. In order to illustrate the problem of contact resistance more clearly and to define the scope of the new circuit and its relation to existing techniques, a brief review of representative methods of measurement that are in common use will first be made.

CIRCUITS ORDINARILY USED FOR STRAIN MEASUREMENT

Series Circuit for Measurement of Alternating Strains

Strain variations due to flexural or torsional vibrations are often measured by the series circuit shown in figure 1(a), in which the indicator is a rectifier-type moving-coil galvanometer for rms measurements or an oscillograph preceded by a vacuum-tube amplifier for instantaneous indication. The strain-gage leads are soldered to two slip rings and the brushes bearing on these slip rings are wired to the remainder of the circuit. The alternating voltage appearing across the strain gage R or across the fixed resistor S is proportional to the alternating strain. To approach maximum sensitivity for a given power dissipation in the strain-gage, the resistance of S must be several times that of R .

This circuit is equivalent to that of figure 1(b), the contact resistance between brushes and slip rings being represented by r . Any variation in the magnitude of r appears as an apparent strain whose maximum value, for an Advance wire strain gage, is equal to the fractional change in strain-gage resistance. This result is obvious because a change $+\Delta r$ in the contact resistance in each arm has the same effect as would a change $\Delta R = 2\Delta r$ in strain-gage resistance, and the corresponding strain ϵ is approximately

$$\epsilon = \frac{1}{2} \frac{\Delta R}{R} = \frac{\Delta r}{R}$$

This is the maximum possible error; the most probable error resulting from a contact-resistance variation $\pm\Delta r$ in each arm is one-half of the maximum possible error.

Bridge Circuit for Measurement of Strains

A Wheatstone bridge such as that shown in figure 2(a) is often used to measure strains at a large number of points and utilizes a single bridge and a two-pole multiple-position selector switch. This circuit is equivalent to that of figure 2(b), wherein the contact resistance has been represented by r . As in the case of the series circuit, any variation in this contact resistance appears as an apparent strain equal to the fractional change in resistance of this arm of the bridge.

For measurement of the alternating component of strain, the power source and indicator are the same as those described for the series circuit of the preceding section. For measurement of steady strains, the power source is a battery, an alternating-current generator, or an audio-oscillator; the generator or oscillator is used to eliminate the effects of thermoelectric potentials at the switch contacts or when a carrier system is desired in order to facilitate amplification.

An alternative circuit to that of figure 2(a) is shown in figure 2(c), in which the two-pole switch is replaced by a single-pole switch and one side of each strain gage is soldered to a common terminal. This method has the advantage of tolerating twice as large a value of $\Delta r/R$ as does the circuit of figure 2(a).

Steady-strain measurement is made by observing the deflection of the indicator or by rebalancing the bridge by one of several methods, some of which are shown in figures 3(a) to 3(d). In figure 3(a), balance is restored by using, in arm S, a dummy strain.

gage clamped to a calibrated cantilever beam deflected by a micrometer screw graduated directly in strain units. In figure 3(b), arm S is shunted by a calibrated high-resistance rheostat until bridge balance is restored. In figure 3(c), the ratio arms are altered to restore balance; in figure 3(d), the power connection to the bridge is moved. In the circuits of figures 3(b) to 3(d), resistance at the sliding contact of the rheostat-potentiometer does not materially affect the accuracy of the measurements unless a detector of very low resistance is used in a deflection method.

A Wheatstone bridge circuit similar to that of figure 2(a) with the switch replaced by slip rings and brushes to permit strain measurement on a rotating member is theoretically possible, but is not used because of the high brush contact resistances that are present.

In order to make the circuits of figures 1 and 2 useable, it is necessary that the change Δr in contact resistance be very small compared to the strain-gage resistance R . For example, if an accuracy of 2 percent is required in measuring a stress of 10,000 pounds per square inch in aluminum, the ratio $\Delta r/R$ must be less than 0.0004. In measurements through slip rings, the usual methods for achieving so low a ratio are first, to minimize Δr by using a large number of brushes connected in parallel and bearing on the same slip ring and second, to increase R by using high-resistance strain gages made of carbon rather than the more stable and adaptable wire strain gages, which are of comparatively low resistance. Thus, the use of a 30,000-ohm carbon strain gage with a gage factor of 10 would allow Δr to be as high as 6 ohms in the above example, whereas the use of a 1000-ohm Advance wire strain gage with a gage factor of 2 would require Δr to be not over 0.04 ohm. When multiple-point strain measurements are to be made, a possible solution of the switch-contact-resistance problem is the use of a high-quality heavy-duty selector switch having low and constant contact resistance. Switches are available with so low a resistance that the use of low-resistance wire strain gages is possible, provided that high sensitivity is not required.

Currently Used Strain-Measuring Circuits Free from

Contact-Resistance Errors

Effective elimination of contact-resistance errors can be accomplished by using a separate reference resistor with each strain gage or a separate bridge with each strain gage, as shown in figures 4 and 5. The circuits of figures 4 and 5 may use either a

direct-current or an alternating-current power supply. Circuits of this type are used frequently in present-day practice.

The circuit of figure 4 is used for multiple-point measurements. This circuit uses a separate compensating resistor for each strain gage and has two common connections, requiring only a single-pole switch in the meter circuit; the switch-contact-resistance variation in this circuit must be a negligible fraction of the meter resistance if a deflection method is used. It is also essential that there be negligible variation in the resistance of the common leads and of the power supply. If a null method of measurement is employed, the variation in resistance between points 1 and 5 and between points 4 and 6 must be negligible compared to the parallel resistance between points 5 and 6. Also, the resistance of leads 1-5 and 4-6 must be approximately in the same proportion as the two ratio arms of the bridge. If a deflection method is used, an additional condition is imposed: any variation in the resistance of the power supply and its leads must be negligible compared to the parallel resistance between points 5 and 6. In the deflection method, for example, the use of twenty 100-ohm strain gages in an equal-arm bridge arrangement would require that the variation in the resistance of the circuit through points 5-1-2-3-4-6, which includes the power supply, should be less than 0.1 ohm in order to attain 1-percent accuracy.

The circuit of figure 5 is used for strain measurements on rotating members. The contact resistances between brushes and slip rings are in series with the power supply and the detector and can be made of negligible proportions with little difficulty.

Multiple-point strain measurements on a rotating member using a selector switch can be made by a combination of the circuits of figures 4 and 5. Referring to figure 4, slip rings must be inserted in the battery circuit between points 1 and 2 and between points 3 and 4; another slip ring must be inserted between the detector and the junction of the ratio arms A and B; finally, a fourth slip ring is inserted between the detector and the single-pole selector switch if this switch is mounted on the rotating member. If the switch cannot be mounted on the rotating member, individual slip rings are used to connect each junction between a strain gage and its compensating resistor to its respective switch point.

CIRCUITS FOR ELIMINATION OF CONTACT-RESISTANCE ERRORS

A new method for the virtual elimination of errors caused by contact-resistance variations at switch contacts or slip rings utilizes the properties of the multiple-bridge circuit analyzed

mathematically in the appendix. The most general circuit of this type is built up in the steps shown in figure 6. Construction begins with the simple Wheatstone bridge circuit of figure 6(a), wherein a contact resistance r is assumed to occur at the four corners of the bridge. Each of these original contact resistances is then bridged by a pair of auxiliary arms a, b ; c, d ; f, g ; and h, k whose ratio to each other is equal to the ratio between the adjacent main arms (fig. 6(b)). Connection between the auxiliary arms and the main arms is made through a separate brush or switch contact, whose resistance is denoted by r , and the power lead or the detector load that originally went to the corner of the simple bridge is connected instead to the junction of the two auxiliary arms. It is shown in the appendix that this construction has the effect of canceling first-order effects of the contact resistance occurring at any corner of the original bridge because this resistance is, in effect, divided between the two adjacent main arms in the same proportion as the ratio of these main arms.

In the practical application of the multiple-bridge circuit to resistance strain-gage measurements, the use of separate contacts for connecting the strain gage to the main bridge arms and to the auxiliary ratio arms does not mean that more than two wires need be led off from each gage; the application requires only that two connections, instead of one, be made at the slip ring or the switch at which the contact resistance occurs. Furthermore, all four pairs of auxiliary ratio arms are rarely needed; most applications utilize no more than two pairs. These conditions are illustrated by the following representative circuits.

Strain Measurement through Slip Rings

The circuit of figure 7(a) (equivalent circuit shown in fig. 7(b)) is used where only the one strain gage R is carried on the rotating member. A single pair of slip rings is used, just as in a conventional circuit, but each ring has two brushes. One brush on each ring lies in the main bridge circuit composed of R , S , A , and B . The other brush on each slip ring is in series with the auxiliary ratio-arm resistors b and d . The auxiliary ratio arms a, b and c, d act as potential dividers across the contact resistance occurring in the main bridge circuit. The values of these resistors must be such that $A/B = a/b$ and $A/S = c/d$. Very good compensation is obtained if the auxiliary resistors are 1000 times the probable contact resistance.

The divider a, b at the lowest corner of the bridge will be recognized as that of the usual Kelvin double bridge. The divider c, d at the right-hand corner is an additional compensating network

that is not found in the usual Kelvin bridge because the Kelvin bridge is ordinarily used for measurements wherein contact resistance in series with the main ratio arms produces negligible errors. On the other hand, resistance-strain-gage measurements that must detect resistance changes of a few thousandths of 1 percent would be in serious error if contact-resistance variations of the same magnitude occurred in the main ratio arms.

The error that results, expressed as the apparent fractional change in resistance of the strain gage, is of the order of magnitude of the square of the ratio of the contact resistance to the bridge-arm resistance, rather than the first power of this ratio as it would be in a similar bridge circuit without auxiliary ratio arms. Specifically, assuming the same contact resistance at each of the brushes, this second-order error is the sum of two terms, one term being proportional to the square of the contact resistance and the other term varying as the product of the contact resistance by the amount of bridge unbalance. (See equation (43) of appendix.) The error is thus least when the bridge is balanced and increased as the bridge becomes unbalanced by the increase in strain. Table 1 lists some desirable combinations of resistance values for the various arms of bridges using strain gages having resistances of 100, 500, and 1000 ohms. For each of these bridges, table 2 lists the maximum errors in indicated strain, which would be caused in an initially balanced bridge by the introduction of 1 ohm of contact resistance at each brush and also the error in indicated strain in a bridge that is 1 percent out of balance, under the same conditions that lead to maximum error in the balanced bridge. For purposes of comparison, there are also listed the maximum errors that would be caused by the introduction of 1 ohm of contact-resistance variation occurring in the Wheatstone bridge circuit of figure 2(a). It will be noted that the ratio between errors in the two types of bridge, which might be termed the "factor of advantage," is between 110 and 4000. This factor of advantage would be still greater if the assumed contact resistance were 0.1 ohm rather than 1 ohm. The factor of advantage would be half as great if the two brushes shown in figure 7(a) on each slip ring were merely connected in parallel in a simple Wheatstone bridge arrangement. In these computations of errors, it has been assumed that errors occurring at each brush do not compensate each other, but are such as to produce the greatest possible error in an initially balanced bridge.

The distinction between the terms "contact resistance" and "contact-resistance variation" is to be noted. In the Wheatstone bridge circuit of figure 2(a), any constant contact resistance may be balanced out in the initial balancing of the bridge and only the subsequent variations in this contact resistance are material, the error being proportional solely to these variations. In the multiple bridge, errors due solely to the constant contact resistance may also be balanced out, but the additional errors introduced by

subsequent variations in the contact resistances are proportional not only to these variations but also to the contact resistances themselves. This condition is a consequence of the fact that errors in the multiple bridge are of the second order, whereas errors in the simple Wheatstone bridge are of the first order. In order to simplify computations for the data of table 2 and subsequent tables, both the contact resistance and the contact-resistance variations have been assigned the value of 1 ohm.

For null measurements, the bridge of figure 7(a) may be balanced by any of the methods shown in figure 3: by using a dummy gage or a calibrated cantilever in arm S (fig. 3(a)), by shunting arm S (fig. 3(b)), by changing the main ratio arms (fig. 3(c)), or by changing the position of the battery connection (fig. 3(d)).

The circuit of figure 7(c) (equivalent circuit shown in figure 7(d)) may be used when an additional slip ring can be installed and when an additional resistor can be mounted on the rotating member. This resistor may be a fixed one, may be a compensating strain gage used to balance out any temperature effects, or may be another strain gage used in order to provide direct indication of the difference between strains at two locations. The bridge may be balanced by varying the main ratio arms, as in figure 3(c). The values of the auxiliary ratio arms c, d, f, g must be such that $A/S = c/d = f/g$.

An advantage of this circuit over that of figure 7(a) is the fact that it allows for the use of a compensating strain gage near the indicating strain gage to reduce the effects of drift due to temperature and time, which so seriously limit the usefulness of these instruments in steady-strain measurements.

Some desirable combinations of circuit constants for the arrangement of figure 7(c) are listed in table 3. The errors in strain measurement produced by a contact resistance of 1 ohm at each brush on the two outside slip rings are given in table 4. (The errors caused by contact resistance in the meter circuit are neglected; these errors are zero if a null method is used.) Comparisons with a similar circuit having the same values of R, S, A, and B, but without auxiliary arms, are made, as was done for the circuit of figure 7(a). The factors of advantage vary from 230 to 4000. If a deflection method is used, the contact-resistance variation at the meter switch contact must be a negligible fraction of the meter resistance; for example, for 1 percent accuracy, the contact-resistance variation must be less than 1 percent of the meter resistance.

Circuits for Multiple-Point Strain Measurement

Multiple-point strain measurements, using selector switches, are distinguished from those involving slip rings by the fact that in many cases one side of each strain gage may be connected in common through a soldered connection, thereby eliminating a source of error and simplifying the circuit. Typical circuit arrangements are shown in figure 8.

The circuit of figure 8(a) uses the same standard resistor S for all strain gages and breaks both sides of the strain-gage circuit. Its equivalent circuit is identical with figure 7(b) and the data of tables 1 and 2 apply. This circuit may be balanced by any of the methods shown in figure 3.

The standard Kelvin bridge circuit of figure 8(b) has one side of all strain gages common and is a simplification of figure 8(a); the number of switch banks is halved and one pair of auxiliary ratio arms is eliminated. Representative combinations of bridge constants are presented in table 5. Data indicating the advantages of this circuit over the comparable bridge circuit of figure 2(c) are presented in table 6.

The circuit of figure 8(c) uses a separate compensating resistor for each strain gage, breaks both sides of the circuit, and requires a five-pole switch. Its equivalent circuit is identical with that of figure 7(d) and the data of tables 3 and 4 apply. For deflection measurements, the contact-resistance variation at the meter switch contact must be a negligible fraction of the meter resistance. For null measurements, balance may be obtained by the method of figure 3(c). Simplifications of this circuit are possible, if one side of the resistors can be connected in common.

The circuit of figure 8(d) permits a separate compensating resistor to be used for a group of strain gages and allows for switching different groups, each with its own compensating resistor. One side of each strain gage is common and one side of each compensating resistor is common. Only one pair of auxiliary ratio arms is necessary. Other variations of the circuit of figure 8(c) can accomplish the same result; all variations require a five-pole switch if there are no common connections and a four-pole switch if common connections are permitted. Balance may be obtained by the method of figure 3(c).

Multiple-Point Strain Measurements Through Slip Rings

The arrangements described above may be combined to allow measurements on a number of strain gages attached to a rotating member, using only a few slip rings. Representative arrangements are shown in figure 9 wherein three or four slip rings are used to make measurements on any number of gages, selection being made by a solenoid-operated, multiple-pole, multiple-position stepping switch that is mounted on the rotating member and moves with it. An additional pair of slip rings may be needed to bring power to the solenoid.

The circuit of figure 9(a) has one side of all gages common, uses a two-pole switch, and requires two slip rings with one brush on each and one slip ring with both primary and secondary brushes. It may be balanced by any of the methods of figure 3.

The circuits of figures 9(b) and 9(c) require three slip rings, two with main and auxiliary brushes. The reference resistors and the auxiliary ratio arms for the meter circuit are carried on the rotating member. Balance is obtained by the method of figure 3(c). The circuit of figure 9(b) uses the same compensating resistor for all strain gages and requires a two-pole switch, whereas the circuit of figure 9(c) uses a separate compensating resistor for each gage and requires a four-pole switch.

The circuit of figure 10 permits measurements on a rotating member carrying strain gages of two different nominal resistances. A solenoid-operated stepping switch on the rotating part is advanced synchronously with a similar switch at the measuring bridge. At the same time that the first switch advances to a strain gage of different nominal resistance, the second switch changes resistor S and also shunts the auxiliary ratio arm d to maintain the necessary proportions between arms. This circuit resembles that of figure 9(c), except that the reference resistors are no longer on the rotating member. Strain values are obtained from readings of the manually balanced slide wire K in a null method. A separate pair of slip rings may be needed to operate the stepping switch. Figure 10 shows the wiring diagram for a complete installation, including an additional nonshorting bank on the stepping switch at the bridge used to open the power-supply circuit when the switch advances and thus protect the detector.

Circuit for Use with High-Resistance Detector

The Kelvin bridge circuit shown in figure 11(a) may be used if the detector is a vacuum-tube voltage amplifier of high input

resistance. Dispensing with the auxiliary ratio arms at the right-hand corner of the bridge makes it necessary to have arms A and B of comparatively high resistance. If the fractional change in resistance due to strain is $\Delta R/R$, the contact-resistance variation is Δr , and the precision desired is p percent, the value of resistor B must be greater than

$$\frac{100}{p} \Delta r / (\Delta R/R)$$

The circuit may be balanced by the methods of figure 3 or by moving either of the left-hand potential taps, as shown in figure 11(b). This type of circuit is applicable also to multiple-point strain measurements. The high resistance of the main ratio arms makes this circuit very much inferior in sensitivity to the circuit of figure 7(a) when a moving-coil galvanometer is employed as a detector, but is no restriction when a vacuum-tube voltage amplifier is used.

Switching Circuits for Measurement of Sums and Differences of Strains

Direct measurement of the sums or differences of strains measured by resistance strain gages, in any desired combination, may be made by use of the multiple-bridge circuit and a multiple-pole, multiple-position selector switch, without introduction of any appreciable contact-resistance errors.

Two basic circuits of this type are shown in figure 12. In figure 12(a), the sum or difference of two strains is obtainable by use of a four-pole switch. In figure 12(b), the difference between any pair of strains out of a group of four is obtainable by use of a four-pole switch.

Circuits of this nature are directly applicable to the computation of principal strains from strain-rosette readings. In constructing such switching circuits, it will generally be found that the number of poles on the switch is approximately twice the number that would be required by a similar switching arrangement that did not contain auxiliary ratio arms or main and auxiliary terminals.

DISCUSSION

The circuits described for elimination of contact-resistance errors are intended merely to illustrate the techniques to be used and manifestly do not include every conceivable circuit that might

be employed. The majority of the circuits outlined require the application of one or both of two expedients: first, the use of auxiliary ratio arms and second, the use of separate "main" and "auxiliary" terminals. The result of these procedures is to make the errors approximately proportional to the square of the ratio of the contact resistance to the bridge-arm resistance instead of to the first power of this ratio, as would occur in a similar circuit without multiple-bridge features.

The effect of adding the auxiliary ratio arms can be described more exactly in the following manner: if, in a simple Wheatstone bridge, the error, expressed as the apparent fractional change in resistance of the variable arm, is of the order of magnitude of the ratio of contact resistance to bridge-arm resistance, then adding the auxiliary arms reduces this error by a factor of the order of magnitude of the ratio of contact resistance to auxiliary-arm resistance. As a result, the usual stringent limitations on contact resistance may be relaxed several hundredfold, the improvement in accuracy thus obtained being greater than the improvements obtained by the expedients of multiple brushes or of high-resistance carbon strain gages. The elimination of errors due to contact resistance is accomplished with little mechanical complication and only a moderate reduction in sensitivity of the measuring circuit.

The considerations that govern the conversion of a simple Wheatstone bridge circuit, such as that of figure 13, to a multiple-bridge circuit are derivable from the theory presented in the appendix. By standard electrical network transformations, the general circuit of figure 14(a) is replaceable by the equivalent circuit of figure 14(c). The effect is therefore one in which the contact resistance occurring at any corner of the bridge is divided between the two adjacent arms in the same proportion as the ratio of these arms, thus canceling first-order effects of the contact resistance. This effect follows from the fact that if

$$\frac{\Delta r_1}{\Delta r_2} = \frac{B}{R}$$

then

$$\frac{B + \Delta r_1}{R + \Delta r_2} = \frac{B}{R}$$

Inspection of figure 14(c) and comparison with figure 13 brings out the following points:

1. There is no appreciable change in the effective values of the four main arms; therefore there need be no change in the values of the resistors initially used to balance the bridge.

2. An appreciable resistance, due to the auxiliary ratio arms, is inserted in the battery circuit if arms c,d or f,g are used, so that a higher battery voltage is required in order to preserve the same voltage across the strain gage.

3. If arms a,b or h,k are used and a moving-coil galvanometer is the detector, an appreciable resistance is introduced into this circuit; therefore the galvanometer should be replaced by one that will match the new value of resistance which appears across its terminals. The new galvanometer will generally possess a higher coil resistance and also a higher current sensitivity. If a high-impedance vacuum-tube detector is used, no alteration is necessary and there will be no change in sensitivity.

The net loss in sensitivity caused by arms a,b or h,k will depend on the types of galvanometer available and cannot be expressed in any simple equation, but generally the reduction will be less than twofold. For example, for bridge 16 (table 5) if a commercial type of high-sensitivity spotlight galvanometer of 5-second period is used, the number of divisions of galvanometer deflection for a given $\Delta R/R$ and a given power dissipation in arm R will be half as great when the multiple bridge is used as when only the main bridge is used, assuming that in each case the galvanometer is so chosen that it will be critically damped by the circuit across its terminals. For any other bridge listed in this table, the reduction in sensitivity will be much less serious.

An important result of the points mentioned is that, when the presence of arms c,d or f,g would require a very large increase in supply voltage (as, for example, in bridge 8, table 3), it may be advantageous to interchange the positions of the power supply and the galvanometer. It should be noted, however, that whereas apparent loss in sensitivity caused by the presence of arms c,d or f,g may be offset by increasing the supply voltage until normal voltage appears across the strain gage, any loss in sensitivity caused by arms a,b or h,k cannot be compensated by increasing the battery voltage because doing so would also increase the voltage across the strain gage.

The precision of adjustment required for the auxiliary ratio arms is discussed in detail in the appendix. The following simple rule, however, holds approximately for an equal-arm bridge: the

precision of the auxiliary ratios must be $100 \frac{\Delta R}{R}$ percent, where ΔR is the permissible error in measurement of strain-gage resistance and r is the probable contact resistance.

It should be noted that the negligible contact-resistance error of the multiple bridge is derived from the fact that the ratio of contact resistance to bridge-arm resistance is generally so small a fraction that, when this fraction is squared, it becomes negligible. In most practical applications of the multiple bridge, a reasonable criterion for the existence of such a condition is that the contact resistance shall be less than 1 percent of the bridge-arm resistance. Most applications satisfy this criterion readily. On the other hand, if the contact resistance is very high, the multiple-bridge circuit loses its effectiveness. This statement applies even to a simple Kelvin double-bridge circuit such as that shown in figure 8(b); although this bridge would be unaffected by changes in the value of resistance occurring solely at the left-hand column of switch contacts, the addition of contact resistance in series with auxiliary arm *b* will disturb the balance of the bridge.

In determining the applicability of the multiple bridge and, in particular, in evaluating its merits with respect to other circuits for eliminating contact resistance, such as that shown in figures 4 and 5, it may be noted that the multiple bridge offers no advantage over the circuits of figures 4 and 5 insofar as reduction of contact-resistance errors is concerned. (In fact, if the contact resistance is occasionally very high, as in the case of poorly seated brushes, the multiple-bridge circuit will introduce more violent detector deflections than will either of the other two circuits mentioned.) On the other hand, the multiple-bridge circuit offers certain advantages in economy of the total number of resistors required for multiple-point measurements and in its versatility in permitting any desired combination of resistors or arrangement of the measuring circuit and considerable freedom in choice of balancing methods. Circuits such as those shown in figures 9, 10, and 12 illustrate these points.

The multiple bridge is generally applicable to measurements of exceedingly small resistance changes, as in the manganin-resistor pressure gage, and offers a possible improvement over the usual Kelvin bridge in measurements where appreciable contact resistance at the potential terminals is unavoidable. The circuit is applicable also to hot-wire anemometry, to measurements with four-wire resistance thermometers (permitting elimination of the usual reversing switch), and to situations where the strain gage or other

sensitive element is far from the measuring bridge circuit so that very long leads must be used. In the multiple bridge, these leads can be made to appear in the same portion of the circuit as do the contact resistances, so that considerable lead resistance can be tolerated and much smaller lead wire can be used than would be permissible in the conventional Wheatstone bridge circuit.

Aircraft Engine Research Laboratory,
National Advisory Committee for Aeronautics,
Cleveland, Ohio, February 8, 1946.

APPENDIX - THEORY OF THE MULTIPLE BRIDGE

The Wheatstone Bridge

Figure 13 represents the simple Wheatstone bridge, with the resistances and currents in the various arms as indicated. The equations for the network are:

$$i_H' - i_A' - i_S' = 0 \quad (1)$$

$$i_A' - i_B' + i_G' = 0 \quad (2)$$

$$i_S' - i_R' - i_G' = 0 \quad (3)$$

$$A'i_A' - S'i_S' - G'i_G' = 0 \quad (4)$$

$$B'i_B' - R'i_R' + G'i_G' = 0 \quad (5)$$

$$A'i_A' + B'i_B' + H'i_H' = E \quad (6)$$

The solution of these equations is

$$\left. \begin{aligned} i_A' &= EN_{A'}/D' \\ i_B' &= EN_{B'}/D' \\ \dots &\dots \dots \\ i_G' &= EN_{G'}/D' \end{aligned} \right\} \quad (7)$$

and so forth, where

$$\checkmark D' = A'B'S'R' \left(\frac{1}{A'} + \frac{1}{B'} + \frac{1}{S'} + \frac{1}{R'} \right) + G'(A' + B')(S' + R') + H'(A' + S')(B' + R') + G'H'(A' + B' + S' + R') \quad (8)$$

$$N_H' = (A' + S')(B' + R') + G'(A' + B' + S' + R') \quad (9)$$

$$N_{A'} = S'(B' + R') + G'(S' + R') \quad (10)$$

$$N_{B'} = R'(A' + S') + G'(S' + R') \quad (11)$$

$$N_{S'} = A'(B' + R') + G'(A' + B') \quad (12)$$

$$N_{R'} = B'(A' + S') + G'(A' + B') \quad (13)$$

$$\checkmark N_{G'} = A'R' - B'S' \quad (14)$$

The bridge is balanced when $N_{G'}$, the numerator of the equation for current in the detector arm G' , is zero:

$$A'R' - B'S' = 0 \quad (15)$$

Starting from an initially balanced bridge, the current in arm G' caused by a comparatively small change $\Delta R'$ in arm R' is, essentially,

$$i_{G'} = E \left(\frac{A'R'}{D'} \right) \left(\frac{\Delta R'}{R'} \right) \quad (16)$$

because the value of the denominator D' remains practically unchanged inasmuch as it is the sum of positive terms consisting of triple products of the resistances in the various arms, compared to which the change in D' due to $\Delta R'$, is negligible.

The Multiple Bridge

In the multiple-bridge circuit of figure 14(a), the main arms are A, B, S, R; the detector is G; the auxiliary ratio arms are a,b; c,d; f,g; h,k and the contact resistances that are bridged by the auxiliary ratio arms are r_{ab} , r_{cd} , r_{fg} , r_{hk} . Simpler circuits may be derived from this general arrangement by setting some of the variables equal to zero, as in the circuits of figure 15.

The currents in this network may be obtained by direct application of Kirchoff's laws and solution by simultaneous equations. An alternate method of solution, which is considerably simpler mathematically, utilizes the fact that the minor triangle including a,b, r_{ab} may be replaced by an equivalent Y-network, as shown in figure 14(b); and that the other three minor triangles, involving c,d, r_{cd} ; f,g, r_{fg} ; and h,k, r_{hk} , respectively, may be replaced in a similar manner. This transformation is merely the standard transformation of a π - to a T-network in communication theory or of a Δ - to a Y-network in power engineering.

By thus transforming the four minor triangles, the network of figure 14(a) is changed to that of figure 14(c), a simple Wheatstone bridge similar to that of figure 13, wherein

$$A' = A + fr_{fg} / (f + g + r_{fg}) + hr_{hk} / (h + k + r_{hk}) \quad (21)$$

$$B' = B + cr_{cd} / (c + d + r_{cd}) + kr_{hk} / (h + k + r_{hk}) \quad (22)$$

$$S' = S + ar_{ab}/(a + b + r_{ab}) + gr_{fg}/(f + g + r_{fg}) \quad (23)$$

$$R' = R + br_{ab}/(a + b + r_{ab}) + dr_{cd}/(c + d + r_{cd}) \quad (24)$$

$$G' = G + ab/(a + b + r_{ab}) + hk/(h + k + r_{hk}) \quad (25)$$

$$H' = cd/(c + d + r_{cd}) + fg/(f + g + r_{fg}) \quad (26)$$

The currents in the main ratio arms, in the detector circuit, and in the battery circuit are obtainable by inserting these values into equations (7) to (14).

Only the expression for the current in the detector circuit need be considered in detail. This current is

$$i_G = EN_G'/D' \quad (27)$$

where

$$\begin{aligned} N_G' = & AR - BS + \left(\frac{r_{ab}}{a+b+r_{ab}} \right) (bA - aB) + \left(\frac{r_{cd}}{c+d+r_{cd}} \right) (dA - cS) \\ & + \left(\frac{r_{fg}}{f+g+r_{fg}} \right) (fR - gB) + \left(\frac{r_{hk}}{h+k+r_{hk}} \right) (hR - kS) \\ & - ac \left[\frac{r_{ab} r_{cd}}{(a+b+r_{ab})(c+d+r_{cd})} \right] + bf \left[\frac{r_{ab} r_{fg}}{(a+b+r_{ab})(f+g+r_{fg})} \right] \\ & + dh \left[\frac{r_{cd} r_{hk}}{(c+d+r_{cd})(h+k+r_{hk})} \right] - gk \left[\frac{r_{fg} r_{hk}}{(f+g+r_{fg})(h+k+r_{hk})} \right] \\ & + (df - cg) \left[\frac{r_{cd} r_{fg}}{(c+d+r_{cd})(f+g+r_{fg})} \right] \\ & + (bh - ak) \left[\frac{r_{ab} r_{hk}}{(a+b+r_{ab})(h+k+r_{hk})} \right] \quad (28) \end{aligned}$$

and D' is obtained by substituting equations (21) to (26) in equation (8). The expression for D' consists solely of positive terms involving triple products of the circuit resistances and, when r_{ab} , r_{cd} , r_{fg} , r_{hk} are small compared with the other arms, a close approximation is obtained by omitting terms involving these quantities to the first and higher powers, thereby obtaining the approximate value

$$\begin{aligned}
 D' \text{ approx.} = D_0 = ABSR \left(\frac{1}{A} + \frac{1}{B} + \frac{1}{S} + \frac{1}{R} \right) &+ \left(G + \frac{ab}{a+b} + \frac{hk}{h+k} \right) (A+B)(S+R) \\
 &+ \left(\frac{cd}{c+d} + \frac{fg}{f+g} \right) (A+S)(B+R) \\
 &+ \left(G + \frac{ab}{a+b} + \frac{hk}{h+k} \right) \left(\frac{cd}{c+d} + \frac{fg}{f+g} \right) (A+B+S+R) \quad (29)
 \end{aligned}$$

Examination of equation (28) shows that first-order effects of the contact resistances r_{ab} , r_{cd} , r_{fg} , r_{hk} are eliminated if

$$bA - aB = 0 \quad (30)$$

$$dA - cS = 0 \quad (31)$$

$$fR - gB = 0 \quad (32)$$

$$hR - kS = 0 \quad (33)$$

Equations (30) to (33) are the conditions for practical elimination of contact-resistance error. If, in addition, the main arms of the bridge are adjusted so that

$$AR - BS = 0 \quad (34)$$

(the condition for balance of the simple Wheatstone bridge without contact resistances), the only current flowing in the detector circuit is that due to terms of the second order.

Residual Error Due to Contact Resistances

The multiple bridge considered so far has been one containing only the contact resistances r_{ab} , r_{cd} , r_{fg} , r_{hk} . However, reference to the circuits shown in figures 7(a), 7(c), and 8(d) will indicate that, in addition to the above contact resistances, there may also exist contact resistances in series with arms a , b , d , g . In the most general case, there may exist contact resistances in series with each of the arms a , b , c , d , f , g , h , k . These contact resistances will be denoted by Δa , Δb , Δc , etc. Examination of equation (28) will show that the introduction of this group of contact resistances (by writing $a + \Delta a$, $b + \Delta b$, $c + \Delta c$, etc. in place of a , b , c , etc., respectively) will produce only terms of second and higher orders.

Consequently, any multiple bridge whose arms satisfy equations (30) to (33) will remain free from first-order effects of the contact resistances and will possess only effects of the second and higher orders. An adequate evaluation of the second-order effect produced by the 12 contact resistances r_{ab} , r_{cd} , r_{fg} , r_{hk} , Δa , Δb , Δc , etc. (assuming those values are small compared to A , B , C , D , E , F , G , H , I , J , K , L , etc.) can be obtained by assuming that a deflection method is being used and finding the detector current caused by the presence of the contact resistances.

The problem will be treated by considering two cases. In the first case, starting with a balanced bridge (detector current = 0), there will be found the detector current i_{G1} caused by the addition of resistances ΔR , r_{ab} , r_{cd} , . . . , Δa , Δb , etc. In the second case, starting with the same balanced bridge, there will be found the detector current i_{G2} caused by the addition of resistance ΔR alone. This current is the "legitimate" measurement of the change in resistance of arm R , and is derivable mathematically from the preceding case merely by setting all the contact resistances equal to zero. The difference between the currents in the first and second cases will represent the error due to contact resistances. This error is expressible also as an additional "apparent ΔR " indicated by the detector.

To determine i_{G1} , the numerator and denominator of equation (27) may be imagined rewritten with $R + \Delta R$, $a + \Delta a$, $b + \Delta b$, etc., replacing R , a , b , etc., respectively. Because it is necessary to evaluate only those terms which will ultimately yield errors of the second and lower orders, the mathematical labor may be minimized by noting that, when the values of Δa , Δb , Δc , etc., are first inserted into equation (28) and equations (30) to (33) are then applied, the numerator N_{G1} will consist solely of $A\Delta R$ plus second-order terms because

1. The only zero-order term $(AR - BS)$ is equal to zero.

2. The only first-order terms besides $A\Delta R$ will be

$$\frac{r_{ab}}{a+b} (bA - aB), \frac{r_{cd}}{c+d} (dA - cS), \frac{r_{fg}}{f+g} (fR - gB), \frac{r_{hk}}{h+k} (hR - kS)$$

which are each equal to zero.

Consequently, in determining the fraction $A\Delta R/D'$, the denominator need be expanded only up to terms of the first order, and in determining the remaining fractions of i_{G1} , the denominator may be

written simply as D_0 , which is of zero order. Thus, if $\Delta N_{G'}$ represents the second-order terms that appear in $N_{G'}$ when all the contact resistances are introduced and, if ΔD represents the first-order terms that appear in D' when it is evaluated from equations (21) to (26), then

$$\Delta N_{G'} = \frac{\partial N_{G'}}{\partial a} \Delta a + \frac{\partial N_{G'}}{\partial b} \Delta b + \frac{\partial N_{G'}}{\partial c} \Delta c + \dots + bf \left[\frac{r_{ab} r_{fg}}{(a+b)(f+g)} \right] - ac \left[\frac{r_{ab} r_{cd}}{(a+b)(c+d)} \right] + dh \left[\frac{r_{cd} r_{hk}}{(c+d)(h+k)} \right] - gk \left[\frac{r_{fg} r_{hk}}{(f+g)(h+k)} \right] \quad (35)$$

$$\Delta D = \frac{\partial D_0}{\partial a} \Delta a + \frac{\partial D_0}{\partial b} \Delta b + \frac{\partial D_0}{\partial c} \Delta c + \dots + \frac{r_{ab}}{a+b} F_1 + \frac{r_{cd}}{c+d} F_2 + \frac{r_{fg}}{f+g} F_3 + \frac{r_{hk}}{h+k} F_4 \quad (36)$$

where F_1, F_2, F_3, F_4 are functions of $A, B, S, R, a, b, \dots, h, k$, and, in the evaluation of the partial derivatives from equations (28) and (29), $r_{ab}/(a+b+r_{ab})$ has been written simply as $r_{ab}/(a+b)$, etc.

The value of i_{G1} is then given by

$$i_{G1} = E \left[\frac{A\Delta R}{D_0 + \Delta D} + \frac{\Delta N_{G'}}{D_0} \right] = \frac{EAR}{D_0} \left[\frac{D_0}{D_0 + \Delta D} \left(\frac{\Delta R}{R} \right) + \frac{\Delta N_{G'}}{AR} \right] \quad (37)$$

and the value of i_{G2} is obtained from this equation by setting all the contact resistances equal to zero:

$$i_{G2} = \frac{EA\Delta R}{D_0} = \frac{EAR}{D_0} \left(\frac{\Delta R}{R} \right) \quad (38)$$

The difference between the two currents may then be written as

$$i_{G1} - i_{G2} = \frac{EAR}{D_0} \left[\frac{\Delta N_{G'}}{AR} - \frac{\Delta D}{D_0} \left(\frac{\Delta R}{R} \right) \right] \quad (39)$$

where, in the last term, ΔD has been dropped from the denominator because it would contribute only third-order terms.

Inserting equation (39) into the identity

$$i_{G1} \equiv i_{G2} + (i_{G1} - i_{G2}) \quad (40)$$

equation (37) may be placed in the form

$$i_{G1} = \frac{EAR}{D_0} \left[\frac{\Delta R}{R} + \eta_1 + \eta_2 \left(\frac{\Delta R}{R} \right) \right] \quad (41)$$

where

$$\eta_1 = \frac{\Delta N_{G1}}{AR} \quad \text{and} \quad \eta_2 = - \frac{\Delta D}{D_0} \quad (42)$$

The term EAR/D_0 is the sensitivity factor of the bridge, relating detector current to fractional change in R . The term $\Delta R/R$ represents the true resistance change in arm R and the last two terms within the brackets in equation (41) represent the total error in the measurement of $\Delta R/R$, expressed as the apparent additional fractional change in resistance of arm R . In the resulting equation

$$\text{Error} = \eta_1 + \eta_2 \left(\frac{\Delta R}{R} \right) \quad (43)$$

the quantities η_1 and η_2 are functions of the contact resistances and do not themselves contain ΔR ; η_1 represents the error present even when ΔR is zero and $\eta_2(\Delta R/R)$ represents the additional error present when there exists an initial unbalance ΔR . The explicit expressions for these errors in the measurement of $\Delta R/R$, as obtained from equations (35), (36), and (39), are

$$\begin{aligned} \eta_1 = & \frac{r_{ab}}{a+b} \left(\frac{\Delta b}{R} - \frac{\Delta a}{S} \right) + \frac{r_{cd}}{c+d} \left(\frac{\Delta d}{R} - \frac{\Delta c}{S} \right) + \frac{r_{fg}}{f+g} \left(\frac{\Delta f}{A} - \frac{\Delta g}{S} \right) + \frac{r_{hk}}{h+k} \left(\frac{\Delta h}{A} - \frac{\Delta k}{B} \right) \\ & + \left(\frac{bf}{AR} \times \frac{r_{ab}}{a+b} \times \frac{r_{fg}}{f+g} \right) - \left(\frac{ac}{AR} \times \frac{r_{ab}}{a+b} \times \frac{r_{cd}}{c+d} \right) \\ & + \left(\frac{dh}{AR} \times \frac{r_{cd}}{c+d} \times \frac{r_{hk}}{h+k} \right) - \left(\frac{gk}{AR} \times \frac{r_{fg}}{f+g} \times \frac{r_{hk}}{h+k} \right) \end{aligned} \quad (44)$$

and

$$\eta_2 = \left(\frac{r_{fg}}{f+g} \times \frac{f}{A} \right) + \left(\frac{r_{hk}}{h+k} \times \frac{h}{A} \right) - \frac{1}{D_0} \left[\frac{r_{ab}}{a+b} F_1 + \frac{r_{cd}}{c+d} F_2 + \frac{r_{fg}}{f+g} F_3 + \frac{r_{hk}}{h+k} F_4 \right. \\ \left. + \frac{b^2 \Delta a + a^2 \Delta b}{(a+b)^2} F_5 + \frac{k^2 \Delta h + h^2 \Delta k}{(h+k)^2} F_5 + \frac{d^2 \Delta c + c^2 \Delta d}{(c+d)^2} F_6 + \frac{g^2 \Delta f + f^2 \Delta g}{(f+g)^2} F_6 \right] \quad (45)$$

where

$$D_0 = \text{ABSR} \left(\frac{1}{A} + \frac{1}{B} + \frac{1}{S} + \frac{1}{R} \right) + G_0' (A+B)(S+R) + H_0 (A+S)(B+R) + G_0' H_0 (A+B+S+R) \quad (46)$$

$$G_0' = G + \frac{ab}{a+b} + \frac{hk}{h+k} \quad (47)$$

$$H_0 = \frac{cd}{c+d} + \frac{fg}{f+g} \quad (48)$$

$$F_1 = aB (A+B+S+R) + G_0' (A+B)(a+b) + H_0 b (A+S) + G_0' H_0 (a+b) \quad (49)$$

$$F_2 = dA (A+B+S+R) + H_0 (A+S)(c+d) + G_0' d (A+B) + G_0' H_0 (c+d) \quad (50)$$

$$F_3 = gB (A+B+S+R) + H_0 (B+R)(f+g) + G_0' g (A+B) + G_0' H_0 (f+g) \quad (51)$$

$$F_4 = kS (A+B+S+R) + G_0' (S+R)(h+k) + H_0' k (A+S) + G_0' H_0 (h+k) \quad (52)$$

$$F_5 = (A+B)(S+R) + H_0 (A+B+S+R) \quad (53)$$

$$F_6 = (A+S)(B+R) + G_0' (A+B+S+R) \quad (54)$$

Numerical evaluation of the error will be obtained for certain special cases of practical interest. For convenience, it will be assumed that the values of all contact resistances are equal. If this value is denoted as r , then equation (43) becomes

$$\text{Error} = K_1 r^2 + K_2 r \cdot (\Delta R/R) \quad (55)$$

where $K_1 r^2$ and $K_2 r$ are the values assumed by the functions η_1 and η_2 when all the contact resistances are set equal to r . In the cases itemized below, the values of the contact resistances will

be chosen either equal to r or to zero in such manner as to produce the maximum possible value of K_1 (that is, the greatest possible error in an initially balanced bridge). The value of K_2 will then be determined for the same values of contact resistance as those used in evaluating K_1 . In evaluating K_2 , it will be assumed that $G = 0$, because this condition always leads to a greater error. The resulting values of the total error in a bridge initially 1 percent out of balance generally will not be the maximum possible values, but they will be sufficiently close to the maximum to provide effective indication of the order of magnitude of the total error.

Case 1. - For the circuit of figure 8(a) (equivalent to fig. 15(a)), $f = g = h = k = r_{fg} = r_{hk} = 0$. For the circuits listed in table 1, table 2 lists the values of K_1 and K_2 computed for conditions that lead to the maximum value of K_1 . These conditions are generally

$$r_{ab} = r_{cd} = \Delta a = r$$

$$\Delta b = \Delta d = 0$$

Case 2. - For the circuit of figure 8(c) (equivalent to fig. 15(b)), $a = b = h = k = r_{ab} = r_{hk} = 0$. For the circuits listed in table 3, table 4 lists the values of K_1 and K_2 computed for conditions that lead to the maximum value of K_1 . These conditions are generally

$$r_{cd} = r_{fg} = \Delta g = r$$

$$\Delta d = 0$$

Case 3. - For the Kelvin bridge circuit of figure 8(b), $c = d = f = g = h = k = r_{cd} = r_{fg} = r_{hk} = 0$. For the circuits listed in table 5, table 6 lists the values of K_1 and K_2 computed for conditions that lead to the maximum value of K_1 . These conditions are

$$r_{ab} = \Delta b = r$$

Case 4. - For the circuit of figure 9(c) (equivalent to fig. 15(c)), $h = k = r_{hk} = 0$. For the circuits listed in table 7, table 8 lists the values of K_1 and K_2 computed for conditions that lead to the maximum value of K_1 . These conditions are

$$r_{ab} = r_{cd} = r_{fg} = \Delta a = \Delta g = r$$

$$\Delta b = \Delta d = 0$$

Solution for a High-Resistance Detector

When the detector resistance is very high compared to the resistance of the bridge arms, the detector becomes a voltage-sensitive rather than a current-sensitive device and, in place of equation (27), there should be used

$$e_G = E \frac{N_{G'}}{(D'/G)} \quad (56)$$

which, as G approaches infinity, becomes

$$e_G = EN_{G'}/\bar{D}' \quad (57)$$

where \bar{D}' is the coefficient of G in the equation for D' .

Evaluation of the second-order error by a treatment similar to that of the preceding section leads to the result that the apparent fractional change in R , which is actually caused by the presence of contact resistances, is given by

$$\text{Error} = \eta_1 + \bar{\eta}_2 (\Delta R/R) \quad (58)$$

where the error η_1 , at balance, remains unchanged from the case of a low-resistance detector and is given by

$$\begin{aligned} \eta_1 = & \frac{r_{ab}(\Delta b}{a+b} - \frac{\Delta a}{S}) + \frac{r_{cd}(\Delta d}{c+d} - \frac{\Delta c}{S}) + \frac{r_{fg}(\Delta f}{f+g} - \frac{\Delta g}{S}) + \frac{r_{hk}(\Delta h}{h+k} - \frac{\Delta k}{B}) \\ & + \left(\frac{bf}{AR} \times \frac{r_{ab}}{a+b} \times \frac{r_{fg}}{f+g} \right) - \left(\frac{ac}{AR} \times \frac{r_{ab}}{a+b} \times \frac{r_{cd}}{c+d} \right) \\ & + \left(\frac{dh}{AR} \times \frac{r_{cd}}{c+d} \times \frac{r_{hk}}{h+k} \right) - \left(\frac{gk}{AR} \times \frac{r_{fg}}{f+g} \times \frac{r_{hk}}{h+k} \right) \end{aligned} \quad (59)$$

The additional error caused by the presence of an initial unbalance $\Delta R/R$ is now $\bar{\eta}_2(\Delta R/R)$ where

$$\bar{\eta}_2 = \left(\frac{rfg}{f+g} \times \frac{f}{A} \right) + \left(\frac{r_{hk}}{h+k} \times \frac{h}{A} \right) - \frac{1}{D_0} \left[\frac{r_{ab}}{a+b} \bar{F}_1 + \frac{r_{cd}}{c+d} \bar{F}_2 + \frac{rfg}{f+g} \bar{F}_3 + \frac{r_{hk}}{h+k} \bar{F}_4 + \frac{d^2 \Delta c + c^2 \Delta d}{(c+d)^2} \bar{F}_6 + \frac{g^2 \Delta f + f^2 \Delta g}{(f+g)^2} \bar{F}_6 \right] \quad (60)$$

and

$$\bar{D}_0 = (A+B)(S+R) + H_0 (A+B+S+R) \quad (61)$$

$$\bar{H}_0 = \frac{cd}{c+d} + \frac{fg}{f+g} \quad (62)$$

$$\bar{F}_1 = (a+b)(A+B+H_0) \quad (63)$$

$$\bar{F}_2 = d(A+B) + H_0(c+d) \quad (64)$$

$$\bar{F}_3 = g(A+B) + H_0(f+g) \quad (65)$$

$$\bar{F}_4 = (h+k)(S+R+H_0) \quad (66)$$

$$\bar{F}_6 = A+B+S+R \quad (67)$$

For the special case where all contact resistances are equal, the analog of equation (55) is

$$\text{Error} = K_1 r^2 + \bar{K}_2 r (\Delta R/R) \quad (68)$$

For the bridges listed in tablos 1, 3, 5, and 7, the value of \bar{K}_2 is less than the value of K_2 in equation (55), so that no numerical listing has been presented for the case when G approaches infinity.

Accuracy Requirements in Design of a Multiple Bridge

In constructing a multiple-bridge circuit, it is necessary to know the required accuracy of adjustment of the resistors in the various arms. It is obvious that the ratio between resistors in the main bridge must be accurate to the same percentage as the

smallest percentage change in arm R that it is desired to measure. On the other hand, the auxiliary ratio arms do not require this accuracy; in fact, if the contact resistances r_{ab} , r_{cd} , r_{fg} , r_{hk} were zero, the values of the auxiliary ratio arms would be immaterial in any null method and would then affect only the sensitivity of the bridge. The question of what accuracy is required in the auxiliary ratios is the converse of the question of what effect is produced by a given change in these ratios and the latter effect has already been stated in equations (43), (44), and (45). For an initially balanced bridge, the effect is given by the first four terms of equation (44). Roughly speaking, the accuracy required in the auxiliary ratios is less stringent than the accuracy desired in the measurement of R by a factor of the order of magnitude of the ratio between the resistance of one of the bridge arms and the probable contact resistance. Thus, assume that the auxiliary ratio a/b is in error by p percent so that, instead of a/b , the ratio is $(a/b)(1 + 0.01 p)$. This ratio may be written as

$$\frac{a}{b} (1 + 0.01 p) = \frac{a(1 + \Delta a/a)}{b(1 + \Delta b/b)} \cong \frac{a}{b} \left(1 + \frac{\Delta a}{a} - \frac{\Delta b}{b} \right) \quad (69)$$

From equation (44), treating only the initially balanced bridge for simplicity, the error in the measurement of $\Delta R/R$, due to the change in a and b, is

$$\left(\frac{r_{ab}}{R} \times \frac{\Delta b}{a+b} \right) - \left(\frac{r_{ab}}{S} \times \frac{\Delta a}{a+b} \right) = \left(r_{ab} \times \frac{b}{R} \times \frac{\Delta b/b}{a+b} \right) - \left(r_{ab} \times \frac{a}{S} \times \frac{\Delta a/a}{a+b} \right) \quad (70)$$

Because $b/R = a/S$ and because $\Delta a/a - \Delta b/b = 0.01 p$, the error becomes

$$r_{ab} \times \frac{b}{R} \times \frac{\Delta b/b - \Delta a/a}{a+b} = \frac{r_{ab}}{R} \times \frac{b}{a+b} \times 0.01 p \quad (71)$$

If $a = b$, the percentage error becomes

$$- \frac{r_{ab}}{2R} p$$

Similar analyses hold for the other auxiliary ratio arms. Consequently, in an equal-arm main bridge possessing two pairs of auxiliary ratio arms, the following proportion would hold:

$$\frac{\text{Permissible percentage error in auxiliary ratios}}{\text{Permissible percentage error in measurement of R}} = \frac{R}{r} \quad (72)$$

where r_c is the probable contact resistance. It is important to note that the denominator of the left-hand side of this equation is the permissible percentage error in measurement of R and not the permissible percentage error in measurement of $\Delta R/R$. It is also to be noted that only the ratio between any pair of auxiliary resistors such as a,b or c,d must be held within the limits previously stated and that the actual value of those resistors is not critical.

REFERENCE

1. de Forest, A. V., and Leaderman, H.: The Development of Electrical Strain Gages. NACA TN No. 744, 1940.

TABLE 1. - REPRESENTATIVE RESISTANCE VALUES FOR MULTIPLE-BRIDGE CIRCUIT
 FOR ELIMINATING CONTACT-RESISTANCE ERRORS AT TWO ADJACENT BRIDGE
 CORNERS FOR STRAIN GAGES OF 100, 500, AND 1000 OHMS

Bridge	Resistance in main ratio arms, ohms				Resistance in auxiliary ratio arms, ohms			
	R	S	A	B	a	b	c	d
1	100	100	1000	1000	1000	1000	1000	100
2	100	1000	1000	100	1000	100	1000	1000
3	500	500	500	500	1000	1000	1000	1000
4	500	500	1000	1000	1000	1000	1000	500
5	500	1000	1000	500	1000	500	1000	1000
6	1000	1000	1000	1000	1000	1000	1000	1000
7	1000	1000	100	100	1000	1000	100	1000

TABLE 2. - ERRORS CAUSED BY CONTACT RESISTANCE r AT EACH CONTACT IN
 MULTIPLE-BRIDGE CIRCUITS OF TABLE 1 COMPARED WITH ERRORS THAT WOULD
 OCCUR IN SAME MAIN BRIDGE WITHOUT AUXILIARY ARMS (SEE FIG. 8(a))

Bridge	^a Constants in equation for error in multiple bridge [Error = $K_1 r^2 + K_2 r (\Delta R/R)$]		^a Apparent $\Delta R/R$ produced by 1-ohm contact resistance (ohms per megohm)		
	K_1	K_2 (b)	Wheatstone bridge	Multiple bridge	
				$\frac{\Delta R}{R} = 0$	$\frac{\Delta R}{R} = 0.01$
1	0.95×10^{-5}	-7.46×10^{-3}	20,000	-10	-65
2	.95	-7.44	20,000	10	-65
^c 3	-.20	-1.75	4,000	-2	-20
4	.17	-1.95	4,000	-2	-19
5	.17	-1.95	4,000	2	-18
6	.08	-1.17	2,000	-1	-11
7	.10	-1.42	2,000	-1	-13

^aComputed for conditions leading to maximum possible error in an initially balanced bridge. Unless otherwise noted, these conditions are $r_{ab} = r_{cd} = \Delta b = \Delta d = r$; $\Delta a = 0$.

^bResistance in detector arm is zero.

^cConditions for maximum value of K_1 are $r_{ab} = r_{cd} = \Delta a = r$; $\Delta b = \Delta d = 0$.

**TABLE 3. - REPRESENTATIVE RESISTANCE VALUES FOR MULTIPLE-BRIDGE CIRCUIT
 FOR ELIMINATING CONTACT-RESISTANCE ERRORS AT TWO OPPOSITE BRIDGE
 CORNERS FOR STRAIN GAGES OF 100, 500, AND 1000 OHMS**

Bridge	Resistance in main ratio arms, ohms				Resistance in auxiliary ratio arms, ohms			
	R	S	A	B	c	d	f	g
8	100	100	100	100	1000	1000	1000	1000
9	100	500	500	100	1000	1000	1000	1000
10	500	500	500	500	500	500	500	500
11	500	500	500	500	1000	1000	1000	1000
12	500	500	1000	1000	1000	500	1000	500
13	500	100	100	500	1000	1000	1000	1000
14	1000	1000	1000	1000	1000	1000	1000	1000
15	1000	1000	500	500	500	1000	500	1000

**TABLE 4. - ERRORS CAUSED BY CONTACT RESISTANCE r AT EACH CONTACT IN
 MULTIPLE-BRIDGE CIRCUITS OF TABLE 3 COMPARED WITH ERRORS THAT WOULD
 OCCUR IN SAME MAIN BRIDGE WITHOUT AUXILIARY ARMS (SEE FIG. 8(c))**

Bridge	^a Constants in equation for error in multiple bridge [Error = $K_1 r^2 + K_2 r (\Delta R/R)$]		^a Apparent $\Delta R/R$ produced by 1-ohm contact resistance (ohms per megohm)		
	K_1	K_2 (b)	Wheatstone bridge	Multiple bridge	
				$\frac{\Delta R}{R} = 0$	$\frac{\Delta R}{R} = 0.01$
8	-0.50×10^{-5}	-5.23×10^{-3}	20,000	-5	-57
^c 9	.50	-5.24	20,000	5	-47
10	-.20	-1.25	4,000	-2	-15
11	-.10	-1.17	4,000	-1	-13
12	-.13	-1.00	4,000	-1	-11
13	-.50	-1.24	4,000	-5	-17
14	-.05	-.63	2,000	-.5	-7
15	-.07	-.75	2,000	-1	-8

^aComputed for conditions leading to maximum possible error in an initially balanced bridge. Unless otherwise noted, these conditions are $r_{cd} = r_{fg} = \Delta g = r$; $\Delta d = 0$.

^bResistance in detector arm is zero.

^cConditions for maximum value of K_1 are $r_{cd} = r_{fg} = \Delta d = r$; $\Delta g = 0$.

TABLE 5. - REPRESENTATIVE RESISTANCE VALUES FOR KELVIN BRIDGE CIRCUIT
 FOR ELIMINATING CONTACT-RESISTANCE ERRORS AT ONE BRIDGE
 CORNER FOR STRAIN GAGES OF 100, 500, AND 1000 OHMS

Bridge	Resistance in main ratio arms, ohms				Resistance in auxiliary ratio arms, ohms	
	R	S	A	B	a	b
16	100	100	100	100	1000	1000
17	100	100	1000	1000	1000	1000
18	100	1000	1000	100	1000	100
19	500	500	500	500	1000	1000
20	500	500	1000	1000	1000	1000
21	500	1000	1000	500	1000	500
22	1000	1000	1000	1000	1000	1000
23	1000	1000	100	100	1000	1000

TABLE 6. - ERRORS CAUSED BY CONTACT RESISTANCE r AT EACH CONTACT IN
 KELVIN BRIDGE CIRCUITS OF TABLE 5 COMPARED WITH ERRORS THAT WOULD
 OCCUR IN SAME MAIN BRIDGE WITHOUT AUXILIARY ARMS (SEE FIG. 8(b))

Bridge	^a Constants in equation for error in multiple bridge [Error = $K_1 r^2 + K_2 r (\Delta R/R)$]		^a Apparent $\Delta R/R$ produced by 1-ohm contact resistance (ohms per megohm)		
	K_1	K_2 (b)	Wheatstone bridge	Multiple bridge	
				$\frac{\Delta R}{R} = 0$	$\frac{\Delta R}{R} = 0.01$
16	0.50×10^{-5}	-5.42×10^{-3}	10,000	5	-49
17	.50	-5.24	10,000	5	-47
18	.91	-3.94	10,000	9	-30
19	.10	-1.25	2,000	1	-12
20	.10	-1.20	2,000	1	-11
21	.13	-1.11	2,000	1	-10
22	.05	-.67	1,000	.5	-6
23	.05	-.74	1,000	.5	-7

^aComputed for conditions leading to maximum possible error in an initially balanced bridge: $r_{ab} = \Delta b = r$.

^bResistance in detector arm is zero.

TABLE 7. - REPRESENTATIVE RESISTANCE VALUES FOR MULTIPLE-BRIDGE CIRCUIT
 FOR ELIMINATING CONTACT-RESISTANCE ERRORS AT THREE BRIDGE
 CORNERS FOR STRAIN GAGES OF 100, 500, AND 1000 OHMS

Bridge	Resistance in main ratio arms, ohms				Resistance in auxiliary ratio arms, ohms					
	R	S	A	B	a	b	c	d	f	g
24	100	100	100	100	1000	1000	1000	1000	1000	1000
25	100	100	1000	1000	1000	1000	1000	100	1000	100
26	500	500	500	500	500	500	500	500	500	500
27	500	500	500	500	1000	1000	1000	1000	1000	1000
28	500	500	1000	1000	1000	1000	1000	500	1000	500
29	1000	1000	1000	1000	1000	1000	1000	1000	1000	1000
30	1000	1000	500	500	1000	1000	500	1000	500	1000
31	1000	1000	100	100	1000	1000	100	1000	100	1000

TABLE 8. - ERRORS CAUSED BY CONTACT RESISTANCE r AT EACH CONTACT IN
 MULTIPLE-BRIDGE CIRCUITS OF TABLE 7 COMPARED WITH ERRORS THAT WOULD
 OCCUR IN SAME MAIN BRIDGE WITHOUT AUXILIARY ARMS (SEE FIG. 9(c))

Bridge	^a Constants in equation for error in multiple bridge [Error = $K_1 r^2 + K_2 r (\Delta R/R)$]		^a Apparent $\Delta R/R$ produced by 1-ohm contact resistance (ohms per megohm)		
	K_1	K_2 (b)	Wheatstone bridge	Multiple bridge	
				$\frac{\Delta R}{R} = 0$	$\frac{\Delta R}{R} = 0.01$
24	-1.00×10^{-5}	-4.20×10^{-3}	20,000	-10	-52
25	-1.41	-5.71	20,000	-14	-71
26	-.40	-2.00	4,000	-4	-24
27	-.20	-1.58	4,000	-2	-18
28	-.23	-1.60	4,000	-2	-18
29	-.10	-1.00	2,000	-1	-11
30	-.12	-1.09	2,000	-1	-12
31	-.14	-1.21	2,000	-1	-14

^aComputed for conditions leading to maximum possible error in an initially balanced bridge: $r_{ab} = r_{cd} = r_{fg} = \Delta a = \Delta g = r$;

$\Delta b = \Delta d = 0$.

^bResistance in detector arm is zero.

NACA TN No. 1031

Figs. 1, 2

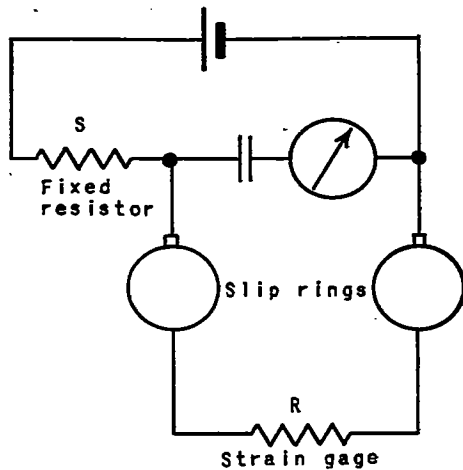

(a) Actual circuit.

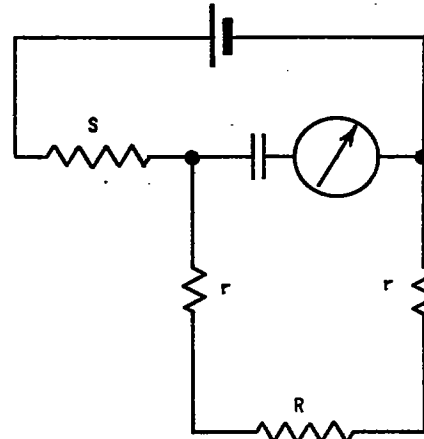

(b) Equivalent circuit.

Figure 1. - Series circuit for measurement of alternating strains through slip rings.

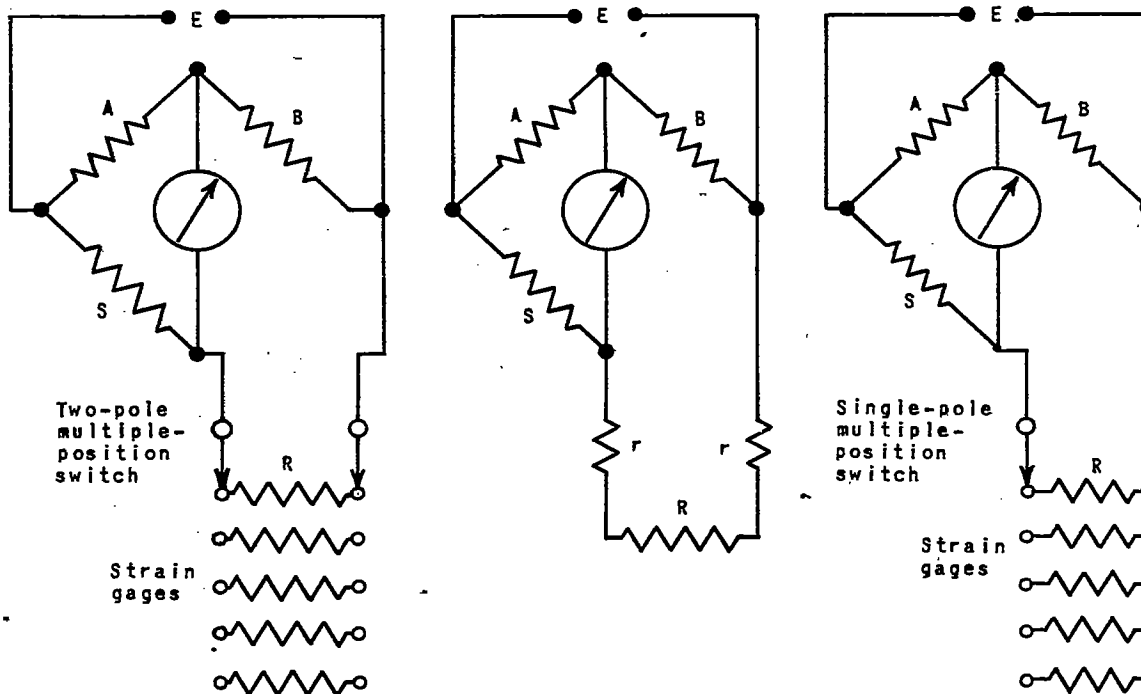

(a) Actual circuit using two-pole switch.

(b) Equivalent circuit using two-pole switch.

(c) Actual circuit using single-pole switch.

Figure 2. - Wheatstone bridge for multiple-point strain measurements.

Fig. 3

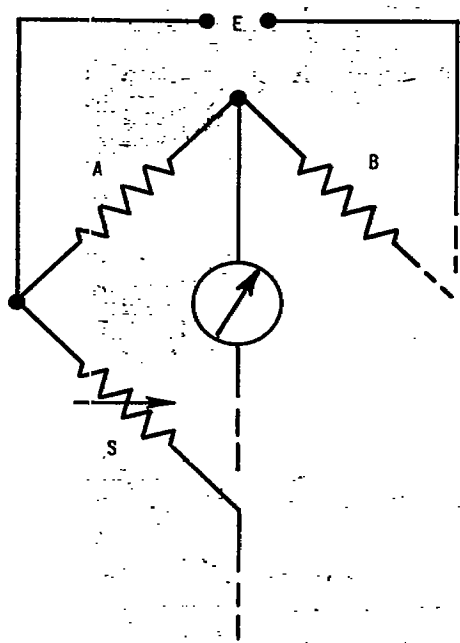

(a) Varying the resistance of the reference arm.

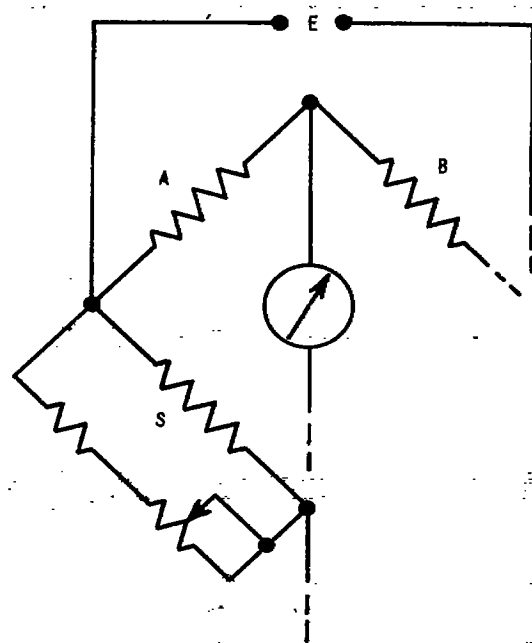

(b) Shunting the reference resistor.

NATIONAL ADVISORY
COMMITTEE FOR AERONAUTICS

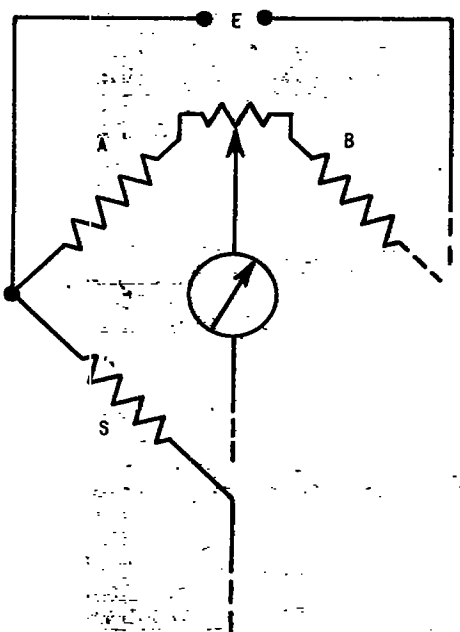

(c) Varying the ratio-arm setting.

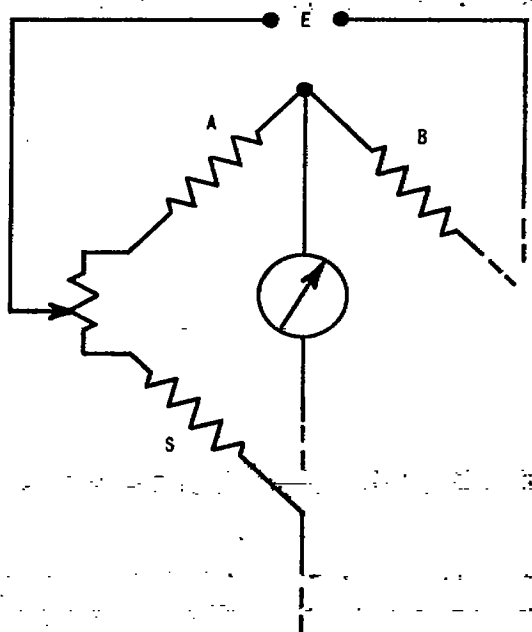

(d) Varying the position of the battery connection.

Figure 3. - Standard methods of balancing the Wheatstone bridge circuit for resistance strain gages.

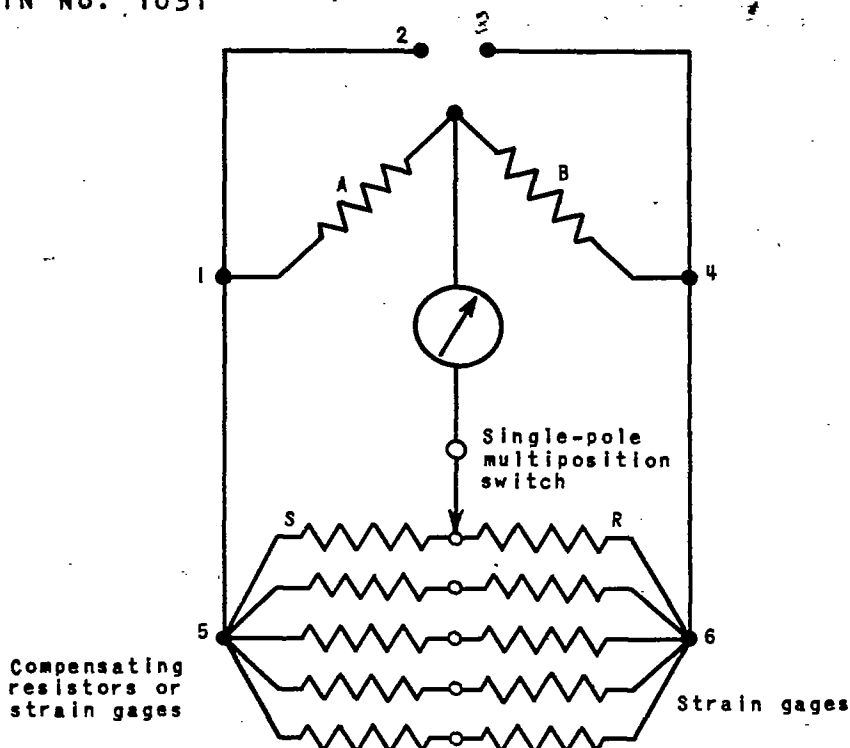
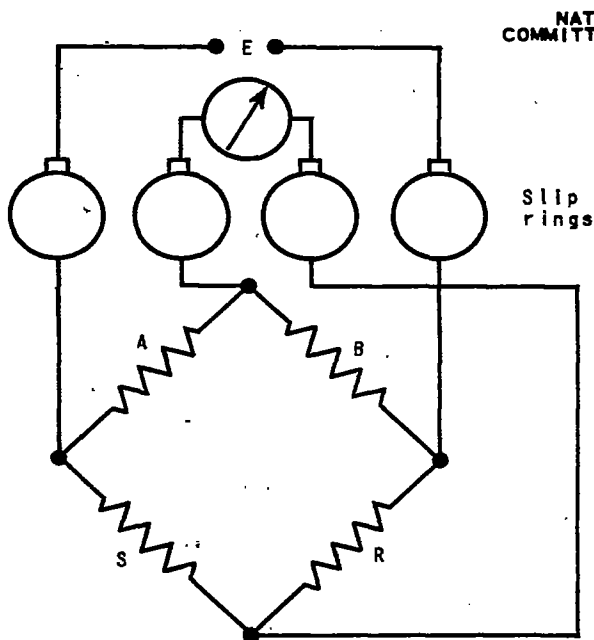

Figure 4. - Multiple-point strain-measuring circuit, free from contact-resistance errors, using a separate compensating resistor for each strain gage.



NATIONAL ADVISORY
 COMMITTEE FOR AERONAUTICS

Figure 5. - Circuit for strain measurement through slip rings, free from contact-resistance errors.

Fig. 6

NAQA TN No. 1031

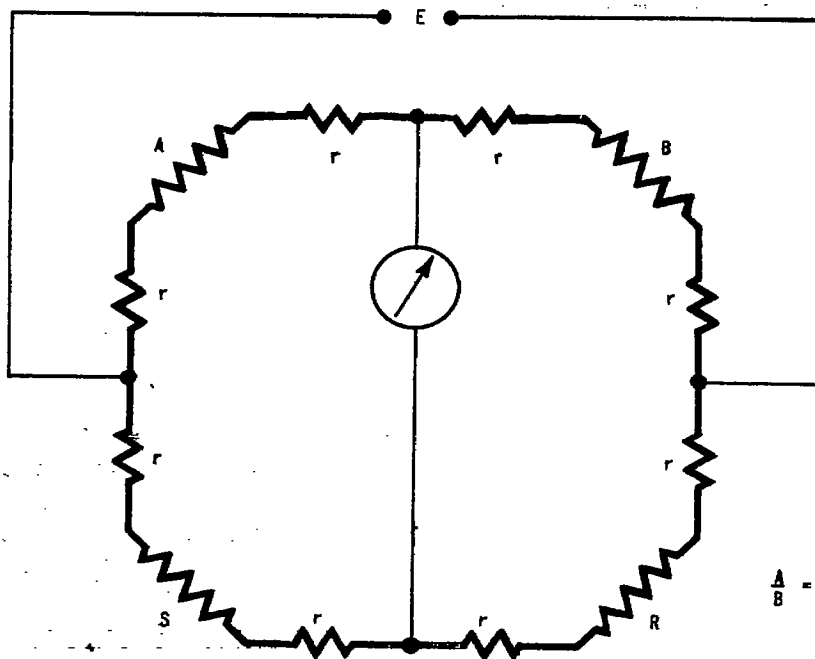

$$\frac{A}{B} = \frac{S}{R}$$

(a) Original Wheatstone bridge.

NATIONAL ADVISORY
 COMMITTEE FOR AERONAUTICS

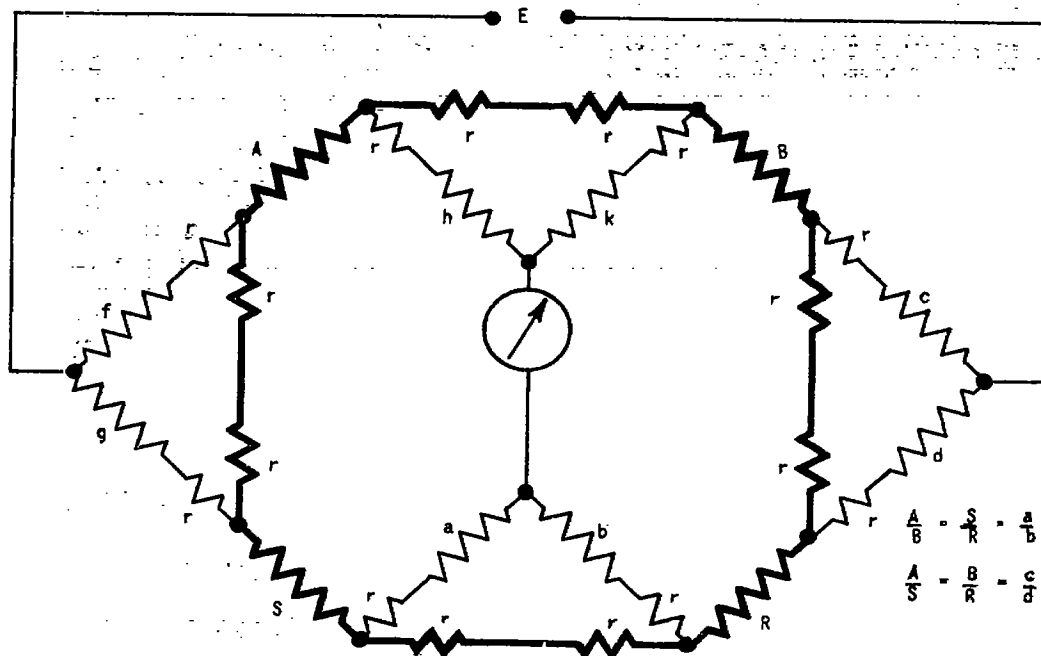

$$\frac{A}{B} = \frac{S}{R} = \frac{a}{b} = \frac{h}{k}$$

$$\frac{A}{S} = \frac{B}{R} = \frac{c}{d} = \frac{f}{g}$$

(b) Original contact resistances bridged by auxiliary arms.

Figure 6. - Construction of the multiple bridge.

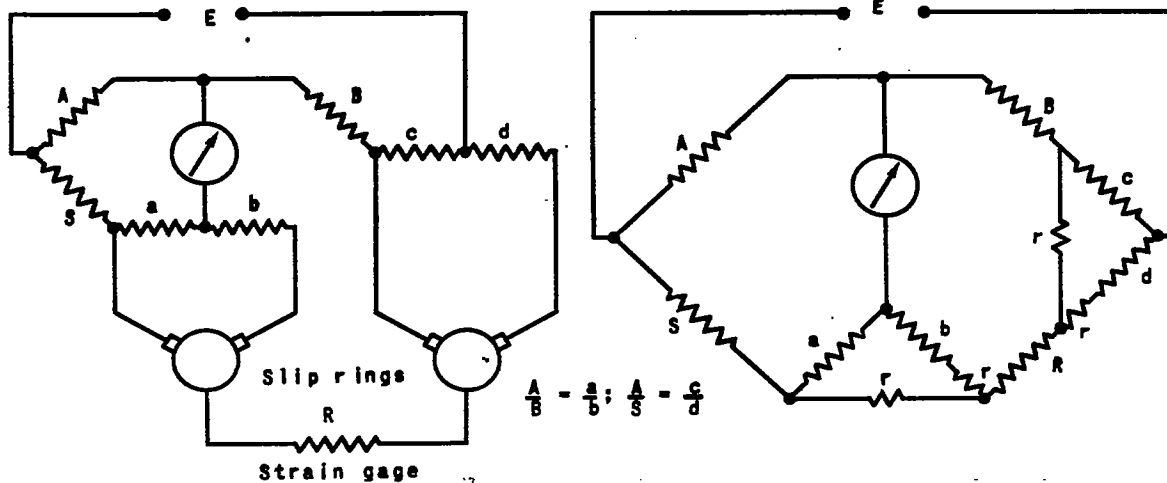

(a) Actual circuit, strain gage only on rotating member.

(b) Equivalent circuit of figure 7(a).

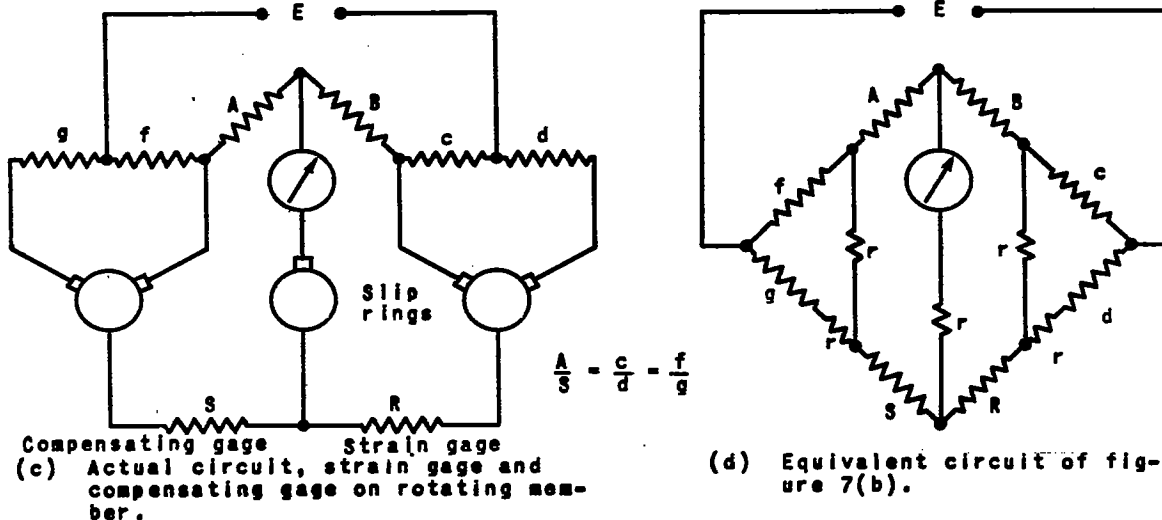

(c) Actual circuit, strain gage and compensating gage on rotating member.

(d) Equivalent circuit of figure 7(b).

Figure 7. - Multiple-bridge circuits for elimination of contact-resistance errors in measurements through slip rings.

Fig. 8

NACA TN No. 1031

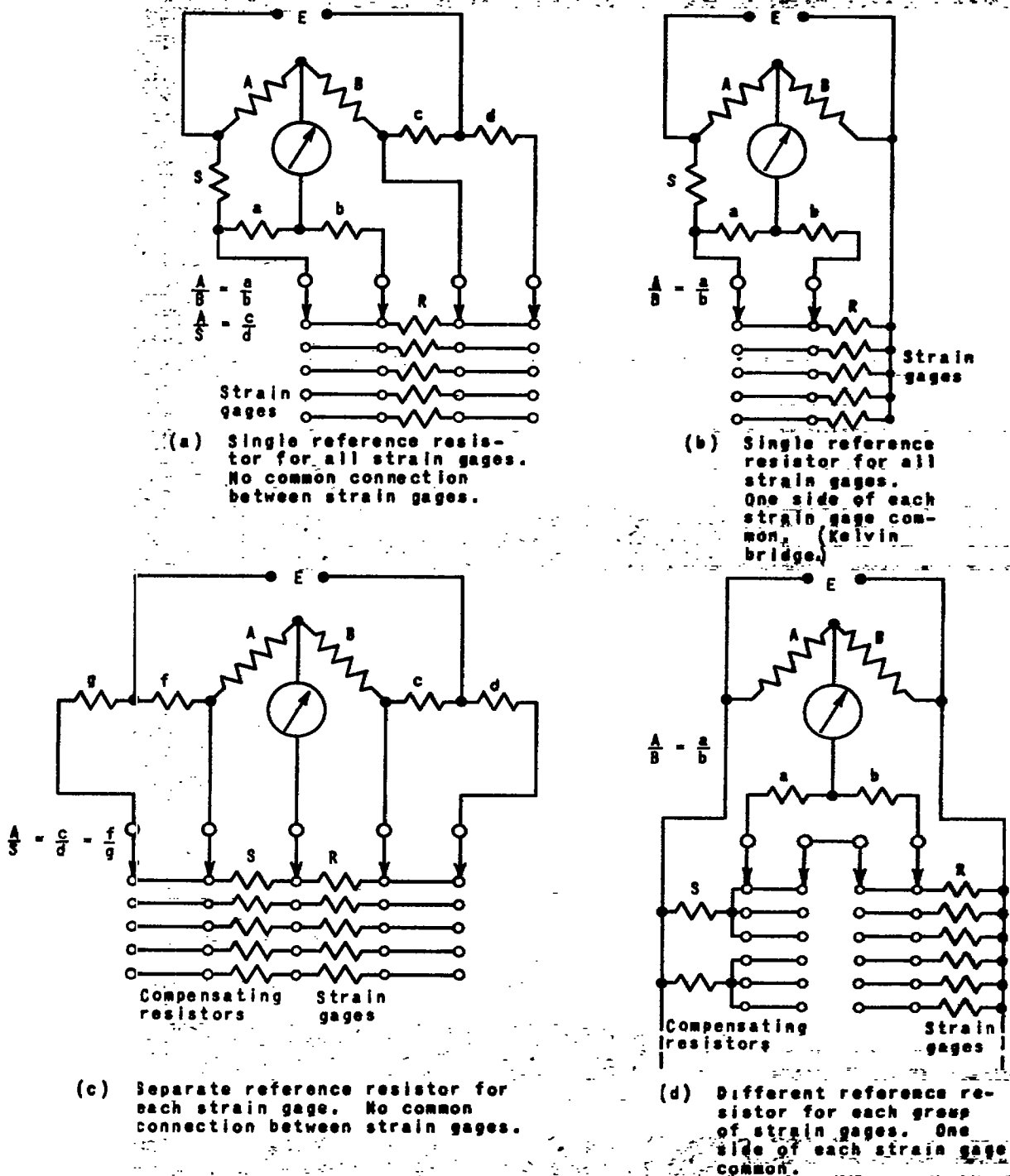
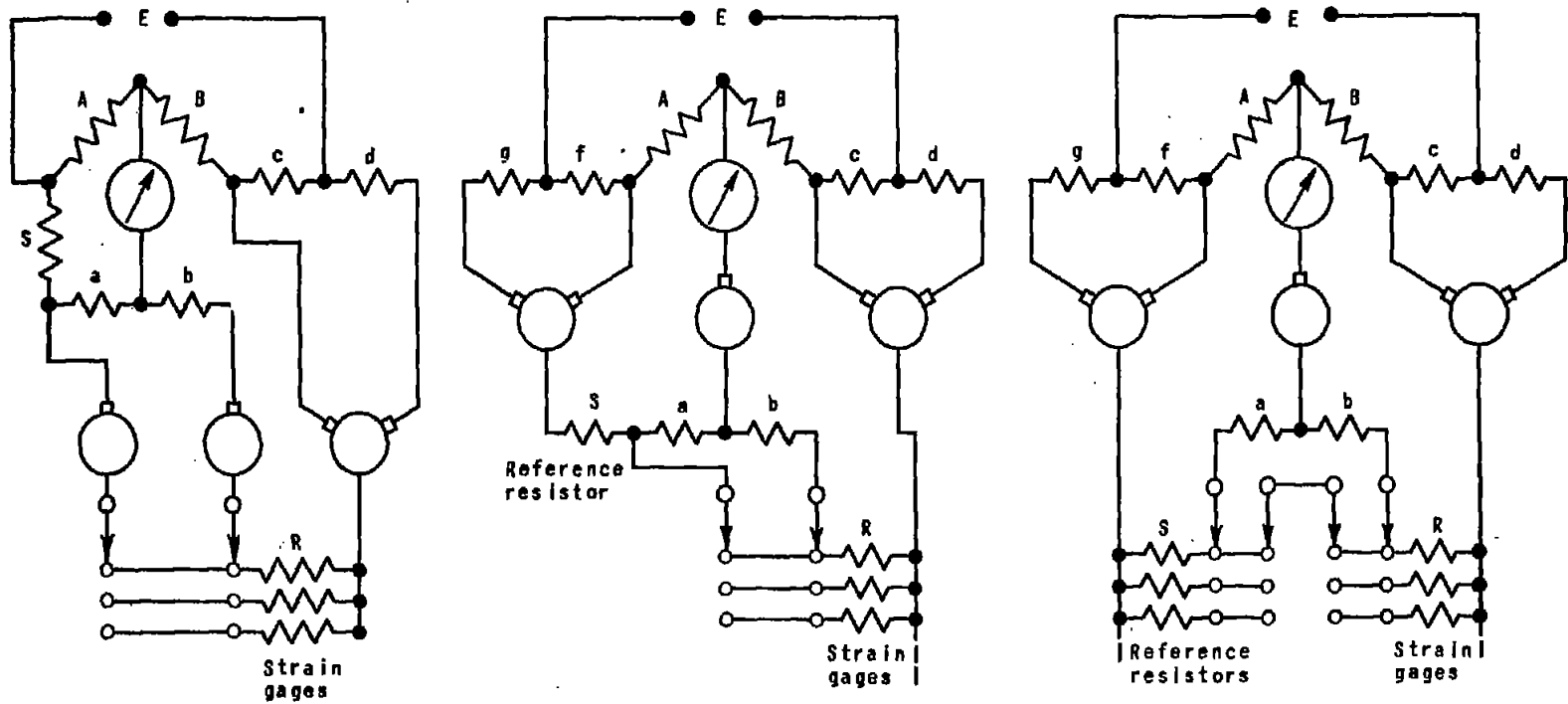

Figure 8. - Multiple-bridge circuits for elimination of contact-resistance errors in multiple-point measurements using selector switches.



NACA TN No. 1051

(a) Common reference resistor for all strain gages. Reference resistor on fixed member. (Three slip rings and two-pole switch required.)

(b) Common reference resistor for all strain gages. Reference resistor on rotating member. (Three slip rings and two-pole switch required.)

(c) Separate reference resistor for each strain gage. Reference resistor on rotating member. (Three slip rings and four-pole switch required.)

Figure 9. - Multiple-bridge circuits for multiple-point measurements through slip rings.

Fig. 10

NACA TN No. 1031

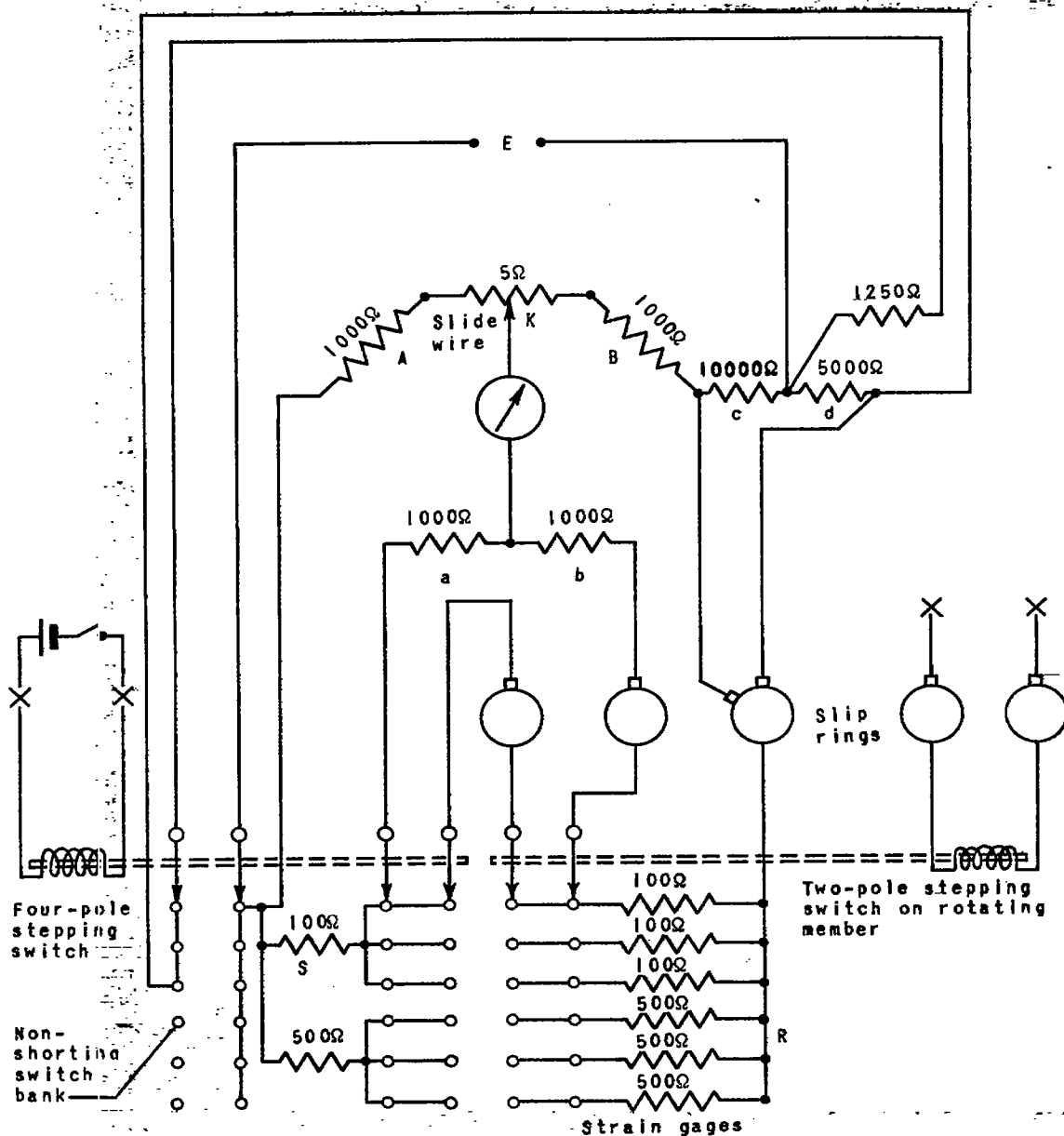
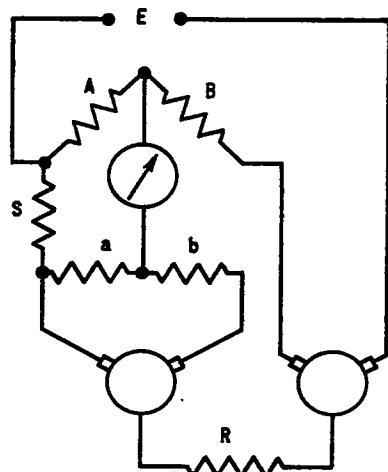
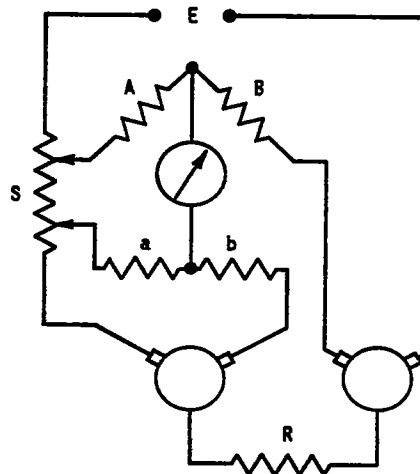

Figure 10. - Complete wiring diagram for multiple-point measurements on a rotating member carrying strain gages of two different nominal resistances.



(a) Basic circuit.



(b) Method of balancing by moving potential taps on reference resistor.

Figure 11. - Kelvin bridge type circuits for use with high-resistance detector.

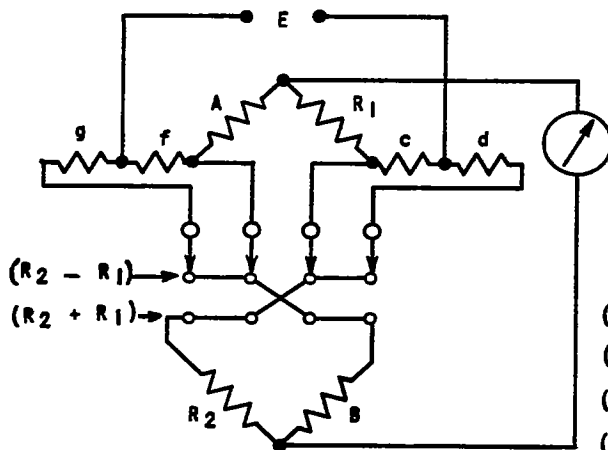

(a) Circuit for sum and difference of two strains.

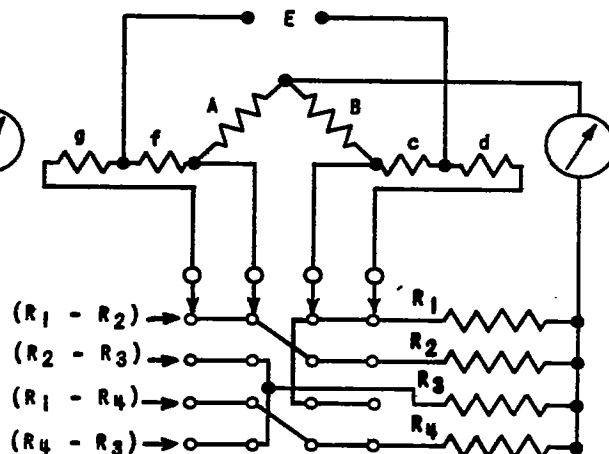

(b) Circuit for differences between any pair out of a group of four strains.

Figure 12. - Elementary switching circuits for direct measurements of sums and differences of strains.

Fig. 13

NACA TN No. 1031

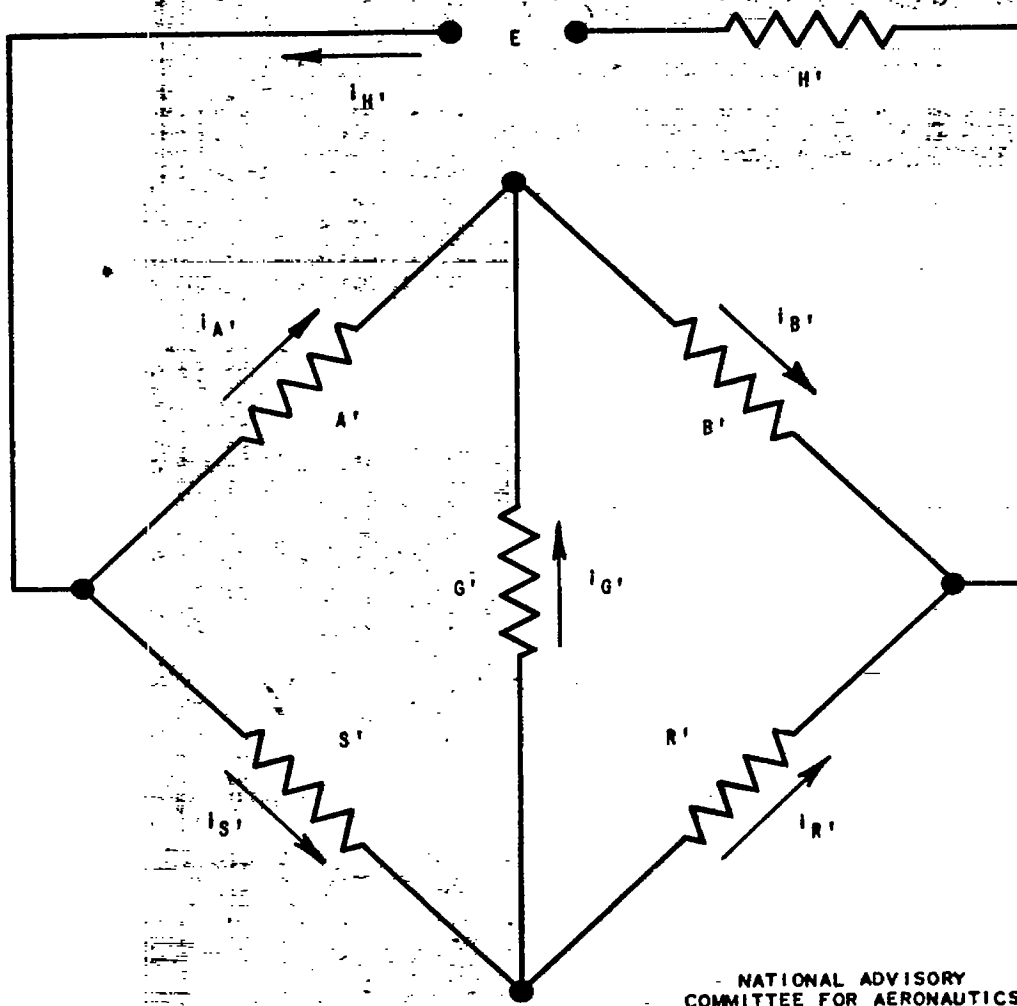

NATIONAL ADVISORY
COMMITTEE FOR AERONAUTICS

Figure 13. - Wheatstone bridge circuit.

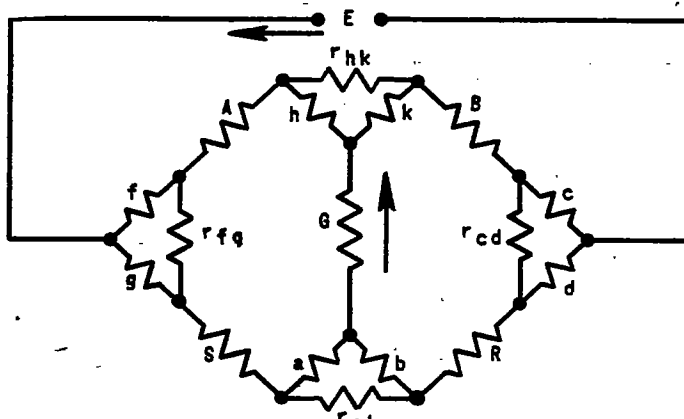

(a) Actual bridge circuit.



(b) Transformation of minor triangles.

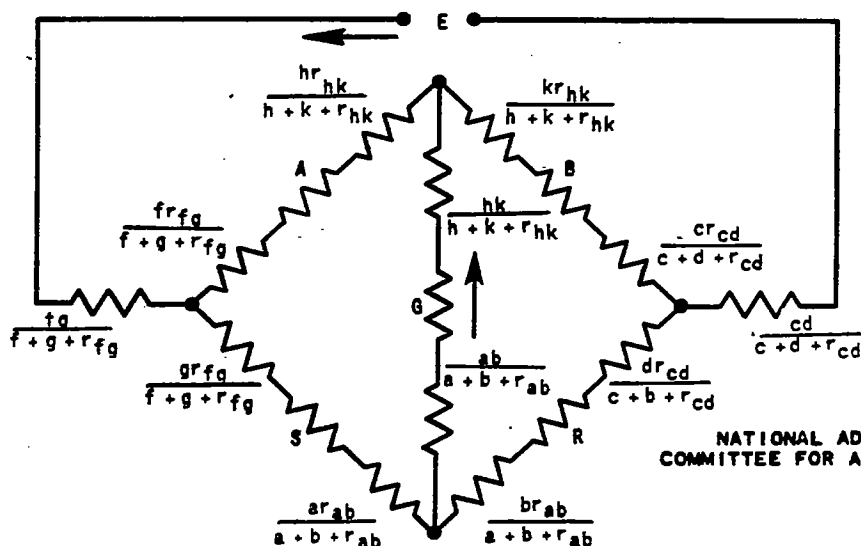

NATIONAL ADVISORY
 COMMITTEE FOR AERONAUTICS

(c) Equivalent network of multiple-bridge circuit.

Figure 14. - Multiple-bridge circuit.

Fig. 15

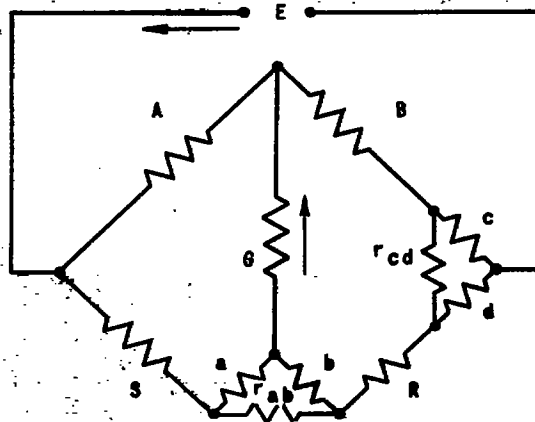

(a) Case 1. Contact resistances at two adjacent bridge corners.

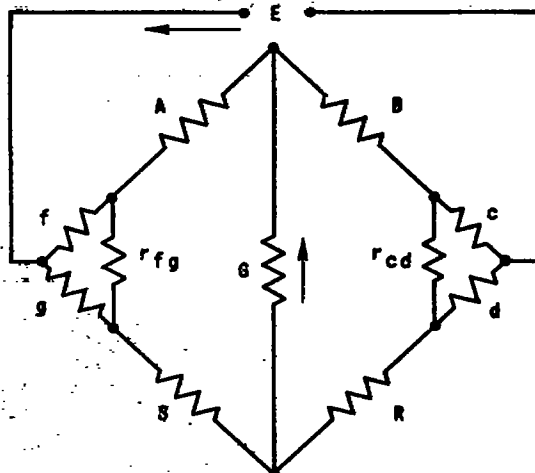

(b) Case 2. Contact resistances at two opposite bridge corners.

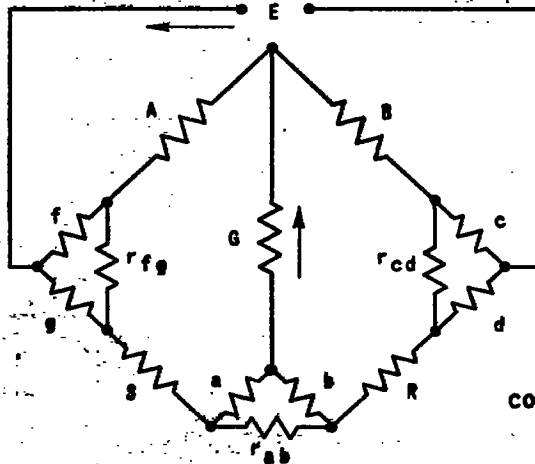

(c) Case 4. Contact resistances at three bridge corners.

NATIONAL ADVISORY
 COMMITTEE FOR AERONAUTICS

Figure 15. - Special cases of the multiple bridge.