

8501

NACA TN 2075

TECH LIBRARY KAFB, NM



0065242

NATIONAL ADVISORY COMMITTEE FOR AERONAUTICS

TECHNICAL NOTE 2075

FREE-FLIGHT-TUNNEL INVESTIGATION OF DYNAMIC LONGITUDINAL
STABILITY AS INFLUENCED BY THE STATIC STABILITY MEASURED
IN WIND-TUNNEL FORCE TESTS UNDER CONDITIONS
OF CONSTANT THRUST AND CONSTANT POWER

By Robert O. Schade

Langley Aeronautical Laboratory
Langley Air Force Base, Va.



Washington
April 1950

AFMDC
TECHNICAL LIBRARY
AFL 2811

319.98 4/1



0065242

NATIONAL ADVISORY COMMITTEE FOR AERONAUTICS

TECHNICAL NOTE 2075

FREE-FLIGHT-TUNNEL INVESTIGATION OF DYNAMIC LONGITUDINAL
STABILITY AS INFLUENCED BY THE STATIC STABILITY MEASURED
IN WIND-TUNNEL FORCE TESTS UNDER CONDITIONS
OF CONSTANT THRUST AND CONSTANT POWER

By Robert O. Schade

SUMMARY

An investigation has been conducted in the Langley free-flight tunnel to determine the dynamic longitudinal stability as influenced by the static stability measured in wind-tunnel force tests under conditions of constant thrust and constant power. The amount of static stability was varied in the flight tests by changing the power applied to a pusher propeller with an offset thrust axis and by shifting the center of gravity of the model. Force tests were made for the purpose of determining the amount of static stability for all flight-test conditions.

The results of the investigation show that reductions in constant-thrust static stability caused a decrease in the longitudinal steadiness (the reaction of the airplane to disturbances at essentially constant airspeed). When the constant-thrust static margin was reduced to zero, the flight behavior became very poor. For a given value of constant-thrust static margin, however, no reduction in longitudinal steadiness was noticeable as the constant-power static margin was reduced. Even with negative values of constant-power static margin good flight behavior was obtained as long as the constant-thrust static margin was adequate. These results are in agreement with previous studies which indicated that the longitudinal steadiness of airplanes is affected to a much greater extent by changes in constant-thrust static margin than by changes in constant-power static margin.

INTRODUCTION

In discussions of the power-on longitudinal stability of propeller-driven airplanes confusion has sometimes resulted from the use of two different methods of designating the amount of static stability of an airplane as determined from wind-tunnel force tests. As pointed out in

reference 1, these designations differ in that one refers to the static stability measured at a constant-thrust condition which is interpreted by the pilot in terms of control movement or control force required to effect a given acceleration at a constant speed, whereas the other refers to the static stability as measured at a constant-power condition which is manifested as stick-force or stick-position stability. A constant-thrust condition in wind-tunnel force tests corresponds to a constant-speed flight condition for propeller-driven airplanes. Constant-power flight at different airspeeds was simulated in the present wind-tunnel force tests by varying the thrust coefficient with lift coefficient as shown in figure 1. Data obtained at constant thrust (fig. 2(a)) can be used in conjunction with the relations shown in figure 1 to obtain constant-power data indirectly as shown in figure 2(b). Sufficient data are, of course, necessary at different elevator or stabilizer settings so that the stability can be determined for trim conditions. In the case of high-powered single-engine airplanes, the pitching-moment curves for different amounts of thrust are often displaced as shown in figure 2(a) so that at a given lift coefficient the constant-power stability is much less than that measured at constant thrust.

In the flight tests of some airplanes and in the model flight tests reported in reference 2, longitudinal steadiness (the reaction of an airplane to disturbances that cause changes in angle of attack at essentially constant airspeed) seemed to be affected to a much greater extent by changes in constant-thrust stability than by changes in constant-power stability. In airplane flight tests, constant-power longitudinal instability which shows up as a reversal of the variation of stick position and stick force with airspeed is objectionable to the pilot and is considered unsatisfactory on the basis of the present Air Force and Navy flying-qualities requirements (references 3 and 4). This reversal of the variation of stick position and stick force, however, has usually not been as dangerous as the reversal which occurs when the center of gravity is moved behind the maneuver point - the center-of-gravity position for zero maneuver margin. The maneuver margin is directly related to the constant-thrust static margin and is, in fact, identical with the constant-thrust static margin if the damping in pitch of the airplane is neglected.

In order to obtain a verification of these results in a systematic and detailed manner, an investigation has been conducted in the Langley free-flight tunnel with a powered flying model, the static stability of which could be varied over a wide range. Large changes in constant-power stability with lift coefficient were obtained with only small changes in constant-thrust stability by having the thrust axis pass well below the center of gravity. The constant-thrust static margin was varied from 21 to 0 percent of the mean aerodynamic chord and the constant-power static margin was varied from 21 to -15 percent of the mean aerodynamic chord.

SYMBOLS

C_L	lift coefficient (Lift/qS)
C_m	pitching-moment coefficient (Pitching moment/q \bar{c} S)
q	dynamic pressure, pounds per square foot $\left(\frac{1}{2} \rho V^2\right)$
S	wing area, square feet
\bar{c}	mean aerodynamic chord, feet
ρ	mass density of air, slugs per cubic foot
V	airspeed, feet per second
T_C	thrust coefficient (Thrust/qS)
bhp	brake horsepower $\left(\frac{1.65 T_C \rho V^3 D^2}{550 \eta}\right)$
η	propeller efficiency (assumed equal to 0.80)
$-\left(\frac{\partial C_m}{\partial C_L}\right)_{CT}$	constant-thrust static margin
$-\left(\frac{dC_m}{dC_L}\right)_{CP}$	constant-power static margin
δ_e	elevator deflection, degrees
i_t	angle of incidence of tail, degrees
D	propeller diameter, feet
W	weight, pounds

APPARATUS

Tunnel

The investigation was made in the Langley free-flight tunnel which is designed to test free-flying dynamic models. A complete description of the tunnel and its operation is given in reference 5. The force tests to determine the aerodynamic characteristics of the model were made on the six-component balance of the Langley free-flight tunnel, which is described in reference 6.

Model

A three-view drawing of the model is presented as figure 3 and the scaled-up dimensional and mass characteristics are shown in table I. The dimensional and mass characteristics of the model have been scaled up so that the configuration tested represents a $\frac{1}{10}$ -scale model of an airplane of 40-foot span. The power used in the model tests is expressed in terms of full-scale brake horsepower for this airplane in order to afford a better indication of the amount of power simulated.

The model had a pusher propeller with an offset thrust line. The pusher installation was used to minimize any induced slipstream effects and, therefore, obtain a more consistent variation of pitching moment when power was applied. The large offset of the thrust line with reference to the center of gravity was used to produce large changes in pitching moment with the application of power so that greater differences between constant-power and constant-thrust static margin could be obtained. The horizontal tail was located on top of the vertical tail, after preliminary tests with the tail in a low position had shown that a large variation of constant-thrust static margin with lift coefficient existed and that the full effect of thrust on the pitching moment was not realized because inflow to the propeller caused a change in tail load that opposed the moment due to thrust.

Split flaps of 40-percent span were deflected 45° to permit flight tests at higher lift coefficients for which larger differences between constant-power stability and constant-thrust stability could be obtained.

TESTS

Force tests were made with various elevator settings to determine the static longitudinal stability characteristics of the model for the

trim conditions over a range of thrust coefficients from 0 to 0.32. These data were used to obtain the constant-power pitching-moment curves corresponding to a range of full-scale brake horsepower from 0 to approximately 2000. The force tests were made at a dynamic pressure of 4.09 pounds per square foot, which corresponds to a test Reynolds number of approximately 240,000 based on the mean aerodynamic chord of 0.699 foot.

Propeller-on flight tests were made over a range of power setting from 0 to a value of T_c' of 0.32 which corresponds to approximately 2000 full-scale brake horsepower at sea level for a flight lift coefficient of 1.2. Flights were made over the power range with center-of-gravity positions of 34 and 43 percent of the mean aerodynamic chord. Propeller-off flights were made in which the center of gravity was moved back progressively until zero static margin was obtained.

A rating of longitudinal steadiness was assigned by the pilot to each condition tested. One measure of steadiness was the frequency with which elevator deflections had to be applied to keep the model flying smoothly in the center of the tunnel. Another measure of steadiness was the magnitude of vertical motions of the model in the tunnel while the model was being controlled.

RANGE OF VARIABLES

A summary of force-test data showing the variation of constant-thrust and constant-power static margins at a lift coefficient of approximately 1.2 is presented in figure 4. These results were obtained from data similar to those of figure 2. Figure 4(a) shows that the application of full power caused a reduction in constant-thrust static margin of about 4 percent of the mean aerodynamic chord and a reduction in constant-power static margin of about 32 percent of the mean aerodynamic chord. Figure 4(b) shows the variation of constant-thrust and constant-power static margins for the various flight test conditions. With the center of gravity located at 34 percent of the mean aerodynamic chord, application of full power reduced the static margin to -11 percent of the mean aerodynamic chord; whereas with the center of gravity located at 43 percent of the mean aerodynamic chord, slightly less than full power reduced the constant-power static margin to -15 percent of the mean aerodynamic chord.

RESULTS AND DISCUSSION

The longitudinal-steadiness ratings for various flight test conditions are summarized in figure 5. These results show that for a given value of constant-power static margin reducing constant-thrust static margin caused the longitudinal steadiness to become worse and that when the constant-thrust static margin was reduced to zero the flight behavior became very poor. In this condition the model was very difficult to fly and the pilot had to apply elevator control almost continuously to prevent a crash. For a given value of constant-thrust static margin, however, no reduction in longitudinal steadiness was noticeable as the constant-power static margin was reduced. In fact, good flight behavior was obtained even with negative values of constant-power static margin as long as the constant-thrust static margin was adequate. In this condition the model was easy to fly and no tendency toward longitudinal divergence was noted by the pilot despite the large amount of constant-power instability present. These results substantiate previous studies which indicated that the longitudinal steadiness of airplanes is affected to a much greater extent by changes in constant-thrust static margin than by changes in constant-power static margin.

Although the constant-power instability apparently did not influence the longitudinal steadiness in the model flight tests, it is known to appear as reversal of stick position with airspeed which results in a rather slow divergence of the airplane. Flight tests of the model did not indicate any tendency toward divergence, apparently because the initial diverging motion caused by instability was small compared with the relatively large and frequent disturbances from gusts and elevator control movements. The stick-force and stick-position instability which accompany constant-power instability and which are objectionable to the pilot of an airplane were not apparent to the pilot of the model because of the different testing technique; that is, the model was remotely controlled by means of a flicker (full-on or full-off) control. Even though these detrimental effects of constant-power instability could not be observed in the model flight tests it was apparent from the test results that constant-thrust instability produced a much more dangerous condition than that produced by constant-power instability.

CONCLUDING REMARKS

The results of the investigation conducted to determine the dynamic longitudinal stability measured in wind-tunnel force tests under conditions of constant thrust and constant power showed that reductions in constant-thrust static stability caused a decrease in the longitudinal steadiness and that, when the constant-thrust static margin was

reduced to zero, the flight behavior became very poor. For a given value of constant-thrust static margin, however, no reduction in longitudinal steadiness was noticeable as the constant-power static margin was reduced, and even with negative values of constant-power static margin good flight behavior was obtained as long as the constant-thrust static margin was adequate. These results are in agreement with previous studies which indicated that the longitudinal steadiness of airplanes is affected to a much greater extent by changes in constant-thrust static margin than by changes in constant-power static margin.

Langley Aeronautical Laboratory
National Advisory Committee for Aeronautics
Langley Air Force Base, Va., February 3, 1950

REFERENCES

1. Donlan, Charles J.: Some Theoretical Considerations of Longitudinal Stability in Power-On Flight with Special Reference to Wind-Tunnel Testing. NACA ARR, Nov. 1942.
2. Seacord, Charles L., Jr., and Ankenbruck, Herman O.: Determination of the Stability and Control Characteristics of a Straight-Wing, Tailless Fighter-Airplane Model in the Langley Free-Flight Tunnel. NACA ACR L5K05, 1946.
3. Anon.: Flying Qualities of Piloted Airplanes. U.S. Air Force Specification No. 1815-B, June 1, 1948.
4. Anon.: Specification for Stability and Control Characteristics of Airplanes. SR-119A, Bur. Aero., April 7, 1945.
5. Shortal, Joseph A., and Osterhout, Clayton J.: Preliminary Stability and Control Tests in the NACA Free-Flight Wind Tunnel and Correlation with Full-Scale Flight Tests. NACA TN 810, 1941.
6. Shortal, Joseph A., and Draper, John W.: Free-Flight-Tunnel Investigation of the Effect of Fuselage Length and the Aspect Ratio and Size of the Vertical Tail on Lateral Stability and Control. NACA ARR 3D17, 1943.

TABLE I

SCALED-UP DIMENSIONAL AND MASS CHARACTERISTICS

[Model assumed to be 1/10 scale]

Weight, lb	15,400
Wing:	
Area, sq ft	266.67
Span, ft	40.00
Aspect ratio	6.00
Sweepback of 25-percent-chord line, deg	3.2
Incidence, deg	0
Dihedral angle of midthickness line, deg	5
Taper ratio	0.50
M.A.C., ft	7.0
Location of M.A.C. behind L.E. of root chord, ft	1.00
Root chord, ft	9.0
Tip chord, ft	4.49
Wing loading, W/S, lb/sq ft	57.7
Vertical tail:	
Area, to fuselage center line, percent of wing area	13.0
Aspect ratio	0.89
Taper ratio	0.46
Horizontal tail:	
Area, percent of wing area	22.0
Aspect ratio	4.5
Taper ratio	0.59
Center-of-gravity location, ft:	
Vertical, from center line	0
Horizontal, from nose, at -	
34 percent M.A.C.	10.2
43 percent M.A.C.	10.9
Propeller diameter, ft	9.0



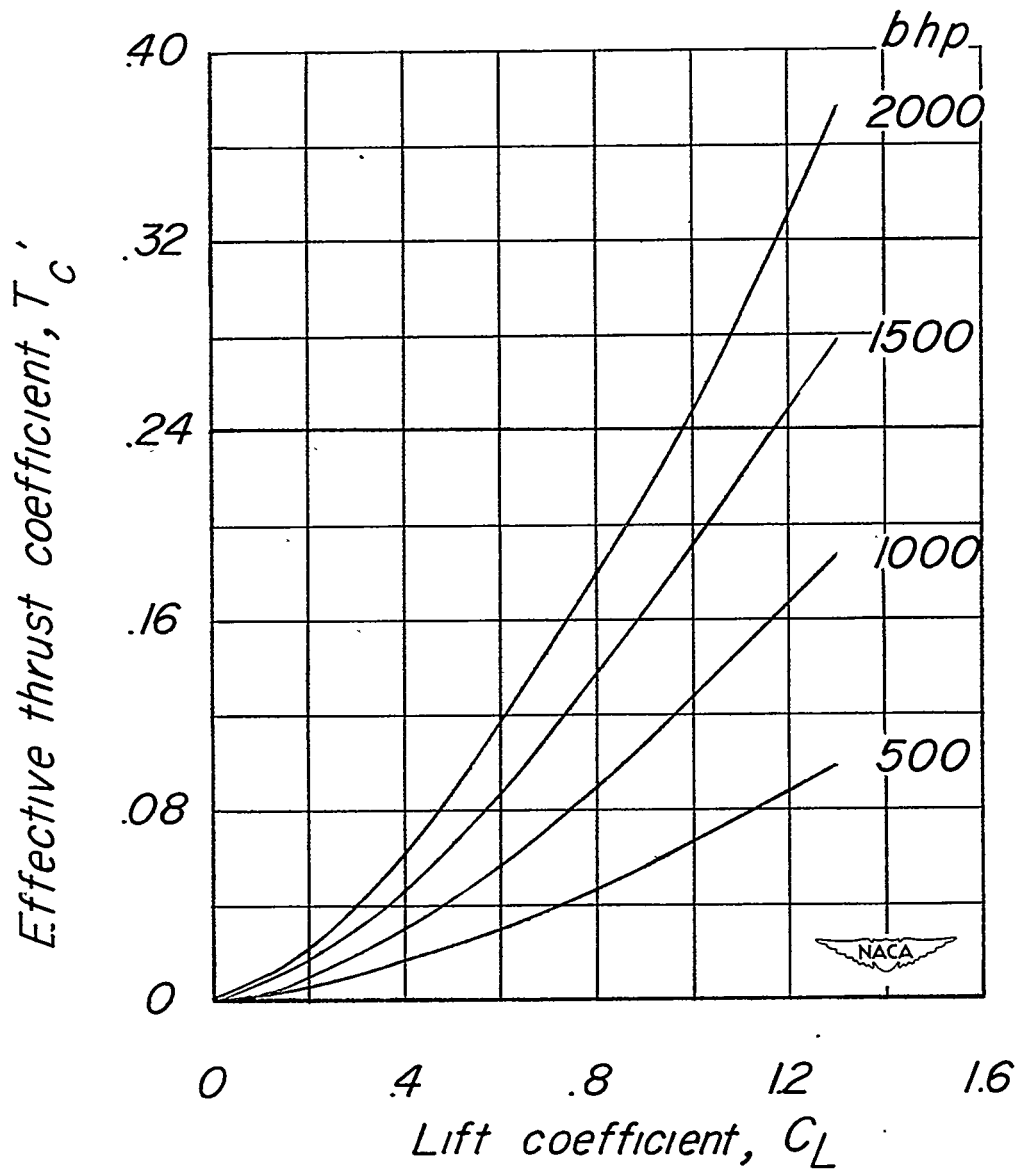

Figure 1.- Variation of thrust coefficient with lift coefficient for various full-scale brake horsepower.

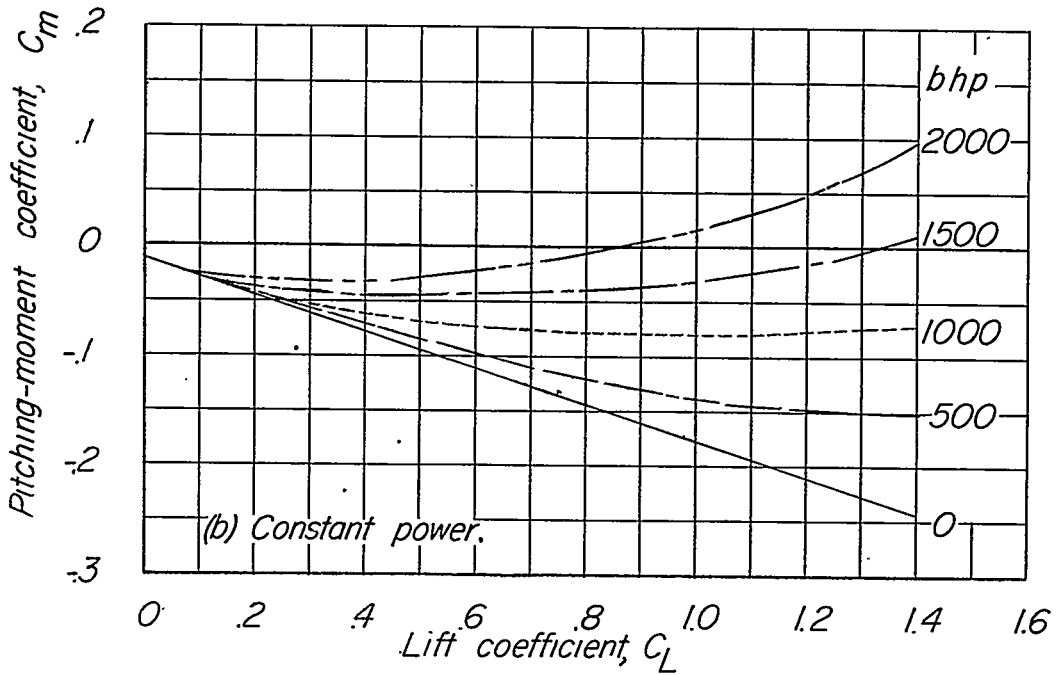
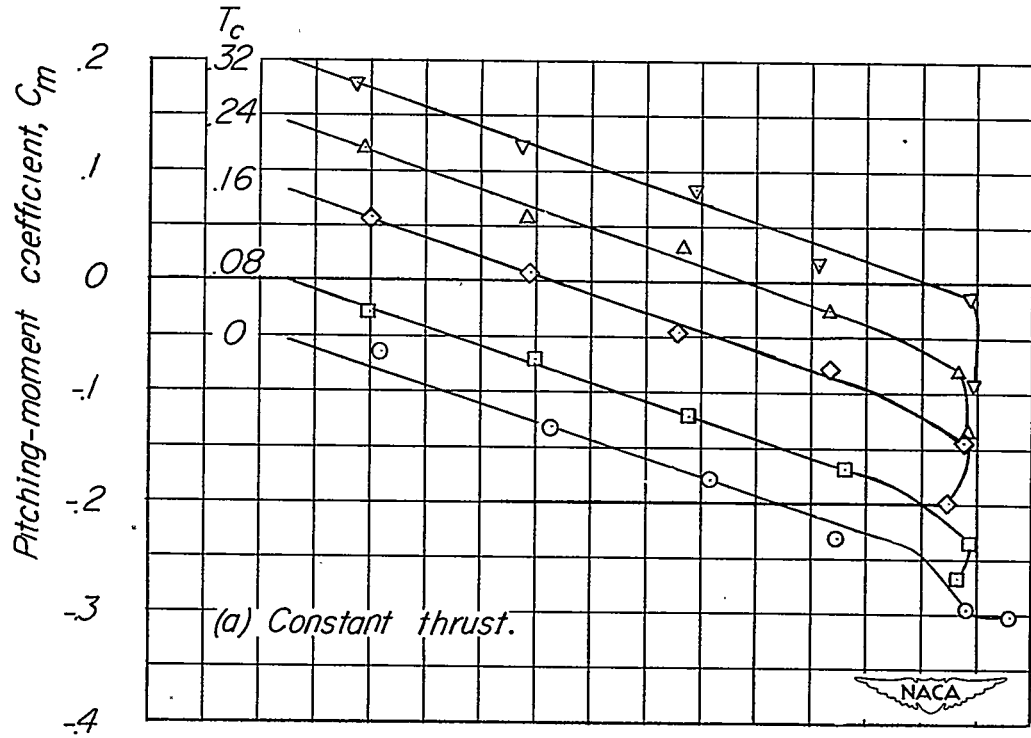

Figure 2.- Representative force-test data; $\delta_e = 0^\circ$; $i_t = 5^\circ$; center-of-gravity location, 34 percent of the mean aerodynamic chord.

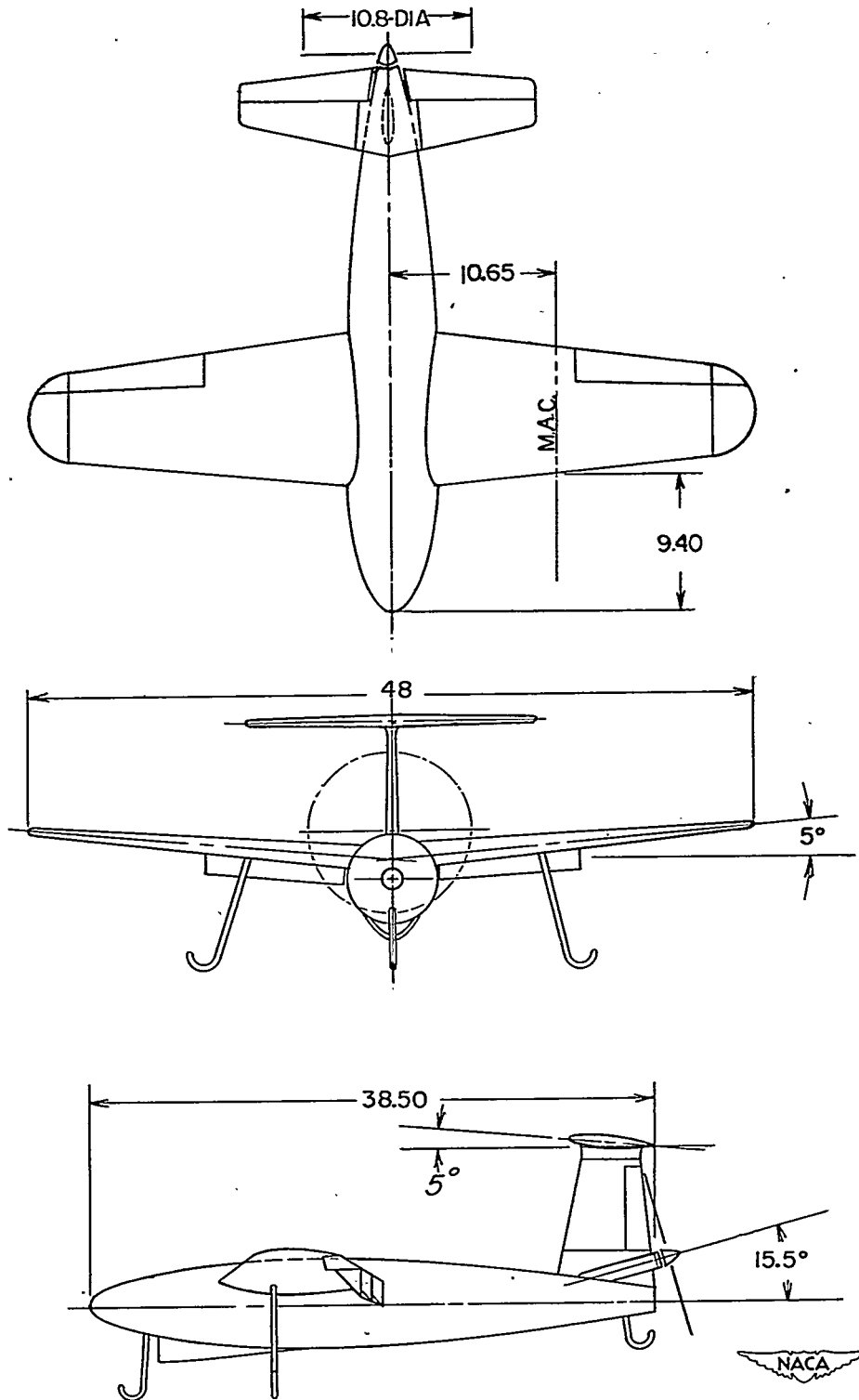
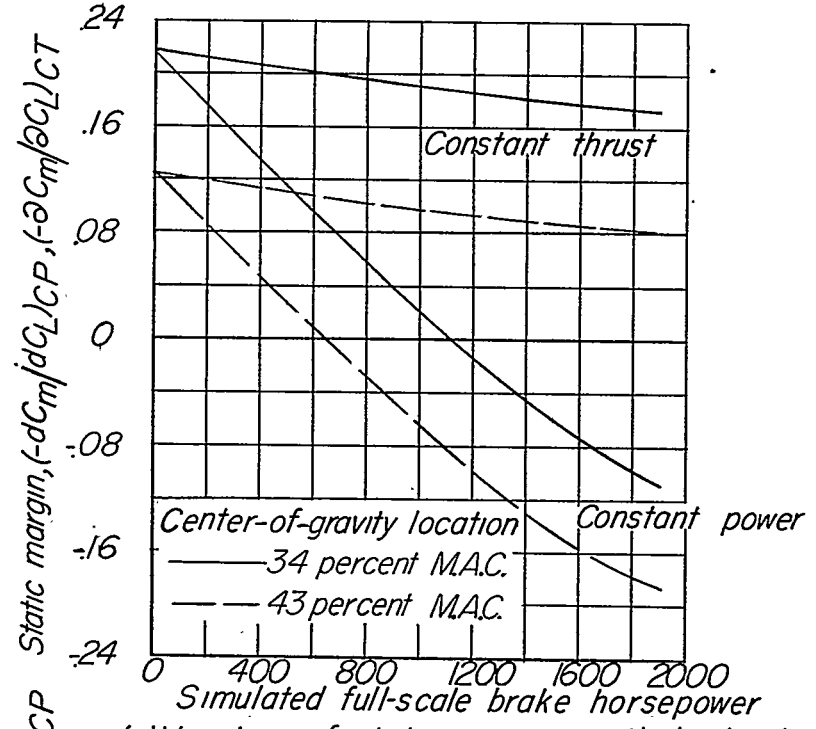
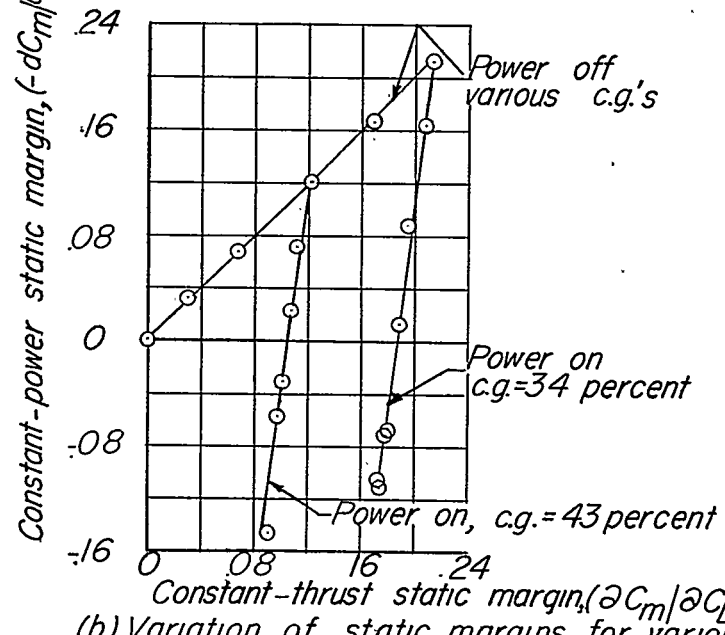

Figure 3.- Model used in longitudinal stability investigation in the Langley free-flight tunnel. All dimensions are in inches.



(a) Variation of static margins with brake horsepower.



(b) Variation of static margins for various flight test conditions.

Figure 4.- Summary of force-test data showing variation of constant-thrust and constant-power static margins covered in model tests; $C_L = 1.2$.



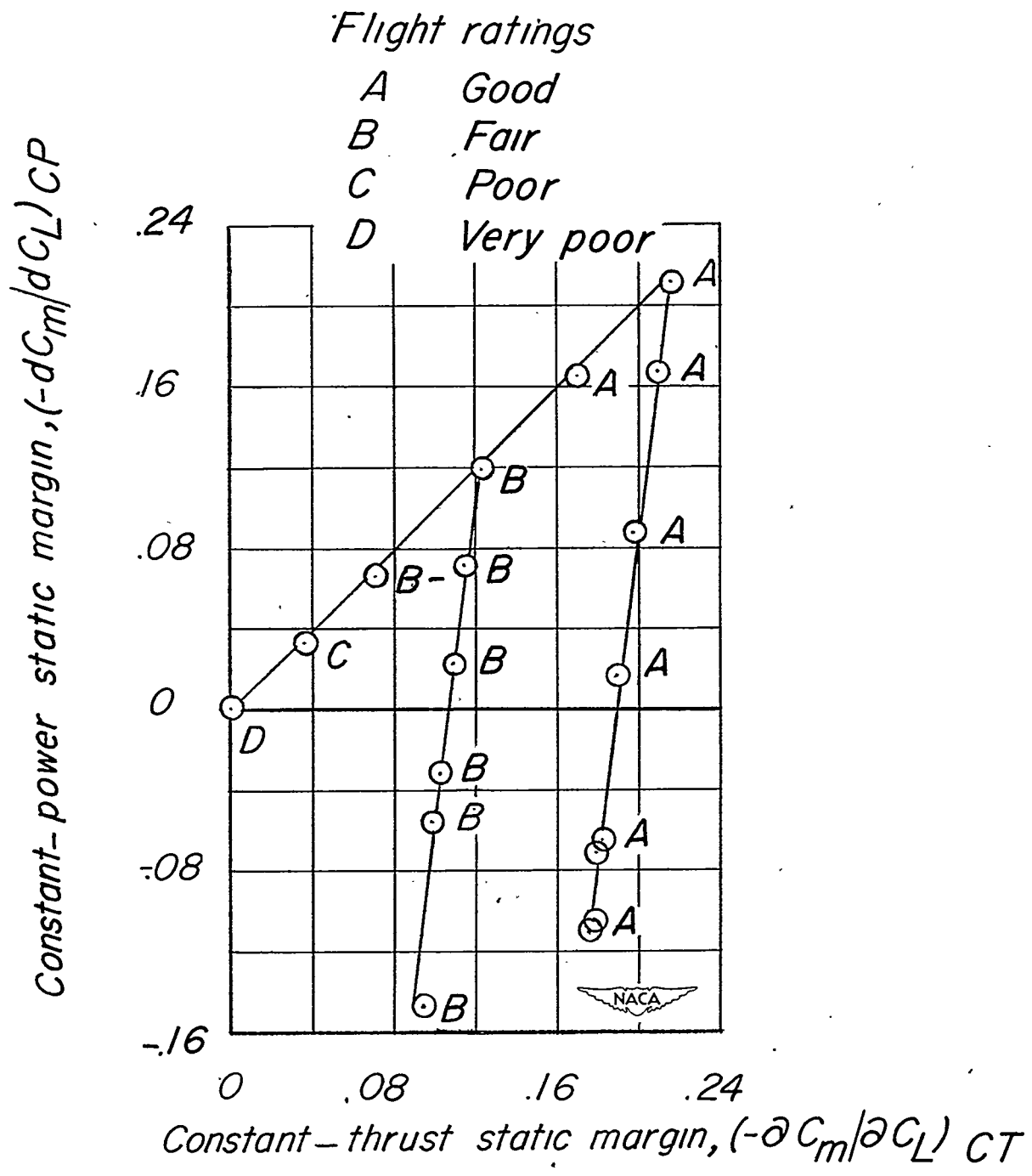

Figure 5.- Longitudinal-steadiness ratings obtained in flight tests of model; $C_L = 1.2$.