

6606
2-28

NACA TN 2730

0065768



TECH LIBRARY KAFB, NM

NATIONAL ADVISORY COMMITTEE FOR AERONAUTICS

TECHNICAL NOTE 2730

CHOKING OF A SUBSONIC INDUCTION TUNNEL BY THE FLOW FROM AN INDUCTION NOZZLE

By W. F. Lindsey

Langley Aeronautical Laboratory
Langley Field, Va.



Washington

July 1952

AFMDC
TECHNICAL LIBRARY
AFL 2811

80523



NATIONAL ADVISORY COMMITTEE FOR AERONAUTICS

TECHNICAL NOTE 2730

CHOKING OF A SUBSONIC INDUCTION TUNNEL BY THE
FLOW FROM AN INDUCTION NOZZLE

By W. F. Lindsey

SUMMARY

A decrease in Mach number with increase in induction-jet pressure has been shown to occur experimentally in one type of induction tunnel at induction-jet pressures in excess of the lowest value required to attain the highest subsonic Mach number. This performance characteristic was analytically demonstrated to be associated with choking of the induced flow by the flow from the induction nozzle. The analysis provides a means of predicting the occurrence of induction choking so that it can be adequately considered in design. Use of an auxiliary induction nozzle operating as a choker is suggested as a means of controlling the speed of a tunnel.

INTRODUCTION

Considerable work has been done both experimentally and analytically toward the development of induction tunnels (refs. 1 to 4). In the previous work, no unusual performance characteristic or reversal of expected performance was reported. Recently, however, during tests to determine the performance of the 24-inch induction tunnel at the Picatinny Arsenal, Ordnance Corps, Dover, N. J., a decrease in stream Mach number was observed to occur as the pressure of the inducing air in the induction nozzle was increased in the high-subsonic speed range. This unusual performance was definitely established as a distinct operational characteristic of the tunnel and it has been analytically studied. The purpose of the present paper is to present the experimental data demonstrating this unusual and undesirable performance and to present an analytical method for predicting its occurrence. This information supplements the material presented on the development and performance of an induction tunnel in reference 3.

SYMBOLS

A	cross-sectional area
a	velocity of sound
f	functional notation
g	acceleration due to gravity
H	total or stagnation pressure
M	Mach number, V/a
p	static pressure
Q	mass flow, ρAV
R	gas constant
T	absolute temperature; static unless otherwise specified
V	velocity
γ	ratio of specific heats (1.4 for air)
ρ	mass density

Subscripts:

1	station at beginning of test section
2	station at end of test section for type I tunnel
3	station at juncture of diffuser and induction-jet nozzle for type I tunnel
4	station at juncture of test section and induction-jet nozzle for type II tunnel
5	station downstream from station 4 where p is constant throughout region
c	station at end of choker jet
j	pertains to inducing flow through induction-jet nozzle

m throat or region of minimum area in induction-jet nozzle
o stagnation conditions
t pertains to induced flow through test section
max maximum

Primed subscripts apply to auxiliary or choker nozzle.

DISCUSSION

General Performance

Two types of induction tunnels that are generally used are shown in figures 1 and 2. The only geometric difference between the two types is in the location of the induction nozzle. In the first arrangement, or type I (fig. 1), the induction nozzle is located in the diffuser downstream of the test section. In the second arrangement, or type II (fig. 2), the induction nozzle is located at the juncture of the test section and the diffuser.

From a simplified analysis based on a transfer of momentum from the inducing air to the induced air, and on the basis of jet-efficiency considerations, type II (fig. 2) offers possibilities of being more efficient than type I (see also ref. 2). Induction tunnels of type I, however, offer definite advantages from a practical aspect where the installation of equipment, such as model support struts, in the air passages has to be considered. Experimental performance data have been obtained on induction tunnels of type I, for which representative data (taken from the investigation reported in ref. 3) are presented in figures 3 and 4.

Figure 3 shows that the Mach number at the test section (between stations 1 and 2) increases with increasing induction-jet stagnation pressure until a value around 1.0 is attained. (The maximum Mach numbers in fig. 3 were somewhat greater than 1.0 because the test-section divergence was greater than the rate of boundary-layer growth, as explained in ref. 3.) Increasing the induction-jet stagnation pressure further causes little or no change in the test-section Mach number, which is the usual aerodynamic choking of a subsonic tunnel due to its geometry.

Inasmuch as this type of tunnel (type I) has a divergent passage between the test section and the induction nozzle, expansion of the flow to even higher Mach numbers in the diffuser between stations 2 and 3 (fig. 1) is possible. The expansions that occur in the diffuser produce Mach numbers in excess of the maximum obtainable in the test

section, as shown in figure 4. The figure shows, for a large range of induction-jet stagnation pressures, that the maximum obtainable Mach number continuously increases with induction-jet pressure. These results (figs. 3 and 4) are in accord with expected performance.

The performance data for an induction tunnel of type II (fig. 2) from tests in the 24-inch high-speed tunnel at the Picatinny Arsenal are shown in figure 5. The data show that the Mach number increases with increase in induction-jet stagnation pressure until a value of 1.0 is approached. Further increases in the jet pressure generally produce decreases in the Mach number in the test section. The data also show that, as the ratio of the test-sectional area to the minimum jet area A_t/A_m increases, the extent of the drop-off in Mach number at the high induction-jet stagnation pressures decreases. From a study of figures 5 and 2, the tunnel performance shown in figure 5 appeared to be a result of a choking effect of the flow from the induction nozzle on the flow through the test section.

The performance data shown in figure 5 were obtained without a model installed in the tunnel. The drag of a model installed in the tunnel would necessarily increase the induction-jet stagnation pressure required to produce a given Mach number and, as indicated by the experimental data of figure 5, choking would occur earlier. In addition, the wake of the model, which consists of a flow area of reduced total pressure, would in effect reduce the area A_t and would produce earlier choking (see fig. 5). These two separate effects of a model in the tunnel on choking are additive; as a consequence, the performance data as shown in figure 5 are conservative, and this type of performance is considered an objectionable performance characteristic.

Analysis

The available analytical work for subsonic tunnels has been limited to induction-jet stagnation pressures below that required to obtain a Mach number of 1.0 in the empty test section. The performance at higher jet pressures is therefore analyzed and presented so that the unusual performance shown in figure 5 for a type II tunnel can be predicted analytically and thus eliminated in the initial design without resorting to experiment.

In the analysis, the following assumptions have been made: (1) At station 5, downstream from station 4 (fig. 2), the static pressure is constant throughout the area A_5 and the area can be considered equal to the total area at station 4; (2) the changes in state in both the induced and inducing flows from their region of low velocity or stagnation conditions to station 5 occur adiabatically, and losses in total pressure can be neglected; and (3) the total pressure in the jet H_j

is sufficiently large that the Mach number of the jet flow through the throat of the induction nozzle M_m is equal to 1.0, and the Mach number of the test flow at station 5 M_{t5} is 1.0. These assumptions require that the static pressure throughout the flow at station 5 correspond to the critical pressure for the test flow (approximately $0.528H_t$).

The mass flow Q through an area A is

$$\begin{aligned}
 Q &= \rho AV \\
 &= \rho A M a \\
 &= \rho_0 \left(\frac{p}{H}\right)^{1/\gamma} A M \sqrt{\gamma R g T} \\
 &= \frac{H}{R g T_0} \left(\frac{p}{H}\right)^{1/\gamma} A M \sqrt{\gamma R g} T_0^{1/2} \left(\frac{p}{H}\right)^{\frac{\gamma-1}{2\gamma}} \\
 &= \sqrt{\frac{\gamma}{R g T_0}} H A M \left(\frac{p}{H}\right)^{\frac{\gamma+1}{2\gamma}} \tag{1}
 \end{aligned}$$

Since the mass flow from the jet through the throat Q_m is equal to the mass flow from the jet at station 5 Q_{j5} , equation (1) gives

$$\begin{aligned}
 \frac{A_{j5}}{A_m} &= \left(\frac{p_m}{H_j}\right)^{\frac{\gamma+1}{2\gamma}} \left(\frac{H_j}{p_{j5}}\right)^{\frac{\gamma+1}{2\gamma}} \frac{1}{M_{j5}} \\
 &= \left(\frac{p_m}{H_j}\right)^{\frac{\gamma+1}{2\gamma}} \left(\frac{H_t}{p_{j5}}\right)^{\frac{\gamma+1}{2\gamma}} \left(\frac{H_j}{H_t}\right)^{\frac{\gamma+1}{2\gamma}} \frac{1}{M_{j5}} \tag{2}
 \end{aligned}$$

Now

$$M^2 = \frac{2}{\gamma - 1} \left[\left(\frac{H}{P} \right)^{\frac{\gamma-1}{\gamma}} - 1 \right]$$

and by assumption

$$\frac{H_t}{P_{j5}} = \frac{H_j}{P_m} = \left(\frac{\gamma + 1}{2} \right)^{\frac{\gamma}{\gamma-1}}$$

Substituting these relations into equation (2) yields

$$\frac{A_{j5}}{A_m} = \left(\frac{H_j}{H_t} \right)^{\frac{\gamma+1}{2\gamma}} \frac{1}{\left\{ \frac{2}{\gamma - 1} \left[\left(\frac{H_t}{P_{j5}} \right)^{\frac{\gamma-1}{\gamma}} \left(\frac{H_j}{H_t} \right)^{\frac{\gamma-1}{\gamma}} - 1 \right] \right\}^{1/2}}$$

$$= \left(\frac{H_j}{H_t} \right)^{\frac{\gamma+1}{2\gamma}} \left[\frac{\gamma - 1}{(\gamma + 1) \left(\frac{H_j}{H_t} \right)^{\frac{\gamma-1}{\gamma}} - 2} \right]^{1/2} \quad (3)$$

The induced flow through the test section Q_t and at station 5 Q_{t5} is treated in a similar manner to obtain

$$\frac{A_t}{A_{t5}} = \left(\frac{p_{t5}}{H_t} \right)^{\frac{\gamma+1}{2\gamma}} \left(\frac{H_t}{p_t} \right)^{\frac{\gamma+1}{2\gamma}} \frac{1}{M_t}$$

$$= \frac{\left(\frac{2}{\gamma+1} + \frac{\gamma-1}{\gamma+1} M_t^2 \right)^{\frac{\gamma+1}{2(\gamma-1)}}}{M_t} \quad (4)$$

By definition,

$$A_5 = A_{j5} + A_{t5}$$

By assumption,

$$A_5 = A_4$$

Hence,

$$\frac{A_4}{A_t} = \frac{A_{j5}}{A_m} \frac{A_m}{A_t} + \frac{A_{t5}}{A_t} \quad (5)$$

Substituting equations (3) and (4) into equation (5) yields

$$\frac{A_4}{A_t} = \frac{A_m}{A_t} \left(\frac{H_j}{H_t} \right)^{\frac{\gamma+1}{2\gamma}} \left[\frac{\gamma-1}{(\gamma+1) \left(\frac{H_j}{H_t} \right)^\gamma - 2} \right]^{1/2} + \frac{M_t}{\left(\frac{2}{\gamma+1} + \frac{\gamma-1}{\gamma+1} M_t^2 \right)^{\frac{\gamma+1}{2(\gamma-1)}}} \quad (6)$$

In order to simplify the discussion, equation (6) can be expressed as

$$\frac{A_4}{A_t} = \frac{A_m}{A_t} f\left(\frac{H_j}{H_t}\right) + f(M_t) \quad (7)$$

For $\gamma = 1.4$, $f\left(\frac{H_j}{H_t}\right)$ and $f(M_t)$ increase with increases in H_j/H_t and M_t , respectively (figs. 6 and 7). The minimum value of H_j/H_t that will satisfy the assumptions in the derivation can be obtained from equation (6) by substituting the corresponding values obtained from the tunnel geometry for A_4 , A_t , and A_m and by letting $M_t = 1.0$ ($f(M_t) = 1.0$ from fig. 7).

In a given induction tunnel, the independent variable in equations (6) and (7) is H_j and the dependent variable is M_t . For some tunnels, where the design of an induction nozzle permits the minimum jet area to be changed, A_m is also a variable. For a given induction tunnel in the present analysis, A_t is a constant. Examination of equation (7) shows that, for a given value of A_m , as H_j is increased above its minimum required value M_t decreases. Similarly, for a given value of H_j , as A_m is increased M_t decreases. These directions of change are in accord with the tunnel performance shown in figure 5 at high jet pressures.

The theoretical performance of the 24-inch high-speed tunnel at the Picatinny Arsenal has been computed by using equation (6); the geometric dimensions of the subject tunnel were used to determine A_4 , A_t , and A_m (H_t was atmospheric pressure and was assumed to be 14.5 lb/sq in. abs). The theoretical performance is compared with experimental performance in figure 8. The very close agreement between theory and experiment shows that the choking effect which produces the objectionable performance characteristic can be predicted analytically and thus can be adequately considered in the design.

Possible Application

This study also indicates the possibility that a secondary induction nozzle could be used to control the velocity of flow through the test section by the choking effect that it can produce. Speed control of an induction tunnel by regulating induction-jet stagnation pressure offers some difficulties as a result of the rate of change of Mach

number with jet pressure (see figs. 3, 4, and 5) and because the supply pressure is decreasing (see ref. 3). In some installations a choking device has been installed downstream of the test section to regulate the Mach number by decreasing the area of the flow. This method provides speed regulation generally through drag or power loss. A choker nozzle, on the other hand, provides speed control through input of energy. This energy input could decrease the power introduced through the standard nozzle. The secondary or choking nozzle would be located between the test section and the main or primary induction nozzle as illustrated for a type I tunnel in figure 9. With the use of the notation in figure 9, equation (7) can be written for the choker as:

$$\frac{A_c}{A_t} = \frac{A_{m1}}{A_t} f\left(\frac{H_{j1}}{H_t}\right) + f(M_t) \quad (8)$$

From equation (8) it can be deduced that the largest range of choked Mach numbers can be attained for a given range of total-pressure ratios when the total area at station c A_c is small and the throat area of the jet A_{m1} is large. The minimum value of A_c occurs when stations c and 2 coincide and the throat of the choker nozzle is at the same station. Variations in A_c can be made by increasing the exit area of the choker nozzle or by moving the choker nozzle downstream from station 2, or a combination of the two. The effects of each of the two changes and combinations of the two have been computed by equation (8) and are presented in figure 10, in which A_c by definition is a variable dependent on A_{m1} .

The computed performance shows that any increase in area at station c causes choking to be delayed to higher jet pressures (compare fig. 10(a) with 10(b) and fig. 10(c) with 10(d)). On the other hand, a downstream shift in station c without changing the choker-nozzle exit area results in an increase in the effect of changes in A_t/A_{m1} (compare fig. 10(a) with 10(c) and fig. 10(b) with 10(d)).

In the determination of the effects of nozzle and nozzle location shown in figure 10, the primary induction nozzle was assumed to be providing sufficient power to induce flow through the test section; however, it is estimated that for the low Mach numbers, which require a relatively large value of A_{m1} and moderately high values of total-pressure ratio, the entire source of power for the tunnel would be derived from the choker nozzle.

CONCLUDING REMARKS

A decrease in Mach number with increase in induction-jet pressure has been shown to occur experimentally in a particular induction tunnel at induction-jet pressures in excess of the lowest value required to attain the highest subsonic Mach number. This performance characteristic was analytically demonstrated to be associated with choking of the induced flow. The analysis also provides a means of predicting the unusual performance characteristic so that it can be adequately considered in design. Use of an auxiliary induction nozzle operating as a choker is suggested as a means of controlling the speed of a tunnel.

Langley Aeronautical Laboratory
National Advisory Committee for Aeronautics
Langley Field, Va., April 7, 1952

REFERENCES

1. Stack, John: The N.A.C.A. High-Speed Wind Tunnel and Tests of Six Propeller Sections. NACA Rep. 463, 1933.
2. Crocco, Luigi: High-Speed Wind Tunnels. Translation No. 366, Materiel Command, U. S. Army Air Corps, July 30, 1943.
3. Lindsey, Walter F., and Chew, William L.: The Development and Performance of Two Small Tunnels Capable of Intermittent Operation at Mach Numbers Between 0.4 and 4.0. NACA TN 2189, 1950.
4. Beavan, J. A., and Holder, D. W.: Recent Developments in High Speed Research. Jour. R.A.S., vol. LIV, Sept. 1950, pp. 545-578.

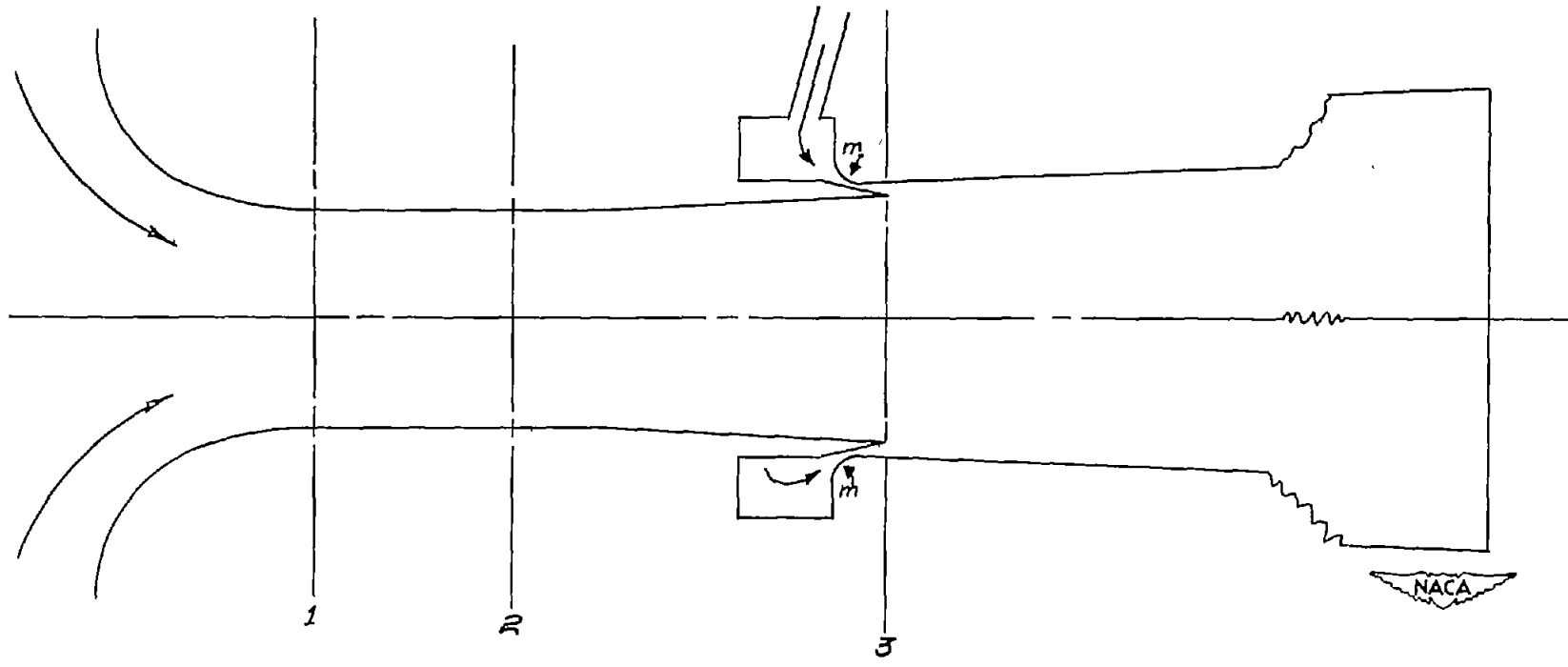

Figure 1.- Type I induction tunnel.

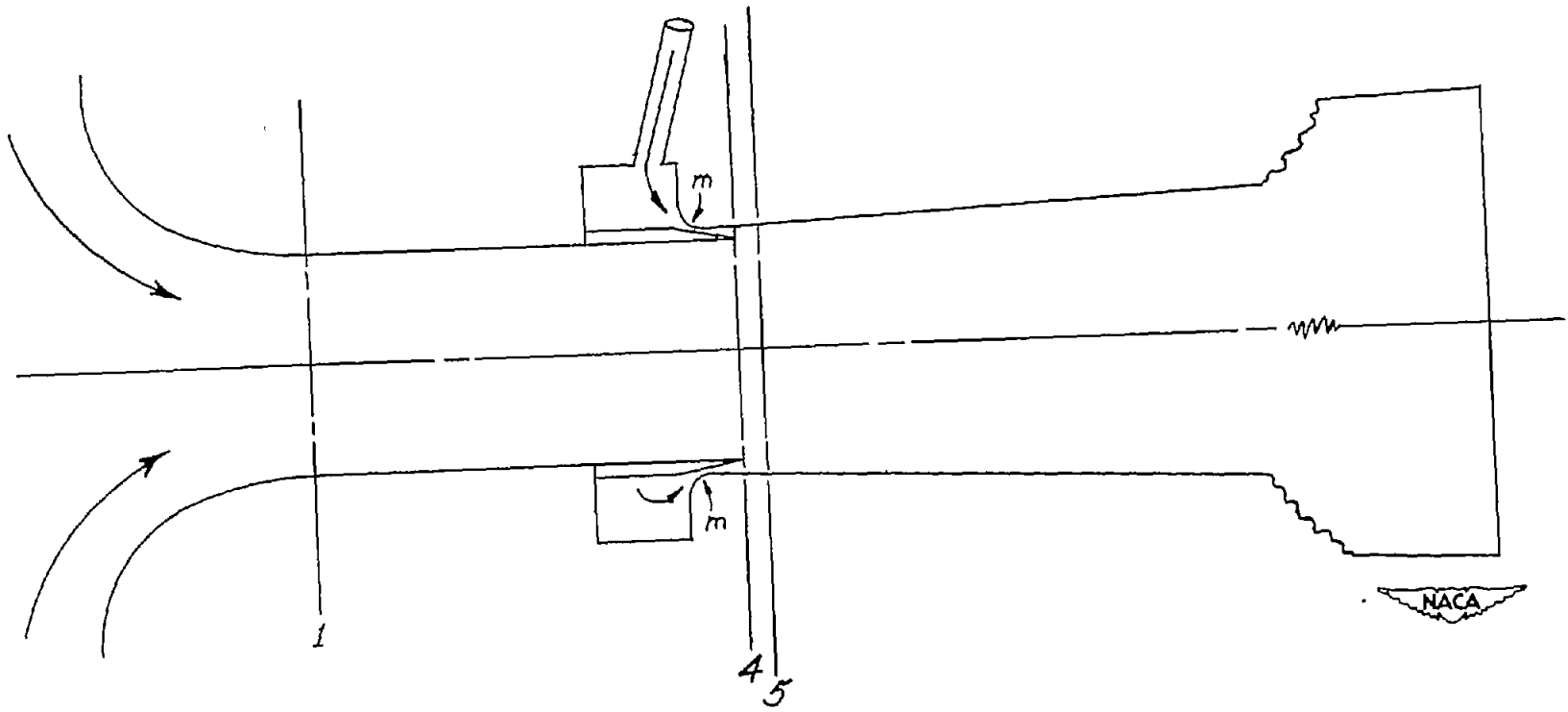

Figure 2.- Type II induction tunnel.

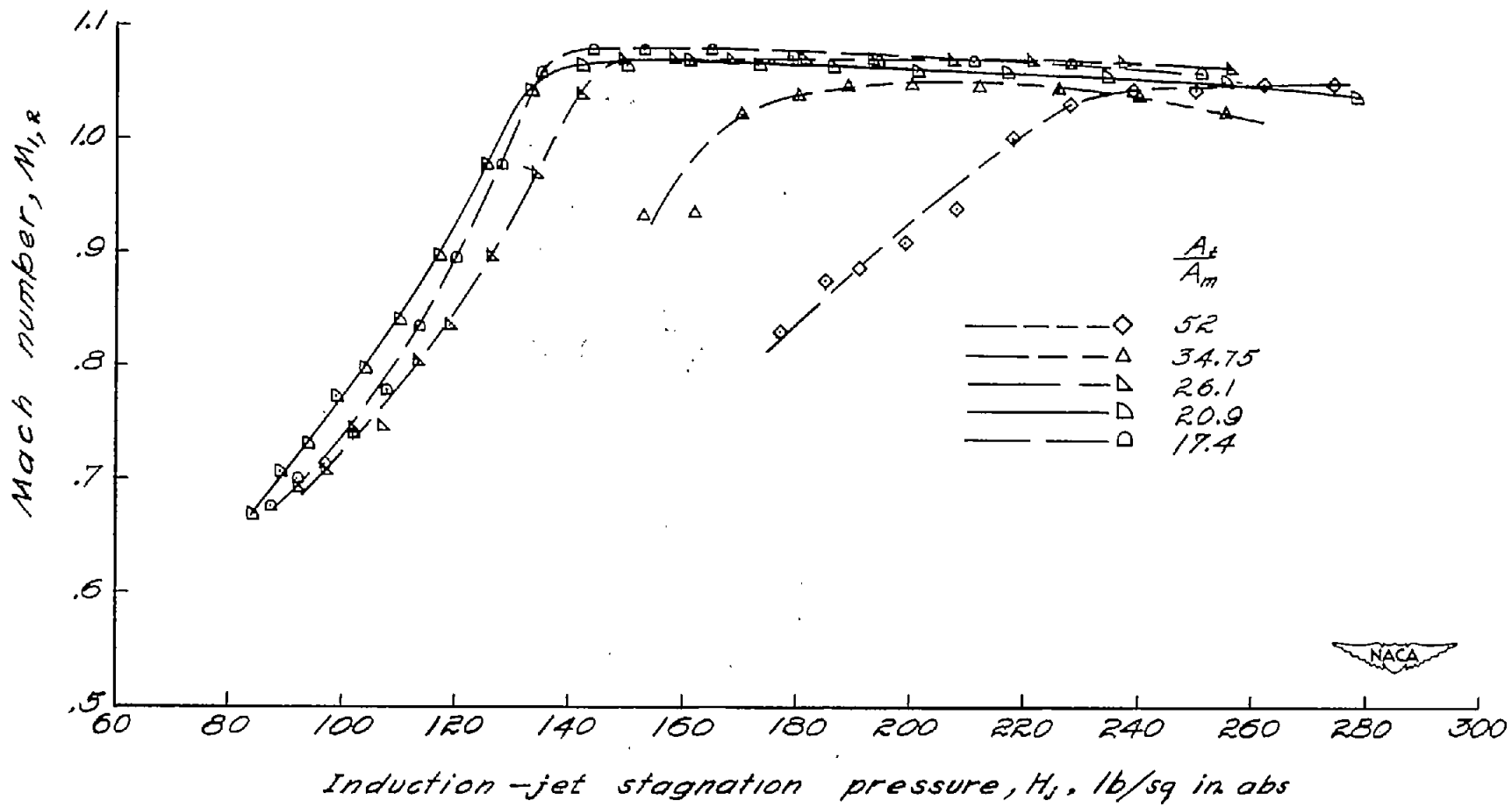

Figure 3.- Performance of type I tunnel based on Mach numbers measured at a station between 1 and 2.



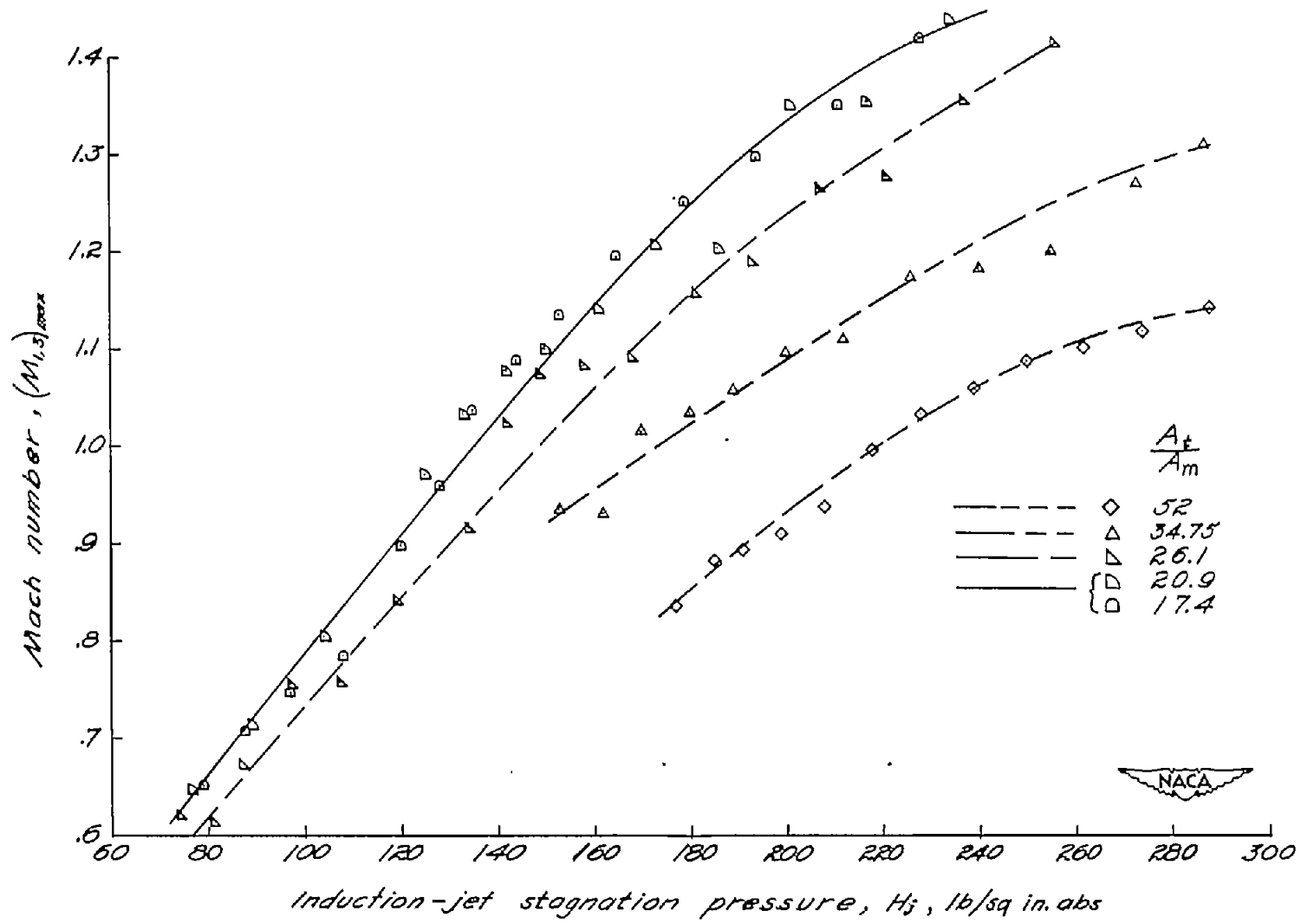

Figure 4.- Performance of type I tunnel based on maximum Mach numbers measured at stations between 1 and 3 (ref. 3).

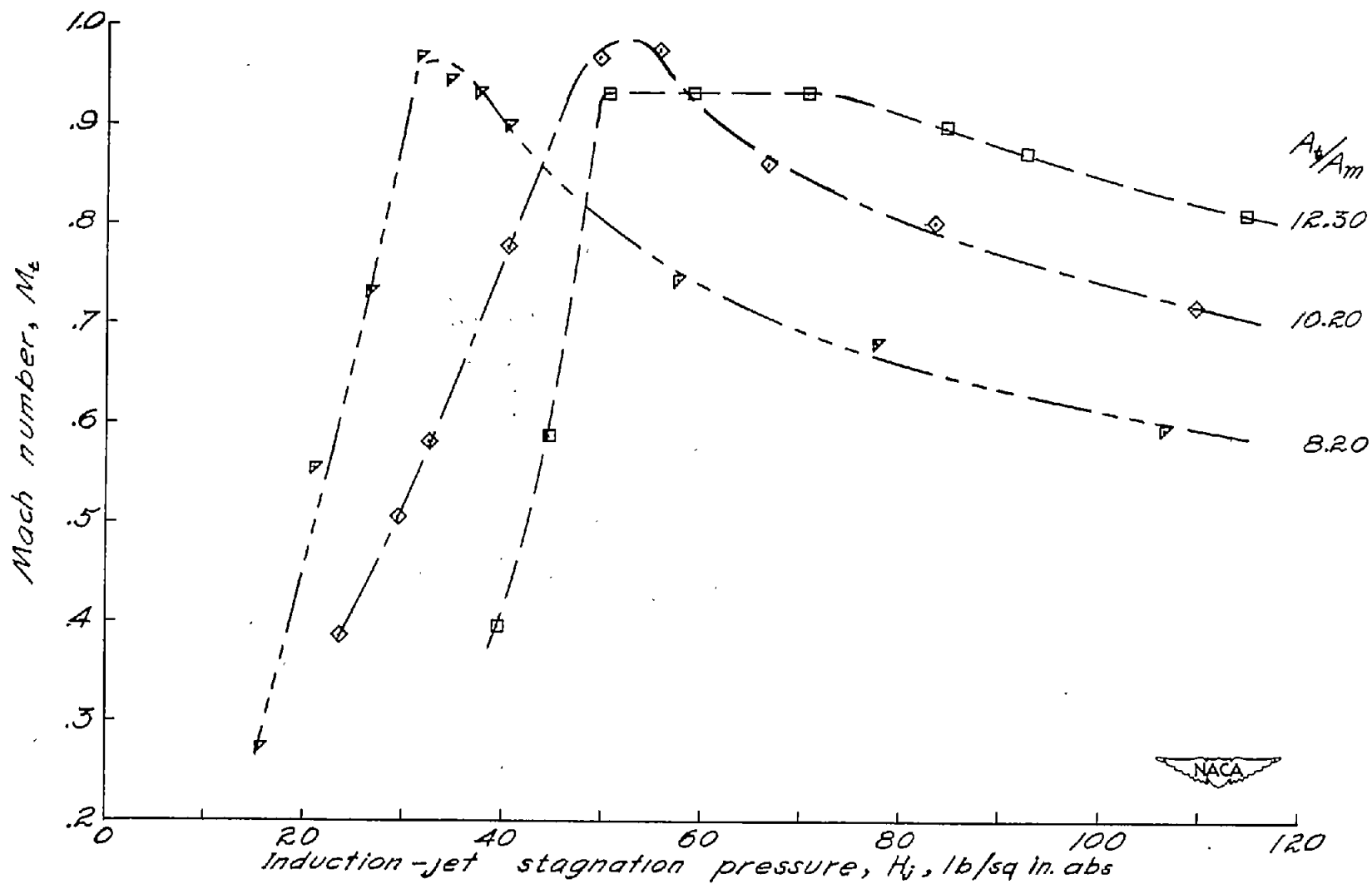

Figure 5.- Performance of type II tunnel.

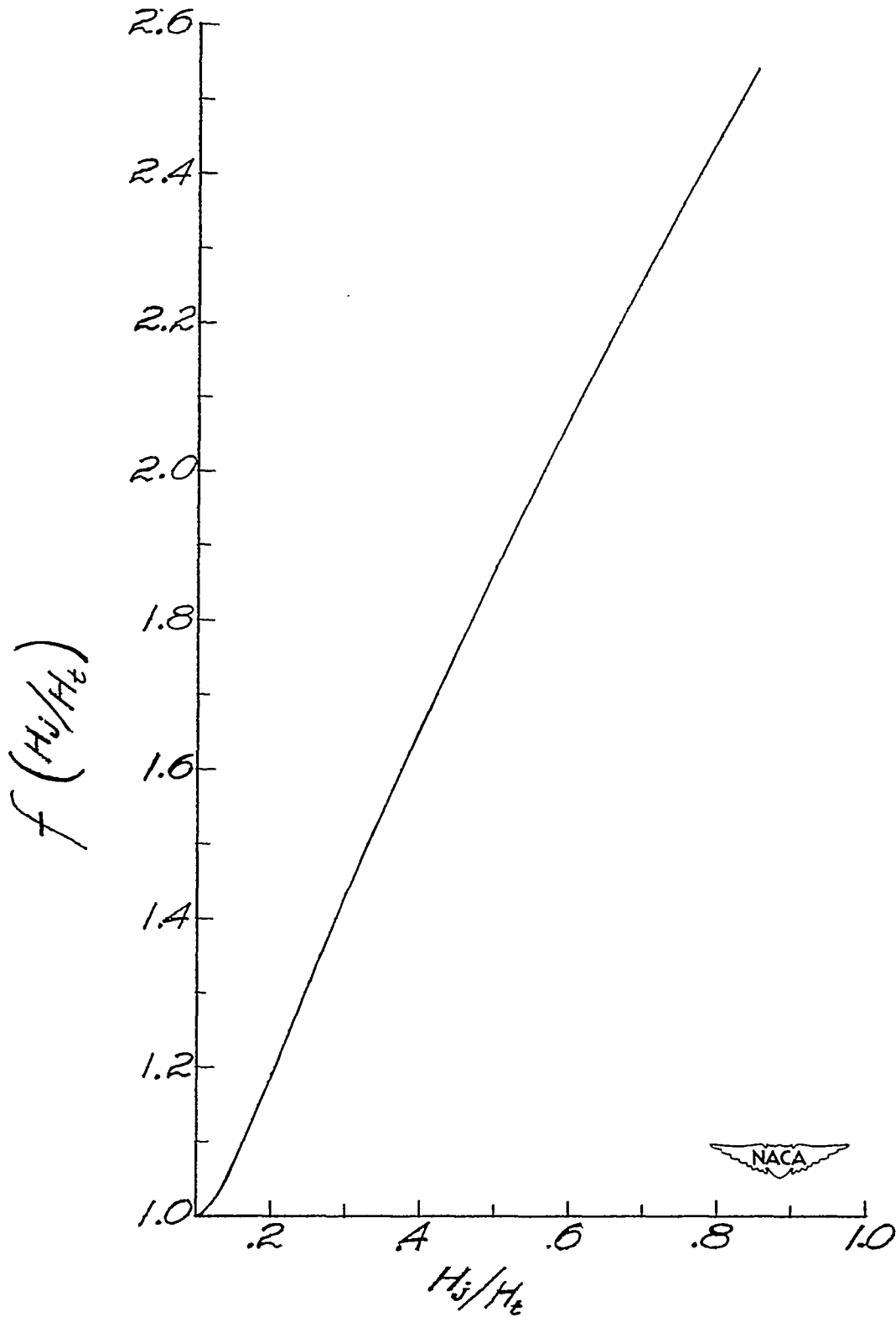

Figure 6.- Variation of total-pressure function with total-pressure ratio.

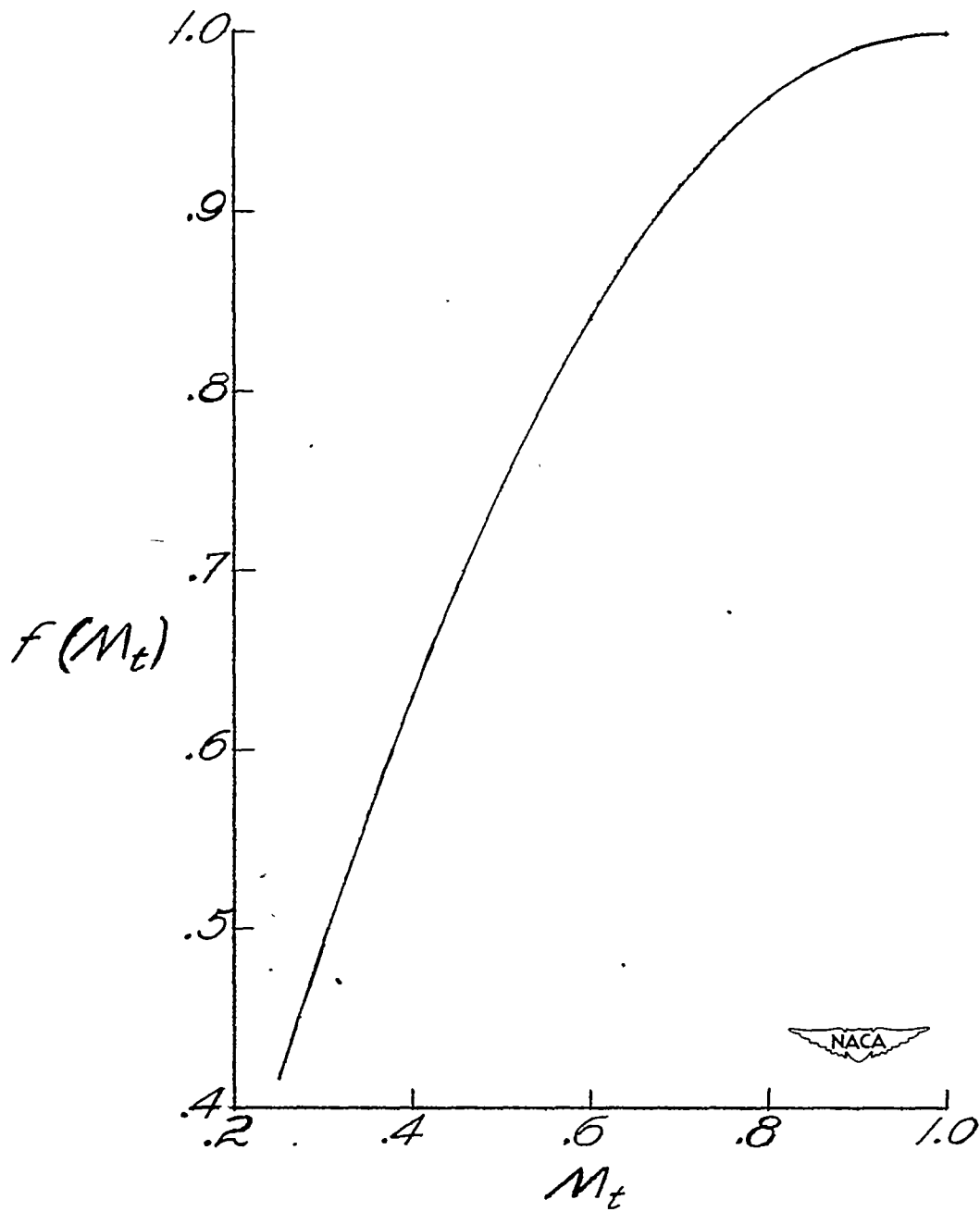

Figure 7.- Variation of Mach number function with Mach number.

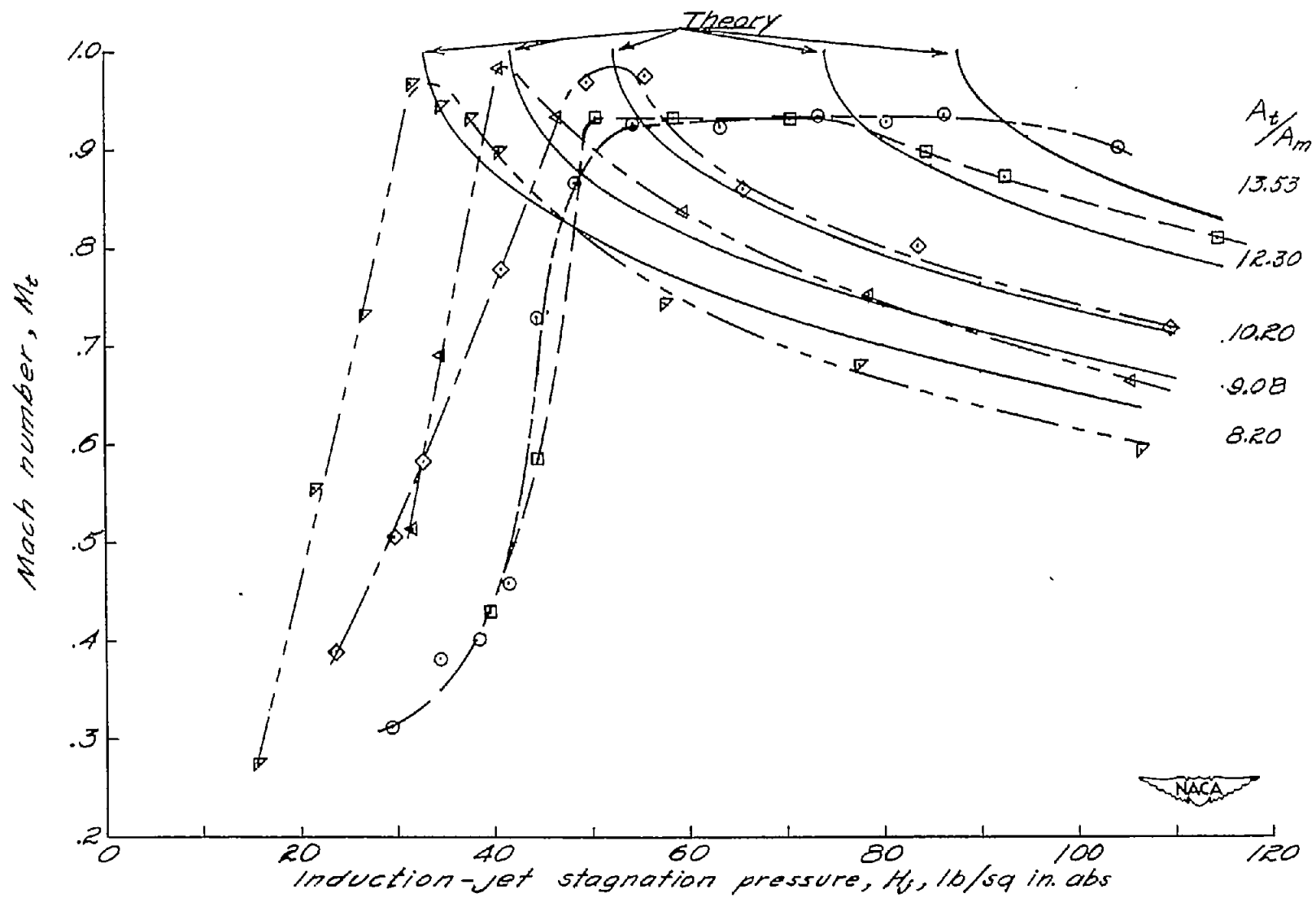

Figure 8.- Comparison of theory and experiment for type II tunnel.

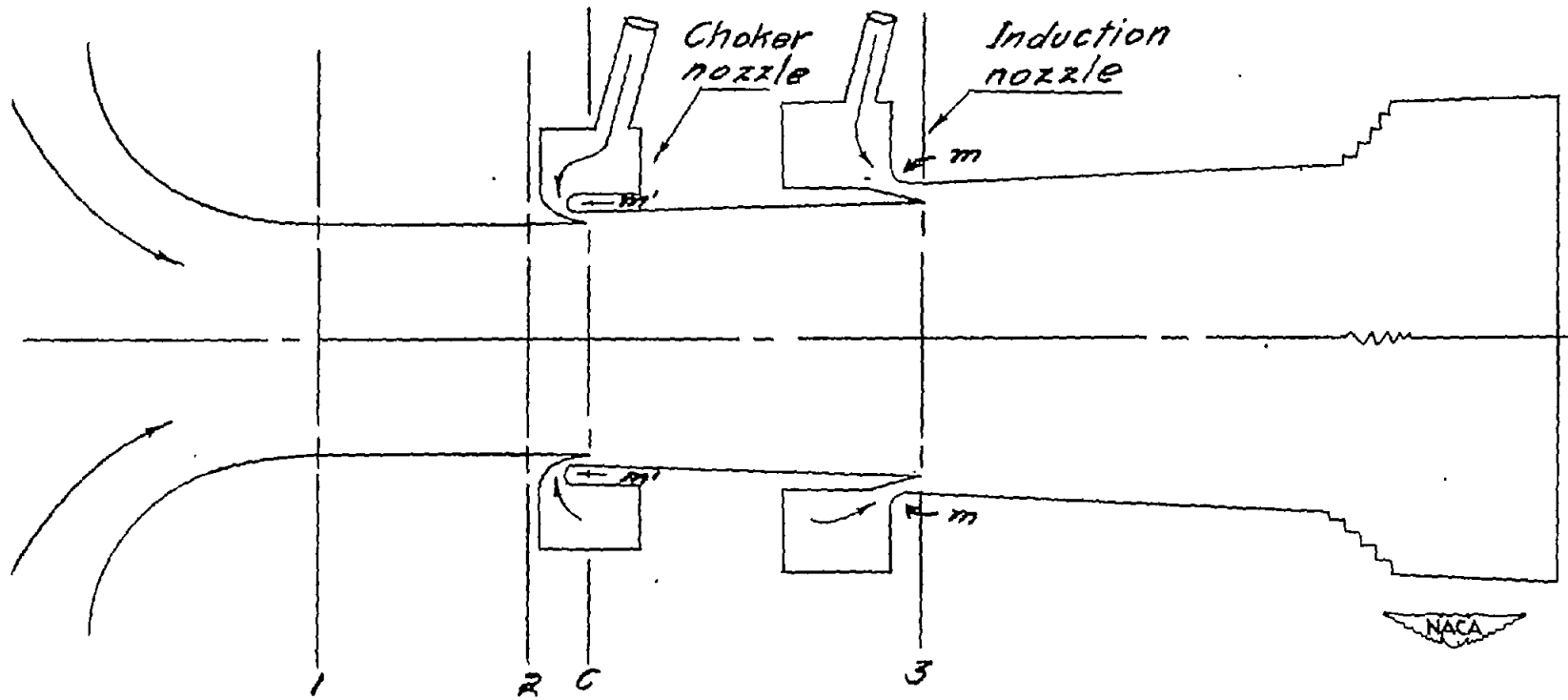
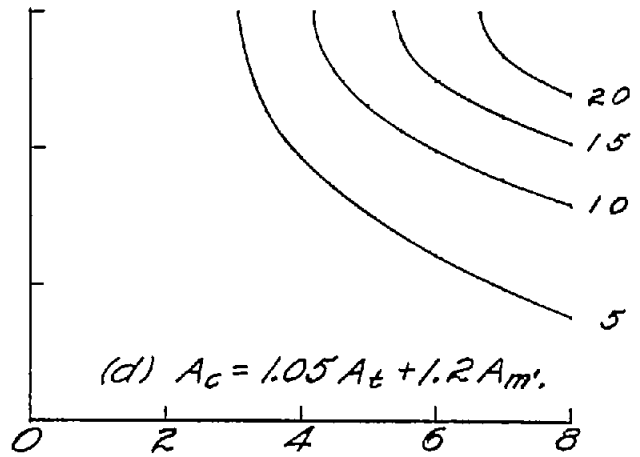
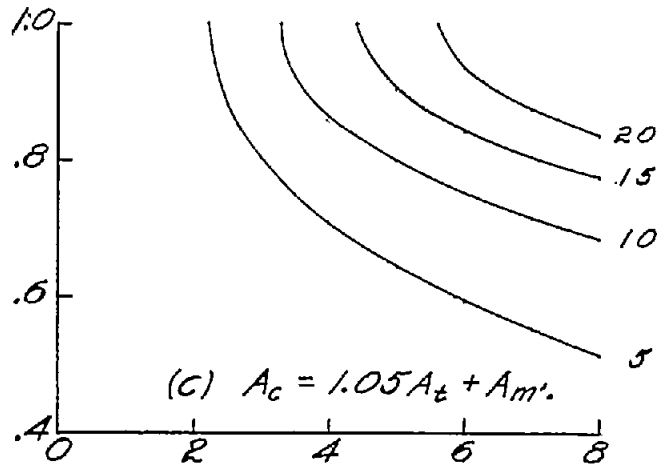
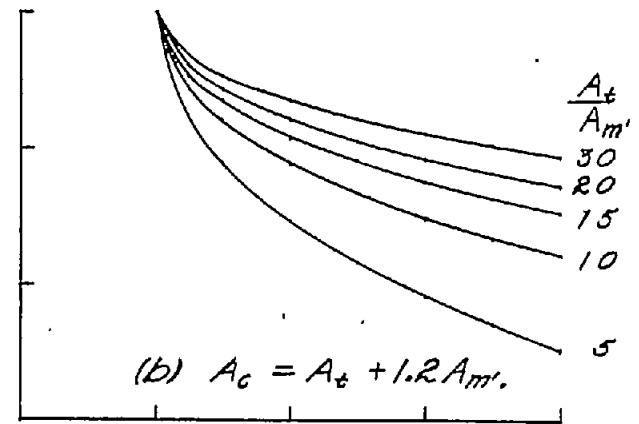
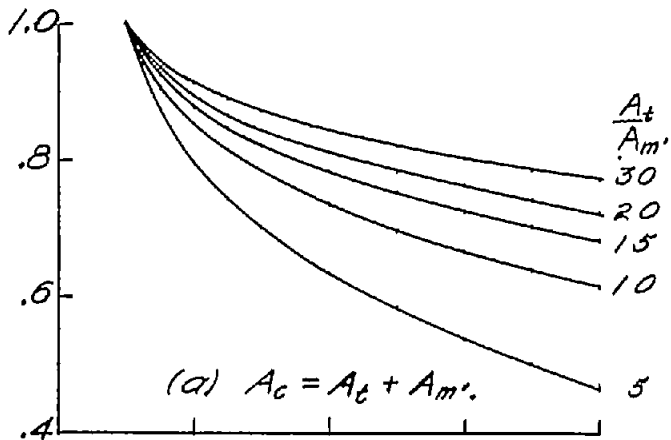

Figure 9.- Type I induction tunnel with jet choker.

Mach number, M_t



Total-pressure ratio, H_3/H_t



Figure 10.- Effects of nozzle and nozzle location on choking.

NACA-Tangler - 7-8-53 - 1000