

9602

NACA TN 3310

TECH LIBRARY KAFB, NM
0066307

NATIONAL ADVISORY COMMITTEE FOR AERONAUTICS

TECHNICAL NOTE 3310

INVESTIGATION OF STATIC STRENGTH AND CREEP BEHAVIOR
OF AN ALUMINUM-ALLOY MULTIWEB BOX BEAM
AT ELEVATED TEMPERATURES

By Eldon E. Mathauser

Langley Aeronautical Laboratory
Langley Field, Va.



Washington
November 1954

AFMDC
TECHNICAL LIBRARY
AFL 2811



0066307

NATIONAL ADVISORY COMMITTEE FOR AERONAUTICS

TECHNICAL NOTE 3310

INVESTIGATION OF STATIC STRENGTH AND CREEP BEHAVIOR

OF AN ALUMINUM-ALLOY MULTIWEB BOX BEAM

AT ELEVATED TEMPERATURES

By Eldon E. Mathauser

SUMMARY

The results of an investigation to determine the static strength and creep behavior at elevated temperatures of seven nominally identical multiweb box beams made of 24S-T3 aluminum alloy are presented. The methods that were used to predict failure stresses in the static-strength tests were in good agreement with the experimental results. Creep deflections and creep lifetimes are presented for beams subjected to constant loads and to various heating conditions. Lifetime is satisfactorily predicted from material stress-rupture data when tensile failure occurs at both constant or varying temperatures.

INTRODUCTION

Determination of static strength and creep behavior of fabricated structures subjected to elevated temperatures is a problem of importance in the design of aircraft. Room-temperature static strength of fabricated structures such as box beams can be estimated from methods of the type outlined in reference 1. Although these methods may be used to estimate elevated-temperature static strength of box beams, the results have not been verified experimentally.

At present, no methods are available for predicting creep behavior of fabricated structures. Studies have been made to obtain procedures for determining creep behavior of structural components such as columns, stiffened panels, and solid-section beams (for example, refs. 2 to 4); however, extension of these procedures for application to box beams has not been made. The prediction of creep behavior of fabricated structures is a complex problem for which approximate or empirical solutions may be most practical. In any case, the prediction of creep behavior should be guided and confirmed by experimental data.

In the present paper, a study is made of the results obtained from static-strength and creep tests at room temperature and elevated temperatures of seven nominally identical multiweb box beams of 24S-T3 aluminum alloy. Static strengths are determined from procedures given in references 1, 5, and 6 and are compared with the experimental data. Tensile and compressive failures of the box beams are predicted in the static-strength tests for different temperatures and different exposure times. For tensile failure in the creep tests, the lifetimes for beams subjected to constant load and either constant or varying temperatures are predicted from tensile creep data presented with the use of a time-temperature parameter (ref. 7).

TEST SPECIMENS, EQUIPMENT, AND PROCEDURES

The seven nominally identical box beams fabricated for this investigation were tapered multiweb beams. The beam dimensions, the location of the supports, and the points of application of loads are indicated in figure 1. Figure 2 shows a cross section of the box beams. The beams were made of 24S-T3 aluminum-alloy sheet, except that 75S-T6 aluminum-alloy angles were selected because of availability. The angles were used to join the webs and cover plates and were also used as upright stiffeners on the webs at the supports and at the points of application of the loads. The dimensions and material thicknesses of the seven box beams fabricated for the static-strength and creep tests are shown in table I. Both cover plates of the box beams were of equal thickness. The buckling stress of the compression cover plate at room temperature for this beam design was approximately equal to the compressive yield stress of the material. For this beam design, failure at room temperature was expected to result from inelastic buckling of the compression cover.

The beams were tested at elevated temperatures in a furnace. In figure 3, the furnace is shown in a raised position to expose the test beam. Additional equipment shown includes the power control panel, the temperature recorder, the load-deflection recorder, and the control panel for the hydraulic loading apparatus. Hydraulic jacks were used to apply tip loads on the specimens in the static-strength tests. Weight cages were substituted for the hydraulic jacks in the creep tests to obtain constant loads. The temperature of each specimen at several stations along the beam was obtained by using iron-constantan thermocouples. During the tests, the specimen temperature was controlled within approximately $\pm 2\frac{1}{2}^{\circ}$ F of the desired temperature. In the creep tests, deflections were measured by using small-diameter steel wires to transfer the creep deflections of the beam to gages mounted outside the furnace.

In the static-strength tests, the beams were heated to the test temperature, exposed to test temperature for a selected period of time, and then tip loads were applied hydraulically at a uniform rate. Maximum load was attained in about 15 minutes. Loading of the weight cages and heating of the beams began simultaneously in the creep tests. Approximately 15 minutes were required to load the weight cages. The furnace reached the test temperature in 15 minutes; however, an additional 45 minutes was required to stabilize the beams to the test temperature. Failure time was measured from the beginning of heating.

RESULTS AND DISCUSSION

Static-Strength Tests

Test results.- Three box beams were tested to determine static strength at room temperature, at 370° F with $\frac{1}{2}$ -hour exposure, and at 425° F with 2-hour exposure. The results of these tests are summarized in table II. Compressive failure of the beams occurred at room temperature and at 370° F; tensile failure occurred at 425° F. Examples of these failures are shown in figure 4.

Failure stresses associated with the maximum test loads are shown in table II. These stresses were calculated by assuming that a fully plastic rectangular stress distribution was produced on the beam cross section where failure occurred when the maximum experimental loads were applied. The net section of the tensile cover plate was used in the calculations.

Analysis for type of failure and prediction of static strength.- The magnitude of the stress that will produce failure of the tension cover plate is determined from the ultimate tensile strength of the material. The ultimate tensile strengths of the box-beam cover-plate material obtained for temperatures and exposure times corresponding to the test conditions are shown in figure 5. These data supplemented with data from reference 8, as well as the failure stresses associated with the maximum test loads of beams 1 to 3, are plotted in figure 6 for the two exposure times.

Compressive stresses that will produce failure of the cover plate can be determined from equation (6) of reference 1. These stresses are also plotted in figure 6. The rivet clamping distance of this beam cross section is required to calculate the magnitude of the maximum compressive stress for the cover plate and is assumed to be the distance from the web plane to the near edge of the shanks of the rivets which attach the webs to the cover plates. The plasticity

coefficient η used in equation (6) of reference 1 was evaluated from compressive stress-strain data in figure 5 of the present report and from data of reference 9.

Compressive failure of the beam is predicted from figure 6 for all temperatures except in the range from 370° F to 480° F for 2-hour exposure in which tensile failure is predicted. The test results agree with these predictions. Since the magnitude and the type of failure stress are predicted, the maximum tip loads can be calculated. If a fully plastic rectangular stress distribution is assumed on the beam cross section at failure, tip loads associated with these predicted failure stresses will be obtained as shown in table II. Good agreement between the predicted loads and experimental loads is obtained. If stress distributions of the type given in references 5 and 6 are assumed, substantially the same maximum tip loads will be obtained. For these calculations, it was assumed that the stress-strain properties of the 75S-T6 aluminum-alloy angles are identical to the properties obtained from the material used in the 24S-T3 aluminum-alloy box beams shown in figure 5.

Creep Tests

Test conditions and experimental results.- Four box beams were tested to determine creep behavior under several test conditions. The conditions and results of the tests are summarized in table III. Creep deflections were obtained along the longitudinal center line of the beam at the stations indicated in figure 7(a).

Beam 4 and beam 5 were tested at constant temperatures of 375° F and 425° F, respectively, until failure resulted. Beam 4 was subjected to a tip load of 5,400 pounds, and beam 5 was loaded at the tip with 3,750 pounds. Creep deflections obtained in these tests are given in figures 7(b) and 7(c). Failure occurred in each test by rupture of the tension cover plate.

Beam 6 was subjected to constant load and was heated intermittently. After an initial heating period of approximately 38 hours at 425° F, the beam was cooled to room temperature. The specimen was then subjected to temperature cycles of approximately 8 hours at 425° F and of approximately 16 hours at room temperature until failure occurred. The periods at room temperature indicated by the discontinuities in the curves have been omitted in the deflection-time history shown in figure 7(d). The load remained on the specimen until failure occurred. Failure in this beam occurred by buckling of the compression cover plate.

Beam 7 was subjected to a constant tip load at various test temperatures with intermittent heating. The creep deflections at station 1

and the temperature history are shown in figure 7(e). Periods of approximately 16 hours during which the specimen was cooled to room temperature have been omitted in the figure. The load was maintained on the specimen until failure occurred by tensile rupture.

The tensile and compressive failures in the creep tests resembled the failures shown in figure 4. However, evidence of local yielding, or plastic flow of the tension cover plates near the rivets at the beam center section, was observed at the completion of the tests. Local yielding resulting from stress concentrations was not visible in the static-strength tests.

The deflection-time curves of figure 7 show that the beams failed soon after the beginning of accelerated deflection, and that little additional deflection was obtained from the beginning of accelerated deflection to the time of collapse. This behavior suggests that the deflection-time history of box beams may give little warning to indicate when collapse is imminent.

Determination of creep deflections.- An attempt was made to calculate creep deflections by using tensile creep data given in references 10 to 13. The calculated deflections, in general, were substantially less than the experimental values. In part, this disagreement was probably due to the use of tensile creep data that were not representative of the box-beam material and of test conditions for the beams. Also, shear and bearing distortions at the riveted connections were neglected in the calculations. Distortions were noticeable around the rivets and may have produced a significant increase in the creep deflections. At present, no method is available for predicting these effects on creep deflections.

Prediction of lifetime for constant load and constant temperature.- Tensile stress-rupture data are used in the present report for predicting tensile rupture time for beams subjected to constant load and constant temperature. A master rupture curve for 24S-T3 aluminum alloy is obtained by plotting tensile stress-rupture data (refs. 10 to 13) in terms of the parameters given in reference 7. These parameters (shown in fig. 8) are stress and $T_R(17 + \log t)$, where T_R is temperature in degrees Rankine, t is rupture time in hours, and 17 is a material constant evaluated for 24S-T3 aluminum alloy in reference 14.

The results of the present box-beam creep tests are shown in figure 8 in terms of maximum bending stresses, temperatures, and failure times from table III. The predicted failure times for the beams, obtained from the master rupture curve, are given in tables III and IV. Satisfactory agreement between the predicted and experimental lifetimes is obtained for tensile failures.

Beam 6, intermittently heated at 425° F, failed by buckling in approximately 80 percent of the time predicted for tensile failure. This beam was subjected to a smaller tip load than beam 5 (tested at a constant temperature of 425° F) for which tensile failure occurred. No criterion has been established for predicting the occurrence of compressive failure in the box beams from the limited test data. The master rupture curve does, however, establish the approximate upper limit for lifetime of these beams.

Prediction of lifetime at constant load and varying temperatures.- The lifetime of box beam 7 was predicted by assuming that figure 8 could be used to determine rupture time for a specimen subjected to constant stress and varying test temperatures. Beam 7 was subjected to a bending stress of 30.0 ksi and to several temperatures for periods shown in figure 7(e). These periods at each temperature include the 1 hour required to heat and to stabilize the specimen at test temperature but do not include the time during which the specimen was cooled to room temperature.

In this report, it is assumed that the heating and the cooling periods may be reduced to equivalent time at test temperature by means of the relation (see ref. 7)

$$T_1(17 + \log t_1) = T_2(17 + \log t_2) \quad (1)$$

where T_1 and T_2 represent different test temperatures in degrees Rankine, and t_1 and t_2 represent time at the respective test temperatures. The time-temperature history of the heating and the cooling periods of the beam was divided into small time increments, and the previous relation (eq. (1)) was used to reduce the time increments to corresponding time increments at test temperature. These computations indicated that each heating and each cooling period corresponded to approximately 0.60 hour and 0.25 hour, respectively, at test temperature. The time at each test temperature shown in table IV includes these adjustments for the heating and the cooling periods. The beam lifetime predicted from figure 8 for each test temperature and the percentage of the predicted lifetime exhausted at each test temperature are also given in this table. The total of the percentages in column (4) of table IV indicates that the lifetime predicted in this manner is approximately 5 percent less than the experimental lifetime. The accuracy of the lifetime predicted for this case compares favorably with the accuracy of the lifetime predicted for tensile failure for constant test temperatures in table III.

CONCLUDING REMARKS

Both tensile and compressive failures occurred in the static-strength and creep tests of seven nominally identical multiweb box beams of 24S-T3 aluminum alloy at different loads, temperatures, and exposure conditions. In the static-strength tests, the type of failure was predicted accurately, and the failing or maximum loads were determined satisfactorily from methods given in the literature. Tensile failure time in the creep tests was predicted satisfactorily for these particular box beams when subjected to constant load and either constant or varying temperatures. Tensile creep data plotted in the form of stress against a time-temperature parameter were used for prediction of the lifetime of the box beams. No methods were found that satisfactorily predicted creep deflections or creep buckling failure.

Langley Aeronautical Laboratory,
National Advisory Committee for Aeronautics,
Langley Field, Va., August 23, 1954.

REFERENCES

1. Semonian, Joseph W., and Anderson, Roger A.: An Analysis of the Stability and Ultimate Bending Strength of Multiweb Beams With Formed-Channel Webs. NACA TN 3232, 1954.
2. Mathauser, Eldon E., and Libove, Charles: Preliminary Investigations of Strength Characteristics of Structural Elements at Elevated Temperatures. NACA RM L53E04a, 1953.
3. Mathauser, Eldon E., and Brooks, William A., Jr.: An Investigation of the Creep Lifetime of 75S-T6 Aluminum-Alloy Columns. NACA TN 3204, 1954.
4. Popov, E. P.: Bending of Beams With Creep. Jour. Appl. Phys., vol. 20, no. 3, Mar. 1949, pp. 251-256.
5. Osgood, William R.: Plastic Bending. Jour. Aero. Sci., vol. 11, no. 3, July 1944, pp. 213-226.
6. Cozzone, Frank P.: Bending Strength in the Plastic Range. Jour. Aero. Sci., vol. 10, no. 5, May 1943, pp. 137-151.
7. Larson, F. R., and Miller, James: A Time-Temperature Relationship for Rupture and Creep Stresses. Trans. A.S.M.E., vol. 74, no. 5, July 1952, pp. 765-771; Discussion, pp. 771-775.
8. Doerr, Dale D.: Compressive, Bearing, and Shear Properties of Several Non-Ferrous Structural Sheet Materials (Aluminum and Magnesium Alloys and Titanium) at Elevated Temperatures. Proc. A.S.T.M., vol. 52, 1952, pp. 1054-1078.
9. Roberts, William M., and Heimerl, George J.: Elevated-Temperature Compressive Stress-Strain Data for 24S-T3 Aluminum-Alloy Sheet and Comparisons With Extruded 75S-T6 Aluminum Alloy. NACA TN 1837, 1949.
10. Shepard, Lawrence A., Starr, C. Dean, Wiseman, Carl D., and Dorn, John E.: Intermittent Load Creep Tests on 75S-T6 at 600°F and Static and Intermittent Load Creep Tests on 24S-T3 at 300°F and 450°F. Twentieth Progress Rep. (Ser. 45, Issue 6, Contract No. AF 33-(038)-11502), Univ. of Calif. Inst. Eng. Res., Jan. 1, 1953.

11. Vawter, F. J., Guarnieri, G. J., Yerkovich, L. A., and Salvaggi, J.: Investigation of the Compressive, Bearing, and Shear Creep-Rupture Properties of Aircraft Structural Metals and Joints at Elevated Temperatures. Rep. No. KB-831-M-2 (Contract No. AF 33(616)-190), Cornell Aero. Lab., Inc., Dec. 1, 1952.
12. Vawter, F. J., Guarnieri, G. J., Yerkovich, L. A., and Salvaggi, J.: Investigation of the Compressive, Bearing, and Shear Creep-Rupture Properties of Aircraft Structural Metals and Joints at Elevated Temperatures. Rep. No. KB-831-M-3 (Contract No. AF 33(616)-190), Cornell Aero. Lab., Inc., Feb. 1, 1953.
13. Anon.: Strength of Metal Aircraft Elements. ANC-5, Munitions Board Aircraft Committee, Dept. of Defense. Revised ed., June 1951.
14. Heimerl, George J.: Time-Temperature Parameters and an Application to Rupture and Creep of Aluminum Alloys. NACA TN 3195, 1954.

TABLE I.- DIMENSIONS OF 24S-T3 ALUMINUM-ALLOY MULTIWEB BOX BEAMS

Beam	Beam depth, in.		Cover plate, in.		Web thickness, in.	Total length, in.
	Tip	Root	Width	Thickness		
1	2.79	3.77	10.75	0.126	0.064	96.0
2	2.78	3.78	10.78	.126	.064	96.0
3	2.77	3.75	10.75	.126	.065	96.0
4	2.78	3.80	10.78	.126	.064	96.0
5	2.78	3.78	10.77	.127	.064	96.0
6	2.78	3.78	10.77	.126	.065	96.0
7	2.77	3.78	10.76	.126	.064	96.0

TABLE II.- STATIC-STRENGTH TEST CONDITIONS AND RESULTS

Beam	Test temp., °F	Exposure time, hr	Maximum tip load, lb	Magnitude of failure stress, ksi (a)	Type of failure	Predicted failure stress, ksi (fig. 6)	Predicted maximum tip load, lb
1	Room temp.	---	7,860	50.4	Compressive	47.3	7,370
2	370	1/2	6,340	40.7	Compressive	41.7	6,490
3	425	2	6,120	41.7	Tensile	43.2	6,340

^aFailure stress, corresponding to maximum test load, calculated by assuming a fully plastic rectangular stress distribution on beam cross section.

TABLE III.- CREEP TEST CONDITIONS AND RESULTS

Beam	Test temp., °F	Type of heating	Tip load, lb	Maximum bending stress, ksi (a)	Failure time, hr	Type of failure	Predicted tensile failure time, hr (fig. 8)
4	375	Continuous	5,400	39.1	23.8	Tensile	22.5
5	425	Continuous	3,750	27.3	37.8	Tensile	38.7
6	425	Intermittent	3,400	24.4	64.0	Compressive	81.2
7	Varied	Intermittent	4,175	30.0	32.3	Tensile	(See table IV)

^aBending stress in cover plate at beginning of creep test calculated from elementary beam theory.

TABLE IV.- CREEP TEST RESULTS FOR BOX BEAM 7 SUBJECTED TO CONSTANT
 LOAD AND VARYING TEMPERATURES

(1)	(2)	(3)	(4)
Test temp., °F	Time at test temp., hr (a)	Predicted tensile failure time, hr (fig. 8)	Part of lifetime exhausted at each test temp., percent, i.e. $\frac{(2)}{(3)} \times 100$
375	9.45	219.5	4.3
400	2.35	60.1	3.9
410	4.50	36.6	12.3
415	4.25	28.6	14.9
420	5.35	22.5	23.8
430	1.00	14.0	7.1
435	4.30	11.1	38.7
Total	31.20		105.0

^aAdjusted for heating and cooling periods reduced to equivalent time at test temperature.

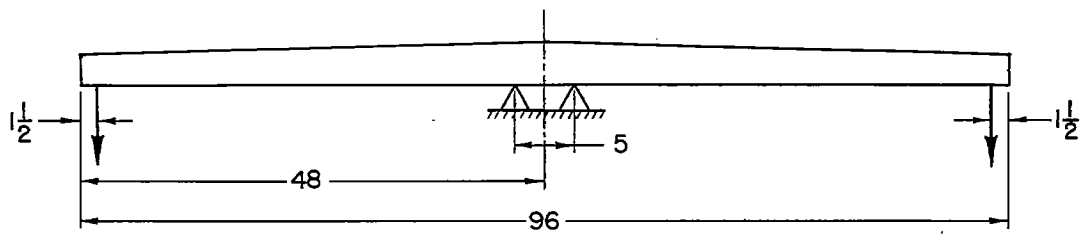
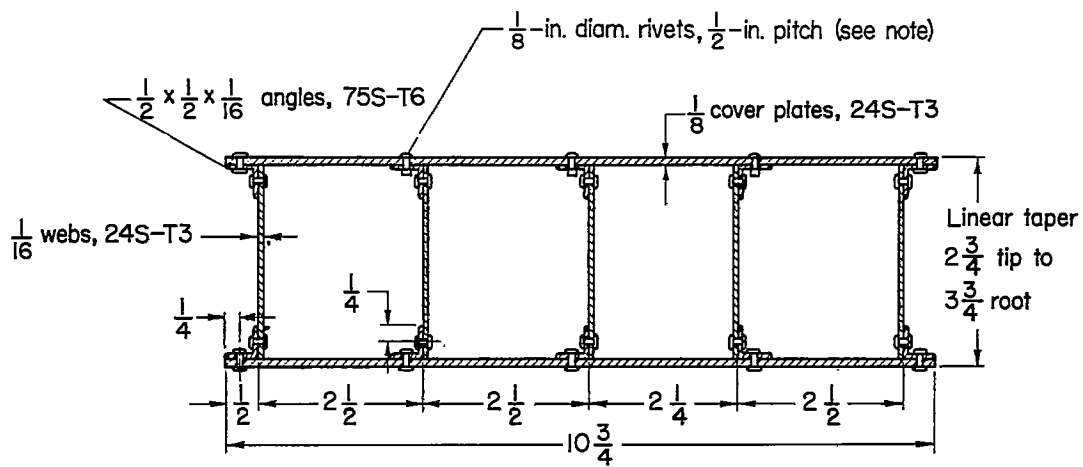

Figure 1.- View of box beam showing support locations and points of application of loads.



Note: All rivets are flat-head A17S-T4 except three inner rows in top cover which are Huck blind rivets, brazier head, type P4G.

Figure 2.- Typical cross section of box beam.

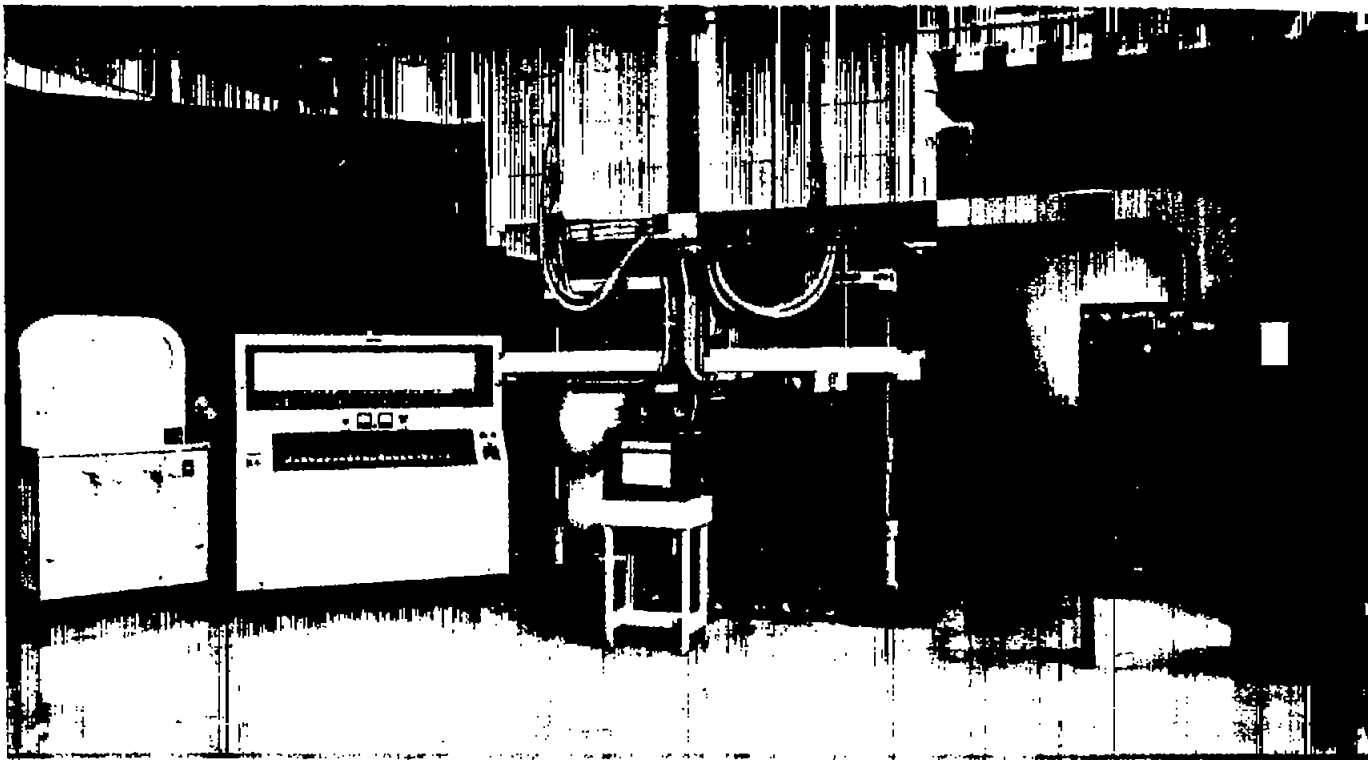
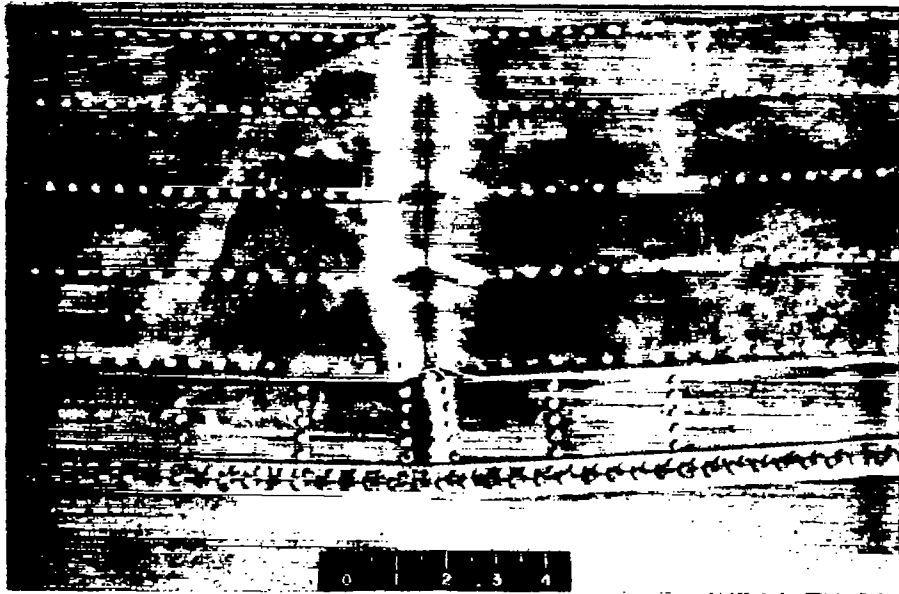
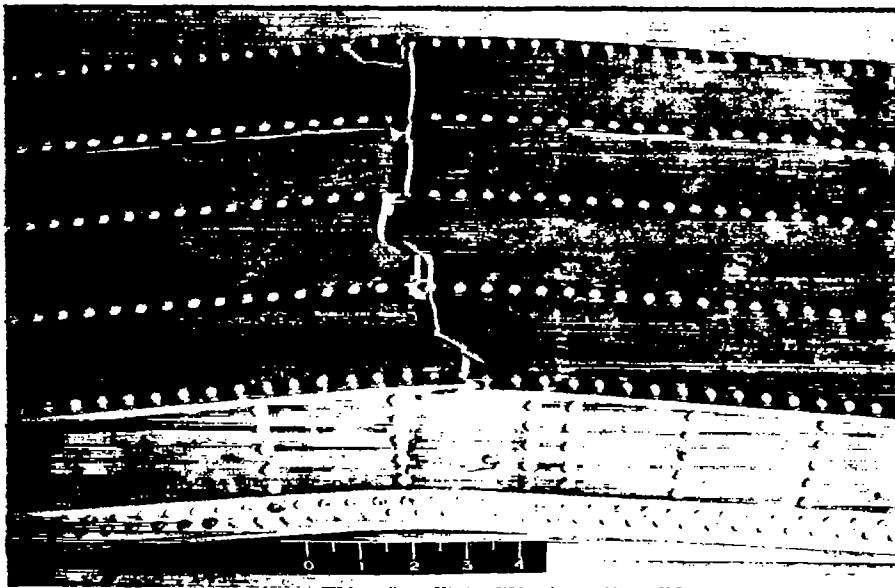

Figure 3.- Test equipment.

L-80960



(a) Compressive failure, bottom cover plate. L-81511



(b) Tensile failure, top cover plate. L-81512

Figure 4.- Typical failures of 24S-T3 aluminum-alloy multiweb box beams in static-strength tests.

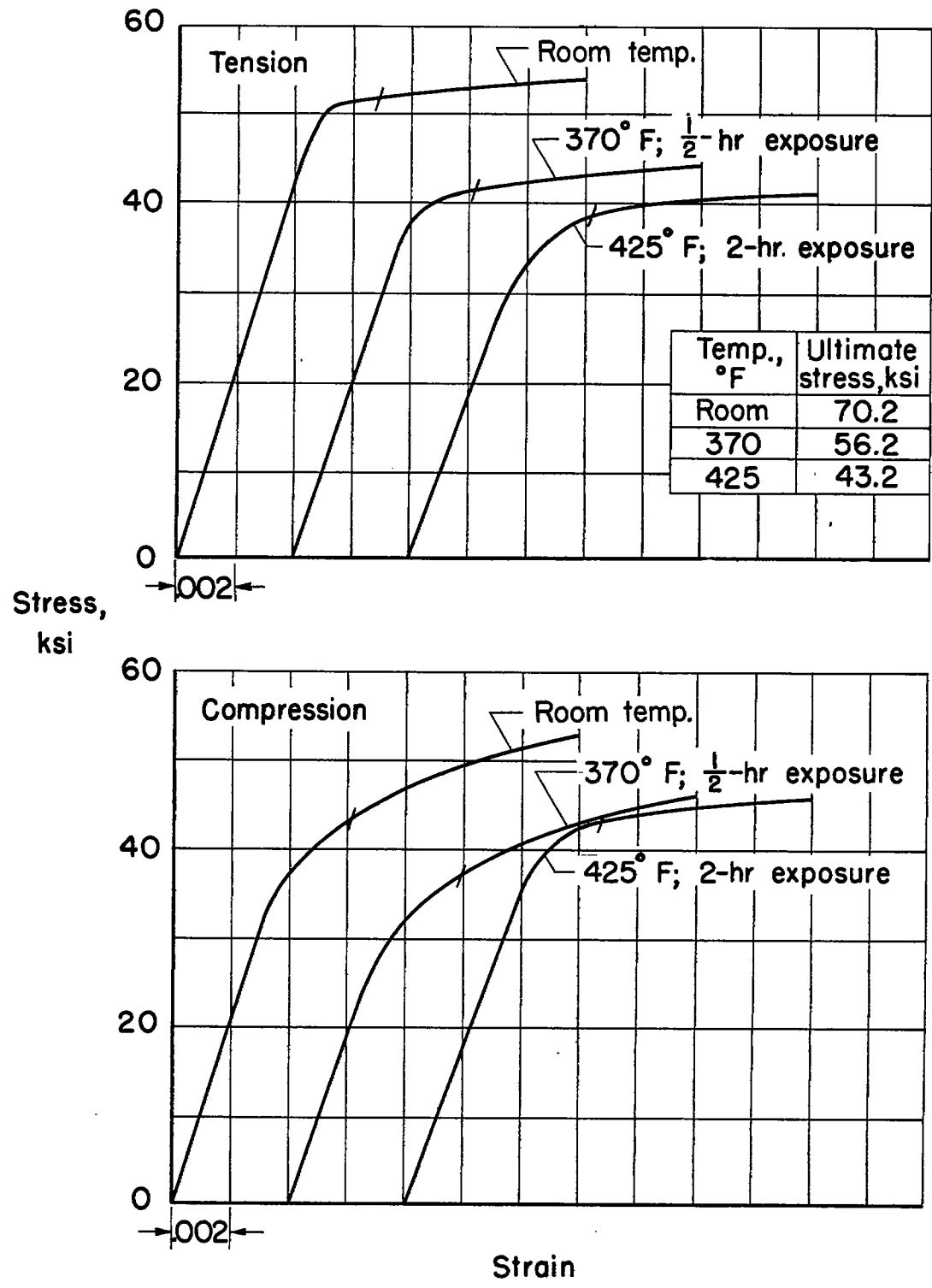

Figure 5.- Tensile and compressive stress-strain curves for 24S-T3 aluminum alloy. Specimen thickness, 1/8 inch; strain rate, 0.002 per minute.

Box-beam static-strength test results

- Compressive failure
- Tensile failure

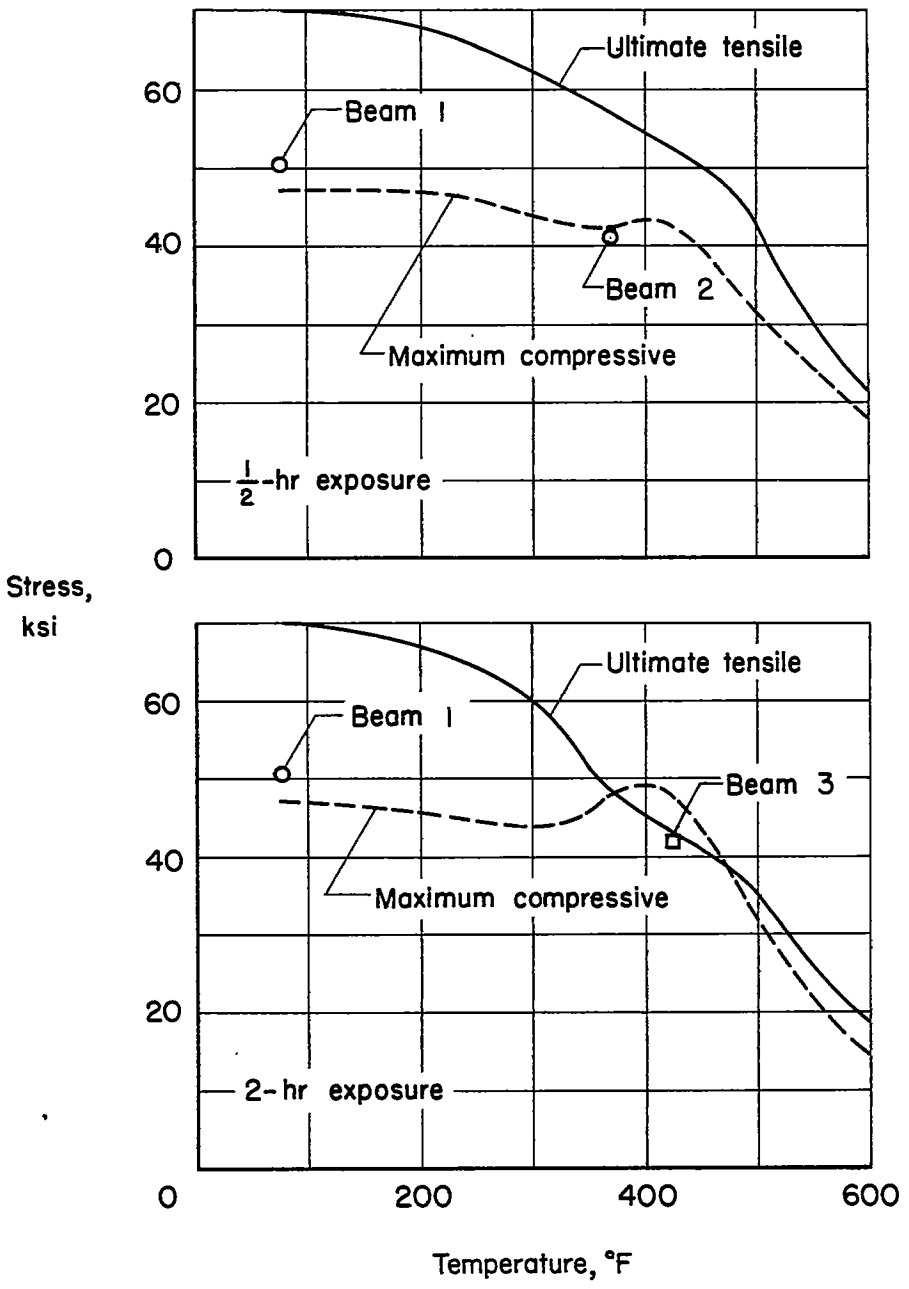
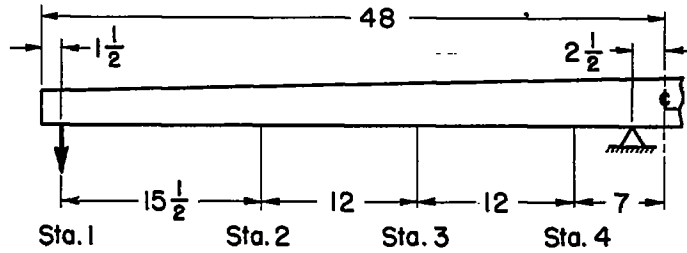
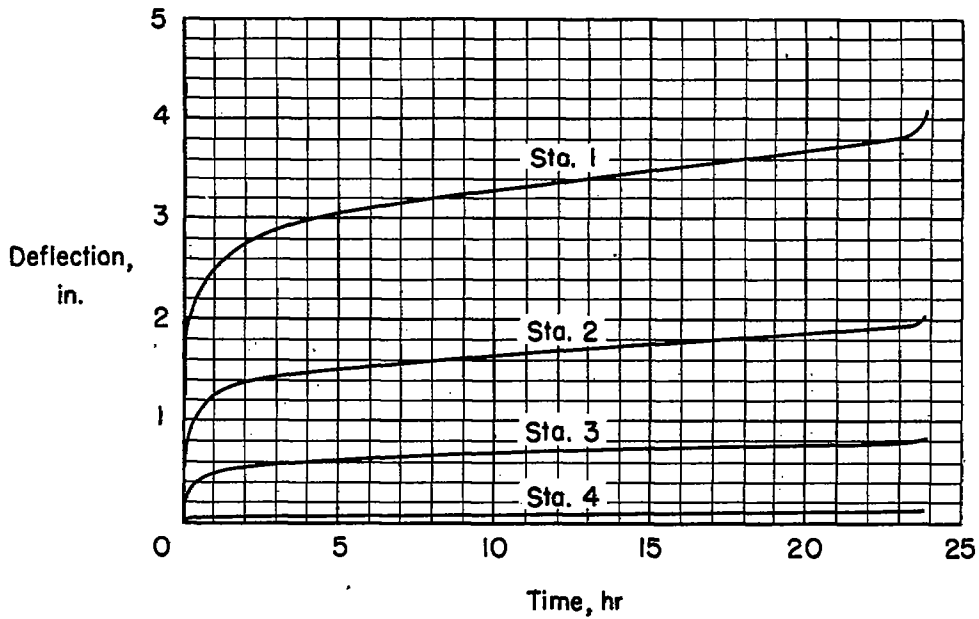

Figure 6.- Variations of ultimate tensile stress and maximum compressive stress with temperature for 24S-T3 aluminum-alloy box beams. (Box-beam static-strength test results included.)



(a) Stations on longitudinal center line at which creep deflections were measured.



(b) Beam 4; test temperature, 375° F; tip load, 5,400 lb (85 percent of load required to produce immediate failure at 375° F). Tensile failure.

Figure 7.- Creep deflections of 24S-T3 aluminum-alloy multiweb box beams.

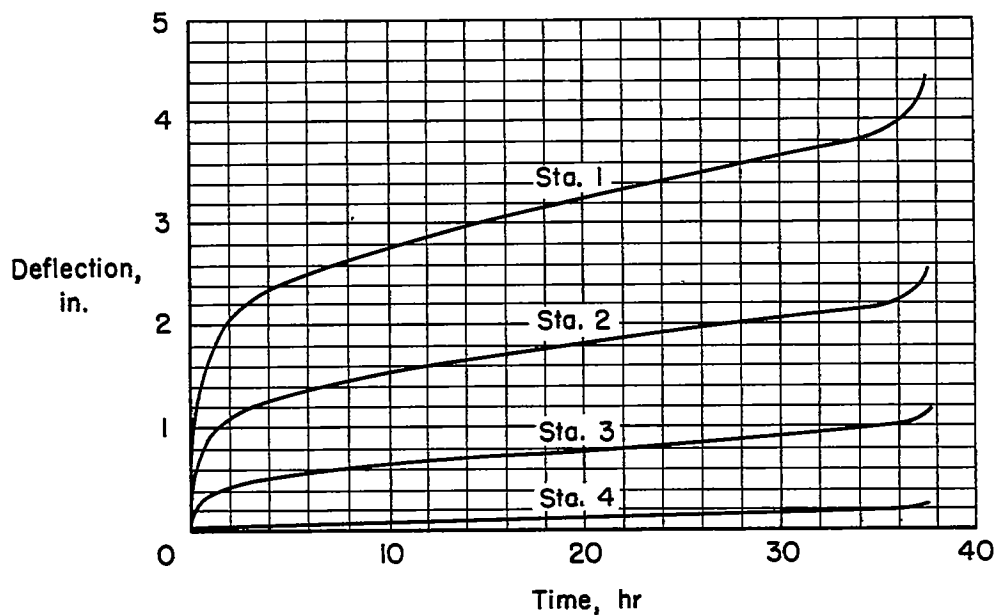

(c) Beam 5; test temperature, 425° F; tip load, 3,750 lb (61 percent of load required to produce immediate failure at 425° F). Tensile failure.

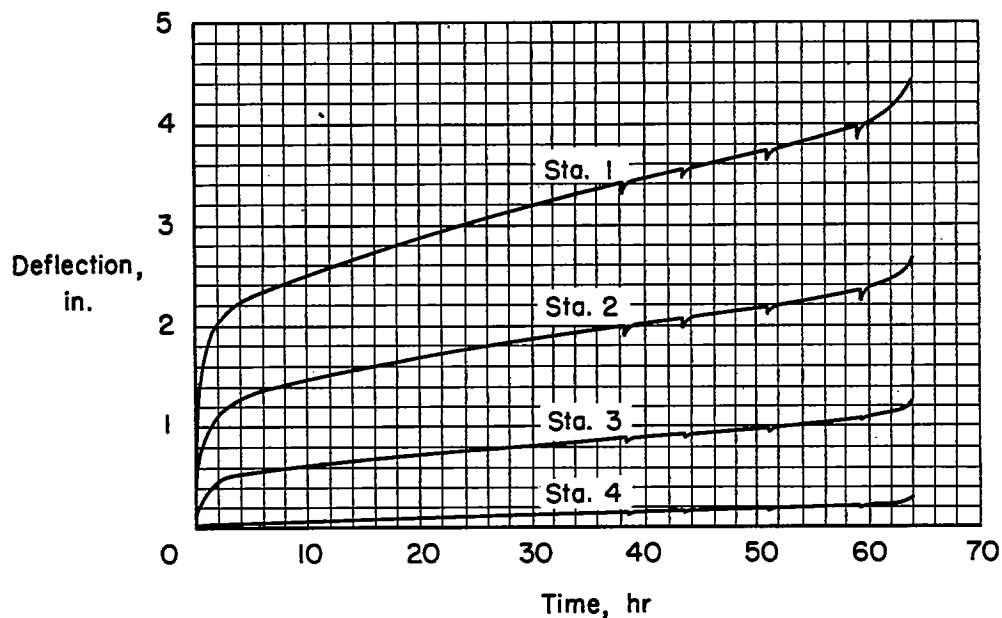

(d) Beam 6; test temperature, 425° F; tip load, 3,400 lb (56 percent of load required to produce immediate failure at 425° F). Beam temperature reduced to room temperature for 16 hours at each discontinuity. Compressive failure.

Figure 7.- Continued.

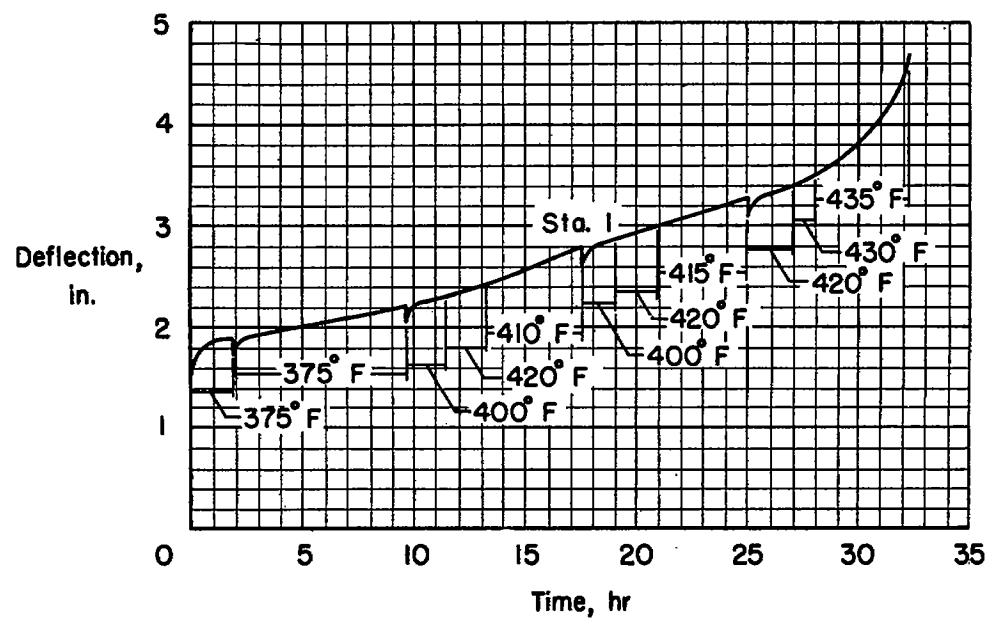

(e) Beam 7; test temperature varied; tip load, 4,175 lb. Beam temperature reduced to room temperature for 16 hours at each discontinuity. Tensile failure.

Figure 7.- Concluded.

NACA-Langley - 11-10-84 - 1000

NACA TN 3310

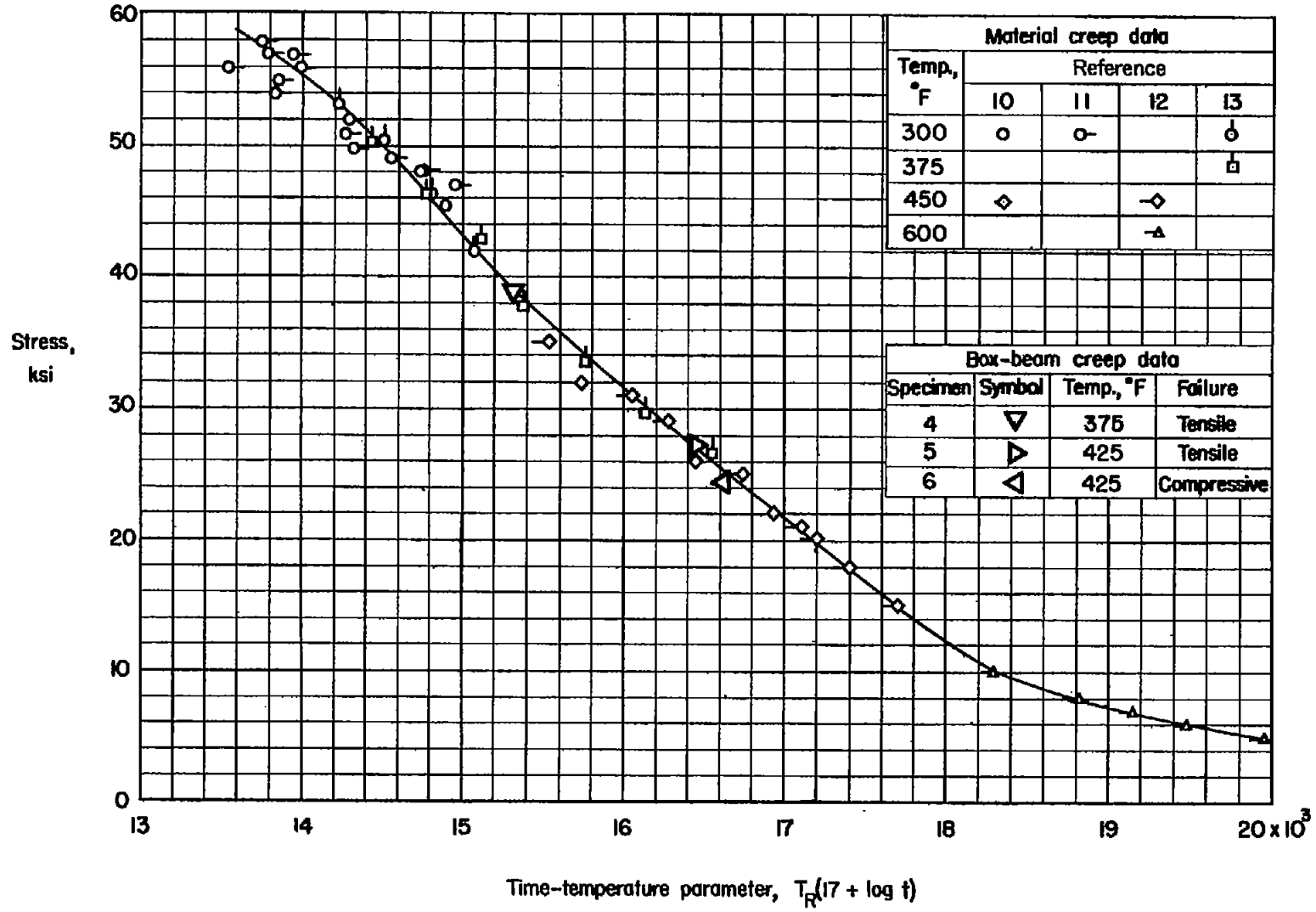

Figure 8.- Master rupture curve for 24S-T3 aluminum alloy and results of box-beam creep tests.