

COMMITTEE
AERONAUTICS
NOV 21 1930

THIS DOCUMENT PROVIDED BY THE ABBOTT AEROSPACE
TECHNICAL LIBRARY
ABBOTTAEROSPACE.COM

~~205~~
~~40~~
~~STJ~~

L. M. A. L.



TECHNICAL NOTES

NATIONAL ADVISORY COMMITTEE FOR AERONAUTICS

No. 356

SOME CHARACTERISTICS OF FUEL SPRAYS FROM OPEN NOZZLES

By A. M. Rothrock and D. W. Lee
Langley Memorial Aeronautical Laboratory

FILE COPY

To be returned to
the files of the Langley
Memorial Aeronautical
Laboratory.

Washington
November, 1930

NATIONAL ADVISORY COMMITTEE FOR AERONAUTICS.

TECHNICAL NOTE NO. 356.

SOME CHARACTERISTICS OF FUEL SPRAYS FROM OPEN NOZZLES.

By A. M. Rothrock and D. W. Lee.

Summary.

The penetration and cone-angle of fuel sprays from open nozzles were recorded with the N.A.C.A. Spray Photography Equipment. The results show that for injection systems in which the rate of pressure rise at the discharge orifice is high, open nozzles give spray-tip velocities and penetrations which compare favorably with those of closed nozzles. The spray cone-angle was the same for all tests, although open nozzles having different orifice diameters were used, and one nozzle was used both as an open and as a closed nozzle. In designing a fuel system using open nozzles, particular care must be taken to avoid air pockets. The check valve should be placed close to the discharge orifice.

Introduction.

When open nozzles are used in solid-injection engines, no injection valve is necessary. Instead, a check valve is used to prevent the flowing of cylinder gases into the fuel system during the part of the cycle when no fuel is being

injected. This arrangement simplifies the injection system. The open nozzle is now used on the Packard and Junkers aircraft Diesel engines, showing that its advantages are being recognized. However, with pump injection systems such as are on these engines, the open nozzle gives low spray-tip velocities during the start of injection and also at low speeds because the pressures forcing the fuel through the discharge orifice are necessarily low (Reference 1). The open nozzle will probably find more favor in a fuel injection system in which the rate of pressure rise at the discharge orifice is high at all engine speeds. Since the injection system of the N.A.C.A. Spray Photography Equipment (Reference 2) gives a high rate of pressure rise at the discharge orifice (Reference 3), an investigation was undertaken with this equipment to determine the spray characteristics of open nozzles and to compare these characteristics with those of closed nozzles. The tests were conducted at the Langley Memorial Aeronautical Laboratory, Langley Field, Va.

Apparatus and Methods.

The common rail injection system of the N.A.C.A. Spray Photography Equipment is shown diagrammatically in Figure 1. The liquid fuel was forced under pressure, by means of a hand pump, into the high-pressure reservoir. The timing-valve cam was operated by a clutch, which, when engaged, caused the cam-

shaft to make one revolution at a speed of 950 r.p.m. The rate of pressure rise at the discharge orifice is independent of the camshaft speed between the values of 470 and 1140 r.p.m., as has been shown in Reference 3. As the timing-valve cam lifted the timing-valve needle from its seat, the fuel under pressure in the reservoir was released through the injection tube to the discharge orifice. Approximately 0.004 second later, a second cam opened the by-pass valve, releasing the fuel to atmospheric pressure. Since the area of the by-pass valve greatly exceeded the area of the discharge orifice, the pressure quickly dropped to atmospheric, which caused the injection to cease. The air in the spray chamber was maintained at densities corresponding to those in the combustion chambers of compression-ignition engines, but the air was at atmospheric temperature. High-speed motion pictures of the spray were taken at the rate of approximately 4000 per second with the N.A.C.A. Spray Photography Equipment (Reference 2). A typical series of photographs is shown in Figure 2.

The penetration of the spray tip was measured from a smooth curve drawn through the spray tips of the successive photographs (Figure 2). The method of measuring the spray cone-angle is also indicated. The figure shows that the start of injection was obtained by extending the time-penetration curve to zero penetration. This method resulted in an inaccuracy in the time of the start of injection and in the form of the curve during the starting interval.

With the open nozzles, a study of the start of penetration was particularly desired. Consequently, continuous photographs were obtained of the movement of the spray tip. The apparatus was altered by mounting a 1000-watt bulb in the reflector of the spray photography equipment. The light was focused on the spray chamber as it was with the spark discharges. The camera was equipped with an automatic shutter which was operated from the camshaft so that the light from the 1000-watt bulb, reflected from the fuel spray, was admitted to the camera lens only during the injection of the fuel spray. The shutter timing was varied in the same manner as the spark timing (Reference 2). A characteristic spray photograph, taken in this manner, is shown in Figure 3. From these photographs, continuous spray-tip penetration curves were drawn. In the photographs reproduced in this report, the start of injection has been retouched because the light reflected from the edge of the spray chamber obscured the image of the spray.

The open-nozzle holder and the open nozzles are shown in Figure 4. The nozzles were all made geometrically similar so that their discharge coefficients would be the same (Reference 4). The tests on the open nozzles were made with and without the ball-check valve shown in the figure. The tests with the check valve were made with the valve mounted as shown, and with the valve mounted adjacent to the by-pass and timing valve connections. The minimum flow area in this valve is .005 square inch, or about seven times the area of the largest nozzle orifice

used.

The nozzle used in the comparison of the open and closed nozzles is shown in Figure 5. For the open nozzle tests it was mounted in the holder shown in Figure 4; and for the closed nozzle tests, it was mounted in the automatic injection valve shown in Figure 5.

The fuel was a high grade Diesel oil with a specific gravity of 0.85 at 80°F. and a viscosity of 0.048 poise, or 44 Saybolt Universal seconds, at atmospheric pressure and 80°F.

The injection tubes had an internal diameter of 1/8 inch and an external diameter of 1/4 inch.

Test Results and Discussion.

Tests without check valve.— The open nozzles were first tested without the check valve in place. Just before each photograph was taken, the initial-pressure control valve (Figure 1) was opened, and fuel forced through the nozzle with the hand pump to eliminate any air that had entered the system owing to the absence of the check valve.

Figure 6 shows, for the three orifice sizes, the effects of injection pressure on the spray-tip penetration. Each curve of Figure 6 was obtained from an average of several records taken under the same test conditions, since the spray-tip penetration varied in successive tests, although the experimental conditions were apparently the same. An examination of many

photographs, taken with the spark discharge, led to the conclusion that any decided change in the spray-tip velocity of a single spray was accompanied by a change in form of the spray tip. The spray-tip velocity was greater when the tips were pointed than when they were rounded. An example of this is shown in Figure 2. The second and third photographs show sharp tips and high-tip velocities, whereas the photographs following show a rounding of the tip and a lower velocity.

Beardsley (Reference 5), in his investigation of the reproducibility of fuel sprays, found that an initial pressure of 1000 lb. per sq. in. in the injection tube was necessary to reproduce results consistently. The present tests were made either with atmospheric initial pressure, or with an initial pressure equal to the chamber pressure when the check valve was not used. However, the variation in photographs taken under the same test conditions was small (compare Figures 2 and 3). That this variation is not a characteristic of open nozzles only is shown by Beardsley's work (Reference 5), as well as by records made with closed nozzles in the present investigation.

The curves in Figure 6 show that, when either the orifice diameter was increased or the injection pressure was decreased, there was a tendency for the curves at the start of injection to show a reverse curvature. This phenomenon is explained by the work of Rothrock (Reference 3) on the pressure variations

in the injection system used in these tests. The rate of pressure rise at the discharge orifice was found to decrease either with an increase in orifice diameter or with a decrease in injection pressure. The trend of the curves for the varying pressures and orifice diameters is the same as found by Gelalles in his investigation of closed nozzles (Reference 6).

Figure 7, which also represents the average of several tests, shows the effect of the density of the air in the spray chamber on the spray penetration. Again, the effect was the same as with the closed nozzles (Reference 7).

Figure 8 shows the effect of injection-tube length on the spray-tip penetration. There is little difference in the penetration for the different tube lengths, nor is any definite trend apparent. Beardsley (Reference 5), in his work on sprays from closed nozzles, found that the penetration increased slightly with an increase in tube length. In Figure 8, and in the figures following, each curve was plotted from a single record.

Effect of check valve on spray penetrations.— The effect of the check valve on the spray characteristics was determined. The results are shown in Figures 9 and 10. In the test from which curve 1 of Figure 9 was obtained, no check valve was used, but the line was carefully filled with fuel just before each injection occurred. Curve 2 was obtained in the same manner, except that the check valve was inserted in the line

between the by-pass and timing-valve connection and the injection tube. A comparison of the two curves indicates that the check valve restricted the flow. The tests from which curves 3 and 4 were obtained were made under the same conditions as the test for curve 2, except that the line was not filled with fuel by the hand pump before each injection. Curve 3 was obtained from an injection made a few seconds after the previous injection, and curve 4 is from an injection made several minutes after a preceding injection. The curves show that both injections were unsatisfactory. Possibly after the timing valve closed, some of the fuel continued to discharge because of its inertia, and air, entering either through the by-pass valve or through the nozzle, caused the next injection to be materially affected.

The curves obtained from tests in which the check valve was placed in the nozzle holder gave much better results (Figure 10). The test from which each curve was obtained was run under the same conditions as the corresponding test represented in Figure 9. A comparison of curves 1, 2, and 3 of Figure 10 shows that there was virtually no restriction in the check valve, and that no air collected in the system between successive injections. In a high-speed engine, the time between injections is extremely short. Consequently, curve 3 may be applied to engine operating conditions. When several minutes elapsed between injections, curve 4 was obtained. The record from which curve 4 was plotted is shown in Figure 11. Apparently, at first a small amount of fuel was discharged from the

orifice at a low velocity. Approximately 0.001 second later, the main discharge occurred. This behavior was possibly due to the presence of air in the fuel system near the nozzle, the air having entered into the system during the interval between injections.

Comparison of spray penetration of open and closed nozzles.-

Figure 12 shows the results of the tests comparing the penetration of sprays from open and closed nozzles. With the closed nozzle, a valve opening pressure of 500 lb. per sq. in. less than the injection pressure, and an initial pressure of 500 lb. per sq. in., were used. When the system was first assembled with the open nozzle, the plotted results gave the curves shown as long and short dashes, even though the system was filled with oil before each injection. The system was disassembled and then reassembled carefully, removing all air from the system. The curves shown as short dashed lines were then obtained. The conclusion to be drawn is that, in the design of an injection system employing open nozzles, care must be taken to prevent the formation of air pockets.

A comparison of the curves in Figure 12 shows that the penetration at the start of injection was less with the open nozzles than with the closed. After approximately 0.0005 second, the curves for the open nozzles show a reverse curvature. Thereafter, the spray-tip velocity is approximately the same as that with the closed nozzles. The higher initial

spray-tip velocity for the closed nozzle is due to the fact that the fuel at the discharge orifice was under a high pressure before discharge started. With the open nozzle, discharge started as soon as the fuel pressure at the orifice exceeded the pressure in the spray chamber.

Spray cone-angle.- In all the data obtained, the spray cone-angle remained at approximately 18° , regardless of orifice size or whether an open or closed nozzle was used.

Conclusions.

The following conclusions are drawn from the test results presented:

1. When open nozzles are used with an injection system giving a high rate of pressure rise at the discharge orifice, the spray-tip velocities and the cone-angles of the sprays compare favorably with those of sprays from closed nozzles.
2. When using an open nozzle, the check valve should be placed close to the nozzle.
3. In designing an injection system for using open nozzles, care must be taken to avoid air pockets in the system.

Langley Memorial Aeronautical Laboratory,

National Advisory Committee for Aeronautics,

Langley Field, Va., November 5, 1930.

References.

1. Wild, J. E. : Combustion Chambers, Injection Pumps, and Spray Valves for Solid-injection Oil Engines. S.A.E. Journal, May, 1930.
2. Beardsley, E. G. : The N.A.C.A. Photographic Apparatus for studying Fuel Sprays from Oil Engine Injection Valves and Test Results from Several Researches. N.A.C.A. Technical Report No. 274, 1927.
3. Rothrock, A. M. : Pressure Fluctuations in a Common-rail Fuel Injection System. N.A.C.A. Technical Report No. 363, 1930.
4. Gelalles, A. G. : Coefficient of Discharge for Fuel Injection Nozzles for Compression-ignition Engines. N.A.C.A. Technical Report No. 373, 1931.
5. Beardsley, E. G. : Some Factors Affecting the Reproducibility of Penetration and the Cut-off of Oil Sprays for Fuel Injection Valves. N.A.C.A. Technical Report No. 258, 1927.
6. Gelalles, A. G. : Effect of Orifice Length-Diameter Ratio on Spray Characteristics. N.A.C.A. Technical Note No. 352, 1930.
7. Joachim, W. F.
and
Beardsley, E. G. : The Effects of Fuel and Cylinder Gas Densities on the Characteristics of Fuel Sprays for Oil Engines. N.A.C.A. Technical Report No. 281, 1927.

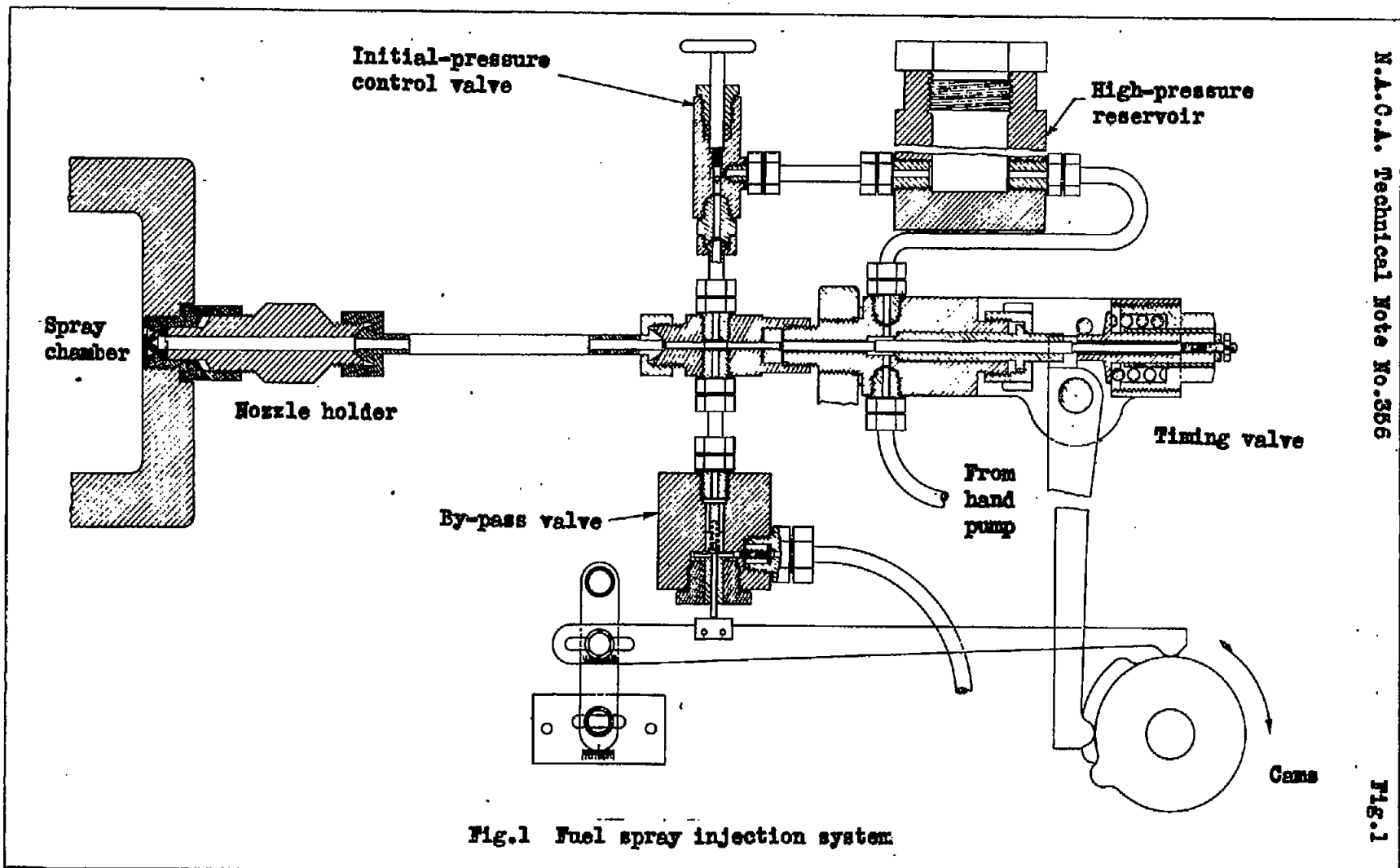

N.A.C.A. Technical Note No. 355

Fig. 1

Fig. 1 Fuel spray injection system

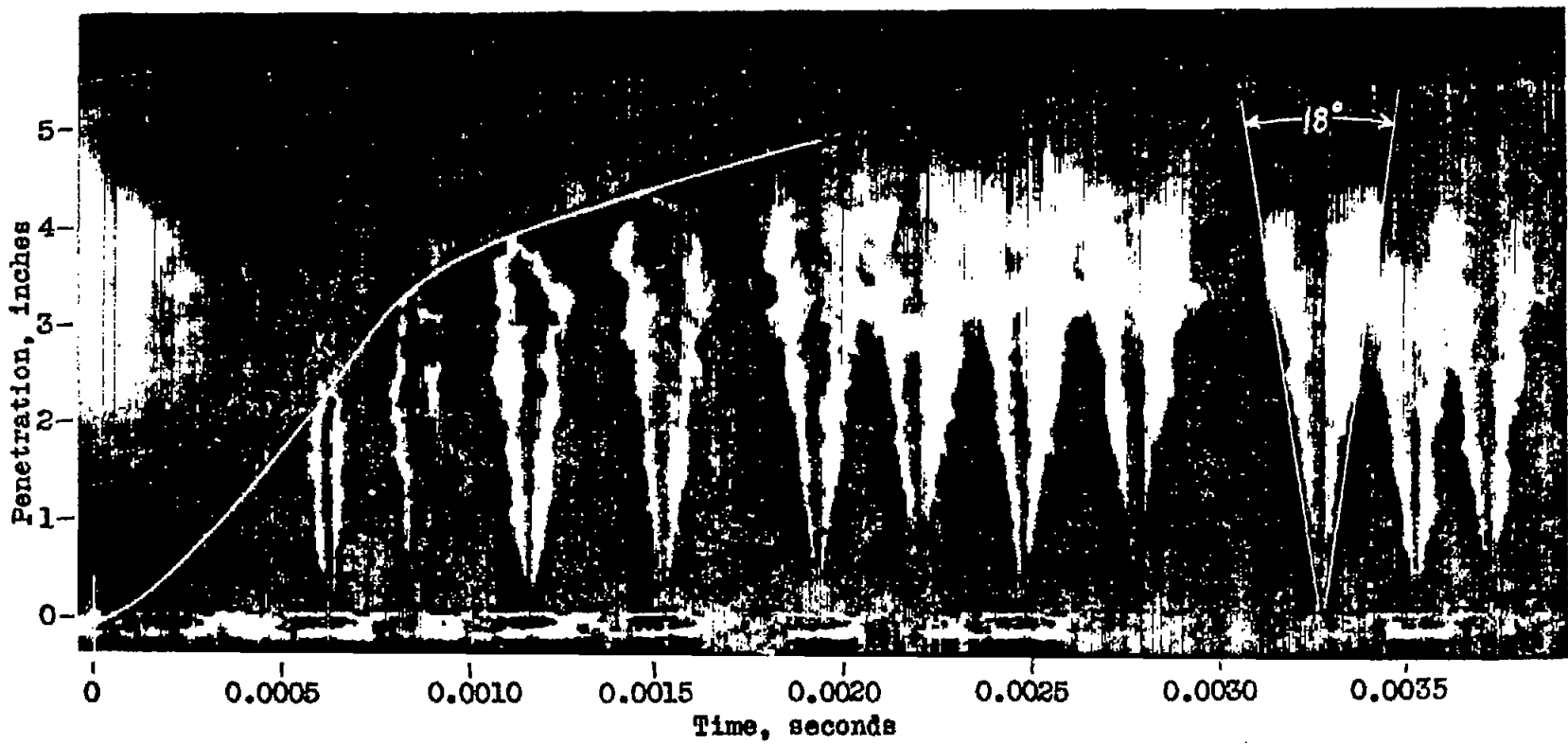

Fig.2 Spark photograph made with an open nozzle and without a check valve.
Nozzle diameter 0.020 in.
Injection pressure 4000 lb./sq.in.
Chamber air density 1.10 lb./cu.ft.

200 # Sq. in. Pressure

N.A.C.A. Technical Note No.356

Fig.2

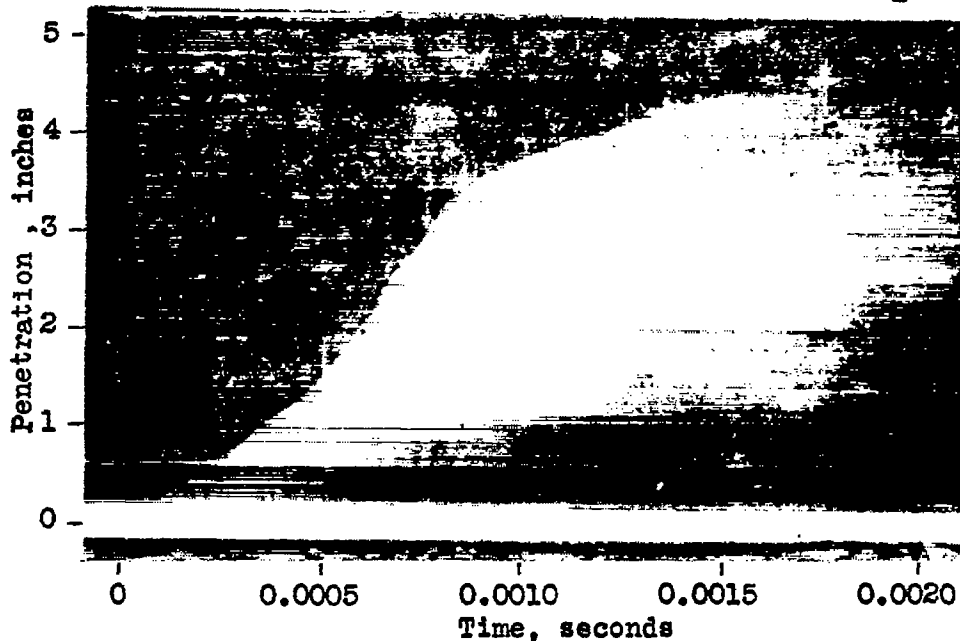

Fig.3 Spray penetration photograph made with an open nozzle and without a check valve.
Nozzle diameter 0.020 in.
Injection pressure. 4000 lb./sq.in.
Chamber air density 1.10 lb./cu.ft.

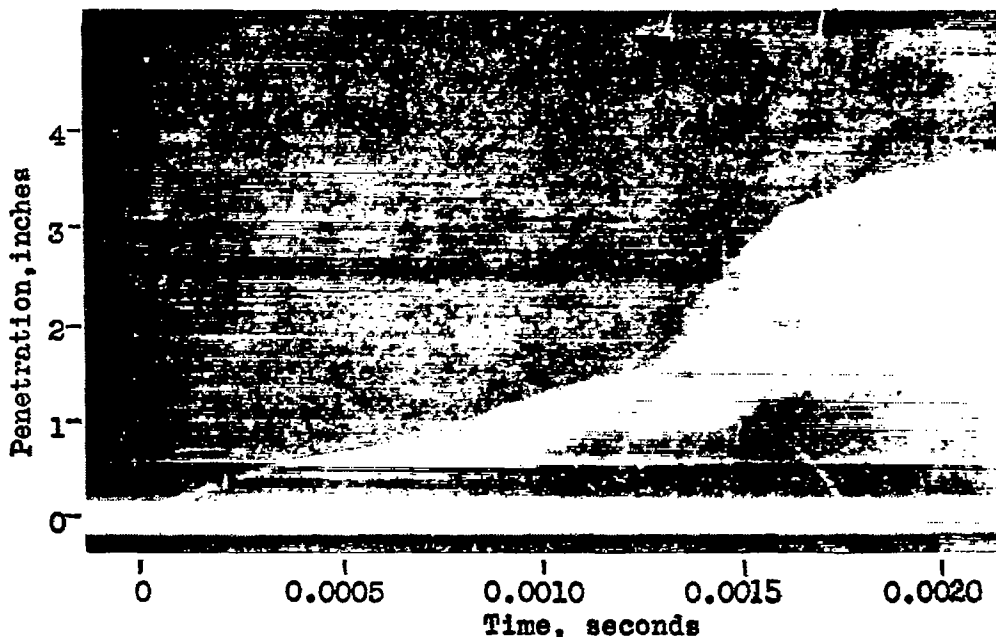
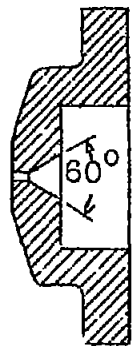
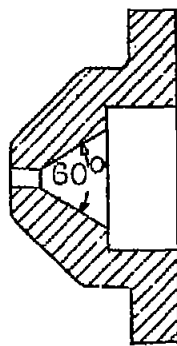

Fig.11 Spray penetration photograph made with an open nozzle and with a ball check-valve 2.5" from nozzle.
Nozzle diameter 0.020 in.
Injection pressure. 4000 lb./sq.in.
Chamber air density 1.10 lb./cu.ft.



.010 inch



.020 inch

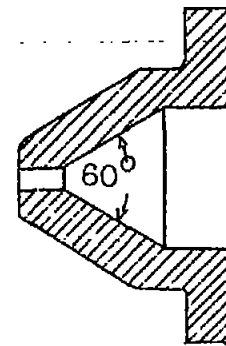

.030 inch

Open nozzles

Orifice length, twice orifice diameter.

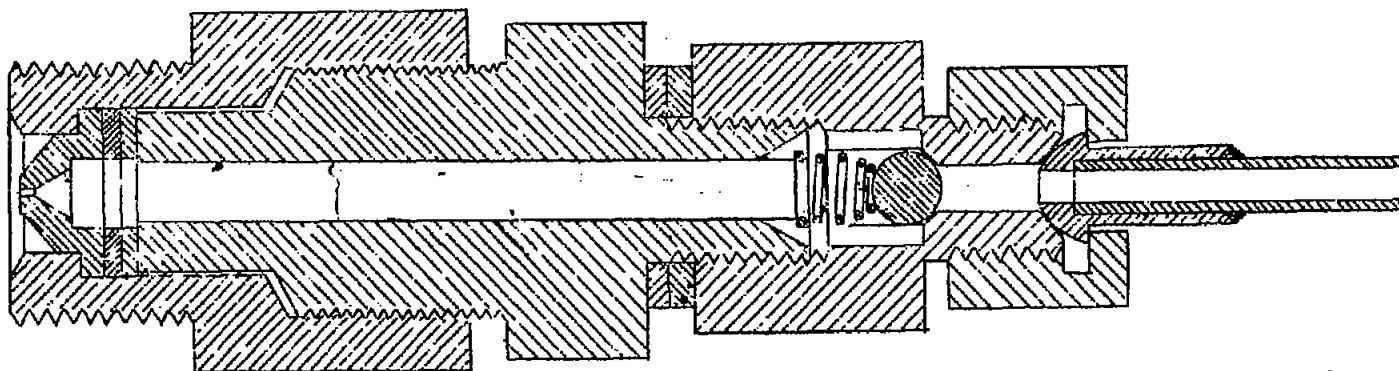

Fig.4 Open nozzle holder with ball check valve.

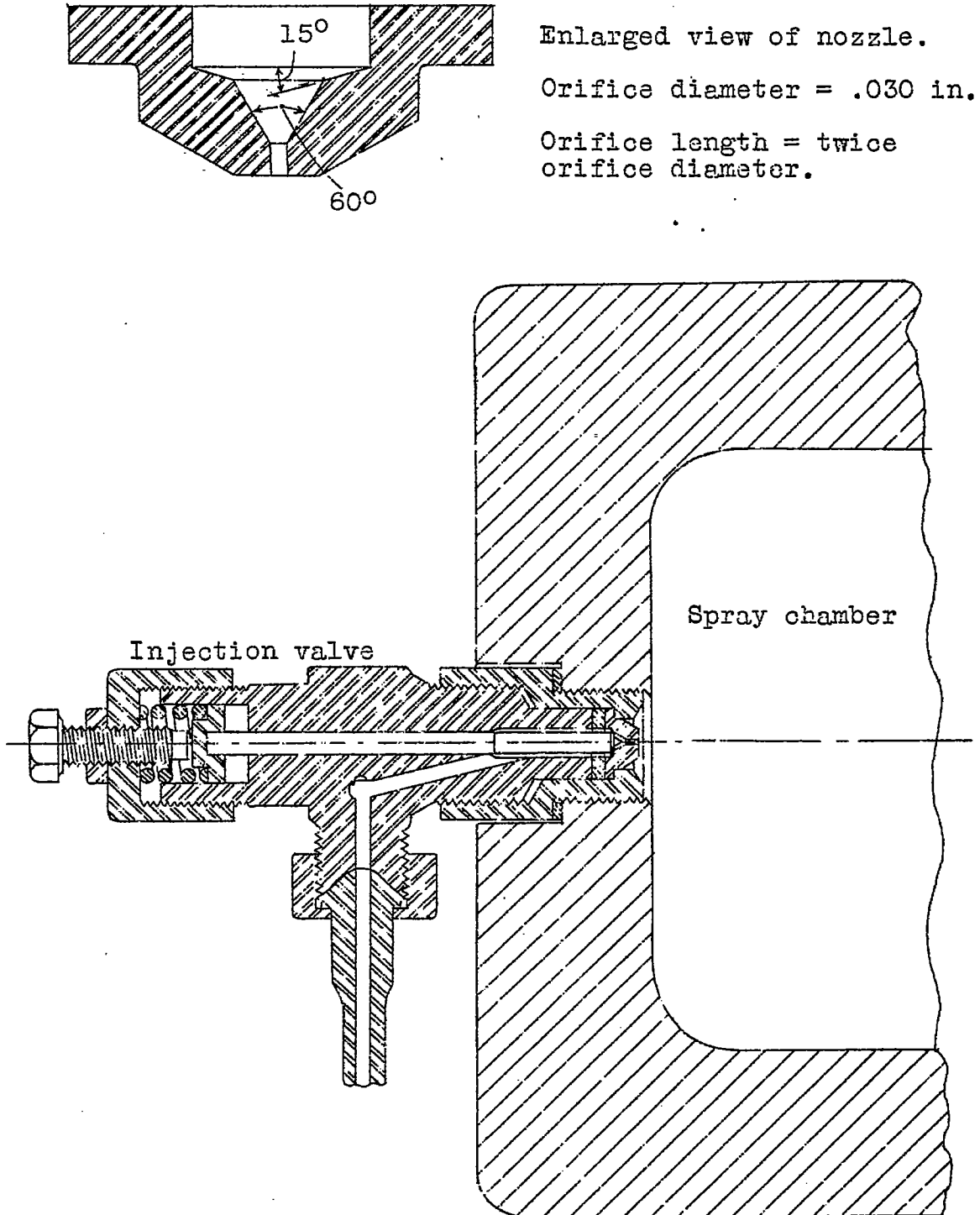

Fig.5 Automatic injection valve and nozzle used in comparison of open and closed nozzles.

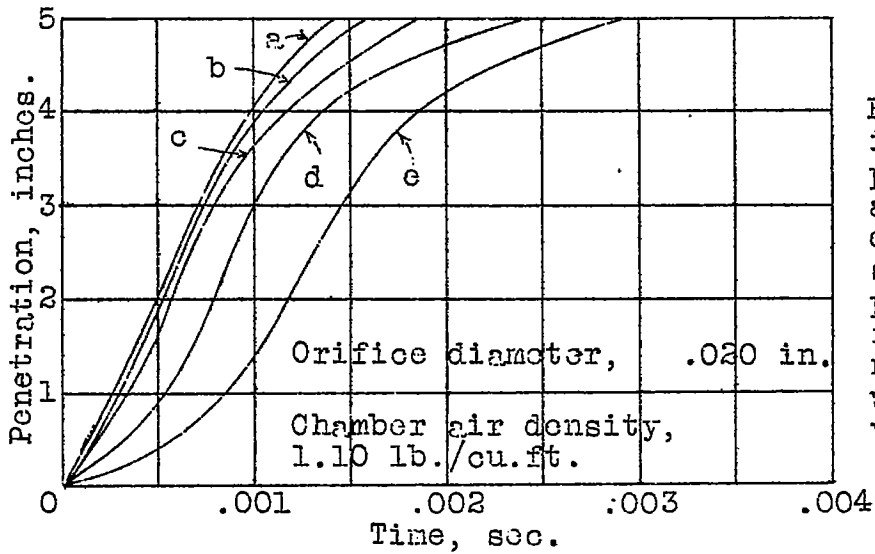
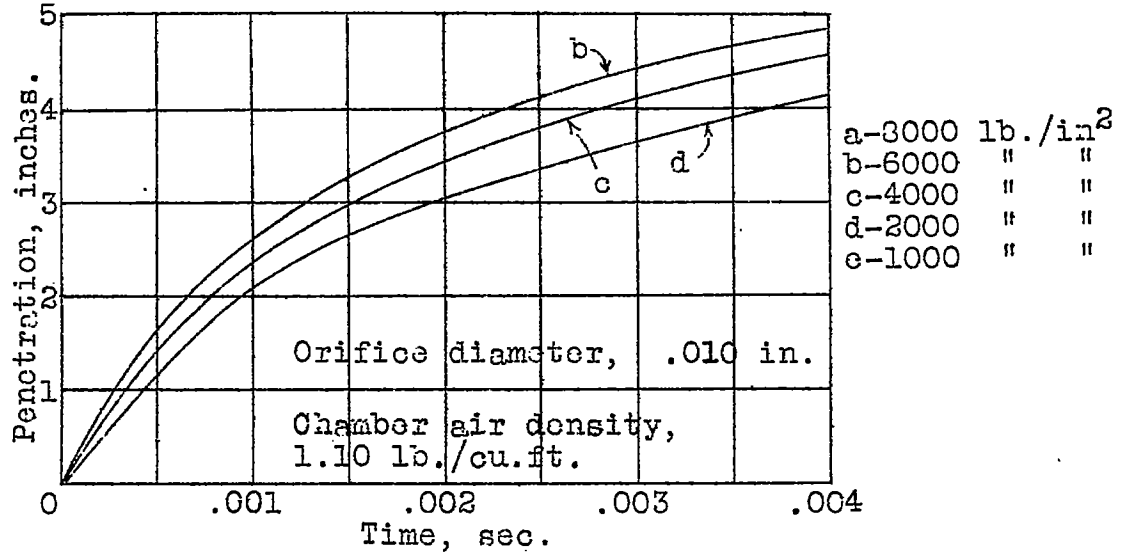
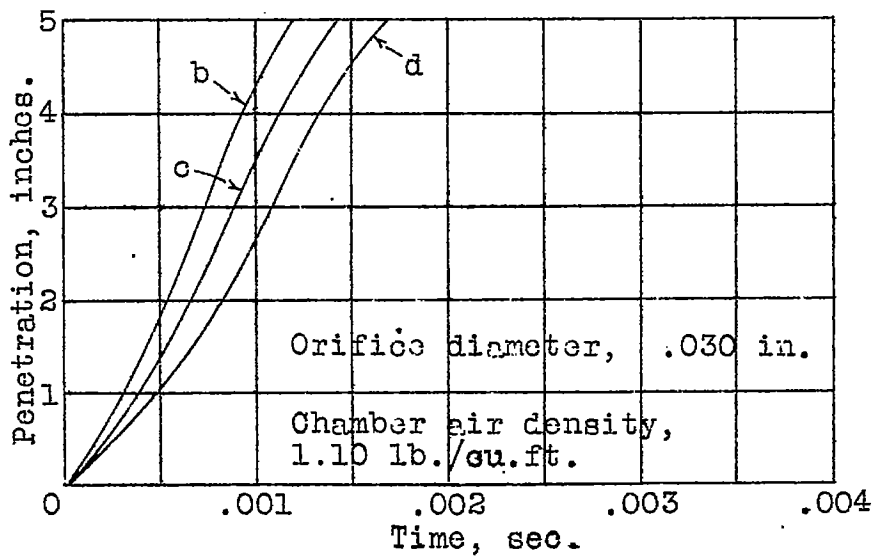

Fig. 6
 Effect of injection pressure and orifice diameter on spray tip penetration from open nozzels without check valve.



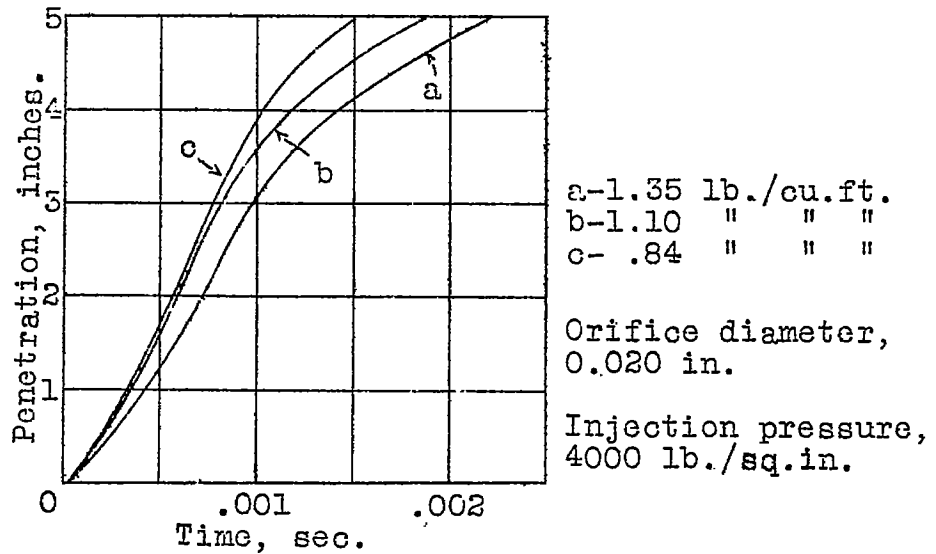

Fig. 7 Effect of chamber air density on spray tip penetration from an open nozzle without a check valve.

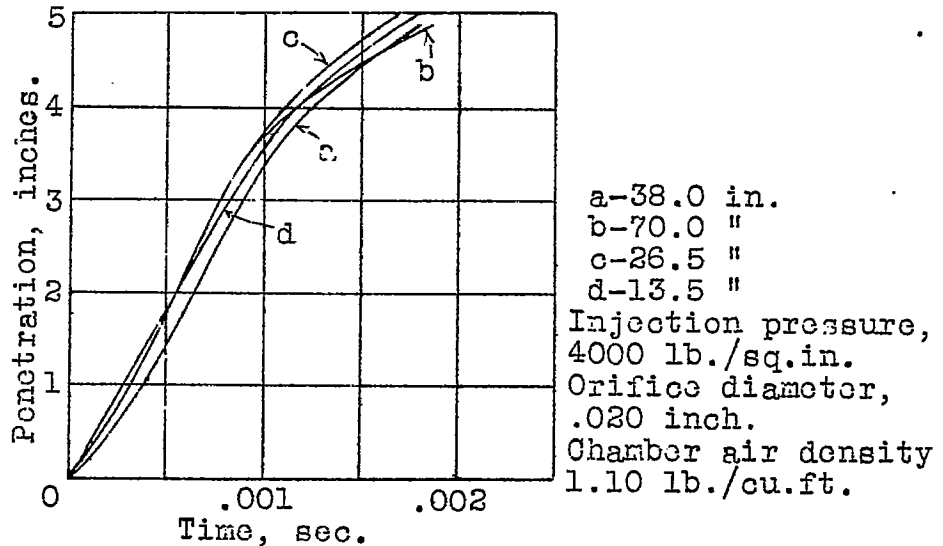
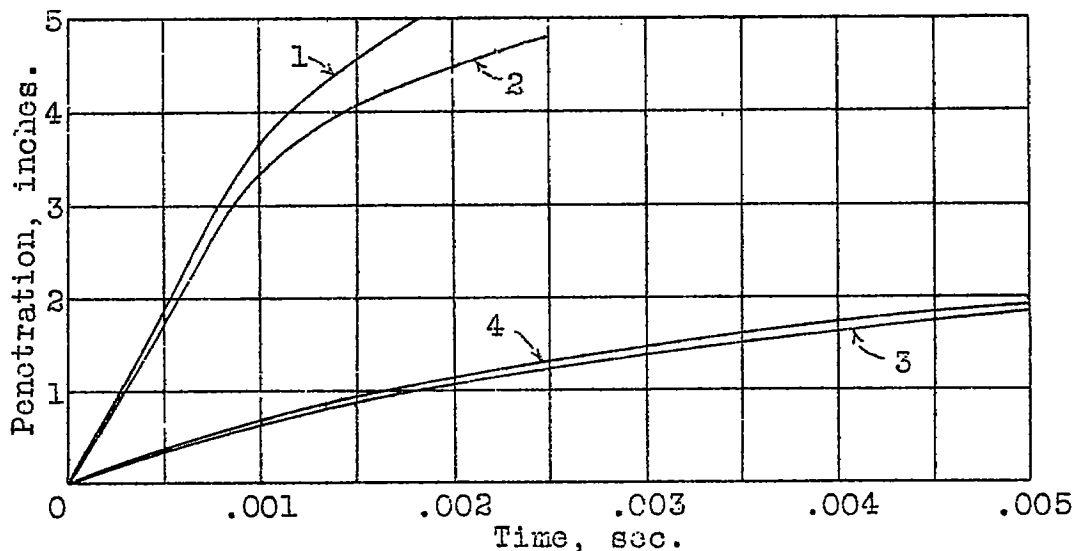

Fig. 8 Effect of injection tube length on spray tip penetration from an open nozzle without a check valve.

Injection pressure, 4000 lb./sq.in.
Chamber air density, 1.10 lb./cu.ft.
Orifice diameter, 0.020 inches.



- No. 1-No check valve in line. Tube filled with fuel by hand pump between injections.
- No. 2-Check valve adjacent to timing valve and by-pass valve connection. Tube filled with fuel by hand pump between injections.
- No. 3-Check valve located as for No. 2. Tube not filled with fuel by hand pump between injections. Record taken within a few seconds after preceding injection.
- No. 4-Same conditions as No. 3 except that several minutes elapsed since preceding injection.

Fig. 9 Effect of ball check-valve placed in fuel line near the timing valve on spray tip penetration from an open nozzle.

Injection pressure, 4000 lb./sq.in.
Chamber air density, 1.10 lb./cu.ft.
Orifice diameter, 0.020 inches.

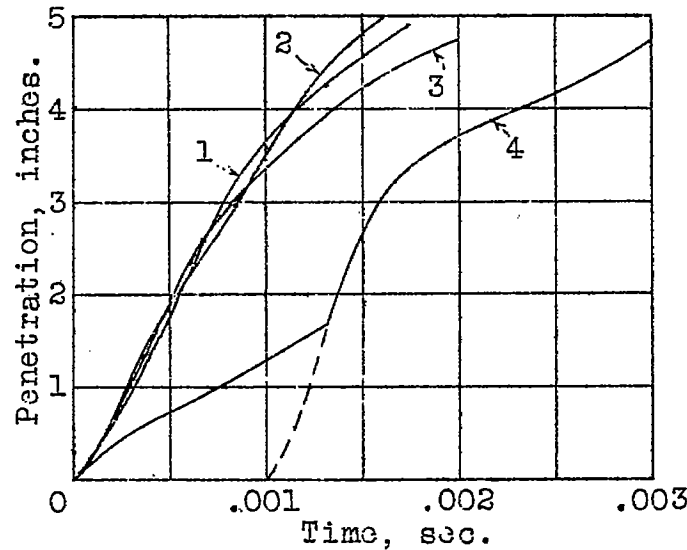

- No.1-No check valve used. Tube filled with fuel by hand pump between injections
No.2-Check valve in nozzle holder. Tube filled as in No. 1
No.3-Check valve in nozzle holder. Tube not filled by hand pump between injections. Record taken within a few seconds of preceding injection.
No.4-Same conditions as No.3 except that several minutes elapsed since preceding injection.

Fig. 10 Effect on spray tip penetration of a ball check-valve 2-1/2" from an open nozzle.

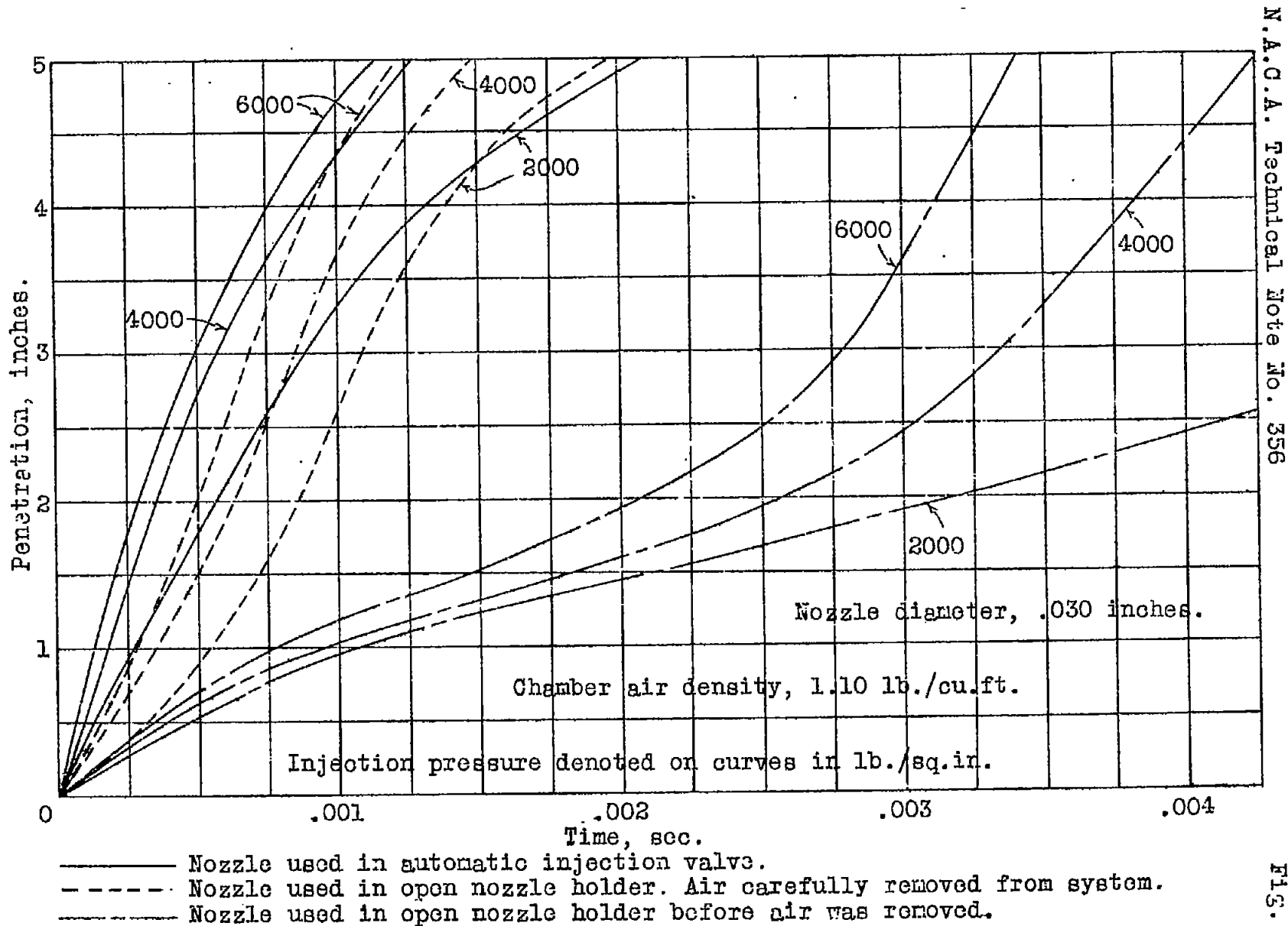

N.A.C.A. Technical Note No. 356

FIG. 12

Fig. 12 Spray penetrations with open and closed nozzle.