

10514
5174 NT ACAN
NACA TN 4175

TECH LIBRARY KAFB, NM
0067082

NATIONAL ADVISORY COMMITTEE FOR AERONAUTICS

TECHNICAL NOTE 4175

INVESTIGATION OF DEFLECTORS AS GUST ALLEVIATORS ON
A 0.09-SCALE MODEL OF THE BELL X-5 AIRPLANE WITH
VARIOUS WING SWEEP ANGLES FROM 20° TO 60° AT
MACH NUMBERS FROM 0.40 TO 0.90

By Delwin R. Croom and Jarrett K. Huffman

Langley Aeronautical Laboratory
Langley Field, Va.



Washington
November 1957

AFM-C
TECHNICAL LIBRARY
0067082



0067082

NATIONAL ADVISORY COMMITTEE FOR AERONAUTICS

TECHNICAL NOTE 4175

INVESTIGATION OF DEFLECTORS AS GUST ALLEVIATORS ON
A 0.09-SCALE MODEL OF THE BELL X-5 AIRPLANE WITH
VARIOUS WING SWEEP ANGLES FROM 20° TO 60° AT
MACH NUMBERS FROM 0.40 TO 0.90

By Delwin R. Croom and Jarrett K. Huffman

SUMMARY

An investigation was made in the Langley high-speed 7- by 10-foot tunnel to determine the effectiveness of a given deflector arrangement as a gust alleviator on a 0.09-scale model of the Bell X-5 airplane with various wing sweep angles from 20° to 60° at Mach numbers from 0.40 to 0.90 over a maximum angle-of-attack range from approximately -5° to 21°.

Deflectors were effective as gust alleviators (reduction of the lift-curve slope measured through 0° angle of attack) at all wing sweep angles; however, the magnitude of lift-curve-slope reduction varied with Mach number and wing sweep angle. For this particular deflector installation (projection of 15 percent average chord and span of 0.25 wing semispan located along the 35-percent-chord line of the unswept wing), the configuration with 50° swept wings had the maximum reduction in lift-curve slope and the minimum variation with Mach number (from approximately 29 percent at a Mach number of 0.40 to approximately 21 percent at a Mach number of 0.90). The deflectors caused an increase in drag at all Mach numbers and wing sweep angles of this investigation and, consequently, would be effective as aerodynamic brakes.

At the lower angles of attack (linear portion of the lift curve), the longitudinal stability of the wing configurations for angles of sweep from 20° to 50° was increased by the addition of the deflectors. At higher angles of attack as the Mach number was increased, pitch-up was evident for both the basic model and the model with deflectors. The severity of the pitch-up and the angle of attack when the pitch-up occurs are closely associated with the nonlinearity of the lift curve. Over the angle-of-attack range of the present investigation the deflectors caused no marked effect on the longitudinal stability of the 60° swept-wing model. It appears that, generally, if the basic model had no pitch-up problem, the deflectors did not cause pitch-up; however, if the basic model had pitch-up, the deflectors tended to increase pitch-up.

INTRODUCTION

A previous investigation made in the Langley 300-MPH 7- by 10-foot tunnel and in the Langley gust tunnel has shown that spoilers and deflectors (deflectors defined as lower-surface spoilers), when mounted near the leading edge of the unswept wing of a transport-airplane model, were effective in reducing the normal acceleration due to gusts. (See ref. 1.) As was pointed out in reference 1, this reduction in normal acceleration is proportional to the reduction in lift-curve slope due to addition of the spoilers or deflectors. It was anticipated that this type of control would be extended when rough air was encountered and remain extended as long as the aircraft was flying in rough air. The investigation was extended to include spoilers and deflectors on a 1/4-scale model of the Bell X-5 research airplane with 35° swept wings and on a high-aspect-ratio 35° swept-wing-fuselage model in the Langley 300-MPH 7- by 10-foot tunnel (ref. 2) and, also, on a 35° swept wing on the transonic bump in the Langley high-speed 7- by 10-foot tunnel (ref. 3). In each of these investigations the results indicated that these controls were effective in reducing the lift-curve slope; however, the data did not show the effect of varying wing sweep on the lift-curve-slope-reduction capabilities of spoilers or deflectors at the higher Mach numbers.

The purpose of the present investigation is to determine the effects of wing sweep and Mach number on the gust-alleviation capabilities of a given deflector arrangement on a 0.09-scale model of the Bell X-5 airplane. The deflector investigated had a projection of 15 percent of the average wing chord and a span of 25 percent of the wing semispan along the 35-percent-chord line of the unswept wing. The results are presented and discussed in terms of the reduction in lift-curve slope achieved through use of the deflector and the associated effects on the longitudinal stability and drag characteristics of the model.

SYMBOLS

All data are presented with respect to the wind axes. The pitching-moment coefficients are referred to a point 0.421 inch below the quarter chord of the mean aerodynamic chord. (This vertical position corresponds to the vertical position of the center of gravity of the airplane.)

b	wing span, ft
b _t	span of horizontal tail, ft
C _D	drag coefficient, $\frac{\text{Drag}}{qS}$

C_L	lift coefficient, $\frac{\text{Lift}}{qS}$
$C_{L_{\alpha,0}}$	slope of lift curve of basic model (measured at $\alpha = 0^\circ$), per deg
$C_{L_{\alpha,D}}$	slope of lift curve of model with deflector (measured at $\alpha = 0^\circ$), per deg
C_m	pitching-moment coefficient, $\frac{\text{Pitching moment}}{qS\bar{c}}$
c	local wing chord, ft
\bar{c}	wing mean aerodynamic chord, $\frac{2}{S} \int_0^{b/2} c^2 dy$, ft
c_{av}	average streamwise wing chord spanned by control, ft
c_r	wing root chord, ft
$c_{\Lambda=0^\circ}$	wing chord measured perpendicular to 38.02-percent-chord line of unswept wing, ft
M	Mach number
q	dynamic pressure, $\frac{\rho V^2}{2}$, lb/sq ft
R	Reynolds number, based on \bar{c}
S	wing area, sq ft
V	free-stream velocity, ft/sec
x	longitudinal distance, ft
y	lateral distance, ft
α	angle of attack, deg
Λ	angle of sweep of wing, deg
ρ	mass density of air, slugs/cu ft

MODEL AND APPARATUS

The model used for the present investigation was a 0.09-scale steel model of the Bell X-5 research airplane and was supplied to the National Advisory Committee for Aeronautics by the Bell Aircraft Corporation. The wing angle of sweep of the X-5 airplane is variable in flight from 20° to 60° , and longitudinal translation of the wing with respect to the fuselage occurs as the angle of sweep varies.

In this investigation the angle of sweep of the model wing was varied from 20° to 60° . The wing was equipped with deflectors mounted along the 35-percent-chord line of the unswept wing. The deflector had a projection of 15 percent of the average wing chord and a span of $0.25b/2$ with the inboard end the same distance from the plane of symmetry as the tip of the horizontal tail. A three-view drawing of the model, the physical characteristics of the model, and the deflector installation are shown in figure 1.

The model was supported in the Langley high-speed 7- by 10-foot tunnel by means of a sting-support system and was attached to the sting support through a six-component internal strain-gage balance. The model was rotated in pitch so that it was kept reasonably close to the tunnel center line. Because the sting support was used, modifications to the model at the rear end of the fuselage were necessary. The horizontal-tail and vertical-tail surfaces on the model, therefore, are slightly different from those on the full-scale airplane. A comparison of the modified fuselage and empennage of the model with the fuselage and empennage of the full-scale airplane is presented in figure 1(a).

TESTS

The sting-supported model was tested in the Langley high-speed 7- by 10-foot tunnel at Mach numbers ranging from 0.40 to 0.90 and at angles of attack ranging from about -5° to 21° except when the load limit of the strain-gage balance would have been exceeded. The Reynolds number, based on the wing mean aerodynamic chord, varied with Mach number and wing sweep from about 1.3×10^6 to 3.8×10^6 as is shown in figure 2. Tests were made with and without the deflector installed at wing angles of sweep of 20° , 35° , 45° , 50° , and 60° . The angle of incidence of the horizontal tail was -1.7° for all tests.

CORRECTIONS

Blockage corrections were applied to the results by the method of reference 4. Jet-boundary corrections to the angle of attack, drag, and pitching moment were applied in accordance with reference 5.

Model support tares have not been applied except for a fuselage base pressure to the drag. The corrected drag data represent a condition of free-stream static pressure at the fuselage base. From past experience, it is expected that the influence of the sting support on the model characteristics is negligible with regard to the lift and pitching moment.

The angle of attack has been corrected for deflection of the balance and sting support.

RESULTS AND DISCUSSION

The lift, drag, and pitching-moment coefficients for both the basic model and the model equipped with deflectors are presented as a function of angle of attack in figures 3, 4, and 5, respectively. (In order to facilitate presentation of the data, staggered scales have been used in these figures and care should be taken in identifying the zero axis for each curve.) A summary plot of the lift-curve slopes $C_{L_{\alpha,0}}$ and $C_{L_{\alpha,D}}$ (measured at $\alpha = 0^\circ$) as a function of Mach number is presented in figure 6. The variation of percent lift-curve-slope reduction due to the deflector as a function of sweep angle and of Mach number is presented in figure 7.

The deflector arrangement used on the test model (projection of 15 percent of average chord and span of $0.25b/2$ located along the 35-percent-chord line of the unswept wing) effected a reduction in the lift-curve slope; however, the magnitude of reduction varied with Mach number and wing sweep angle. (See figs. 6 and 7.) An increase in effectiveness (reduction in lift-curve slope due to deflector) was observed as the wing sweep angle was increased up to about 50° , and above an angle of sweep of 50° the effectiveness decreased. A decrease in effectiveness was noted with increased Mach number for all angles of sweep of this investigation with the exception of the 60° swept wing which showed the reverse trend up to a Mach number of about 0.80. At an angle of sweep of 50° the reduction in lift-curve slope was at a maximum and the variation of lift-curve-slope reduction with Mach number was at a minimum (from approximately 29 percent at $M = 0.40$ to approximately 21 percent at $M = 0.90$). Even though no attempt was made to install the deflectors at the optimum chordwise position, it is indicated from these

results that a deflector can be used as a gust-alleviation device on swept wings. It should be noted, however, that, when deflectors were installed on the wings, the lift curves tended to become more nonlinear except for the 60° swept wing (fig. 3), and in some cases the deflector caused a relatively sharp break in the lift curve which could result in unwanted roll-off characteristics. Over the linear lift-curve range, when the deflectors were extended, the maximum change in attitude (change in angle of attack) at a given lift coefficient was of the order of 4° .

The drag of the model was increased by the addition of the deflectors at all angles of sweep and Mach numbers. This increase in drag indicates that deflectors would be effective as aerodynamic brakes and would aid in slowing down the airplane to "rough air" speed. (See fig. 4.)

At the lower angles of attack (linear portion of the lift curve), the longitudinal stability of the wing configurations for $\Lambda = 20^\circ$ to $\Lambda = 50^\circ$ was increased by the addition of the deflectors, and it is possible that there would be large trim changes (fig. 5). However, at higher angles of attack as the Mach number was increased, pitch-up was evident for both the basic model and the deflector model. The severity of the pitch-up and the angle of attack when the pitch-up occurs are closely associated with the nonlinearity of the lift curve. Although the deflector had no marked effect on the longitudinal stability of the 60° swept-wing model and no pitch-up was evident, it should be pointed out that a previous investigation which extended to higher angles of attack did show pitch-up tendencies (ref. 6) and it is likely that, had the present investigation extended to higher angles of attack, pitch-up tendencies would have been evident for both the basic model and the deflector model.

From results of the present investigation and the investigations of references 1 to 3, it appears that, generally, for basic models that had no pitch-up problems the deflectors did not cause pitch-up; however, if the basic model had pitch-up, the deflectors tended to increase pitch-up and, in some cases, caused pitch-up at a lower angle of attack.

CONCLUDING REMARKS

Results have been presented of an investigation in the Langley high-speed 7- by 10-foot tunnel to determine the effectiveness of deflectors as gust alleviators on a 0.09-scale model of the Bell X-5 airplane at various wing sweep angles.

Deflectors were effective as gust alleviators (reduction of the lift-curve slope measured through 0° angle of attack) at all wing sweep angles; however, the magnitude of lift-curve-slope reduction varied with Mach number and wing sweep angle. For the test installation the configuration with the 50° swept wing gave the maximum reduction in lift-curve slope and the minimum variation with Mach number (from approximately 29 percent at a Mach number of 0.40 to approximately 21 percent at a Mach number of 0.90).

The deflectors caused an increase in drag at all Mach numbers and wing sweep angles of the tests and, therefore, would be effective as aerodynamic brakes.

At the lower angles of attack (linear portion of the lift curve), the longitudinal stability of the wing configurations for angles of sweep from 20° to 50° was increased by the addition of the deflectors. However, at higher angles of attack as the Mach number was increased, pitch-up was evident for both the basic model and the deflector model. The severity of the pitch-up and the angle of attack when the pitch-up occurs are closely associated with the nonlinearity of the lift curve. Over the angle-of-attack range of the present investigation the deflector caused no marked effect on the longitudinal stability of the 60° swept-wing model. It appears that, generally, if the basic model had no pitch-up problem, the deflectors did not cause pitch-up; however, if the basic model had pitch-up, the deflectors tended to increase pitch-up.

Langley Aeronautical Laboratory,
National Advisory Committee for Aeronautics,
Langley Field, Va., September 9, 1957.

REFERENCES

1. Croom, Delwin R., Shufflebarger, C. C., and Huffman, Jarrett K.: An Investigation of Forward-Located Fixed Spoilers and Deflectors as Gust Alleviators on an Unswept-Wing Model. NACA TN 3705, 1956.
2. Croom, Delwin R., and Huffman, Jarrett K.: Investigation at Low Speeds of Deflectors and Spoilers as Gust Alleviators on a Model of the Bell X-5 Airplane With 35° Swept Wings and on a High-Aspect-Ratio 35° Swept-Wing—Fuselage Model. NACA TN 4057, 1957.
3. Croom, Delwin R., and Huffman, Jarrett K.: Investigation at Transonic Speeds of Deflectors and Spoilers as Gust Alleviators on a 35° Swept Wing - Transonic-Bump Method. NACA TN 4006, 1957.
4. Herriot, John G.: Blockage Corrections for Three-Dimensional-Flow Closed-Throat Wind Tunnels With Consideration of the Effect of Compressibility. NACA Rep. 995, 1950. (Supersedes NACA RM A7B28.)
5. Gillis, Clarence L., Polhamus, Edward C., and Gray, Joseph L., Jr.: Charts for Determining Jet-Boundary Corrections for Complete Models in 7- by 10-Foot Closed Rectangular Wind Tunnels. NACA WR L-123, 1945. (Formerly NACA ARR L5G31.)
6. Bielat, Ralph P., and Campbell, George S.: A Transonic Wind-Tunnel Investigation of the Longitudinal Stability and Control Characteristics of a 0.09-Scale Model of the Bell X-5 Research Airplane and Comparison With Flight. NACA RM L53H18, 1953.

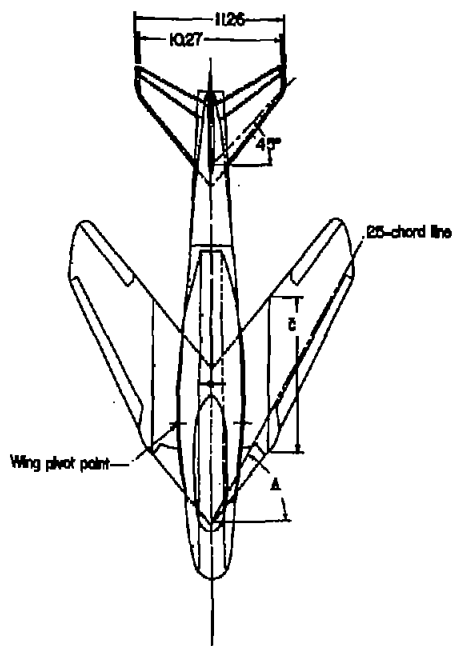

PHYSICAL CHARACTERISTICS OF MODEL

Wing: Airfoil section perpendicular to 25.05-percent-chord line

Free point	NACA 64(10)A011				
Tip	NACA 64(00)A008.58				
Sweep, deg	20	25	45	50	60
Span, ft	1.888	1.838	2.315	2.089	1.978
Area, sq ft	1.363	1.361	1.417	1.444	1.553
Aspect ratio	8.91	4.93	2.48	2.38	2.01
Taper ratio	0.441	0.449	0.488	0.480	0.454
\bar{x} , ft	0.512	0.584	0.678	0.743	0.808
Incidence, deg	0	0	0	0	0
Dihedral, deg	0	0	0	0	0
Geometric twist, deg	0	0	0	0	0
x , ft	1.171	1.184	1.194	1.209	0.978

Horizontal lift:
 Airfoil section parallel to plane of symmetry NACA 64A008
 Area, sq ft 0.384
 Aspect ratio 2.94
 Incidence, deg -1.7

Vertical lift:
 Airfoil section parallel to aft fuselage center line NACA 64A008
 Area, sq ft 0.235
 Aspect ratio 1.81

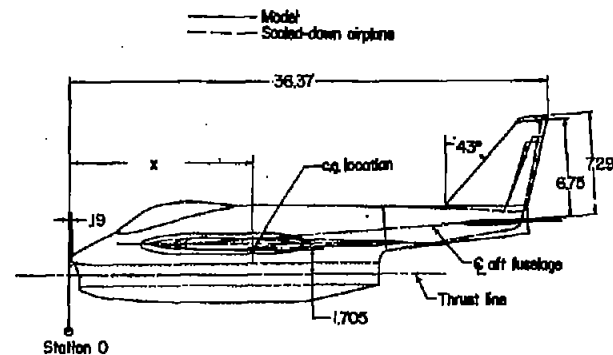
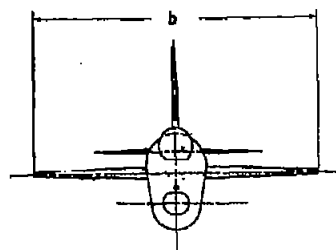

(a) Three-view drawing of model.

Figure 1.- General arrangement of test model. All dimensions are in inches unless otherwise indicated.

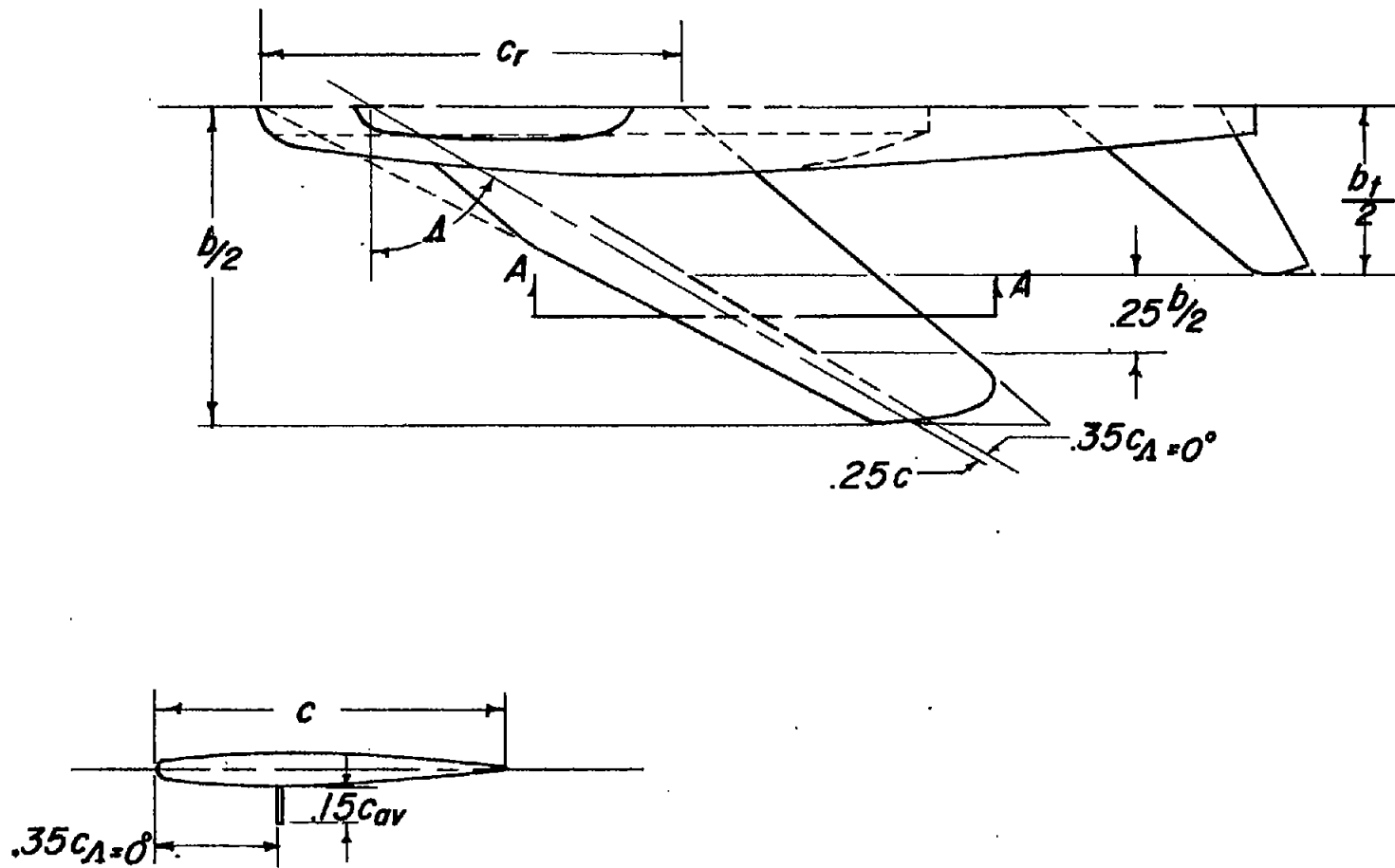

Typical deflector section A-A

(b) Detail of deflector installations.

Figure 1.- Concluded.

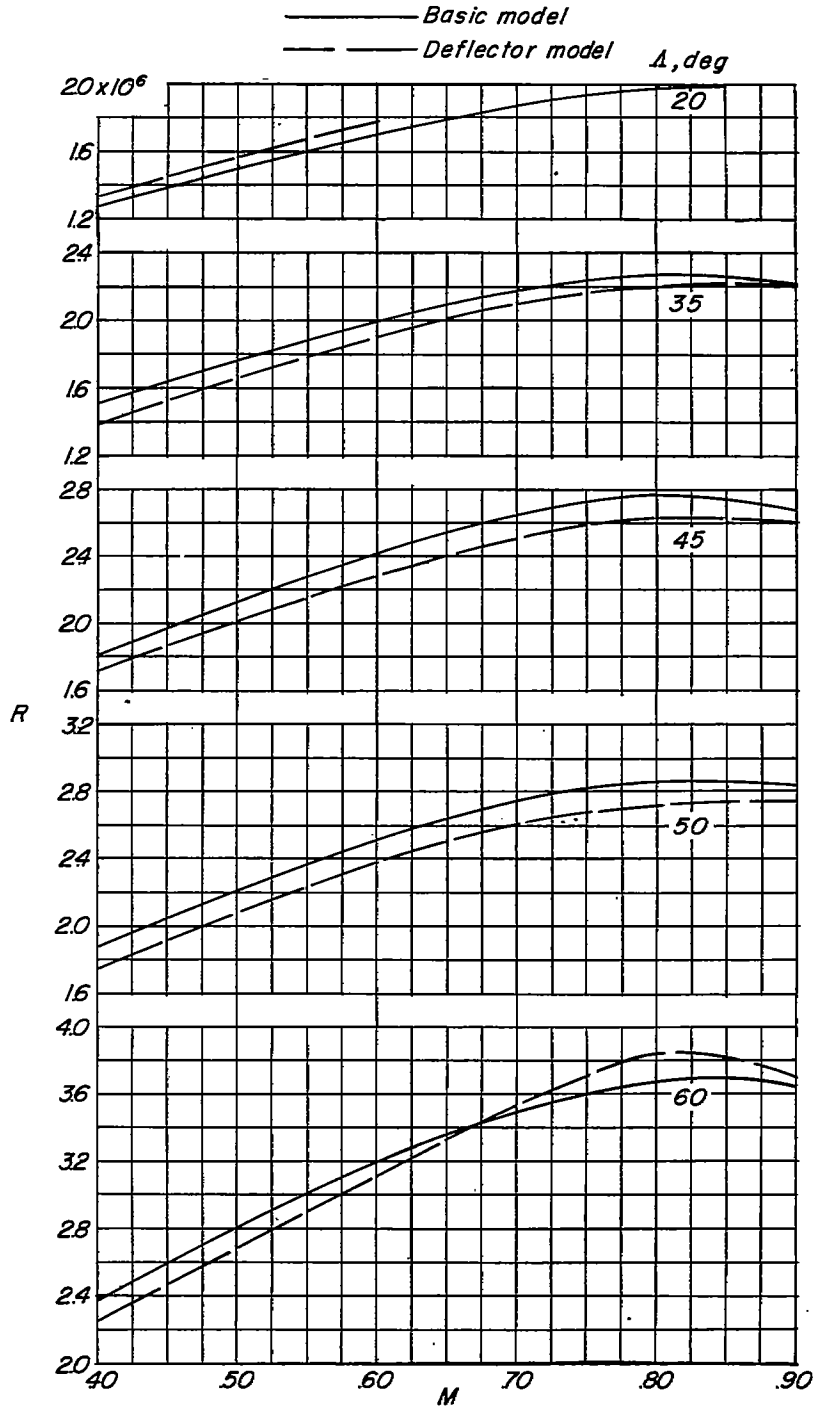
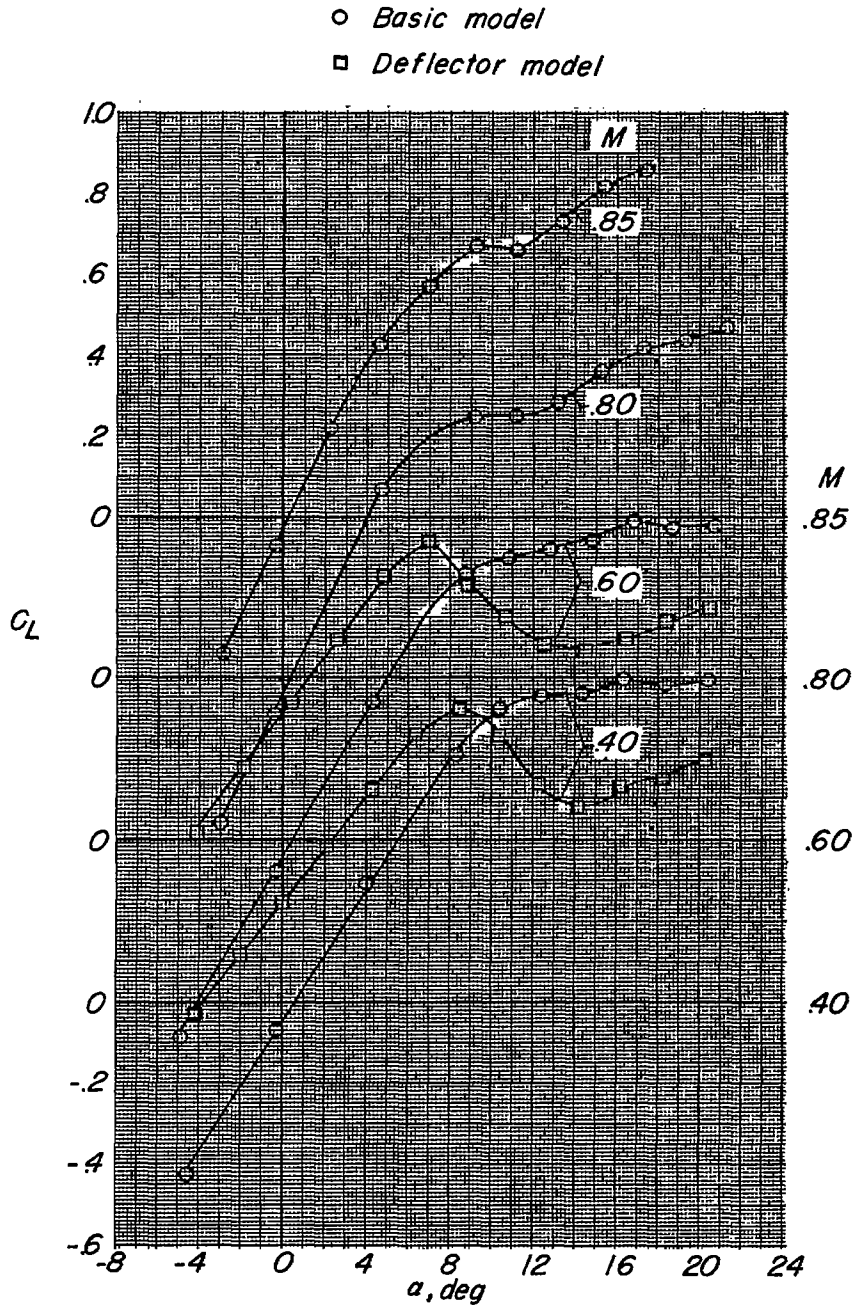
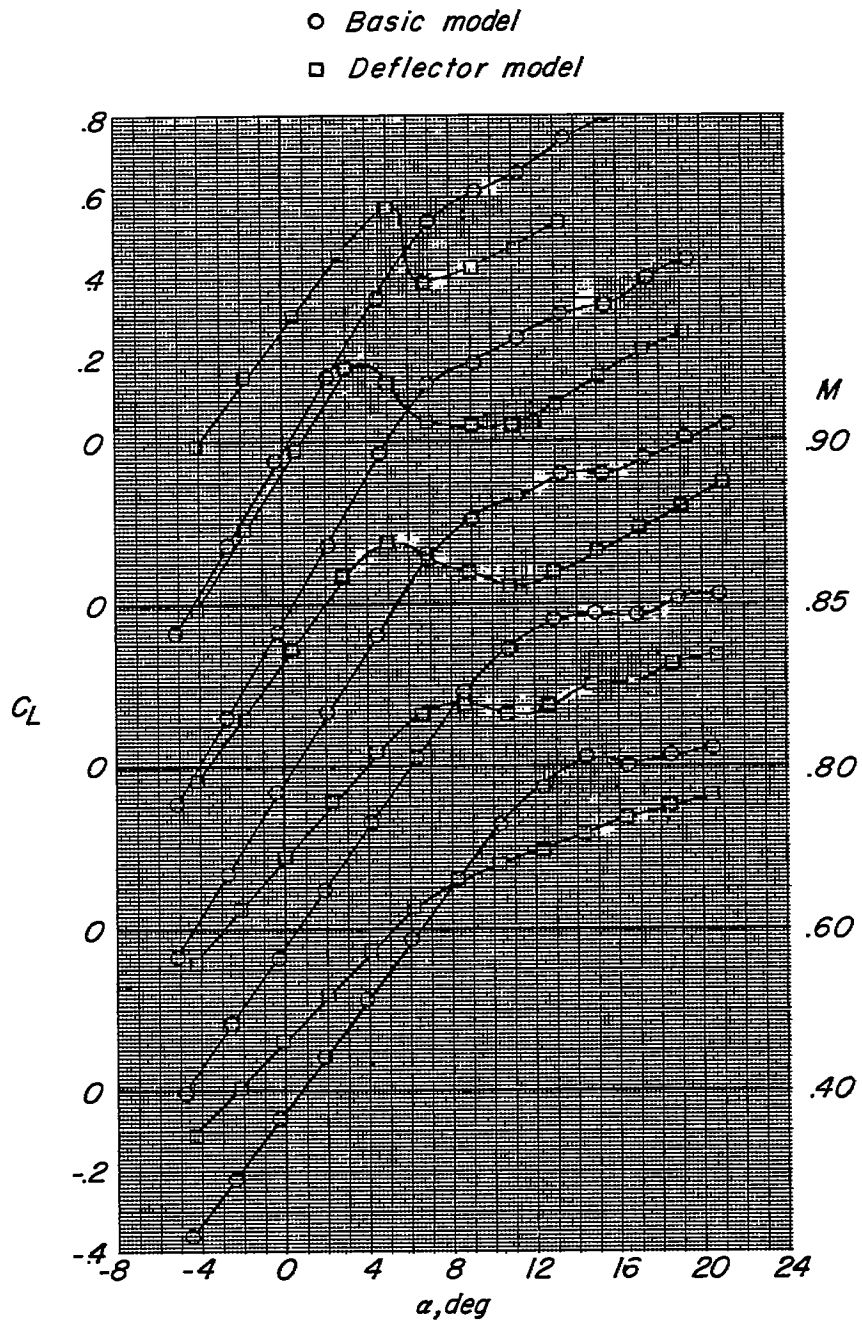

Figure 2.- Variation with Mach number of test Reynolds number based on wing mean aerodynamic chord.



(a) $\Lambda = 20^\circ$.

Figure 3.- Variation of lift coefficient with angle of attack at several Mach numbers for the basic model and the model equipped with deflectors.



(b) $\Lambda = 35^\circ$.

Figure 3.- Continued.

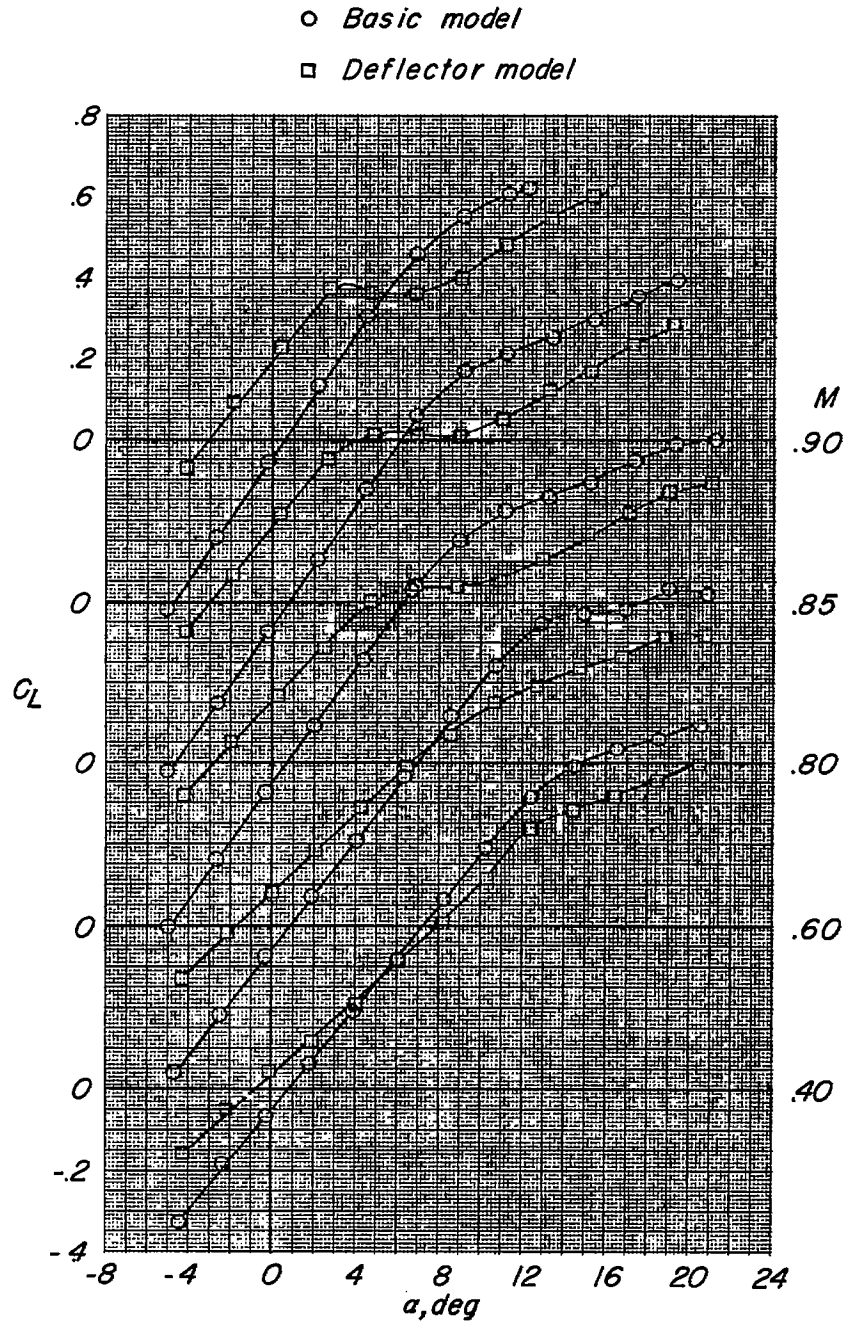

(c) $\Lambda = 45^\circ$.

Figure 3.- Continued.

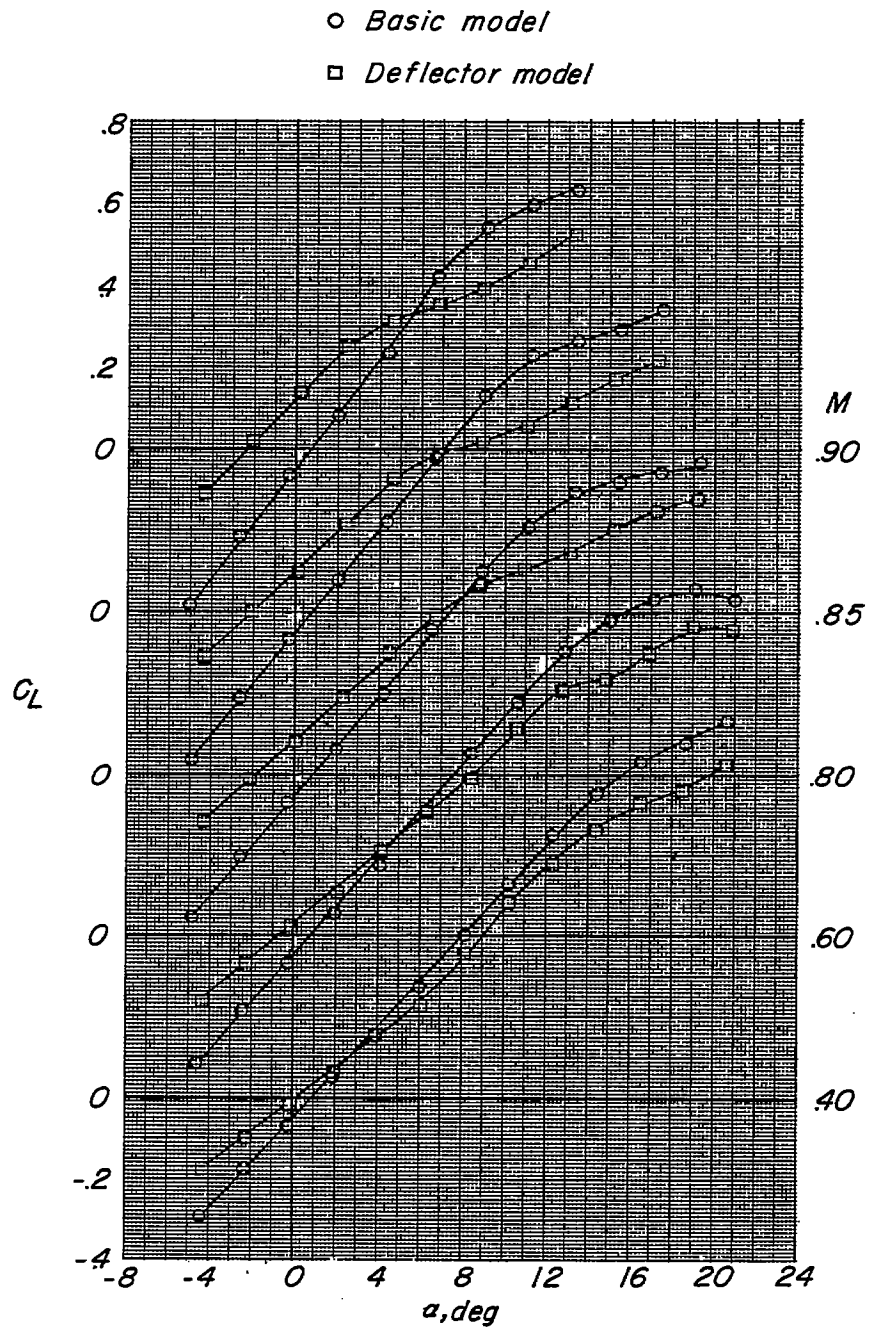

(d) $\Lambda = 50^\circ$.

Figure 3.- Continued.

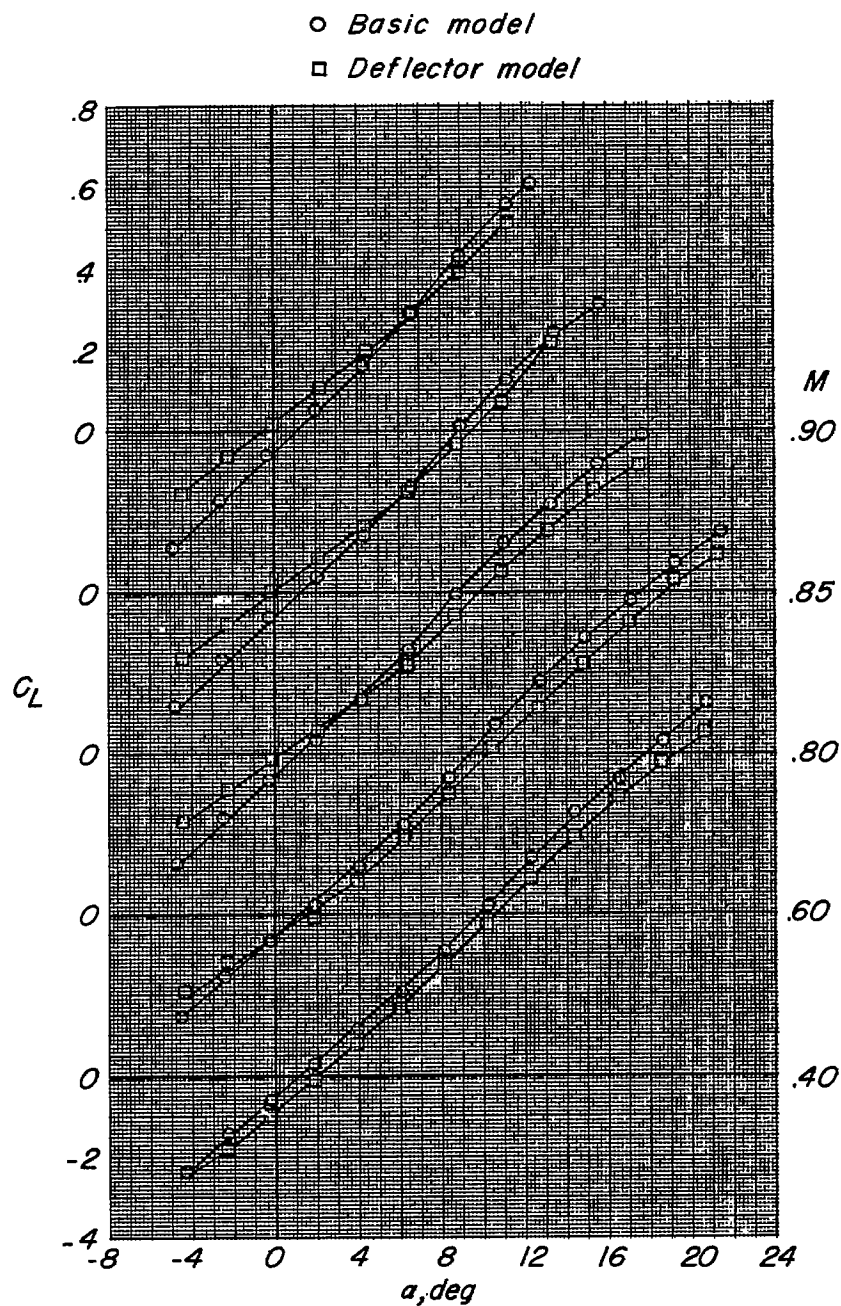

(e) $\Lambda = 60^\circ$.

Figure 3.- Concluded.

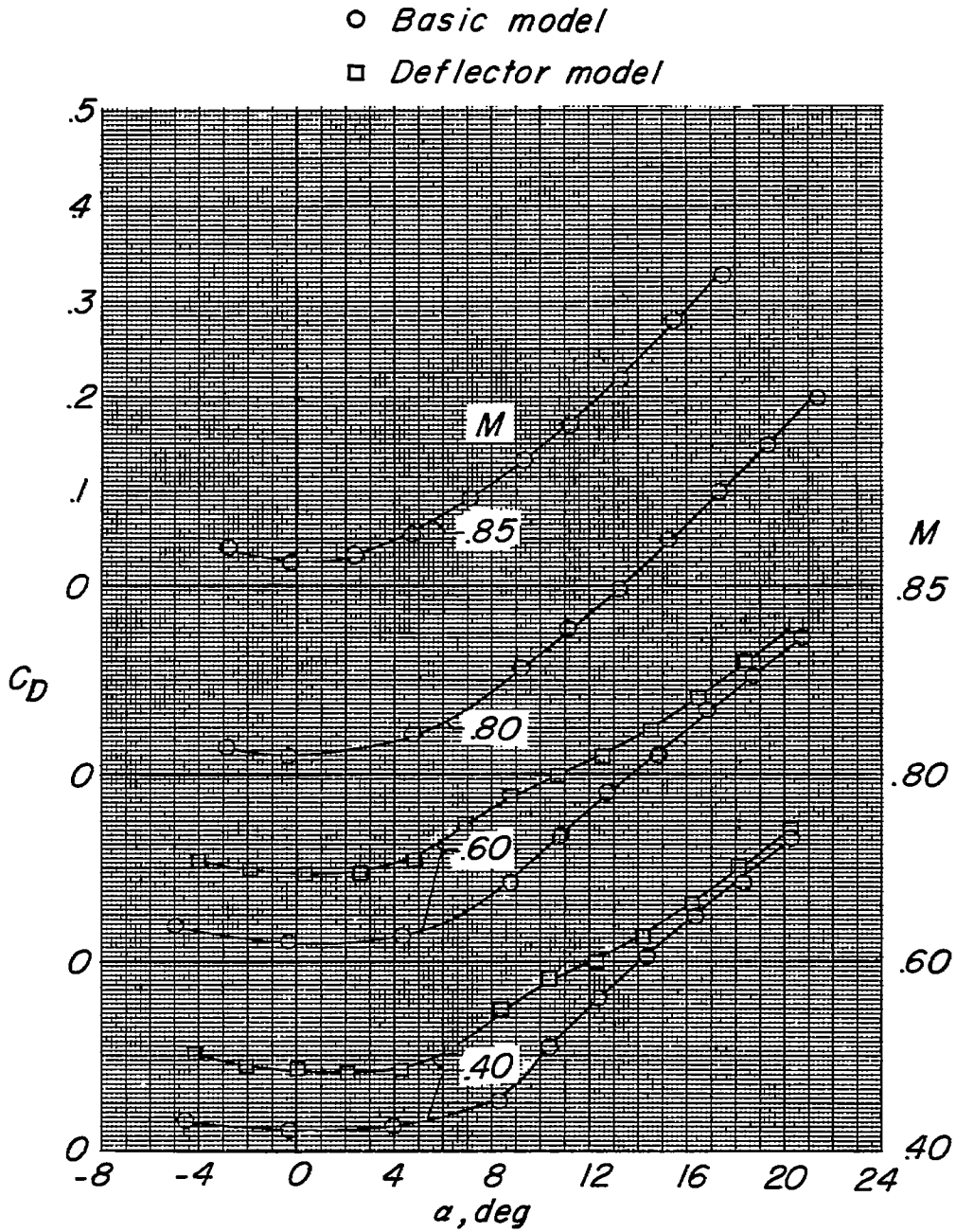

(a) $\Lambda = 20^\circ$.

Figure 4.- Variation of drag coefficient with angle of attack at several Mach numbers for the basic model and the model equipped with deflectors.

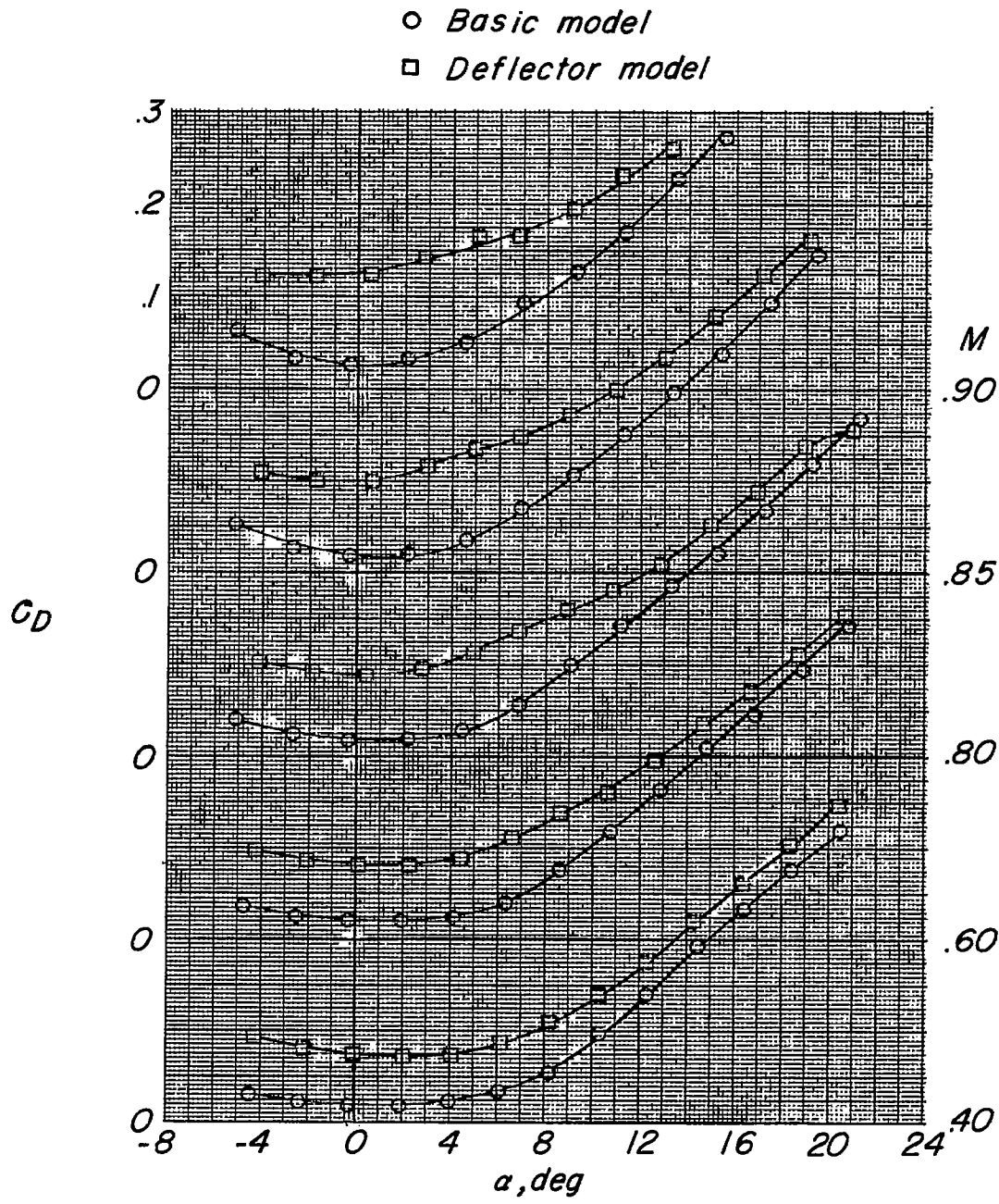

(b) $\Lambda = 35^\circ$.

Figure 4.- Continued.

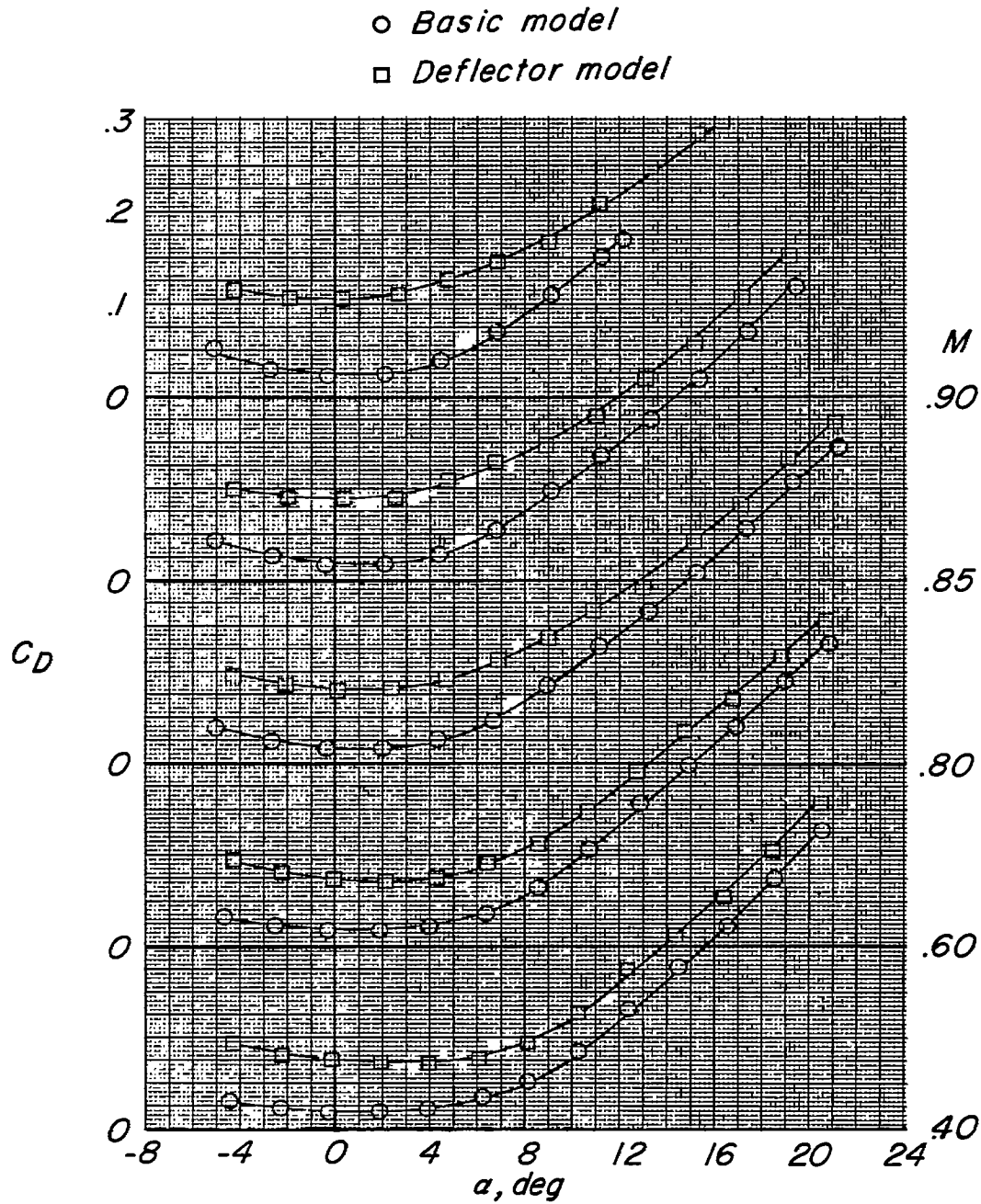

(c) $\Lambda = 45^\circ$.

Figure 4.- Continued.

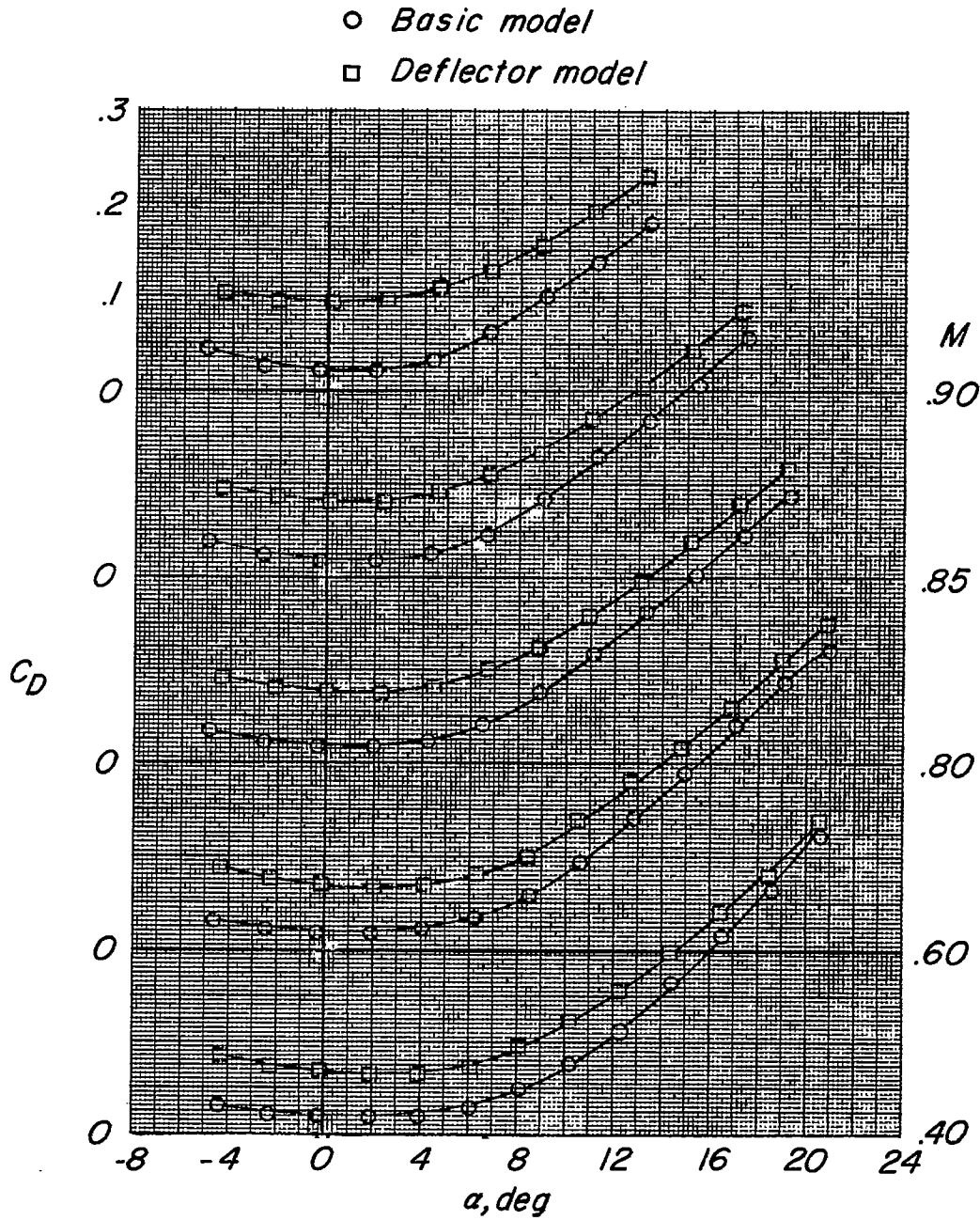

(a) $\Lambda = 50^\circ$.

Figure 4.- Continued.

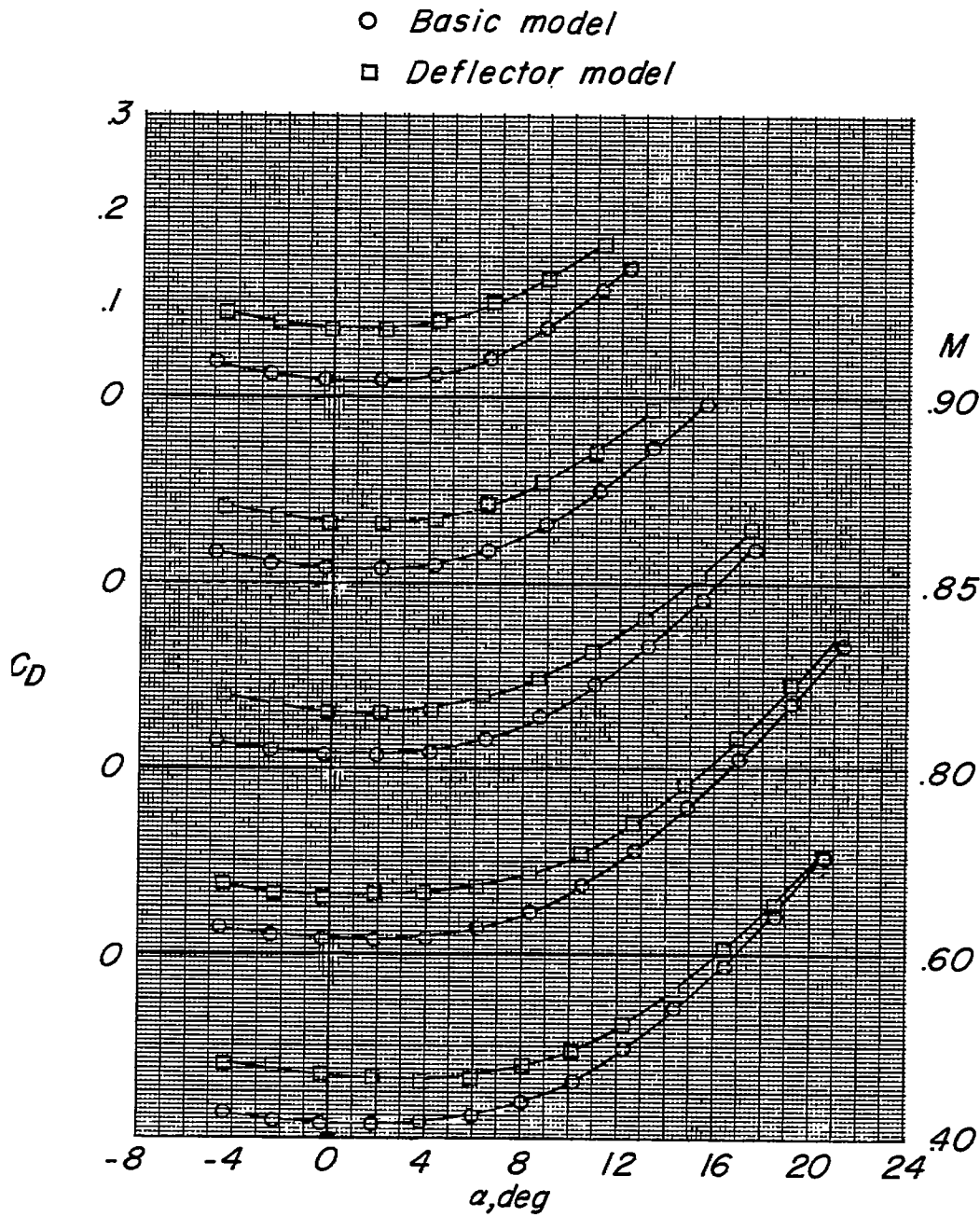

(e) $\Lambda = 60^\circ$.

Figure 4.- Concluded.

○ *Basic model*
 □ *Deflector model*

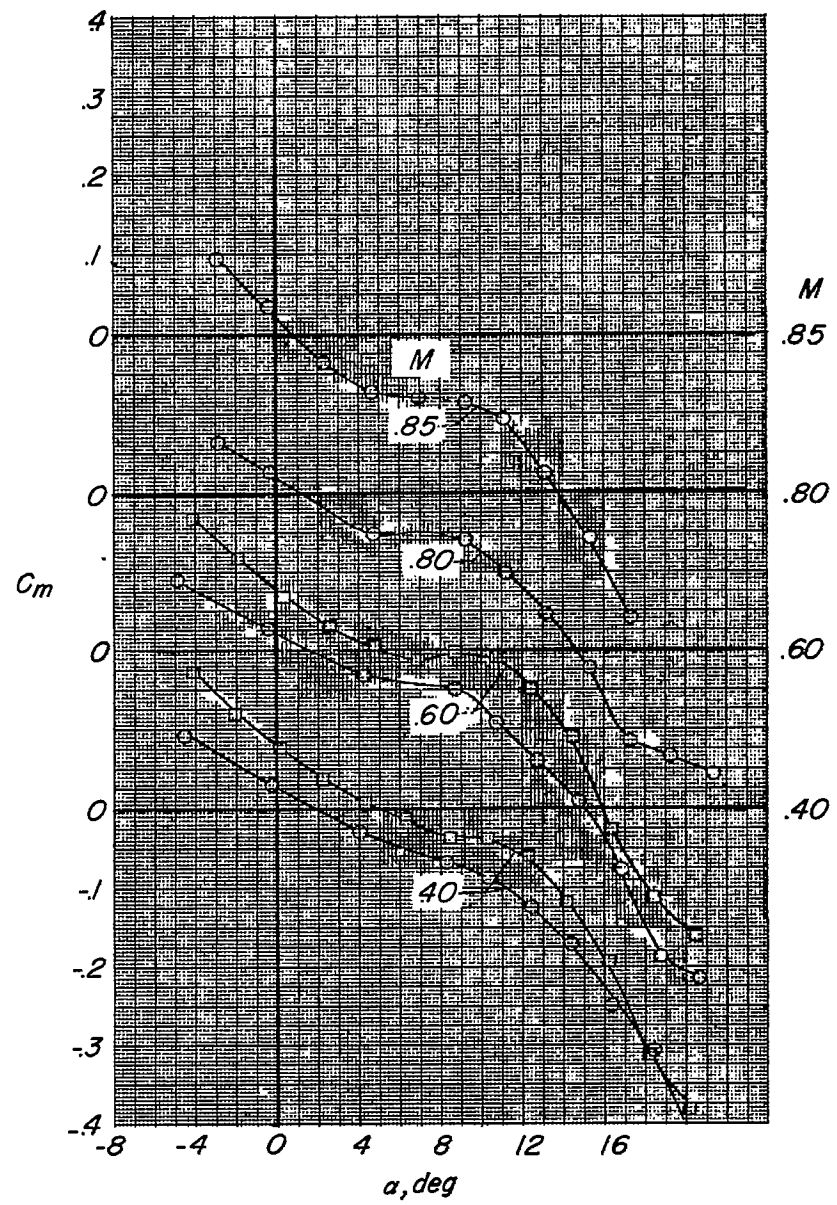

(a) $\Lambda = 20^\circ$.

Figure 5.- Variation of pitching-moment coefficient with angle of attack at several Mach numbers for the basic model and the model equipped with deflectors.

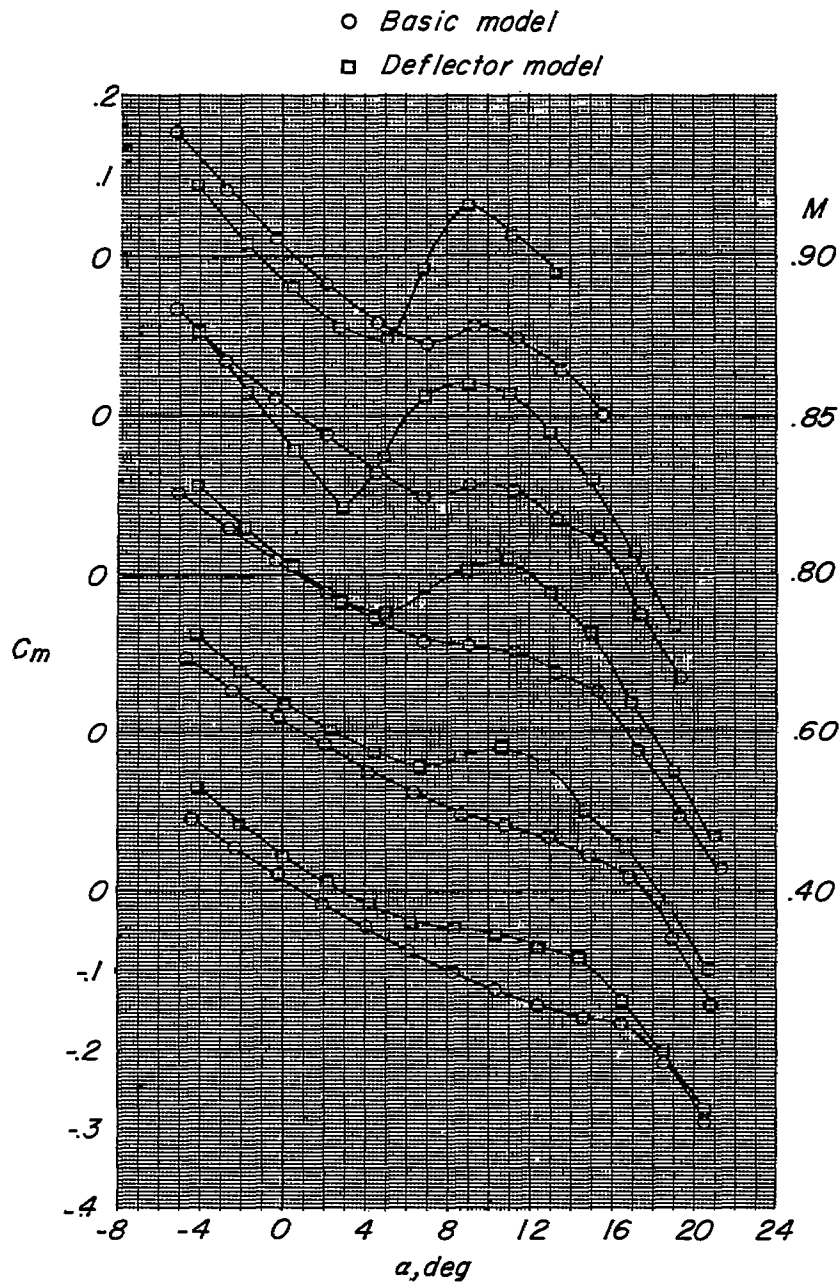

(b) $\Lambda = 35^\circ$.

Figure 5.- Continued.

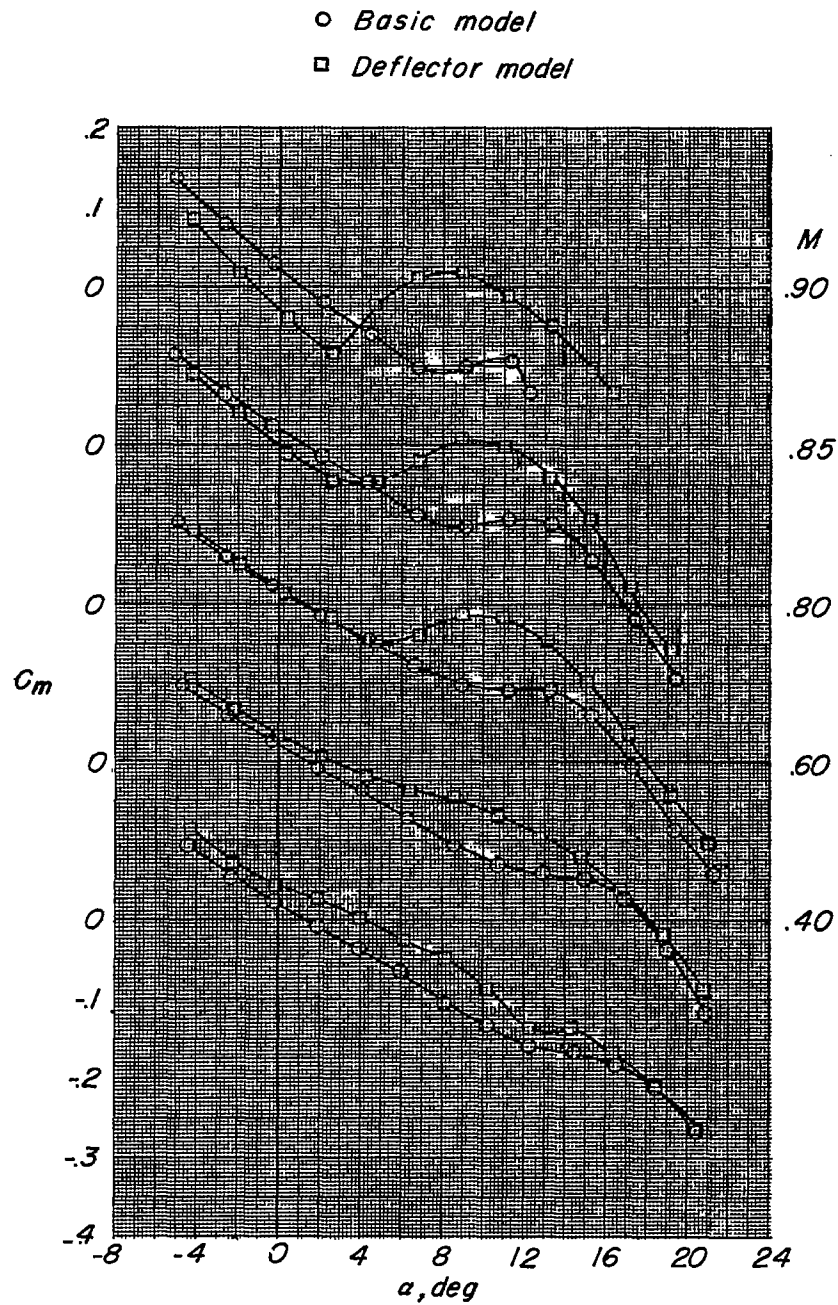

(c) $\Lambda = 45^\circ$.

Figure 5.- Continued.

○ *Basic model*
□ *Deflector model*

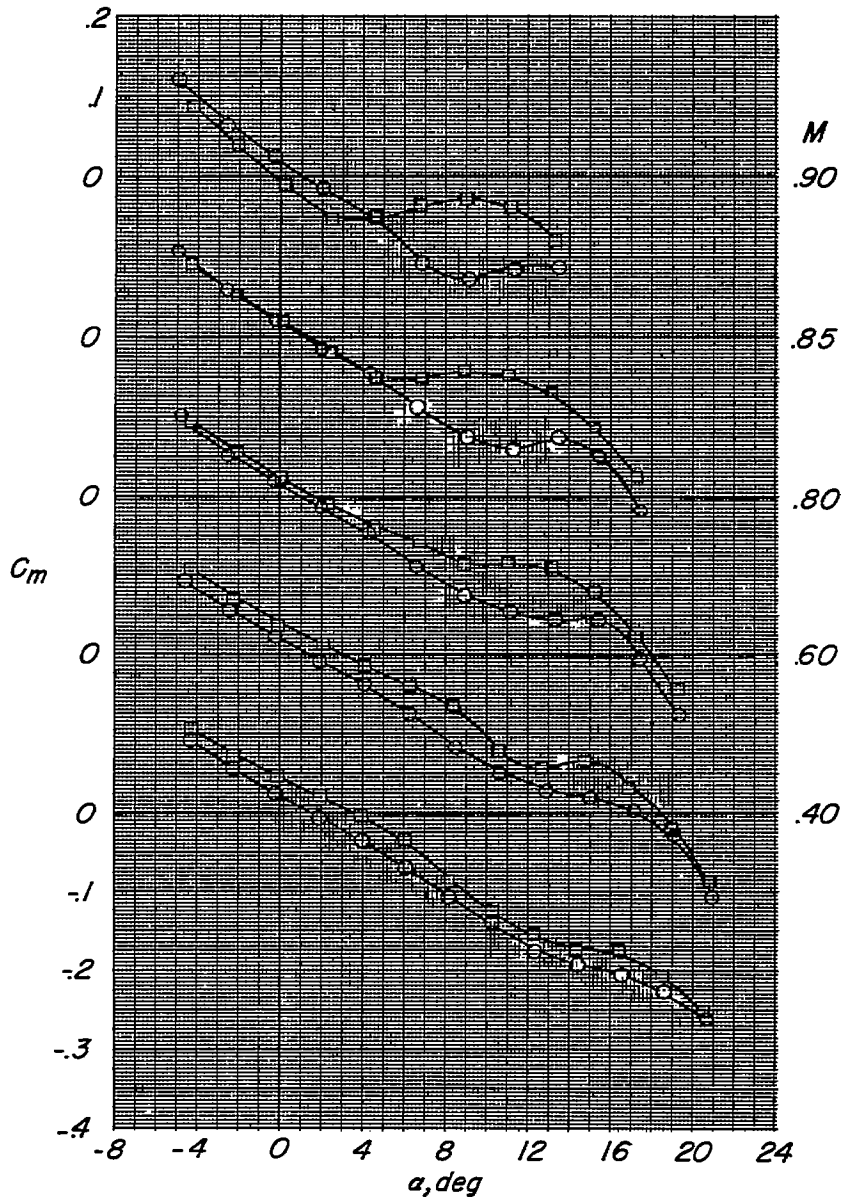

(d) $\Lambda = 50^\circ$.

Figure 5.- Continued.

○ *Basic model*
□ *Deflector model*

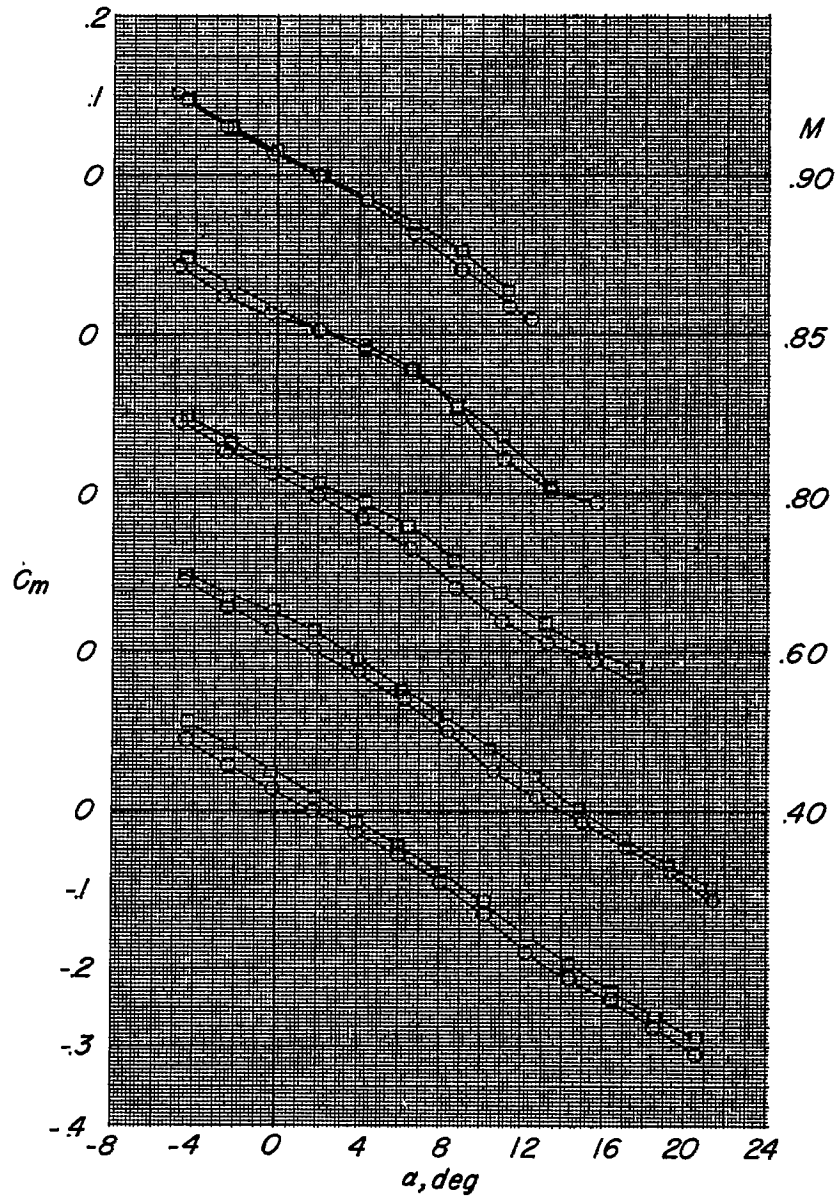

(e) $\Lambda = 60^\circ$.

Figure 5.- Concluded.

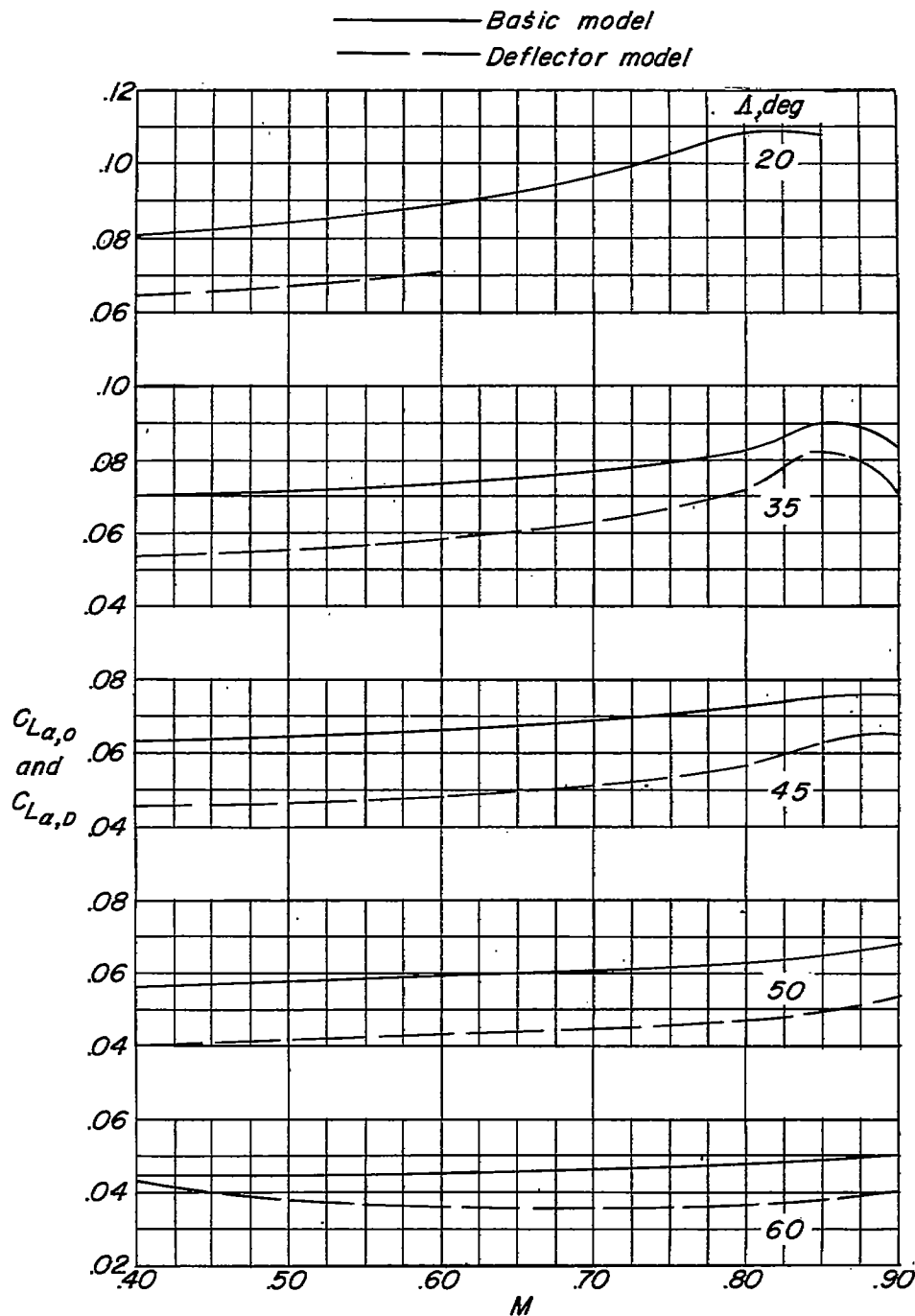
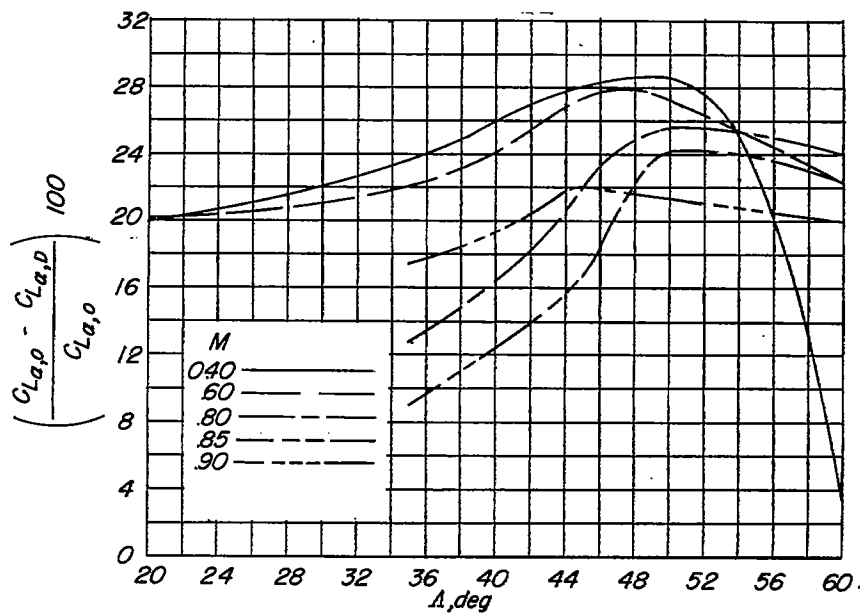
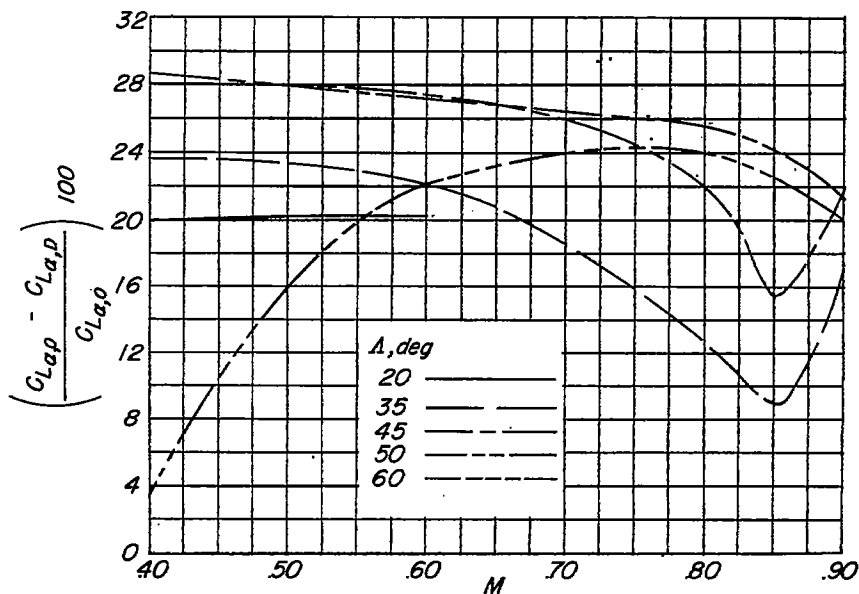

Figure 6.- Variation of lift-curve slope with Mach number for the basic model and the model equipped with deflectors (slopes measured at $\alpha = 0^\circ$).



(a) Percent lift-curve-slope reduction as a function of wing sweep.



(b) Percent lift-curve-slope reduction as a function of Mach number.

Figure 7.- Variation of percent lift-curve-slope reduction with wing sweep and Mach number.