

RECEIVED
MAY 8 1934

MAY 11 1934

[Handwritten scribbles and markings]

Library L. M. A. L.

TECHNICAL NOTES

NATIONAL ADVISORY COMMITTEE FOR AERONAUTICS

No. 497

FULL-SCALE DRAG TESTS OF LANDING LAMPS

By G. H. Dearborn
Langley Memorial Aeronautical Laboratory

Washington
May 1934

NATIONAL ADVISORY COMMITTEE FOR AERONAUTICS

TECHNICAL NOTE NO. 497

FULL-SCALE DRAG TESTS OF LANDING LAMPS

By C. H. Dearborn

SUMMARY

Drag tests were conducted in the N.A.C.A. full-scale wind tunnel on full-scale models of two Army Air Corps type A-6 landing lamps mounted on an 8 by 48 foot airfoil. Drag measurements were made with the lamps in the leading edge and attached to the lower surface at the 5 and 10 percent chord positions. The drag of the lamps when faired into the airfoil was also measured.

The results show that at 100 miles per hour and at the angle of minimum drag of the airfoil the unfaired lamps in the leading edge produced an increase in drag of 5.5 pounds and that the unfaired lamps on the lower surface at either position increased the airfoil drag 22.5 pounds. These increases represent 6 and 24 percent of the minimum drag of the airfoil, respectively. Fairing the lamps into the airfoil reduced the drag of the lamps about 50 percent for the leading-edge position and about 60 percent for the two lower surface positions.

INTRODUCTION

With the rapid increase being made in the speed of modern transport and military airplanes, greater attention is being given by airplane designers to the effect of various types of wing protuberances. The National Advisory Committee for Aeronautics has conducted several investigations to study this effect. (See references 1 to 5.)

The investigation reported herein was requested by the Bureau of Aeronautics, Navy Department, to determine the drag of the Army Air Corps type A-6 landing lamp located in the leading edge and upon the lower surface of a wing. The tests were conducted in the N.A.C.A. full-scale wind tunnel with the lamps mounted on an 8 by 48 foot airfoil.

APPARATUS AND TESTS

Two dummy wooden lamps were constructed to the dimensions of the Army Air Corps type A-6 landing lamp (fig. 1) and cylindrical wooden fairings were made for fairing the lamps into the airfoil at three locations (fig. 2). A smooth metal-covered 8 by 48 foot Clark Y airfoil was used. The tests were conducted in the full-scale wind tunnel described in reference 6.

The drag of the plain airfoil was determined first; the two dummy lamps were then successively attached to the airfoil at the leading edge and at the 5 and 10 percent chord positions on the lower surface, and measurements made of the drag of the arrangement with the lamps in each position, both faired and unfaired. The lamps were placed 8 feet apart along the span with each lamp 6 feet from the nearest airfoil support to eliminate the possibility of interference effects. The axes of the lamps were set at -15° to the airfoil chord line to simulate the installation specified by the Army. This arrangement provides a horizontal axis of the lamps for a three-point landing. Photographs of one of the dummy lamps, both with and without fairing at the leading edge of the airfoil and on the lower surface at the 10 percent chord position, are presented in figure 3.

The plain airfoil and the airfoil with each lamp installation was tested at several air speeds between 50 and 104 miles per hour to determine the scale effect. For each velocity the angle of attack of the airfoil was varied between -7.5° and -1° in order to include the angle of minimum drag and the angle corresponding to the high-speed condition.

RESULTS AND DISCUSSION

No appreciable scale effect was apparent from the final results; hence, data are given for only one air speed - 100 miles per hour (standard conditions). The speed of the air stream changed slightly with angle of attack, therefore the measured results were plotted against air speed at each angle of attack and the points shown in figure 4 were taken from the faired curves.

The lamps faired into the leading edge produced the least increase in drag, 3 pounds at the minimum drag angle of the airfoil (about 3 percent of the airfoil drag). The drag added by the lamps faired into the lower surface of the airfoil was practically the same for either location throughout the angle-of-attack range of the tests and was about three times that of the lamps faired into the leading edge. A comparison of the drag curves for the faired and unfaired conditions shows that the fairings decreased the lamp drag about 50 percent for the leading-edge position and about 60 percent for the two lower surface positions at the angle of minimum drag for the airfoil. None of the lamp arrangements tested had a measurable effect on the lift of the airfoil.

The effect on the high speed of a typical airplane of the additional drag for the conditions investigated is illustrated in table I. The following assumptions were made: engine, 700 horsepower; propulsive efficiency, 85 percent; wing of Clark Y section with a chord of 8 feet at the span location of the lamps; and the top speed of the airplane, 200 miles per hour. A lift coefficient of 0.100 corresponding to the tunnel angle of attack of -3° was chosen for the high-speed condition.

CONCLUSION

The percentage increases in minimum drag obtained for the lamp arrangements investigated are smaller than would be obtained on many airplane wings due to the comparatively large airfoil used; however, the actual increases in drag would be applicable to similar installations in which the chord of the wing at the lamp location is the same as that of the airfoil used in the tests. The results indicate that the leading-edge position is the best location for landing lamps.

Langley Memorial Aeronautical Laboratory,
National Advisory Committee for Aeronautics,
Langley Field, Va., April 10, 1934.

REFERENCES

1. Jacobs, Eastman N.: Effect of Protruding Gasoline Tanks upon the Characteristics of an Airfoil. T.N. No. 249, N.A.C.A., 1926.
2. Hocker, Roy W.: The Aerodynamic Characteristics of Airfoils as Affected by Surface Roughness. T.N. No. 457, N.A.C.A., 1933.
3. Dearborn, Clinton H.: The Effect of Rivet Heads on the Characteristics of a 6 by 36 Foot Clark Y Metal Airfoil. T.N. No. 461, N.A.C.A., 1933.
4. Jacobs, Eastman N.: Airfoil Section Characteristics as Affected by Protuberances. T.R. No. 446, N.A.C.A., 1932.
5. Jacobs, Eastman N., and Sherman, Albert: Wing Characteristics as Affected by Protuberances of Short Span. T.R. No. 449, N.A.C.A., 1933.
6. DeFrance, Smith J.: The N.A.C.A. Full-Scale Wind Tunnel. T.R. No. 459, N.A.C.A., 1933.

TABLE I

Computed Decrease in the Speed of a Typical 200 m.p.h.
 Airplane for the Lamp Arrangements Tested

Lamp arrangement	Decrease in top speed, m.p.h.
Faired lamps at leading edge	0.5
Unfaired lamps at leading edge	1.0
Faired lamps on lower surface at 5 percent chord position	1.6
Unfaired lamps on lower surface at 5 percent chord position	3.8
Faired lamps on lower surface at 10 percent chord position	1.6
Unfaired lamps on lower surface at 10 percent chord position	4.2

Figure 1.-
 Dimensions
 of Army Air
 Corps type
 A-6 landing
 lamp.

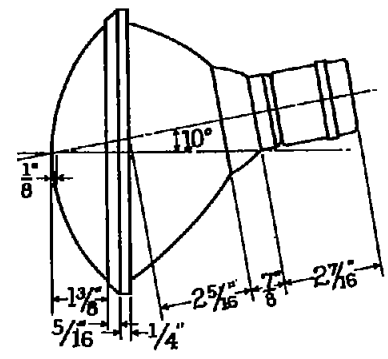
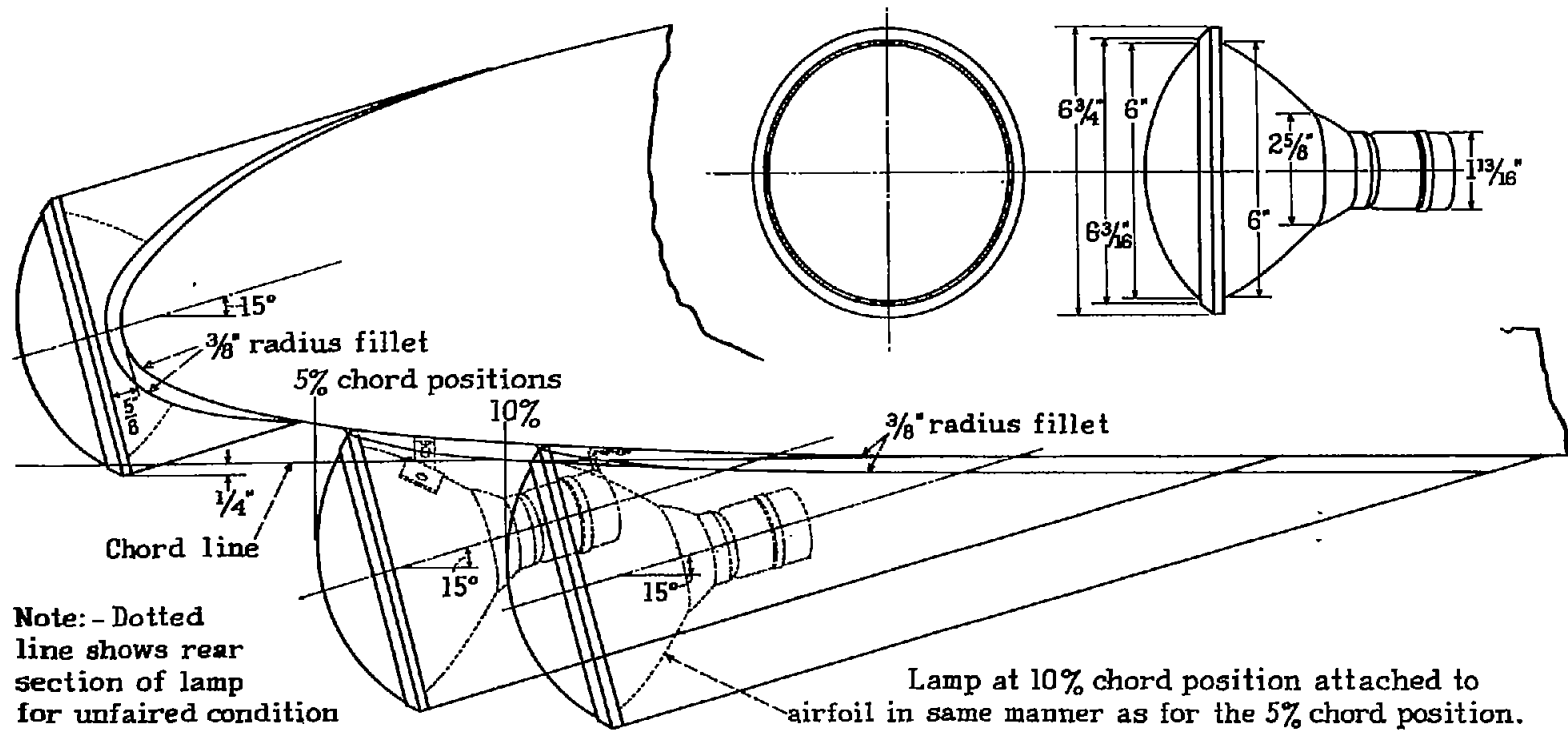

Figure 2.-
 Lamp
 installations
 on airfoil.



Note: - Dotted
 line shows rear
 section of lamp
 for unfaired condition

Lamp at 10% chord position attached to
 airfoil in same manner as for the 5% chord position.



Unfaired lamp in leading edge.



Faired lamp in leading edge.



Unfaired lamp on lower surface at 10 percent chord position.



Faired lamp on lower surface at 10 percent chord position.

Figure 3.- Photographs of lamp installations in the leading edge and on the lower surface of the airfoil at the 10 percent chord position.

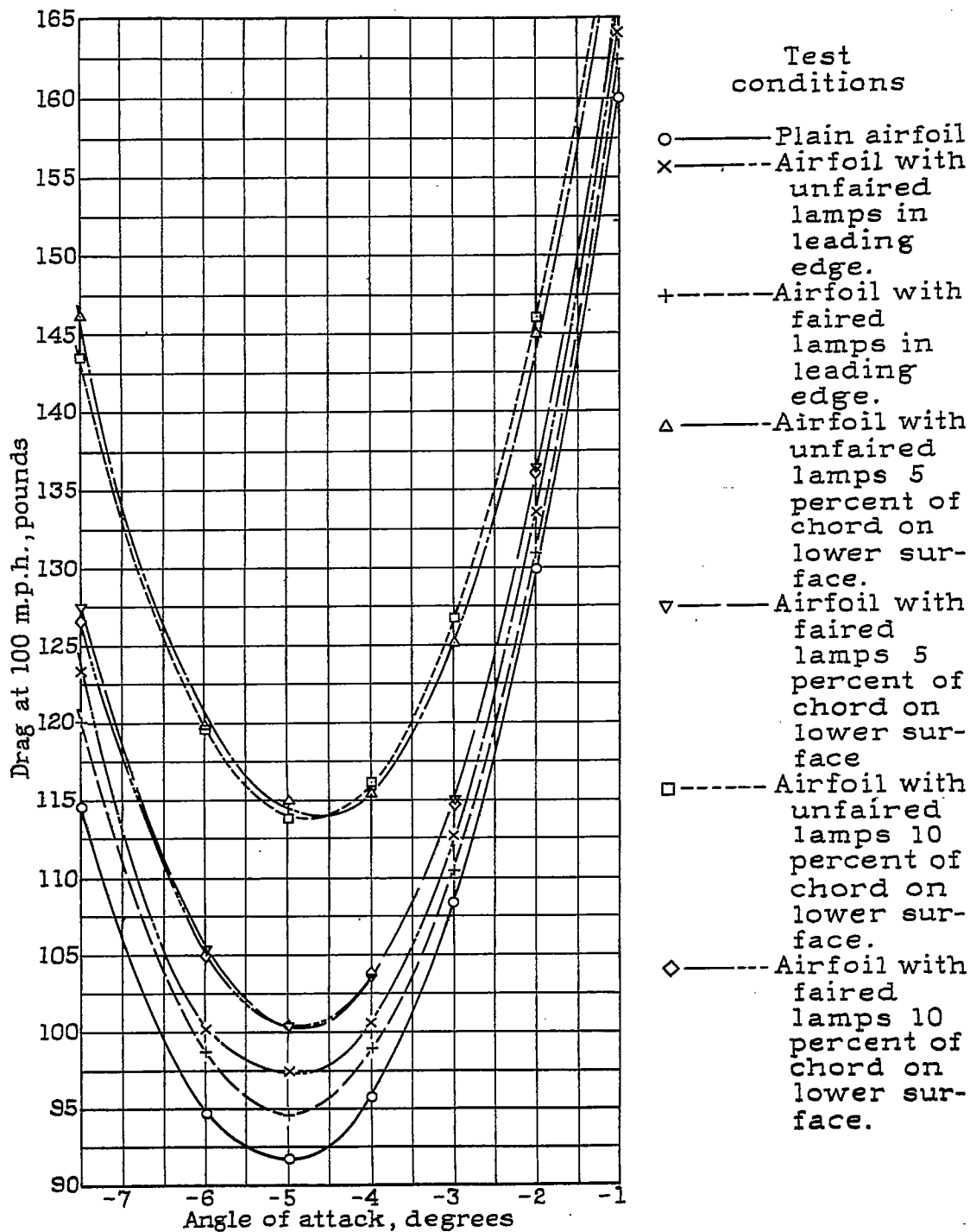

Figure 4.- Airfoil drag at 100 miles per hour for the lamp arrangements tested. Results not corrected for tunnel jet boundary effect.