

for Aeronautics

MAILED

NOV 21 1939

To Library, *L. M. a. h.*

THIS DOCUMENT PROVIDED BY THE ABBOTT AEROSPACE
TECHNICAL LIBRARY
ABBOTTAEROSPACE.COM

TECHNICAL NOTES

NATIONAL ADVISORY COMMITTEE FOR AERONAUTICS

No. 737

PHOTOELASTIC ANALYSIS OF THREE-DIMENSIONAL

STRESS SYSTEMS USING SCATTERED LIGHT

By R. Weller and J. K. Bussey
Langley Memorial Aeronautical Laboratory

Washington
November 1939

3 1176 01425 7266

NATIONAL ADVISORY COMMITTEE FOR AERONAUTICS

TECHNICAL NOTE NO. 737

PHOTOELASTIC ANALYSIS OF THREE-DIMENSIONAL
STRESS SYSTEMS USING SCATTERED LIGHT

By R. Weller and J. K. Bussey

SUMMARY

A method has been developed for making photoelastic analyses of three-dimensional stress systems by utilizing the polarization phenomena associated with the scattering of light. By this method, the maximum shear and the directions of the three principal stresses at any point within a model can be determined, and the two principal stresses at a free-bounding surface can be separately evaluated. Polarized light is projected into the model through a slit so that it illuminates a plane section. The light is continuously analyzed along its path by scattering and the state of stress in the illuminated section is obtained. By means of a series of such sections, the entire stress field may be explored. The method was used to analyze the stress system of a simple beam in bending. The results were found to be in good agreement with those expected from elementary theory.

INTRODUCTION

A new method for the photoelastic analysis of three-dimensional (spatial) stress systems was reported in detail at the Eastern Photoelastic Conference at Cornell University in May 1939. A brief description of the method is outlined in reference 1. Following the announcement of the method, the N.A.C.A. constructed a simple polariscope suitable for preliminary work and began the study of the application of the method to aircraft structures, power plants, and other related problems.

Several investigators have attempted to develop a truly three-dimensional method of photoelastic analysis. With the exception of the fixation method reported in reference 2, these attempts have lacked general usefulness. In the present paper, the basic principles underlying the

proposed three-dimensional method are discussed and a concrete example is worked out to show its application.

THE PHOTOELASTIC METHOD

The photoelastic method (references 3, 4, and 5) is based on the fact that many materials, notably certain plastics, become doubly refractive (birefringent) when subjected to stress. The amount of this birefringence may be studied with a polariscope and the characteristics of the stress system obtained. A model of a machine part or of a structural part may therefore be made from such a material and subjected to an appropriate loading system; and the state of stress within it can then be determined. If the materials from which the model and its prototype are made possess similar (proportional) elastic properties, the stress systems will coincide in direction and be proportional in magnitude provided that the deflections are such that the geometry remains substantially undisturbed.

It has been common in the past to study stresses in this manner, but such study has been limited in practice to plane stress systems. Models were cut from plates and loaded in a single plane. Many problems have been solved in this manner and valuable data obtained.

Models have been made from glass, celluloid, gelatin, Bakelite, Marblette, and rubber, but the material known as Bakelite BT-61-893 has been generally accepted as the most suitable for a wide variety of tests. It remains linearly elastic over a wide stress range (0 to 6,000 lb. per sq.in.), its elastic modulus is not too low (600,000 lb. per sq.in.), and its stress-optical coefficient is high (85 lb. per sq. in. per fringe for green light). A discussion of the properties of photoelastic materials is given in reference 6.

SPATIAL PHOTOELASTIC ANALYSIS

The theory of photoelastic analysis as applied to three-dimensional stress systems will now be considered in some detail. The difficulty in three-dimensional photoelastic analysis by conventional methods has been that, when a beam of light passes through a transparent model in which a spatial stress system exists, the relative retarda-

tion observed between the components of the emergent beam is an integrated effect along the total path traversed. No means have hitherto been available for conveniently discovering the way in which the relative retardation takes place along the path.

When light is scattered within a material medium at right angles to the incident beam, the scattered light (reference 7) is plane polarized. This scattering property may be used either as the polarizer or the analyzer in a polariscope. In Bakelite, this phenomenon is perhaps due to the micelles discussed by Hetényi (reference 2).

In the investigation of the variation in the effect of the birefringence on a light beam as it passes through a model, a source of polarized light within the model capable of motion from point to point might be desirable. In order to produce such a source, an unpolarized beam may be projected into the model and the scattered light may be viewed from a direction 90° to the beam. This arrangement may most conveniently be set up by collimating the beam with a lens and subsequently passing it through a slit, say one-eighth of an inch wide and as long as desired. When this beam is passed through the model, it illuminates a plane section. Viewed along any path normal to the illuminated section, the light appears plane polarized. If the model is now loaded and an external analyzer employed, the birefringence of the material between the illuminated section and the analyzer will produce interference effects that vary when either the model or the incident beam is moved about. If a section is illuminated at the surface near the observer and moved away from him, the space rate of formation of fringes, dN/ds , is a measure of the birefringence in successive planes normal to the observation direction. Here N is the number of cycles of interference observed along the path and s is the path variable.

Owing to the complications involved in accurately measuring the movement of the light beam, another method of surveying the model is recommended. Let a plane polarized beam be projected into the model through a slit as previously described. The scattering process in the model then acts as the analyzer rather than as the polarizer and no external analyzer is required. The value of dN/ds is now a measure of the birefringence in successive planes normal to the incident light beam.

The relations between the birefringence and the stresses

at any point in a loaded model may be considered as follows. When a material (such as Bakelite) becomes optically anisotropic, its optical properties at a given point may be conveniently described in terms of three principal indices of refraction, n_1 , n_2 , and n_3 . These indices always lie at right angles to each other in space. If the optical anisotropy is due to stress, the three principal indices will lie in the direction of the three principal stresses (S_1 , S_2 , and S_3). Furthermore, the departures of the three indices n_1 , n_2 , and n_3 from the unstressed value n_0 are proportional to S_1 , S_2 , and S_3 ; that is,

$$K(n_0 - n_1) = S_1$$

$$K(n_0 - n_2) = S_2$$

$$K(n_0 - n_3) = S_3$$

where K is a constant characteristic of the material. In another form

$$K(n_2 - n_1) = S_1 - S_2$$

$$K(n_3 - n_2) = S_2 - S_3$$

$$K(n_1 - n_3) = S_3 - S_1$$

If $S_1 < S_2 < S_3$, the maximum shear is given by

$$\tau_{\max} = \frac{K}{2} (n_1 - n_3)$$

The maximum shear at a point may then be found by measuring $n_1 - n_3$ at the point, provided that K is known.

If a beam of polarized light passes through the point in question along the direction of S_2 and is polarized at 45° to S_1 and S_3 , the relative velocity of its components will depend on the ratio of n_1 to n_3 . Relative retardation will take place between the components at a rate given by

$$dR = (n_1 - n_3) ds$$

or, expressing the relative retardation in wave lengths,

$$\frac{dN}{ds} = \frac{1}{\lambda} (n_1 - n_3) = \frac{1}{K\lambda} (S_3 - S_1) = \frac{1}{C} (S_3 - S_1)$$

where λ is the wave length in air of the light used, N is the amount of the relative retardation in wave lengths (cycles of interference), and C is another constant called the stress-optical coefficient of the material. Inasmuch as it is proposed to analyze the light continuously along its path by scattering, a fringe will appear each time the relative retardation equals a whole number of wave lengths; that is, when

$$R = N\lambda \quad (N = 1, 2, 3, \dots, m)$$

If the direction of S_2 is unknown, the beam of light may be passed through the point in various directions until dN/ds is a maximum; that is, until the fringes appear most closely spaced. The light beam is then traveling along the direction of S_2 . If it is assumed that the stresses remain sensibly constant over a small increment of light path, the formula may be written as

$$S_3 - S_1 = C \frac{\Delta N}{\Delta s}$$

If the increment is such that $\Delta N = 1$, then Δs is the fringe spacing and hence measurement of Δs determines $(S_3 - S_1)$. If Δs is referred to as d , then

$$S_3 - S_1 = \frac{C}{d}$$

Certain phases of the fringe formation process will now be considered. The scattered light is considered to be due to the vibration of submicroscopic particles in the scattering medium. These particles vibrate in the direction of the electric vector of the incident beam of light. In birefringent material, such a particle vibrates under the influence of each of the two components into which the light divides. Light being a transverse wave motion, only the component of vibration normal to the direction of observation yields visible light. Hence, the vibrating particle should be viewed from a direction such that both light components take part in forcing the vibration. Interference between components will then be visible. If the light beam travels along S_2 and the observer looks along S_1 or S_3 , no interference effects will be visible but, if the observer looks along a direction 45° to S_1 and S_3 , fringes with maximum visibility will be seen. The po-

sitions of minimum fringe intensity give the directions of S_1 and S_3 .

As a simple example of this procedure, consider the case of a tension member of rectangular cross section. Let a beam of light be collimated, plane polarized, and projected into such a model through a slit. Let the slit lie parallel to the stress direction so that the illuminated section is a longitudinal one through the piece. Let the light be polarized in a direction at 45° to the direction of the stress. If the model is observed from a direction either parallel to or normal to the direction of polarization and at 90° to the incident light direction, fringes will appear which are equally spaced. Hence dn/ds is a constant, and therefore the birefringence is constant along the light paths. The result then indicates that the stress in the model is constant over the cross section. Such a fringe pattern is shown in figure 1. A vector diagram of the light components is shown in figure 2. This diagram refers to the point at which light enters the model and before relative retardation has taken place between its components. Observation along A corresponds to the case in the plane-stress polariscope in which the polarizing units are set for a dark field and, along B, to the case of a light field.

The principal stresses at a free boundary may be individually measured since the stress perpendicular to such a boundary vanishes and the other two stresses lie in the tangent plane. If the direction of the light is made parallel to this tangent plane, the model may be rotated about a point in the tangent plane until the maximum and the minimum fringe spacings are obtained. These spacings will give the separate principal stress values.

APPARATUS

The apparatus employed for this study included a polariscope head containing a light source, condensing lenses, a filter, a polarizing plate, and a slit. Above the head was placed a glass tank filled with a suitable liquid in which the models were immersed. A camera was provided for photographic recording. The arrangement of these elements is shown in figures 3 to 5.

The light source for these studies must be intense

and a type H-6 Westinghouse 1,000-watt mercury arc lamp of the water-jacketed variety was obtained. This lamp has been very satisfactory as regards intensity. Its spectrum, however, contains many more lines than the ordinary mercury arc and apparently has a fairly intense continuous background, so that difficulty was experienced at first in obtaining a monochromatic beam. Such a beam is highly desirable to prevent overlapping of various colors at high orders of interference. The combination of a Wratten No. 77 filter with a Wratten B filter seemed best for photographic recording and the Wratten No. 77 alone for visual observation. The problem is further complicated by the variation in monochromatic scattering power for Bakelite, which is apparently strongest in the blue region, as would be expected. The lamp requires a separate transformer operating on 110 volts alternating current and a water supply of about 1 gallon per minute. Provision for automatic shut-off of the power supply in the event of water-supply failure was not provided, although the automatic feature is very desirable.

Two condensing lenses 6.5 inches in diameter served to collimate the light beam, the lamp being placed at the focal point of the combination. The approximate speed of the condensing-lens system was $f:0.83$.

The polarizer employed was a sheet of type I Polaroid. No quarter-wave plate was used during the tests to be described, but one may occasionally be necessary to project circularly or elliptically polarized light into the model.

The slit was approximately one-tenth inch wide and equal in length to the diameter of the collimated beam. Naturally, the intensity of the fringes and the speed of photographic recording vary directly with the slit width. The width used resulted in fringes easily visible in daylight. The exposures were of the order of 1 minute with the filter combination mentioned and a high-speed film. On the other hand, the slit width effectively determines the gage length over which the measurements are made; hence, it should be as narrow as possible consistent with satisfactory visibility and photographic exposure. Good visibility was obtained with the slit width greatly reduced, probably to about 0.01 inch.

In order to avoid refraction at model surfaces, the model must be immersed in a clear liquid having the same refractive index ($n = 1.57$) as Bakelite. A mixture of the following proportions (by volume)

Halowax oil No. 1000 ($n = 1.63$) 66 percent

Clear mineral oil ($n = 1.43$) 34 percent

was found to give the correct refractive index. This liquid was contained in a glass-wall tank 8 inches by 8 inches by 6 inches deep, made of plate glass united with Sauer-eisen cement.

EXPERIMENTAL PROCEDURE

A beam in uniform bending was selected as an example of the method. The stresses under a given loading were photoelastically measured and were subsequently checked by calculation according to the elementary theory. Two beams were cut from a block of Bakelite BT-61-893. No annealing was attempted. The models were 0.75 inch by 0.75 inch in cross section and were 6 inches in length. They were loaded in a small fixture constructed for the purpose. Figures 6 and 7 show a beam in place. Loads were found by measuring the deflection of the spring contained in the fixture.

One beam was cut from the Bakelite block along an edge exposed during the "curing" process. This beam showed the prominent initial stress pattern seen in figure 8(a). In figures 8(b) and 8(c) are shown the fringe patterns in this beam due to one-half load and full load in bending. It will be noted that the distortion of the pattern from symmetry about the neutral axis decreases with increasing load, that is, the relative influence of the initial stresses decreases.

Figure 9 shows the bending pattern of the second beam, which was cut from the parent material in such a way as to be well removed from previously exposed surfaces. This pattern shows satisfactory symmetry and was taken as the basis for comparison with theory. Table I shows the values obtained. The procedure in obtaining the data was as follows: The negative of figure 9 was placed on the stage of a micrometer comparator and traverses were made along a vertical line at the center of the beam. Positions of the dark fringes are recorded in the first column of table I. Inasmuch as the image on the negative was reduced in size as compared with the beam itself, the readings were multiplied by a factor (1.93) after subtraction from the initial reading as shown in the second column. The second column then gives the displacement of the fringes from the edge of

the beam through which the light entered. The stress value obtained from the spacing between a given pair of fringes was assumed to correspond to a point midway between them. The third column gives the location of these points. The actual spacing of the fringes is shown in the fourth column. In the last column are recorded the stresses obtained by dividing the fringe value of 85 pounds per square inch per fringe by the spacing.

The neutral axis of the beam (center line of the model) represents a barrier across which fringe-spacing measurements cannot be made. Such a measurement would give the spacing of a fringe with respect to itself and such a measurement has no meaning. The spacing across a region in which a reversal from tension to compression, or vice versa, takes place bears no relation to the stress but depends rather on the relative phase of the light components as they cross the neutral section. Only when this phase difference is accidentally zero, will the measurement be significant in terms of stress.

The values from table I are plotted in figure 10. Inasmuch as this type of stress distribution is a straight line to a good approximation, such a line was drawn through the points. Calculation using the applied load of 350 pounds and moment arms of 1.37 inches gives

$$\sigma = \frac{M}{Z} = \frac{175 \times 1.37 \times 6 \times 64}{27} = 3,400 \text{ pounds per square inch}$$

where σ is the maximum stress in the beam, M is the bending moment on the beam, and Z is the section modulus of the beam. This value compares with the value of 3,600 pounds per square inch given by the intersection of the plotted value line with the model edges. The discrepancy here is 5.5 percent of the computed value. The average deviation of the significant points from the curve is 4 percent.

As some of the equipment used was incapable of precise measurement, the result is considered good agreement. Sources of error may have been:

- (1) Error in model dimensions.
- (2) Error in spring calibration.
- (3) Error in spring-deflection measurement.

- (4) Error in measuring roller positions on beam.
- (5) Friction in loading fixture.
- (6) Error due to deflection of beam.
- (7) Errors due to photographic distortion.
- (8) Errors in centering fringe line in micrometer comparator.
- (9) Error due to proximity of load points.
- (10) Error due to strains in tank bottom.
- (11) Error due to strains in Polaroid disk.
- (12) Error due to lack of perfectly monochromatic light.
- (13) Initial optical anisotropy in the model.
- (14) Error in fringe value for Bakelite due to temperature.

It is probable that items (3), (4), (5), (8), (9), and (13) contributed the larger part of the final error. An exception is the uncertainty in the reading of the position of the first fringe with respect to the model edge. This value was rejected as being accounted for by items (10), (11), and (13), but chiefly by (10). It is advisable to approach a bounding surface from within and to reduce the effect of these items by plotting a curve such as has been done here. Items (10) and (11) can affect only the position of the first fringe.

In general, it may be said that the errors listed in items (1) through (9) are not characteristic of this method of stress analysis and may be controlled by well-known methods. Errors due to (10), (11), and (12) can be eliminated without difficulty by the use of well-designed equipment. Item (13) is controllable by suitable choice of model material; by careful machining; and by testing the model soon after cutting; or, when such testing is inconvenient, by measuring the initial conditions without load and subtracting the result from later readings. The variation due to item (14) is small because of the manufacturer's care in processing (reference 6).

An additional possible source of error is due to the assumption that the stress computed by the spacing of two adjacent fringes exists at a point midway between them. This assumption is more nearly true as the spacing of fringes becomes more uniform with high loads. In the present example, the departure of the representative point from the midway position could have been computed, but computation is generally impossible. Here, as in plane photoelastic analysis, a high fringe order is conducive to precise results.

As an example of the usefulness of the method in a slightly more complex problem, the variation in the stress pattern due to a vertical hole through the center of a beam is presented. A hole of 5/16-inch diameter was drilled through the center of the beam previously analyzed. Figures 11 and 12 show the stress patterns in the central plane and in the face of the beam, respectively.

The disturbance in the fringe pattern at the load points was insignificant for both beams tested. This result is in contrast to the prominent effects obtained in the usual plane-stress pattern. In the three-dimensional method, the components of stress that lie in horizontal planes are effective and no vertical stress components influence the fringe positions. If the model had been illuminated by a horizontal beam, the resulting fringes would have indicated the effect of the concentrations very prominently. The operator must not expect to see the types of fringe patterns that have come to be associated with photoelastic methods in the past because the present procedure involves a new type of stress-optical behavior.

CONCLUDING REMARKS

The foregoing results indicate that the method developed for three-dimensional photoelastic stress analysis is sound, that the apparatus described is suitable for a wide variety of stress investigations, and that the experimental techniques employed yielded satisfactory results. This method appears to be a substantial improvement over previous attempts to solve spatial stress problems by the use of photoelastic models and, in a large number of cases, appears to be the only method thus far developed that will provide a solution in a convenient manner.

In the solution of the case of the beam in simple bending, as analyzed by the method outlined in the paper, the agreement with accepted beam theory was within 5.5 percent. No basic assumptions are made in developing the theory other than those already well established in plane photoelastic procedure.

Persons should familiarize themselves with the elementary phenomena associated with the scattering of light before attempting experiments by this method.

It may at times be desirable to submit to some of the disadvantages of the fixation method and, having "frozen" a stress system into a model, to examine it by the methods described in this paper. The tension model used in this investigation was so treated.

The principal stresses at a free boundary may be individually measured since the stress perpendicular to such a boundary vanishes and the other two stresses lie in the tangent plane. If the direction of the light is made parallel to this tangent plane, the model may be rotated about a point in the tangent plane until the maximum and the minimum fringe spacings are obtained. These spacings will give the separate principal stress values.

Many problems suggest themselves as suitable subjects for investigation. Certainly stress concentrations in three-dimensional systems should be thoroughly explored, particularly in connection with torsional stresses. It also seems possible that some of the problems which have been treated as two-dimensional ones in the past may not in fact be two-dimensional and that more accurate results could be obtained by the suggested method.

Langley Memorial Aeronautical Laboratory,
National Advisory Committee for Aeronautics,
Langley Field, Va., October 26, 1939.

REFERENCES

1. Weller, R.: A New Method for Photoelasticity in Three Dimensions. Jour. Appl. Phys., vol. 10, no. 4, April 1939, p. 266.
2. Hetényi, M.: The Fundamentals of Three-Dimensional Photoelasticity. Jour. Appl. Mech., vol. 5, no. 4, Dec. 1938, pp. A-149 - A-155.
3. Coker, E. G., and Filon, L. N. G.: A Treatise on Photoelasticity. Cambridge Univ. Press, 1931.
4. Riggs, Norman C., and Frocht, Max M.: Strength of Materials. The Ronald Press Co., 1938, ch. 13.
5. Mindlin, Raymond A.: A Review of the Photoelastic Method of Stress Analysis. Jour. Appl. Phys., vol. 10, no. 4, April 1939, pp. 222-241 and vol. 10, no. 5, May 1939, pp. 273-294.
6. Lee, G. H., and Armstrong, C. W.: Effect of Temperature on Physical and Optical Properties of Photoelastic Materials. Jour. Appl. Mech., vol. 5, no. 1, March 1938, pp. A-11 - A-12.
7. Wood, Robert W.: Physical Optics. The Macmillan Co., 1919, ch. XXII.

TABLE I

Data on Cross Section of Bakelite
 BT-61-893 Beam, Correctly Cut

Position of dark fringes on negative (in.)	Position of fringes in model (in.)	Stress location (in.)	Fringe spacing (in.)	Stress values (lb./sq. in.)
0.524	0			
.534	.019	0.010	0.019	4,500
.548	.046	.032	.027	3,150
.562	.073	.060	.027	3,150
.578	.104	.089	.031	2,750
.597	.141	.122	.037	2,300
.619	.183	.162	.042	2,000
.644	.232	.206	.049	1,750
.691	.322	.277	.090	950
Centerline of model				
.758	.452	.488	.073	1,150
.796	.525	.550	.050	1,700
.822	.575	.595	.041	2,050
.843	.616	.632	.032	2,650
.860	.648	.662	.028	3,050
.874	.676	.690	.028	3,050
.890	.704	.718	.029	2,950
.904	.733			
edge .912	.749			

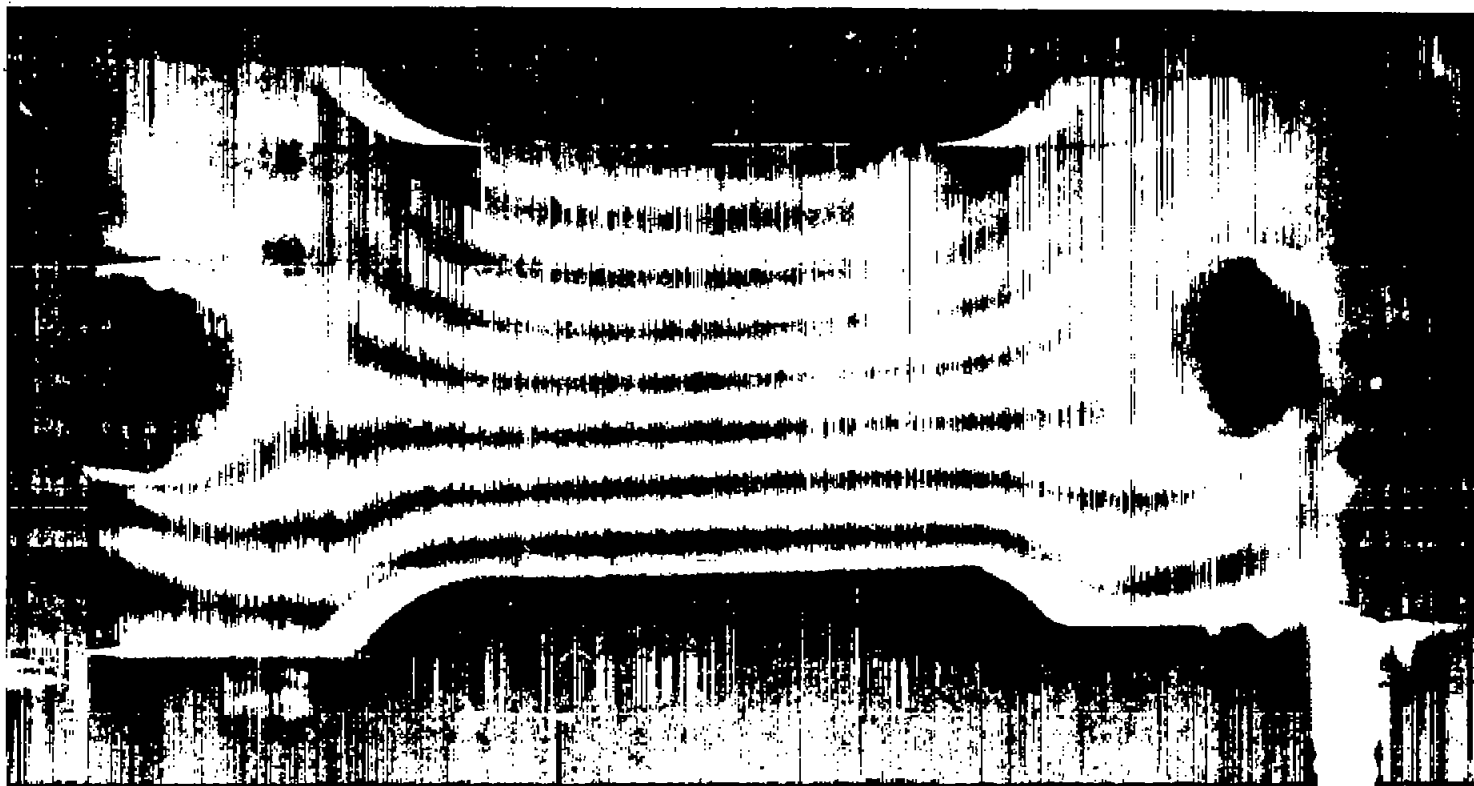

Figure 1.- Fringe pattern in tension specimen.

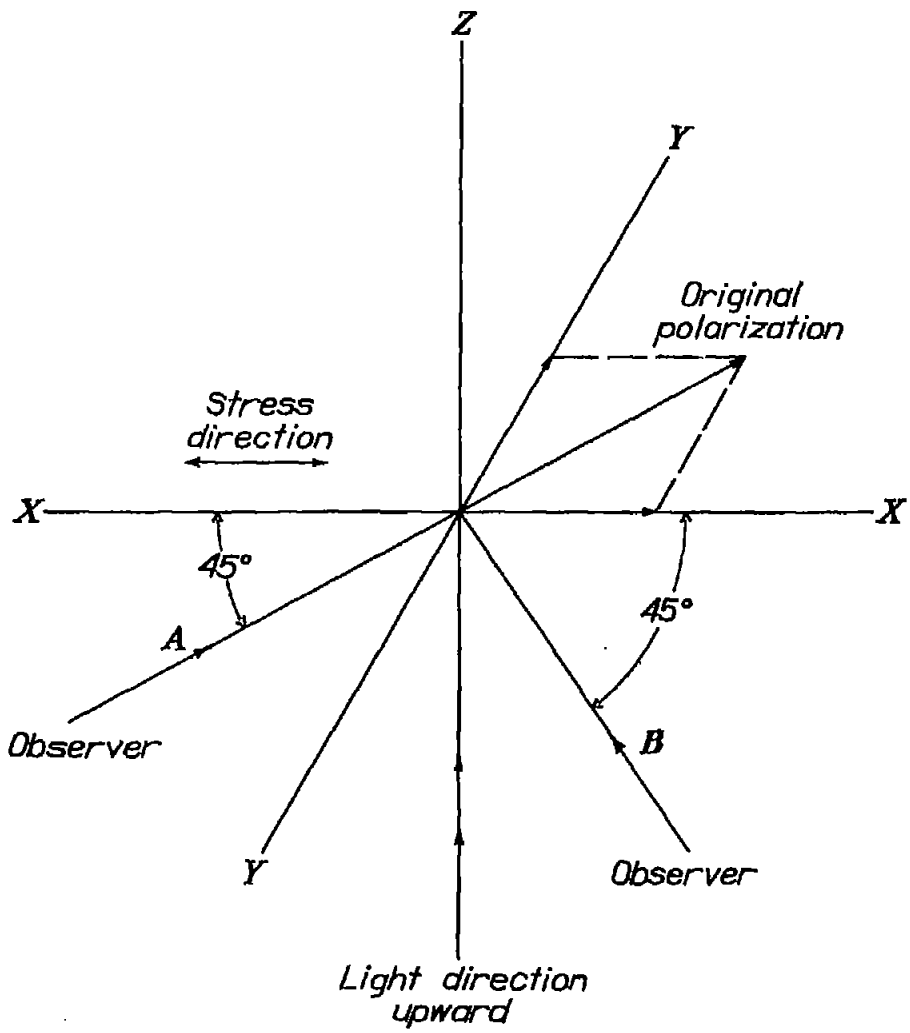

Figure 3.- Vector diagram for tension.

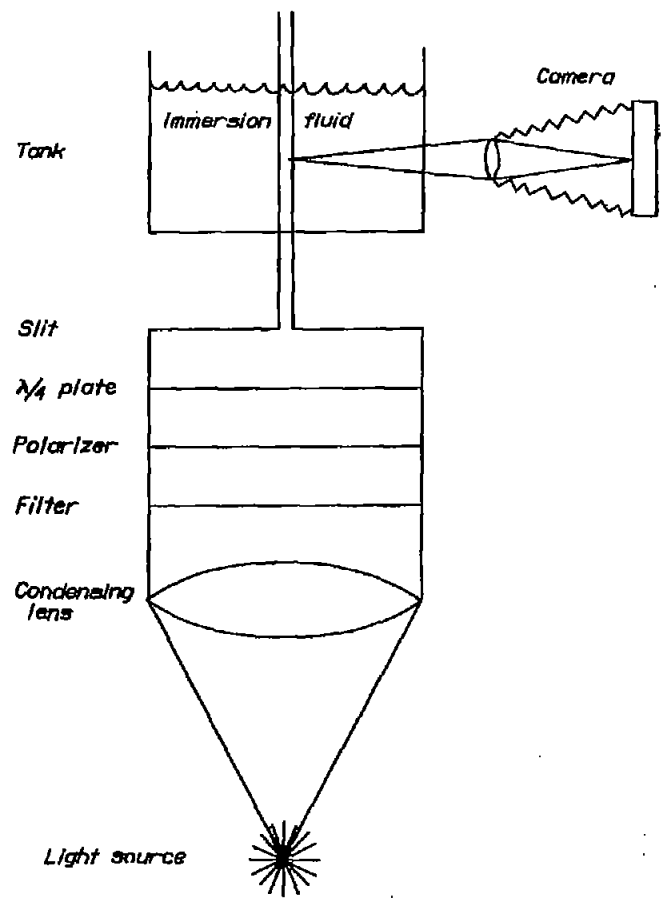

Figure 5.- Schematic diagram of polariscope.

N.A.C.A. Technical Note No. 737

Figs. 3, 5

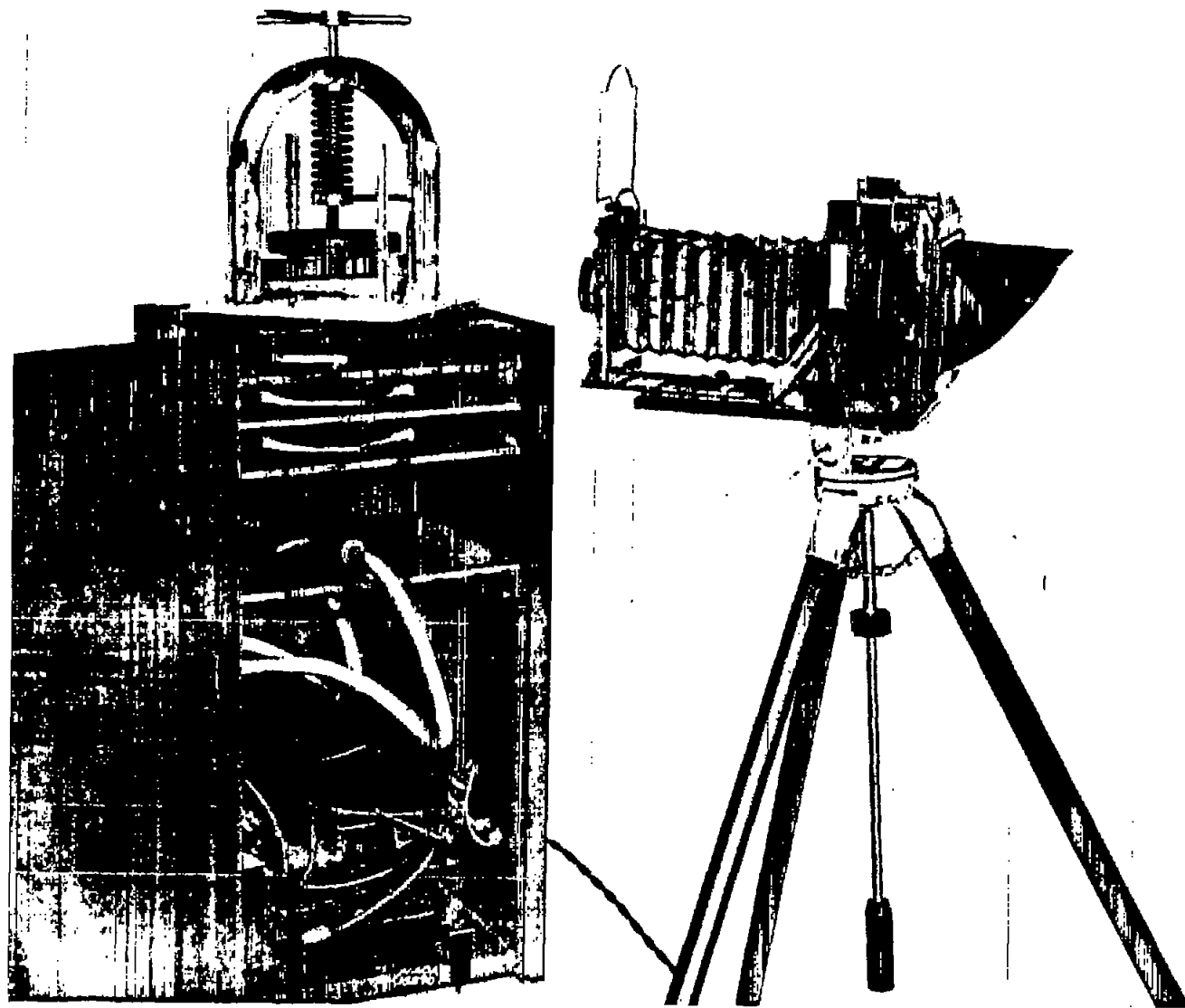

Figure 3.- General view of apparatus showing location of polariscope, tank, model, and camera.



Figure 4.- Internal layout of polariscope.

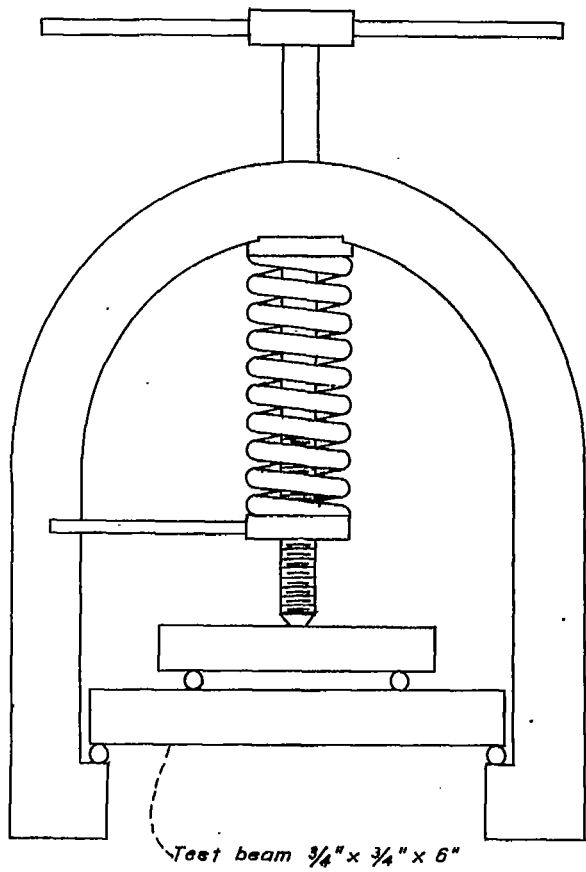

Figure 6.- Loading fixture.

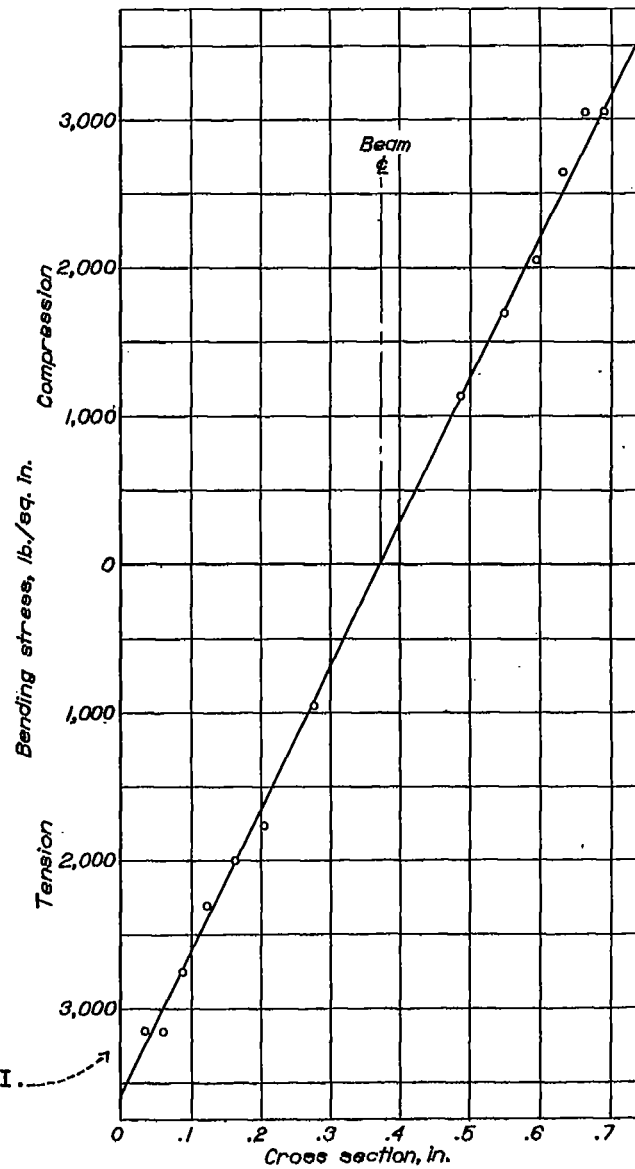

Figure 10.- Beam stress plotted from values in table I.

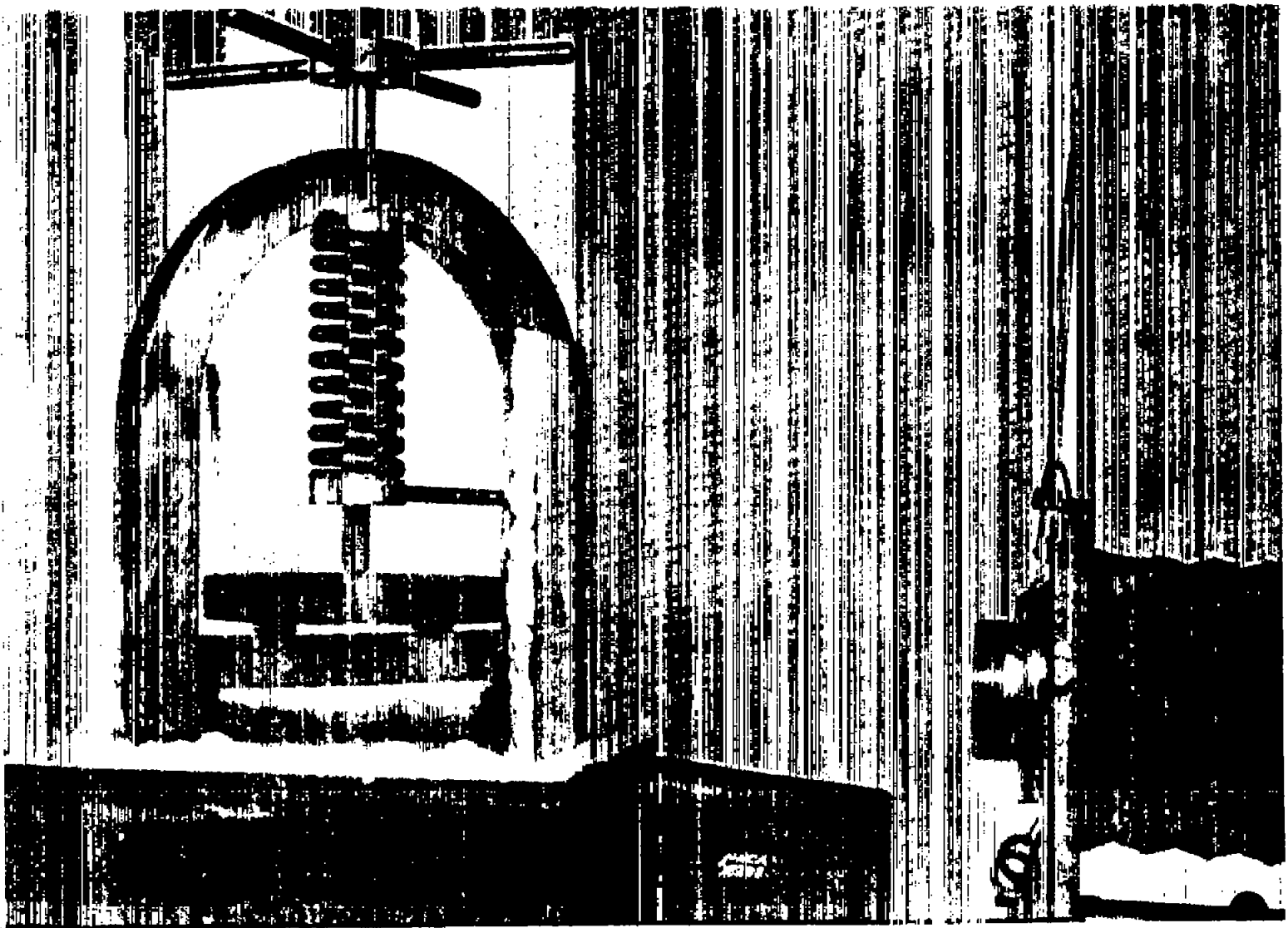
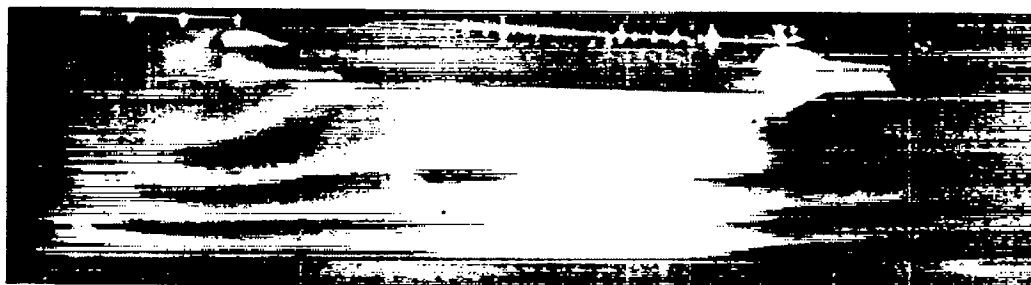
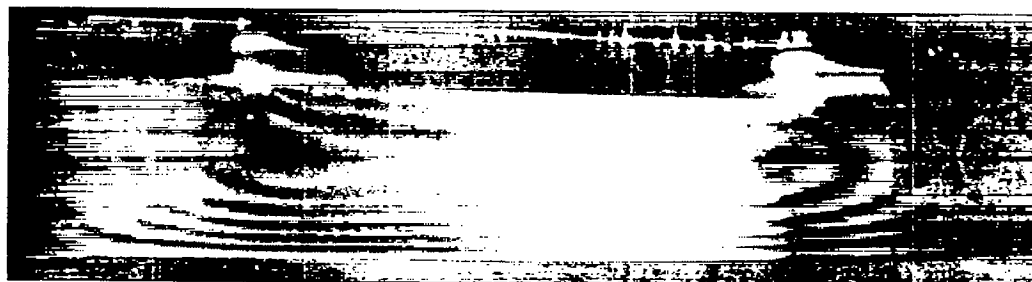

Figure 7.- Loading fixture with model in place.



(a) Initial stress pattern(no load).



(b) Half bending load.

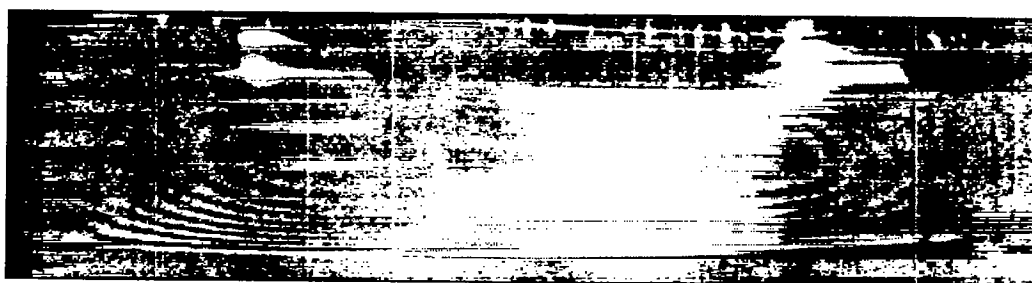

(c) Full bending load.

Figure 8.- Stress patterns in a Bakelite beam showing initial stress resulting from an edge that has been exposed during curing.

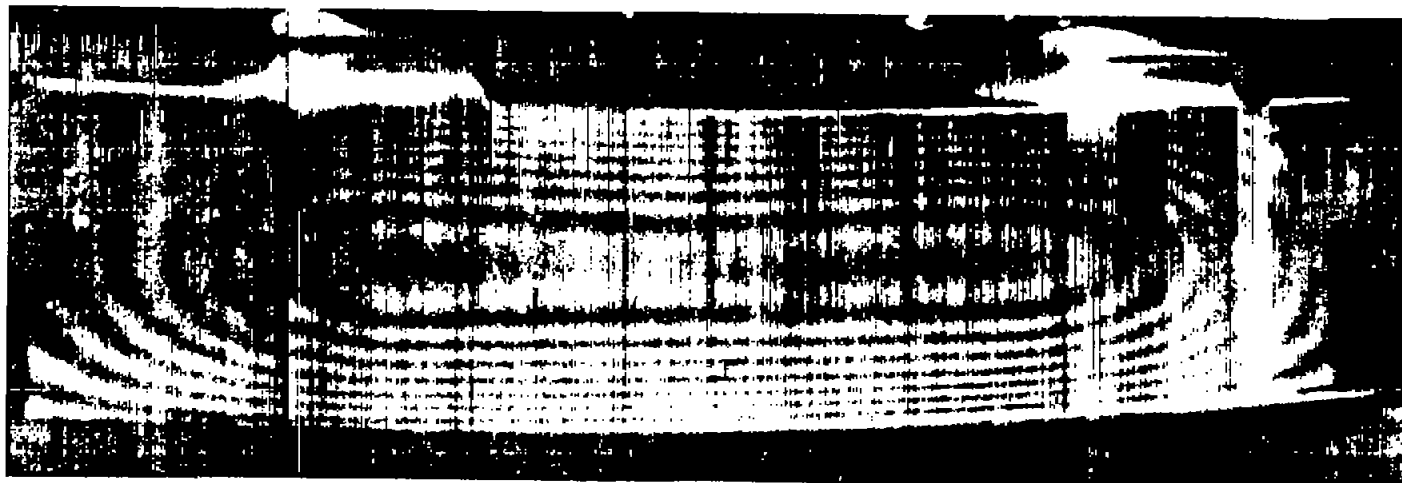

Figure 9.- Bending stress pattern in correctly cut beam.

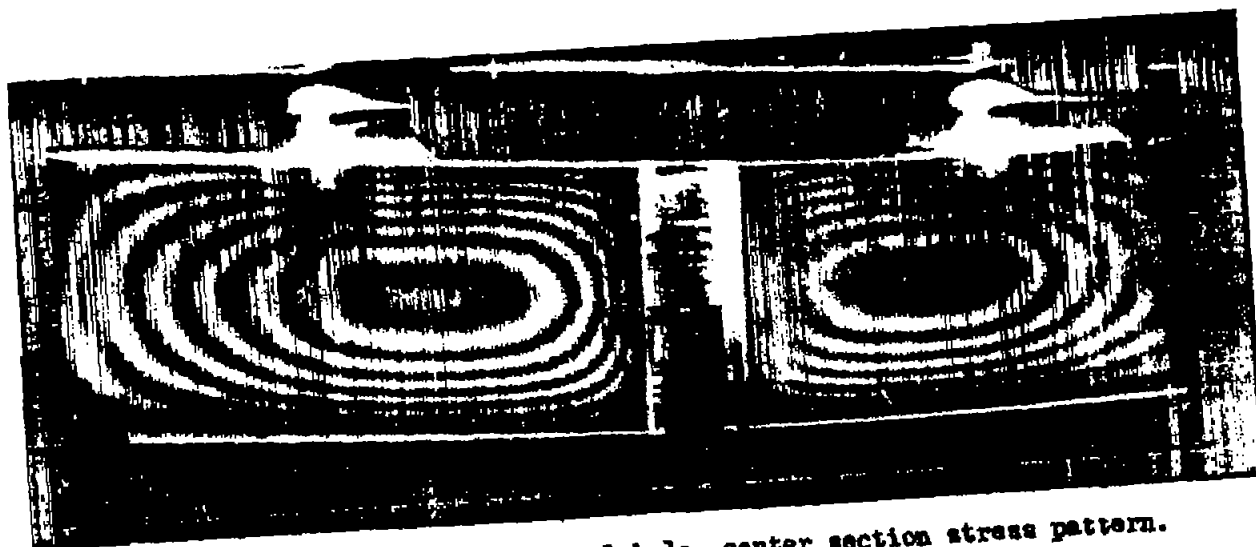

Figure 11.- Beam with vertical hole, center section stress pattern.

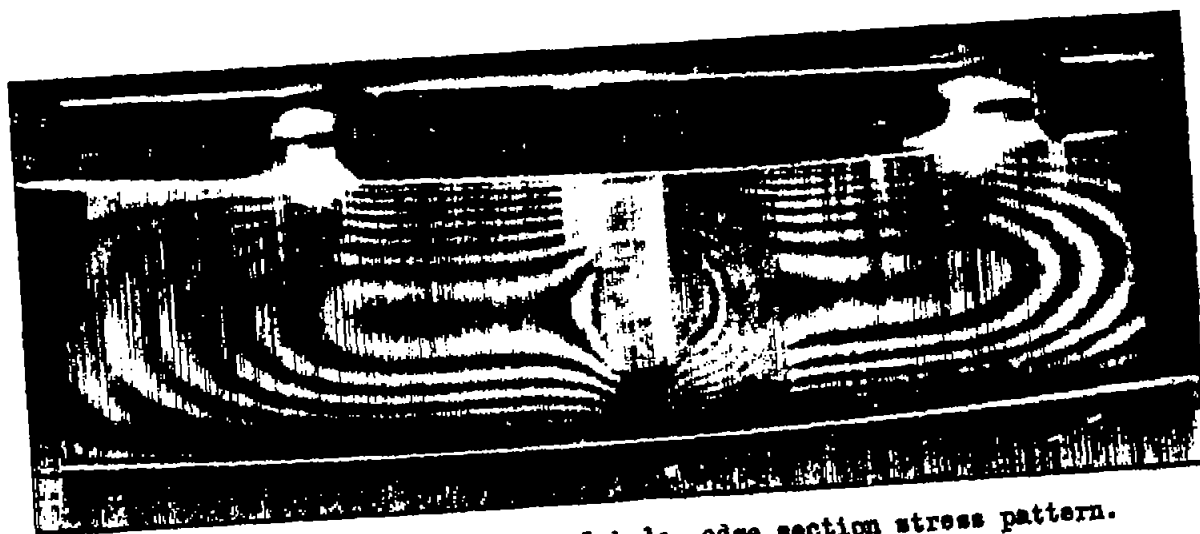

Figure 12.- Beam with vertical hole, edge section stress pattern.

N.A.C.A. Technical Note No. 737

Figs. 11, 12