

National Advisory Committee
for Aeronautics
MAILED

DEC 13 1939

To Library, *L.M.A.C.*

THIS DOCUMENT PROVIDED BY THE ABBOTT AEROSPACE
TECHNICAL LIBRARY
ABBOTTAEROSPACE.COM

DEC 18 1939

TECHNICAL NOTES

NATIONAL ADVISORY COMMITTEE FOR AERONAUTICS

No. 740

STRESS CONCENTRATION AROUND AN OPEN CIRCULAR HOLE
IN A PLATE SUBJECTED TO BENDING NORMAL
TO THE PLANE OF THE PLATE

By C. Dumont
Aluminum Company of America

To be returned to
the files of the Langley
Memorial Aeronautical
Laboratory.

Washington
December 1939



3 1176 01425 7282

NATIONAL ADVISORY COMMITTEE FOR AERONAUTICS

TECHNICAL NOTE NO. 740

STRESS CONCENTRATION AROUND AN OPEN CIRCULAR HOLE
IN A PLATE SUBJECTED TO BENDING NORMAL
TO THE PLANE OF THE PLATE

By C. Dumont

SUMMARY

An aluminum-alloy plate containing an open circular hole of diameter large compared with the thickness of the plate was subjected to bending forces normal to the plane of the plate. Deflection and strain measurements were taken for two different loads.

Stress concentrations occurred at the edge of the hole and the maximum stresses were tangential to the hole at the ends of the transverse diameter. The maximum stress at the edge of the hole was 1.59 times the computed stress on the net section and 1.85 times the computed stress in a solid plate of the same dimensions subjected to the same bending forces. The maximum deflections were about 20 percent greater than the corresponding deflection for a solid plate of the same size subjected to the same bending forces.

The smallest edge distance was equal to 2-1/2 times the diameter of the hole and the stress concentration on this side of the hole was the same as on the side where the edge distance was about 4-1/2 diameters. A theoretical analysis of the problem shows that, for an aluminum plate of infinite width, the stress concentration at the edge of the hole would be 1.87 times the stress in a solid plate, which is substantially the same relation obtained for the plate tested.

INTRODUCTION

It is a well-established fact that holes, fillets, and other discontinuities in force-carrying members give rise to concentrations of the stresses in the vicinity of the

discontinuities. Under conditions of repeated loading, these stress-concentration effects are of great importance because they materially reduce the fatigue strength of the members. In recent years, this problem has received considerable attention and the stress-concentration factors for open holes, notches, and fillets have been determined by both photoelastic (references 1, 2, and 3) and analytical (references 4 and 5) methods. To a large extent, however, these investigations have been confined to specimens subjected to forces producing two-dimensional stress systems. Tuzi (reference 3) and Howland and Stevenson (reference 5) have studied the distribution of stresses in a plate containing a centrally located open circular hole and subjected to bending forces parallel to the plane of the plate. The problem of a plate containing an open circular hole and subjected to bending forces normal to the plane of the plate has been analytically studied by Goodier (reference 6). No results of any experimental determination of the stress concentration around an open hole in a plate subjected to bending forces normal to the plane of the plate have been found. The lack of experimental information regarding this problem is readily explained when it is realized that the stresses are three-dimensional and hence have not been determined by photoelastic methods.

In view of this lack of data, it was decided to subject a plate containing an open circular hole to bending forces normal to the plane of the plate and to determine by means of strain and deflection measurements definite experimental information regarding the distribution and the magnitude of the stresses and the deflections.

SPECIMENS AND PROCEDURE

The specimen used for this investigation was a 17ST aluminum-alloy plate 1.062 inches thick by 55 inches square and having a hole 8 inches in diameter bored in it, as shown in figure 1. This plate is the same plate used in the previous investigation reported in reference 7. The center of this hole was on the center line in one direction and 20 inches from the edge of the plate in the other direction. The hole was made 8 inches in diameter primarily to have the diameter of the hole relatively large compared with the 1/2-inch gage length of the Huggenberger tensiometers and secondarily so that the tensiometers could be placed inside the hole.

Figure 2 shows the method used to support and load the plate. The plate was supported on a span length of 36 inches, and line loads were applied 6 inches from the supports so as to subject the middle 24 inches of the plate to a uniform bending moment. Two increments of load were applied to the plate through the distributing system by means of a lever arrangement and standard 50-pound weights. Every effort was made to have the load uniformly applied across the entire width of the plate, but this condition was only partly realized because of local irregularities in the plate.

It was originally proposed to test the plate with the hole in the center of the span and at the center of the width, and then to repeat the test with the plate turned at right angles so as to throw the hole off-center transversely but still maintain it at the center of the span. The plate was warped to such an extent, however, that the first test could not be satisfactorily made. In the test that was made, strains were measured on both sides of the plate at the various gage lines shown in figure 3, with Huggenberger tensiometers on 1/2-inch and 1-inch gage lengths. In the immediate vicinity of the hole, strains were measured over 1/2-inch gage lines; at stations removed from the hole, the strains were measured over 1-inch gage lines. Deflection readings were taken by means of a dial gage, graduated to 0.001 inch, relative to a floor grid independent of the frame supporting the plate. The locations of the various deflection stations are shown in figure 4. Both deflection and strain measurements were taken for two different loads. Figures 5 and 6 are photographs of the plate in the process of being tested.

RESULTS AND DISCUSSION

Throughout this report, strains and the corresponding stresses, measured parallel to axis Y-Y (fig. 7), are referred to as "transverse" strains and stresses, and those measured at right angles to this axis, as "longitudinal" strains and stresses.

The strains measured at the various stations, which consisted of two intersecting gage lines shown in figure 3, were converted into terms of stress in accordance with the biaxial stress relationships:

$$\sigma_L = (\epsilon_L + \mu\epsilon_T) \frac{E}{1 - \mu^2}$$

and

$$\sigma_T = (\epsilon_T + \mu\epsilon_L) \frac{E}{1 - \mu^2}$$

where

- σ_L is longitudinal stress, pounds per square inch.
- σ_T , transverse stress, pounds per square inch.
- ϵ_L , measured longitudinal strain, inch per inch.
- ϵ_T , measured transverse strain, inch per inch.
- μ , Poisson's ratio (1/3 for 17ST aluminum alloy).
- E , modulus of elasticity, 10,300,000 pounds per square inch.

In the cases for which strains were measured over four intersecting gage lines, the directions and the magnitudes of the principal stresses were determined by the dyadic circle method (reference 8).

As previously mentioned, load was applied to the plate in two increments. The loads of 2,100 and 3,300 pounds applied to the end of the loading lever subjected the plate to maximum bending moments of 24,320 and 38,220 inch-pounds, respectively, uniform over the middle 24 inches of the span. All of the data presented in this report, unless specifically indicated as being otherwise, are those determined when the plate was subjected to a constant bending moment of 38,220 inch-pounds.

Figure 8 shows the stresses measured at all the stations on the top and the bottom surfaces of the plate. All stresses measured on the top of the plate were compression, and those on the bottom were all tension. Figure 8 shows that the maximum tangential stresses at the edge of the hole are the stresses normal to the transverse axis. With few exceptions, the magnitudes of the stresses measured at corresponding locations on opposite surfaces of the plate differed from each other by not more than 500 pounds

per square inch and, in most cases, the differences were less. One notable exception is the compressive stress of 6,200 pounds per square inch measured on the top of the plate at station D-6 (fig. 3) as compared with a tensile stress of 6,950 pounds per square inch measured at the corresponding station on the bottom of the plate. Figure 9, which shows the measured stresses at stations D-4 and D-6 plotted against the load on the loading lever, indicates that the magnitude of the stress on the top of the plate at station D-6 was very probably about 6,750 pounds per square inch instead of the measured value of 6,200 pounds per square inch.

Figure 10 shows the distribution and the magnitude of the longitudinal stresses along the transverse center line. For the sake of simplicity, the magnitudes of the stresses measured on opposite surfaces of the plate have been averaged and these average values have been plotted. On one side of the hole, the maximum stress was 6,850 pounds per square inch and, on the other side, 6,860 pounds per square inch. From the close agreement of these two stress values it is evident that the difference in the edge distances had no appreciable effect on the magnitude of the maximum stress at the edge of the hole. In other words, this agreement indicates that, if the plate had been turned 90° so as to have the hole in the center in both directions, the maximum stresses would have been the same as those measured in the case investigated.

Goodier (reference 6) has shown that the tangential and the radial stresses at any point in a plate of infinite width containing an open circular hole and subjected to uniform bending moment normal to the plane of the plate may be expressed as follows:

$$f_r = \frac{M}{2Z} \left[(1+\mu) \left(1 - \frac{a^2}{r^2} \right) - (1-\mu) \left(1 - \frac{4\mu}{3+\mu} \times \frac{a^2}{r^2} - 3 \frac{1-\mu}{3+\mu} \times \frac{a^4}{r^4} \right) \cos 2\theta \right] \quad (1)$$

$$f_\theta = \frac{M}{2Z} \left[(1+\mu) \left(1 + \frac{a^2}{r^2} \right) + (1-\mu) \left(1 + \frac{4\mu}{3+\mu} \times \frac{a^2}{r^2} - 3 \frac{1-\mu}{3+\mu} \times \frac{a^4}{r^4} \right) \cos 2\theta \right] \quad (2)$$

where

f_r is radial stress, pounds per square inch.

f_θ , tangential stress, pounds per square inch.

- M, applied bending moment per inch of width, inch-pounds per inch.
- Z, section modulus of plate per inch of width, in.³ per inch.
- a, radius of hole, inches.
- r, radial distance from the center of hole, inches.
- θ, angle between transverse center line and line along which r is measured, as shown in figure 7.

Equation (1) shows that, at all points at the edge of the hole (r = a), the radial stress is zero and approaches a definite limiting value at r = ∞. Obviously, this equation is inapplicable to a plate of finite width because, in this case, the radial stress is zero at the edge of the plate as well as at the edge of the hole. Equation (2) shows that the tangential stress has minimum values when r = a and θ = 90° and 270°, and maximum values when r = a and θ = 0° and 180°. In other words, the maximum tangential stress at the edge of the hole is normal to the transverse center line, and the minimum tangential stress is normal to the longitudinal center line. When r = a and θ = 0° or 180°, equation (2) reduces to

$$f_{\theta \max} = \frac{M(1 + \mu)(5 - \mu)}{Z(3 + \mu)}$$

where

$f_{\theta \max}$ is the maximum tangential stress at edge of hole, pounds per square inch.

For aluminum, the foregoing expression reduces to 1.87M/Z and for steel to 1.83M/Z or 1.85M/Z, depending on whether a value of 0.25 or 0.30 is used for Poisson's ratio.

The computed maximum fiber stress across the gross section of the test plate, when subjected to a bending moment of 38,220 inch-pounds, was 3,700 pounds per square inch and, on the basis of this value, the maximum measured stress of 6,850 (fig. 10) indicates that the stress-concentration factor at the edge of the hole was 1.85.

This experimentally determined value of stress-concentration factor differs from the theoretical value for an infinite plate by only 1 percent. Goodier's expression for stress concentration at the edge of a circular hole in a plate of infinite width subjected to uniform bending normal to the plane of the plate is evidently applicable, with no appreciable error, to plates of finite width in which the edge distances are at least 2-1/2 times the diameter of the hole. For the particular plate tested, the stress-concentration factor based on the computed stress on the net section was 1.59. Obviously, as the ratio of the width of the plate to the diameter of the hole is increased, the stress-concentration factor based on the computed stress on the net section approaches a value of 1.87 as a limit.

The stress-distribution curve on the right of figure 10 shows that the magnitude of the longitudinal stresses along the transverse center line falls off rapidly and, at a distance of 2.5 times the radius of the hole from the center of the hole, the stress reaches a value that, for all practical purposes, remains constant to the edge of the plate. The distribution curve on the left of figure 10 is similar to that on the right for a distance of about 9 inches from the center of the hole, but the stress reaches a minimum value at a point about 17 inches from the center of the hole and then gradually increases from this point to the edge of the plate. Figure 10 also shows Goodier's theoretical distribution of longitudinal stress along the transverse center line, for a plate of infinite width. A summation of the areas under the two curves shows that the theoretical stress distribution accounts for 97.5 percent of the applied external moment and that the measured stress distribution accounts for only 93 percent of the external moment. An inspection of the two curves shows that a large part of this difference results from the fact that a part of the measured distribution curve dips down to a minimum value between the edge of the hole and one edge of the plate. It is probable that this low stress area may have been the result of unavoidable irregularities in loading. When the plate was subjected to very light loads, the loading rollers made a nonuniform contact across the plate, contact between the plate and roller occurring only at the high spots on the plate. Even when the full load was applied, at a number of points the rollers did not make contact with the plate.

Figure 11 shows the magnitude and the distribution of

the measured transverse stresses along the transverse center line of the plate. These stresses are obviously zero at the edges of the plate and at the edge of the hole. Between the edge of the hole and the edge of the plate nearest to the hole (edge distance = $2\frac{1}{2}$ x diameter), the stress reached a maximum value at a distance of about one diameter from the center of the hole; whereas, between the edge of the hole and the edge of the plate farthest from the hole (edge distance = $4\text{-}3/8$ x diameter), the maximum stress occurred at a distance of about two diameters from the center of the hole. Figure 11 also shows the computed transverse stress distribution for a plate of infinite width. The measured stress curve and the computed stress curve are in reasonable agreement on both sides of the hole up to the point where the stress in the plate of finite widths begins to decrease; that is, for a distance of one or two diameters from the center of the hole, depending on the edge distance.

The distribution of the longitudinal stresses along the longitudinal center line is shown in figure 12. The longitudinal stress is zero at the edge of the hole and approaches a stress value equal to the stress in a solid plate at the load line. The curve for the infinite plate differs from the curve for the plate of finite width in that it is steeper near the edge of the hole and flattens out more rapidly.

Figure 13 shows the distribution of transverse stresses along the longitudinal center line. At the edge of the hole, the measured stresses in the 55-inch wide plate were about 12 percent higher than the computed stresses for an infinite plate. The maximum values of transverse stress measured along the longitudinal center line were about 2.6 times the stress that would exist at the same point in a solid plate. In any event, both the longitudinal and the transverse stresses along the longitudinal center line are of small importance because the maximum stress at any point along this line is only as high as the stresses in a solid plate at the load line.

Figure 14 shows the stress distribution through the thickness of the plate at stations D-4 and D-6 (fig. 3). The values plotted are the average of the stresses measured at the two stations. The distribution of the stress through the thickness of the plate is seen to be linear. These data were obtained from strain measurements taken inside the hole with tensiometers having knife edges about

0.08 inch wide; hence, the actual position of the gage line with respect to the surface of the plate was not definitely known. In all probability, however, the actual position of the gage line did not differ from the points plotted by more than 1/32 inch.

The deflections of the plate along various longitudinal sections are shown in figure 15. Figure 16 shows that all points along any transverse section deflected practically the same amount. In figure 17 the deflections measured along the longitudinal sections 3-3 and 5-5, which are tangent to the edge of the hole, and the deflections measured along the longitudinal center line have been compared with computed deflection values. The deflections measured along section 3-3 were, within the limits of measurement error, equal to the deflections measured along section 5-5 and, consequently, in figure 17 only the average curve for these two sections has been plotted. Figure 17 shows that the measured deflections along the three sections agreed with the computed deflections to within a few thousandths of an inch. The computed deflections were determined from Goodier's expression (reference 6) for the deflection of an infinite plate containing an open circular hole and subjected to uniform bending normal to the plane of the hole:

$$w = - \frac{M}{2EI} \left[x^2 - b^2 + \frac{1 + \mu}{1 - \mu} a^2 \log \frac{r}{b} - \frac{1 - \mu}{3 + \mu} a^2 (1 + \cos 2\theta) + \frac{1}{2} \times \frac{1 - \mu}{3 + \mu} a^2 \left(\frac{a^2}{b^2} + \frac{a^2}{r^2} \cos 2\theta \right) \right]$$

where

w is deflection, inches.

E, plate modulus = $\frac{E}{1 - \mu^2}$

I, moment of inertia of plate per inch of width, in.⁴ per inch.

x, distance along X axis (fig. 7) from center of hole to point considered, inches.

b, one half the length of the section under constant bending moment, inches (a << b).

The agreement between the measured and the computed deflections (fig. 17) indicates that Goodier's expression for the deflection of infinite plates in the vicinity of the hole is applicable, without a significant error, to the plates of finite width in which the length under constant bending moment is as short as three times the diameter of the hole.

Figure 18 shows a comparison between the measured deflections at sections 3-3 and 5-5, and the computed deflection of a solid plate using a value of 11,600,000 pounds per square inch for the plate modulus. From this figure, it is evident that the maximum deflection of the plate containing an open circular hole was about 20 percent greater than the computed maximum deflection of a solid plate of the same size loaded in the same manner.

CONCLUSIONS

The foregoing results and discussion pertaining to a plate containing an open circular hole, whose diameter is relatively large compared with the thickness of the plate and subjected to uniform bending normal to the plane of the plate may be summarized as follows:

1. Stress concentrations occurred at the edge of the hole, the maximum stresses being tangential to the hole at the ends of the transverse diameter.

2. The maximum stress at the edge of the hole was 1.59 times the computed stress on the net section and 1.85 times the computed stress in a solid plate of the same dimensions subjected to the same bending forces.

3. The smallest edge distance was equal to $2-1/2$ times the diameter of the hole, and the stress concentration on this side of the hole was the same as on the side where the edge distance was about $4-1/2$ diameters.

4. A theoretical analysis of the problem shows that, for an aluminum plate of infinite width, the stress concentration at the edge of the hole would be 1.87 times the stress in a solid plate, which is substantially the same relation obtained on the plate tested.

5. From the foregoing, it may be concluded that the

stress-concentration factor based on gross area would be the same for any width of plate provided that the edge distance was at least $2\frac{1}{2}$ diameters.

6. The maximum deflections were about 20 percent greater than the corresponding deflection for a solid plate of the same size subjected to the same bending forces.

Aluminum Company of America,
Aluminum Research Laboratories,
New Kensington, Pa., July 21, 1939.

REFERENCES

1. Frocht, Max M.: Factors of Stress Concentration Photo-
elastically Determined. Jour. Appl. Mech., vol. 2,
no. 2, June 1935, pp. A-67 - A-68.
2. Wahl, A. M., and Beunwkes, R., Jr.: Stress Concentra-
tion Produced by Holes and Notches. A.S.M.E. Trans.,
APM-56-11, vol. 56, no. 8, Aug. 1934, pp. 617-625.
3. Tuzi, Ziro: Effect of Circular Hole on the Stress
Distribution in a Beam under Uniform Bending Moment.
Phil. Mag., ser. 7, vol. IX, no. 56, Feb. 1930, pp.
210-224.
4. Howland, R. C. J.: On the Stresses in the Neighbor-
hood of a Circular Hole in a Strip under Tension.
Phil. Trans. Roy. Soc. (London), ser. A, vol. 229,
Jan. 6, 1930, pp. 49-86.
5. Howland, R. C. J., and Stevenson, A. C.: Biharmonic
Analysis in a Perforated Strip. Phil. Trans. Roy.
Soc. (London), ser. A, vol. 232, June 2, 1933, pp.
155-222.
6. Goodier, J. N.: The Influence of Circular and Ellip-
tical Holes on the Transverse Flexure of Elastic
Plates. Phil. Mag., ser. 7, vol. XXII, no. 145,
July 1936, pp. 69-80.
7. Moore, R. L., and Sturm, R. G.: The Behavior of Rec-
tangular Flat Plates under Concentrated Loads.
Jour. Appl. Mech., vol. 4, no. 2, June 1937, pp.
A-75 - A-85.
8. Osgood, William R., and Sturm, Rolland G.: The Deter-
mination of Stresses from Strains on Three Inter-
secting Gage Lines and Its Application to Actual
Tests. Res. Paper No. 559, Bur. Standards Jour.
Res., vol. 10, no. 5, May 1933, pp. 685-692.

N.A.C.A. Technical Note No. 740

Fig. 1

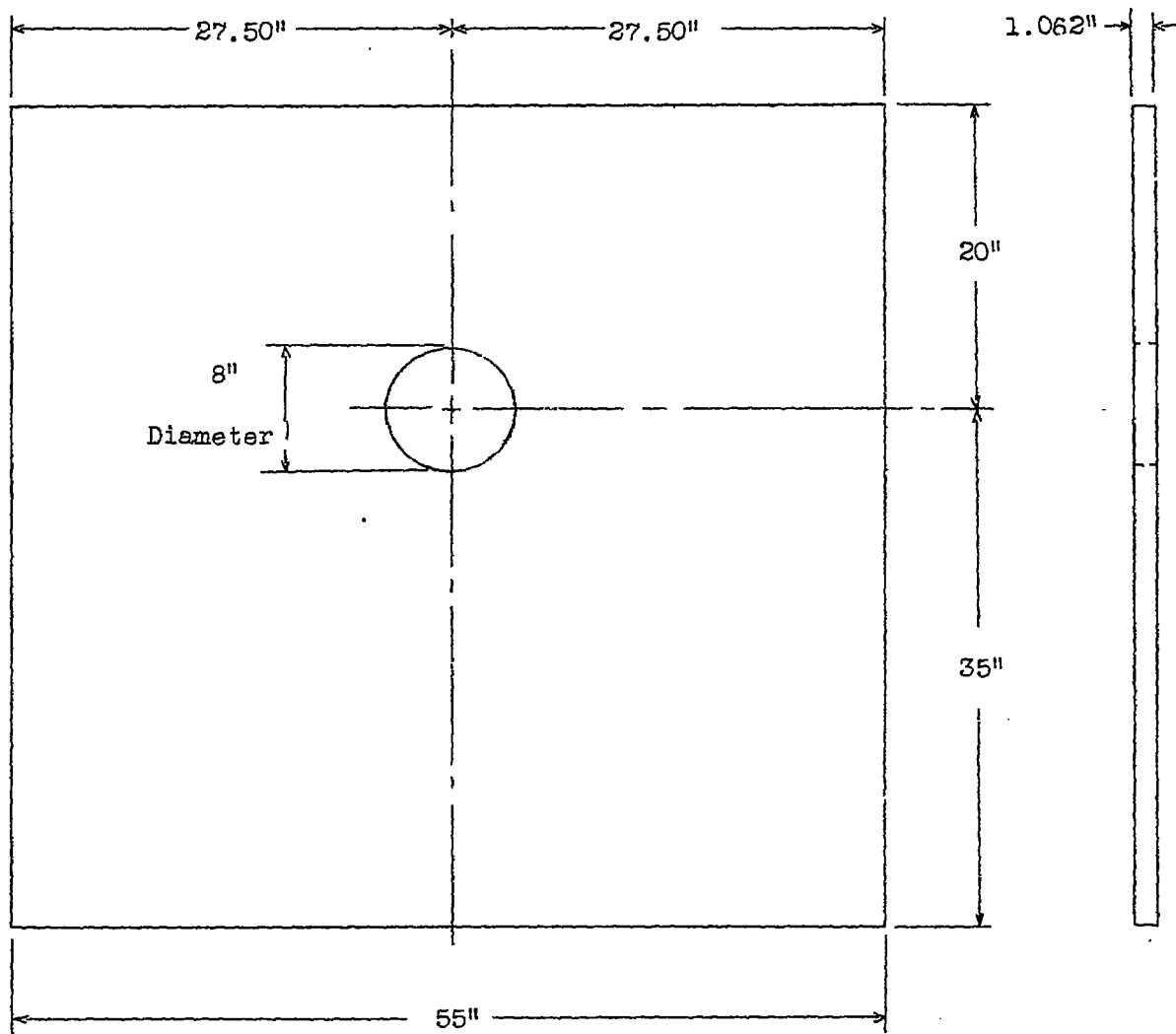

Figure 1.- Detail of plate specimen.

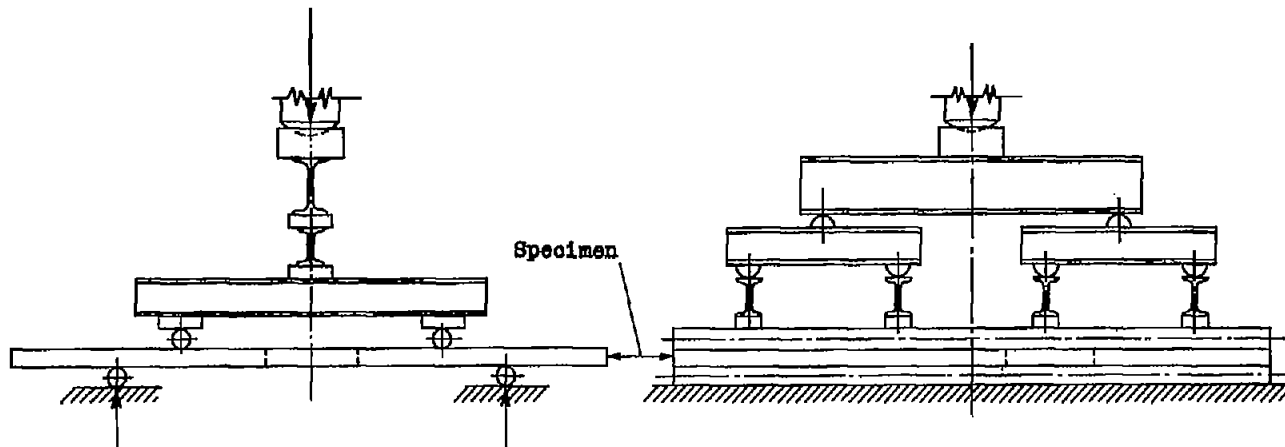

Figure 3.- Method used to support and load plate.

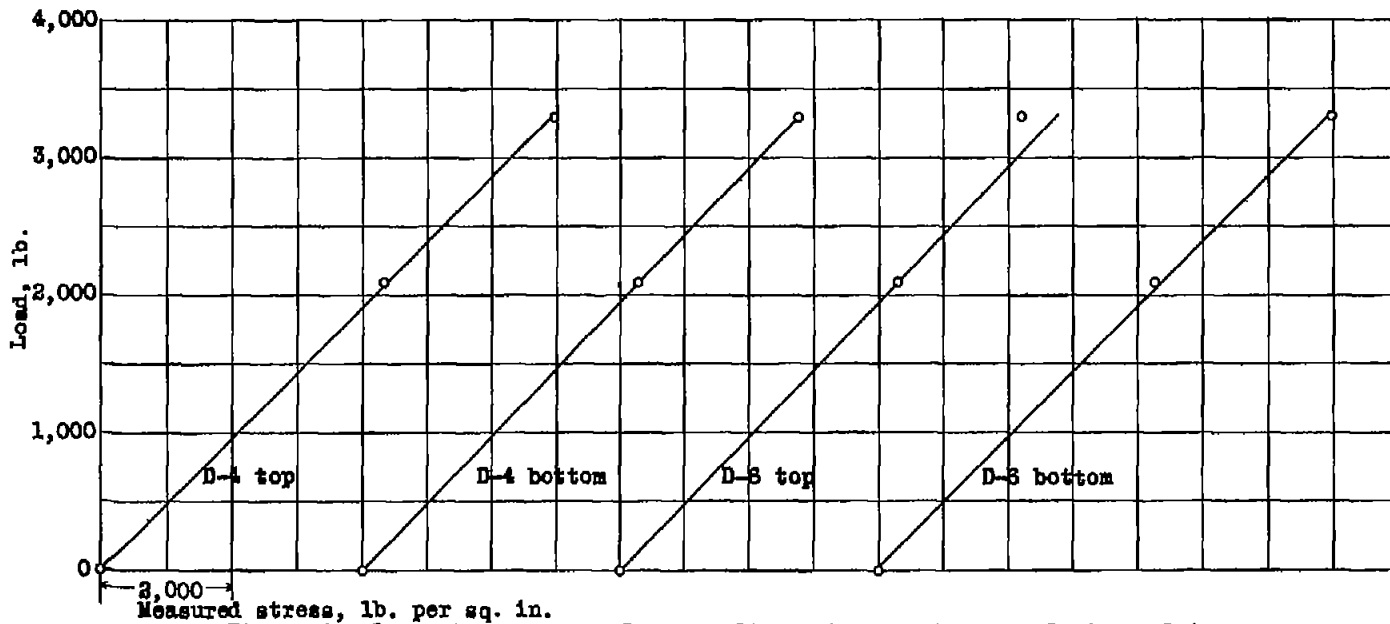

Figure 9.- Load-stress curves for gage lines at edge of open hole in a plate.

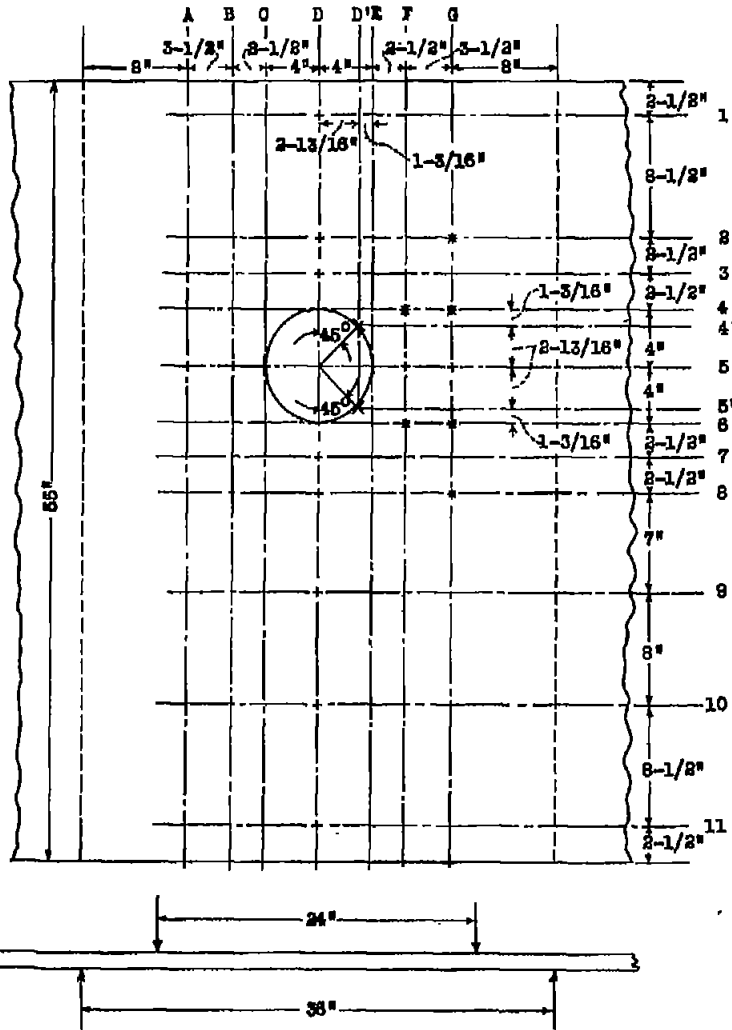

Figure 3.- Location of strain-measurement stations.

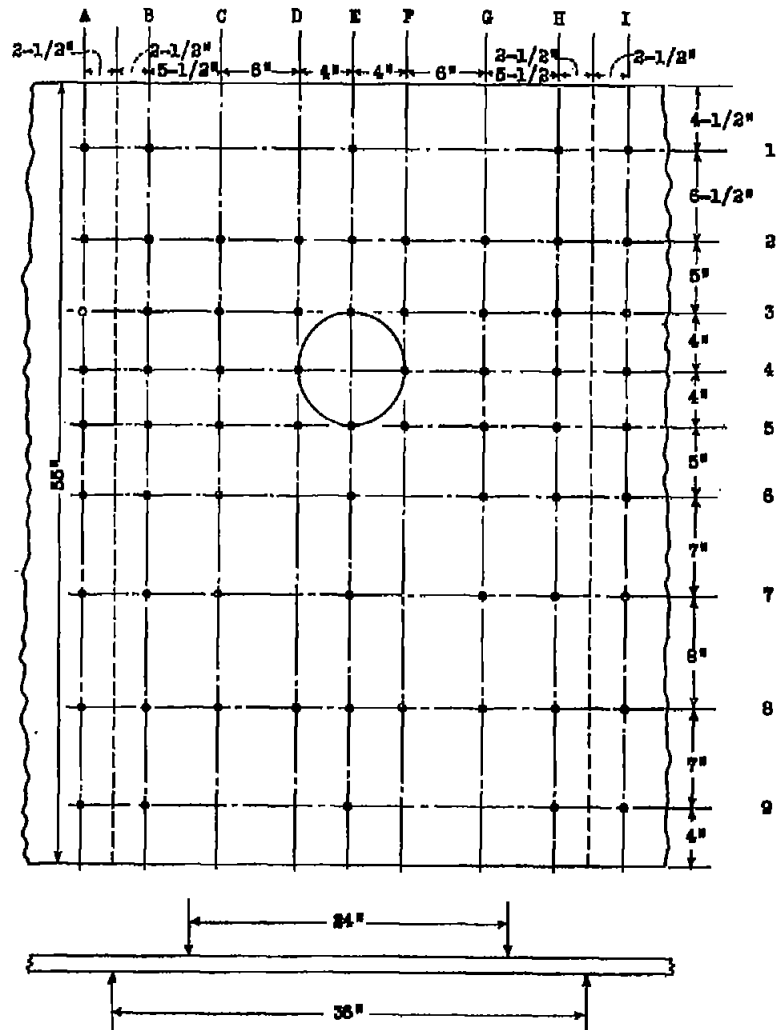

Figure 4.- Location of deflection-measurement stations.

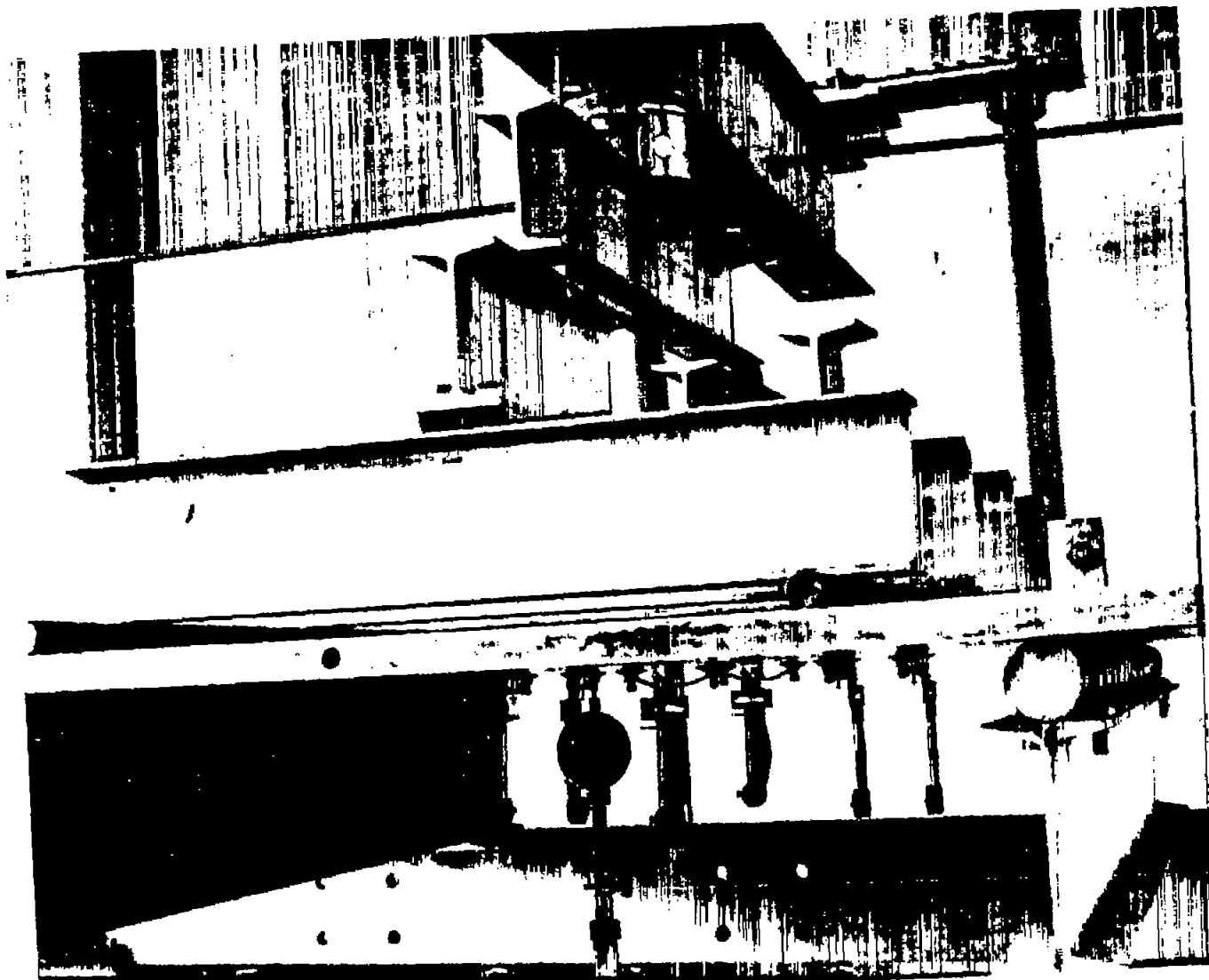

Figure 5. View of plate test showing Huggenberger tensiometers attached to bottom of plate and dial gage used for measuring deflection.



Figure 6.- View of plate test showing Huggenberger tensiometer attached to top of plate and inside of hole.

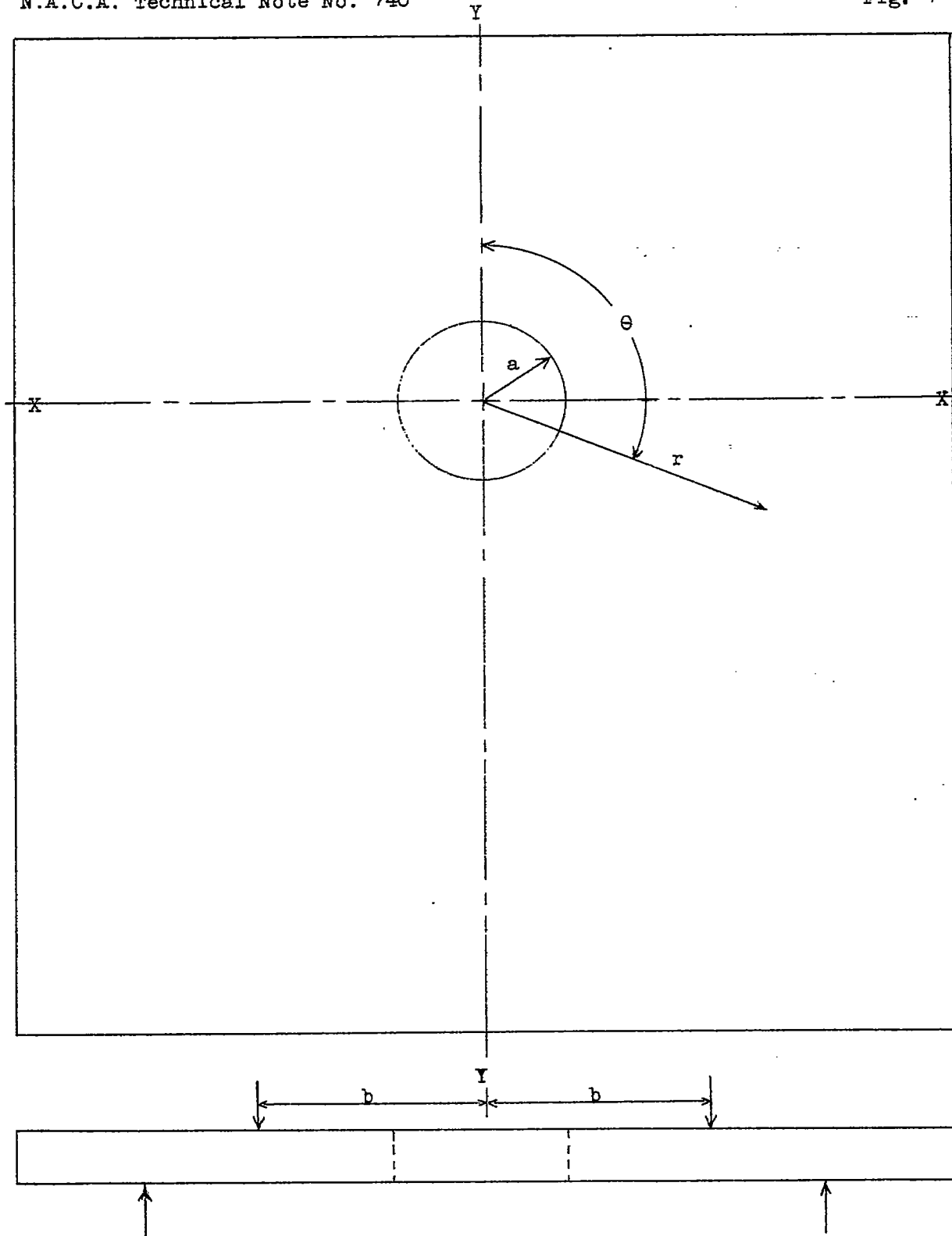

Figure 7.- Coordinate axes of plate..

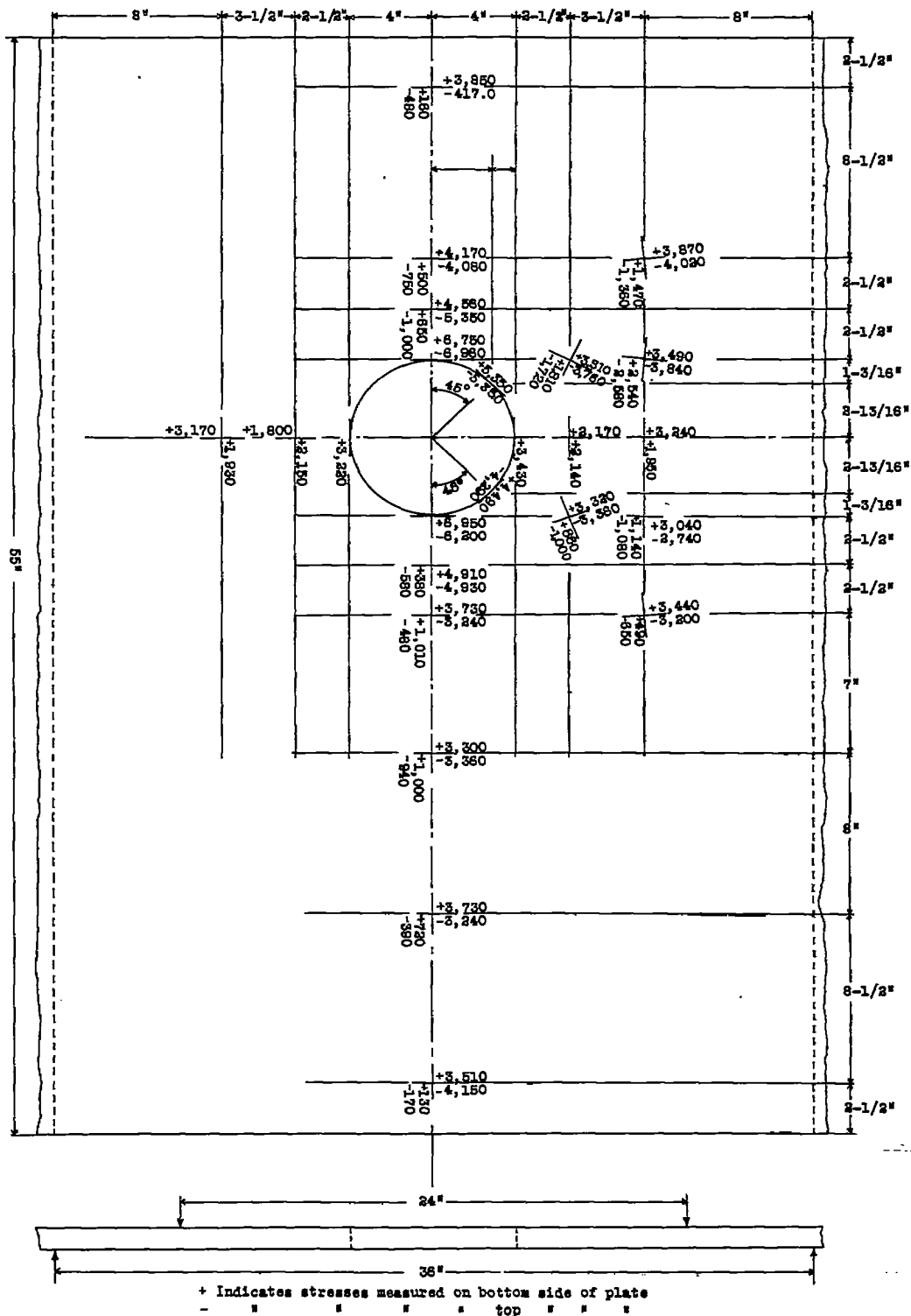

Figure 8.- Stresses measured at various locations on plate.

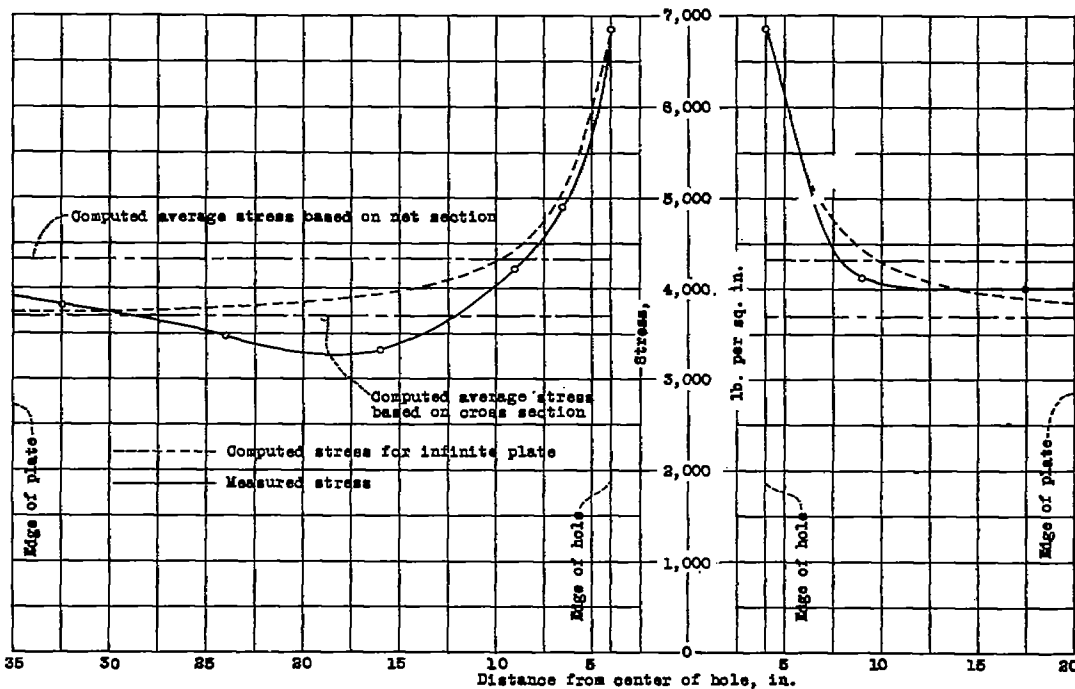

Figure 10.- Longitudinal stress along Y-Y (transverse center line) of plate with open hole.

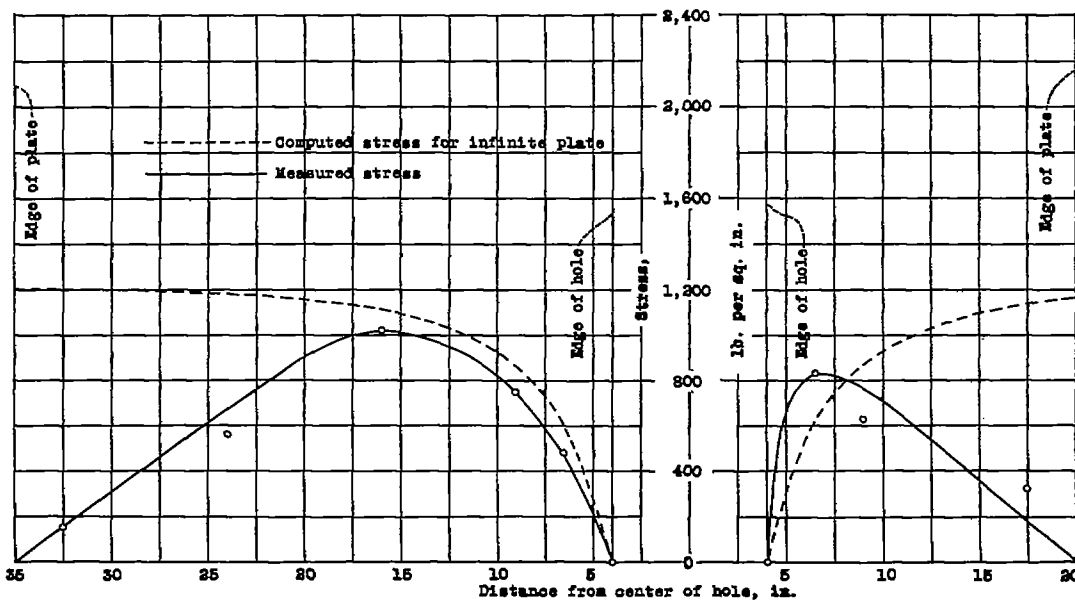

Figure 11.- Transverse stress along Y-Y (transverse center line) of plate with open hole.

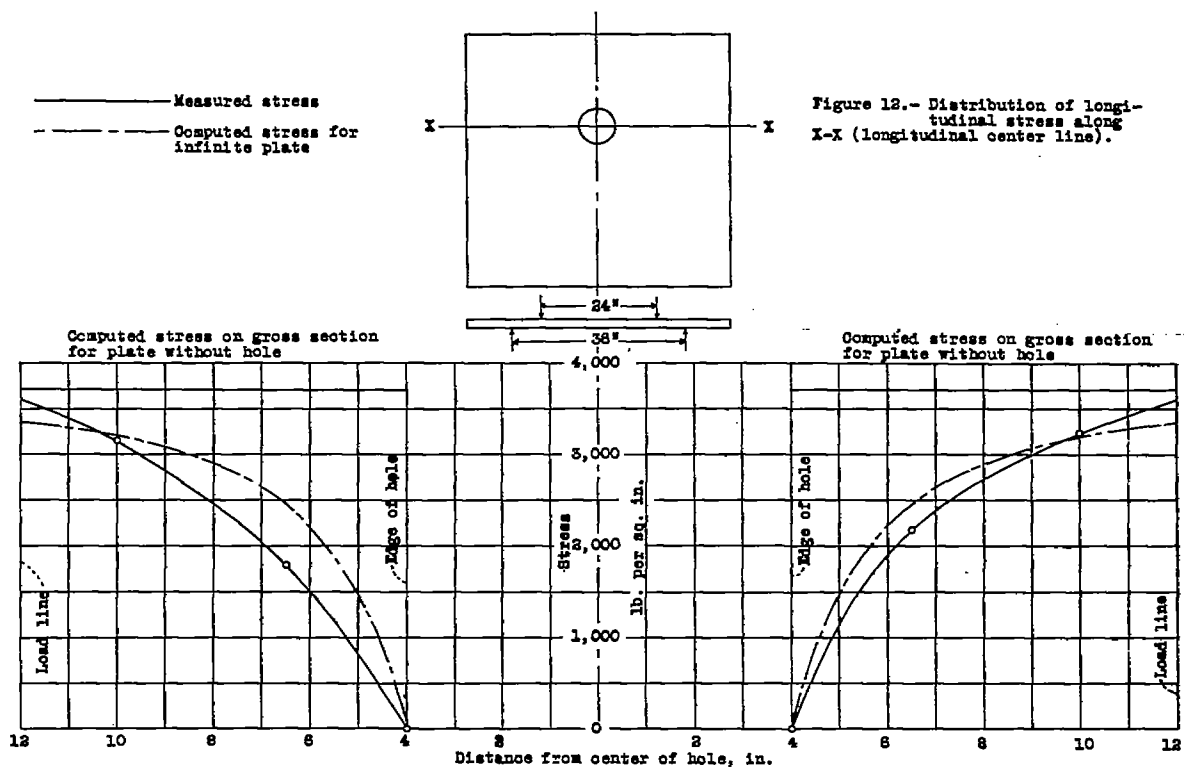

Figure 12.- Distribution of longitudinal stress along X-X (longitudinal center line).

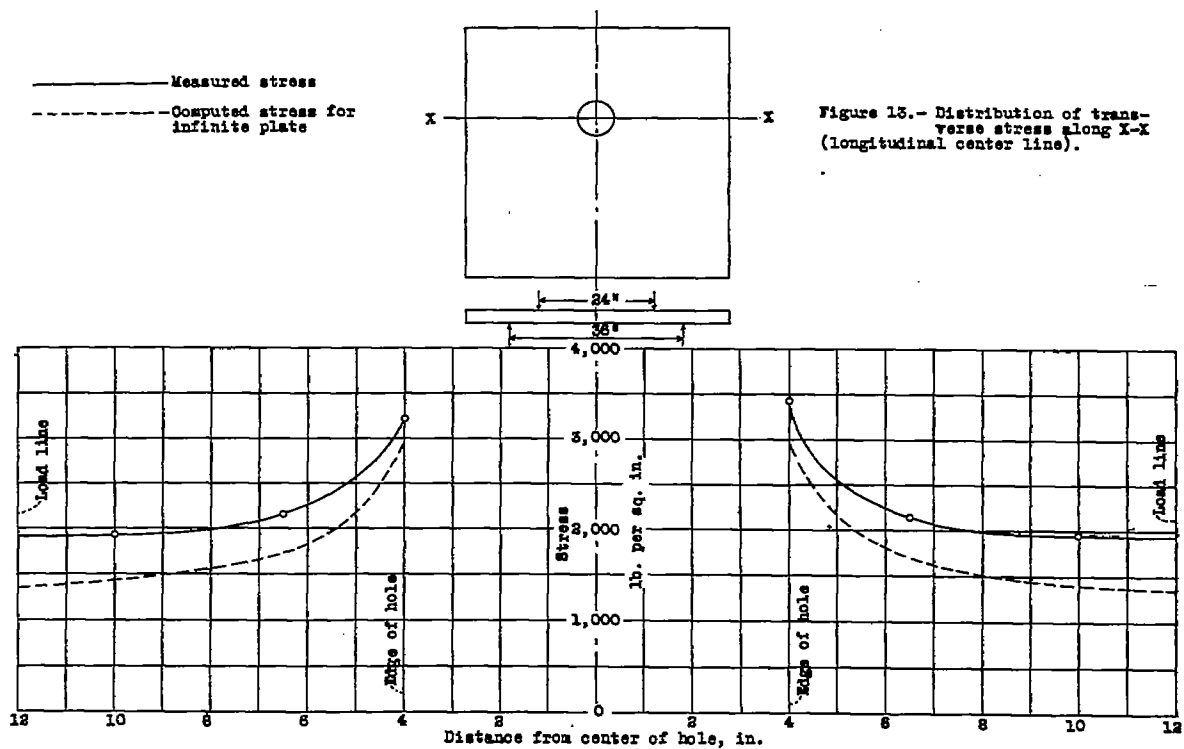

Figure 13.- Distribution of transverse stress along X-X (longitudinal center line).

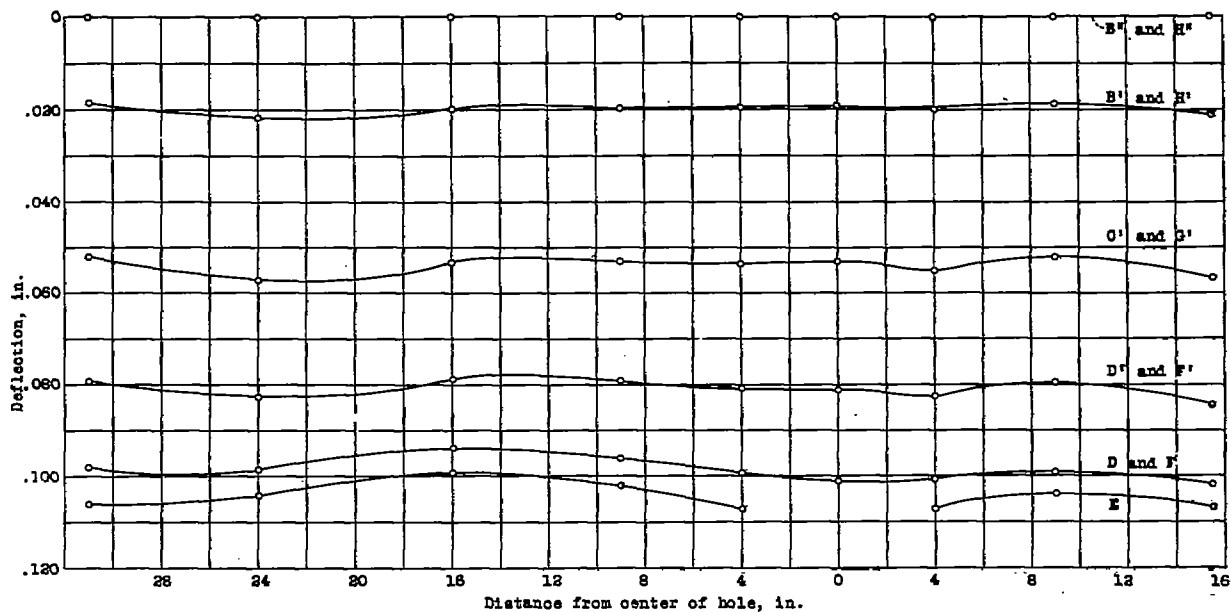

Figure 16.- Transverse deflection curves of plate with open hole.

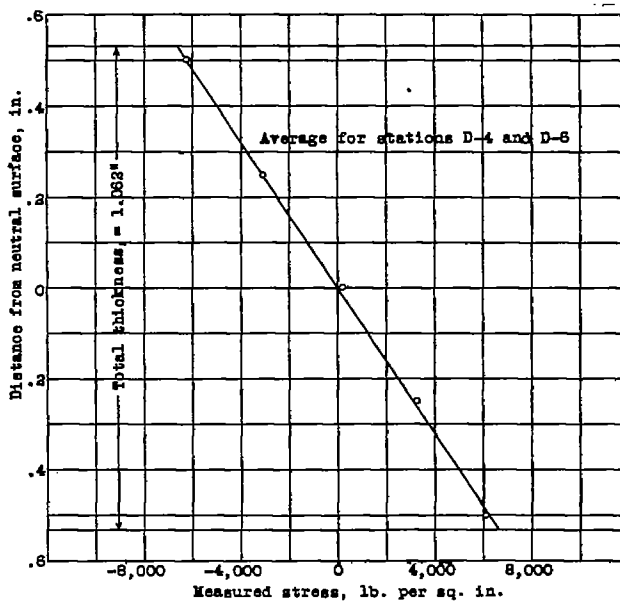
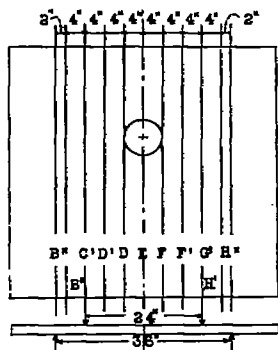

Figure 14.- Stress distribution through thickness of plate.

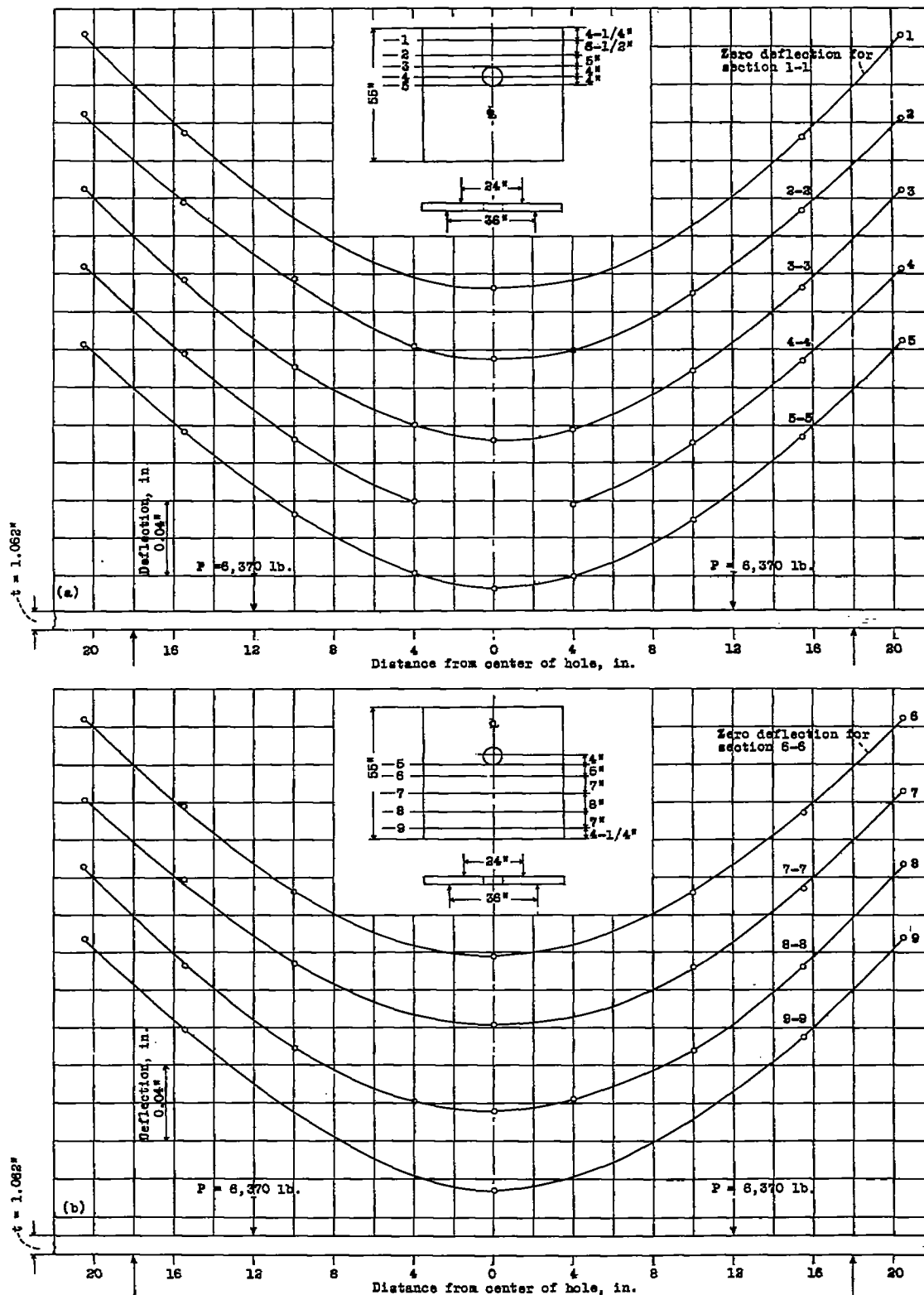

Figure 15 a and b.- Deflection curves for plate with open hole.

