

NIA CIA
CLASSIFICATION CANCELLED

THIS DOCUMENT PROVIDED BY THE ABBOTT AEROSPACE
TECHNICAL LIBRARY
ABBOTTAEROSPACE.COM

MAR 17 1943

~~CONFIDENTIAL~~

TECHNICAL NOTES
NATIONAL ADVISORY COMMITTEE FOR AERONAUTICS

No. 888

TORSION OF FLANGED MEMBERS WITH CROSS SECTIONS
RESTRAINED AGAINST WARPING

By H. N. Hill
Aluminum Company of America

CLASSIFIED DOCUMENT

This document contains classified information affecting the National Defense of the United States within the meaning of the Espionage Act, USC 50:31 and 32. Its transmission or the revelation of its contents in any manner to an unauthorized person is prohibited by law. Information so classified may be imparted only to persons in the military and naval Services of the United States, appropriate civilian officers and employees of the Federal Government who have a legitimate interest therein, and to United States citizens of known loyalty and discretion who of necessity must be informed thereof.

FILE COPY

To be returned to
the files of the Langley
Memorial Aeronautical
Laboratory.

Washington
March 1943

NATIONAL ADVISORY COMMITTEE FOR AERONAUTICS

TECHNICAL NOTE NO. 888

TORSION OF FLANGED MEMBERS WITH CROSS SECTIONS
RESTRAINED AGAINST WARPING

By H. N. Hill

SUMMARY

The longitudinal stresses and the stiffness of flanged members-I-beams, channels, and Z-bars - were investigated when these members were subjected to torque with constraint against cross-sectional warping. Measured angles of rotation agreed with corresponding calculated values in which the torsion-bending factor of the cross section was involved; the agreement was better for the I-beam and the Z-bar than for the channel. Longitudinal stresses measured at the mid-span were found to agree with the calculated values that involved unit warping as well as the torsion-bending factors; the channel showed the greatest discrepancy between measured and calculated values. When commonly given expressions for rotations and maximum longitudinal stresses in a twisted I-beam were applied to the channel and to the Z-bar, values were obtained that were in reasonably good agreement with values obtained by the method involving the torsion-bending constant and unit warping.

INTRODUCTION

When pure torque is applied to a flanged member, such as an I-beam, a channel, or a Z-bar, twisting is accompanied by warping of the cross sections. If one or more cross sections are restrained against such warping, longitudinal stresses are set up that are generally associated with bending of the flanges. In some instances these stresses become quite large and have an appreciable effect on the torsional stiffness of the member. A knowledge of the torsional stiffness is essential in determining the stability of a member against torsional buckling under axial compression or against lateral buckling under beam loading.

Because of the symmetry of the cross section, the longitudinal stresses resulting from restraint against cross-

sectional warping in a twisted I-beam are confined to the flanges. The stresses may be considered as being produced by bending of the flanges in their own planes. In the case of an unsymmetrical section, such as a channel or a Z-bar, longitudinal stresses occur in the web as well as in the flanges. In such cases the stress distribution cannot be determined by considering only bending of the flanges.

The solution to the problem of the twisting of I-beams, with restraint against cross-sectional warping, may be obtained from many sources. (See, for example, references 1 to 3.) Treatments of the same problem involving flanged members of unsymmetrical cross section are not so numerous, although some authorities (references 1 and 2) state that the formulas for longitudinal stresses and angles of twist obtained for the I-beam are also applicable to channels or to Z-bars. The case of a channel has been handled by considering the cross section as composed of two angles that are constrained to bend about certain axes (reference 4). A method for evaluating the longitudinal stresses and angle of twist for a member of any "open section" is contained in the works of Wagner (references 5 and 6) and Kappus (reference 7).

Experimental studies of the effect of cross-sectional constraint on the behavior of flanged members under torsion (references 3 and 4) have been rather meager.

The tests herein reported were made for the purpose of studying the longitudinal stresses and the stiffness of I-beams, channels, and Z-bars, subjected to torque, with constraint against cross-sectional warping.

MATERIAL

The material available for these tests consisted of two pieces of high-strength aluminum-alloy extruded I-beam about 66 inches long. The cross section was the same for both beams; that is, the nominal dimensions were: depth, $2\frac{1}{2}$ inches; flange width, 2 inches; and thickness of both flanges and web, $\frac{1}{8}$ inch. One piece was of 24S-T alloy while the other was of X74S-T alloy. This material was used because it had been left over from previous investigations (reference 8) and was immediately available. Because the tests made in this investigation were confined to the elastic range of the material, values of modulus of elasticity and

of proportional limit are the only mechanical properties of immediate concern. The following modulus values have been used in analyzing the test results and in the ensuing calculations:

Alloy	Young's modulus, E (lb/sq in.)	Modulus of rigidity, G (lb/sq in.)
24S-T	10,500,000	3,920,000
X74S-T	10,300,000	3,860,000

Previous tests had indicated that the proportional limits in tension and compression for both materials exceeded 25,000 pounds per square inch.

The piece of X74S-T alloy was first tested as an I-beam. The material of both flanges on one side of the web was then machined away, and a specimen of channel cross section was left. The piece of 24S-T I-beam was reduced to a Z-bar by machining away the material of the two flanges on opposite sides of the web. The dimensions of the various cross sections, as obtained by measurement, are shown in figure 1.

TESTING APPARATUS AND PROCEDURE

The specimens were subjected to a torque applied at the middle of an unsupported length of $64\frac{1}{2}$ inches. The general arrangement of the test setup and the method of applying torque are clearly shown in figure 2. The diameter of the loading disk is 9.75 inches. A load of 100 pounds therefore corresponded to a torque of 488 inch-pounds. The load was applied in increments of 20 pounds; the loading bar and load pan constituted the first increment. A total load of 160 pounds (780 in.-lb) was applied to the I-beam and a maximum load of 100 pounds (488 in.-lb) was applied to the channel and to the Z-bar.

The manner in which the ends of the specimens were supported can be seen in figures 3 and 4. An opening $2\frac{1}{8}$ inches wide by $2\frac{1}{2}$ inches deep was cut in each supporting bracket. Filler blocks were then cut and carefully fitted

to accommodate the shape of the specimen. The photographs show filler blocks in place for the Z-bar. Similar blocks were used to accommodate the I-beam and the channel. As can be seen in figure 4, the edges of the opening and of the filler block that bore on the specimen were chamfered to provide a bearing about 1/32 inch wide. The corners of these bearing edges were slightly rounded. A graphite bearing grease was placed on the bearing surfaces to minimize the friction that might develop when the specimen was twisted. The object of this type of end support was to provide restraint against twisting without constraining the end sections against warping. That this objective was practically attained was indicated by the small bending stresses measured in the flanges near the ends of the I-beam. (See fig. 11.) The same method was used for mounting the loading disk at the middle of the specimen, with the exception that the bearing surfaces on the opening and the filler blocks were the full thickness of the disk (1/4 in.). The two halves of the specimen reacted against each other under torque to prevent the middle cross section from warping.

Strains were measured on both edges of the top flange at numerous locations on one-half of each specimen. Measurements were also made at one location on the bottom flange on the same half of the specimen and also at one location on the top flange on the other half. These strains were measured on 1/2-inch gage lengths with Huggenberger tensometers.

Angles of rotation were measured at the middle and both ends of each specimen and at numerous stations along one half. An adjustable protractor and spirit level were used for these measurements. Successive determinations of the angular slope of the top flange could be consistently repeated with a maximum variation of 5 minutes.

ANALYTICAL TREATMENT

The longitudinal stresses resulting from restraint against cross-sectional warping in a twisted member and the angle of rotation depend on a property of the cross section which has been called the torsion-bending factor (references 5 and 9). The differential equation for torsion in such a member can be written (references 5 to 7 and 9 to 11)

$$T = GJ \frac{d\theta}{dx} - E C_{BT} \frac{d^3\theta}{dx^3} \quad (1)$$

where

- T twisting moment
- θ angle of twist
- x distance along axis of shear centers
- G modulus of rigidity
- J section factor for torsion
- E Young's modulus
- C_{BT} torsion-bending factor for section about shear center

For sections composed of narrow rectangles the section factor for torsion J may be determined approximately as the sum of the factors for the individual rectangles. The value may be determined more exactly by equation (21) of reference 3. This exact method was used for the evaluation of the values of J given in figure 1. Corresponding values obtained by the approximate method, with overlapping rectangles considered, were about 5 percent lower for the channel and for the Z-bar and about 10 percent lower for the I-beam than results obtained by the exact method.

A method for evaluating the torsion-bending factor C_{BT} may be found in references 5 to 7 and 11. The factor is defined by the equation

$$C_{BT} = \int u^2 dA \quad (2)$$

where u is the "unit warping" of the area dA from a reference plane through the shear center and normal to the axis, when $d\theta/dx = 1$. Torsion-bending factors C_{BT} for each of the sections involved in this investigation are given in figure 1. The evaluation of the integral of equation (2) for each section is shown in the appendix. For the channel specimen, this evaluation involves location of the shear center of the section.

For pure torque applied at midspan, with the ends of the member free to warp, the solution of equation (1) in the form given in reference 3 is most convenient.

$$\theta = \frac{T}{GJ} \left(x - a \frac{\sinh \frac{x}{a}}{\cosh \frac{L}{2a}} \right) \quad (3)$$

where

$$a = \sqrt{\frac{EC_{BT}}{GJ}} \quad (4)$$

and L is the length of span. In this equation, x varies from 0 at the end of the span to $L/2$ at midspan. The torque T is that existing at the end of the span and is therefore one-half the applied torque. The equation is applicable only to one-half the span.

It has been shown in references 5 to 7 that the longitudinal stresses σ resulting from restraint against cross-sectional warping can be found from the values of unit warping u , by the equation

$$\sigma = -E \frac{d^2\theta}{dx^2} u \quad (5)$$

By substituting the value of θ from equation (3), equation (5) can be expressed as

$$\sigma = \frac{ET}{GJ} \frac{\sinh \frac{x}{a}}{a \cosh \frac{L}{2a}} u \quad (6)$$

The values of the unit warping u needed to solve this equation were obtained in connection with the evaluation of equation (2) to obtain expressions for the torsion-bending factor C_{BT} for the various sections. (See appendix.)

DISCUSSION OF RESULTS

Rotations

The measured rotations agreed very well with corresponding values calculated by equation (3), as can be seen in figures 5, 6, and 7. For the I-beam and for the Z-bar, the rotations measured at midspan were within 2 percent of the calculated values. For the channel, the measured rotation at midspan was about 5 percent lower than calculations indicated.

A comparison of measured rotations with the values indicated by the straight lines in figures 5, 6, and 7 indicates that the restraint against warping was responsible for a decrease in rotation at midspan of about 36 percent for the I-beam and about 23 percent for the channel and for the Z-bar.

The relationship between angle of rotation and applied torque was linear, except for slight deviations at the higher loads (figs. 8, 9, and 10). For these higher loads, at which the angle of twist became quite large (greater than 20°), secondary longitudinal stresses (reference 1) became great enough to produce a slight but noticeable increase in the resistance of the member to twist. At midspan, the maximum deviation from a linear relationship is about 2 percent. The values indicated by the straight lines of figures 8, 9, and 10 were plotted in figures 5, 6, and 7.

In references 1 and 2, it is stated that the equation derived for the rotation of an I-beam under torque, with restraint against cross-sectional warping, is also applicable to a channel. In reference 2, it is also stated that the equation can be used for a Z-bar. For this purpose, the angle of rotation at midspan can be expressed as

$$\theta_M = \frac{T}{GJ} \left(\frac{L}{2} - a \tanh \frac{L}{2a} \right) \quad (7)$$

where

$$a = \frac{h}{2} \sqrt{\frac{E I_y}{GJ}} \quad (8)$$

where h is the depth of section, and I_y is the moment of inertia about the yy axis. (See fig. 1.) The use of this equation for calculating the angle of rotation for the channel and for the Z-bar tested in this investigation gives values that are about 6 percent lower than corresponding values calculated by the more exact method involving the torsion-bending factors for the sections. (See table 1.)

Longitudinal Stresses

The longitudinal stresses measured in the region of midspan on the top flange of the I-beam and of the channel specimens were in very close agreement with corresponding values calculated by equation (6). (figs. 11 and 12.) For the Z-bar, the measured stresses on the top flange at midspan were about 7 percent higher than calculation indicated (fig. 13). Stresses measured on the bottom flange of the I-beam at midspan varied from those measured on the top flange by less than 1 percent. The stresses in the bottom flange of the channel and of the Z-bar were about 8 percent and 10 percent lower, respectively, than corresponding values for the top flange. If an average for top and bottom flanges is considered, the measured and calculated values for longitudinal stress at midspan agreed within about 4 percent and the agreement was poorest for the channel. For all three specimens, the stresses measured on the two halves of the span agreed within the limits of error of the measurements.

As can be seen in figures 12 and 13, the agreement between calculated and measured values of longitudinal stresses was not so good near the ends of the specimens as at midspan. In addition to the longitudinal stresses resulting from restraint against cross-sectional warping, there are secondary longitudinal stresses that exist even in a twisted member without cross-sectional restraint (reference 1). The magnitude of these secondary stresses varies as the square of the rate of twist, that is, as $(d\theta/dx)^2$. For tests of the sort made in this investigation, consequently, there will be no secondary stresses at midspan, that is, $(d\theta/dx = 0)$, and such stresses will attain a maximum value near the ends of the span where $d\theta/dx$ is greatest. The effect of these secondary stresses on the values of the measured stresses is evident in the curves for the channel and for the Z-bar (figs 12 and 13). Figure 11, however, shows close agreement between measured and calculated values of stress for the I-beam for the full length. Because of the symmetry of this section, the stresses measured on the two edges of the flange were

averaged and the effects of the secondary stresses were thus eliminated. That this secondary-stress effect was also present in the I-specimen is shown by the circles in figure 11, which indicate the stresses measured on each edge of the flange.

If the equation obtained for calculating the bending stresses in the flanges of a twisted I-beam is applied to the channel and to the Z-bar, as suggested in reference 2, values of maximum longitudinal stress are obtained that are in surprisingly good agreement with the measured values and also with values calculated according to the more exact method of equation (6). (See table I.) For the I-beam, equation (6) can be expressed as

$$\sigma = \frac{T_{ab}}{hI_y} \tanh \frac{L}{2a} \quad (9)$$

where

$$a = \frac{h}{2} \sqrt{\frac{EI_y}{GJ}}$$

b is the flange width, and the other terms are as previously defined. This equation is obtained by substituting in equation (6) the expressions for C_{BT} and u given in table II (see appendix) and the relationship $I_y = 2 I_{\bar{y}}$. When equation (9) is applied to a channel or to a Z-bar, the term b is defined as twice the distance from the y-axis to the extreme fiber (reference 2).

CONCLUSIONS

The following conclusions were indicated by the results of this investigation of flanged members, I-beam, channel, and Z-bar, subjected to a torque at midspan and supported at the ends in such a way that rotation was prevented without restraining the end cross sections against warping:

1. The measured angles of rotation were in agreement with corresponding values calculated by an equation that

involves the torsion-bending factor of the cross section. The agreement was within 2 percent for the I-beam and for the Z-bar; whereas the measured rotation of the channel was about 5 percent lower than calculations indicated.

2. The longitudinal stresses measured at midspan agreed within about 4 percent with values calculated by an equation that involves unit-warping values as well as the torsion-bending factor. The agreement was poorest for the channel specimen.

3. Commonly given expressions for rotations and maximum longitudinal stresses in a twisted I-beam, in which the effects of restraint against warping are expressed in terms of the lateral moment of inertia, when applied to the channel and to the Z-bar, gave values that were in reasonably good agreement with measured values. The angles of rotation obtained by this approximate method were about 6 percent lower than corresponding values calculated by the more exact method involving the torsion-bending-factors for the sections. The maximum longitudinal stress values thus calculated were about 2 percent lower for the channel and about 5 percent higher for the Z-bar than the values obtained by the exact method.

Aluminum Research Laboratories,
Aluminum Company of America,
New Kensington, Pa., November 20, 1942.

APPENDIX

EVALUATION OF THE TORSION-BENDING FACTOR C_{BT}

The torsion-bending factor for a section depends on the axis about which the section is considered to rotate. For rotation about the shear center, the factor can be expressed (references 5 to 7 and 11)

$$C_{BT} = \int_A u^2 dA \quad (10)$$

where u is the unit warping of the element of area dA from a reference plane through the shear center and normal to the axis, when the angle of twist per unit length ($d\theta/dx$) is unity. (See reference 7.)

The unit warping, which has the dimension of an area, is given by the equation

$$u = u_0 + \int_0^s r_t ds + r_n n \quad (11)$$

where

u_0 unit warping at point on median line of section where $s = 0$

s distance measured along median line from point where $s = 0$

r_t perpendicular distance from center of rotation (shear center in this instance) to a tangent to median line at $s = s$

n distance measured along perpendicular to median line at $s = s$

r_n perpendicular distance from center of rotation (shear center) to perpendicular to median line at $s = s$

The first two terms of equation (11) depict the unit warping of the median line of the section. The last term includes the variation in warping across the thickness of the section. In relatively thin sections, such as tested in this investigation, this last term is relatively unimportant and may generally be neglected. The term u_0 in equation (11) can be evaluated from the expression (reference 7)

$$\int_A u \, dA = 0 \quad (12)$$

By the use of equations (10) to (12), the unit warping and the torsion-bending factors have been derived for the I-beam, the channel, and the Z-bar and expressed in the dimensional notation of figure 14. The dimensions shown in figure 1. have been substituted in these expressions for torsion-bending factor to obtain the values of C_{BT} used in calculating rotations and stresses. The expressions for unit warping have likewise been evaluated for the calculation of the longitudinal stresses by equation (6).

In arriving at the expression for the torsion-bending factor C_{BT} in table II, the last term of equation (11) was neglected. Including this term would slightly increase the value of C_{BT} . The percentage increase would be greatest for the channel section. Inasmuch as the greatest discrepancy between calculated and measured angle of rotation occurred for the channel and inasmuch as the measured rotation was smaller than calculations indicated, it is desirable to determine the effect on the calculated value for the angle of rotation of including the last term of equation (11). It has been shown in reference 5 that the amount C_n to be added to the value already determined for C_{BT} to take account of the warping across the thickness, can be expressed as

$$C_n = \frac{1}{12} \int_0^s t^3 r_n^2 \, ds \quad (13)$$

where t is the thickness and the other terms are as previously defined. Expressed in the dimensional notation of table II, the equivalent expression for the channel is

$$C_n = \frac{1}{144} \left\{ A_W^3 + 24 A_F^3 \left[\frac{1}{3} + \frac{e}{b} + \left(\frac{e}{b} \right)^2 \right] \right\} \quad (14)$$

By substituting in equation (14) the dimensions given in figure 1, C_n for the channel is found to be 0.00042 inch⁶. This value is less than 1 percent of the value of C_{BT} for this section (fig. 1). It is evident then that neglecting the effect of warping across the thickness in determining the torsion-bending constant is certainly justifiable for the sections involved in this investigation.

LOCATION OF THE SHEAR CENTER OF THE CHANNEL SECTION

The expressions for the torsion-bending factor and unit warping for the channel section involve the dimension e which is the distance from the middle of the web to the center of rotation or shear center. An equation for evaluating e can be obtained directly from the expression for the torsion-bending factor. The section will rotate about the center of least resistance, that is, the center for which the torsion-bending factor is a minimum. The location of this center of rotation can be found by setting

$$\frac{dC_{BT}}{de} = 0$$

and solving for e . This operation yields the equation

$$e = \frac{b}{2} \frac{1}{\frac{A_W}{6A_F} + 1} \quad (15)$$

This equation is the same as that attributed to Ostenfeld in reference 4 for locating the shear center.

The expression for torsion-bending factor for the channel, obtained by equations (10), (11), and (12), can be

simplified by substituting for e the value indicated in equation (15). This simplified expression for the torsion-bending factor for the channel is given in table II.

By substituting the dimensions of the channel section (fig. 1) into equation (15), a value for e of 0.36 inch is obtained.

REFERENCES

1. Timoshenko, S.: Strength of Materials. Pt. I. D. Van Nostrand Co., Inc., 1930, pp. 87 and 282.
2. Roark, Raymond J.: Formulas for Stress and Strain. McGraw-Hill Book Co., Inc., 1938.
3. Lyse, I., and Johnston, B. G.: Structural Beams in Torsion. A.S.C.E. Proc., vol. 61, no. 4, April 1935, pp. 469-508, discussion, pp. 509-516.
4. Seely, Fred B., Putnam, William J., and Schwalbe, William L.: The Torsional Effect of Transverse Bending Loads on Channel Beams. Eng. Exp. Sta., Bull. No. 211, Univ. Ill., July 1, 1930.
5. Wagner, Herbert: Torsion and Buckling of Open Sections. T. M. No. 807, NACA, 1936.
6. Wagner, H., and Pretschner, W.: Torsion and Buckling of Open Sections. T. M. No. 784, NACA, 1936.
7. Kappus, Robert: Twisting Failure of Centrally Loaded Open-Section Columns in the Elastic Range. T. M. No. 851, NACA, 1938.
8. Osgood, William R., and Holt, Marshall: The Column Strength of Two Extruded Aluminum-Alloy H-Sections. Rep. No. 656, NACA, 1939.
9. Goodier, J. N.: Torsional and Flexural Buckling of Bars of Thin-Walled Open Section under Compressive and Bending Loads. Jour. Appl. Mech., vol. 9, no. 3, Sept. 1942.
10. Timoshenko, S.: Theory of Elastic Stability. McGraw-Hill Book Co., Inc., 1936.
11. Lundquist, Eugene E., and Fligg, Claude M.: A Theory for Primary Failure of Straight Centrally Loaded Columns. Rep. No. 582, NACA, 1937.

TABLE I
 COMPARISON OF CALCULATED AND EXPERIMENTALLY DETERMINED VALUES
 OF ROTATION AND MAXIMUM LONGITUDINAL STRESS

Specimen	Torque at midspan (in.-lb)	Rotation at midspan (deg)			Maximum stress at midspan (lb/sq in.)		
		Measured	Calculated		Measured (3)	Calculated	
			Exact (1)	Approximate (2)		Exact (4)	Approximate (5)
I-beam	780	25.9	26.4	26.4	23,200	22,900	22,900
Channel	488	29.5	30.9	29.2	23,000	24,600	24,150
Z-bar	488	27.5	27.1	25.4	23,800	23,200	24,400

¹By equation (3) for $x = L/2$.

²By equation (7).

³Average for top and bottom flange.

⁴By equation (6) for $x = L/2$.

⁵By equation (9).

TABLE II
 EXPRESSIONS FOR TORSION-BENDING FACTOR AND
 UNIT WARPING FOR SECTIONS INVESTIGATED¹

Specimen	C_{BT}	u_1	u_2	u_3	u_H
I-beam	$\frac{I_F h^2}{2}$	0	0	$\pm \frac{hb}{4}$	—
Channel	$C_{BT} = \frac{I_F h^2}{2} \left(4 - 6 \frac{e}{b} \right)$	0	$\pm \frac{h}{2} e$	$\pm \frac{h}{2} (b - e)$	$\pm \frac{h}{2} \left(e + \frac{t_W}{2} \right)$
Z-bar	$C_{BT} = \frac{I_F h^2}{2} \left(4 - 6 \frac{A_F}{A} \right)$	$\pm \frac{hb}{2} \frac{A_F}{A}$	$\pm \frac{hb}{2} \frac{A_F}{A}$	$\pm \frac{hb}{2} \left(1 - \frac{A_F}{A} \right)$	$\pm \frac{h}{2} \left(\frac{A_F}{A} b + \frac{t_W}{2} \right)$

¹The area of one flange is designated $A_F = bt_F$; area of web, $A_W = ht_W$; area of cross section, $A = A_W + 2A_F$; moment of inertia of one flange, $I_F = b^3 t_F / 12$; and the other symbols are defined in fig. 14.

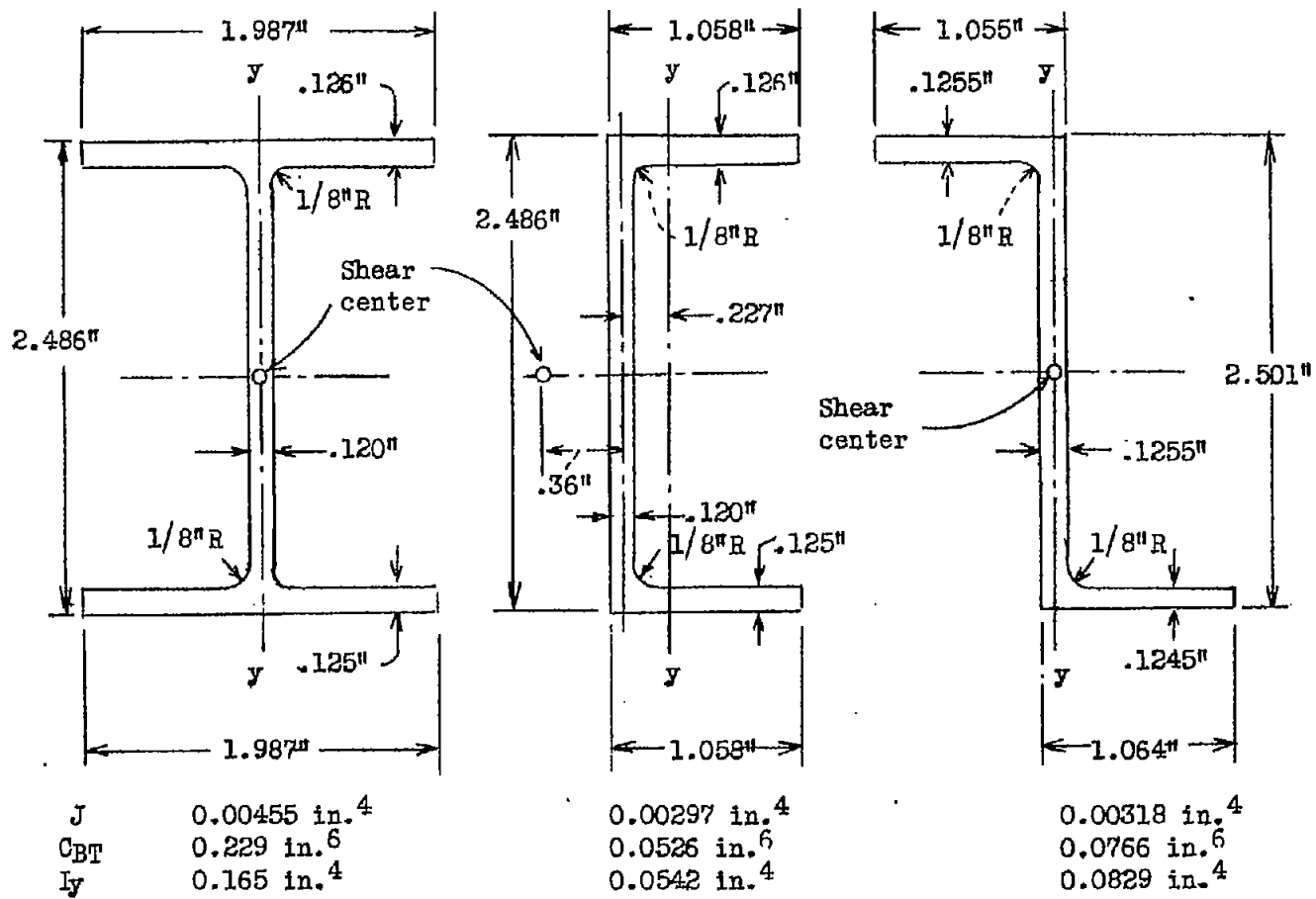

Figure 1.- Dimensions, as obtained by measurement, and section properties of specimens.

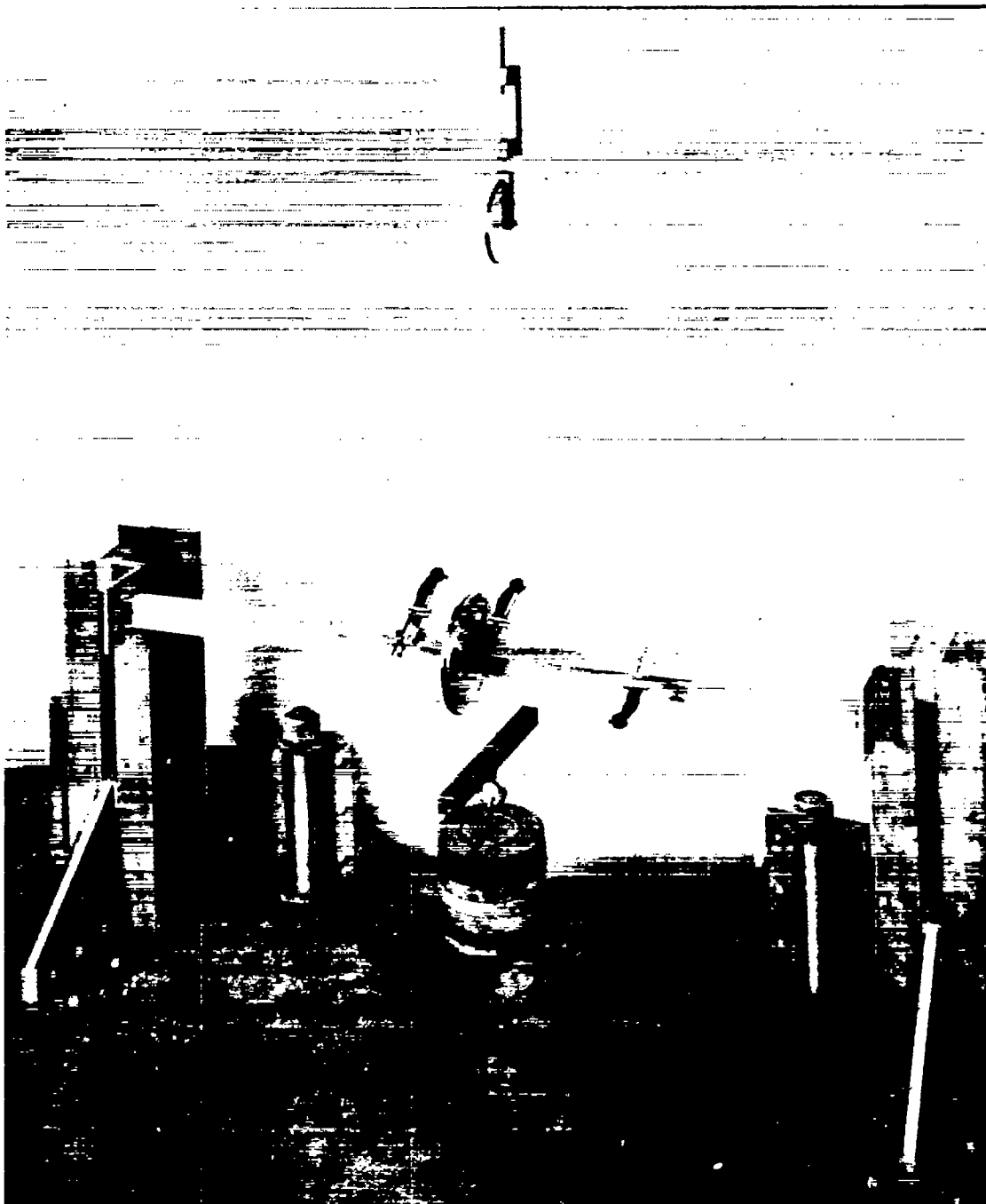

Figure 2.- General arrangement of test setup showing method of applying torque at midspan.

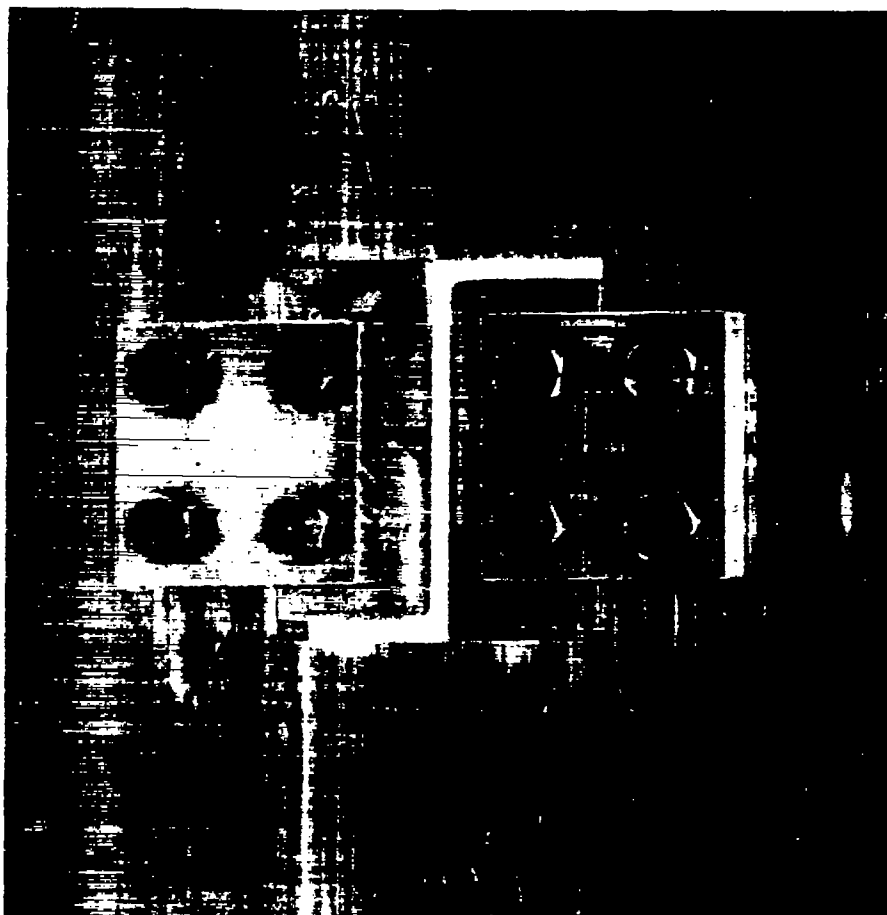
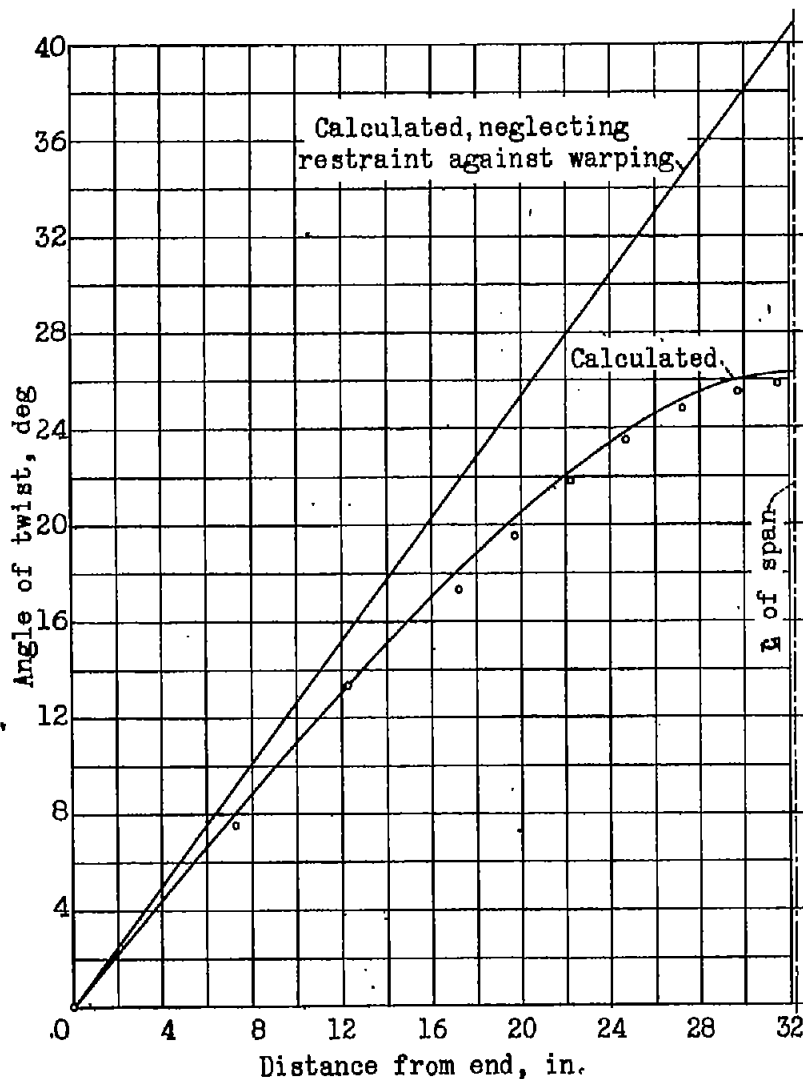
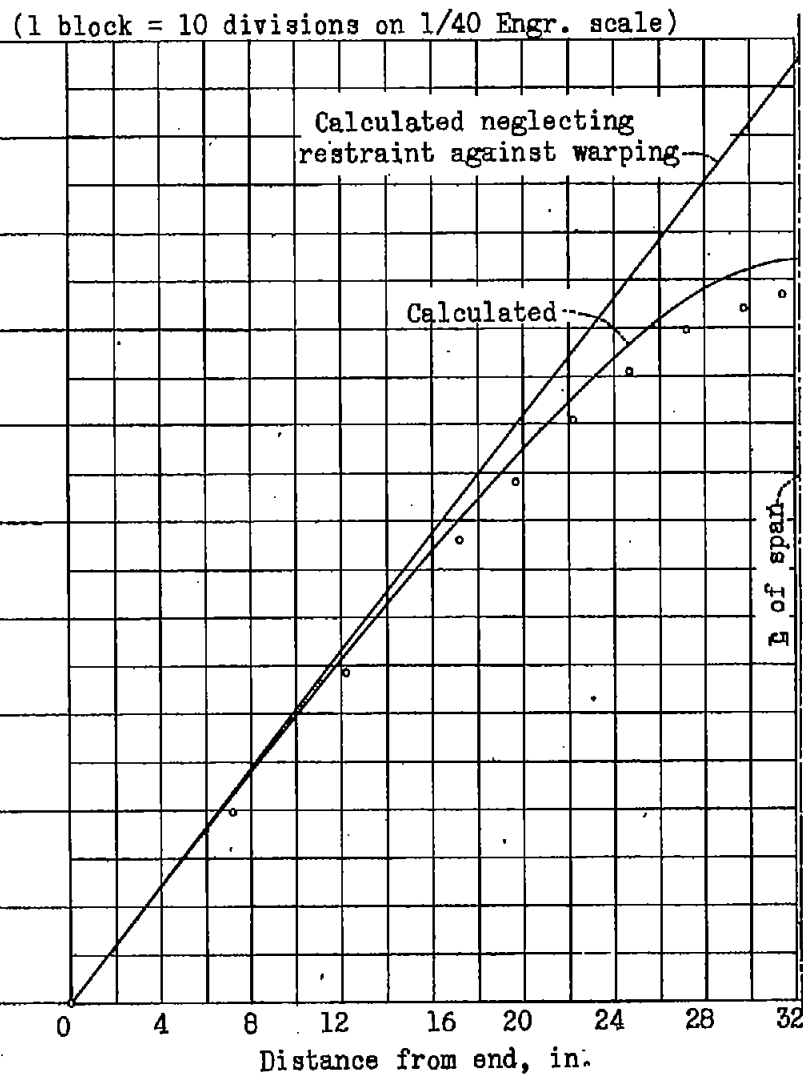

Figure 3.- Bracket for supporting end of specimen without restraint against warping, outside face.



Specimen, I-beam of X74S-T aluminum alloy;
 torque, 780 inch-pounds.

Figure 5.- Twist curves for torque applied at
 midspan. Span, 64 1/2 inches.



Specimen, channel of X74S-T aluminum alloy;
 torque, 488 inch-pounds.

Figure 6.- Twist curves for torque applied at
 midspan. Span, 64 1/2 inches.

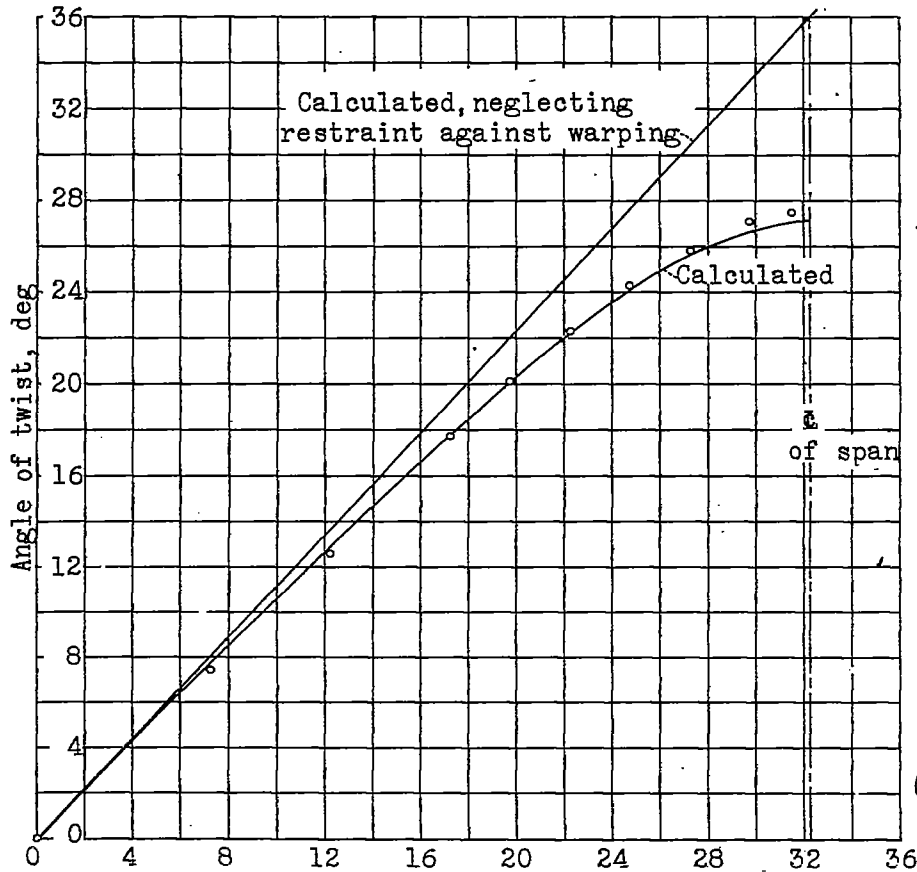
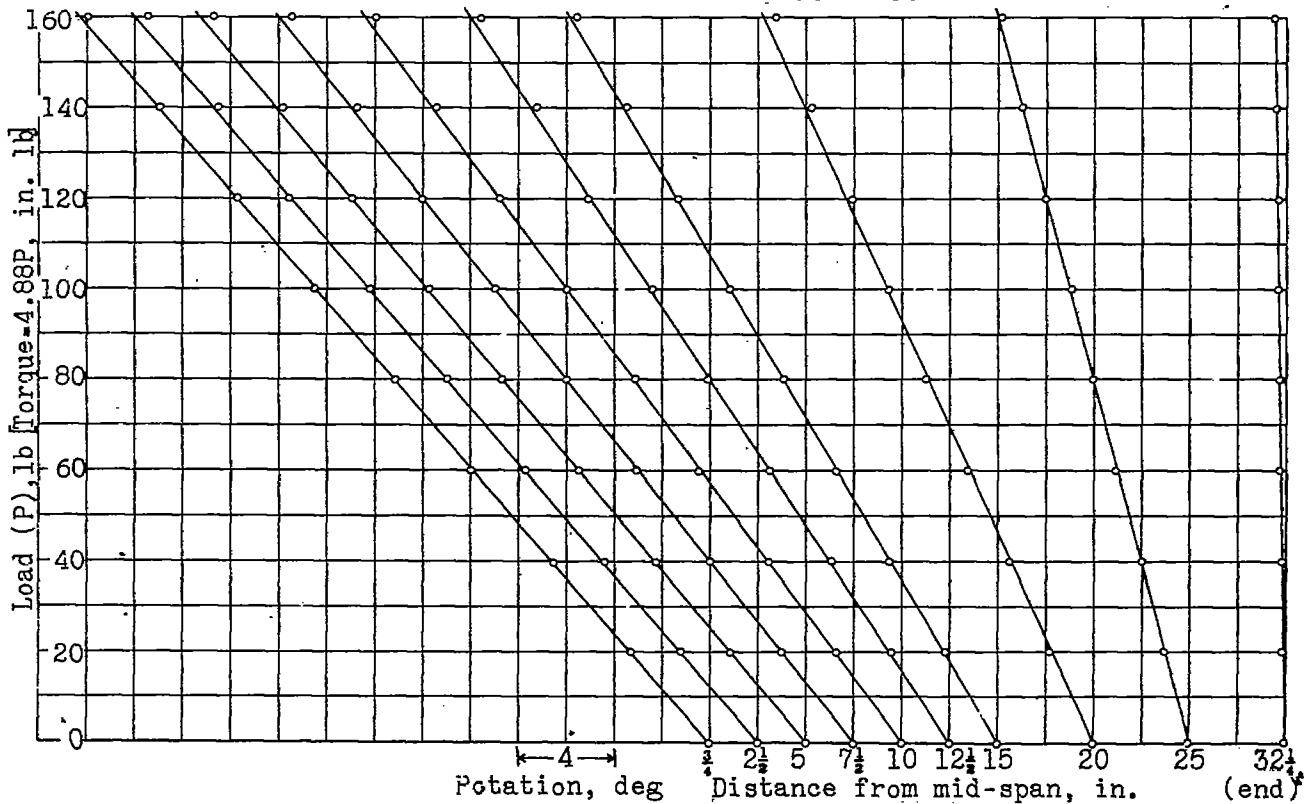

Figure 7.- Specimen, Z-bar of 24S-T aluminum alloy; torque, 488 inch-pounds. Twist curves for torque applied at midspan. Span 64 1/2 inches.

Figure 8.- Specimen, I-beam of X74S-T aluminum alloy. Load-rotation curves for torque of 4.88P inch-pounds.

(1 block = 10/40")



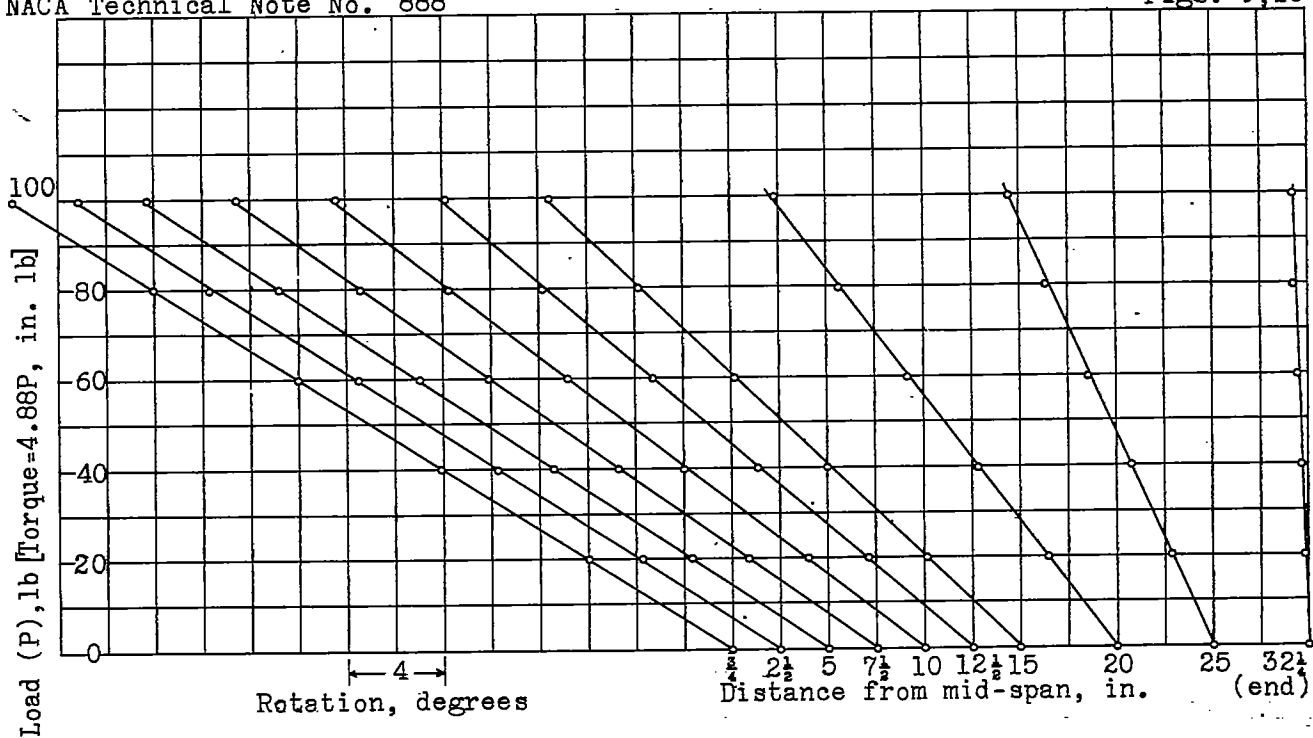

Figure 9.- Specimen, channel of X74S-T aluminum alloy.
 Load-rotation curves for torque of 4.88P inch-pounds.

(1 block = 10/40")

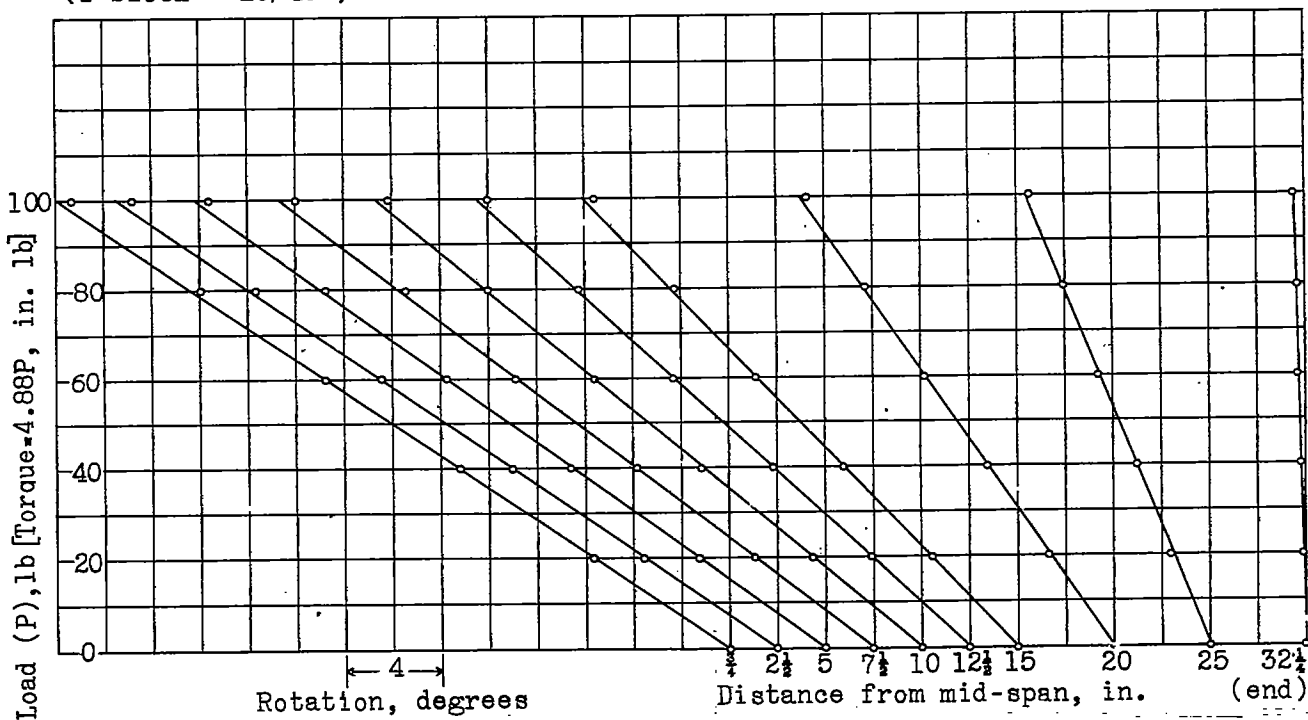
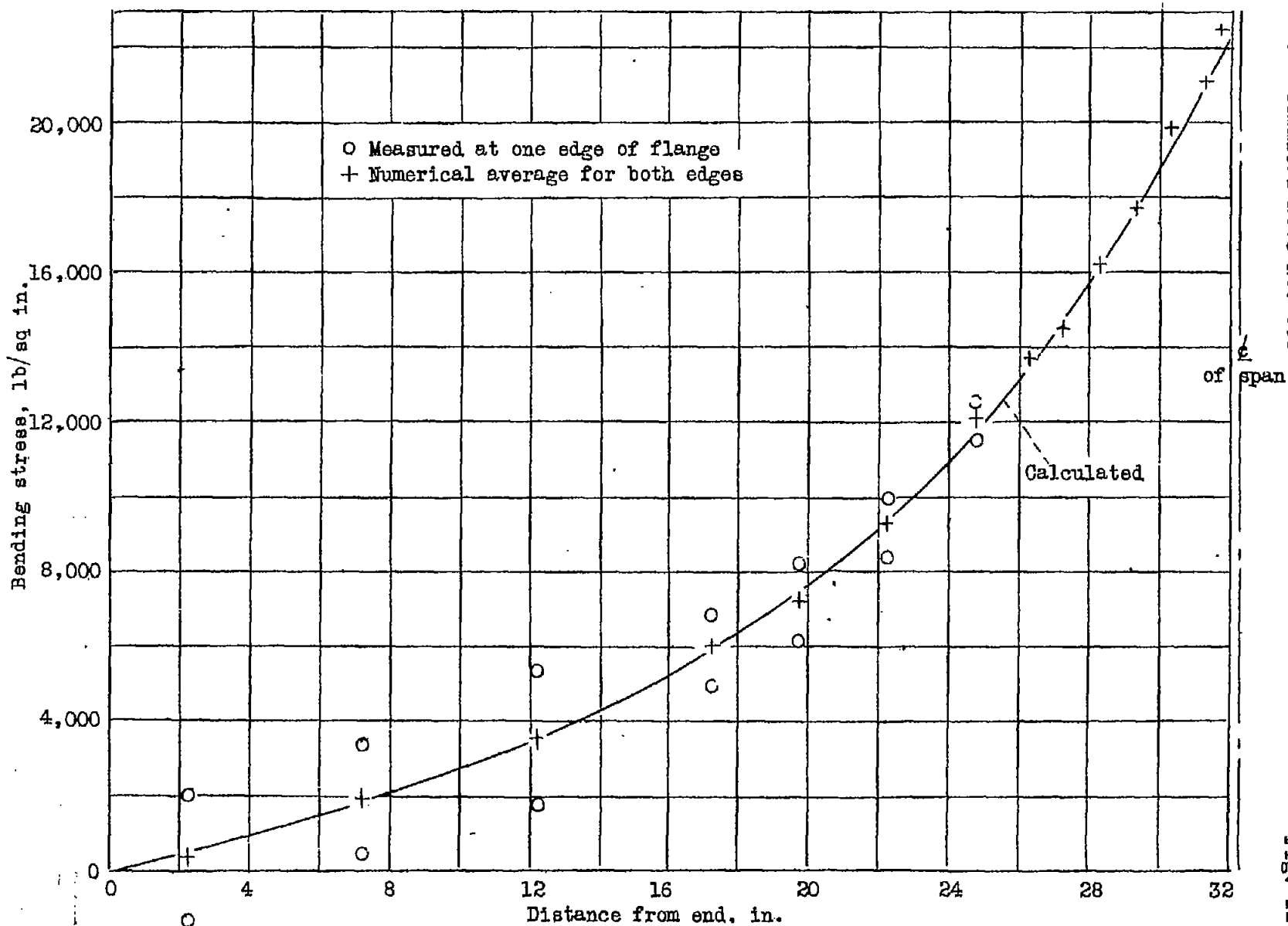

Figure 10.- Specimen, Z-bar of 24S-T aluminum alloy.
 Load-rotation curves for torque of 4.88P inch-pounds.



NACA Technical Note No. 888

Fig. 11

Figure 11.- Bending stresses in flanges of I-beam of X74S-T aluminum alloy under a torque of 780 inch-pounds applied at midspan.

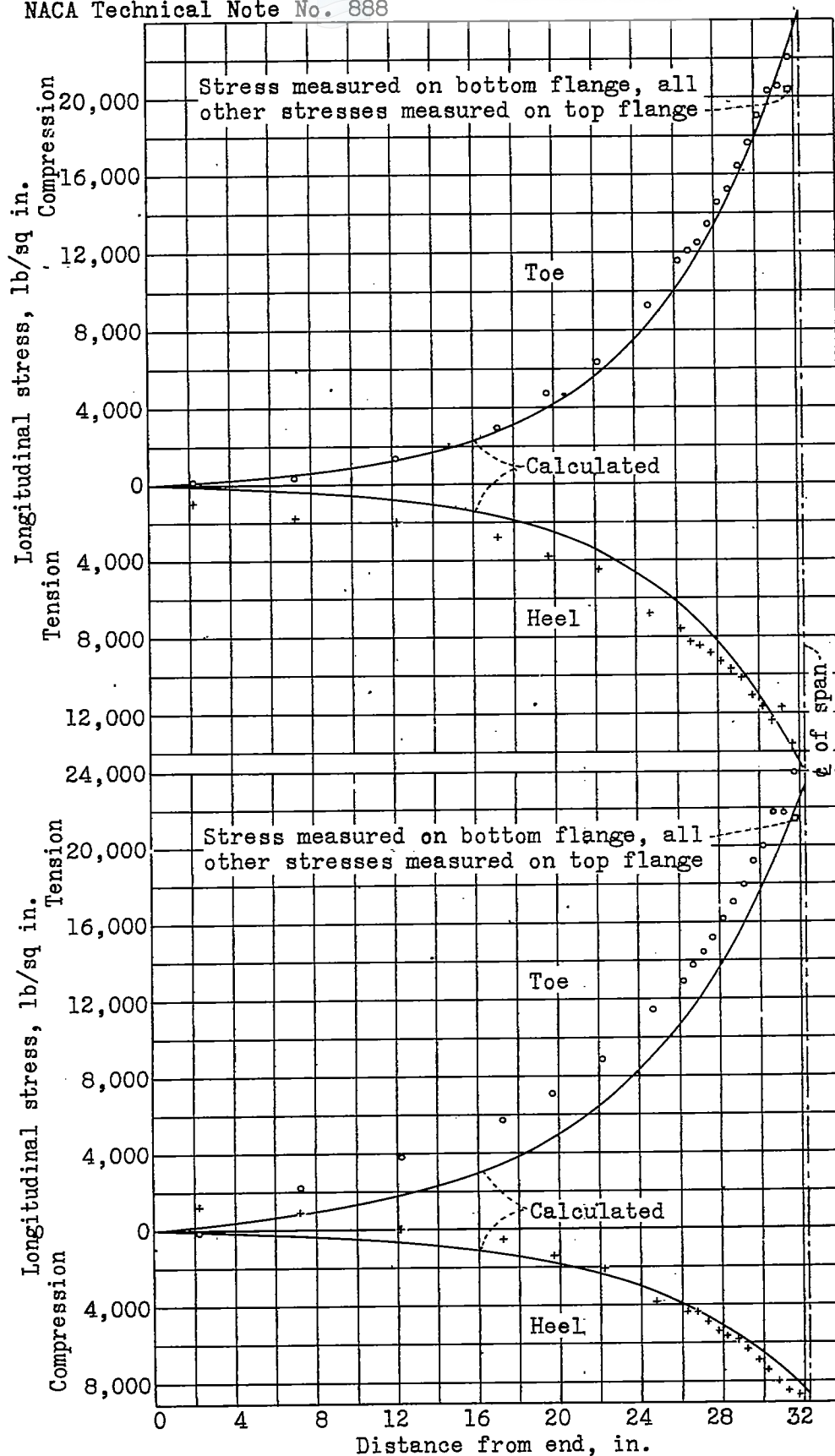
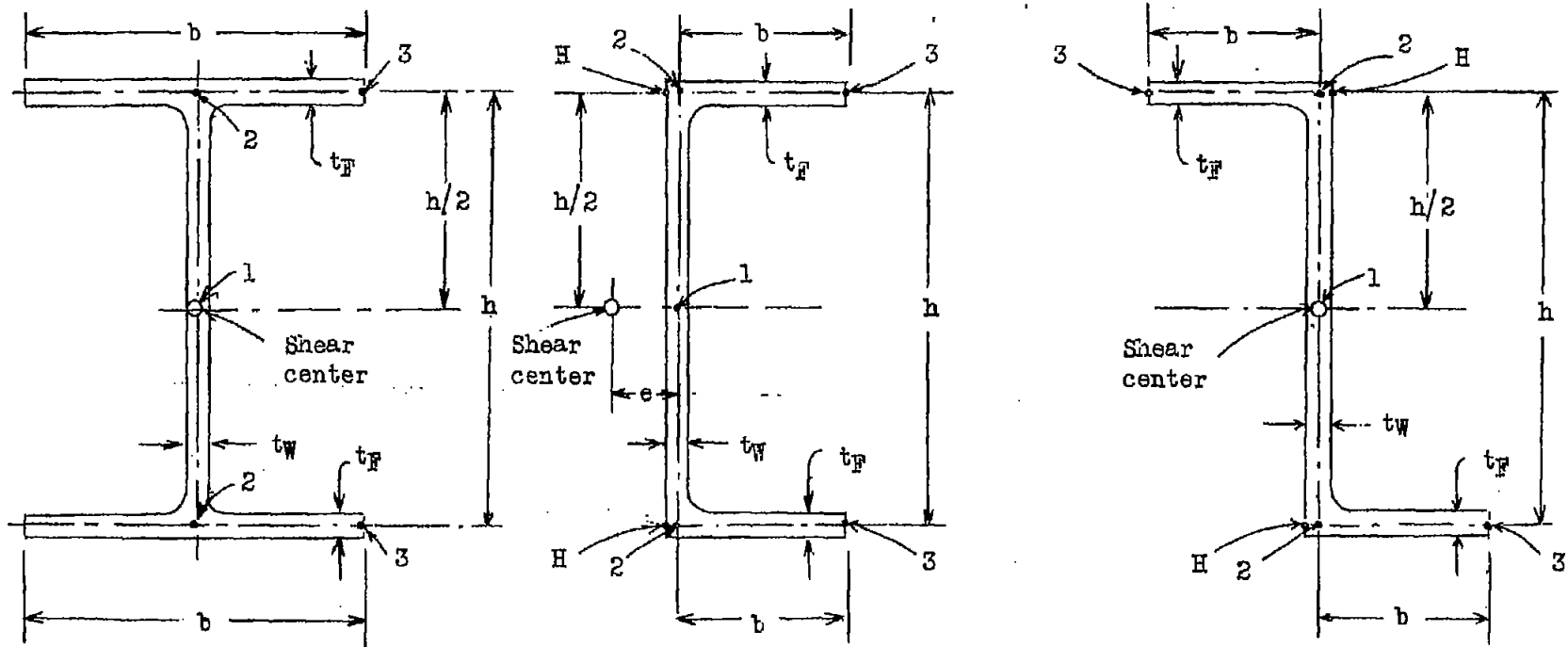

Figure 12.-
 Specimen,
 channel of
 X74S-T
 aluminum
 alloy.
 Longitudinal
 stresses
 in specimens
 under
 torque of
 488 inch-
 pounds
 applied
 at midspan.

(1 block = 10/40")

Figure 13.-
 Specimen,
 Z-bar of
 24S-T
 aluminum
 alloy.
 Longitudinal
 stresses
 in specimens
 under
 torque of
 488 inch-
 pounds
 applied
 at midspan.



MACA Technical Note No. 888

Fig. 14

Figure 14.- Dimensional notation used in the expressions given in table II for the torsion-bending constant C_{BT} and for the unit warping u .