

APR 12 1946

NATIONAL ADVISORY COMMITTEE FOR AERONAUTICS

TECHNICAL NOTE

No. 990

MEASUREMENT OF THE ARITHMETIC MEAN VELOCITY OF A
PULSATING FLOW OF HIGH VELOCITY BY THE HOT-WIRE METHOD

By John R. Weske
Case School of Applied Science

FOR REFERENCE

NOT TO BE TAKEN FROM THIS ROOM



Washington
April 1946

NACA LIBRARY
LANGLEY MEMORIAL AERONAUTICAL
LABORATORY

Langley Field, Va.

NATIONAL ADVISORY COMMITTEE FOR AERONAUTICS

TECHNICAL NOTE NO. 990

MEASUREMENT OF THE ARITHMETIC MEAN VELOCITY OF A
PULSATING FLOW OF HIGH VELOCITY BY THE HOT-WIRE METHOD

By John R. Weske

SUMMARY

The report deals with an experimental method of measuring both the arithmetic mean velocity and the instantaneous velocity of pulsating flow and with the instruments developed for this purpose.

A circuit for a hot-wire anemometer applicable to the measurement of fluctuating flow is described. The principal elements of the circuit are a Wheatstone bridge, one arm of which is the hot wire, and an electronic amplifier and a current regulator for the bridge current which in combination maintain the bridge balanced. Hence the hot wire is kept at practically constant resistance and temperature, and the time lag caused by thermal inertia of the wire is thereby reduced.

Through the addition of a nonlinear amplifier stage the reading of the instrument has been rendered proportional to the velocity.

A discussion of static and dynamic response of the circuit and of directional characteristics of the hot wire is given. Calculated characteristics are related to the results of calibration tests.

Hot-wire measurements of mean velocity and of the velocity profile of instantaneous velocities were obtained at the outlet of a rotating axial flow blade grid and correlated with measurements obtained with a pitot tube.

INTRODUCTION

Frequently it is necessary to determine the mean velocity in a stream of fluctuating velocity. If the direction of flow remains constant, the mean velocity may be determined from pitot tube measurements, provided the magnitude and character of the deviations from mean velocity are known. If, however, both the velocity and the direction of flow vary over a considerable range, for example, at the outlet of blade rows or compressor impellers, conventional methods of aerodynamic measurement fail to give accurate results.

It was for the purpose of developing a satisfactory method of measurement in instances similar to that cited that a program of investigation of the hot-wire technique was undertaken at Case School of Applied Science. This work was carried out under the auspices of the National Advisory Committee for Aeronautics, which also provided funds. Of necessity the measurement of instantaneous velocity profiles has been included in the program. Because of repeated delay in the delivery of testing equipment it was not possible to extend the investigation to velocities of the order of sound velocities, as intended. Instead the analysis of the instrument characteristics has been developed in detail, which should simplify further work in the high-velocity region.

The laboratory work and the calculation were carried out by Mr. R. J. Carleton and Mrs. F. Scott Rodgers, research assistants at Case School of Applied Science.

THE HOT-WIRE INSTRUMENT

The Component Parts

The hot-wire instrument consists of the following component elements shown schematically in figure 1:

- (a) A Wheatstone bridge, one branch of which is formed by the hot wire
- (b) A regulating circuit for the bridge current, including a battery or power supply and an electronic valve
- (c) An electronic direct-current amplifier operated by slight variations of the unbalance of the bridge and controlling the current regulator

In addition to the above-mentioned three components which constitute the basic circuit, an additional element also shown in figure 1 may be provided; namely,

- (d) A nonlinear amplifier stage; this stage is required only if instrument characteristics other than those resulting from the heat transfer characteristics of the hot wire are desired and makes it possible, in combination with the basic circuit, to obtain readings proportional to the wind velocity past the hot wire.

Principle of Operation

If certain dynamic effects discussed later are neglected, the operation of the basic circuit can be explained as follows: The circuit is assumed to be operating at a given condition of equilibrium. Then a disturbance, such as may be produced by a change of velocity past the hot wire occurs, causing a variation of resistance of the hot wire and consequently a variation of potential between points (2) and (4) of the bridge (fig. 1). This electric impulse is transmitted and amplified by the amplifier stages. A variation of the potential between grid and cathode of the current-regulating tubes and a corresponding variation of the hot wire current is the result. The resistance of the hot wire is thereby varied in such a way as to counteract the original disturbance, and a new condition of equilibrium is established. By proper choice of the amplification ratio of the amplifier it is possible, within certain limits imposed by tube characteristics and stability of the circuit, to make the difference between the hot-wire resistance of the original and the new position of equilibrium very small. The hot wire consequently operates essentially at constant resistance—that is, at constant temperature.

In addition to the reduction of fluctuation of hot-wire resistance, there is a corresponding reduction of the time lag of response to variation of the condition of operation, provided the effect of capacitances in the circuit is also kept small. This provision is necessary because the magnitude of the time lag depends both upon the residual thermal inertia of the wire and upon the effect of such capacitances.

Hot wire readings with the basic circuit are obtained by measuring directly the heating current or by measuring a quantity proportional to it, such as the grid voltage of the current-regulator tubes, with respect to the ground.

In order to obtain a reading linear with velocity, use is made of an additional amplifier stage, item d of the preceding section, operated in a range of its characteristics, in which the exponent of the variation of plate current with grid potential, expressed in exponential form, is equal to the reciprocal of the exponent relating variations of heating current and of velocity past the hot wire. Tubes, such as those listed in tables I and II, were found to have a suitable range in which stable operation may be obtained. When adjusted for linearity between reading and velocity, the circuit may be expected to measure the mean velocity of fluctuating rectilinear flow.

The Circuit

(a) Features of design of the hot-wire circuit.- Circuit diagrams and circuit constants of the hot-wire instrument are given for two versions of the instrument: namely,

(a) For battery operation, figure 2 and table I

(b) For operation from 110-V alternating-current supply, figure 3 and table II

The two circuits are alike except for deviations necessitated by the different forms of power supply.

The bridge was designed with a view to keeping the input impedance of the amplifier low and to obtain a temperature adjustment which would stay constant over a sufficiently long period. The adjustable air condenser was provided to effect close balance of the bridge for alternating current, and a second condenser in the grid-leak circuit of the amplifier to compensate for the effect of interelectrode capacitance in the amplifier.

The design of the nonlinear stage was governed by the desirability of having one terminal of the output (i.e., the ground connection of the cathode-ray oscilloscope) at ground potential.

From operating experience with both versions of the hot-wire instrument it was concluded that the battery-operated instrument as designed has a lower time lag than the alternating-current supplied instrument.

It was found, however, to require frequent adjustment of bridge balance to counteract voltage drop of the batteries. Short effect, which is of negligible magnitude with fresh batteries, increases rapidly with age of the batteries to an

order of magnitude equal to that of the signal. With the alternating-current-supplied instrument it was possible to maintain bridge adjustment indefinitely once all tubes had reached their equilibrium temperature; however, it has a higher time lag and an alternating-current hum which precluded the investigation of the high-frequency fluctuation of small amplitude.

(b) Design of power packs.— The power packs (fig. 4) were designed to meet the following requirements:

- (a) Maximum insensitivity of output voltage to variations of input voltage
- (b) Minimum alternating-current ripple
- (c) Minimum time lag of response to variations of load

These requirements were established after an investigation of the effect of power pack characteristics upon operation of the hot-wire instrument. They were found to be more exacting than those ordinarily applied to power-pack characteristics and therefore necessitated the development of special circuits.

The basic design of all three power-pack circuits is identical. Each power-pack consists of the following elements:

Main auxiliary transformers

Rectifier tube

Filter

Constant-current device, consisting of an electronic tube and associated elements, such as a voltage regulator tube for the screen circuit

Voltage-regulator-tube circuit parallel to the output

Difference of output capacity and of the location of ground connection resulted in certain differences in the design of the circuit, among them the following. The current-regulator-supply power pack has four voltage-regulator tubes in parallel capable of supplying a total of 100 milliamperes output. The resistors placed in series with these tubes insure firing of all tubes as the power pack is energized and approximate equality of current through each at any load condition. A separate screen supply for the current-regulator tube was provided, the voltage of which is independent of the output within closer limits than that of the plate supply of the current regulator.

The circuit of the power pack for the screen and plate supply of the direct-current amplifier differs from that for the grid leak, apart from differences of the values of certain circuit constants, by a condenser C_7 (fig. 4). This condenser serves to eliminate a ripple, and also decreases the time lag of response to variation of output.

The relay in the current regulator supply was found necessary to protect the screen leak VR tube during the warming-up period of the power packs. Dynamic response of the power packs constant current to variation of load was tested by connecting valve, a current amplifier circuit controlled by a square wave generator to the output and measuring the time lag. In all cases the time constant (see sec. on Response to Fluctuations of Velocity) was found to be less than 1×10^{-6} second.

ANALYSIS OF OPERATING CHARACTERISTICS

List of Symbols

- | | |
|-----------------|--|
| A | tube in hot-wire circuit for battery-operated hot-wire instrument |
| B | filament switch in circuit for battery-operated hot-wire instrument |
| C | equivalent capacitance in circuit for battery-operated hot-wire instrument |
| C_D | drag coefficient |
| c | constant in King's equation (2) |
| c_p | specific heat |
| D_1 | milliammeter in circuit for battery-operated hot-wire instrument |
| D_2 | microammeter in circuit for battery-operated hot-wire instrument |
| d | diameter of wire |
| E | steady flow voltage |
| e | instantaneous voltage |
| f_1, f_2, f_3 | non-dimensional ratios of heating current to velocity |
| G | galvanometer in hot-wire circuit |

- g'_m over-all transconductance of circuit
- $(g'_m)_{cr}$ transconductance of current regulator value
- H quantity of heat
- i instantaneous heating current
- i_0 heating current at zero air velocity
- $j = \sqrt{-1}$
- $K = \frac{\Delta\Omega/\Omega}{\Delta l/l}$ strain sensitivity of wire
- k constant in King's equation (2)
- l length of wire
- M time constant, sec
- m mass of hot wire
- $n = \frac{\omega}{2\pi}$ frequency
- R instantaneous resistance of hot wire
- \bar{R} mean ohmic resistance of hot wire
- R_a resistance of hot wire at temperature of ambient air
- R_0 resistance of heated wire at zero velocity
- S power supply terminal
- s maximum sag of wire
- T temperature of wire
- T_0 air temperature
- t time
- V velocity, ft/sec
- Z impedance of hot wire
- α temperature coefficient of resistivity
- σ tensile stress
- θ angle of incidence
- ϕ, ϕ_1, ϕ_2 over-all phase lag of simple harmonic signal, of hot wire, and of amplifier, respectively

- μ' amplifier gain
- ρ mass density, lb sec²/ft⁴
- ω angular velocity
- Ω resistance, ohms
- Subscript
- cr current regulator value

Strength of Hot Wires at High Velocities

In testing hot wires of platinum in air streams of high velocity the observation was made that new wires, which were soft-soldered taut between their supporting prongs acquired a slight sag from exposure to a stream of 200 and even 150 feet per second velocity. As this could not be ascribed to failure of the solder joints, it was inferred that the wire was stretched. Further increase in velocity would increase sag until whipping of the wire occurred, which then would lead to breakage. Platinum wire of a length-diameter ratio $l/d = 1000$ would fail consistently at velocities exceeding 300 feet per second. No stretching of tungsten wire was observed after exposure to velocities from 500 to 800 feet per second.

(a) Equation for strength characteristics of hot wires.

In order to establish a general relationship for the strength characteristic of the hot wires, it is assumed that breakage of the wire occurs as the aerodynamic drag causes the tensile stress in the wire to exceed the safe maximum limit for the metal. Let it be assumed further that the curves of the wire under load are similar - that is, that the ratio of sag p , to length l , is constant. The following relation may be established by the approximation of the curve by a parabola:

$$C_D \frac{\rho V^2}{2} l d \frac{l}{8p} = \sigma \frac{\pi d^2}{4}$$

hence

$$\sigma = \frac{1}{3\pi} C_D \frac{\rho V^2}{2} \left| \frac{l}{d} \right| \frac{l}{p} \quad (1)$$

(b) Maximum permissible length of hot wire.- Equation (1) may be used to calculate the maximum permissible length of a hot wire. To this end the following values have been assumed:

1. Reynolds numbers for hot wires cover the range from 10 to 50.
2. Corresponding drag coefficients are from 3.0 to 1.2.

3. Calculations were carried out for $C_D = 1.0$; if desired, results may readily be corrected for any given value of C_D .
4. In the absence of specific information it was assumed that a sag equal to $1/100$ of the length of the wire constitutes an acceptable operating condition, and calculations have been carried out for this value, $l/p = 100$.

The limiting velocity for safe operation of the hot wire in respect to breakage was defined as the velocity of an air stream of standard sea-level density producing a tensile stress in the wire equal to the yield stress of the material. The tensile strength of fine wires varies a great deal as a result of the drawing process and the subsequent annealing of the wires for purposes of aging before its use. The figures given in the following table are believed to represent average values.

TENSILE STRESS AND STRAIN PROPERTIES OF HOT WIRES

Material	Ultimate tensile strength (psi)	Yield strength (psi)	Modulus of elasticity (psi)
Platinum	20,000 to 30,000 annealed 53,000 hard drawn	as low as 5000 annealed	24.2×10^6 drawn
Tungsten	215,000 swaged rod 0.3 inch diameter 590,000 hard drawn wire 0.00114 inch diameter	500,000 hard drawn wire 0.00114 inch diameter	51.4×10^6 drawn wire

On the basis of the data of this table, curves have been plotted in figure 5 giving maximum operating velocities versus length-diameter ratio for various yield stresses. These data lead to the conclusion that platinum wire may be used at relatively low velocities; whereas tungsten wire is applicable for very high air velocities.

(c) Strain sensitivity. - It is known that the electric resistance of metal wires increases as the wire is subjected to strain. The strain sensitivity is defined as the ratio:

$$\frac{\text{Unit resistance change}}{\text{Unit strain change}} = \frac{\Delta\Omega/\Omega}{\Delta l/l} = K$$

(See reference 3.) This strain sensitivity forms the basis of strain measurements by means of wire strain gages. In reference 3 the values are given for the above ratio for strain gage wire; namely,

K = 2.15 for cupronickel wire

K = 3.6 for isoelastic wire

Since corresponding values for tungsten wire were not discovered in the literature, a simple test was made for the purpose of identifying strain sensitivity and of establishing its order of magnitude for this material.

A tungsten wire of 0.0011 centimeter diameter was subjected to tensile loads. At the same time a constant current of 20 milliamperes was passed through the wire and the voltage drop was measured. The temperature of the wire was but slightly in excess of room temperature. No tests were conducted at normal operating temperatures of hot wires. The tungsten wire was subjected to tensile stress of from 200,000 to 400,000 pounds per square inch. The strain sensitivity was calculated to be K = 1.7.

The calculated percentage variation of tungsten wire for an assumed change of tensile stress of 200,000 pounds per square inch, based on the measured strain sensitivity is 0.57 percent.

Strain sensitivity will affect the heating current of a hot wire exposed to a high velocity air stream. From King's equation (see sec. on Static Response Characteristics of Hot Wires at Constant-Resistance Operation) it is seen that an increase of the tension in the hot wire due to the impact of the air causes an increase of its resistance R and for a self-balancing bridge circuit a corresponding decrease of the heating current. This deviation from King's equation is shown schematically in a graph of the square of the heating current versus the square root of velocity (fig. 6). This effect may be as high as 1 milliampere and appears to make itself felt in calibration curves. (See fig. 12, curve C). The effect of strain sensitivity may be minimized by reducing the length-diameter ratio of the hot wire. Use may be made of the graph (fig. 5) in conjunction with the data of the pre-

ceding table on Tensile Stress and Strain Properties of Hot Wires in selecting a satisfactory length-diameter ratio.

(d) Method of mounting tungsten wire.— Hot wires of platinum and nickel were mounted on their supporting prongs by soft-soldering. This resulted in a connection which from calibration tests appeared to be satisfactory both in regard to mechanical strength of the connection and in regard to its electrical resistance within the range of velocities for which these wires are applicable. The ranges of velocities are limited by the tensile strength of the hot wire itself.

Considerably more difficulty was encountered in attempting to mount hot wires of tungsten. Two methods of mounting tungsten wire were investigated; namely, the spot-welding method, and a special method described hereafter permitting soft-soldering of the hot wire.

The welding of tungsten wire was done by a very simple welding device in which the current and the fusion time could be controlled only very crudely. As a consequence, the prongs or the tungsten wire would burn and the probability of obtaining two satisfactory welds and a taut wire was low. It is believed, however, that neat welds could be obtained with a welding device allowing careful control of the conditions. However, since such a unit was not available, this possibility was not pursued further.

A second method of mounting tungsten wire was developed as a result of extended experimental investigation, in the course of which more than fifty wires were mounted and subsequently tested in an airstream of up to 600 foot-per-second velocity. It was recognized that a hot-wire connection, to be satisfactory for use in high-velocity air streams, must have two discrete properties; namely, it must have adequate strength and its electrical resistance preferably should be negligible compared with the resistance of the hot wire, or alternatively, it should be low and constant.

When attempting to soft-solder tungsten wire it was found that soft-solder does not readily adhere to tungsten. This condition appeared to be aggravated for certain samples of tungsten wire which were believed to have acquired a coat of tungsten oxide.

A method of obtaining a satisfactory connection between tungsten wire and its prongs which takes account of the foregoing considerations is described with reference to figure 7

by enumerating the various steps of the technique of mounting a tungsten wire of 0.00061 centimeter diameter:

1. Pickling of the tungsten wire in hot aqua regia solution to remove the tungsten oxide. Duration of the process, 1/2 to 2 hours.

2. Plating of the wire in an electrolytic bath of rhodium. A voltage of $1\frac{1}{2}$ volts was applied to the electrodes for 30 seconds (figs. 7a and 7b).

3. Mounting of the tungsten wire between u-shape copper wire shown in figure 7c. The u-shape wire is to be twisted several times to wind the tungsten wire around the copper wire after insertion of the latter into the hollow prongs. Proper tension of the tungsten wire may be established conveniently by this method. The tungsten wire is then pushed into a notch at the rim of the supporting prongs.

4. Soft-soldering of the u-shape wire and the tungsten wire into the prong.

5. Removing of the rhodium from the hot wire outside the solder joint by immersion into an aqua regia solution. It is found that the solder is attacked much more slowly by the acid than the rhodium, and no harm is done to the solder connection.

6. Microscopic inspection of the solder joint and of the hot wire.

Tungsten wires mounted by this method were found to be suitable for measurements in high velocity streams both in regard to strength of the mounting and in regard to its electrical resistance. The photograph of a hot-wire holder (fig. 8) shows the proportions for a wire of 0.5 centimeter length.

Static Response Characteristics of Hot Wires at Constant-Resistance Operation

If constant resistance of the hot wire, or zero rate of increase of heat energy in the wire, $dH/dt = 0$, is assumed, the balance of energies supplied to, and dissipated by, the hot wire may be expressed by King's equation (references 1 and 2).

$$3.4 \cdot i^2 = \frac{T-T_0}{R} (k+c\sqrt{V}) \quad (2)$$

Of interest is the variation of heating current with velocity at constant hot wire and ambient air temperature, $T-T_0 = \text{constant}$, in which case it may be assumed that both k and c also remain constant.

The variation of heating current with unit variation of velocity may then be calculated from equation (1), using new constants $k' = \frac{T-T_0}{3.4R} k$ and $c' = \frac{T-T_0}{3.4R} c$

$$f_1 = \frac{di}{dV} = \frac{1}{4V} \frac{c'\sqrt{V}}{\sqrt{k'+c'\sqrt{V}}} \quad (3)$$

The variation of heating current for 1-percent variation of velocity is

$$f_2 = \frac{1}{100} \frac{di}{dV} = \frac{1}{400} \frac{c'\sqrt{V}}{\sqrt{k'+c'\sqrt{V}}} \quad (4)$$

Finally, the percentage of variation of heating current for 1-percent variation of velocity is

$$f_3 = \frac{\frac{(di)}{i}}{\frac{(dV)}{V}} = \frac{1}{4} \frac{c\sqrt{V}}{k+c\sqrt{V}} \quad (5)$$

The functional relations according to equations (3) to (5) have been plotted in figure 9 for $k = 10$ and $c = 1$. It follows that the accuracy of hot-wire readings, contrary to general belief, at high velocities is inherently superior to that at low velocities, at least for constant-resistance operation considered here.

Response to Fluctuations of Velocity

Lag of response of the circuit to variations of velocity may be caused by (1) lag of response of the hot wire, resulting in lag of the input signal of the amplifier and (2) by lag

of the amplifier and current regulator tube, resulting in lag of the heating current with respect to the input signal of the amplifier.

The time lag may be expressed by the angle of phase lag of a simple harmonic signal. Let the angle of phase lag of the hot wire be φ_1 , and of the amplifier φ_2 . Then the over-all phase lag is

$$\varphi = \varphi_1 + \varphi_2$$

(a) Phase lag of the hot wire.— Considering first the response of the hot wire it is recalled that the resistance of the hot wire does not remain precisely constant. Its variations are related to variations of heating current by the equation

$$i = i_0 [1 - g'_m (R - R_a)] \quad (6)$$

Proportional changes of the temperature and the heat content of the hot wire take place. The latter induces a heat-transfer process requiring time, which is the cause of the time-lag of response. This time lag has been expressed by Dryden and Kuethé for constant-resistance operation (reference 2) in the following form

$$M = \frac{4.2 m c_p (\bar{R} - R_a)}{i^2 R_a R_o \alpha} \frac{1}{1 + g'_m \frac{(\bar{R} - R_a) \bar{R}}{R_a}} \quad (7)$$

For values of the transconductance obtainable with the basic circuit

$$2 g'_m \frac{(\bar{R} - R_a) \bar{R}}{R_a} \gg 1 \quad (8)$$

hence equation (7) may be simplified to read

$$M = \frac{4.2 m c_p}{2 i^2 g'_m \bar{R} R_o \alpha} \quad (9)$$

The phase lag, φ_1 , of the hot-wire response to a simple harmonic variation of frequency $n = \frac{\omega}{2\pi}$ may then be calculated

$$\varphi_1 = \tan^{-1}(-M 2 \pi n) = \tan^{-1}(-M \omega) \quad (10)$$

When expressing the time constant in terms of the ohmic resistance \bar{R} and the equivalent capacitance C of the hot wire, $M = \bar{R}C$ (fig. 10),

$$\varphi_1 = \tan^{-1}(-\bar{R}\omega C) \quad (11)$$

The minus sign in equations (10) and (11) indicates that the current lags.

It is seen from equation (9) that the time lag of the hot wire decreases as the over-all transconductance of the circuit increases.

(b) Phase lag of the amplifier.— The amplifier stages are resistance-coupled, and the only source of phase lag therefore is the interelectrode capacitances of the amplifier tubes. As their effect may be reduced to a negligible amount by a small compensating condenser shown in figures 2 and 3, the amplifier operates at practically zero phase lag in the range of frequencies encountered.

(c) Dynamic characteristics of circuit response.— In conjunction with the design of the hot-wire circuit, calculations of the response to velocity fluctuations were made and the results are shown in figure 11, in the form of curves of angle of phase lag versus amplifier gain μ' for simple harmonic variations of hot wire resistance of various frequencies. In these calculations the transconductance of the current-regulator valve was assumed to have the constant value $(g'_m)_{cr} = 0.005$. The phase lag of the amplifier was assumed to be zero.

The calculations were carried through for two different hot wires for which data is given in the following table:

Type of wire	Platinum wire	Tungsten wire
Diameter $d =$	0.00025 centimeter	0.00061 centimeter
length $l =$	0.635 centimeter	0.635 centimeter
$l/d =$	2,540	1,040
Current at zero velocity $i_0 =$	10×10^{-3} ampere	20×10^{-3} ampere
Time lag at $g'_m = 50$	$M = 0.0238 \times 10^{-6}$ second	$M = 11.35 \times 10^{-6}$ second

The following conclusions may be derived from inspection of figure 11.

1. The residual thermal inertia of the hot wire is the principal factor in determining hot-wire response. For maximum response to fluctuations of velocity of high frequency it is desirable to use as thin a hot wire as can be handled.

2. For a given hot wire there exists an optimum gain of the amplifier in regard to phase lag and tube noise. Amplifier gain and hot-wire characteristics should be matched for best response of the circuit. (See sec. d.)

3. Development of the hot-wire circuit for response to high-frequency oscillations call for high amplifier gain and for compensation of the phase lag of the amplifier, which may easily be accomplished over a wide band of frequencies by conventional technique.

(d) Limits of response.— Increase of over-all transconductance decreases the time lag according to equation (9). It likewise decreases the variation of hot-wire resistance ($R - R_0$) for a given velocity variation according to equations (6) and (2) and thereby the magnitude of the input signal of the amplifier, which varies inversely to the amplifier gain. There exists a definite lower limit of input signal and consequently of amplifier gain, established by the magnitude of the tube noise of the first amplifier tube. As the input signal is reduced to the order of magnitude of the tube noise it can no longer be discerned readily nor be analyzed correctly. This limit is reached as the input signal is reduced to less than 10 microvolts and is approached in the design of hot-wire circuits. (See curves e and f of fig. 11.)

Interference from tube noise can be reduced by the following measures:

- (a) Operation of the hot wire at high temperature
- (b) Choice of a tube of low noise level for the first amplifier stage
- (c) Low amplifier gain
- (d) It is to be noted that, all other things equal, tube noise affects the readings less at higher velocities than at low velocity

CALIBRATION

A number of calibration tests were performed to establish the characteristics of the instrument experimentally.

Static Calibration

Calibration tests for static response included measurements of the equilibrium conditions of various states of operation without regard to transient phenomena.

(a) Variation of heating current with velocity.— The static response of the circuit to variations of velocity past the hot wire was tested by measurement of the heating current required to maintain the hot wire at constant temperature. To this end the hot wire was supplied with a heating current, i_0 , at zero airspeed by adjustment of the variable bridge resistor and then balanced. Once adjusted this balance was maintained automatically at all speeds except for the small unbalance necessary to induce compensating action. Typical calibration curves are given in figure 12, in which the square of the heating current, i_0 , has been plotted against the square root of the velocity, \sqrt{V} , for one value of i_0 each for three different hot wires. The platinum wire was tested to 340 feet per second, the highest velocity it was believed capable of sustaining without suffering permanent strain, the other wires to the maximum airspeed obtainable with the test equipment. At first the hot wire was placed in the stream from a nozzle placed on discharge side of the blower (an aircraft-type supercharger). This was found to be unsatisfactory, however, because of large disturbances of hot-wire readings which soon were traced to temperature laminarization in the air stream originating in the blower. After placing the nozzle on inlet side of the blower these disturbances vanished and the results of figure 12 were obtained without further difficulty.

It is seen that the curve for platinum deviates from a straight line at a velocity of 150 feet per second. The deviation from straight line in the $i_0^2 - \sqrt{V}$ diagram is caused by strain of the wire. Strain effects depend on factors not readily controlled, such as the sag of the wire, and should therefore be looked for especially in hot-wire calibration, since the occurrence of strain probably establishes an upper

limit for the velocity range for which a hot wire may be applied. In the case of the nickel wire and the tungsten wire, strain effects did not become apparent within the range of velocities tested.

(b) Linearity of instrument reading with velocity.— It was found that the variation of plate current of the non-linear stage could be adjusted readily so as to be linear with the variation of wind velocity past the hot wire. This is effected by adjustment of the screen voltage of the non-linear stage. It may be done without the use of an air jet by reading the variation of plate current which takes place as successively various currents ($i - i_0$) related to the wind velocities by the heating current-velocity characteristic of the hot wire are impressed upon the current supply terminals of the Wheatstone bridge to flow in opposite direction to the heating current i_0 . Linearity, which may be thus established readily over all but the first tenth of the range of velocities, may be checked in the air stream. Results of a calibration test are given in figure 13.

(c) Directional characteristics.— Hot-wire readings of the instrument with linear characteristic taken at constant velocity but varying angle of incidence θ between direction of flow and hot wire are plotted in figure 14. The figure also shows in dot-and-dash lines the $\sqrt{\sin^2\theta}$ curve, and it is seen that the calibration curve displaced a few degrees follows this $\sqrt{\sin^2\theta}$ curve with reasonable approximation, except in the range from 0° to 6° angle of incidence. It can be stated that the hot-wire instrument measures the component of velocity in the transverse plane of the wire.

Calibration for Response to Fluctuations of High Frequency and Large Amplitude

(a) Theory of square-wave testing.— The theory of the square-wave method is based upon the mathematics of the unit function of Fourier's series (references 4 and 5). The theory and application of square-wave testing of alternating current and electronic circuits has been discussed in reference 6.

With reference to its application to hot-wire response, it may safely be assumed that interference between states of

operation which are more than half a period of the square wave apart are of no concern. For this reason the theory may be confined to the study of the instantaneous change from one condition to another condition, where both the initial and the final conditions are maintained constant over an indefinite period. This change is represented graphically by curve a of figure 15.

Equivalent circuit.— The characteristics of the hot-wire circuit are represented by the equivalent electrical circuit (fig. 16). A decrease of velocity past the hot wire corresponds to an increase of current through the equivalent circuit. The resistance R and the capacitance C represent the resistance of the hot wire and its residual thermal inertia as well as the reduced capacitance of the circuit. Variations of the resistance of the hot wire, which in a circuit with automatically balanced bridge are small, are not taken into account in the equivalent circuit.

Suddenly applied voltage.— The instantaneous application of a voltage is described by the function:

$$e_1 = \int_{\omega=0}^{\omega=\infty} \frac{E}{\pi\omega} \sin(\omega t) d\omega$$

Let the resistance R_1 (fig. 16) be of such magnitude that the effect upon the current i through the circuit of the combined impedance

$$Z = \frac{R}{1 + \omega^2 C^2 R^2} - \frac{j \omega C R^2}{1 + \omega^2 C^2 R^2}$$

of the resistance R and the capacitance C acting in parallel may be neglected. In that case the equation for the current is:

$$i = \frac{E_1}{R_1} \int_{\omega=0}^{\omega=\infty} \frac{1}{\pi\omega} \sin(\omega t) d\omega$$

and the potential across the resistance R or capacitance C :

$$e = \frac{E_1}{R_1} R \left[\frac{1}{\pi} \int_{\omega=0}^{\omega=\infty} \frac{1}{\omega} \frac{\sin(\omega t)}{1 + \omega^2 C^2 R^2} d\omega - \frac{1}{\pi} \int_{\omega=0}^{\omega=\infty} \frac{CR}{1 + \omega^2 C^2 R^2} \cos(\omega t) d\omega \right]$$

where $\cos(\omega t)$ has been substituted for $j \sin(\omega t)$.

The first integral in brackets is of the form

$$\frac{1}{x(1+x^2)} \sin(mx) dx$$

as will be seen when substituting

$$x = \omega RC$$

$$m = \frac{t}{RC}$$

its value is (reference 7, item 445)

$$\pi - \frac{\pi}{2} e^{-t/RC}$$

The second integral in brackets is of the form

$$\int_0^{\infty} \frac{1}{1+x^2} \cos(mx) dx$$

x and m denoting the same quantities as above. The value of this integral is (reference 7, No. 263, p. 27)

$$\frac{\pi}{2} e^{-\frac{t}{RC}}$$

When substituting these values, the function $e = f(t)$ becomes

$$e = \frac{E_1}{R_1} R \left[1 - e^{-\frac{t}{RC}} \right]$$

This relation is represented by curve b, figure 15.

Geometrical representation of the time constant. - The quantity RC has been recognized as the time lag M . (See sec. on Response to Fluctuations of Velocity.) This quantity may be related to the response curve of an instantaneous change, curve b of figure 15, in two distinct ways, as shown below:

1. Differentiate the equation for e of the preceding paragraph with respect to time at $t = 0$

$$\left(\frac{de}{dt}\right)_{t=0} = \left(\frac{E_1}{R_1} \times \frac{R}{RC} \times e^{-\frac{t}{RC}}\right)_{t=0}$$

where $E = \frac{E_1}{R_1} R$, the voltage of the final state

when rearranging: $M = RC = \frac{E}{\left(\frac{de}{dt}\right)_{t=0}}$ which is

represented by the distance 1-2 in figure 15.

2. Calculate the ordinate of the response curve, curve b of figure 15, for the time $t = RC = M$

$$(e)_{t=RC} = E (1 - e^{-1}) = 0.632 E$$

where, $E = \frac{E_1}{R_1} R$, as above.

From this it follows that the time constant M may be obtained as the horizontal distance from the start of the response curve to the ordinate $e = 0.632 E$.

Response to noninstantaneous changes. - The first geometrical construction for M is identical to the construction applied to the response curve of a harmonic disturbance. (See reference 2, p. 12.) It may be concluded from this that the time constant may be obtained by either geometrical construction even in cases where the original impulse is not instantaneous, provided the curve of the applied voltage is known and compensated for by a corresponding horizontal displacement of the response curve.

The relations established in this section derived for a simple electrical circuit may be applied to the calibration

of a hot-wire circuit as it has been shown in the section on Response to Fluctuations of Velocity, that the combined characteristics of a hot wire and its circuit may be expressed through an ohmic resistance and an equivalent capacitance operating in parallel.

(b) Calibrating device for square-wave testing of the hot wire.— Changes of operating condition of the hot wire approximating those of square waves are produced by oscillating the hot wire at right angles to an air jet. The hot wire is arranged in such a manner that at the midpoint of its stroke, consequently at its maximum velocity, it enters the air jet simultaneously over its entire length. The axis of the wire, the direction of the air jet, and the direction of motion of the wire are at right angles with respect to each other. The mechanism of the calibrating device is shown in figure 17, which is believed to be self-explanatory. It operates at a stroke of $4\frac{1}{8}$ inches and at a frequency of 30 to 60 cycles per second. The velocity of the air stream may be varied from 0 to 400 feet per second.

In using the calibrating device, account must be taken of the fringe layer separating the free jet from the surrounding stagnant air. It should be reduced to minimum thickness by removing the boundary layer of the nozzle (see fig. 17) and by traversing the jet close to the throat of the nozzle. Correction must be made for the remaining fringe layer in evaluating the calibration records.

A sample oscillograph obtained with the square-wave calibrating device from a circuit with considerable time lag is shown in figure 18.

Measurements of the time lag of the hot-wire instrument with battery supply and with a tungsten wire of 0.00061 centimeter diameter and 0.80 centimeter length, carefully adjusted for maximum response indicate that in this case M is of the order of 10×10^{-8} second. Precise measurements, however, were not possible, chiefly because of the disturbing effect of the fringe layer upon the measurement. Further development of the square-wave testing device is necessary to achieve higher speeds of the hot wire as it enters the air stream and thereby higher precision of measurement of small time lags.

MEASUREMENT OF MEAN VELOCITY OF AN AIR STREAM

The hot-wire instrument as described in the preceding paragraphs was used for measuring the mean velocity in two distinct cases, namely: (1) In a flow of varying velocity but of uniform direction in which, moreover, both the mean velocity and the character of the fluctuations could be ascertained precisely. (2) In a flow of cyclicly varying velocity and direction in which other measuring devices are not presumed to give precise results.

Measurement of Rectilinear Flow

The hot wire was mounted on a shaking device oscillating at from 30 to 60 cycles per second through a stroke of 6 inches in an air stream parallel to the direction of flow. The air stream was produced by a nozzle of 8 inches diameter, its velocity could be varied from 0 to 400 feet per second.

The tests then consisted of shaking the wire at various frequencies and at various velocities of the air stream, while at the same time observing the cathode ray oscilloscope and taking readings of the nonlinear stage.

The readings of the mean velocity confirmed the anticipation as it remained the same whether or not the hot wire was shaken, except in case the airspeed of the jet was less than the maximum speed of the shaker motion.

The oscillograph observation was less conclusive than the mean readings since it is difficult to detect slight deviation from a sine curve. Distinct indication, however, was obtained from the oscillograph as soon as the direction of relative velocity reverses—that is, the case referred to above when the instrument ceased to read the mean velocity.

Measurements of a Field of Flow of Varying

Velocity and Direction

An investigation was made of the possibility of measuring the mean axial velocity, as well as the instantaneous axial-velocity components at the discharge of a rotating blade row. A rotating axial-flow blade grid of 36-inch tip diameter

20-inch hub diameter, consisting of 12 blades of 7-inch chord and 8-inch span, rotating at from 600 to 1000 rpm, was available (reference 8). Directly downstream of this grid and rotating with it was mounted a pitot tube by means of which wake traverses could be measured while the grid was in operation.

Hot-wire measurements were obtained on this blade grid by placing a stationary hot wire at midspan radius of the blades approximately 1 inch axially downstream of the trailing edges such that the hot wire was directed in the plane of rotation tangential to a circle concentric to the axis of rotation. The hot-wire instrument might then be expected, according to the section Directional characteristics, to give readings of the axial velocity components. The instantaneous reading was made visible on the screen of a cathode-ray oscilloscope. To this purpose the sweep circuit of the oscilloscope was synchronized with the rotation of the rotating grid by photocell circuit such that the velocity pattern of only one-blade interval appeared on the screen. An oscillograph thus obtained at midspan for 700 rpm and 120 feet per second mean axial velocity is shown in figure 19. At the same time, mean readings of the hot-wire instrument were taken.

The oscilloscope was evaluated from the known calibration characteristics of the hot-wire instrument and the deflection-voltage ratio of the oscilloscope, yielding the variation from mean of the instantaneous axial velocity and in conjunction with the mean reading of the instantaneous velocity.

Corresponding pitot tube measurements of a wake traverse relative to the rotating grid were evaluated to give a profile of instantaneous axial velocities. In this case variations of direction of the relative velocity which were not measured, had to be disregarded. The profiles of the axial-velocity components obtained from hot-wire readings and from pitot tube readings in the rotating system, shown in figure 20, show reasonably good correlation.

CONCLUSIONS

The investigation has shown that hot-wire circuits of the type described, operating at essentially constant resistance of the hot wire, respond to fluctuations of velocity at very small time lag.

It is possible, by means of a suitably adjusted amplifier stage, to obtain instrument readings proportional to the veloc-

ity of a flow of fluctuating velocity and of constant direction.

Directional calibration of the hot-wire instrument with linear reading reveals that within a wide range of variations of direction it is possible to obtain readings of the velocity component normal to the hot wire, from which it is concluded that in flow of varying velocity and direction the mean velocity component normal to the hot wire may be measured.

At high velocities both the strength and the strain sensitivity of hot wires must be considered. It appears that in this respect tungsten wire is most suitable. Suggestions are made for mounting tungsten wires.

Aerodynamics Laboratory,
Case School of Applied Science,
Cleveland, Ohio, December 13, 1944.

REFERENCES

1. King, Louis Vessot: On the Convection of Heat from Small Cylinders in a Stream of Fluid: Determination of the Convection Constants of Small Platinum Wires with Application to Hot Wire Anemometry. Phil. Trans. Royal Soc. (London), ser. A, vol. 214, 1914, pp. 373-432.
2. Dryden, H. L., and Kuethe, A. M.: The Measurement of Fluctuations of Air Speed by the Hot Wire Anemometer. NACA Rep. No. 320, 1929.
3. Gibbons, C. H.: The Use of the Resistance Wire Strain Gauge in Stress Analysis. Proc., Soc. for Experimental Stress Analysis, vol. 1, no. 1, 1943.
4. von Kármán, Th., and Biot, M. A.: Mathematical Methods in Engineering. McGraw-Hill Book Co. Inc., 1940, p. 327.
5. Shea, T. E.: Transmission Networks and Wave Filters. pp. 397-400.
6. Swift, G.: Amplifier Testing by Means of Square Waves. Communications, vol. 19, no. 2, Feb. 1939, pp. 22-24.

7. Campbell, G. A., and Foster, R. M.: Fourier Integrals for Practical Applications. Bell Telephone System Technical Monograph, 1931.
8. Weske, John R., and Marble, F. E.: Characteristics of Airfoils in an Axial-Flow Grid. Jour. Aero. Sci., vol. 10, 1943, pp. 289-294.
9. Weske, John R.: A Hot-Wire Circuit with Very Small Time Lag. NACA TN No. 881, 1941.

TABLE I.- CIRCUIT CONSTANTS, BATTERY-OPERATED INSTRUMENT

R_1	2,000 ohms	A_1 and A_2	ILN5 tubes
R_2	5,000 ohms	A_3	ISA6 GT tube
R_3	30 ohms	A_4	1 to 4 IS4 tubes in parallel
R_4	100,000 ohms	B_1	filament switch on R_5
R_5	500,000 ohms	B_2	filament switch on R_{13}
R_6	10,000 ohms	B_3	filament switch on R_3
R_7	3 megohms	S_2 and S_5	+180 volts to ground
R_8	10 megohms	S_1 and S_4	+90 volts to ground
R_9	600,000 ohms	S_6	ground
R_{10}	3 megohms	S_7	-90 volts to ground
R_{11}	1 megohms	S_3 and S_8	-180 volts to ground
R_{12}	5 megohms	G	galvanometer
R_{13}	500,000 ohms	D_1	(0 to 75) milli- ammeter
R_{14}	5 megohms	D_2	(0 to 100) micro- ammeter
R_{15}	100,000 ohms		

TABLE II.- CIRCUIT CONSTANTS, ALTERNATING-
 CURRENT SUPPLIED INSTRUMENT

R ₁	2,000 ohms	G	(0 to 100) milliammeter
R ₂	5,000 ohms	D ₁	(0 to 100) microammeter
R ₃	30 ohms	D ₂	galvanometer
R ₄	1,500 ohms		
R ₅	500,000 ohms	C ₁	0 to 100 mmf
R ₆	1.2 megohms	C ₂	0 to 30 mmf
R ₇	3 megohms		
R ₈	500,000 ohms	A ₁ , A ₂ , A ₃	6AG7 tubes
R ₉	1.2 megohms	A ₄	6-Y-6 tube
R ₁₀	200,000 ohms	A ₅	1/4-watt neon bulb
R ₁₁	1.8 megohms		
R ₁₂	100,000 ohms	B ₁	switch on R ₄ control
R ₁₃	50,000 ohms	For supply voltages at points S ₁ to S ₇ , see figure 4.	
R ₁₄	50,000 ohms		
R ₁₅	1.2 megohms		
R ₁₆	1,000 ohms	(S ₈ - S ₉)	6 volts d.c.

TABLE III.-- POWER SUPPLY

A ₁	Thordarson, T-13R12 or equivalent.
A ₂	Utah, 660 or equivalent
A ₃	Thordarson, T-19P54 or equivalent
A ₄	filament transformer, 5 volts 2A
(L ₁ - L ₂)	shielded filter choke 20 hy 50 MA
(L ₃ - L ₄)	shielded filter choke 15 hy 200 MA
C ₁ , C ₂ , C ₃ , C ₄ , C ₅	electrolytic condenser 20 MFD 450 volts
C ₆	16 MFD
R ₁	400 ohms, 1/2 watt
R ₂ and R ₅	6000 ohms, 1/2 watt
R ₃ and R ₆	100 ohms, 10 watts
R ₄	2000 ohms, 2 watts
R ₇	1000 ohms, 50 watt, with adjustable tap
R ₈	1000 ohms, 1/2 watt
R ₉ , R ₁₀ , R ₁₁ , R ₁₂	700 ohms, 1 watt
R ₁₃	75 ohms, with adjustable tap
R ₁₄	7500 ohms, 1 watt

HOT WIRE CIRCUIT

WITH VERY SMALL TIME LAG

CIRCUIT ELEMENTS SCHEMATIC

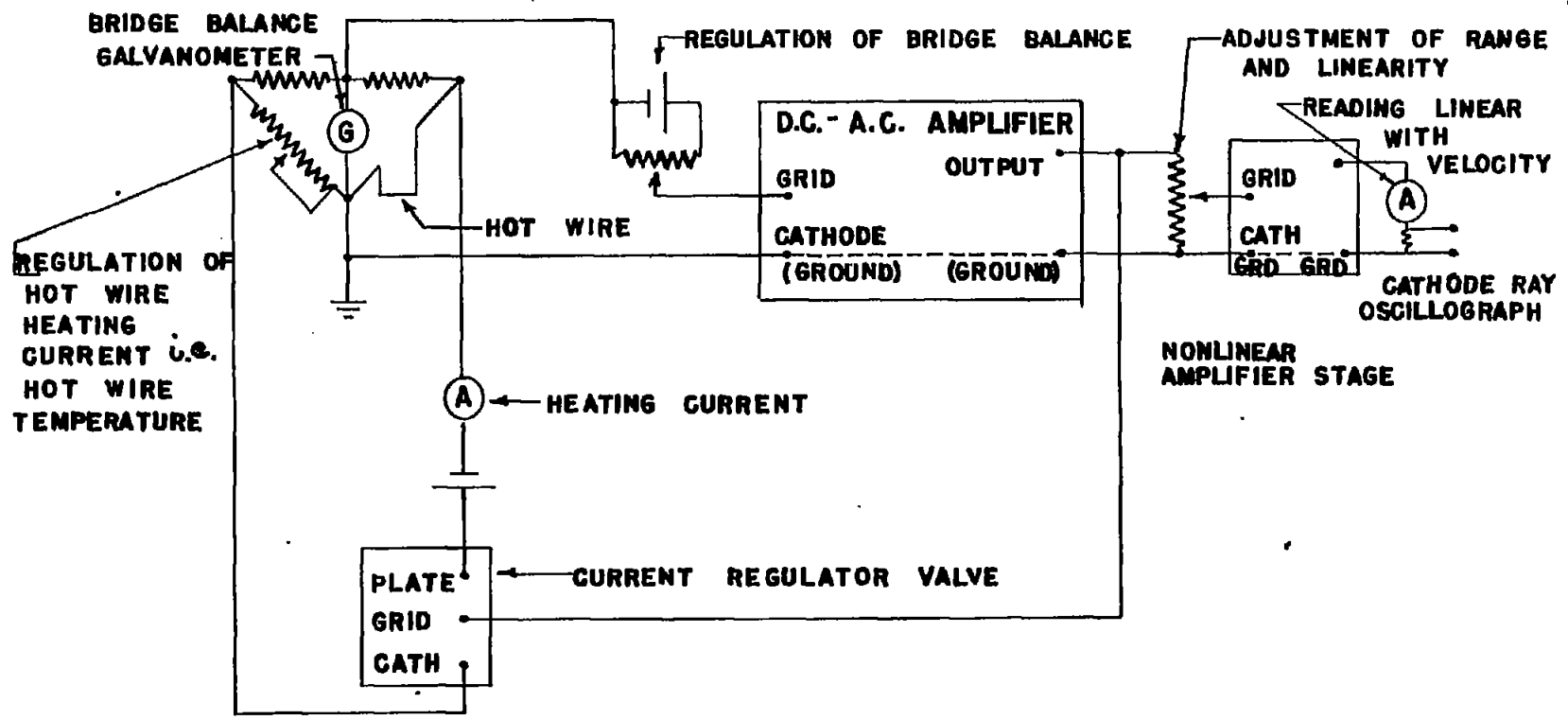
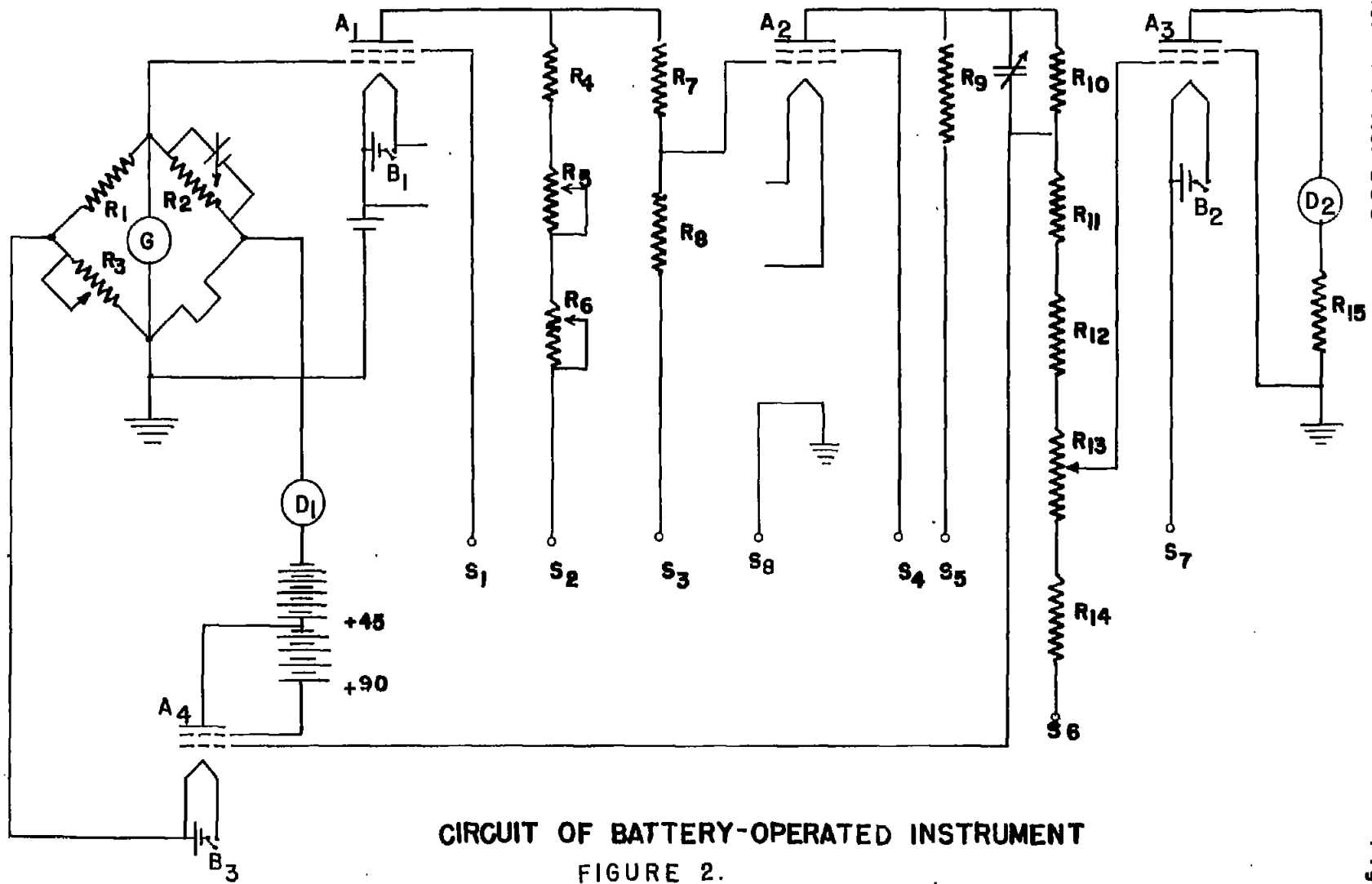

FIGURE 1.- COMPONENTS OF THE HOT WIRE INSTRUMENT, SCHEMATIC.

NACA TN No. 990

Fig. 1



CIRCUIT OF BATTERY-OPERATED INSTRUMENT
FIGURE 2.

NACA TN No. 990

Fig. 2

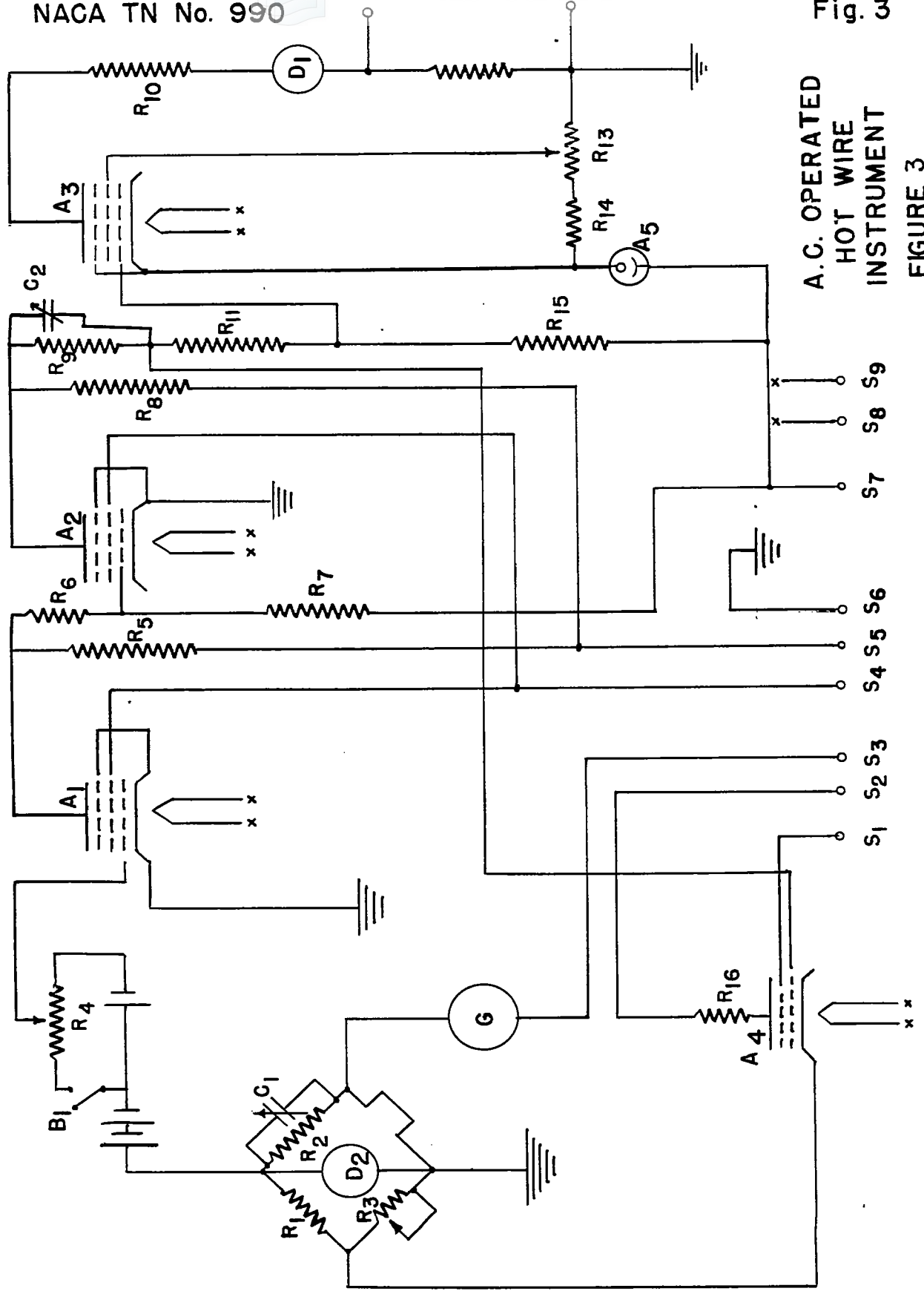

A.C. OPERATED
HOT WIRE
INSTRUMENT
FIGURE 3

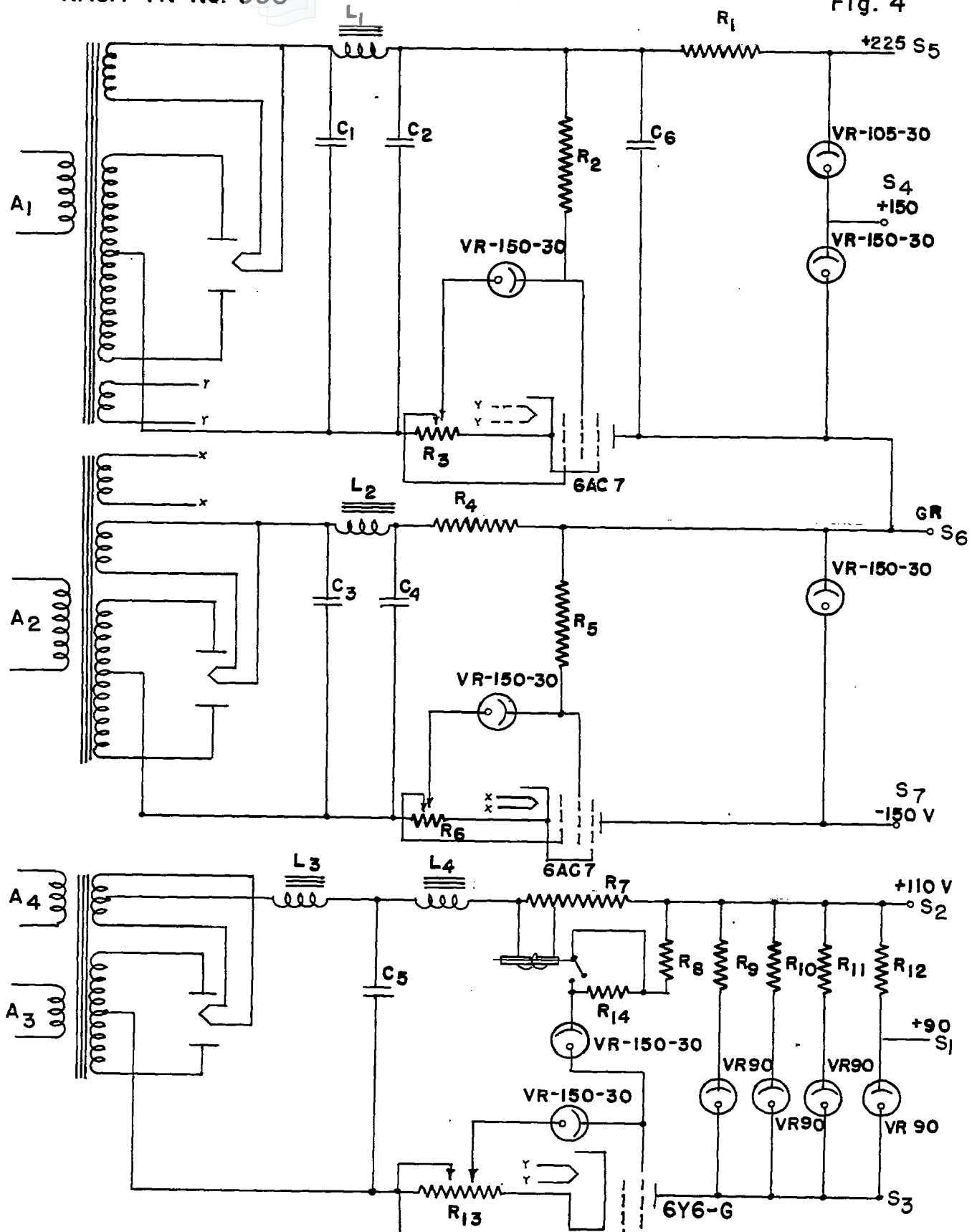
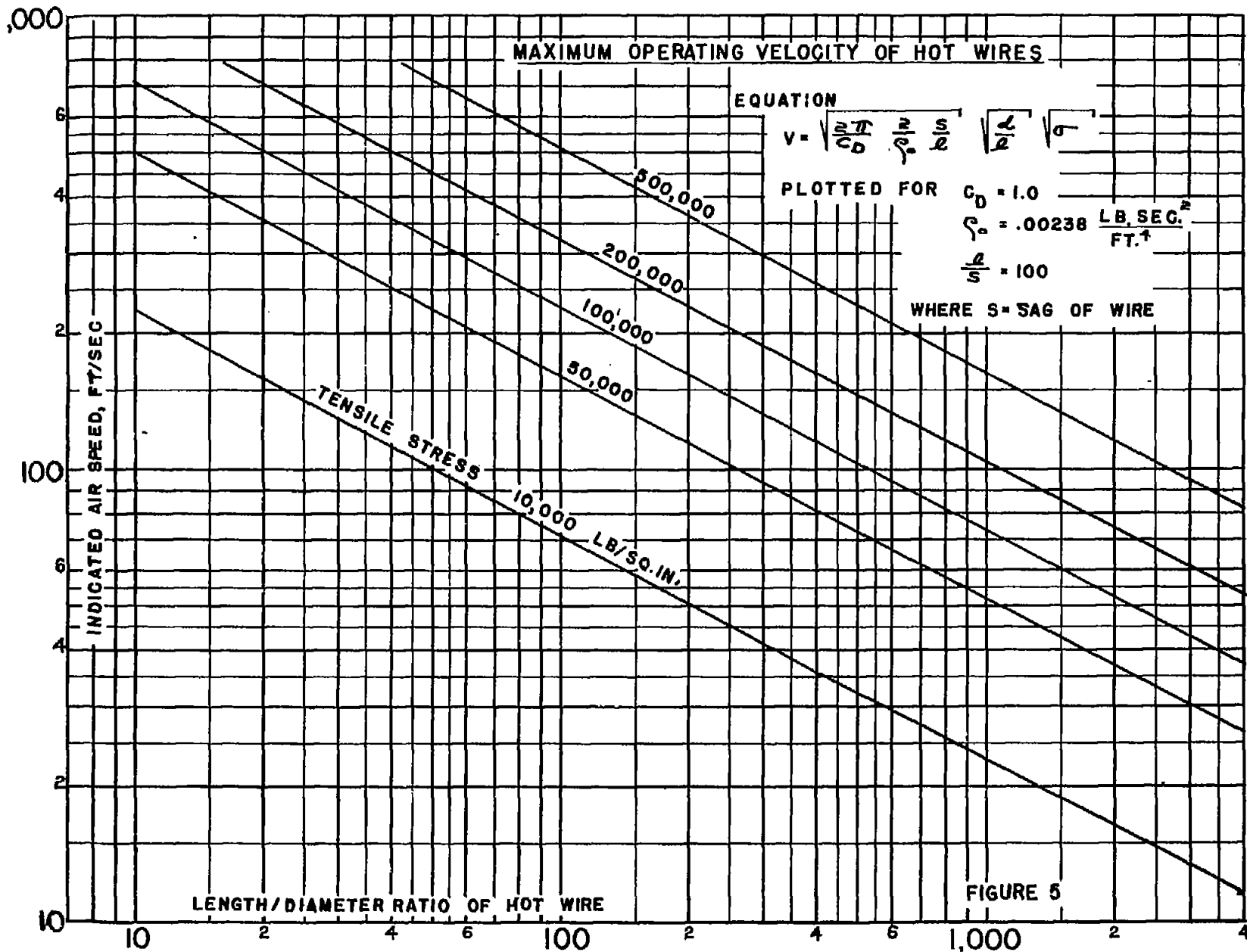
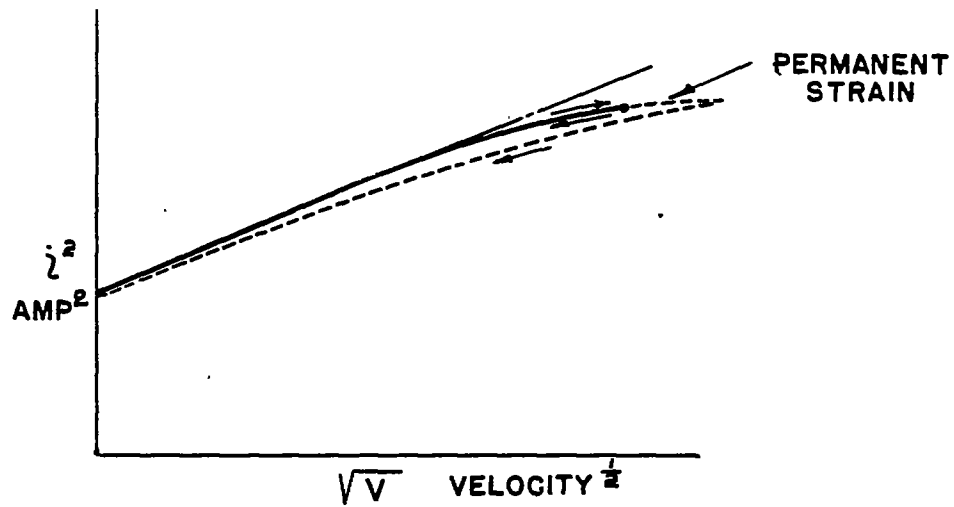

FIGURE 4.- CIRCUIT OF POWER PACKS FOR A.C. SUPPLIED INSTRUMENT.





DEVIATION FROM KING'S EQUATION
AS A RESULT OF STRAIN SENSITIVITY

FIGURE 6

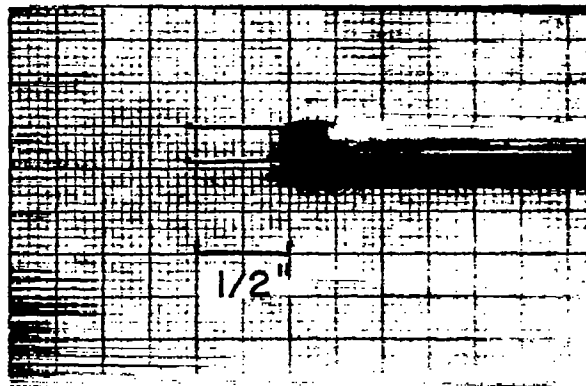

HOT WIRE HOLDER FOR TUNGSTEN WIRE

FIGURE 8

METHOD OF MOUNTING TUNGSTEN WIRE

NACA TN NO. 990

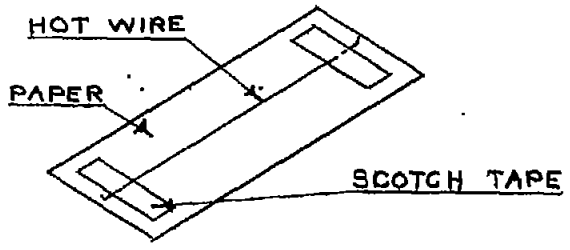

(a) HOT WIRE PREPARED FOR ELECTROPLATING

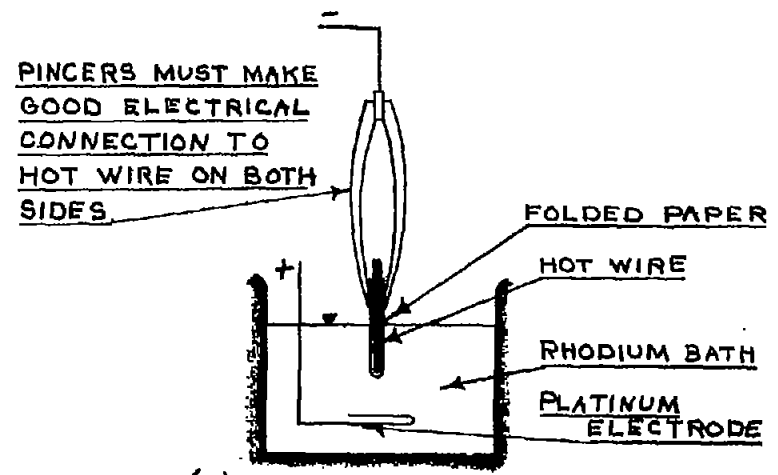

(b) ELECTROPLATING

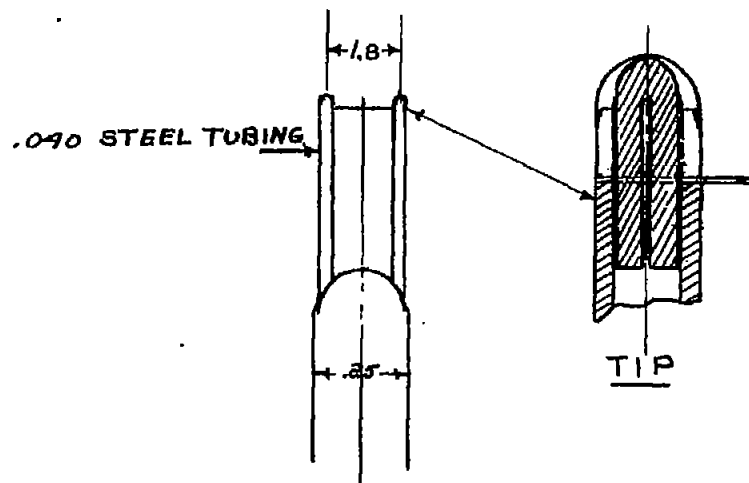

(c) MOUNTED TUNGSTEN HOT WIRE, AFTER SOLDERING.

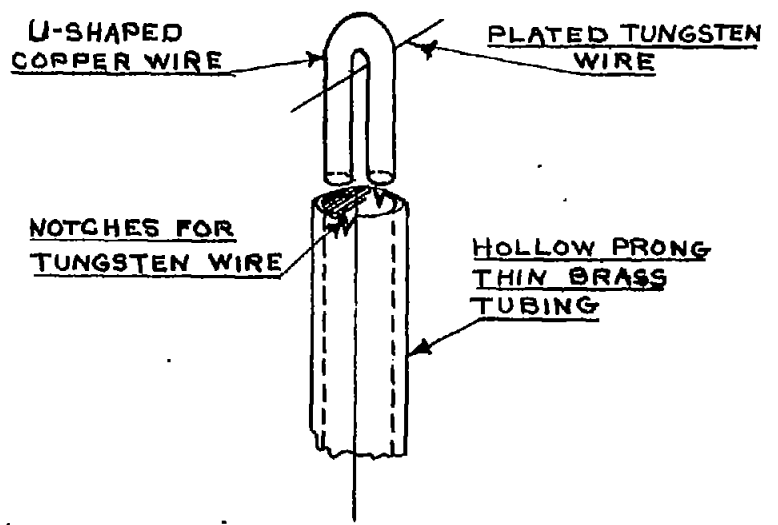

(d) EXPLODED MAGNIFIED VIEW OF CONNECTION TO PRONG.

Figure 7.

Fig. 7

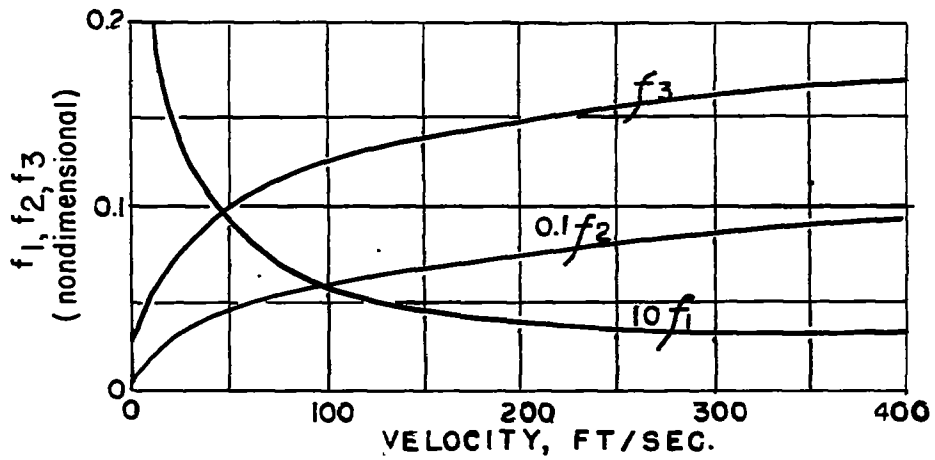

STATIC RESPONSE CHARACTERISTICS OF HOT WIRES
AT CONSTANT RESISTANCE OPERATION

FIGURE 9

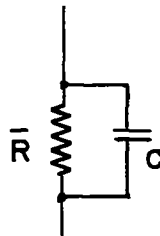

ELECTRICAL EQUIVALENT OF THE
HOT WIRE

FIGURE 10

LEGEND

- Curve (a), for Pt wire at 5000 cycles, $l/d = 2540$,
.00025 cm dia
- Curve (b), for Pt wire at 10000 cycles, $l/d = 2540$,
.00025 cm dia
- Curve (c), for W wire at 5000 cycles, $l/d = 1040$,
.00061 cm dia
- Curve (d), for W wire at 10000 cycles, $l/d = 1040$,
.00061 cm dia

Upper limit for μ' for 10 percent maximum noise in the reading of a 1 percent velocity variation at mean operating conditions.

- Curve (e), for Pt wire, .00025 cm dia
- Curve (f), for W wire, .00061 cm dia

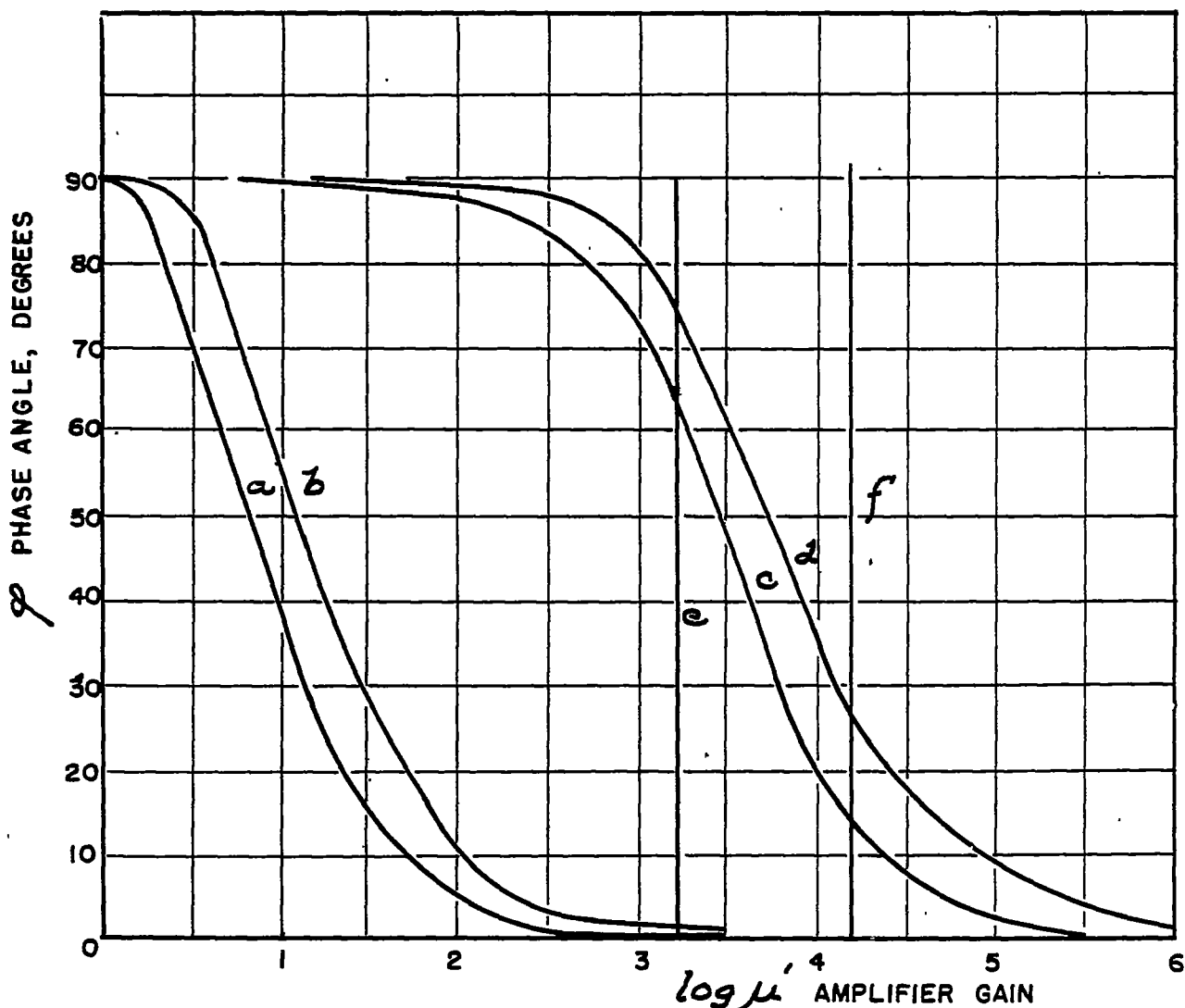

DYNAMIC CHARACTERISTICS OF CIRCUIT RESPONSE

FIGURE 11

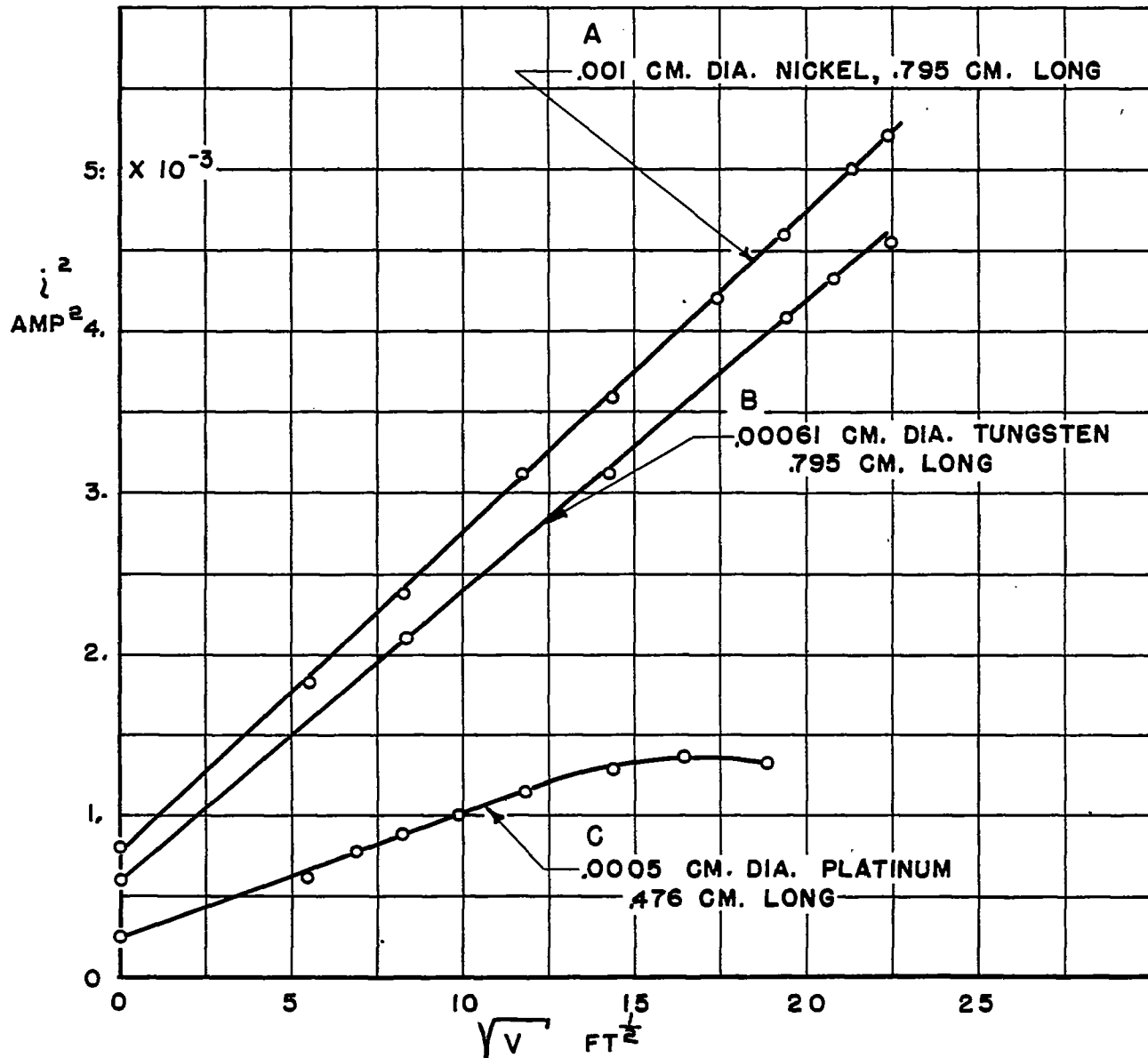

VARIATION OF HEATING CURRENT WITH VELOCITY

FIGURE 12

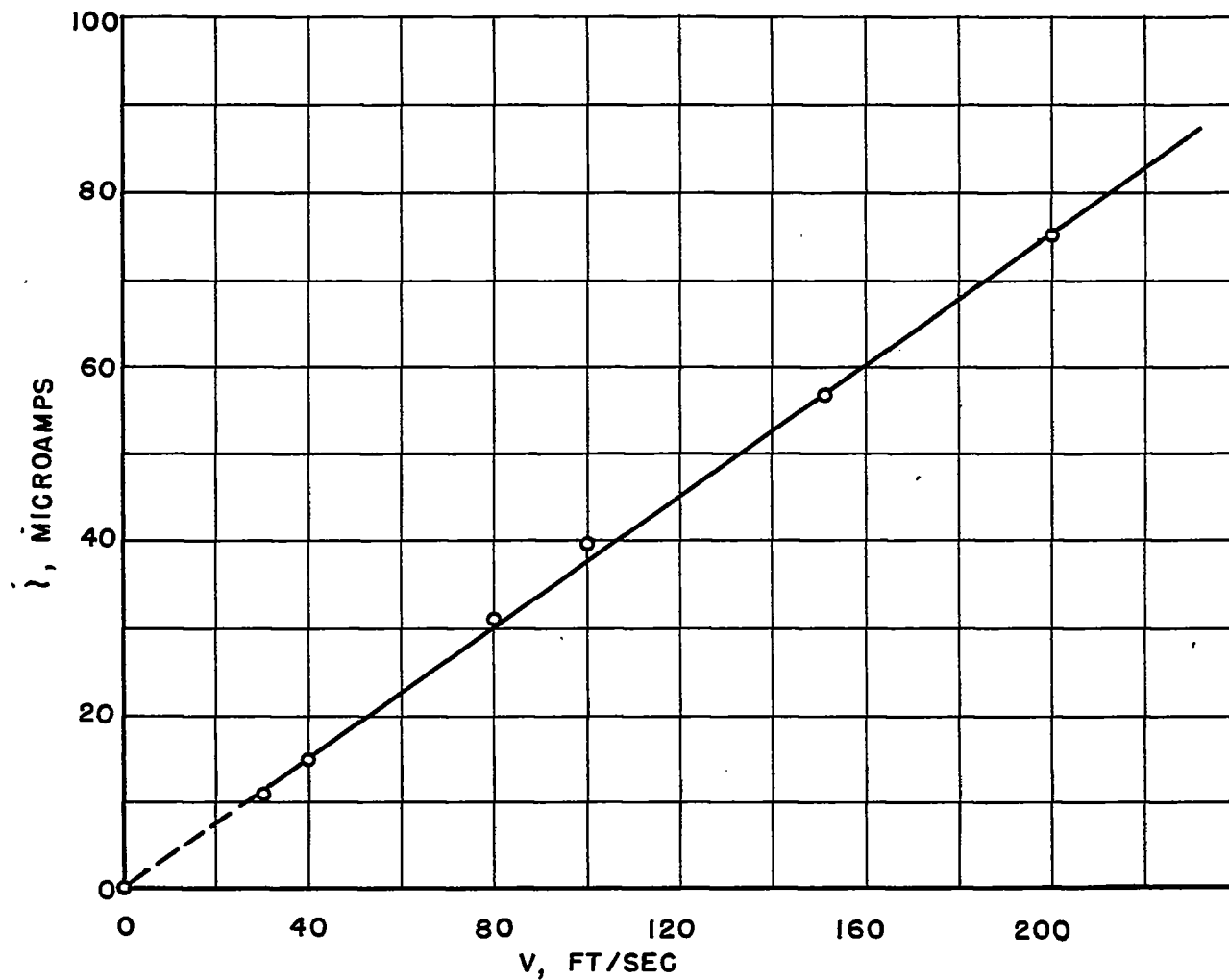

CALIBRATION FOR LINEARITY OF READING WITH VELOCITY

FIGURE 13

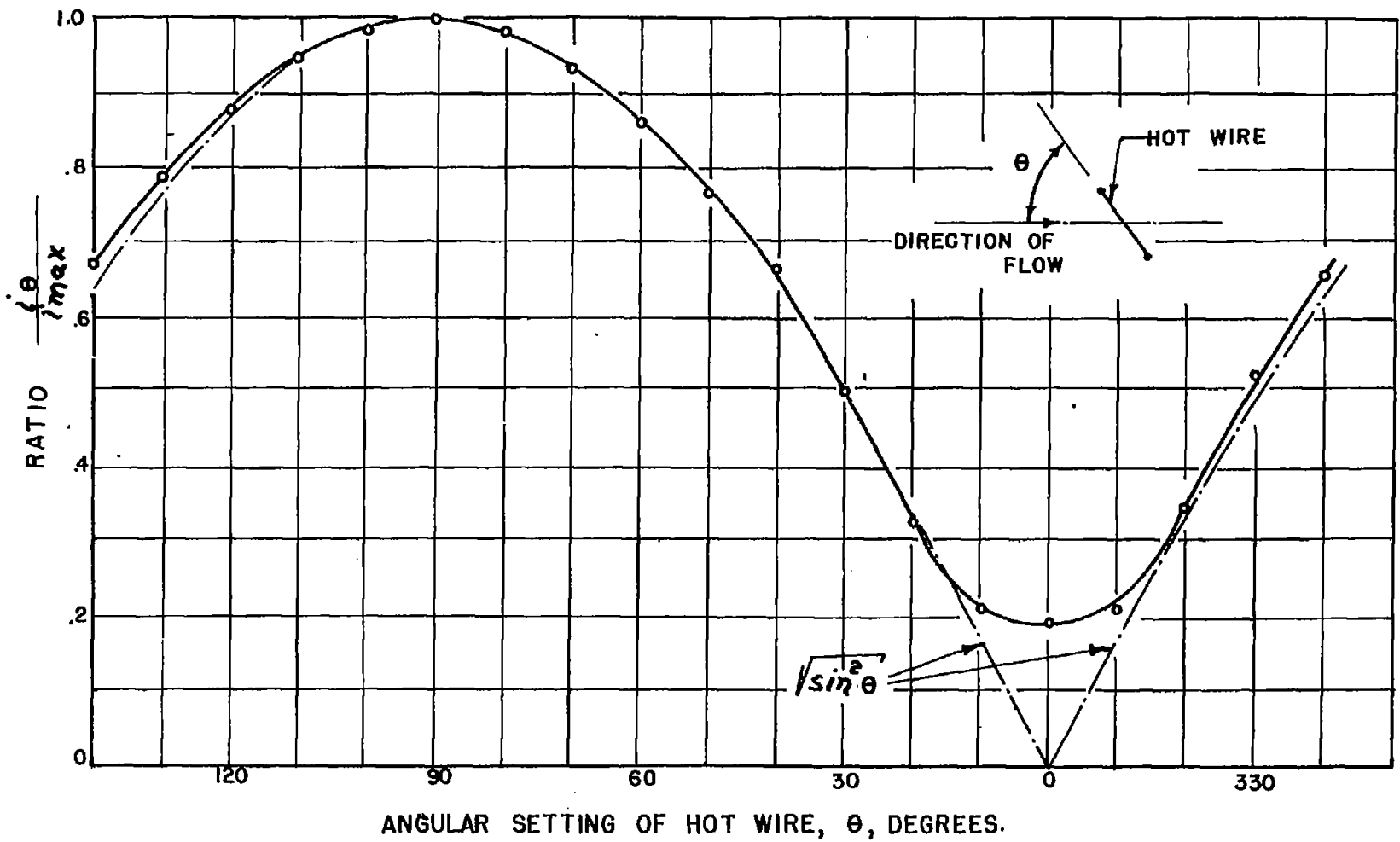

NACA TN No. 990

DIRECTIONAL CHARACTERISTICS OF HOT WIRE AT CONSTANT RESISTANCE

FIGURE 14

Fig. 14

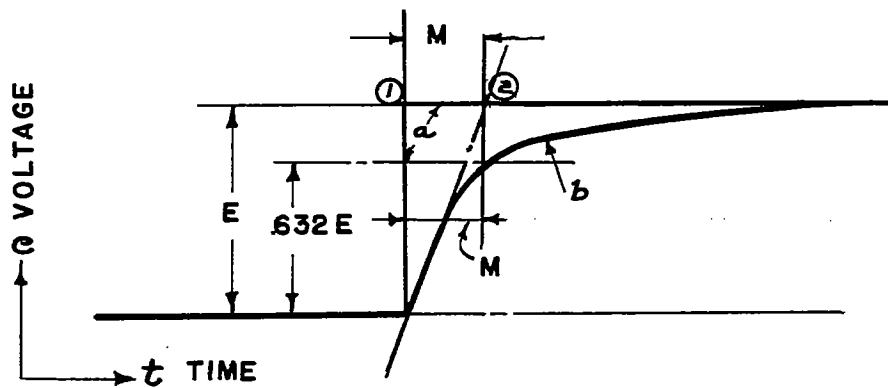

RESPONSE TO AN INSTANTANEOUS CHANGE OF VELOCITY

FIGURE 15

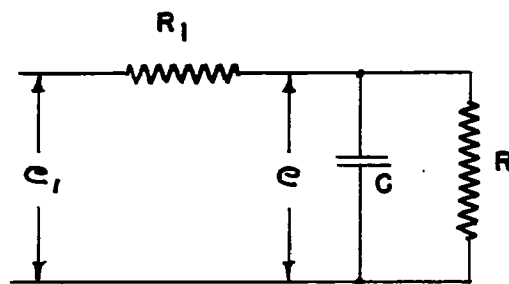

EQUIVALENT CIRCUIT

FIGURE 16

LEAD TO THE
HOT WIRE INSTRUMENT

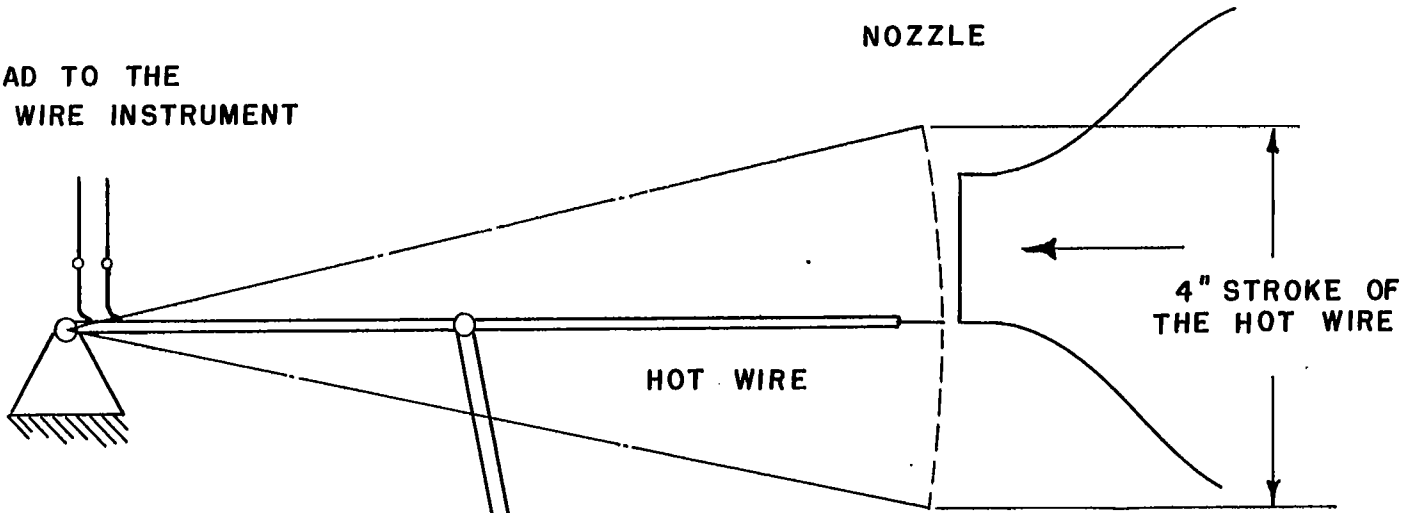

HOT WIRE

NOZZLE

4" STROKE OF
THE HOT WIRE

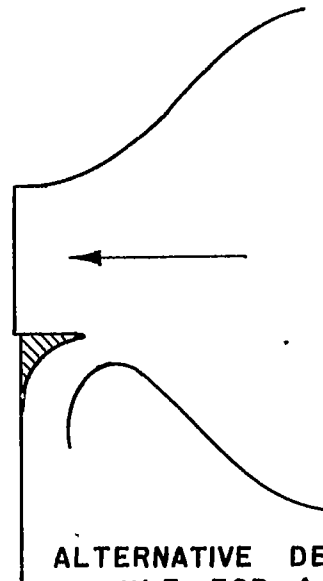
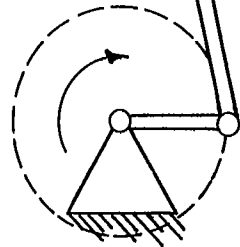

ALTERNATIVE DESIGN OF THE
NOZZLE FOR A VERY THIN
TRANSITION LAYER OF THE JET

CALIBRATING DEVICE FOR HOT WIRE RESPONSE

FIGURE 17

NACA TN No. 990

Fig. 17



FIGURE 18.- OSCILLOGRAPH OF SQUARE
WAVE CALIBRATION.

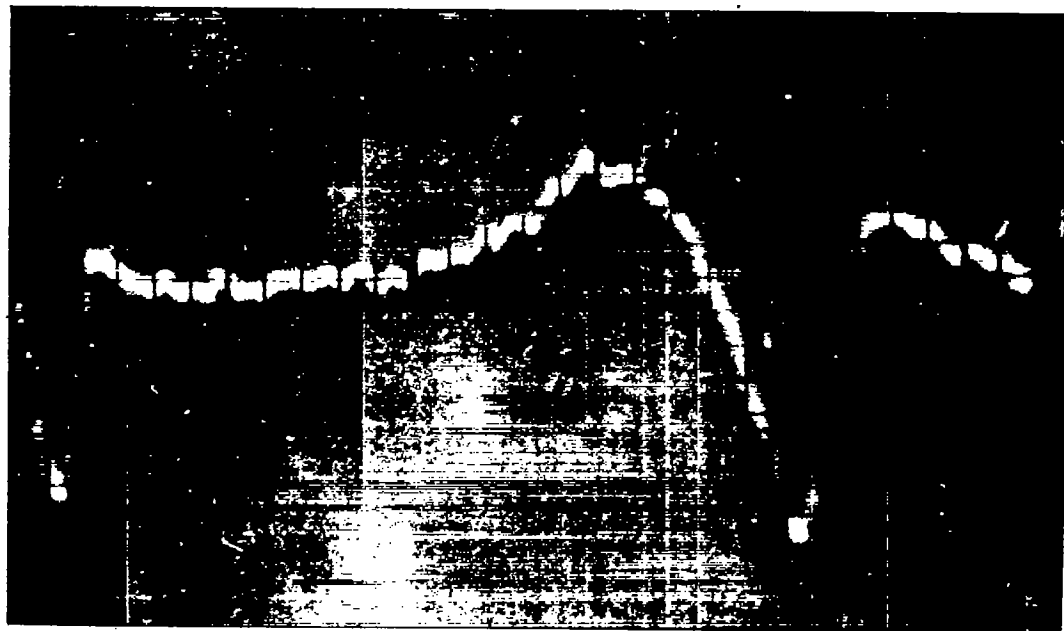

FIGURE 19.- INSTANTANEOUS VELOCITY PROFILE.

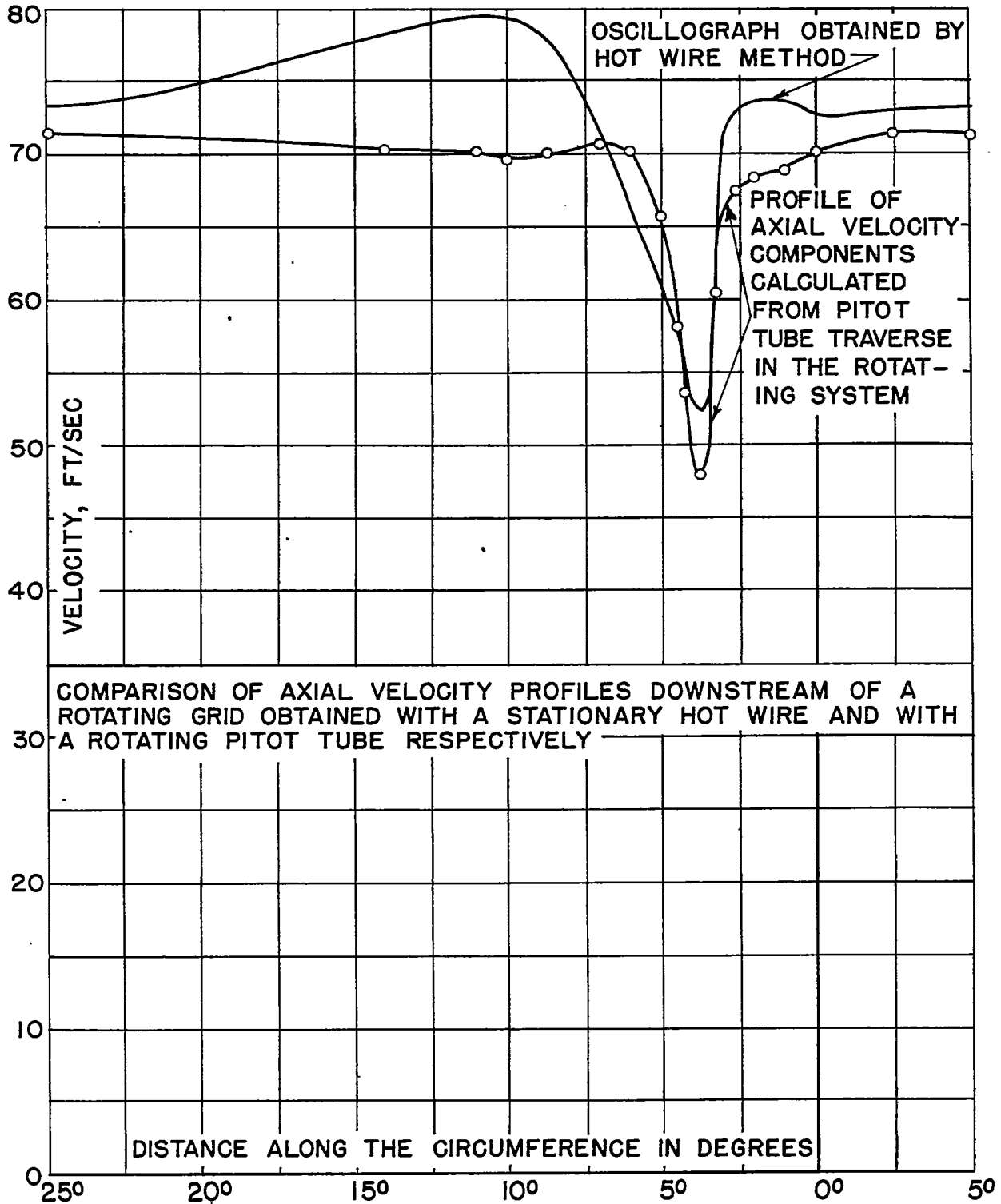

FIGURE 20