

ACR Nov. 1940

FEB 1947

~~CONFIDENTIAL~~
~~CONFIDENTIAL~~
~~CONFIDENTIAL~~
~~CONFIDENTIAL~~
~~CONFIDENTIAL~~

NATIONAL ADVISORY COMMITTEE FOR AERONAUTICS

WARTIME REPORT

ORIGINALLY ISSUED
November 1940 as
Advance Confidential Report

WIND-TUNNEL INVESTIGATION OF AN NACA 23012 AIRFOIL

WITH TWO SIZES OF BALANCED SPLIT FLAP

By Thomas A. Harris and Paul E. Purser

Langley Memorial Aeronautical Laboratory
Langley Field, Va.

CONFIDENTIAL
CONFIDENTIAL
CONFIDENTIAL
CONFIDENTIAL



WASHINGTON

NACA WARTIME REPORTS are reprints of papers originally issued to provide rapid distribution of advance research results to an authorized group requiring them for the war effort. They were previously held under a security status but are now unclassified. Some of these reports were not technically edited. All have been reproduced without change in order to expedite general distribution.

3 1176 01365 5247

WIND-TUNNEL INVESTIGATION OF AN NACA 23012 AIRFOIL WITH TWO SIZES OF BALANCED SPLIT FLAP

By Thomas A. Harris and Paul E. Purser

SUMMARY

L-441

An investigation has been made in the NACA 7- by 10-foot wind tunnel of an NACA 23012 airfoil with a 15-percent-chord and a 25-percent-chord balanced split flap of the Clark Y profile. The investigation was made to determine the aerodynamic section characteristics of the airfoil as affected by the size, nose location, and deflection of the flap. Complete aerodynamic section characteristics were determined for several nose locations of each flap and are presented for four typical locations for each flap. A comparison of the drag and lift characteristics is made with two other medium-chord flaps previously investigated.

The optimum arrangement of either of the balanced split flaps, from consideration of maximum lift coefficients and minimum profile-drag coefficients for take-off and climb, was a combination comparable to the Fowler flap. When compared on a basis of flap deflection for equal maximum lift coefficients, there was little difference in the pitching-moment coefficients for any of the arrangements tested. Any leak between the nose of the flap and the lower surface of the wing was harmful from consideration of maximum lift coefficient, but if the gap was increased to form a suitable slot the maximum lift coefficient was increased. The results of this investigation furnish data suitable for application to the design of any probable split-flap arrangement.

INTRODUCTION

An investigation of various high-lift devices has been undertaken by the NACA to provide designers with aerodynamic and structural data for the design of wing-flap combinations for improved safety and performance of airplanes. Aerodynamic data for single-slotted flaps on airfoils of various thicknesses have been made available in references 1 through 6, for Fowler and plain flaps on 12-percent thick airfoils in reference 1, and for split flaps on airfoils of various thicknesses in reference 7. Structural data for the single-slotted flaps are presented in references 8 and 9, for the plain flap in reference 8, for the split flap in reference 9, and for the Fowler flap in reference 10.

Since most of the flaps in general use today are some form of split flap, the investigation was extended to flaps of the balanced split type and the present report presents aerodynamic data for two sizes of balanced split flap on an NACA 23012 airfoil.

APPARATUS AND TESTS

Models

The basic airfoil was built to the NACA 23012 profile, the ordinates of which are given in table I. It has a span of 7 feet and a chord of 3 feet, and is the same basic airfoil used in reference 2. The rear portion of the airfoil is removable so that flaps of various sizes can be used.

The 15-percent-chord and the 25-percent-chord flaps were built of laminated mahogany to the Clark Y profile (table I). The span of each flap was 7 feet and the chords were 5.4 inches and 9 inches which are, respectively, 15 and 25 percent of the wing chord. The flaps were rigidly attached to the main wing by four steel fittings which allowed a wide selection of nose locations for each flap and permitted deflecting the flaps from 0° to 60° in 10° increments at each location (fig. 1). The nose point of the flap is defined as the point of tangency of the flap leading-edge arc and a line drawn perpendicular to the flap chord.

The models were made to a tolerance of ± 0.015 inch.

Tests

Tunnel mounting.— The models were mounted in the closed test section of the NACA 7- by 10-foot wind tunnel so that they completely spanned the jet except for small clearances at either end (references 1 and 11). The main airfoil was rigidly attached to the balance frame by torque tubes which extended through the upper and lower boundaries of the tunnel. The angle of attack of the model was set by rotating the torque tubes with a calibrated drive from outside the tunnel. This type of installation closely approximates two-dimensional flow and therefore the section characteristics of the model being tested can be determined.

Test conditions.- A dynamic pressure of 16.37 pounds per square foot was maintained for all tests, which corresponds to a velocity of about 80 miles per hour under standard sea-level conditions and to an average test Reynolds number of about 2,190,000. Because of the turbulence in the wind tunnel the effective Reynolds number, Re , (reference 12), was approximately 3,500,000. Re , for all tests, is based on the chord of the airfoil with the flap retracted (3 ft), and on a turbulence factor of 1.6 for the wind tunnel.

Test of the balanced split flap.- The regular tests consisted of force and moment measurements with each flap at each of 16 positions. Data were obtained at each flap position at flap deflections from 0° to 60° in 10° increments. The complete angle-of-attack range from -6° to the angle of attack for maximum lift was covered in 2° increments for each test. No data were obtained above the stall because of the unsteady condition of the model.

RESULTS AND DISCUSSION

Coefficients

All the test results are given in standard nondimensional section coefficient form, corrected as explained in reference 1.

- c_l section lift coefficient (l/qc)
- c_{d_0} section profile-drag coefficient (d_0/qc)
- $c_{m(a.c.)_0}$ section pitching-moment coefficient about the aerodynamic center of the plain airfoil ($m_{(a.c.)_0}/qc^2$)

where

- l section lift
- d_0 section profile drag
- $m_{(a.c.)_0}$ section pitching moment

q dynamic pressure ($\frac{1}{2} \rho v^2$)

c chord of the basic airfoil with flap retracted

and

α_o angle of attack corrected to infinite aspect ratio

δ_f flap deflection, measured between the airfoil chord line and the flap chord line

Precision

The accuracy of the various measurements is believed to lie within the following limits:

α_o $\pm 0.1^\circ$	$c_{d_o}(c_l=1.0)$ ± 0.0006
$c_{l_{max}}$ ± 0.03	$c_{d_o}(c_l=2.5)$ ± 0.002
$e_m(a.c.)_o$ ± 0.003	δ_f $\pm 0.2^\circ$
$c_{d_{o_{min}}}$ ± 0.0003	flap position $\pm 0.001c$

No corrections were applied for the effect of the hinge fittings since their effect was believed to be small. The same fittings were used on both flaps, therefore the relative merit of the two should not be affected. No attempt was made to determine the effect of the break in the airfoil lower surface at the forward end of the retracted flap (fig. 1), since a simple cover may be used to seal the break when the flap is retracted.

Determination of Optimum Flap Arrangements

Maximum lift. - Contours of flap nose location for $c_{l_{max}}$ are presented in figure 3 for the 0.15c balanced split flap. For flap deflections of 0° and 10° , the best location is at the trailing edge of the airfoil and 0.06c below the chord line. At deflections of 20° and 30° the point remains at the trailing edge but moves up to 0.015c below the chord line. The 30° flap deflection gave the highest maximum lift coefficient reached with the 0.15c

balanced split flap; the value was 2.68 and was slightly higher than was reached with the 0.2566c slotted flap 2-h (reference 1) at the same deflection. When deflected 40° or 50°, the flap stalled and the lift decreased slightly. The point for maximum lift moved to 0.05c ahead of the trailing edge and 0.03c below the chord line. At the 60° deflection the lift coefficient increased to nearly the value obtained at the 30° deflection, and there was little choice between locating the flap nose at the trailing edge on the chord line or locating it 0.05c ahead of and 0.015c below that point. It is interesting to note that locating the nose of the 0.15c flap 0.05c ahead of the airfoil trailing edge and 0.03c below the chord line gave, for deflections of 40° or over, a maximum lift coefficient nearly as high as that given by the usual Fowler arrangement. (See figs. 3a through 3g.)

The contours of flap location for $c_{l,max}$ for the 0.25c balanced split flap are shown in figure 4. For deflections of 0° and 10° the best location is the same as for the 0.15c flap, at the trailing edge of the wing with a 0.06c gap. At 20° and 30° the flap position for maximum lift remains at the airfoil trailing edge and moves up to 0.03c below the chord line. At 30° the 0.25c balanced split flap is superior to the 0.2566c slotted flap 2-h of reference 1, since it gave a maximum lift coefficient of 3.12. The 0.25c flap did not stall at 40°, the maximum lift coefficient increased to 3.22, and the best location was 0.015c below the chord line at the trailing edge of the airfoil. The flap did stall, however, at deflections of 50° and 60°, and the lift decreased. For the 50° deflection, the best location was at the trailing edge on the chord line, and at 60° the maximum lift coefficient was the same at the trailing edge on the chord line and at 0.015c below that point. The 0.25c flap differed from the 0.15c flap in that, for the larger flap, the Fowler arrangement was superior to any other arrangement from consideration of maximum lift coefficient. The dotted contours in figure 4 indicate that a leak or narrow gap between the flap nose and the airfoil is harmful for the intermediate flap positions. This is in agreement with the results in reference 13. The balanced split flap has an airfoil shape, however, and a gap is beneficial when the flap is in the intermediate positions provided the gap is over 2 percent of the airfoil chord in width. When the flap is fully extended and is deflected 20° to 40°, the gap is beneficial, provided it is less than 3 percent of the airfoil chord in width.

From the contours of flap location for $c_{l_{max}}$ in figures 3 and 4, the designer can determine the maximum lift coefficient to be expected at any flap location and deflection within the range tested. The contours are not closed for all flap deflections, but it is believed that a sufficient range of positions was investigated to cover any probable installation.

Minimum profile drag.— The contours of flap location for c_{d_0} for the 0.15c balanced split flap presented in figure 5, show that the plain airfoil gave the lowest drag at a lift coefficient of 1.0. At a lift coefficient of 1.5, the 0.15c flap gave a minimum c_{d_0} of 0.027 when deflected 20° and located 0.015c below the chord line at the trailing edge of the wing (fig. 6). This value is about the same as that given by the 0.2566c slotted 2-h and the 0.2567c Fowler flaps of reference 1. The minimum profile drag at a lift coefficient of 2.0 was also obtained with the flap deflected 20° and located 0.015c below the trailing edge of the wing. (See fig. 7.) The 0.2566c slotted flap 2-h (reference 1) gave a slightly higher profile drag at a lift coefficient of 2.0, while the 0.2667c Fowler flap gave the same value of the profile drag at this lift coefficient.

The flap position for minimum profile drag for both lift coefficients, 1.5 and 2.0, was very critical, the drag increasing rapidly with any movement of the flap. It therefore does not appear possible to obtain low profile drags, with the flap in the positions farther ahead where the maximum lift coefficients were large. Data were not available for plotting contours of minimum profile-drag coefficients at a lift coefficient of 2.5.

The 0.25c balanced split flap gave results (fig. 8) comparable with the results given by the 0.15c flap at a lift coefficient of 1.0. At a lift coefficient of 1.5 the minimum profile-drag coefficient was about 0.027 (fig. 9) with either the 10° or 20° deflections of the 0.25c flap when located 0.03c below the chord line at the trailing edge of the wing, which is comparable with the results for the 0.15c flap. When the nose of the flap is located 0.03c below the chord line at the trailing edge of the wing and deflected 20° , it was possible to reach a lift coefficient of 2.0 (fig. 10) with a profile-drag coefficient of 0.039, which is slightly lower than for the 0.15c

1-441
flap. At the same location and deflection, the 0.25c flap gave a lift coefficient of 2.5 (fig. 11) with a profile-drag coefficient of 0.056 compared with 0.055 for the 0.30c venetian-blind flap of reference 14, 0.062 for the 0.2657c Fowler flap, and 0.075 for the 0.2566c slotted flap 2-h of reference 1. At a lift coefficient of 2.0, the 0.25c flap was less critical to small changes in the nose location than the 0.15c flap, but both flaps had lower profile-drag coefficients for the Fowler arrangement than for locations farther forward.

The only explanation of the lower profile drag for the Fowler arrangement of the 0.25c flap than for the previously reported results of the Fowler wing (reference 1) is the use of the Clark Y section for the flap in the present tests, while for the previous tests the lower cambered 23012 section was used for the flap. An investigation of the effect of camber of the flap on the aerodynamic characteristics of the airfoil is indicated.

Using the contours of flap location for c_{d_0} in figures 5 through 11, the designer can determine very closely the value of profile-drag coefficient to be expected at any location of either flap within the range tested, for any deflection from 0° to 30° and for any lift coefficient from 1.0 to 2.0 for the 0.15c balanced split flap, and for any deflection from 0° to 40° and any lift coefficient from 1.0 to 2.5 for the 0.25c balanced split flap.

Pitching moment.— The contours of flap location for $c_{m(a.c.)_0}$ in figures 12 through 18, show for both balanced split flaps that the negative pitching moments at the best locations were nearly twice those of the simple split flap, and that they increased progressively as the flaps approached their best locations. When the balanced split flaps were located and deflected to give the same maximum lift coefficients as the split, plain, or slotted flaps of reference 1, the pitching-moment coefficients were only slightly larger than for the plain and split flaps and were about equal to those of the slotted flap 2-h. In the selection of an airfoil-flap combination for a given airplane, the pitching-moment coefficient should be determined for combinations that give equal maximum lifts in order to obtain an unbiased comparison.

With contours of flap location for $c_{m(n.c.)_0}$ in

figures 12 through 18, the designer can determine the pitching-moment coefficients of both wing-flap combinations within the range investigated.

Effect of sealing gap.— Several tests were made with the 0.25c balanced split flap to determine the effect of sealing the gap between the flap nose and the airfoil. The results of these tests are presented with the contours in figures 4, 8 to 11, and 15 to 18. In nearly all cases, sealing the gap increased the lift, drag, and pitching-moment coefficients. These data will afford the designer additional information on the aerodynamic characteristics of a split flap deflected downward and moved to the rear.

The selection of the optimum arrangements of the balanced split flaps from a consideration of the maximum lift coefficient, minimum profile-drag coefficient for take-off, and pitching-moment coefficient will have to be a compromise in which structural simplicity will play an important part. The data previously presented show that the optimum arrangement of either the 0.15c or 0.25c flap is an arrangement comparable to a Fowler flap from consideration of maximum lift and minimum profile-drag coefficients. Complete section data are therefore given for the Fowler arrangements. In addition, the complete section data are given for several other representative arrangements.

Aerodynamic Section Characteristics

The aerodynamic section characteristics of the NACA 23012 airfoil with the 0.15c and 0.25c balanced split flaps at each of four flap-nose locations, are presented in figures 19 through 26. The angle of attack, α_0 , for maximum lift varied from 12° to 15° for both flaps but was about the same as for the 0.2566c slotted flap 2-h of reference 1. There was an increase in the slope of the lift curve as the flaps were extended, which may be attributed to the increase in wing area. The four locations for which the aerodynamic section characteristics are given, are believed to be near any probable path that will be used in the application of the data to a design. The data presented in figures 19 through 26 should be sufficient, when used with the contours in figures 3 through 18, to allow the designer to predict the performance of any wing-flap combination within the range investigated.

11
 C. P. ...
 ...

Comparison of Flap Arrangements

The polars of profile-drag coefficient (figs. 27 and 28) show, as previously mentioned, that both the balanced split flaps are best when located in the usual Fowler position, at the trailing edge of the wing and slightly below the chord line. This flap position gave the highest values of maximum lift coefficient and the lowest values of profile-drag coefficient for take-off. The 0.15c flap, however, when located 0.05c ahead of the trailing edge and 0.03c below the chord line or on the chord line at the trailing edge of the wing, gave about the same maximum lift coefficient as the Fowler arrangement but gave larger profile-drag coefficients at all lift coefficients. The lift coefficients were larger, and the drag coefficients for given lift coefficients were lower, for the balanced split flap than for comparable simple split flaps of reference 7.

The comparison of pitching-moment coefficients should be made on the basis of flap deflections that give equal maximum lift coefficients. A comparison of the pitching-moment coefficients for the 0.15c flap set for take-off at four positions, is shown in the following table. In this table the maximum lift coefficient of the wing-flap combination was taken as 2.4, and it is assumed that take-off will be at $0.9c_{l,max}$ or at $c_l = 2.16$.

No.	Flap position		δ_f (deg.)	$c_{d,0.9c_{l,max}}$	$c_{m,0.9c_{l,max}}$	Data from figures
	x	y				
1	0.05c	0.06c	30	0.095	-0.250	19
2	.10c	.03c	20	.054	-.269	20
3	.15c	.015c	12	.054	-.267	21
4	.15c	0c	22	.060	-.280	22

An inspection of this table shows that the pitching-moment coefficient is lowest for flap position 1, but that the flap deflection and drag coefficient are much higher than for any of the other positions. The flap in the Fowler position, 3, gives the next lowest pitching-moment coefficient and requires only a 12° deflection of the flap. The reduction in profile-drag coefficient realized by using the Fowler arrangement, from 0.095 to 0.054, should immediately lead to the use of the Fowler flap in preference to the other arrangements if low drag for take-off is desired. The added mechanical complication of the Fowler arrangement appears to be the chief obstacle.

Comparison with Other Flaps

Envelope polars of profile-drag coefficients for the two balanced split flaps, the 0.2566c slotted flap 2-h (reference 1) and a 0.20c venetian-blind flap (reference 14), indicate that the 0.25c balanced split flap was best from the standpoint of profile-drag coefficients for take-off and climb (fig. 29). When the flaps are compared on the basis of pitching-moment coefficients with the flaps located and deflected to give equal values of the maximum lift coefficient, all of the flap arrangements are of about equal merit. The section maximum lift coefficient is largest for the 0.25c balanced split flap. The 0.20c venetian-blind flap and the 0.2566c slotted flap 2-h gave about the same maximum lift coefficient, while the 0.15c balanced split flap gave the lowest maximum lift coefficient of the arrangements compared.

CONCLUDING REMARKS

The optimum arrangement of either of the balanced split flaps, from consideration of maximum lift coefficients and minimum profile-drag coefficients for take-off and climb, was a combination comparable to the Fowler flap. The pitching-moment coefficients increased with flap deflection and with movement of the flap toward the trailing edge of the wing. When compared on a basis of flap deflection for equal maximum lift coefficients, however, there was little difference in the pitching-moment coefficients for any of the arrangements tested. With the 0.15c flap, the maximum lift coefficients were the same with the flap in the Fowler position and in a position 0.05c ahead of the trailing edge of the wing. In this position, however, the flap deflection required to obtain the maximum lift coefficient was twice as great as for the flap in the Fowler position and the profile-drag coefficients were much larger. Any leak between the nose of the flap and the lower surface of the wing was harmful from consideration of maximum lift coefficient, but if the gap was increased to form a suitable slot the maximum lift coefficient was increased. The results of this investigation furnish data suitable for application to the design of any probable split-flap arrangement.

The 0.25c balanced split flap gave higher maximum lift coefficients and lower profile-drag coefficients for take-

off than the best 0.2566c slotted flap previously developed. The characteristics of the 0.25c balanced split (Fowler) flap were also superior to a Fowler flap combination with a flap of small camber previously tested.

Langley Memorial Aeronautical Laboratory,
National Advisory Committee for Aeronautics,
Langley Field, Va.

REFERENCES

1. Wenzinger, Carl J., and Harris, Thomas A.: Wind-Tunnel Investigation of an N.A.C.A. 23012 Airfoil with Various Arrangements of Slotted Flaps. NACA Rep. No. 664, 1939.
2. Wenzinger, Carl J., and Gauvain, William E.: Wind-Tunnel Investigation of an N.A.C.A. 23012 Airfoil with a Slotted Flap and Three Types of Auxiliary Flap. NACA Rep. No. 679, 1939.
3. Harris, Thomas A.: Wind-Tunnel Investigation of an N.A.C.A. 23012 Airfoil with Two Arrangements of a Wide-Chord Slotted Flap. NACA TN No. 715, 1939.
4. Wenzinger, Carl J., and Harris, Thomas A.: Wind-Tunnel Investigation of an N.A.C.A. 23021 Airfoil with Various Arrangements of Slotted Flaps. NACA Rep. No. 677, 1939.
5. Duschik, Frank: Wind-Tunnel Investigation of an N.A.C.A. 23021 Airfoil with Two Arrangements of a 40-Percent-Chord Slotted Flap. NACA TN No. 728, 1939.
6. Recant, I. G.: Wind-Tunnel Investigation of an N.A.C.A. 23030 Airfoil with Various Arrangements of Slotted Flaps. NACA TN No. 755, 1940.
7. Wenzinger, Carl J., and Harris, Thomas A.: Wind-Tunnel Investigation of N.A.C.A. 23012, 23021, and 23030 Airfoils with Various Sizes of Split Flap. NACA Rep. No. 668, 1939.

12

8. Wenzinger, Carl J., and Delano, James B.: Pressure Distribution over an N.A.C.A. 23012 Airfoil with a Slotted and a Plain Flap, NACA Rep. No. 633, 1938.
9. Harris, T. A., and Lowry, J. G.: Pressure Distribution over an NACA 23021 Airfoil with a Slotted and a Split Flap. NACA Rep. No. 718, 1941.
10. Wenzinger, Carl J., and Anderson, Walter B.: Pressure Distribution over Airfoils with Fowler Flaps. NACA Rep. No. 620, 1938.
11. Harris, Thomas A.: The 7 by 10 Foot Wind Tunnel of the National Advisory Committee for Aeronautics. NACA Rep. No. 412, 1931.
12. Jacobs, Eastman W., and Sherman, Albert: Airfoil Section Characteristics as Affected by Variations of the Reynolds Number. NACA Rep. No. 586, 1937.
13. Wenzinger, Carl J.: Wind-Tunnel Tests of a Clark Y Wing Having Split Flaps with Gaps. NACA TN No. 650, 1938.
14. Wenzinger, Carl J., and Harris, Thomas A.: Preliminary Wind-Tunnel Investigation of an N.A.C.A. 23012 Airfoil with Various Arrangements of Venetian-Blind Flaps. NACA Rep. No. 689, 1940.

TABLE I

Ordinates for Airfoil and Flap Shapes

NACA 23012 airfoil (stations and ordinates in percent wing chord)			Clark Y flaps (stations and ordinates in percent flap chord)		
Station	Upper surface	Lower surface	Station	Upper surface	Lower surface
0	-	0	0	3.50	3.50
1.25	2.67	-1.23	1.25	5.45	1.93
2.5	3.61	-1.71	2.5	6.50	1.47
5.0	4.91	-2.26	5.0	7.90	.93
7.5	5.90	-2.61	7.5	8.85	.63
10	6.43	-2.92	10	9.60	.42
15	7.19	-3.50	15	10.69	.15
20	7.50	-3.97	20	11.36	.03
25	7.60	-4.28	30	11.70	0
30	7.55	-4.46	40	11.40	0
40	7.14	-4.48	50	10.52	0
50	6.41	-4.17	60	9.15	0
60	5.47	-3.67	70	7.35	0
70	4.36	-3.00	80	5.22	0
80	3.08	-2.16	90	2.80	0
90	1.68	-1.23	95	1.49	0
95	.92	-.70	100	.12	0
100	.13	-.13			
L.E. radius: 1.58. Slope of radius through end of chord: 0.305.			L.E. radius: 1.50		

NACA

Figs. 1,2.

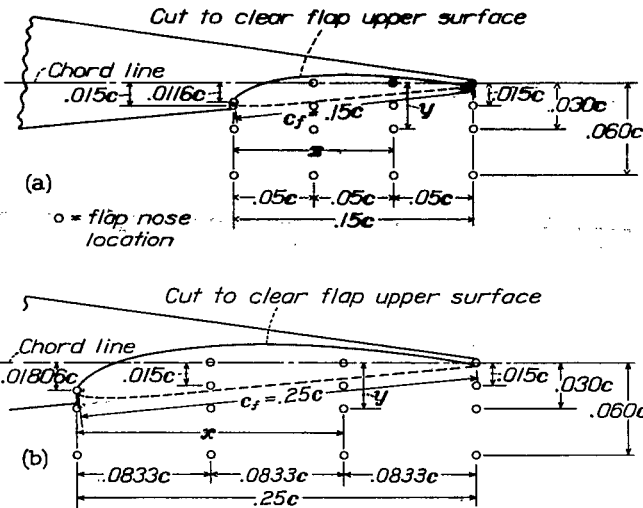

Figure 1.- The 0.15c and the 0.25c balanced split Clark Y flaps on the NACA 23012 airfoil showing the various flap-nose locations tested.

- (a) The 0.15c balanced split flap.
- (b) The 0.25c balanced split flap.

All dimensions are given in terms of wing chord, c .

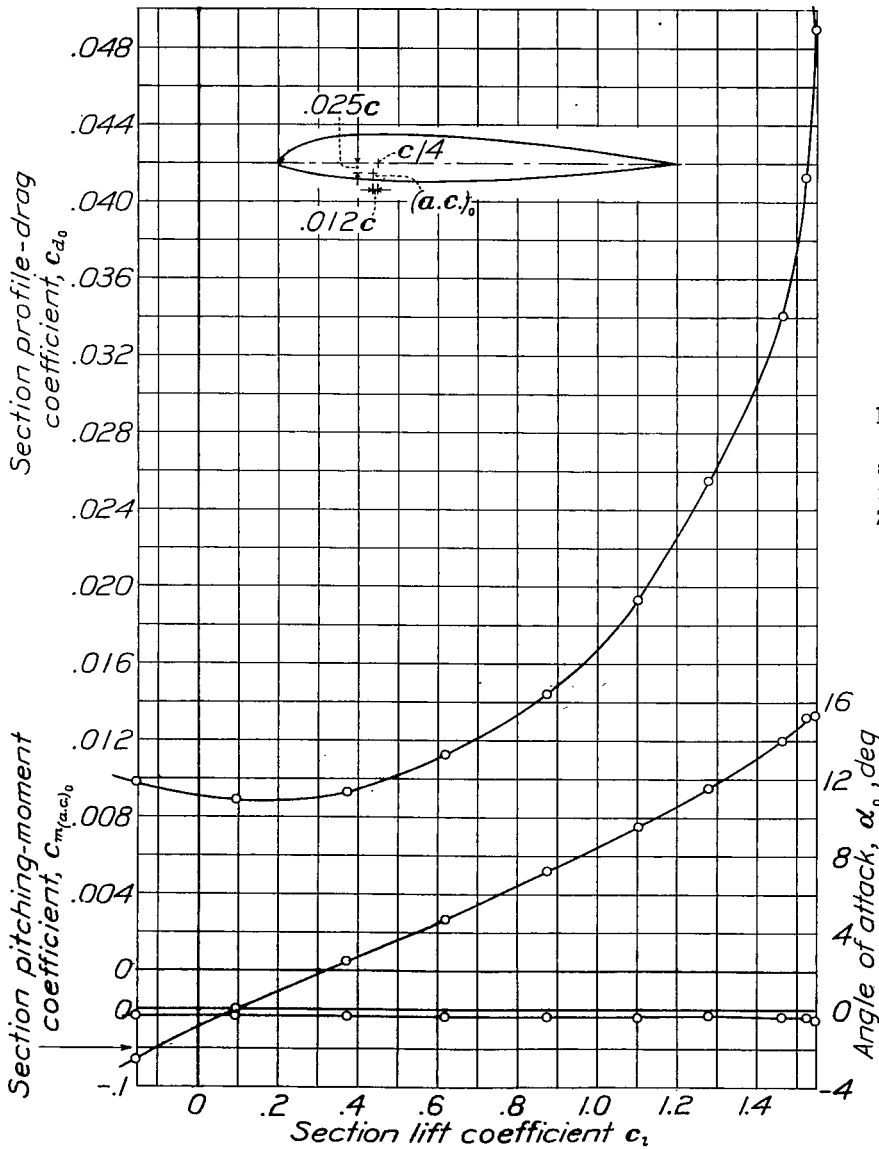

Figure 2.- Aerodynamic section characteristics of the NACA 23012 plain airfoil.

NACA

Fig. 3.

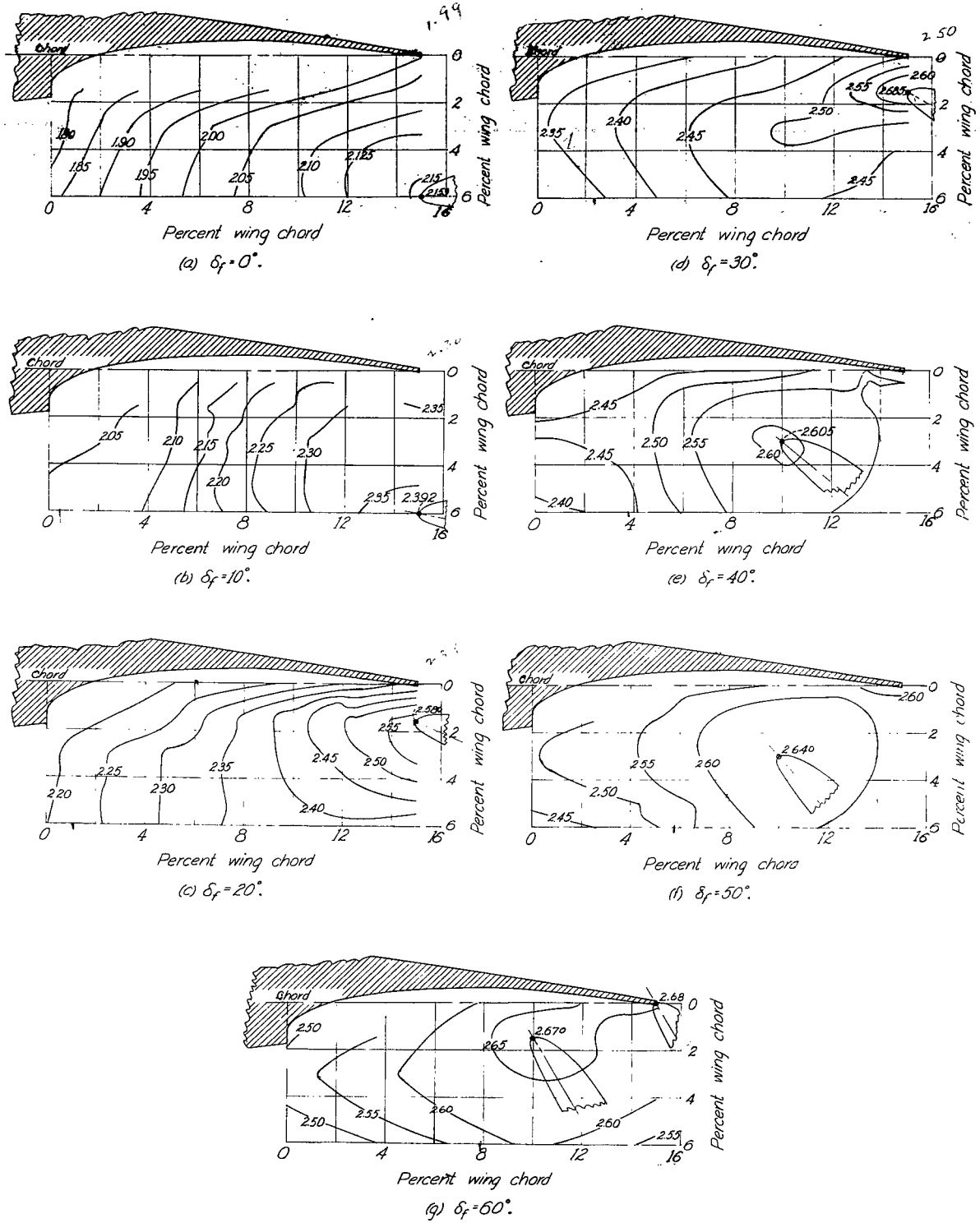

Figure 3. -Contours of flap location for $C_{l,max}$
 The 0.15c balanced split Clark Y flap

NACA

Fig 4

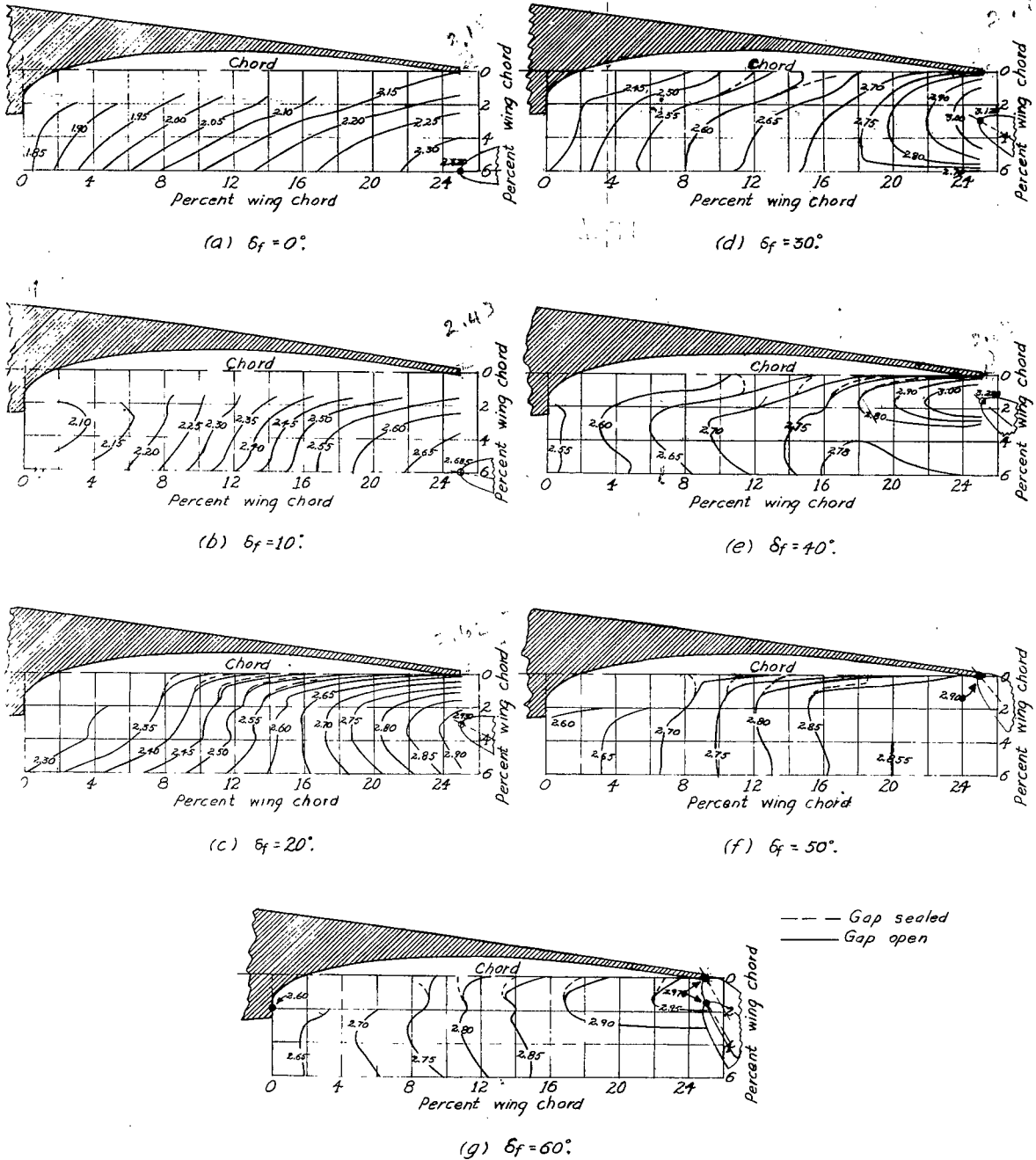
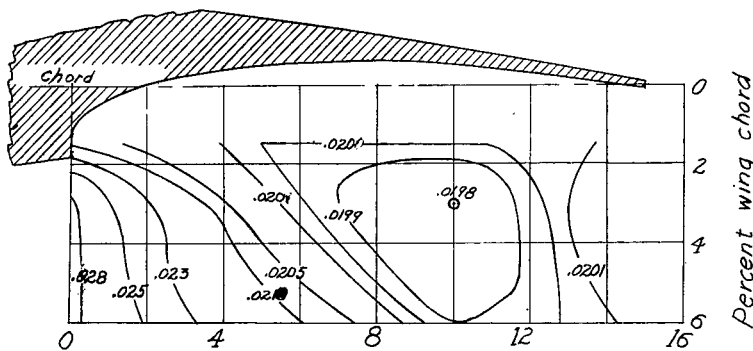
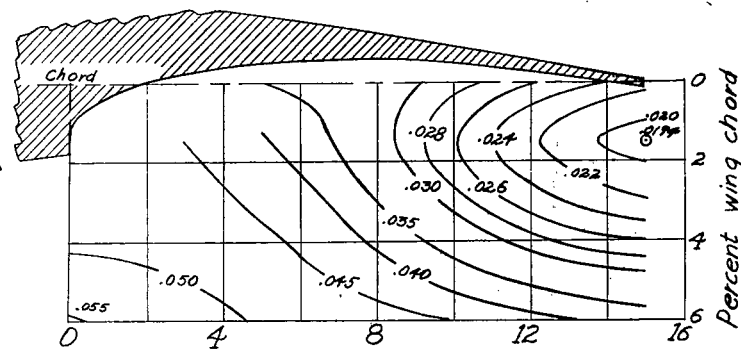

Figure 4. - Contours of flap location for C_{2max} .
 The 0.25c balanced split Clark Y flap.



(a) $\delta_f = 0^\circ$



(c) $\delta_f = 20^\circ$

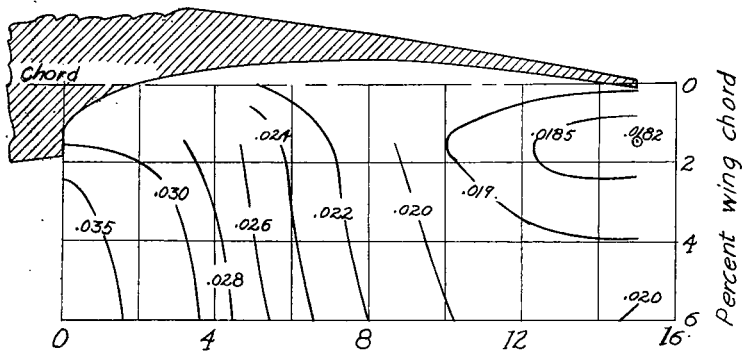

(b) $\delta_f = 10^\circ$

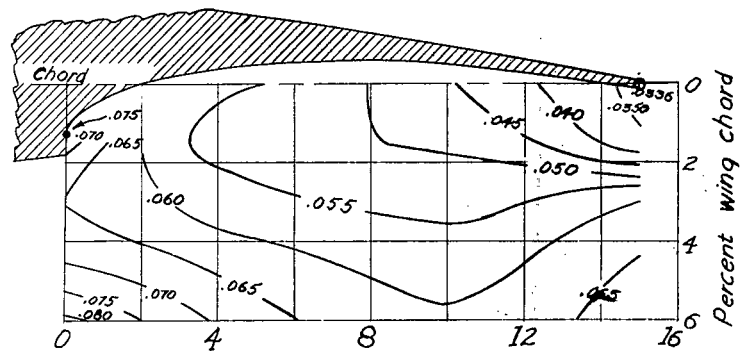

(d) $\delta_f = 30^\circ$

Figure 5. -Contours of flap location for c_{d_0} .
 The 0.15c balanced split Clark Y flap. $c_f = 1.0$.

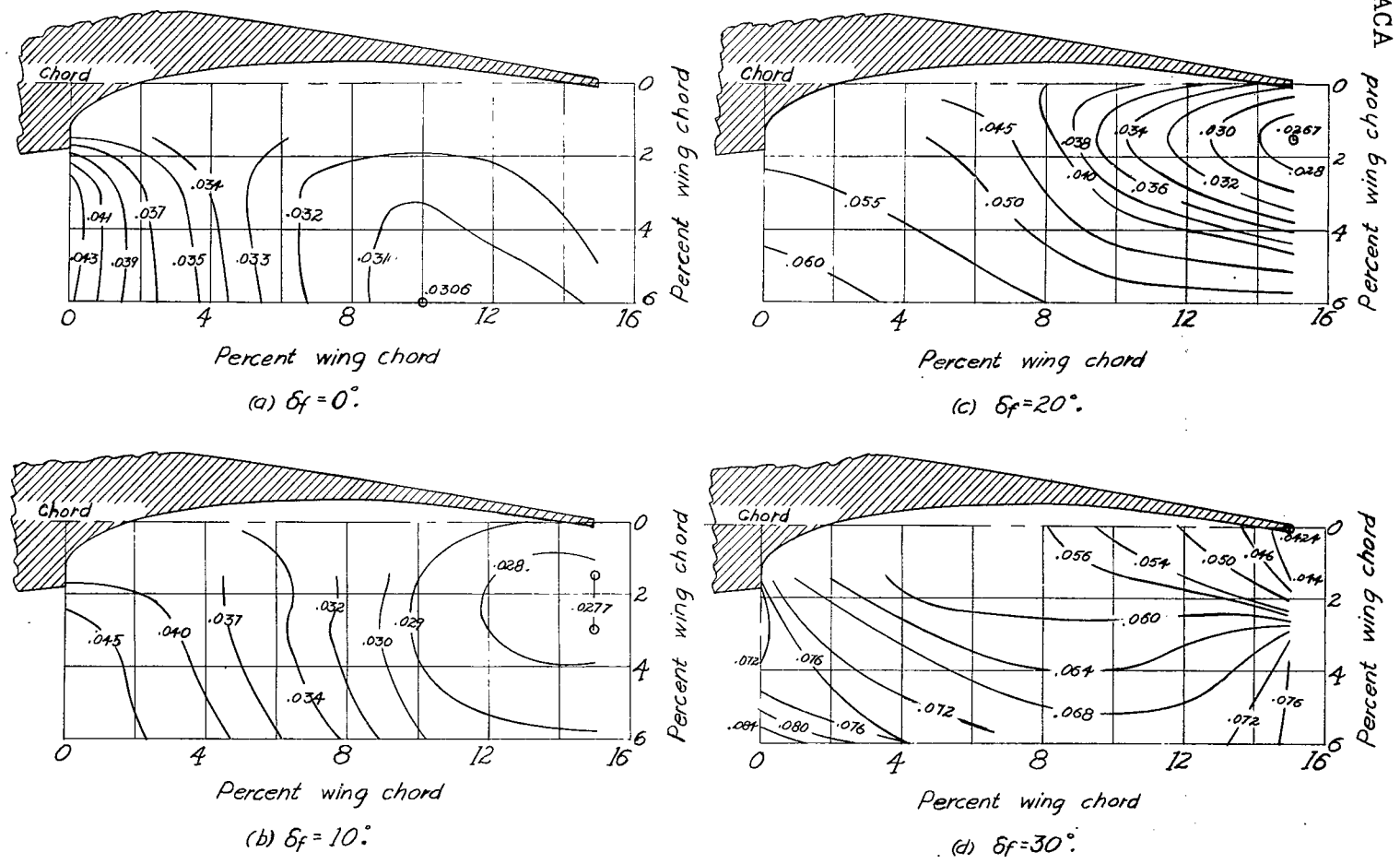

NACA

Percent wing chord

Figure 6. -Contours of flap location for c_{d_0} .
 The 0.15c balanced split Clark Y flap. $c_f = 1.5$.

FIG. 6.

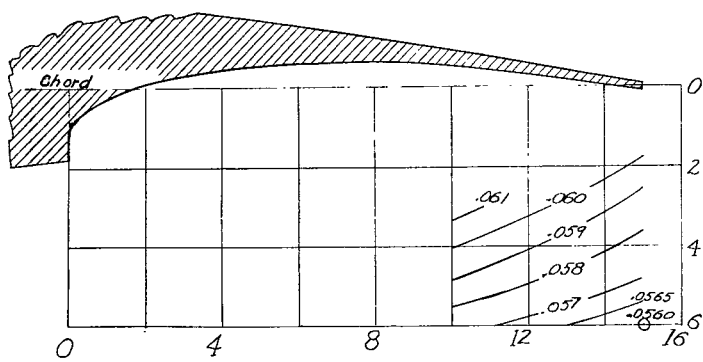

(a) $\delta_f = 0^\circ$

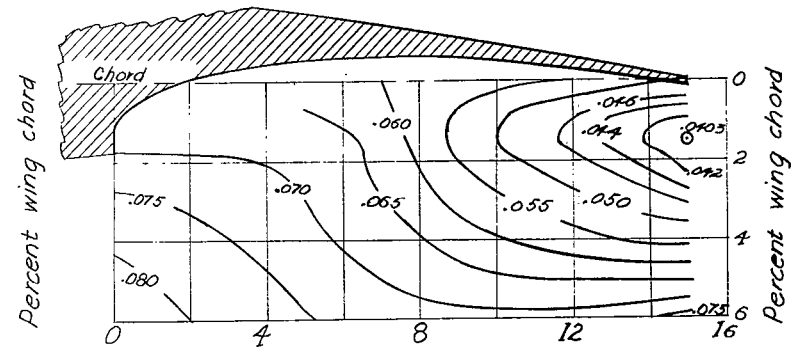

(c) $\delta_f = 20^\circ$

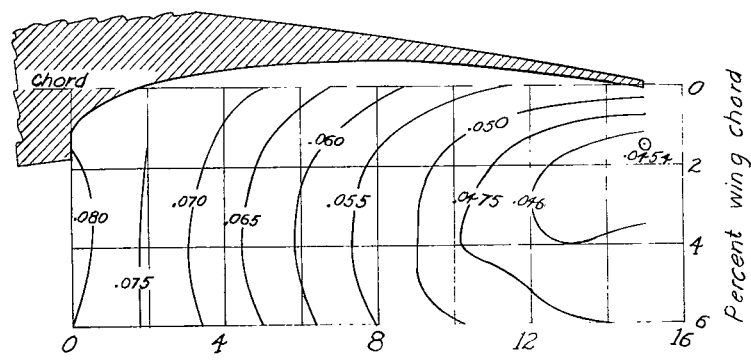

(b) $\delta_f = 10^\circ$

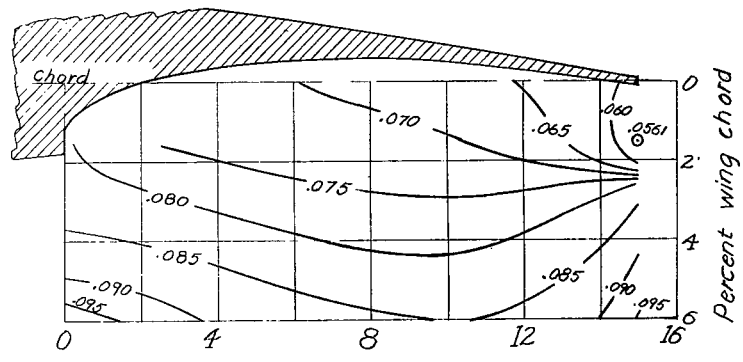

(d) $\delta_f = 30^\circ$

Figure 7. -Contours of flap location for c_{d_0} :
 The 0.15c balanced split Clark Y flap. $c_2 = 2.0$.

at. 78. 87. 7-15-40

NACA

Fig. 8.

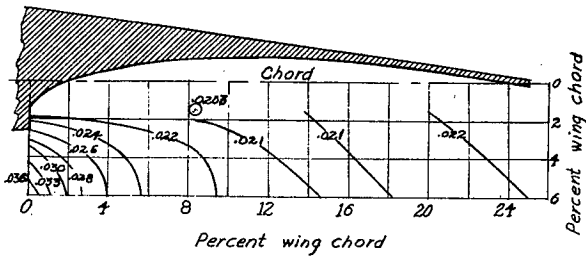

(a) $\delta_f = 0^\circ$

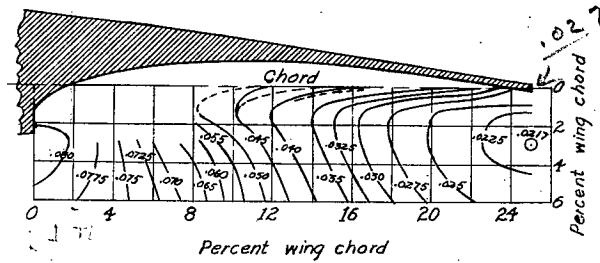

(c) $\delta_f = 20^\circ$

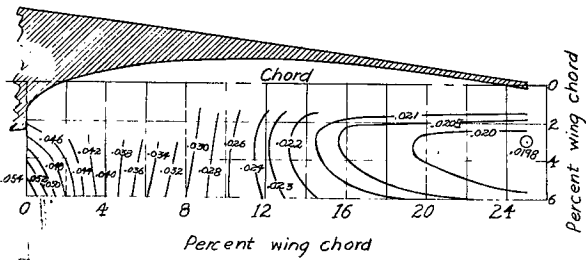

(b) $\delta_f = 10^\circ$

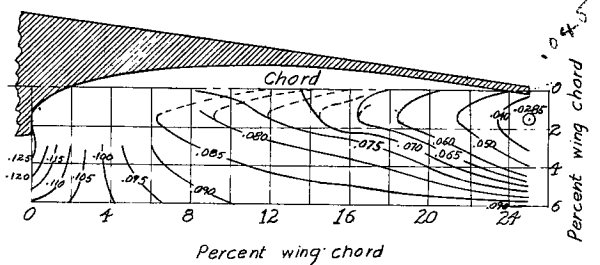

(d) $\delta_f = 30^\circ$

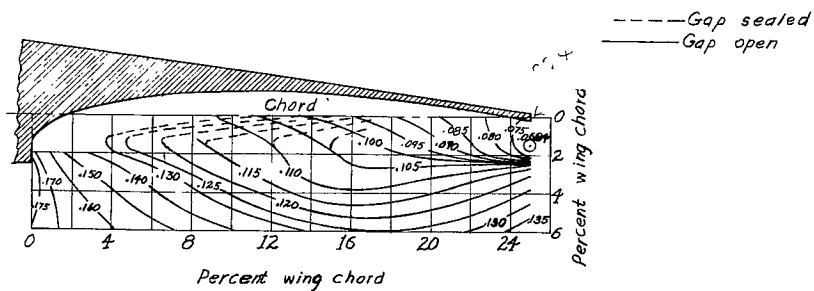

(e) $\delta_f = 40^\circ$

Figure 8. - Contours of flap location for c_{d0} :
 The Q25c balanced split Clark Y flap. $c_f = 1.0$.

NACA

Fig 9.

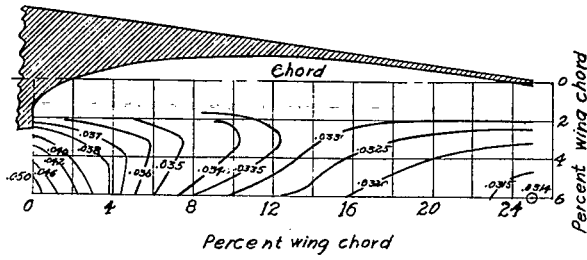

(a) $\delta_f = 0^\circ$.

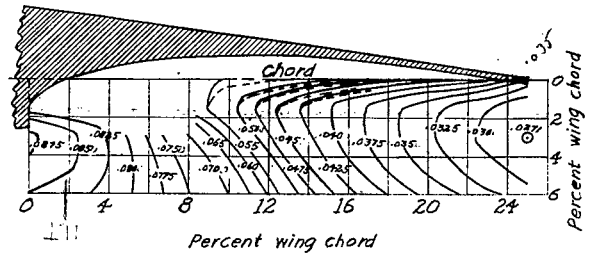

(c) $\delta_f = 20^\circ$.

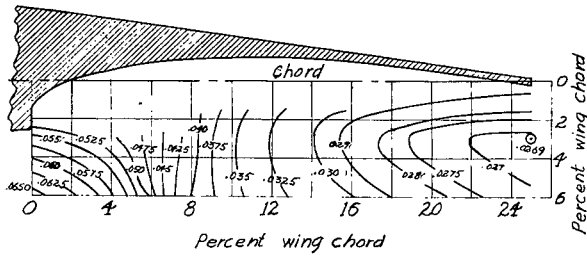

(b) $\delta_f = 10^\circ$.

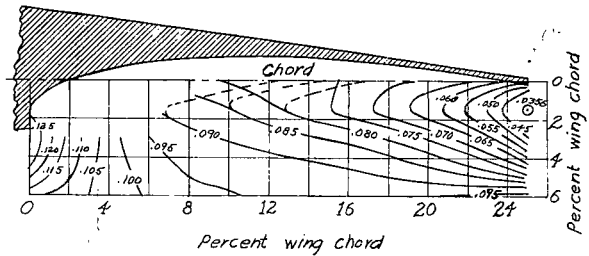

(d) $\delta_f = 30^\circ$.

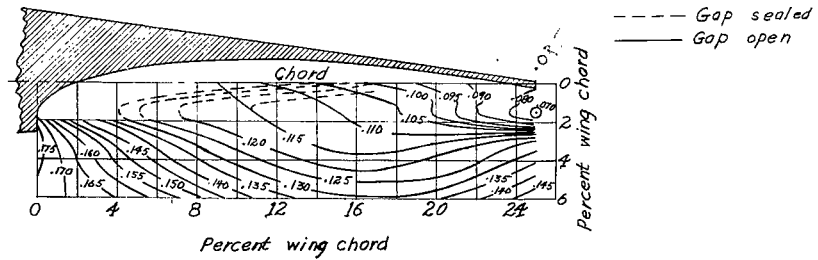

(e) $\delta_f = 40^\circ$.

Figure 9. - Contours of flap location for $c_{d\alpha}$.
 The 0.25c balanced split Clark Y flap. $c_f = 1.5$.

NACA

Figs. 10, 11.

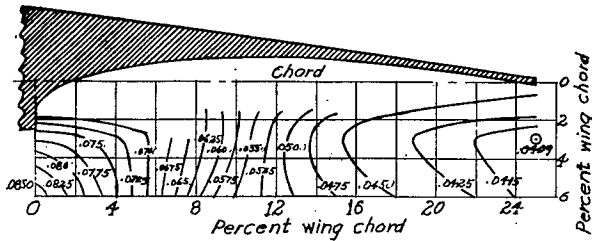

(a) $\delta_f = 10^\circ$

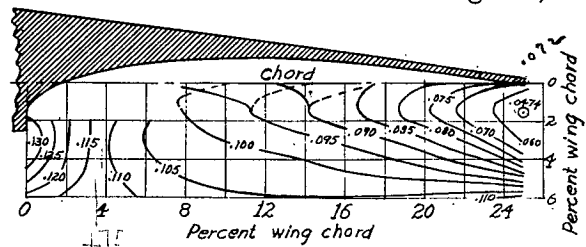

(c) $\delta_f = 30^\circ$

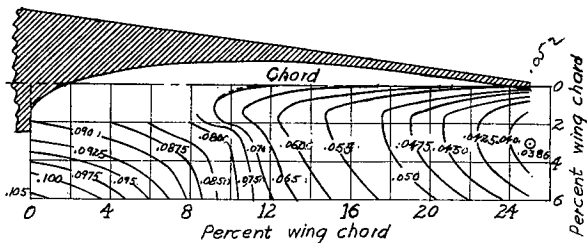

(b) $\delta_f = 20^\circ$

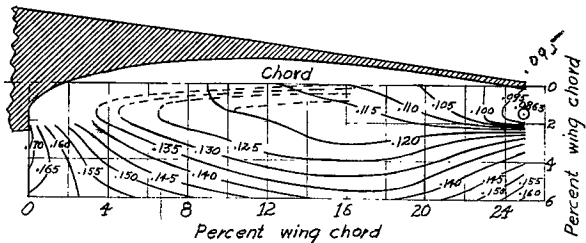

(d) $\delta_f = 40^\circ$

Figure 10. - Contours of flap location for $C_{d\beta}$.
 The 0.25c balanced split Clark Y flap. $C_f = 2.0$.

--- Gap sealed
 — Gap open

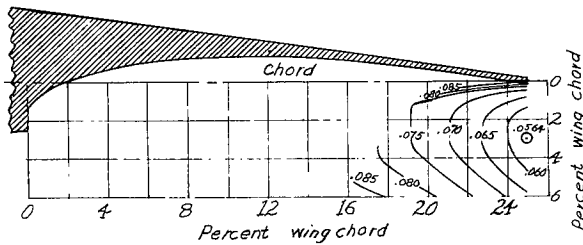

(a) $\delta_f = 20^\circ$

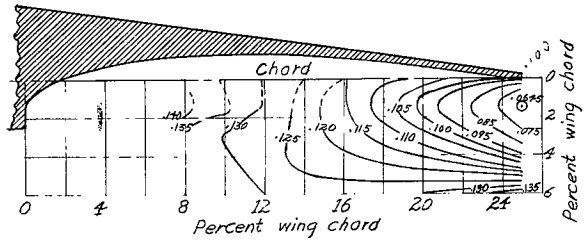

(b) $\delta_f = 30^\circ$

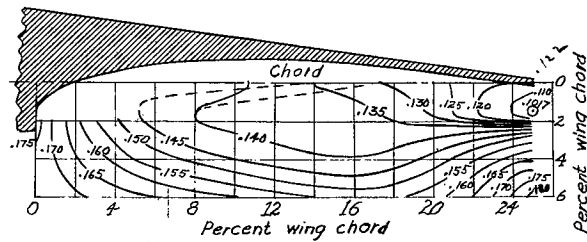

(c) $\delta_f = 40^\circ$

--- Gap sealed
 — Gap open

Figure 11. - Contours of flap location for $C_{d\beta}$.
 The 0.25c balanced split Clark Y flap. $C_f = 2.5$.

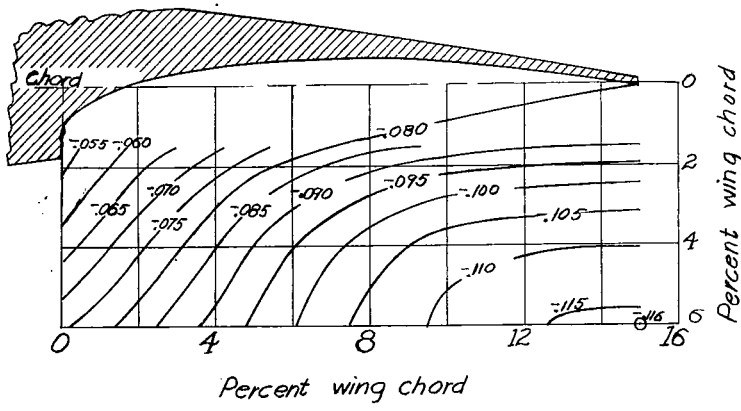

(a) $\delta_f = 0^\circ$

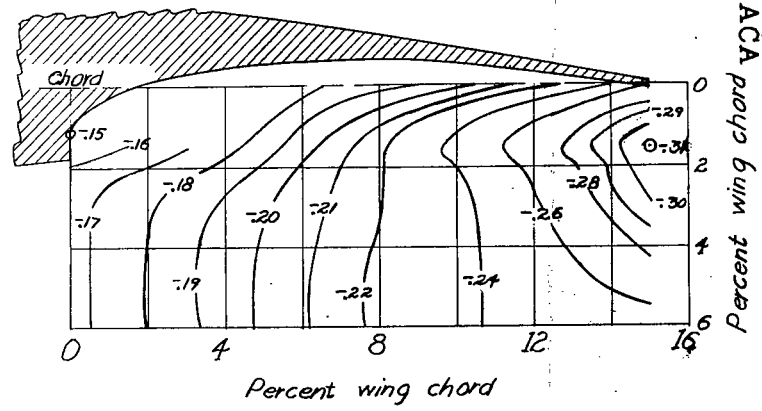

(c) $\delta_f = 20^\circ$

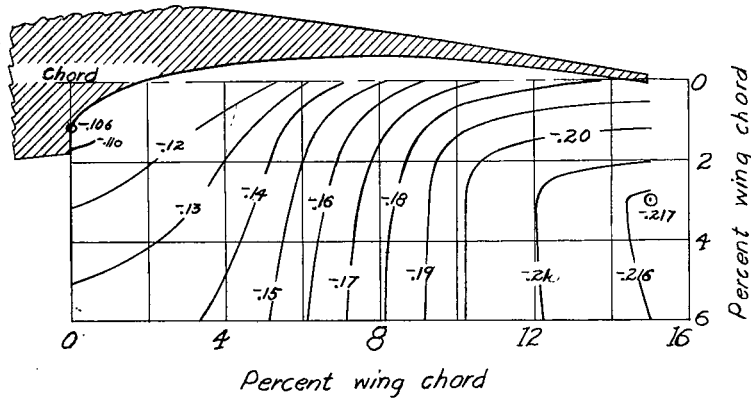

(b) $\delta_f = 10^\circ$

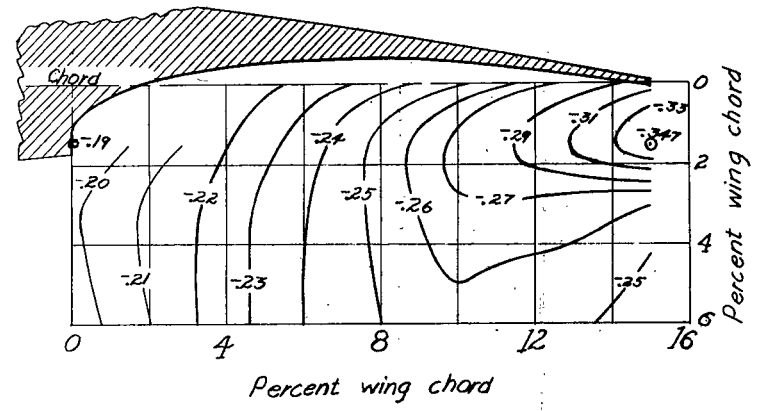

(d) $\delta_f = 30^\circ$

Figure 12. -Contours of flap location for c_m (a.c.)
 The 0.15c balanced split Clark Y flap. $\zeta = 1.0$.

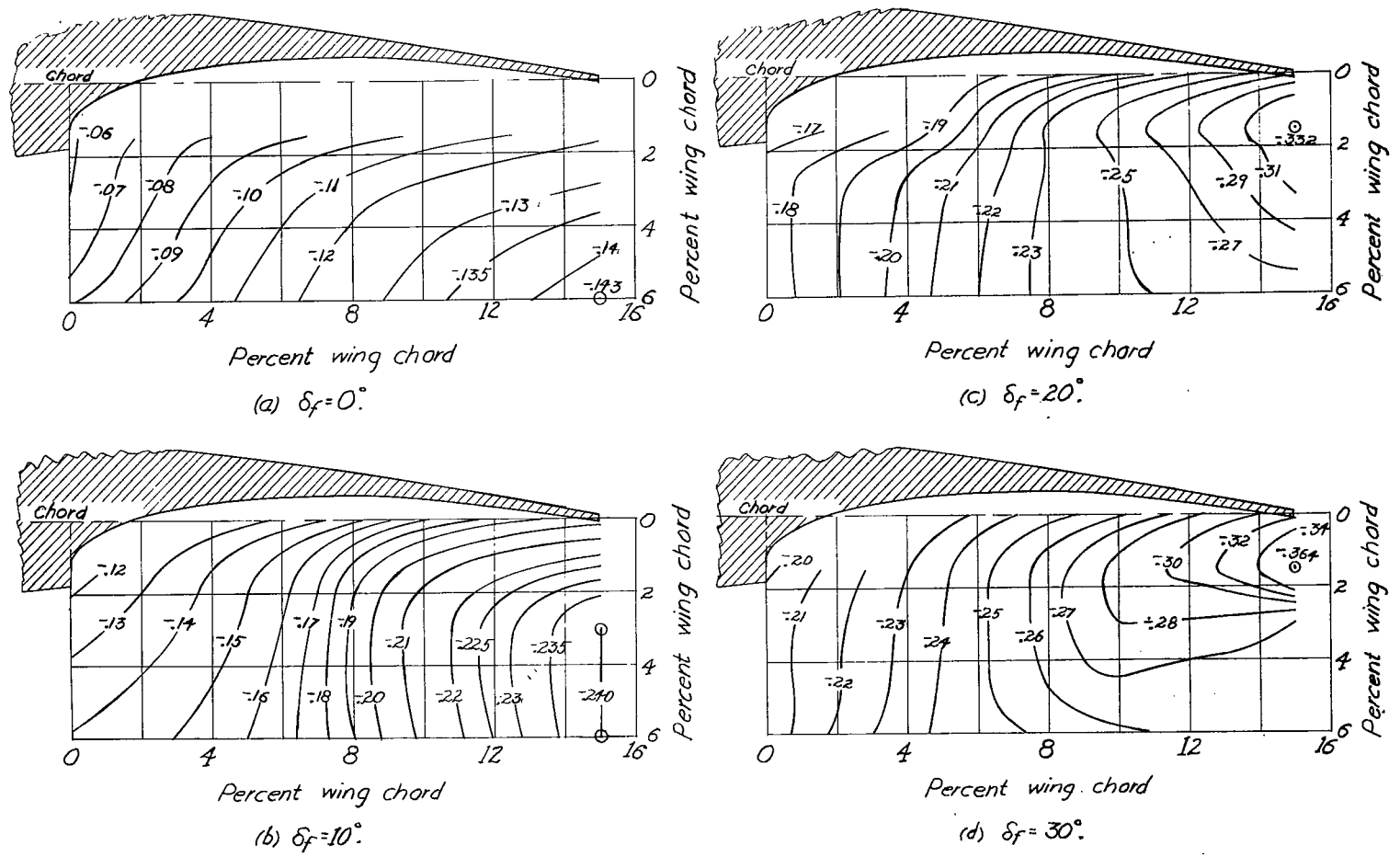

Figure 13. -Contours of flap location for $c_{m(a.c.)_0}$
 The 0.15c balanced split Clark Y flap. $c_l = 1.5$.

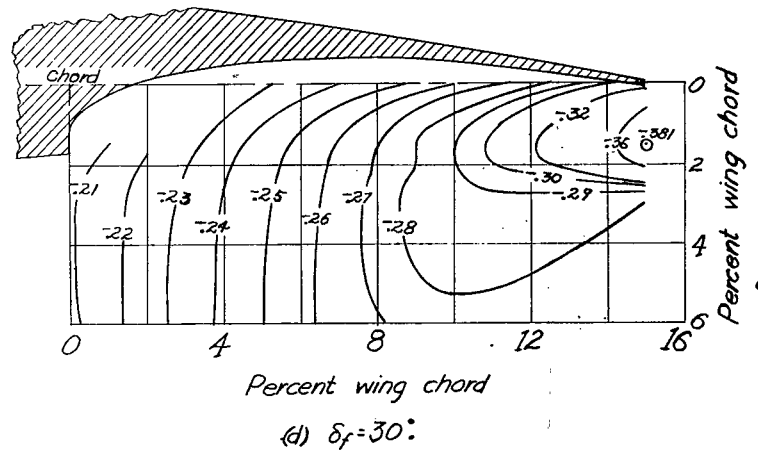
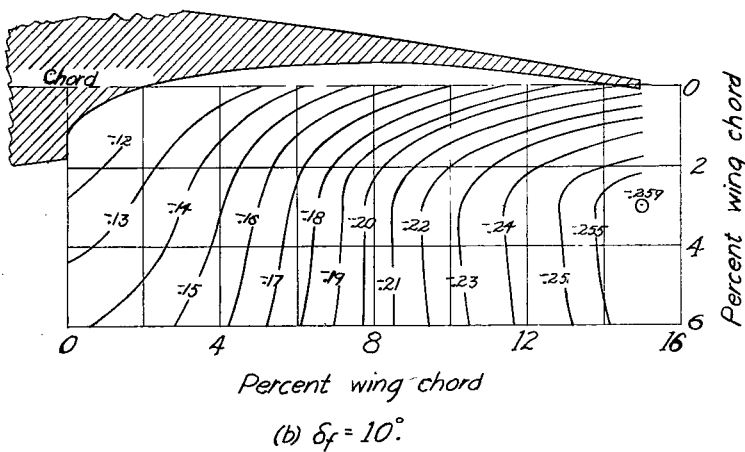
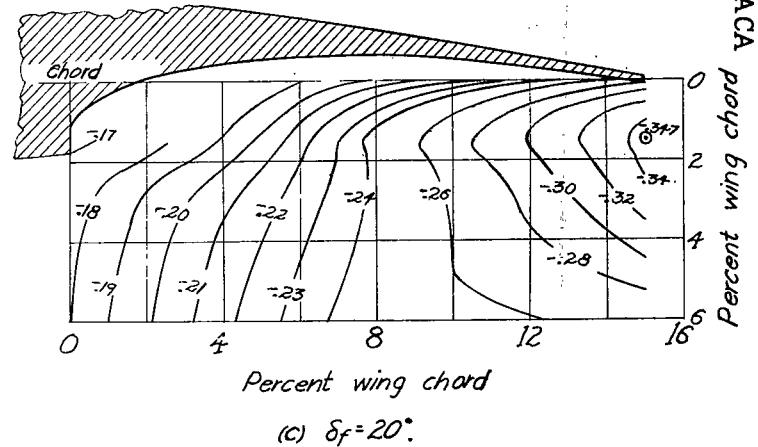
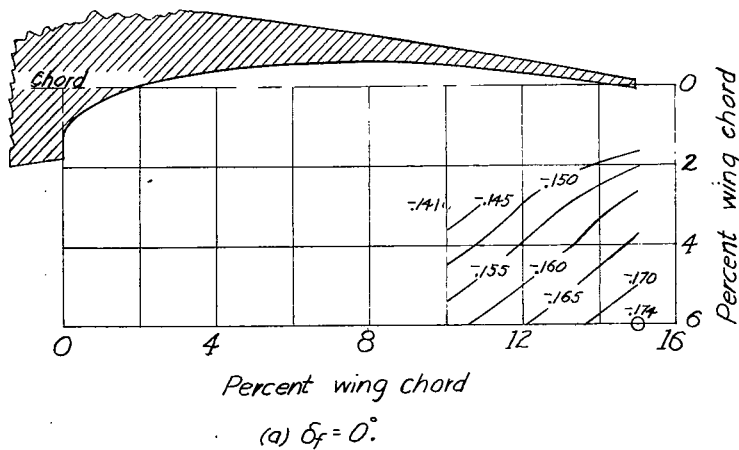
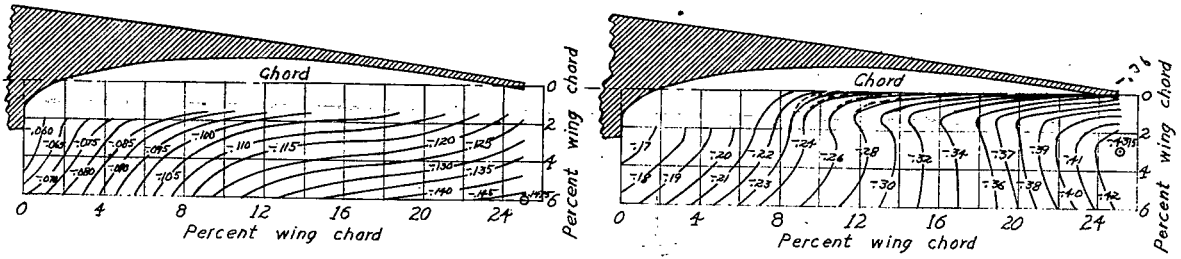

Figure 14. -Contours of flap location for $C_{m, (a.c.)_0}$
 The 0.15c balanced split Clark Y flap. $c_z = 2.0$.

NACA

Fig. 15.



(a) $\delta f = 0^\circ$

(c) $\delta f = 20^\circ$

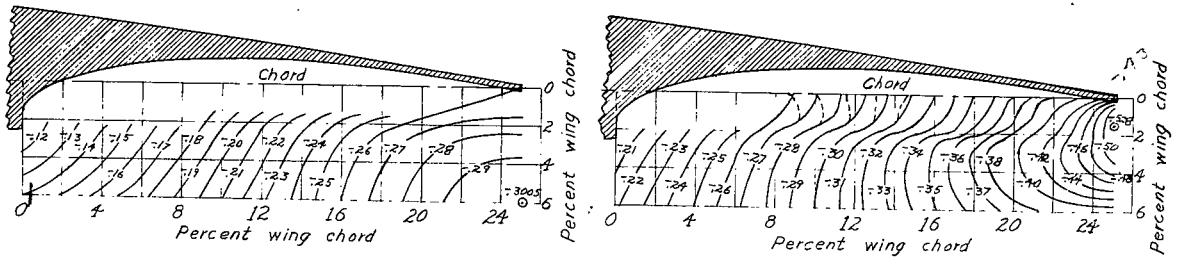

(b) $\delta f = 10^\circ$

(d) $\delta f = 30^\circ$

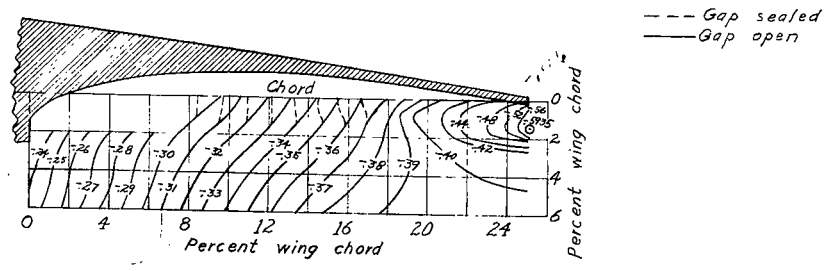

(e) $\delta f = 40^\circ$

Figure 15. - Contours of flap location for $c_{m(a.c.)}$.
 The 0.25c balanced split Clark Y flap. $c_2 = 1.0$.

NACA

Fig. 16.

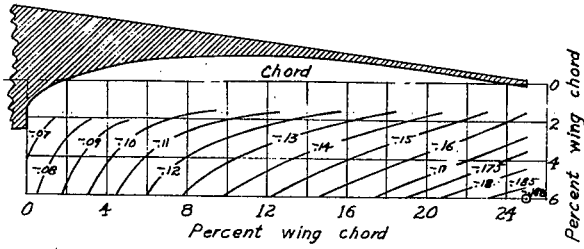

(a) $\delta f = 0^\circ$.

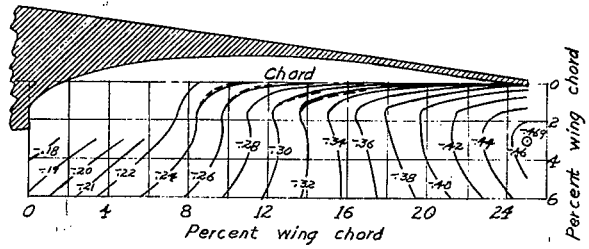

(c) $\delta f = 20^\circ$.

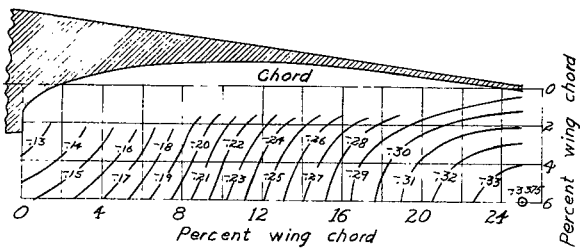

(b) $\delta f = 10^\circ$.

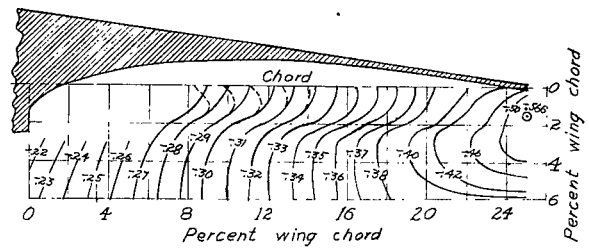

(d) $\delta f = 30^\circ$.

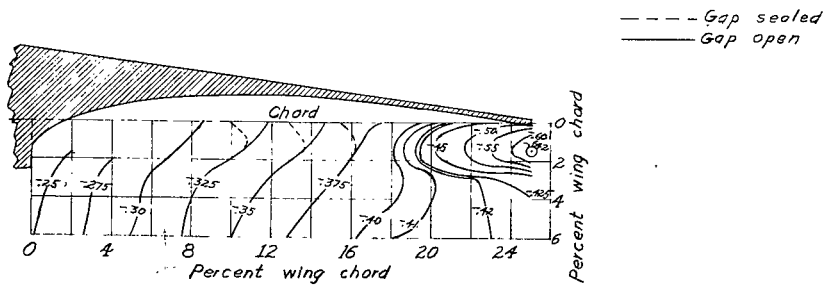

(e) $\delta f = 40^\circ$.

Figure 16. - Contours of flap location for $C_{m(a,e)}$.
 The 0.25c balanced split Clark Y flap. $C_f = 1.5$.

NACA

Figs. 17,18.

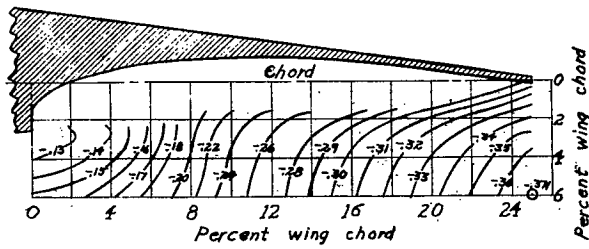

(a) $\delta f = 10^\circ$

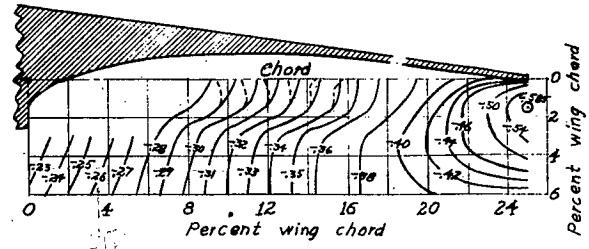

(c) $\delta f = 30^\circ$

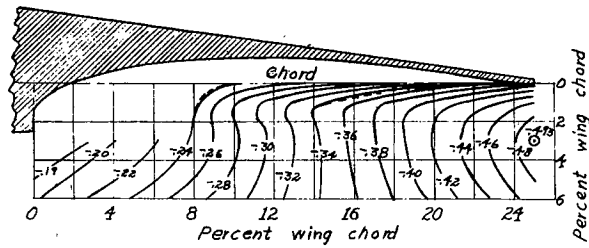

(b) $\delta f = 20^\circ$

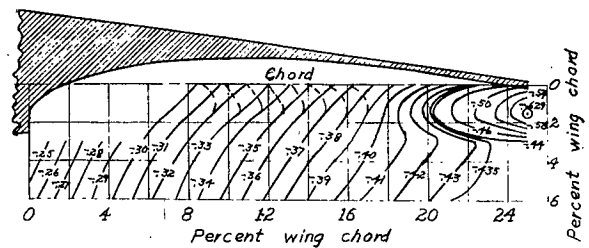

(d) $\delta f = 40^\circ$

Figure 17. - Contours of flap location for $C_{m(a,c)} = 0$.
 The 0.25c balanced split Clark Y flap. $C_f = 0$.

--- Gap sealed
 — Gap open

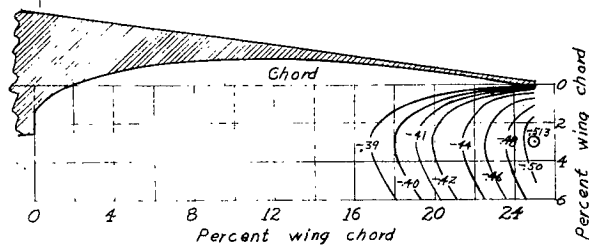

(a) $\delta f = 20^\circ$

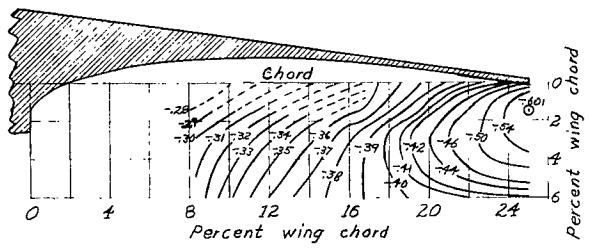

(b) $\delta f = 30^\circ$

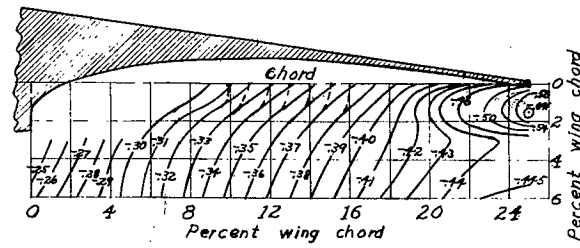

(c) $\delta f = 40^\circ$

--- Gap sealed
 — Gap open

Figure 18. - Contours of flap location for $C_{m(a,c)} = 0$.
 The 0.25c balanced split Clark Y flap. $C_f = 2.5$.

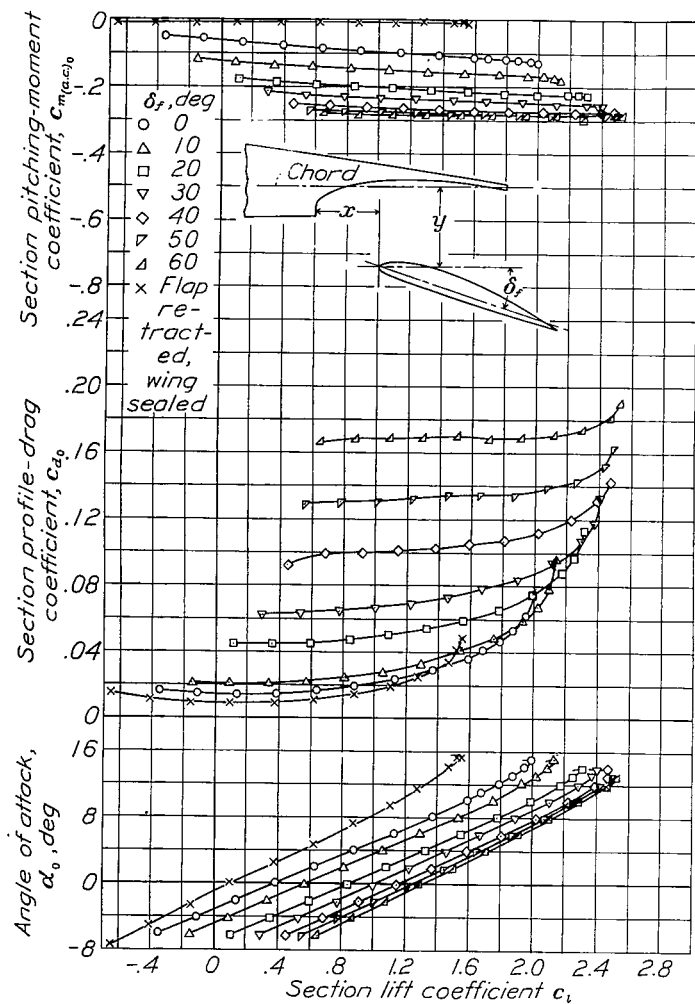

Figure 19.- Aerodynamic section characteristics. The NACA 23012 airfoil with the 0.15c balanced split Clark Y flap. $x = 0.05c$, $y = 0.06c$.

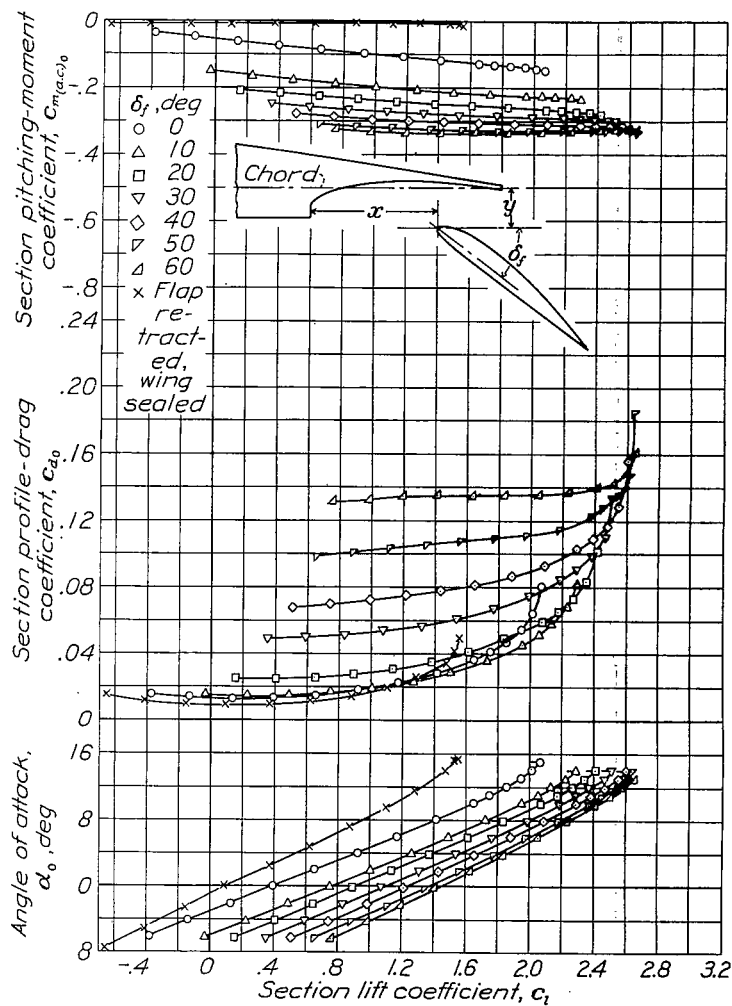

Figure 20.- Aerodynamic section characteristics. The NACA 23012 airfoil with the 0.15c balanced split Clark Y flap. $x = 0.10c$, $y = 0.03c$.

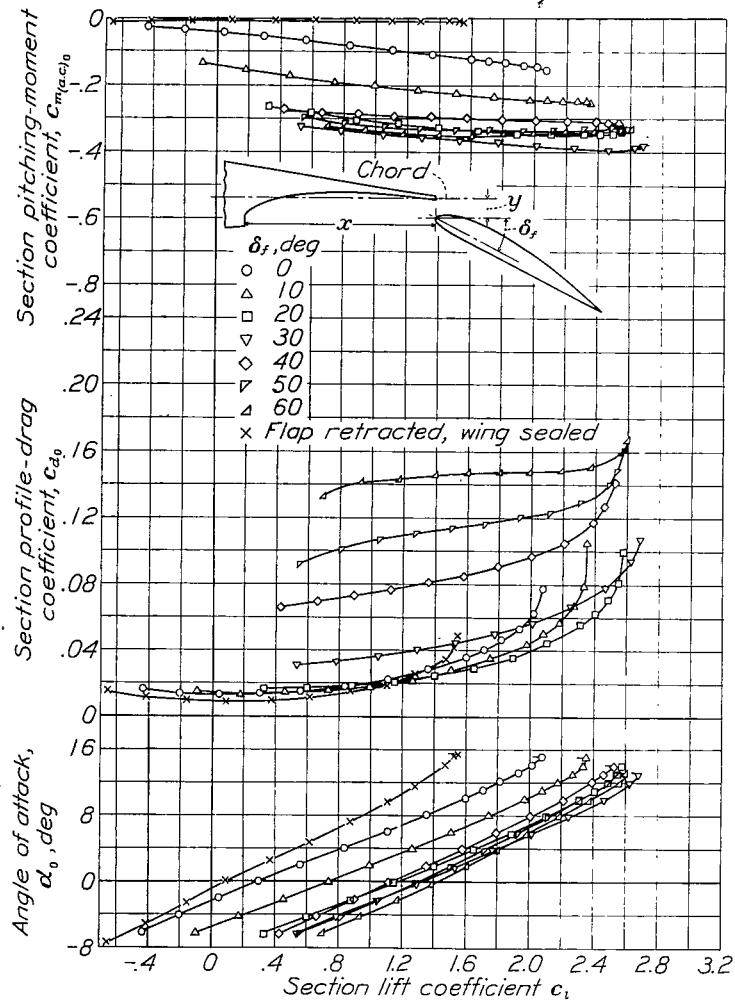

Figure 21.- Aerodynamic section characteristics. The NACA 23012 airfoil with the 0.15c balanced split Clark Y flap. $x = 0.15c$, $y = 0.015c$.

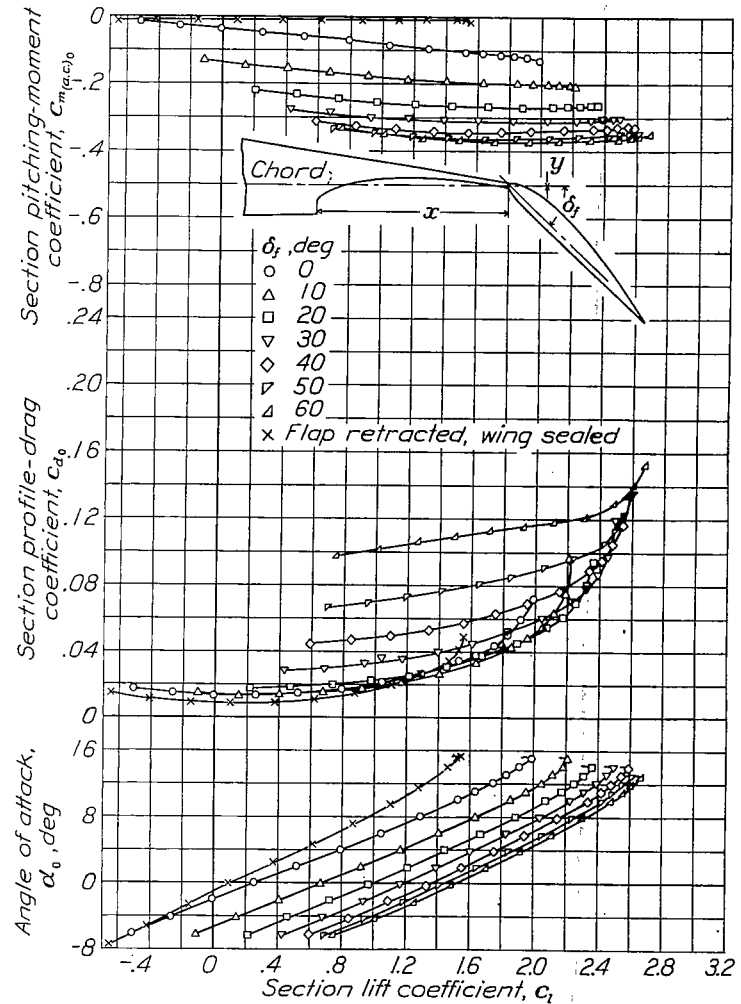

Figure 22.- Aerodynamic section characteristics. The NACA 23012 airfoil with the 0.15c balanced split Clark Y flap. $x = 0.15c$, $y = 0$.

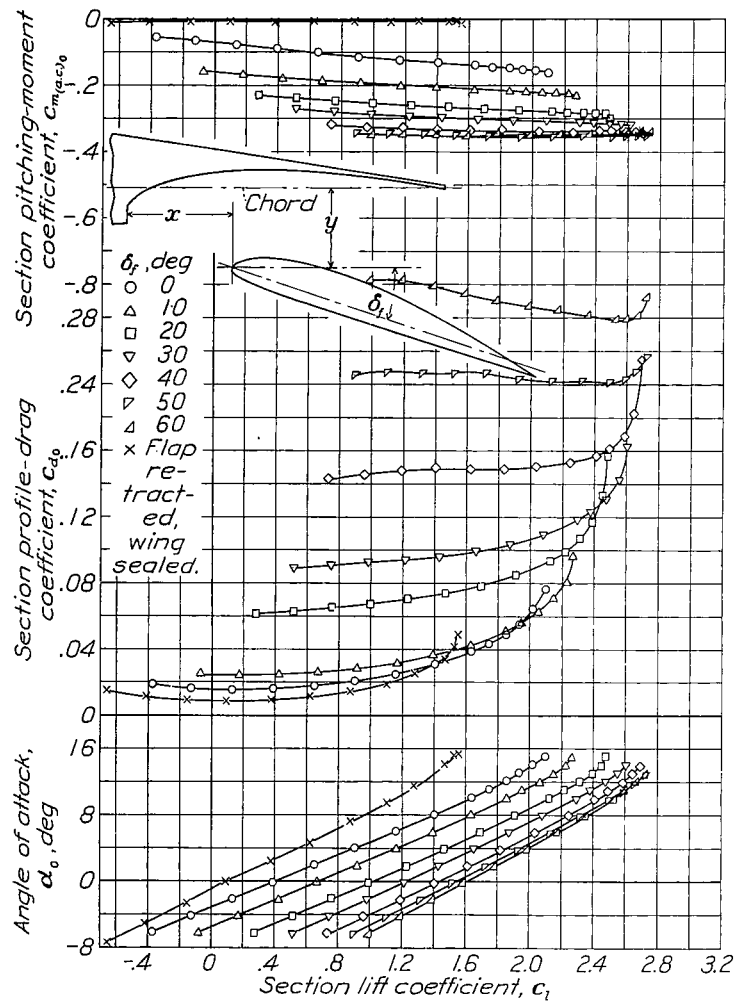

Figure 23.- Aerodynamic section characteristics. The NACA 23012 airfoil with the 0.25c balanced split Clark Y flap. $x = 0.0833c$, $y = 0.06c$.

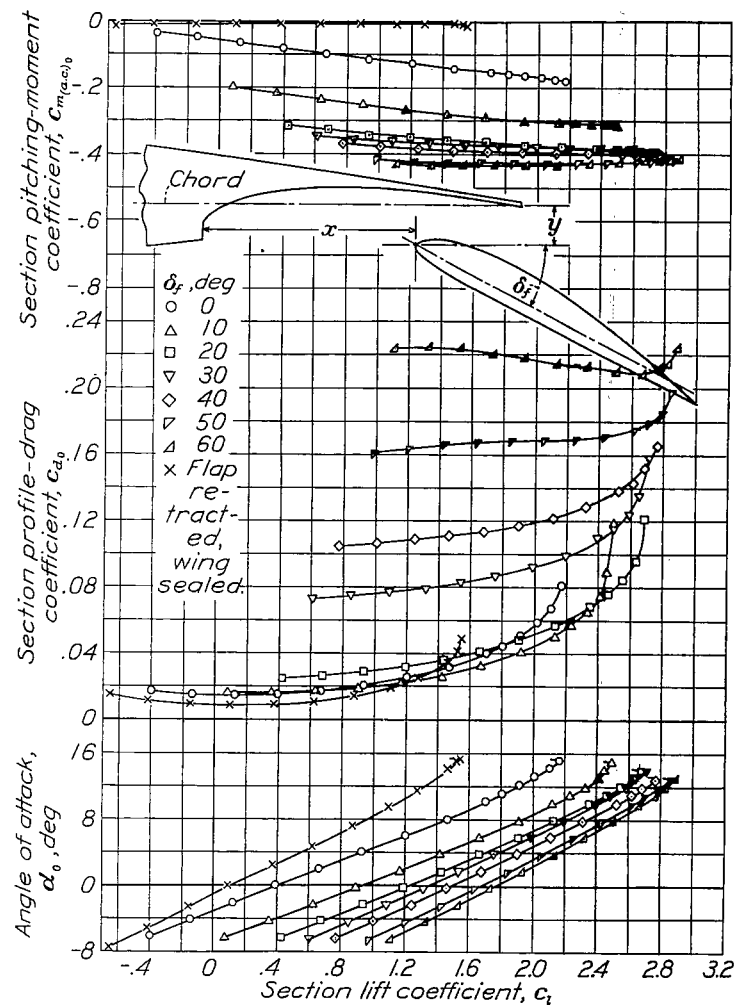

Figure 24.- Aerodynamic section characteristics. The NACA 23012 airfoil with the 0.25c balanced split Clark Y flap. $x = 0.1667c$, $y = 0.03c$.

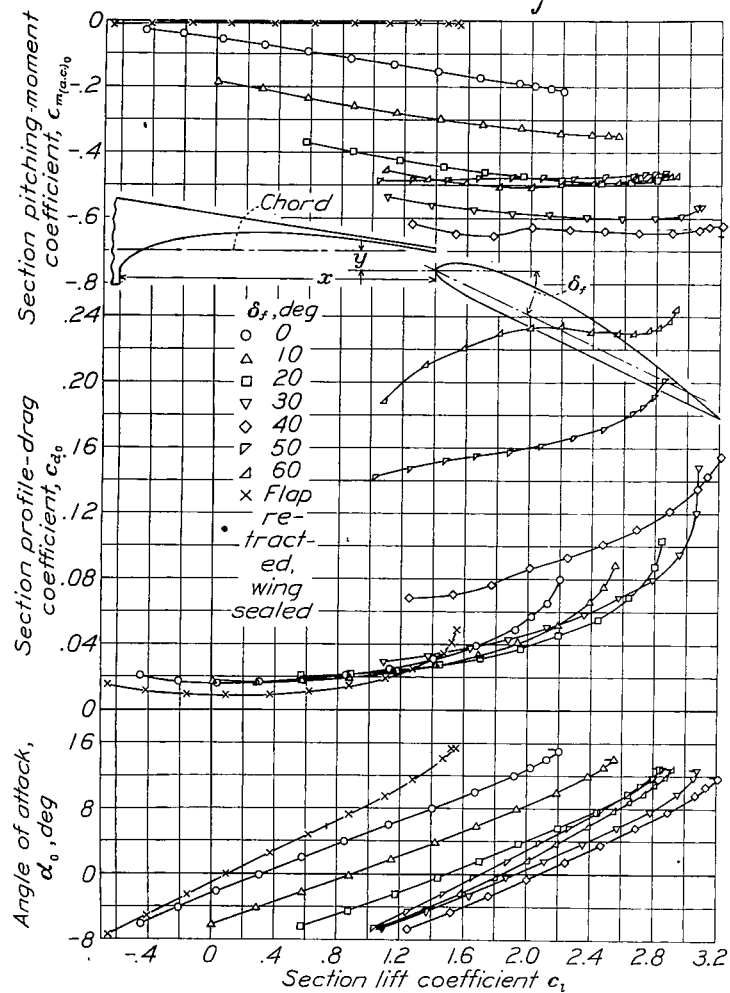

Figure 25.- Aerodynamic section characteristics. The NACA 23012 airfoil with the 0.25c balanced split Clark Y flap. $x = 0.25c$, $y = 0.015c$.

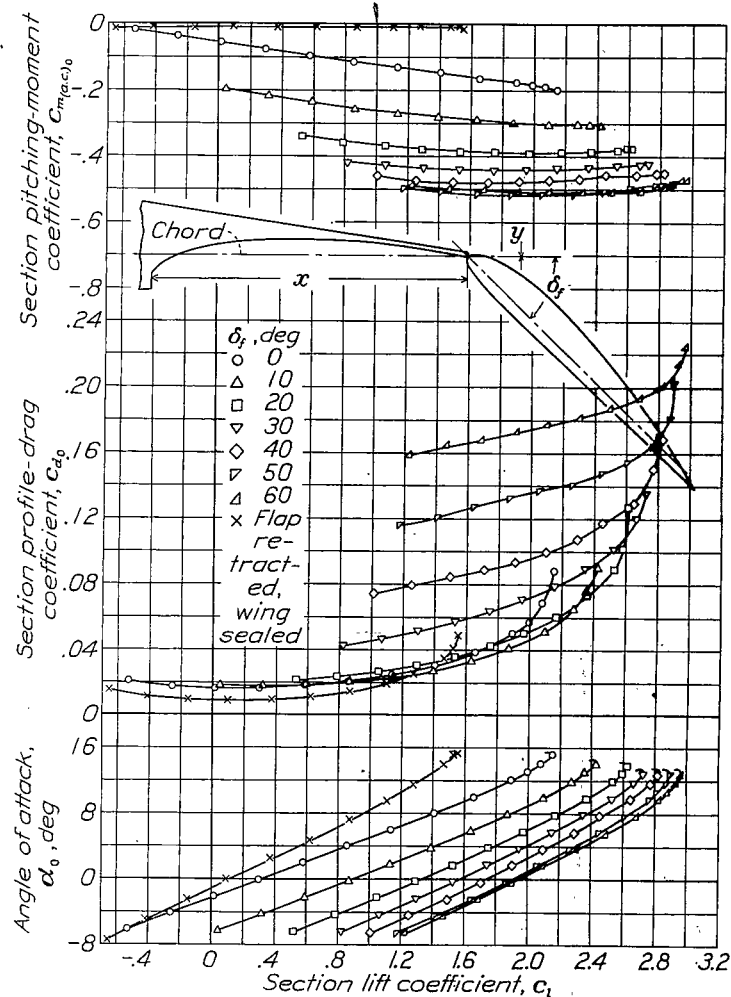

Figure 26.- Aerodynamic section characteristics. The NACA 23012 airfoil with the 0.25c balanced split Clark Y flap. $x = 0.25c$, $y = 0$.

Figure 27.- Comparison of profile-drag coefficients.
 The 0.15c balanced split Clark Y flap.

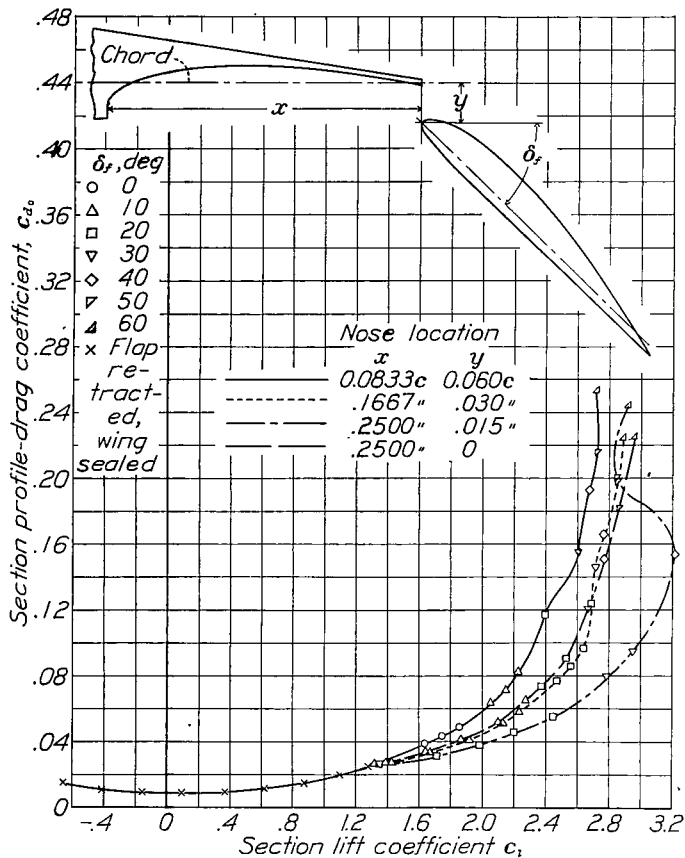

Figure 28.- Comparison of profile-drag coefficients.
 The 0.25c balanced split Clark Y flap.

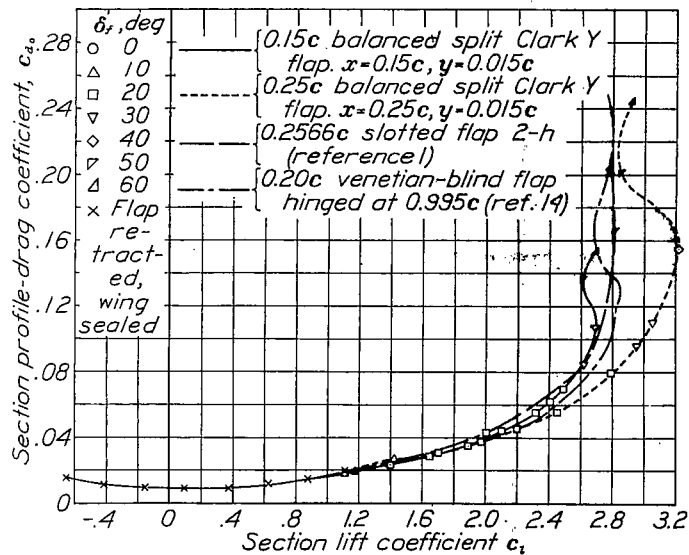
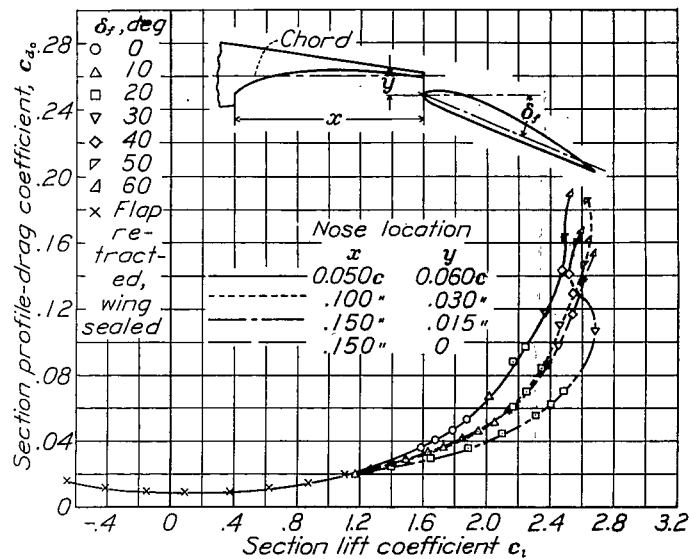



Figure 29.- Comparison of four flap arrangements on
 NACA 23012 airfoil.

LANGLEY RESEARCH CENTER

3 1176 01365 5247