

1N-24
31043
103

Basic Mechanics of Laminated Composite Plates

A.T. Nettles

(NASA-RP-1351) BASIC MECHANICS OF
LAMINATED COMPOSITE PLATES (NASA,
Marshall Space Flight Center)
103 p

N95-15763

Unclass

H1/24 0031043



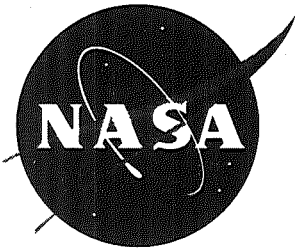

Basic Mechanics of Laminated Composite Plates

A.T. Nettles
Marshall Space Flight Center • MSFC, Alabama

National Aeronautics and Space Administration
Marshall Space Flight Center • MSFC, Alabama 35812

October 1994

TABLE OF CONTENTS

	Page
I. INTRODUCTION	1
A. Intent and Scope	1
B. Terminology and Notation	1
C. Summary of Sections	2
II. GENERALIZED HOOKE'S LAW FOR NONISOTROPIC MATERIALS	3
A. Normal Stress and Strain, Uniaxially Applied Force	3
B. Stress and Strain, Plane Stress for Specially Orthotropic Plates	4
C. Stress and Strain, Plane Stress for Generally Orthotropic Plates	6
D. Invariant Stiffnesses	10
III. MECHANICS OF LAMINATED COMPOSITES	11
A. Assumptions	11
B. Definitions of Strains and Displacements	11
C. Definitions of Stress and Moment Resultants	15
D. Constitutive Equations for a Laminate	17
E. Physical Meanings of the $[A]$, $[B]$, and $[D]$ Matrices	23
IV. NOMENCLATURE FOR DEFINING STACKING SEQUENCES	25
A. Coordinate System	25
B. Nomenclature	25
V. IN-PLANE ENGINEERING CONSTANTS FOR THE LAMINATE	28
A. Orientation of the Laminate	28
B. Symmetric Laminates	28
C. Nonsymmetric Laminates	33
D. Summary	40
VI. ENVIRONMENTAL EFFECTS	43
A. Importance	43
B. Coefficients of Thermal Expansion	43
C. Moisture Effects	45
VII. STRESSES AND STRAINS WITHIN LAMINAE OF A SYMMETRIC LAMINATE	46
A. Strains Within the Laminae	46
B. Stresses Within the Laminae	50

TABLE OF CONTENTS

	Page
VIII. STRESSES AND STRAINS WITHIN LAMINAE OF AN UNSYMMETRIC LAMINATE	63
A. Difference From Symmetric Laminates	63
B. Example $(0/+45)_T$ Laminates	63
C. Determination of the Neutral Plane	72
IX. REFERENCE OF IMPORTANT EQUATIONS	89
REFERENCES	95
APPENDIX	96

LIST OF ILLUSTRATIONS

Figure	Title	Page
1.	Difference between an isotropic and an orthotropic plate	3
2.	Definition of shearing strains	5
3.	Generally orthotropic lamina	7
4.	Displacements of a plate	12
5.	Total displacements in a plate	13
6.	Definitions of plate curvatures	14
7.	Definition of stress resultant	15
8.	Direction of stress and moment resultants	17
9.	Cross section of a laminate	19
10.	Displacements in an unsymmetrical plate.....	23
11.	Coordinate system for a typical laminate.....	26
12.	Some laminate stacking sequences and their notation	27

REFERENCE PUBLICATION

BASIC MECHANICS OF LAMINATED COMPOSITE PLATES

I. INTRODUCTION

A. Intent and Scope

This report is intended only to be used as a quick reference guide on the mechanics of continuous fiber-reinforced laminates. By continuous fiber-reinforced laminates, the following is assumed:

- (1) The material to be examined is made up of one or more plies (layers), each ply consisting of fibers that are all uniformly parallel and continuous across the material. The plies do not have to be of the same thickness or the same material.
- (2) The material to be examined is in a state of plane stress, i.e., the stresses and strains in the through-the-thickness direction are ignored.
- (3) The thickness dimension is much smaller than the length and width dimensions.

An attempt is made in this report to develop a practical guide that can be easily referenced by the engineer who is not familiar with composite materials, or to aid those who have seen this subject matter before.

The scope of the report will be limited to the elastic response of the above-mentioned class of material. Strength-of-laminated composites will not be covered. General composite material mechanics and strength are developed in more detail in texts such as Jones¹ and Halpin.² It is assumed that the reader has a general knowledge of elastic stress-strain behavior.

B. Terminology and Notation

Some terminology important to composite materials follows:

Isotropic—Possessing the same mechanical properties in all directions. Composite laminates are never isotropic.

Laminate—A material consisting of layers (laminae) bonded together.

Transversely Isotropic—Possessing one plane that has the same mechanical properties at any direction in that plane, i.e., the laminate will have the same stress-strain behavior at any direction in the plane of the material (sometimes called quasi-isotropic).

Orthotropic—A material that has different mechanical properties in three mutually perpendicular planes. Note that the properties of the material are direction specific in this case. All unidirectional laminae are individually orthotropic. Most laminated composites fall into this category.

Homogeneous—Material properties do not change from point to point within the material. Since filamentary composites consist of at least two distinct phases (fiber and matrix), laminated composites are never truly homogeneous, although on a macroscopic scale when discussing the linear elastic response (no damage) of laminated composites the material may be generalized as homogeneous. This assumption is termed “smearing” of fiber and matrix. In reality all composites are heterogeneous.

Principal Material Directions—Directions parallel and perpendicular to the fibers in a lamina. Note that these directions are not necessarily the directions of principal stress as defined by continuum mechanics.

Balanced Laminate—For each $+\theta$ ply in the laminate there is an equally thick $-\theta$ ply in the laminate. This does not apply to 0° and 90° plies.

Symmetric Laminate—The plies of the laminate are a mirror image about the geometrical midplane.

Angle Ply Laminate—Containing plies oriented at angle(s) other than 0° or 90° .

The notation used throughout this report denotes the directions parallel, perpendicular, and through-the-thickness to the aligned fibers of a ply of material as 1, 2, and 3, respectively. The coordinates of the laminate are denoted by x, y (in-plane) and through-the-thickness z . Some texts and laminate analysis computer software have reverse notation, which is exactly opposite to that presented here. Some users prefer to use a primed and unprimed notation. Thus, it is important to note which notation is being used.

Since a state-of-plane stress is assumed, the term “plate” will be interchangeable with material and composite laminate. Please note that in actual practice, the laminate does not need to be a plate, but may be a shell or other shape such that the material is considered “thin.”

C. Summary of Sections

In section II, the behavior of an individual ply or lamina is considered. This behavior is the “building block” upon which laminated plate theory is based. The important concept of coupling, unique to anisotropic materials, will be introduced in this section.

The main body of this report is considered in section III. It develops the relationship between loads and deflections for a composite laminate. Most information on the elastic response of laminated composites can be calculated from the equations given in this section. The constitutive equations that govern the laminate load/deflection behavior are given in this section.

For those who have not dealt with laminates, section IV shows how stacking sequences of the plies that make up the laminate are denoted. This section simply presents a standard “code” by which a laminate can be described. Many will already be familiar with this material.

Section V contains derivations of the most sought after numbers when dealing with the elastic response of these materials, the engineering constants. Many texts on laminated composites omit this part, or only present it for special types of laminates that make the calculation relatively simple. The engineering constants for any laminate can be found from the equations in this section.

Section VI introduces the effects of temperature and moisture on the strain of a composite laminate. These effects are often neglected, but are very important in determining the stresses and strains within each ply of the laminate. Determining these ply stresses and strains for symmetric laminates is presented in section VII and in section VIII for unsymmetric laminates. These sections provide information necessary to study the strength of composite laminates.

Section IX is a summary of the most important equations presented in this paper.

II. GENERALIZED HOOKE'S LAW FOR NONISOTROPIC MATERIALS

A. Normal Stress and Strain, Uniaxially Applied Force

Normal stress is defined as the force per unit area acting perpendicular to the surface of the area. The corresponding strain is defined as the elongation (or stretch) per unit length of material in the direction of the applied force. For isotropic materials, the relationship between stress and strain is independent of the direction of force, thus only one elastic constant (Young's modulus) is required to describe the stress-strain relationship for a uniaxially applied force. For a nonisotropic material, at least two elastic constants are needed to describe the stress-strain behavior of the material.

Figure 1 is a schematic of an isotropic and a unidirectional fiber-reinforced material. The stiffness of the isotropic plate can be described by one value, the modulus, E , of the material, regardless of direction of load. The stiffness of the orthotropic plate must be described by two values, one along the longitudinal direction of the fibers, commonly referred to as E_L , and one transverse to the direction of fibers, usually denoted by E_T . Subscripts 1 and 2 will be used such that $E_L = E_1$ and $E_T = E_2$. Thus, indices must be added to the stress, strain, and modulus values to describe the direction of the applied force. For example, for an isotropic material, the stress/strain relationship is written:

$$\sigma = E \epsilon \quad (1)$$

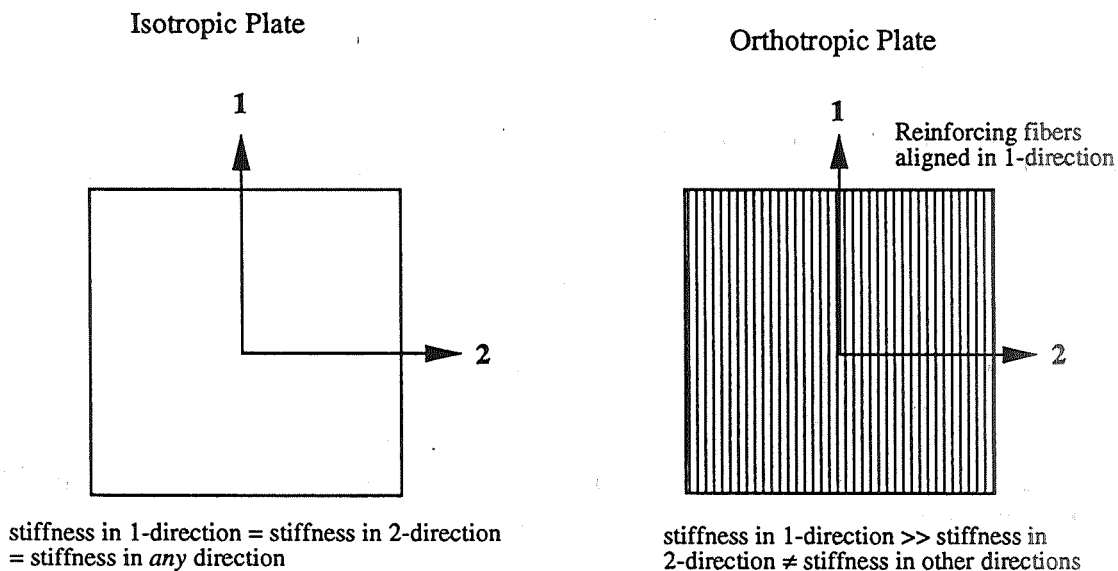

Figure 1. Difference between an isotropic and an orthotropic plate.

For the orthotropic system, the direction must be specified. For example:

$$\sigma_1 = E_1 \varepsilon_1 \quad \text{or} \quad \sigma_2 = E_2 \varepsilon_2 \quad . \quad (2)$$

If the applied load acts either parallel or perpendicular to the fibers, then the plate is considered specially orthotropic.

B. Stress and Strain, Plane Stress for Specially Orthotropic Plates

The previous section dealt with an extremely simple type of stress state, uniaxial. In general, plates will experience stresses in more than one direction within the plane. This is referred to as plane stress. In addition, Poisson's ratio now becomes important. Poisson's ratio is the ratio of the strain perpendicular to a given loading direction, to the strain parallel to this given loading direction:

$$\text{Poisson's ratio} = \nu_{12} = \frac{\varepsilon_T}{\varepsilon_L} = \frac{\varepsilon_2}{\varepsilon_1} \quad \text{or} \quad \nu_{21} = \frac{\varepsilon_L}{\varepsilon_T} = \frac{\varepsilon_1}{\varepsilon_2} \quad . \quad (3)$$

For loading along
the fibers
For loading
perpendicular to the fibers

The strain components are now stretch due to an applied force, minus the contraction of Poisson's effect due to another force perpendicular to this applied force. Thus:

$$\varepsilon_1 = \frac{\sigma_1}{E_1} - \nu_{21} \varepsilon_2 \quad \text{and} \quad \varepsilon_2 = \frac{\sigma_2}{E_2} - \nu_{12} \varepsilon_1 \quad . \quad (4a)$$

Using equation (2):

$$\varepsilon_1 = \frac{\sigma_1}{E_1} - \nu_{21} \frac{\sigma_2}{E_2} \quad \text{and} \quad \varepsilon_2 = \frac{\sigma_2}{E_2} - \nu_{12} \frac{\sigma_1}{E_1} \quad . \quad (4b)$$

Shear forces can also be present. Shear stress and shear strain are related by a constant, like the normal stresses and strains. This constant is called the shear modulus and is usually denoted by G . Thus:

$$\tau_{12} = \gamma_{12} G_{12} \quad . \quad (5)$$

Where τ_{12} is the shear stress (the 1 and the 2 indices indicating shear in the 1-2 plane), and γ_{12} is the shear strain. Figure 2 gives a definition of shear strain.

Since it is known that a relationship exists between Poisson's ratios and the moduli in each of the two axes directions, namely:

$$\nu_{21} E_1 = \nu_{12} E_2 \quad , \quad (6)$$

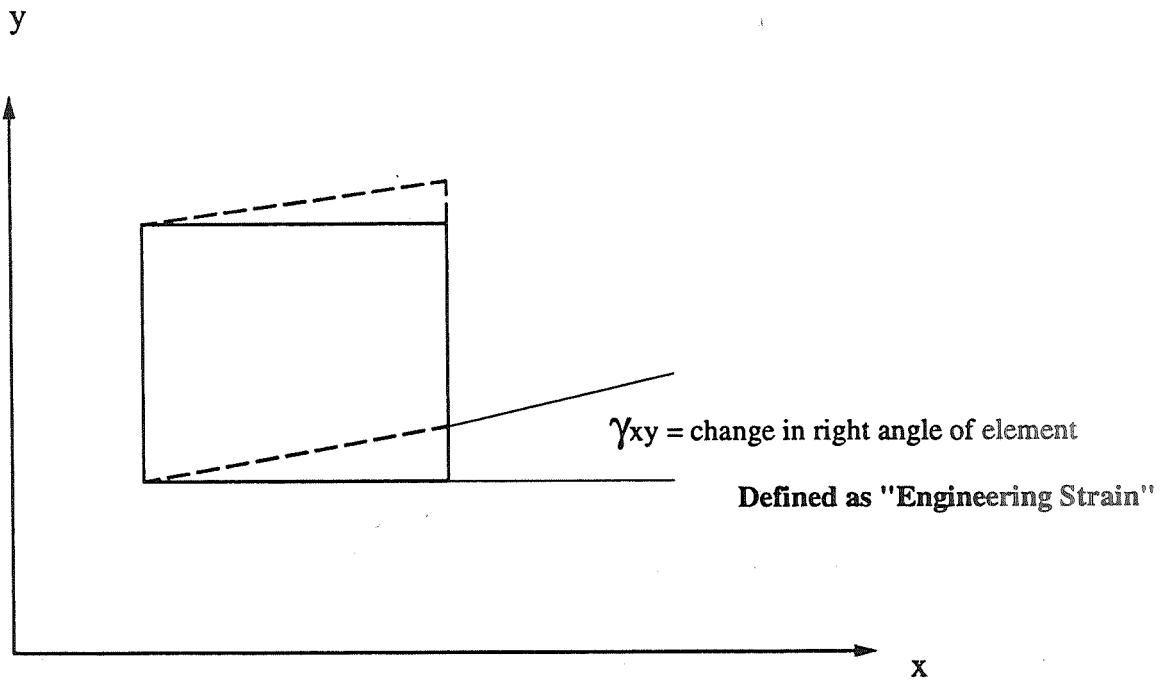

(a)

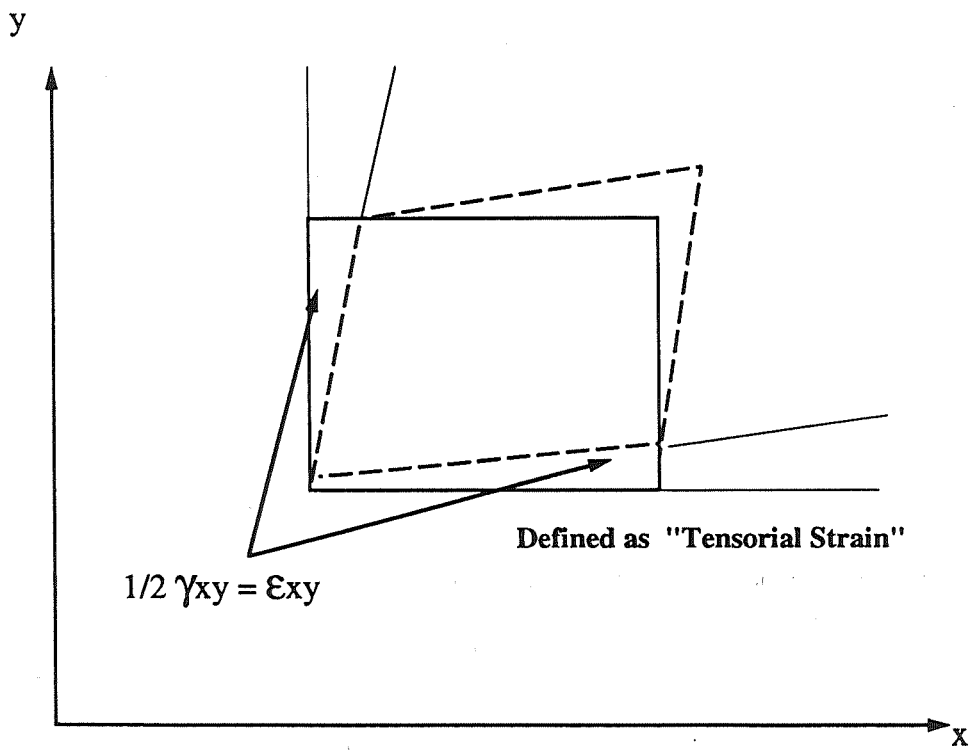

(b)

Figure 2. Definition of shearing strains.

Equations (4b) and (5) can be written in matrix form as:

$$\begin{bmatrix} \epsilon_1 \\ \epsilon_2 \\ \gamma_{12} \end{bmatrix} = \begin{bmatrix} S_{11} & S_{12} & 0 \\ S_{12} & S_{22} & 0 \\ 0 & 0 & S_{66} \end{bmatrix} \begin{bmatrix} \sigma_1 \\ \sigma_2 \\ \tau_{12} \end{bmatrix}, \quad (7)$$

where,

$$\begin{aligned} S_{11} &= 1/E_1 & S_{22} &= 1/E_2 \\ S_{12} &= -\nu_{12}/E_1 = -\nu_{21}/E_2 & S_{66} &= 1/G_{12} \end{aligned} \quad (8)$$

Note that at the 3,3 position in this 3x3 matrix (called the compliance matrix), the subscripts are 6,6. This evolves from a detailed treatment of arriving at a constitutive equation for an orthotropic material from an anisotropic one.

By inverting the compliance matrix, one can get stress as a function of strain. This turns out to be:

$$\begin{bmatrix} \sigma_1 \\ \sigma_2 \\ \tau_{12} \end{bmatrix} = \begin{bmatrix} Q_{11} & Q_{12} & 0 \\ Q_{12} & Q_{22} & 0 \\ 0 & 0 & Q_{66} \end{bmatrix} \begin{bmatrix} \epsilon_1 \\ \epsilon_2 \\ \gamma_{12} \end{bmatrix}, \quad (9)$$

where:

$$\begin{aligned} Q_{11} &= \frac{E_1}{1-\nu_{12}\nu_{21}}, & Q_{22} &= \frac{E_2}{1-\nu_{12}\nu_{21}}, \\ Q_{12} &= \frac{\nu_{12}E_2}{1-\nu_{12}\nu_{21}} = \frac{\nu_{21}E_1}{1-\nu_{12}\nu_{21}}, & Q_{66} &= G_{12}. \end{aligned} \quad (10)$$

The Q 's are referred to as the reduced stiffnesses and the matrix is abbreviated as $[Q]$.

C. Stress and Strain, Plane Stress for Generally Orthotropic Plates

Now suppose that the unidirectional lamina in figure 1 is loaded at some angle other than 0° or 90°. The lamina is now referred to as generally orthotropic, since, in general, the loading direction does not coincide with the principal material directions. The stresses and strains must now be transformed into coordinates that do coincide with the principal material directions. This can be accomplished using the free-body diagram in figure 3. From free body diagram (a), and summing forces in the 1-direction:

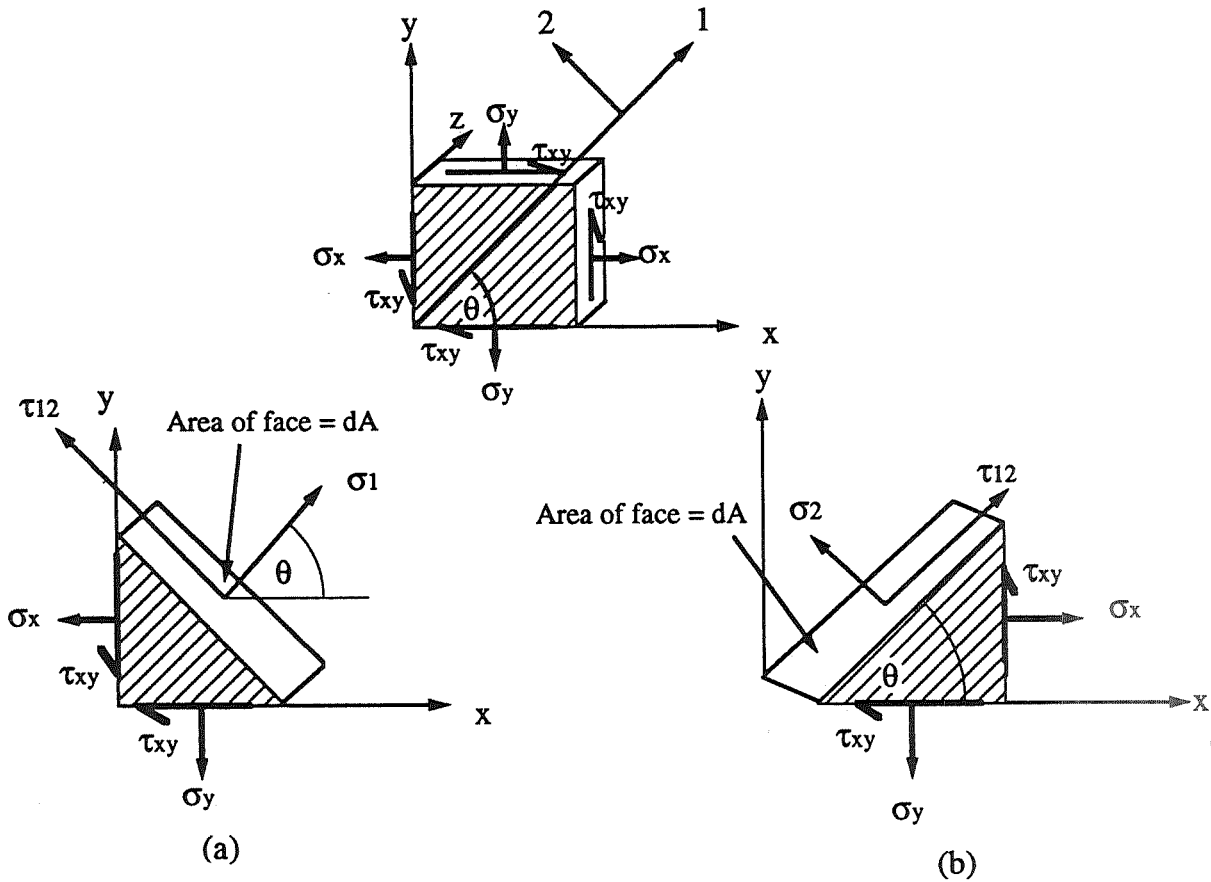

Figure 3. Generally orthotropic lamina.

$$\begin{aligned} \Sigma F_1 = 0 = & \sigma_1 dA - \sigma_x (dA \cos \theta) \cos \theta - \sigma_y (dA \sin \theta) \sin \theta \\ & - \tau_{xy} (dA \cos \theta) \sin \theta - \tau_{xy} (dA \sin \theta) \cos \theta \end{aligned} \quad (11)$$

From the free body diagram of figure 3(b) and summing forces in the 2-direction:

$$\begin{aligned} \Sigma F_2 = 0 = & \sigma_2 dA - \sigma_x (dA \sin \theta) \sin \theta - \sigma_y (dA \cos \theta) \cos \theta \\ & + \tau_{xy} (dA \cos \theta) \sin \theta + \tau_{xy} (dA \sin \theta) \cos \theta \end{aligned} \quad (12)$$

From free body diagram of figure 3(b) and summing forces in the 1-direction:

$$\begin{aligned} \Sigma F_2 = 0 = & \tau_{12} dA + \sigma_x (dA \sin \theta) \cos \theta - \sigma_y (dA \cos \theta) \sin \theta \\ & - \tau_{xy} (dA \cos \theta) \cos \theta + \tau_{xy} (dA \sin \theta) \sin \theta \end{aligned} \quad (13)$$

Simplifying equations (11), (12), and (13);

$$\begin{aligned}\sigma_1 &= \sigma_x \cos^2 \theta + \sigma_y \sin^2 \theta + 2\tau_{xy} \sin \theta \cos \theta, \\ \sigma_2 &= \sigma_x \sin^2 \theta + \sigma_y \cos^2 \theta - 2\tau_{xy} \sin \theta \cos \theta, \\ \tau_{12} &= -\sigma_x \sin \theta \cos \theta + \sigma_y \sin \theta \cos \theta + \tau_{xy} (\cos^2 \theta - \sin^2 \theta).\end{aligned}\tag{14}$$

Equation (14) can be written in matrix form as;

$$\begin{bmatrix} \sigma_1 \\ \sigma_2 \\ \tau_{12} \end{bmatrix} = \begin{bmatrix} \cos^2 \theta & \sin^2 \theta & 2 \sin \theta \cos \theta \\ \sin^2 \theta & \cos^2 \theta & -2 \sin \theta \cos \theta \\ -\sin \theta \cos \theta & \sin \theta \cos \theta & (\cos^2 \theta - \sin^2 \theta) \end{bmatrix} \begin{bmatrix} \sigma_x \\ \sigma_y \\ \tau_{xy} \end{bmatrix}.\tag{15}$$

The 3x3 matrix in equation (15) is called the transformation matrix and is denoted by $[T]$. The same matrix is used to transform strains. Note that the tensorial shear strain must be used, not the engineering shear strain, when transforming strains. This arises from the geometrical considerations that the amount of shear must be equivalent with respect to both the x - and y -axes, since these axes will be transformed into new ones (fig. 2(b)).

If it is desired to transform from the 1-2 coordinate system to the x - y coordinate system, the inverse of $[T]$ must be found. It is given by:

$$[T]^{-1} = \begin{bmatrix} \cos^2 \theta & \sin^2 \theta & -2 \sin \theta \cos \theta \\ \sin^2 \theta & \cos^2 \theta & 2 \sin \theta \cos \theta \\ \sin \theta \cos \theta & -\sin \theta \cos \theta & (\cos^2 \theta - \sin^2 \theta) \end{bmatrix}.\tag{16}$$

Thus;

$$\begin{bmatrix} \sigma_1 \\ \sigma_2 \\ \tau_{12} \end{bmatrix} = [T] \begin{bmatrix} \sigma_x \\ \sigma_y \\ \tau_{xy} \end{bmatrix} \quad \text{and} \quad \begin{bmatrix} \sigma_x \\ \sigma_y \\ \tau_{xy} \end{bmatrix} = [T]^{-1} \begin{bmatrix} \sigma_1 \\ \sigma_2 \\ \tau_{12} \end{bmatrix}.\tag{17}$$

Similarly for strain;

$$\begin{bmatrix} \varepsilon_1 \\ \varepsilon_2 \\ \varepsilon_{12} \end{bmatrix} = [T] \begin{bmatrix} \varepsilon_x \\ \varepsilon_y \\ \varepsilon_{xy} \end{bmatrix} \quad \text{and} \quad \begin{bmatrix} \varepsilon_x \\ \varepsilon_y \\ \varepsilon_{xy} \end{bmatrix} = [T]^{-1} \begin{bmatrix} \varepsilon_1 \\ \varepsilon_2 \\ \varepsilon_{12} \end{bmatrix} . \quad (18)$$

Putting equation (9) into the second part of equation in (17):

$$\begin{bmatrix} \sigma_x \\ \sigma_y \\ \tau_{xy} \end{bmatrix} = [T]^{-1} [Q] \begin{bmatrix} \varepsilon_1 \\ \varepsilon_2 \\ \gamma_{12} \end{bmatrix} = [T]^{-1} [Q] \begin{bmatrix} 1 & 0 & 0 \\ 0 & 1 & 0 \\ 0 & 0 & 2 \end{bmatrix} \begin{bmatrix} \varepsilon_1 \\ \varepsilon_2 \\ \varepsilon_{12} \end{bmatrix} . \quad (19)$$

Now putting the first equation of equation (18) into equation (19):

$$\begin{bmatrix} \sigma_x \\ \sigma_y \\ \tau_{xy} \end{bmatrix} = [T]^{-1} [Q] \begin{bmatrix} 1 & 0 & 0 \\ 0 & 1 & 0 \\ 0 & 0 & 2 \end{bmatrix} [T] \begin{bmatrix} \varepsilon_x \\ \varepsilon_y \\ \varepsilon_{xy} \end{bmatrix} . \quad (20)$$

Defining a new matrix called the lamina stiffness matrix (sometimes called “ \bar{Q} -Bar”) as:

$$[\bar{Q}] = [T]^{-1} [Q] \begin{bmatrix} 1 & 0 & 0 \\ 0 & 1 & 0 \\ 0 & 0 & 2 \end{bmatrix} [T] , \quad (21)$$

and letting:

$$m = \cos \theta ,$$

$$n = \sin \theta ,$$

the components are:

$$\begin{aligned} \bar{Q}_{11} &= Q_{11}m^4 + 2(Q_{12} + 2Q_{66})m^2n^2 + Q_{22}n^4 , \\ \bar{Q}_{12} &= (Q_{11} + Q_{22} - 4Q_{66})m^2n^2 + Q_{12}(m^4 + n^4) , \\ \bar{Q}_{22} &= Q_{11}n^4 + 2(Q_{12} + 2Q_{66})m^2n^2 + Q_{22}m^4 , \\ \bar{Q}_{16} &= (Q_{11} - Q_{12} - 2Q_{66})m^3n + (Q_{12} - Q_{22} + 2Q_{66})mn^3 , \end{aligned} \quad (22)$$

$$\begin{aligned}\bar{Q}_{26} &= (Q_{11} - Q_{12} - 2Q_{66})n^3m + (Q_{12} - Q_{22} + 2Q_{66})nm^3, \\ \bar{Q}_{66} &= (Q_{11} + Q_{22} - 2Q_{12} - 2Q_{66})m^2n^2 + Q_{66}(m^4 + n^4).\end{aligned}\tag{22} \text{ (cont.)}$$

Note that if θ is any angle other than zero, there will be nonzero \bar{Q}_{16} and \bar{Q}_{26} terms. Putting this into equation (20):

$$\begin{aligned}\begin{bmatrix} \sigma_x \\ \sigma_y \\ \tau_{xy} \end{bmatrix} &= \begin{bmatrix} \bar{Q}_{11} & \bar{Q}_{12} & 2\bar{Q}_{16} \\ \bar{Q}_{12} & \bar{Q}_{22} & 2\bar{Q}_{26} \\ \bar{Q}_{16} & \bar{Q}_{26} & 2\bar{Q}_{66} \end{bmatrix} \begin{bmatrix} \varepsilon_x \\ \varepsilon_y \\ \varepsilon_{xy} \end{bmatrix}, \\ \begin{bmatrix} \sigma_x \\ \sigma_y \\ \tau_{xy} \end{bmatrix} &= \begin{bmatrix} \bar{Q}_{11} & \bar{Q}_{12} & \bar{Q}_{16} \\ \bar{Q}_{12} & \bar{Q}_{22} & \bar{Q}_{26} \\ \bar{Q}_{16} & \bar{Q}_{26} & \bar{Q}_{66} \end{bmatrix} \begin{bmatrix} \varepsilon_x \\ \varepsilon_y \\ \gamma_{xy} \end{bmatrix},\end{aligned}\tag{23}$$

it can be seen that a shear strain will produce normal stresses, and normal strains will contribute to a shear stress. This is referred to as extension-shear coupling and will take place in a lamina that is loaded at an angle to the fibers (other than 0° and 90°). That is, there will be coupling if the \bar{Q}_{16} and/or \bar{Q}_{26} terms in the lamina stiffness matrix are nonzero.

D. Invariant Stiffnesses

The “Q-Bar” terms can be written as:

$$\begin{aligned}\bar{Q}_{11} &= U_1 + U_2 \cos(2\theta) + U_3 \cos(4\theta), \\ \bar{Q}_{22} &= U_1 - U_2 \cos(2\theta) + U_3 \cos(4\theta), \\ \bar{Q}_{12} &= U_4 - U_3 \cos(4\theta), \\ \bar{Q}_{66} &= U_5 - U_3 \cos(4\theta), \\ \bar{Q}_{16} &= \frac{1}{2} U_2 \sin(2\theta) + U_3 \sin(4\theta), \\ \bar{Q}_{26} &= \frac{1}{2} U_2 \sin(2\theta) - U_3 \sin(4\theta),\end{aligned}\tag{24a}$$

where,

$$\begin{aligned}
 U_1 &= \frac{3}{8} (Q_{11} + Q_{22}) + \frac{1}{4} Q_{12} + \frac{1}{2} Q_{66} , \\
 U_2 &= \frac{1}{2} (Q_{11} - Q_{22}) , \\
 U_3 &= \frac{1}{8} (Q_{11} + Q_{22}) - \frac{1}{4} Q_{12} - \frac{1}{2} Q_{66} , \\
 U_4 &= \frac{1}{8} (Q_{11} + Q_{22}) + \frac{3}{4} Q_{12} - \frac{1}{2} Q_{66} , \\
 U_5 &= \frac{1}{8} (Q_{11} + Q_{22}) - \frac{1}{4} Q_{12} + \frac{1}{2} Q_{66} .
 \end{aligned} \tag{24b}$$

Note that only U_2 and U_3 are coefficients to the sine or cosine terms in equation (24a). This implies that when calculating the Q -Bar values, U_1 , U_4 , and U_5 are independent or invariant to the ply orientation θ . This concept of “invariant” quantities can make some calculations easier. This paper will not go into detail on this subject since only the basics are being presented.

III. MECHANICS OF LAMINATED COMPOSITES

A. Assumptions

The following assumptions are made for the remainder of this paper:

- (1) The laminate thickness is very small compared to its other dimensions.
- (2) The lamina (layers) of the laminate are perfectly bonded.
- (3) Lines perpendicular to the surface of the laminate remain straight and perpendicular to the surface after deformation.
- (4) The laminae and laminate are linear elastic.
- (5) The through-the-thickness stresses and strains are negligible.

These assumptions are good ones as long as the laminate is not damaged and undergoes small deflections.

B. Definitions of Strains and Displacements

A displacement of the plate in the x -direction is designated as u . For the y -direction, it is designated as v and for the z -direction w . Figure 4 shows these displacements. The strains are now defined as:

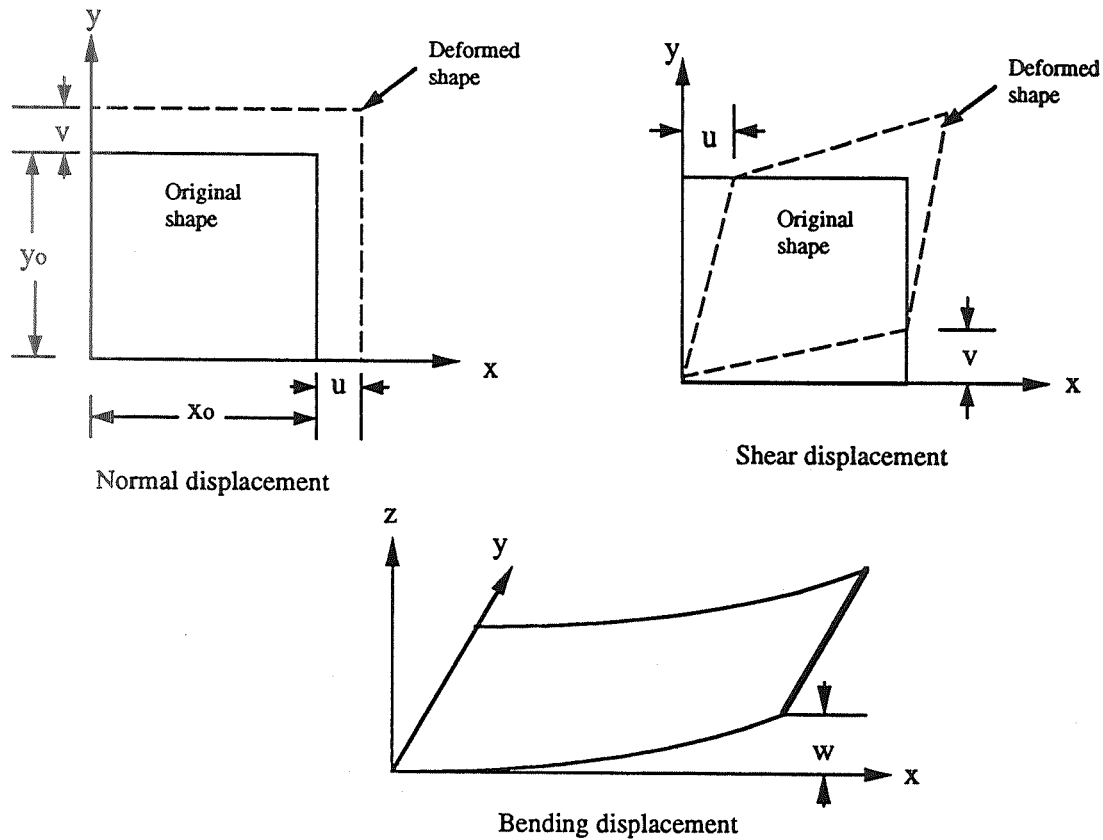

Figure 4. Displacements of a plate.

$$\epsilon_x \equiv \frac{\partial u}{\partial x} ; \quad \epsilon_y \equiv \frac{\partial v}{\partial y} ; \quad \gamma_{xy} \equiv \left(\frac{\partial u}{\partial y} + \frac{\partial v}{\partial x} \right) . \quad (25a)$$

The slope of the plate if it is bending is given as:

$$\begin{aligned} \frac{\partial w}{\partial x} & \text{ along the } x\text{-direction} , \\ \frac{\partial w}{\partial y} & \text{ along the } y\text{-direction} . \end{aligned} \quad (25b)$$

The total in-plane displacement at any point in the plate is the sum of the normal displacements plus the displacements introduced by bending. Denoting the displacements of the midplane of the plate for the x and y directions as u_o and v_o respectively, with the help of figure 5 the total displacements are:

$$u = u_o - z \frac{\partial w}{\partial x} ; \quad v = v_o - z \frac{\partial w}{\partial y} . \quad (26)$$

Note that for figure 5, x can be replaced by y when u is replaced by v (i.e., the view could be from any side of the plate). It is assumed that there is no strain in the thickness direction, only a displacement.

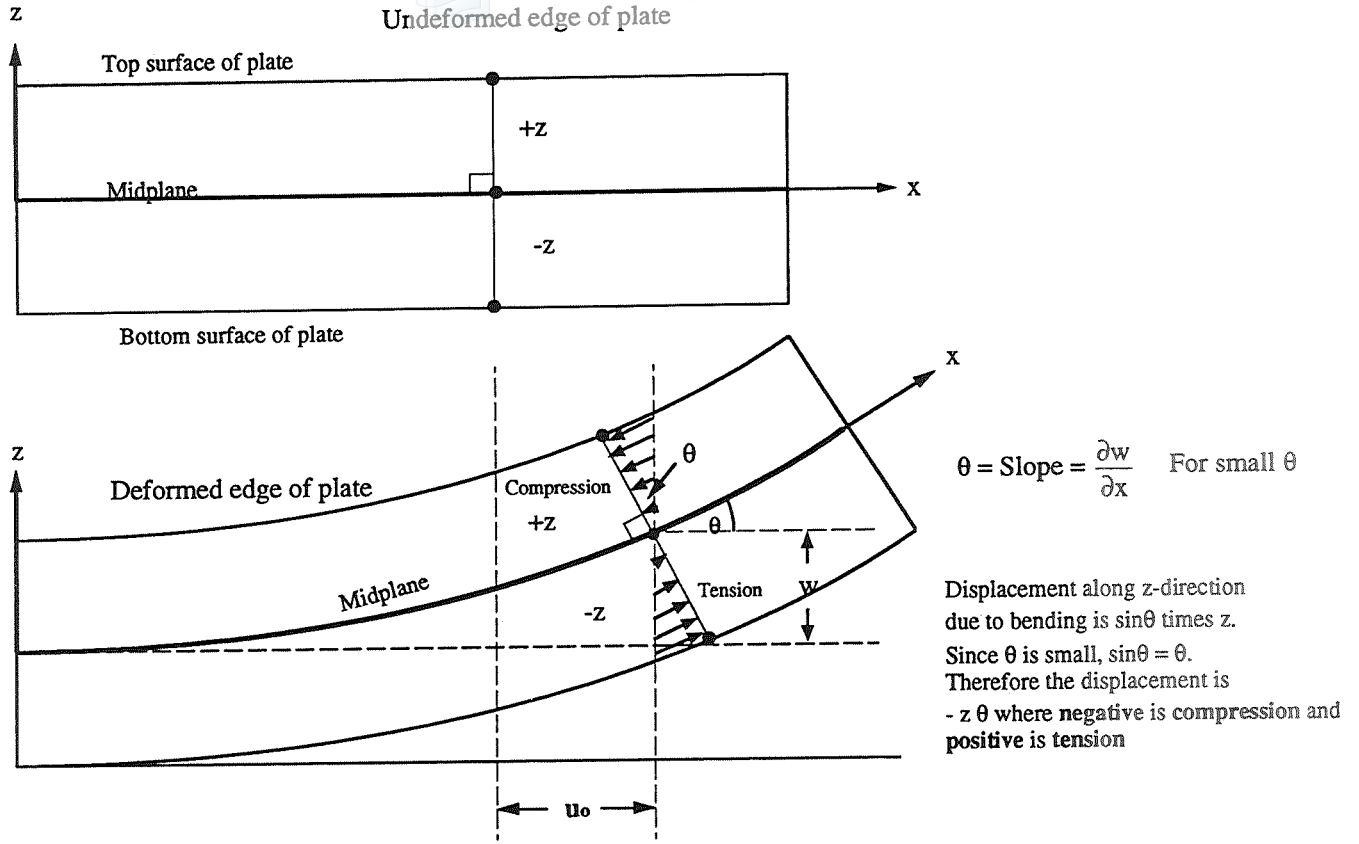

Figure 5. Total displacements in a plate.

From equations (25) and (26):

$$\epsilon_x = \frac{\partial u}{\partial x} = \frac{\partial u_o}{\partial x} - z \frac{\partial^2 w}{\partial x^2},$$

$$\epsilon_y = \frac{\partial v}{\partial y} = \frac{\partial v_o}{\partial y} - z \frac{\partial^2 w}{\partial y^2},$$

$$\gamma_{xy} = \frac{\partial u}{\partial y} + \frac{\partial v}{\partial x} = \frac{\partial u_o}{\partial y} + \frac{\partial v_o}{\partial x} - 2z \frac{\partial^2 w}{\partial x \partial y}.$$

Defining:

$$\frac{\partial u_o}{\partial x} \text{ as } \epsilon_x^o; \quad \frac{\partial v_o}{\partial y} \text{ as } \epsilon_y^o; \quad \text{and} \quad \frac{\partial u_o}{\partial y} + \frac{\partial v_o}{\partial x} \text{ as } \gamma_{xy}^o,$$

to be the midplane strains and defining:

$$-\frac{\partial^2 w}{\partial x^2} \text{ as } K_x; \quad -\frac{\partial^2 w}{\partial y^2} \text{ as } K_y; \quad \text{and} \quad -2\frac{\partial^2 w}{\partial x \partial y} \text{ as } K_{xy},$$

to be the plate curvatures will make notation easier.

Equation (27) can now be written in matrix form as:

$$\begin{bmatrix} \epsilon_x \\ \epsilon_y \\ \gamma_{xy} \end{bmatrix} = \begin{bmatrix} \epsilon_x^o \\ \epsilon_y^o \\ \gamma_{xy}^o \end{bmatrix} + z \begin{bmatrix} K_x \\ K_y \\ K_{xy} \end{bmatrix} \quad (30)$$

From figure 6, it can be seen that the plate curvature K_x or K_y is the rate of change of slope of the bending plate in either the x - or y -direction, respectively. The plate curvature term K_{xy} is the amount of bending in the x -direction along the y -axis (i.e., twisting).

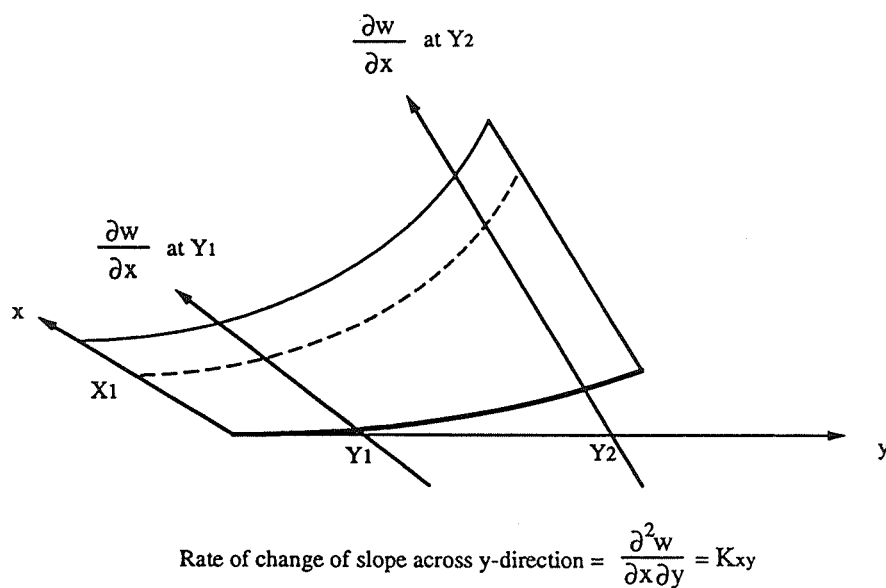
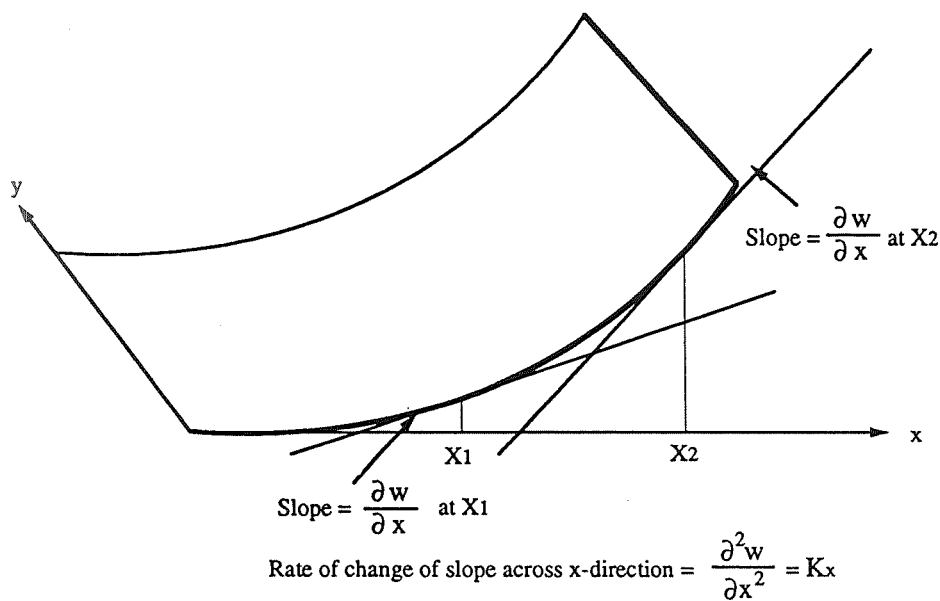

Figure 6. Definitions of plate curvatures.

(30): From equation (23), the stresses in each ply of the laminate can be determined with equation

$$\begin{bmatrix} \sigma_x \\ \sigma_y \\ \tau_{xy} \end{bmatrix} = \begin{bmatrix} \bar{Q}_{11} & \bar{Q}_{12} & \bar{Q}_{16} \\ \bar{Q}_{12} & \bar{Q}_{22} & \bar{Q}_{26} \\ \bar{Q}_{16} & \bar{Q}_{26} & \bar{Q}_{66} \end{bmatrix} \begin{bmatrix} \epsilon_x^0 \\ \epsilon_y^0 \\ \gamma_{xy}^0 \end{bmatrix} + z \begin{bmatrix} \bar{Q}_{11} & \bar{Q}_{12} & \bar{Q}_{16} \\ \bar{Q}_{12} & \bar{Q}_{22} & \bar{Q}_{26} \\ \bar{Q}_{16} & \bar{Q}_{26} & \bar{Q}_{66} \end{bmatrix} \begin{bmatrix} K_x \\ K_y \\ K_{xy} \end{bmatrix} \quad (30a)$$

C. Definitions of Stress and Moment Resultants

Since the stress in each ply varies through the thickness of the laminate, it will be convenient to define stresses in terms of equivalent forces acting at the middle surface. Referring to figure 7, it can be seen that the stresses acting on an edge can be broken into increments and summed. The resulting integral is defined as the stress resultant and is denoted by N_i , where the i subscript denotes direction. This stress resultant has units of force per length and acts in the same direction

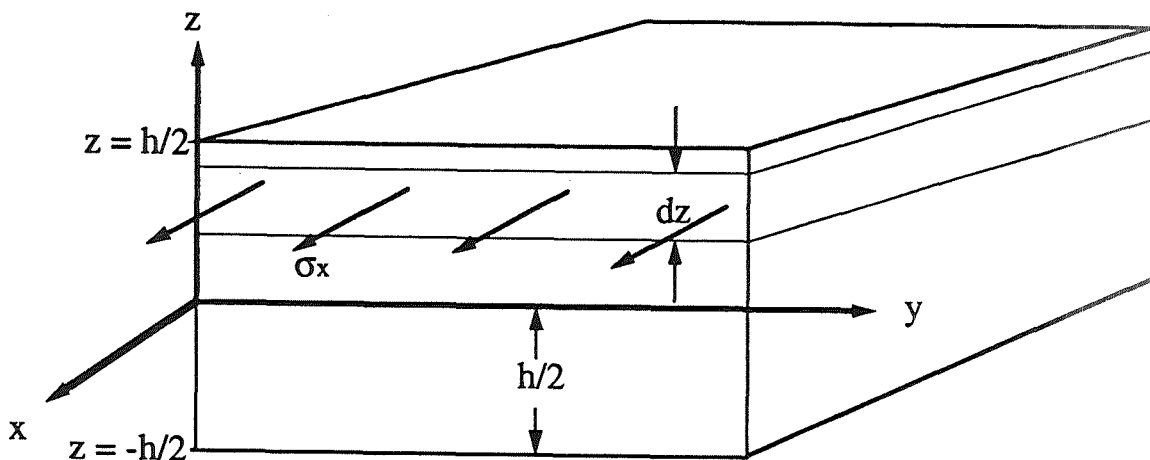

$$\text{Total force in x-direction} = \sum \sigma_x(dz)(y)$$

$$\text{As } dz \rightarrow 0, \sum \sigma_x (dz)(y) = y \int_{-h/2}^{h/2} \sigma_x dz$$

$$N_x \equiv \int_{-h/2}^{h/2} \sigma_x dz$$

Figure 7. Definition of stress resultant.

as the stress state it represents. Figure 7 could also be drawn for the y-direction stress and shear stress. The three stress resultants are therefore:

$$\begin{aligned} N_x &\equiv \int_{-h/2}^{h/2} \sigma_x dz , \\ N_y &\equiv \int_{-h/2}^{h/2} \sigma_y dz , \\ N_{xy} &\equiv \int_{-h/2}^{h/2} \tau_{xy} dz . \end{aligned} \tag{31}$$

As can be seen from figure 7, the stress acting on an edge produces a moment about the midplane. The force is $\sigma_x (dz)(y)$ as denoted in figure 7. The moment arm is at a distance z from the midplane. Following the same procedure as for the stress resultants, the moment resultants can be defined as:

$$\begin{aligned} M_x &\equiv \int_{-h/2}^{h/2} \sigma_x z dz , \\ M_y &\equiv \int_{-h/2}^{h/2} \sigma_y z dz , \\ M_{xy} &\equiv \int_{-h/2}^{h/2} \tau_{xy} z dz . \end{aligned} \tag{32}$$

These moment resultants have units of torque per unit length.

The directions for all of the stress and moment resultants are shown in figure 8 for clarity. The double-headed arrow indicates torque in a direction determined by the right-hand-rule (i.e., point the thumb of your right hand in the direction of the double-headed arrows and the direction of rotation of the torque is in the direction that your four fingers are pointing). Note that M_x and M_y will cause the plate to bend and M_{xy} will cause the plate to twist.

As an example of the relationship between stress and stress resultants, if a tensile test specimen is 2.54-cm (1-in) wide and 2-mm (0.08-in) thick, and is pulled on with a force of 4,500 N (1,000 lb), then the average stress on the cross section is:

$$\bar{\sigma}_x = \frac{4,500 \text{ N}}{(0.0254 \text{ m})(0.002 \text{ m})} = 88.6 \text{ MPa} = 12,500 \frac{\text{lb}}{\text{in}^2} . \tag{33}$$

The stress resultant would be the average stress multiplied by the specimen thickness:

$$N_x = (88.6 \text{ MPa})(0.002 \text{ m}) = 177.2 \frac{\text{kN}}{\text{m}} = 1,000 \frac{\text{lb}}{\text{in}} . \tag{34}$$

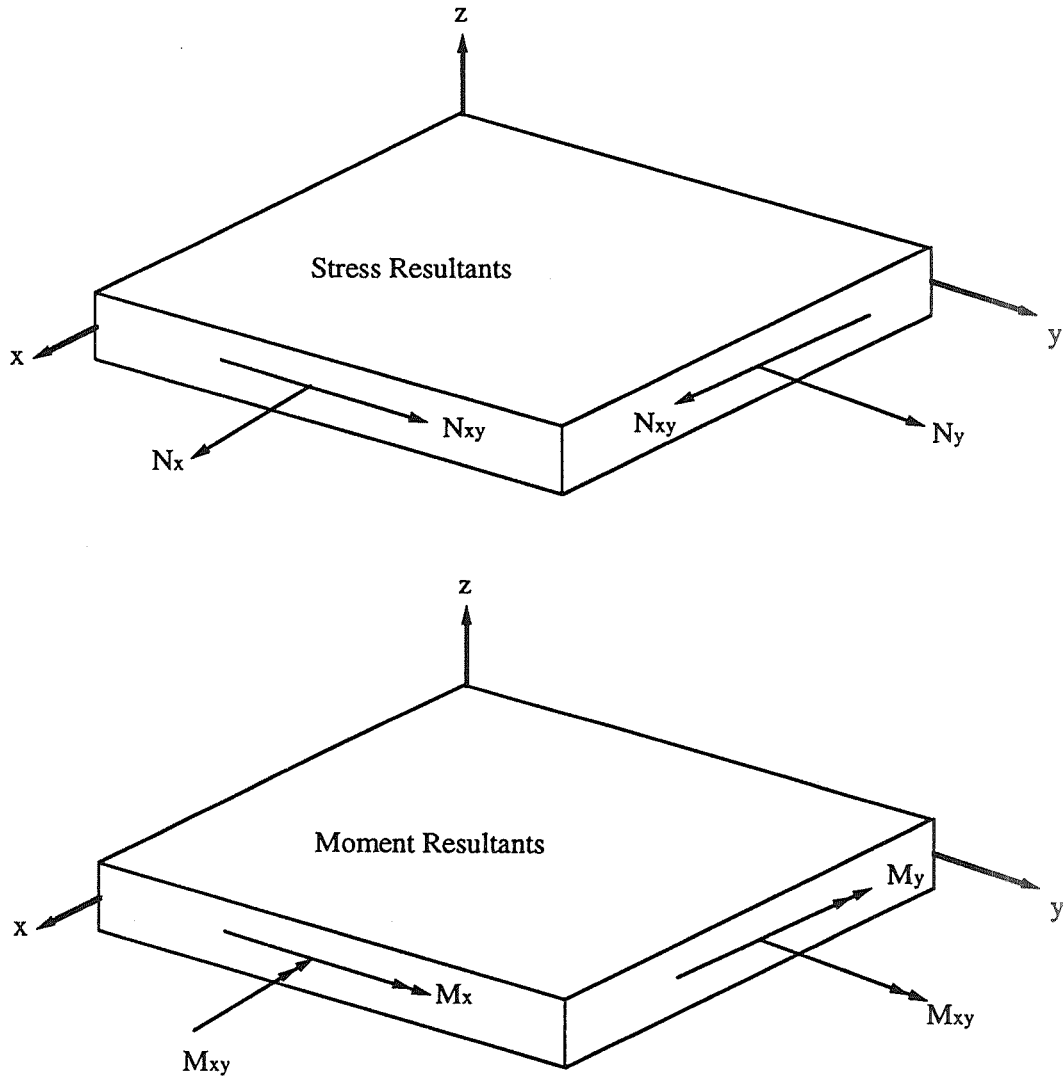

Figure 8. Direction of stress and moment resultants.

Since 1,000 lb was applied over 1 inch of specimen length, the expected result of 1,000 lb/in is obtained. Each individual ply of the specimen may have a stress other than 88.6 MPa (12,500 lb/in²), but the average stress will be 88.6 MPa (12,500 lb/in²).

D. Constitutive Equations for a Laminate

Putting equation (31) in matrix form:

$$\begin{bmatrix} N_x \\ N_y \\ N_{xy} \end{bmatrix} = \int_{-h/2}^{h/2} \begin{bmatrix} \sigma_x \\ \sigma_y \\ \tau_{xy} \end{bmatrix} dz , \quad (35)$$

and putting equation (32) in matrix form also:

$$\begin{bmatrix} M_x \\ M_y \\ M_{xy} \end{bmatrix} = \int_{-h/2}^{h/2} \begin{bmatrix} \sigma_x \\ \sigma_y \\ \tau_{xy} \end{bmatrix} z dz \quad . \quad (36)$$

The integrals in equations (35) and (36) must be performed over each ply and then summed, since discontinuities in stresses can occur at ply interfaces. Using the schematic of a laminate in figure 9, equations (35) and (36) must be written as:

$$\begin{bmatrix} N_x \\ N_y \\ N_{xy} \end{bmatrix} = \sum_{k=1}^n \int_{h_{k-1}}^{h_k} \begin{bmatrix} \sigma_x \\ \sigma_y \\ \tau_{xy} \end{bmatrix}_k dz \quad , \quad (37)$$

and,

$$\begin{bmatrix} M_x \\ M_y \\ M_{xy} \end{bmatrix} = \sum_{k=1}^n \int_{h_{k-1}}^{h_k} \begin{bmatrix} \sigma_x \\ \sigma_y \\ \tau_{xy} \end{bmatrix}_k z dz \quad . \quad (38)$$

Now equation (30) can be substituted into equation (23), which can then be substituted into equations (37) and (38) to give:

$$\begin{bmatrix} N_x \\ N_y \\ N_{xy} \end{bmatrix} = \sum_{k=1}^n \left\{ \int_{h_{k-1}}^{h_k} \begin{bmatrix} \bar{Q}_{11} & \bar{Q}_{12} & \bar{Q}_{16} \\ \bar{Q}_{12} & \bar{Q}_{22} & \bar{Q}_{26} \\ \bar{Q}_{16} & \bar{Q}_{26} & \bar{Q}_{66} \end{bmatrix}_k \begin{bmatrix} \varepsilon_x^0 \\ \varepsilon_y^0 \\ \gamma_{xy}^0 \end{bmatrix} dz \right. \\ \left. + \int_{h_{k-1}}^{h_k} \begin{bmatrix} \bar{Q}_{11} & \bar{Q}_{12} & \bar{Q}_{16} \\ \bar{Q}_{12} & \bar{Q}_{22} & \bar{Q}_{26} \\ \bar{Q}_{16} & \bar{Q}_{26} & \bar{Q}_{66} \end{bmatrix}_k \begin{bmatrix} K_x \\ K_y \\ K_{xy} \end{bmatrix} z dz \right\} \quad , \quad (39)$$

and,

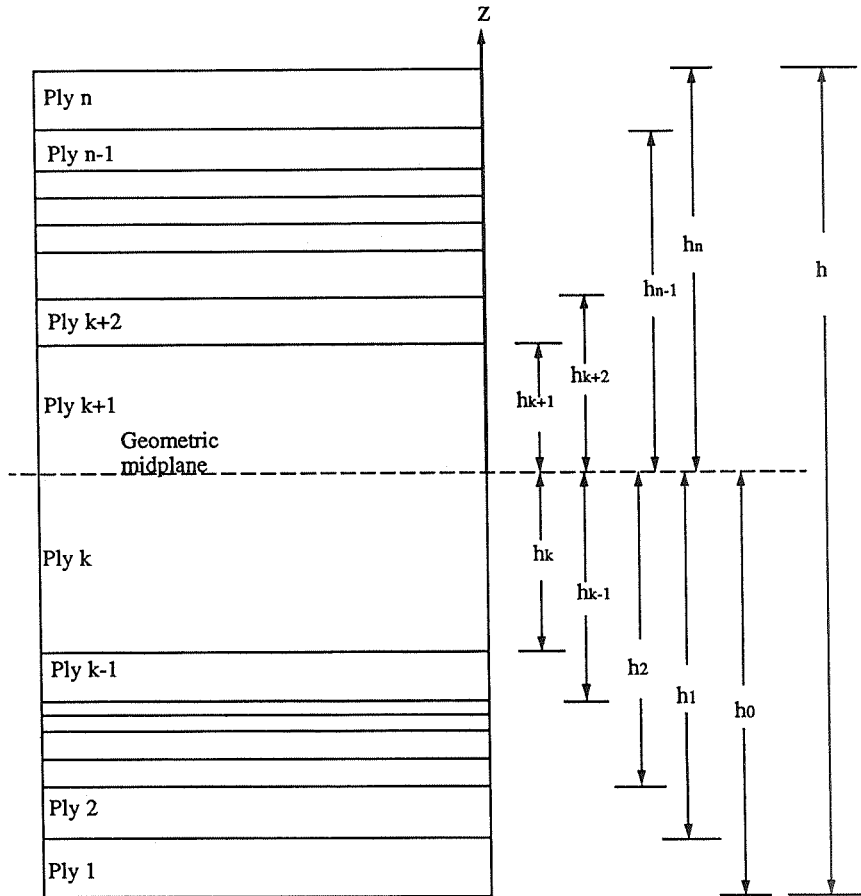

Note that ply k and ply k+1 are the same lamina (layer), but are separated into two plies by the geometric midplane.

Figure 9. Cross section of a laminate.

$$\begin{aligned}
 \begin{bmatrix} M_x \\ M_y \\ M_{xy} \end{bmatrix} &= \sum_{k=1}^n \left\{ \int_{h_{k-1}}^{h_k} \begin{bmatrix} \bar{Q}_{11} & \bar{Q}_{12} & \bar{Q}_{16} \\ \bar{Q}_{12} & \bar{Q}_{22} & \bar{Q}_{26} \\ \bar{Q}_{16} & \bar{Q}_{26} & \bar{Q}_{66} \end{bmatrix}_k \begin{bmatrix} \varepsilon_x^0 \\ \varepsilon_y^0 \\ \gamma_{xy}^0 \end{bmatrix} z dz \right. \\
 &\quad \left. + \int_{h_{k-1}}^{h_k} \begin{bmatrix} \bar{Q}_{11} & \bar{Q}_{12} & \bar{Q}_{16} \\ \bar{Q}_{12} & \bar{Q}_{22} & \bar{Q}_{26} \\ \bar{Q}_{16} & \bar{Q}_{26} & \bar{Q}_{66} \end{bmatrix}_k \begin{bmatrix} K_x \\ K_y \\ K_{xy} \end{bmatrix} z^2 dz \right\}. \tag{40}
 \end{aligned}$$

Since the middle surface strains and curvatures (the ϵ^0 's and K 's) are not a function of z (because these values are always at the middle surface $z = 0$), they need not be included in the integration. Also, the laminate stiffness matrix is constant for a given ply, so it too will be a constant over the integration of a lamina thickness. Pulling these constants to the front of the integral in equations (39) and (40) gives:

$$\begin{aligned} \begin{bmatrix} N_x \\ N_y \\ N_{xy} \end{bmatrix} &= \sum_{k=1}^n \left\{ \begin{bmatrix} \bar{Q}_{11} & \bar{Q}_{12} & \bar{Q}_{16} \\ \bar{Q}_{12} & \bar{Q}_{22} & \bar{Q}_{26} \\ \bar{Q}_{16} & \bar{Q}_{26} & \bar{Q}_{66} \end{bmatrix}_k \begin{bmatrix} \epsilon_x^0 \\ \epsilon_y^0 \\ \gamma_{xy}^0 \end{bmatrix} \int_{h_{k-1}}^{h_k} dz \right. \\ &\quad \left. + \begin{bmatrix} \bar{Q}_{11} & \bar{Q}_{12} & \bar{Q}_{16} \\ \bar{Q}_{12} & \bar{Q}_{22} & \bar{Q}_{26} \\ \bar{Q}_{16} & \bar{Q}_{26} & \bar{Q}_{66} \end{bmatrix}_k \begin{bmatrix} K_x \\ K_y \\ K_{xy} \end{bmatrix} \int_{h_{k-1}}^{h_k} z dz \right\}, \end{aligned} \quad (41)$$

and

$$\begin{aligned} \begin{bmatrix} M_x \\ M_y \\ M_{xy} \end{bmatrix} &= \sum_{k=1}^n \left\{ \begin{bmatrix} \bar{Q}_{11} & \bar{Q}_{12} & \bar{Q}_{16} \\ \bar{Q}_{12} & \bar{Q}_{22} & \bar{Q}_{26} \\ \bar{Q}_{16} & \bar{Q}_{26} & \bar{Q}_{66} \end{bmatrix}_k \begin{bmatrix} \epsilon_x^0 \\ \epsilon_y^0 \\ \gamma_{xy}^0 \end{bmatrix} \int_{h_{k-1}}^{h_k} z dz \right. \\ &\quad \left. + \begin{bmatrix} \bar{Q}_{11} & \bar{Q}_{12} & \bar{Q}_{16} \\ \bar{Q}_{12} & \bar{Q}_{22} & \bar{Q}_{26} \\ \bar{Q}_{16} & \bar{Q}_{26} & \bar{Q}_{66} \end{bmatrix}_k \begin{bmatrix} K_x \\ K_y \\ K_{xy} \end{bmatrix} \int_{h_{k-1}}^{h_k} z^2 dz \right\}. \end{aligned} \quad (42)$$

Performing the simple integrations gives:

$$\begin{aligned} \begin{bmatrix} N_x \\ N_y \\ N_{xy} \end{bmatrix} &= \sum_{k=1}^n \left\{ \begin{bmatrix} \bar{Q}_{11} & \bar{Q}_{12} & \bar{Q}_{16} \\ \bar{Q}_{12} & \bar{Q}_{22} & \bar{Q}_{26} \\ \bar{Q}_{16} & \bar{Q}_{26} & \bar{Q}_{66} \end{bmatrix}_k \begin{bmatrix} \epsilon_x^0 \\ \epsilon_y^0 \\ \gamma_{xy}^0 \end{bmatrix} (h_k - h_{k-1}) \right. \\ &\quad \left. + \begin{bmatrix} \bar{Q}_{11} & \bar{Q}_{12} & \bar{Q}_{16} \\ \bar{Q}_{12} & \bar{Q}_{22} & \bar{Q}_{26} \\ \bar{Q}_{16} & \bar{Q}_{26} & \bar{Q}_{66} \end{bmatrix}_k \begin{bmatrix} K_x \\ K_y \\ K_{xy} \end{bmatrix} \frac{1}{2} (h_k^2 - h_{k-1}^2) \right\}, \end{aligned} \quad (43)$$

and

$$\begin{aligned} \begin{bmatrix} M_x \\ M_y \\ M_{xy} \end{bmatrix} &= \sum_{k=1}^n \left\{ \begin{bmatrix} \bar{Q}_{11} & \bar{Q}_{12} & \bar{Q}_{16} \\ \bar{Q}_{12} & \bar{Q}_{22} & \bar{Q}_{26} \\ \bar{Q}_{16} & \bar{Q}_{26} & \bar{Q}_{66} \end{bmatrix}_k \begin{bmatrix} \varepsilon_x^0 \\ \varepsilon_y^0 \\ \gamma_{xy}^0 \end{bmatrix} \frac{1}{2} (h_k^2 - h_{k-1}^2) \right. \\ &\quad \left. + \begin{bmatrix} \bar{Q}_{11} & \bar{Q}_{12} & \bar{Q}_{16} \\ \bar{Q}_{12} & \bar{Q}_{22} & \bar{Q}_{26} \\ \bar{Q}_{16} & \bar{Q}_{26} & \bar{Q}_{66} \end{bmatrix}_k \begin{bmatrix} K_x \\ K_y \\ K_{xy} \end{bmatrix} \frac{1}{3} (h_k^3 - h_{k-1}^3) \right\} . \end{aligned} \quad (44)$$

Since the middle surface strains and curvatures are not a part of the summations, the laminate stiffness matrix and the h_k terms can be combined to form new matrices. From equations (43) and (44), these can be defined as:

$$A_{ij} = \sum_{k=1}^n [\bar{Q}_{ij}]_k (h_k - h_{k-1}) , \quad (45)$$

$$B_{ij} = \frac{1}{2} \sum_{k=1}^n [\bar{Q}_{ij}]_k (h_k^2 - h_{k-1}^2) , \quad (46)$$

$$D_{ij} = \frac{1}{3} \sum_{k=1}^n [\bar{Q}_{ij}]_k (h_k^3 - h_{k-1}^3) . \quad (47)$$

In matrix form, the constitutive equations can easily be written as:

$$\begin{bmatrix} N_x \\ N_y \\ N_{xy} \\ \hline M_x \\ M_y \\ M_{xy} \end{bmatrix} = \begin{bmatrix} A_{11} & A_{12} & A_{16} & | & B_{11} & B_{12} & B_{16} \\ A_{12} & A_{22} & A_{26} & | & B_{12} & B_{22} & B_{26} \\ A_{16} & A_{26} & A_{66} & | & B_{16} & B_{26} & B_{66} \\ \hline B_{11} & B_{12} & B_{16} & | & D_{11} & D_{12} & D_{16} \\ B_{12} & B_{22} & B_{26} & | & D_{12} & D_{22} & D_{26} \\ B_{16} & B_{26} & B_{66} & | & D_{16} & D_{26} & D_{66} \end{bmatrix} \begin{bmatrix} \varepsilon_x^0 \\ \varepsilon_y^0 \\ \gamma_{xy}^0 \\ \hline K_x \\ K_y \\ K_{xy} \end{bmatrix} . \quad (48)$$

Written in contracted form, equation (48) becomes:

$$\begin{bmatrix} N \\ M \end{bmatrix} = \begin{bmatrix} A & | & B \\ \hline B & | & D \end{bmatrix} \begin{bmatrix} \varepsilon^0 \\ \hline K \end{bmatrix} \quad (49)$$

This can be partially inverted to give:

$$\begin{bmatrix} \frac{\epsilon^0}{M} \end{bmatrix} = \begin{bmatrix} A^* & | & B^* \\ \hline C^* & | & D^* \end{bmatrix} \begin{bmatrix} \frac{N}{K} \end{bmatrix}, \quad (50)$$

where,

$$[A^*] = [A]^{-1},$$

$$[B^*] = -[A]^{-1}[B],$$

$$[C^*] = [B][A]^{-1},$$

$$[D^*] = [D] - [B][A]^{-1}[B].$$

(51)

The fully inverted form is given by:

$$\begin{bmatrix} \frac{\epsilon_x^0}{\epsilon_x^0}{\gamma_x^0} \\ \hline K_x \\ K_y \\ K_{xy} \end{bmatrix} = \begin{bmatrix} A'_{11} & A'_{12} & A'_{16} & | & B'_{11} & B'_{12} & B'_{16} \\ A'_{12} & A'_{22} & A'_{26} & | & B'_{12} & B'_{22} & B'_{26} \\ A'_{16} & A'_{26} & A'_{66} & | & B'_{16} & B'_{26} & B'_{66} \\ \hline C'_{11} & C'_{12} & C'_{16} & | & D'_{11} & D'_{12} & D'_{16} \\ C'_{12} & C'_{22} & C'_{26} & | & D'_{12} & D'_{22} & D'_{26} \\ C'_{16} & C'_{26} & C'_{66} & | & D'_{16} & D'_{26} & D'_{66} \end{bmatrix} \begin{bmatrix} N_x \\ N_y \\ N_{xy} \\ \hline M_x \\ M_y \\ M_{xy} \end{bmatrix}, \quad (52)$$

where,

$$[A'] = [A^*] - [B^*][D^*]^{-1}[C^*],$$

$$[B'] = [B^*][D^*]^{-1},$$

$$[C'] = -[D^*]^{-1}[C^*],$$

$$[D'] = [D^*]^{-1}.$$

(52a)

The fully inverted form is the most often used form of the laminate constitutive equations.

For symmetric laminates (laminates that are configured such that the geometric midplane is a mirror image of the ply configurations above and below the midplane), the geometric midplane is also the neutral plane of the plate, and the $[B]$ matrix will have all elements equal to zero (as will be shown later). However, if the laminate is unsymmetric, i.e., if the plies near the bottom of the plate are much stiffer in the x -direction, then the geometric midplane will not be the neutral plane of the plate; and the neutral plane will be closer to the bottom of the plate for x -direction bending as shown in figure 10. This is accounted for in the constitutive equations, since the $[B]$ matrix will have some nonzero elements (as will be shown later), implying that a bending strain (plate curvature) will cause a midplane strain as depicted in figure 10. Likewise, a midplane strain will cause a bending moment. A method to find the neutral axis of the plate will be discussed in a later section about stresses within the plies of a laminate.

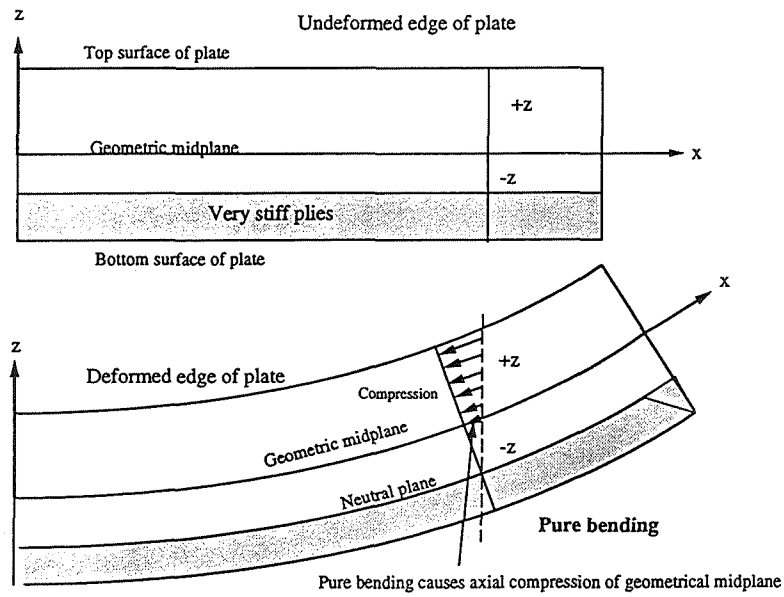

Figure 10. Displacements in an unsymmetrical plate.

E. Physical Meanings of the $[A]$, $[B]$, and $[D]$ Matrices

Recalling the definitions of the $[A]$, $[B]$, and $[D]$ matrices,

$$A_{ij} = \sum_{k=1}^n [\bar{Q}_{ij}]_k (h_k - h_{k-1}) , \quad (45)$$

$$B_{ij} = \frac{1}{2} \sum_{k=1}^n [\bar{Q}_{ij}]_k (h_k^2 - h_{k-1}^2) , \quad (46)$$

$$D_{ij} = \frac{1}{3} \sum_{k=1}^n [\bar{Q}_{ij}]_k (h_k^3 - h_{k-1}^3) , \quad (47)$$

and referring to figure 9, it can be seen that the last term in equation (45) is the k th lamina thickness which will be denoted by t_k . Thus, equation (45) can be written as:

$$A_{ij} = \sum_{k=1}^n [\bar{Q}_{ij}]_k t_k \quad (53)$$

This matrix is called the extensional stiffness matrix. From the constitutive equation (48), it can be seen that these terms relate the normal stresses and strains (much like the moduli of elasticity), except for the A_{16} and A_{26} terms which relate shear strains to normal stresses and normal strains to shear stresses. Thus, when A_{16} and A_{26} are nonzero, and the laminate has a shear strain applied to it, normal stresses will result and vice-versa. These terms are analogous to the Q_{16} and Q_{26} terms mentioned in the final part of section II.

Equation (46) can be written as:

$$B_{ij} = \frac{1}{2} \sum_{k=1}^n [\bar{Q}_{ij}]_k (h_k - h_{k-1}) (h_k + h_{k-1}) = \sum_{k=1}^n [\bar{Q}_{ij}]_k t_k \frac{(h_k + h_{k-1})}{2}, \quad (54)$$

where t_k is the thickness of the k th ply, and $(h_k + h_{k-1})/2$ is the distance from the geometric midplane to the center of the k th ply. This matrix is called the coupling stiffness matrix. From the constitutive equation (48), it can be seen that these terms relate bending strains (plate curvatures) with normal stresses and vice-versa. The B_{16} and B_{26} terms relate twisting strains to normal stresses and shear strains to bending stresses.

If the laminate is symmetric, then the B_{ij} terms will be the same for each mirrored ply above and below the midplane, with the exception of the sign of the $(h_k + h_{k-1})/2$ term being negative if it is below the midplane ($-z$) and positive if it is above the midplane ($+z$). Thus, when summed, the result will be zero for all B_{ij} . Now define:

$$\frac{(h_k + h_{k-1})}{2} \equiv z_k$$

Part of equation (47) can be written as:

$$\begin{aligned} (h_k^3 - h_{k-1}^3) &= \left[(h_k^2 + h_{k-1}^2) (h_k - h_{k-1}) + h_k^2 h_{k-1} - h_k h_{k-1}^2 \right] \\ &= \left[(h_k - h_{k-1})^3 + 3h_k^2 h_{k-1} - 3h_k h_{k-1}^2 \right] \\ &= \left[(h_k - h_{k-1})^3 + 3(h_k - h_{k-1})(h_k + h_{k-1})^2 - 3(h_k^3 - h_{k-1}^3) \right] \\ &\Rightarrow 4(h_k^3 - h_{k-1}^3) = t_k^3 + 12t_k z_k^2 \end{aligned} \quad (55)$$

Therefore, equation (47) can be written as:

$$D_{ij} = \sum_{k=1}^n [\bar{Q}_{ij}]_k \left(\frac{t_k^3}{12} + t_k z_k \right) . \quad (56)$$

It can be seen that the last term is the second moment of the k th ply with respect to the geometric midplane. D_{ij} is called the bending stiffness matrix and relates the amount of plate curvatures with the bending moments.

IV. NOMENCLATURE FOR DEFINING STACKING SEQUENCES

A. Coordinate System

The choice of coordinate system used for the laminate will determine its stacking sequence. For example, a unidirectional composite can be said to be made up of all 0° plies in the x -direction, and all 90° plies in the y -direction. Alternatively, the same composite can be said to be made up of all 0° plies in the y -direction, and all 90° plies in the x -direction. The composite can also be referenced by any other x - y coordinate system in the plane of the plate. The choice of coordinate system is totally arbitrary, but some general procedures are usually followed to make calculations or communication about the laminate easier for others to understand.

A coordinate system is almost always chosen such that one of the axes runs in the direction of fibers of one of the plies of the laminate. This will make analysis much easier. The x -axis is usually chosen as the "longitudinal" axis, with the corresponding y -axis being the "transverse" direction. This is similar to what was defined earlier for laminae. The main load bearing fibers (if these are known) are usually called the 0° fibers, longitudinal fibers, or x -direction fibers. The other ply orientations will then be defined with this coordinate system. An example of a typical coordinate system is given in figure 11.

B. Nomenclature

There is more than one way to denote the stacking sequence of laminates. However, once one method is learned, any other is easy to interpret, even though it may not be in the form that the user is accustomed to.

Once the 0° fiber direction has been defined (and thus the x -axis), the plies that are not at 0° must be assigned an angle. To do this, start from the x -axis and rotate to the fiber direction of the ply being defined. Clockwise rotations are positive angles, and counterclockwise rotations are negative angles, although the reverse can also be used since only plane-stress is being examined for plates and the material is the same whether viewed from one surface or the other surface. Now that all plies have an angle associated with them, a method of presenting the stacking sequence follows.

If the laminate is symmetric, then start with the angle of the outermost ply and write the ply angles, separated by a comma, until the midplane is reached. Enclose this string of angles in brackets or parentheses and subscript the brackets or parentheses with an "S" to denote "symmetric." If the laminate is not symmetric, then proceed as above until the bottom ply is

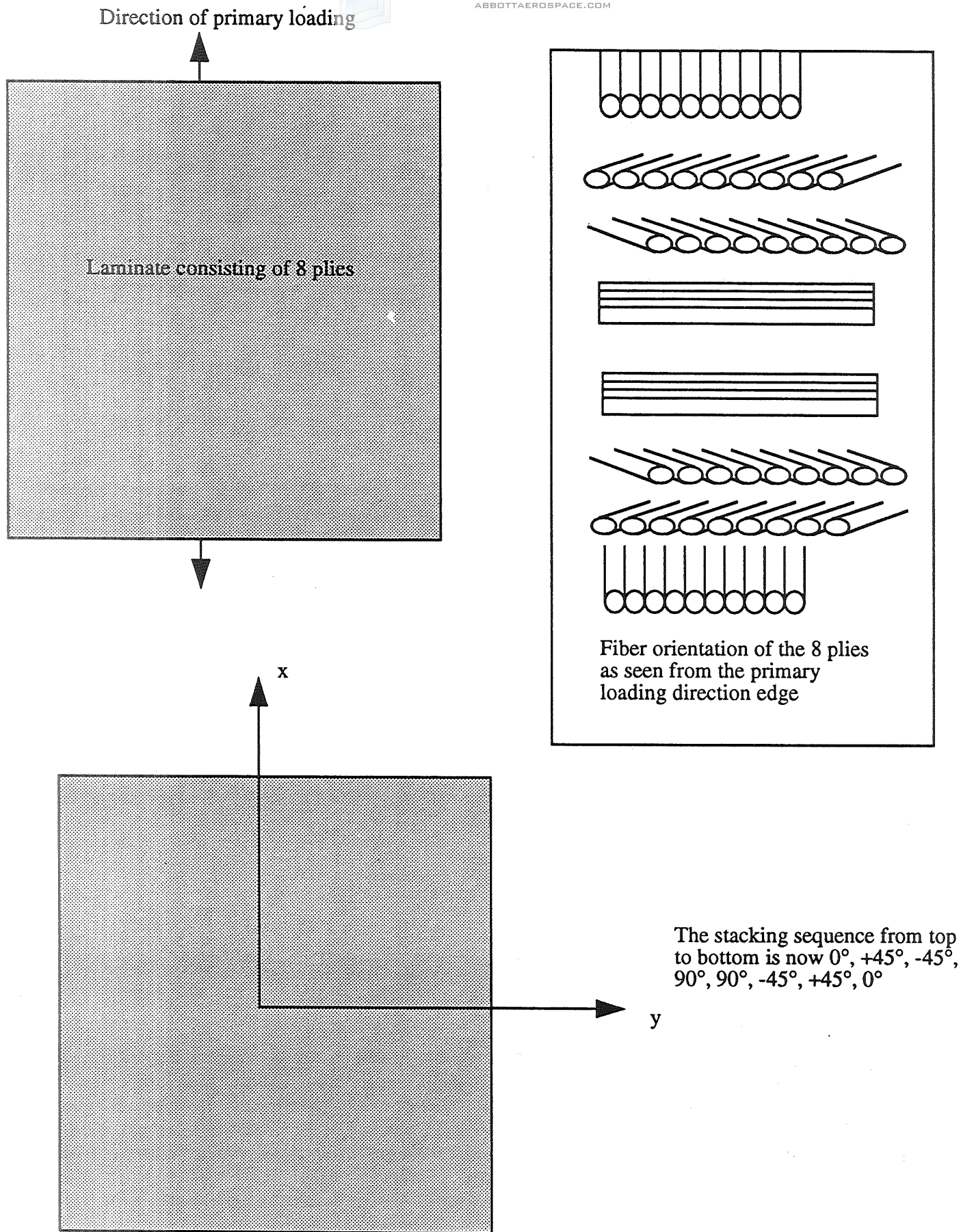

Figure 11. Coordinate system for a typical laminate.

reached. Subscript the brackets or parentheses with a “T” to denote “total” laminate. Referring to figure 10, this laminate is denoted as $[0, +45, -45, 90]_S$. This is more convenient than writing $[0, +45, -45, 90, 90, -45, +45, 0]_T$.

Further simplifications can be made when two or more plies of the same orientation are grouped together. The angle of these plies need only be written once with a subscripted number denoting the number of plies in the group. For example, $[0, 90, 90, 90, 90, 0]_T$ can be written as $[0, 90_4, 0]_T$. Since this laminate is symmetric, further simplifications can result, and this laminate could be described by $[0, 90_2]_S$. If a symmetric laminate consists of an odd number of plies, then the geometrical midplane of the laminate will lie at the midplane of the center ply. In this case, a bar is placed over the angle of this ply to denote that half of it resides in the top half of the laminate and the other half resides in the bottom half of the laminate. For example, a laminate with stacking sequence $[0, 90, 90, 90, 0]_T$ can be written as, $[0, 90, \overline{90}]_S$. Any repeating units within the laminate can be placed in parentheses with a subscripted number representing the number of repeats. For example, a $[0, 90, 0, 90, 0, 90, 0, 90]_S$ laminate can be written as $[(0, 90)_4]_S$. If adjacent plies are of the same angle, but with different signs, then a plus-minus sign is usually placed in front of the angle of the plies. For example, a $[0, +45, -45, 90, +30, -30]_T$ laminate can be written as $[0, \pm 45, 90, \pm 30]_T$. Some examples of stacking sequences and how they can be denoted are given in figure 12.

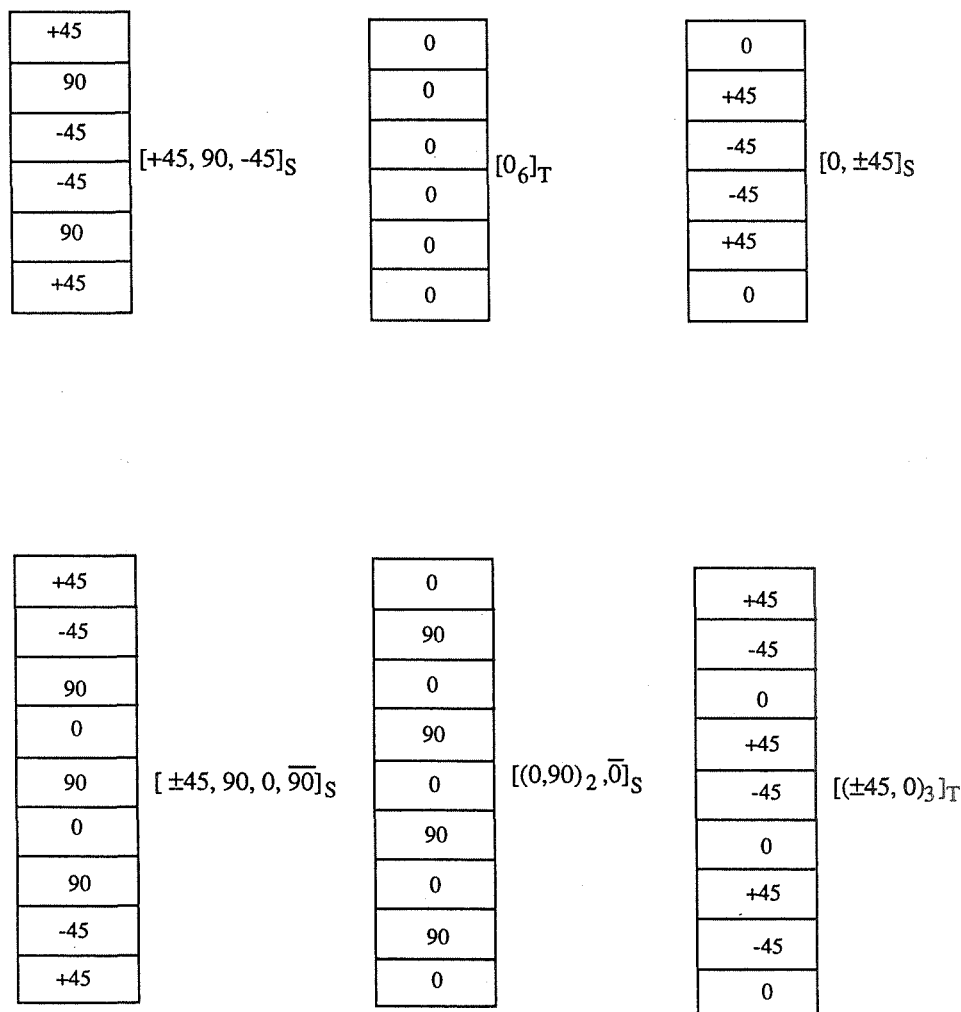

Figure 12. Some laminate stacking sequences and their notation.

V. IN-PLANE ENGINEERING CONSTANTS FOR THE LAMINATE

A. Orientation of the Laminate

For a given stacking sequence of laminae whose engineering properties are known, it is possible to determine the in-plane engineering constants of the laminate from the A_{ij} matrix for symmetric laminates, and the A_{ij} , B_{ij} , and D_{ij} matrices for unsymmetric laminates. The choice of coordinates will determine the directions of the laminate engineering constants being evaluated. These directions are arbitrary, but are usually chosen as described in section IV. A.

B. Symmetric Laminates

Recall that for symmetric laminates, the B_{ij} matrix consists of all elements being zero. This greatly simplifies finding the in-plane engineering constants of the laminate. To find the x -direction modulus, the value of the x -direction stress to the x -direction strain must be calculated. In equation form:

$$E_x = \frac{\sigma_x}{\epsilon_x} = \frac{N_x/h}{\epsilon_x} \quad , \quad (57)$$

where h is the thickness of the laminate. Since the B_{ij} 's are zero, the constitutive equations are:

$$\begin{bmatrix} N_x \\ N_y \\ N_{xy} \end{bmatrix} = \begin{bmatrix} A_{11} & A_{12} & A_{16} \\ A_{12} & A_{22} & A_{26} \\ A_{16} & A_{26} & A_{66} \end{bmatrix} \begin{bmatrix} \epsilon_x^0 \\ \epsilon_y^0 \\ \gamma_{xy}^0 \end{bmatrix} \quad . \quad (58)$$

Since a relationship between N_x and ϵ_x are being sought, when a load is applied in the x -direction, from equation (58):

$$N_x = A_{11}\epsilon_x^0 + A_{12}\epsilon_y^0 + A_{16}\gamma_{xy}^0 \quad , \quad (59)$$

$$0 = A_{12}\epsilon_x^0 + A_{22}\epsilon_y^0 + A_{26}\gamma_{xy}^0 \quad , \quad (60)$$

$$0 = A_{16}\epsilon_x^0 + A_{26}\epsilon_y^0 + A_{66}\gamma_{xy}^0 \quad . \quad (61)$$

From equations (60) and (61):

$$\epsilon_y^0 = \epsilon_x^0 \left(\frac{A_{26}A_{16} - A_{12}A_{66}}{A_{22}A_{66} - A_{26}^2} \right) \quad , \quad (62)$$

and

$$\gamma_{xy}^0 = \varepsilon_x^0 \left(\frac{-A_{16}}{A_{66}} + \frac{A_{26}A_{12}A_{66} - A_{26}^2A_{16}}{A_{22}A_{66}^2 - A_{26}^2A_{66}} \right) . \quad (63)$$

Equations (62) and (63) can be substituted into equation (59) with the result:

$$\frac{N_x}{\varepsilon_x^0} = A_{11} + A_{12} \left(\frac{A_{26}A_{16} - A_{12}A_{66}}{A_{22}A_{66} - A_{26}^2} \right) + A_{16} \left(\frac{-A_{16}}{A_{66}} + \frac{A_{26}A_{12}A_{66} - A_{26}^2A_{16}}{A_{22}A_{66}^2 - A_{26}^2A_{66}} \right) . \quad (64)$$

Thus, E_x can be calculated by dividing equation (64) by the thickness of the laminate, h which will give equation (57).

The same procedure is followed to obtain E_y . The constitutive equations are:

$$0 = A_{11}\varepsilon_x^0 + A_{12}\varepsilon_y^0 + A_{16}\gamma_{xy}^0 , \quad (65)$$

$$N_y = A_{12}\varepsilon_x^0 + A_{22}\varepsilon_y^0 + A_{26}\gamma_{xy}^0 , \quad (66)$$

$$0 = A_{16}\varepsilon_x^0 + A_{26}\varepsilon_y^0 + A_{66}\gamma_{xy}^0 . \quad (67)$$

From equations (65) and (67):

$$\varepsilon_x^0 = \varepsilon_y^0 \left(\frac{A_{16}A_{26} - A_{12}A_{66}}{A_{11}A_{66} - A_{16}^2} \right) , \quad (68)$$

and

$$\gamma_{xy}^0 = \varepsilon_y^0 \left(\frac{-A_{26}}{A_{66}} + \frac{A_{16}A_{12}A_{66} - A_{16}^2A_{26}}{A_{11}A_{66}^2 - A_{16}^2A_{66}} \right) . \quad (69)$$

Equations (68) and (69) can be substituted into equation (66) with the result:

$$\frac{N_y}{\varepsilon_y^0} = A_{12} \left(\frac{A_{16}A_{26} - A_{12}A_{66}}{A_{11}A_{66} - A_{16}^2} \right) + A_{22} + A_{26} \left(\frac{-A_{26}}{A_{66}} + \frac{A_{16}A_{12}A_{66} - A_{16}^2A_{26}}{A_{11}A_{66}^2 - A_{16}^2A_{66}} \right) . \quad (70)$$

Dividing equation (70) by the laminate thickness will give E_y .

G_{xy} is found in the same manner. The constitutive equations are:

$$0 = A_{11}\epsilon_x^0 + A_{12}\epsilon_y^0 + A_{16}\gamma_{xy}^0, \quad (71)$$

$$0 = A_{12}\epsilon_x^0 + A_{22}\epsilon_y^0 + A_{26}\gamma_{xy}^0, \quad (72)$$

$$N_{xy} = A_{16}\epsilon_x^0 + A_{26}\epsilon_y^0 + A_{66}\gamma_{xy}^0. \quad (73)$$

From equations (71) and (72):

$$\epsilon_x^0 = \gamma_{xy}^0 \left(\frac{A_{12}A_{26} - A_{16}A_{22}}{A_{11}A_{22} - A_{12}^2} \right), \quad (74)$$

and

$$\epsilon_y^0 = \gamma_{xy}^0 \left(\frac{-A_{26}}{A_{22}} + \frac{A_{16}A_{12}A_{22} - A_{12}^2A_{26}}{A_{11}A_{22}^2 - A_{12}^2A_{22}} \right). \quad (75)$$

Equations (74) and (75) can be used with equation(73) to obtain:

$$\frac{N_{xy}}{\gamma_{xy}^0} = A_{66} - \frac{A_{26}^2}{A_{22}} + \frac{2A_{12}A_{16}A_{26}A_{22} - A_{12}^2A_{26}^2 - A_{16}^2A_{22}^2}{A_{11}A_{22}^2 - A_{12}^2A_{22}}. \quad (76)$$

Dividing equation (76) by the laminate thickness will give G_{xy} .

To find Poisson's ratio of the laminate, use equations (60) and (61) to obtain:

$$0 = A_{12}\epsilon_x^0 + A_{22}\epsilon_y^0 + A_{26} \left(-\frac{A_{16}}{A_{66}}\epsilon_x^0 - \frac{A_{26}}{A_{66}}\epsilon_y^0 \right). \quad (77)$$

Rearranging to get:

$$\nu_{xy} = \frac{-\epsilon_y^0}{\epsilon_x^0} = \frac{\left(A_{12} - \frac{A_{16}A_{26}}{A_{66}} \right)}{\left(A_{22} - \frac{A_{26}^2}{A_{66}} \right)}. \quad (78)$$

Using equations (65) and (67):

$$0 = A_{11}\epsilon_x^0 + A_{12}\epsilon_y^0 + A_{16}\left(-\frac{A_{16}}{A_{66}}\epsilon_x^0 - \frac{A_{26}}{A_{66}}\epsilon_y^0\right) \quad (79)$$

Rearranging to get:

$$\nu_{yx} = \frac{-\epsilon_x^0}{\epsilon_y^0} = \frac{\left(\frac{A_{16}A_{26}}{A_{66}} - A_{12}\right)}{\left(\frac{A_{16}^2}{A_{66}} - A_{11}\right)} \quad (80)$$

Example 1:

Suppose a 4-ply laminate of AS4/3501-6 is laid up in a $[0,+45]_S$ stacking sequence. The ply properties are given below for this material:

$$E_1 = 20,010,000 \text{ lb/in}^2 \quad ,$$

$$E_2 = 1,301,000 \text{ lb/in}^2 \quad ,$$

$$G_{12} = 1,001,000 \text{ lb/in}^2 \quad ,$$

$$\nu_{12} = 0.3 \quad ,$$

$$\nu_{21} = 0.02 \quad ,$$

$$\text{Ply thickness} = 0.005 \text{ in} \quad .$$

This is all of the information needed to calculate the in-plane engineering constants. Calculating E_x will demonstrate the general procedure applied to any of the engineering constants. From equation (10):

$$\begin{aligned} Q_{11} &= \frac{E_1}{1-\nu_{12}\nu_{21}} = \frac{20,010,000 \text{ lb/in}^2}{1-(0.3)(0.02)} = 20,130,785 \text{ lb/in}^2 \quad , \\ Q_{22} &= \frac{E_2}{1-\nu_{12}\nu_{21}} = \frac{1,301,000 \text{ lb/in}^2}{1-(0.3)(0.02)} = 1,308,853 \text{ lb/in}^2 \quad , \\ Q_{12} &= \frac{\nu_{12}E_2}{1-\nu_{12}\nu_{21}} = \frac{(0.3)(1,301,000 \text{ lb/in}^2)}{1-(0.3)(0.02)} = 392,656 \text{ lb/in}^2 \quad , \\ Q_{66} &= 1,001,000 \text{ lb/in}^2 \quad . \end{aligned} \quad (E1.1)$$

From equation (22), for the 0° plies:

$$\begin{aligned}
 \bar{Q}_{11}^0 &= 20,130,785 \text{ lb/in}^2 , \\
 \bar{Q}_{12}^0 &= 392,656 \text{ lb/in}^2 , \\
 \bar{Q}_{22}^0 &= 1,308,853 \text{ lb/in}^2 , \\
 \bar{Q}_{16}^0 &= 0 , \\
 \bar{Q}_{26}^0 &= 0 , \\
 \bar{Q}_{66}^0 &= 1,001,000 \text{ lb/in}^2 .
 \end{aligned} \tag{E1.2}$$

For the +45° plies:

$$\begin{aligned}
 \bar{Q}_{11}^{+45} &= (20,130,785 \text{ lb/in}^2)(0.707)^4 + 2 \left((392,656 \text{ lb/in}^2 + 2(1,001,000 \text{ lb/in}^2)) \right) (0.707)^2 (0.707)^2 \\
 &\quad + (1,308,853 \text{ lb/in}^2)(0.707)^4 = 6,557,237 \text{ lb/in}^2 , \\
 \bar{Q}_{12}^{+45} &= \left((20,130,785 \text{ lb/in}^2 + 1,308,853 \text{ lb/in}^2 - 4(1,001,000 \text{ lb/in}^2)) \right) (0.707)^2 (0.707)^2 \\
 &\quad + 392,656 \text{ lb/in}^2 \left((0.707)^4 + (0.707)^4 \right) = 4,555,238 \text{ lb/in}^2 , \\
 \bar{Q}_{22}^{+45} &= (20,130,785 \text{ lb/in}^2)(0.707)^4 + 2 \left((392,656 \text{ lb/in}^2 + 2(1,001,000 \text{ lb/in}^2)) \right) (0.707)^2 (0.707)^2 \\
 &\quad + (1,308,853 \text{ lb/in}^2)(0.707)^4 = 6,557,237 \text{ lb/in}^2 , \\
 \bar{Q}_{16}^{+45} &= \left(20,130,785 \text{ lb/in}^2 - 392,656 \text{ lb/in}^2 - 2(1,001,000 \text{ lb/in}^2) \right) (0.707)^3 (0.707) \\
 &\quad + \left(392,656 \text{ lb/in}^2 - 1,308,853 \text{ lb/in}^2 + 2(1,001,000 \text{ lb/in}^2) \right) (0.707)(0.707)^3 = 4,705,483 \text{ lb/in}^2 , \\
 \bar{Q}_{26}^{+45} &= \left(20,130,785 \text{ lb/in}^2 - 392,656 \text{ lb/in}^2 - 2(1,001,000 \text{ lb/in}^2) \right) (0.707)^3 (0.707) \\
 &\quad + \left(392,656 \text{ lb/in}^2 - 1,308,853 \text{ lb/in}^2 + 2(1,001,000 \text{ lb/in}^2) \right) (0.707)(0.707)^3 = 4,705,483 \text{ lb/in}^2 , \\
 \bar{Q}_{66}^{+45} &= \left(20,130,785 \text{ lb/in}^2 + 1,308,853 \text{ lb/in}^2 - 2(392,656 \text{ lb/in}^2 + 1,001,000 \text{ lb/in}^2) \right) (0.707)^2 (0.707)^2 \\
 &\quad + 1,001,000 \text{ lb/in}^2 \left((0.707)^4 + (0.707)^4 \right) = 5,163,582 \text{ lb/in}^2 .
 \end{aligned} \tag{E1.3}$$

Now from equation (53), the A_{ij} are obtained:

$$\begin{aligned}
 A_{11} &= [20,130,785+6,557,237+20,130,785+6,557,237]\text{lb/in}^2 (0.005 \text{ in}) = 266,880 \frac{\text{lb}}{\text{in}}, \\
 A_{12} &= [392,656+4,555,238+392,656+4,555,238]\text{lb/in}^2 (0.005 \text{ in}) = 49,479 \frac{\text{lb}}{\text{in}}, \\
 A_{22} &= [1,308,853+6,557,237+1,308,853+6,557,237]\text{lb/in}^2 (0.005 \text{ in}) = 78,661 \frac{\text{lb}}{\text{in}}, \\
 A_{16} &= [0+4,705,483+0+4,705,483]\text{lb/in}^2 (0.005 \text{ in}) = 47,055 \frac{\text{lb}}{\text{in}}, \\
 A_{26} &= [0+4,705,483+0+4,705,483]\text{lb/in}^2 (0.005 \text{ in}) = 47,055 \frac{\text{lb}}{\text{in}}, \\
 A_{66} &= [1,001,000+5,163,582+1,001,000+5,163,582]\text{lb/in}^2 (0.005 \text{ in}) = 61,646 \frac{\text{lb}}{\text{in}}.
 \end{aligned} \tag{E1.4}$$

From equations (64) and (57):

$$\begin{aligned}
 E_x &= \frac{266,880 \frac{\text{lb}}{\text{in}}}{0.02 \text{ in}} + (49,479) \left(\frac{(47,055)(47,055) - (49,479)(61,646)}{(78,661)(61,646) - (47,055)^2} \right) \frac{\text{lb}}{\text{in}} \\
 &\quad + (47,055) \left(\frac{- (47,055)}{(61,646)} + \left(\frac{(47,055)(49,479)(61,646) - (47,055)^2(47,055)}{(78,661)(61,646)^2 - (47,055)^2(61,646)} \right) \right) \frac{\text{lb}}{\text{in}} \\
 &\quad \cdot 0.02 \text{ in} \\
 E_x &= 11,333,000 \text{ lb/in}^2
 \end{aligned} \tag{E1.5}$$

C. Nonsymmetric Laminates

Since for a nonsymmetric laminate there are nonzero B_{ij} terms, the calculation of in-plane engineering constants become more involved; however, the same basic procedure is followed as for symmetric laminates. Since there are now six equations instead of three, it will be much easier to use matrix notation. The constitutive equations are given by equation (48):

$$\begin{bmatrix} N_x \\ N_y \\ N_{xy} \\ \hline M_x \\ M_y \\ M_{xy} \end{bmatrix} = \left[\begin{array}{ccc|ccc} A_{11} & A_{12} & A_{16} & B_{11} & B_{12} & B_{16} \\ A_{12} & A_{22} & A_{26} & B_{12} & B_{22} & B_{26} \\ A_{16} & A_{26} & A_{66} & B_{16} & B_{26} & B_{66} \\ \hline B_{11} & B_{12} & B_{16} & D_{11} & D_{12} & D_{16} \\ B_{12} & B_{22} & B_{26} & D_{12} & D_{22} & D_{26} \\ B_{16} & B_{26} & B_{66} & D_{16} & D_{26} & D_{66} \end{array} \right] \begin{bmatrix} \epsilon_x^0 \\ \epsilon_y^0 \\ \gamma_{xy}^0 \\ \hline K_x \\ K_y \\ K_{xy} \end{bmatrix} \quad (48)$$

To find E_x , only the x -direction in-plane load is applied and a relationship between N_x and ϵ_x^0 is sought. The constitutive equation now becomes:

$$\begin{bmatrix} N_x \\ 0 \\ 0 \\ \hline 0 \\ 0 \\ 0 \end{bmatrix} = \left[\begin{array}{ccc|ccc} A_{11} & A_{12} & A_{16} & B_{11} & B_{12} & B_{16} \\ A_{12} & A_{22} & A_{26} & B_{12} & B_{22} & B_{26} \\ A_{16} & A_{26} & A_{66} & B_{16} & B_{26} & B_{66} \\ \hline B_{11} & B_{12} & B_{16} & D_{11} & D_{12} & D_{16} \\ B_{12} & B_{22} & B_{26} & D_{12} & D_{22} & D_{26} \\ B_{16} & B_{26} & B_{66} & D_{16} & D_{26} & D_{66} \end{array} \right] \begin{bmatrix} \epsilon_x^0 \\ \epsilon_y^0 \\ \gamma_{xy}^0 \\ \hline K_x \\ K_y \\ K_{xy} \end{bmatrix} \quad (81)$$

Using Cramer's rule to solve for ϵ_x^0 :

$$\epsilon_x^0 = \frac{\begin{vmatrix} N_x & A_{12} & A_{16} & B_{11} & B_{12} & B_{16} \\ 0 & A_{22} & A_{26} & B_{12} & B_{22} & B_{26} \\ 0 & A_{26} & A_{66} & B_{16} & B_{26} & B_{66} \\ 0 & B_{12} & B_{16} & D_{11} & D_{12} & D_{16} \\ 0 & B_{22} & B_{26} & D_{12} & D_{22} & D_{26} \\ 0 & B_{26} & B_{66} & D_{16} & D_{26} & D_{66} \end{vmatrix}}{\begin{vmatrix} A_{11} & A_{12} & A_{16} & B_{11} & B_{12} & B_{16} \\ A_{12} & A_{22} & A_{26} & B_{12} & B_{22} & B_{26} \\ A_{16} & A_{26} & A_{66} & B_{16} & B_{26} & B_{66} \\ B_{11} & B_{12} & B_{16} & D_{11} & D_{12} & D_{16} \\ B_{12} & B_{22} & B_{26} & D_{12} & D_{22} & D_{26} \\ B_{16} & B_{26} & B_{66} & D_{16} & D_{26} & D_{66} \end{vmatrix}} \quad (82)$$

Determinants for two 6x6 matrices must be found.

At this point, it should be clear why a computer (or calculator) program makes calculations much easier. To write out the solution for equation (82) would require $6! = 720$ terms for the numerator and the denominator. Cofactor expansion can be used in the numerator for some simplification:

$$\varepsilon_x^0 = \frac{N_x}{\begin{vmatrix} A_{11} A_{12} A_{16} & B_{11} B_{12} B_{16} \\ A_{12} A_{22} A_{26} & B_{12} B_{22} B_{26} \\ A_{16} A_{26} A_{66} & B_{16} B_{26} B_{66} \\ B_{11} B_{12} B_{16} & D_{11} D_{12} D_{16} \\ B_{12} B_{22} B_{26} & D_{12} D_{22} D_{26} \\ B_{16} B_{26} B_{66} & D_{16} D_{26} D_{66} \end{vmatrix}} \quad (83)$$

From equation (57), E_x can be found by evaluating:

$$\frac{N_x/h}{\varepsilon_x^0} = E_x = \frac{1}{h} \begin{vmatrix} A_{11} A_{12} A_{16} & B_{11} B_{12} B_{16} \\ A_{12} A_{22} A_{26} & B_{12} B_{22} B_{26} \\ A_{16} A_{26} A_{66} & B_{16} B_{26} B_{66} \\ B_{11} B_{12} B_{16} & D_{11} D_{12} D_{16} \\ B_{12} B_{22} B_{26} & D_{12} D_{22} D_{26} \\ B_{16} B_{26} B_{66} & D_{16} D_{26} D_{66} \end{vmatrix} \quad (84)$$

Appendix A shows a Fortran program to calculate the determinant of a 6x6 and 5x5 matrix.

E_y can be found in a similar manner. The denominator will be different since equation (81) is being solved for ϵ_x^0 .

$$\frac{N_y/h}{\epsilon_y^0} = E_y = \frac{\begin{vmatrix} A_{11}A_{12}A_{16} & B_{11}B_{12}B_{16} \\ A_{12}A_{22}A_{26} & B_{12}B_{22}B_{26} \\ A_{16}A_{26}A_{66} & B_{16}B_{26}B_{66} \\ B_{11}B_{12}B_{16} & D_{11}D_{12}D_{16} \\ B_{12}B_{22}B_{26} & D_{12}D_{22}D_{26} \\ B_{16}B_{26}B_{66} & D_{16}D_{26}D_{66} \end{vmatrix}}{\begin{vmatrix} A_{11} & A_{16} & B_{11} & B_{12} & B_{16} \\ A_{16} & A_{66} & B_{16} & B_{26} & B_{66} \\ B_{11} & B_{16} & D_{11} & D_{12} & D_{16} \\ B_{12} & B_{26} & D_{12} & D_{22} & D_{26} \\ B_{16} & B_{66} & D_{16} & D_{26} & D_{66} \end{vmatrix}} \cdot \frac{1}{h} \quad (85)$$

G_{xy} will be given by:

$$\frac{N_{xy}/h}{\gamma_{xy}^0} = G_{xy} = \frac{\begin{vmatrix} A_{11}A_{12}A_{16} & B_{11}B_{12}B_{16} \\ A_{12}A_{22}A_{26} & B_{12}B_{22}B_{26} \\ A_{16}A_{26}A_{66} & B_{16}B_{26}B_{66} \\ B_{11}B_{12}B_{16} & D_{11}D_{12}D_{16} \\ B_{12}B_{22}B_{26} & D_{12}D_{22}D_{26} \\ B_{16}B_{26}B_{66} & D_{16}D_{26}D_{66} \end{vmatrix}}{\begin{vmatrix} A_{11} & A_{12} & B_{11} & B_{12} & B_{16} \\ A_{12} & A_{22} & B_{12} & B_{22} & B_{26} \\ B_{11} & B_{12} & D_{11} & D_{12} & D_{16} \\ B_{12} & B_{22} & D_{12} & D_{22} & D_{26} \\ B_{16} & B_{26} & D_{16} & D_{26} & D_{66} \end{vmatrix}} \cdot \frac{1}{h} \quad (86)$$

Poisson's ratio will be determined as it was for symmetric laminates. For v_{xy} , the contraction in the y -direction upon an applied stress in the x -direction must be obtained. This is given by:

$$\varepsilon_y^0 = \frac{-N_x \begin{vmatrix} A_{12} & A_{26} & B_{12} & B_{22} & B_{26} \\ A_{16} & A_{66} & B_{16} & B_{26} & B_{66} \\ B_{11} & B_{16} & D_{11} & D_{12} & D_{16} \\ B_{12} & B_{26} & D_{12} & D_{22} & D_{26} \\ B_{16} & B_{66} & D_{16} & D_{26} & D_{66} \end{vmatrix}}{\begin{vmatrix} A_{11} & A_{12} & A_{16} & B_{11} & B_{12} & B_{16} \\ A_{12} & A_{22} & A_{26} & B_{12} & B_{22} & B_{26} \\ A_{16} & A_{26} & A_{66} & B_{16} & B_{26} & B_{66} \\ B_{11} & B_{12} & B_{16} & D_{11} & D_{12} & D_{16} \\ B_{12} & B_{22} & B_{26} & D_{12} & D_{22} & D_{26} \\ B_{16} & B_{26} & B_{66} & D_{16} & D_{26} & D_{66} \end{vmatrix}}$$
(87)

Thus, v_{xy} will be given by:

$$v_{xy} = \frac{-\varepsilon_y^0}{\varepsilon_x^0} = \frac{- \begin{vmatrix} A_{12} & A_{26} & B_{12} & B_{22} & B_{26} \\ A_{16} & A_{66} & B_{16} & B_{26} & B_{66} \\ B_{11} & B_{16} & D_{11} & D_{12} & D_{16} \\ B_{12} & B_{26} & D_{12} & D_{22} & D_{26} \\ B_{16} & B_{66} & D_{16} & D_{26} & D_{66} \end{vmatrix}}{\begin{vmatrix} A_{22} & A_{26} & B_{12} & B_{22} & B_{26} \\ A_{26} & A_{66} & B_{16} & B_{26} & B_{66} \\ B_{12} & B_{16} & D_{11} & D_{12} & D_{16} \\ B_{22} & B_{26} & D_{12} & D_{22} & D_{26} \\ B_{26} & B_{66} & D_{16} & D_{26} & D_{66} \end{vmatrix}}$$
(88)

v_{yx} is given by:

$$v_{yx} = \frac{-\epsilon_x^0}{\epsilon_y^0} = \frac{-\begin{vmatrix} A_{12} & A_{16} & B_{11} & B_{12} & B_{16} \\ A_{16} & A_{66} & B_{16} & B_{26} & B_{66} \\ B_{12} & B_{16} & D_{11} & D_{12} & D_{16} \\ B_{22} & B_{26} & D_{12} & D_{22} & D_{26} \\ B_{16} & B_{66} & D_{16} & D_{26} & D_{66} \end{vmatrix}}{\begin{vmatrix} A_{11} & A_{16} & B_{12} & B_{22} & B_{26} \\ A_{16} & A_{66} & B_{16} & B_{26} & B_{66} \\ B_{11} & B_{16} & D_{11} & D_{12} & D_{16} \\ B_{12} & B_{26} & D_{12} & D_{22} & D_{26} \\ B_{16} & B_{66} & D_{16} & D_{26} & D_{66} \end{vmatrix}} \quad (89)$$

Example 2:

Given a 2-ply laminate of stacking sequence $[0,+45]_T$, E_x will be calculated. From example 1, the A_{ij} 's are known. The B_{ij} 's and D_{ij} 's must be calculated.

To obtain the B_{ij} , use equation (54) with the already determined values in equations (E1.2) and (E1.3).

$$\begin{aligned} B_{11} &= 20,130,755 \text{ lb/in}^2 (0.005 \text{ in})(0.0025 \text{ in}) \\ &\quad + 6,557,237 \text{ lb/in}^2 (0.005 \text{ in})(-0.0025 \text{ in}) = 170 \text{ lb} , \\ B_{12} &= 392,656 \text{ lb/in}^2 (0.005 \text{ in})(0.0025 \text{ in}) \\ &\quad + 4,555,238 \text{ lb/in}^2 (0.005 \text{ in})(0.0025 \text{ in}) = -52 \text{ lb} , \\ B_{22} &= 1,308,853 \text{ lb/in}^2 (0.005 \text{ in})(0.0025 \text{ in}) \\ &\quad + 6,557,237 \text{ lb/in}^2 (0.005 \text{ in})(-0.0025 \text{ in}) = -66 \text{ lb} \\ B_{16} &= 0 + 4,705,483 \text{ lb/in}^2 (0.005 \text{ in})(-0.0025 \text{ in}) = -59 \text{ lb} , \\ B_{26} &= 0 + 4,705,483 \text{ lb/in}^2 (0.005 \text{ in})(-0.0025 \text{ in}) = -59 \text{ lb} , \\ B_{66} &= 1,001,000 \text{ lb/in}^2 (0.005 \text{ in})(0.0025 \text{ in}) \\ &\quad + 5,163,582 \text{ lb/in}^2 (0.005 \text{ in})(-0.0025 \text{ in}) = -52 \text{ lb} . \end{aligned} \quad (E2.1)$$

Use equation (56) to find the D_{ij} 's:

$$\begin{aligned}
 D_{11} &= 20,130,785 \text{ lb/in}^2 \left(\frac{(0.005)^3}{12} + (0.005)(0.0025)^2 \right) \text{in}^3 \\
 &\quad + 6,557,237 \text{ lb/in}^2 \left(\frac{(0.005)^3}{12} + (0.005)(-0.0025)^2 \right) \text{in}^3 = 1.112 \text{ in-lb} , \\
 D_{12} &= 392,656 \text{ lb/in}^2 \left(\frac{(0.005)^3}{12} + (0.005)(0.0025)^2 \right) \text{in}^3 \\
 &\quad + 4,555,238 \text{ lb/in}^2 \left(\frac{(0.005)^3}{12} + (0.005)(-0.0025)^2 \right) \text{in}^3 = 0.206 \text{ in-lb} , \\
 D_{22} &= 1,308,853 \text{ lb/in}^2 \left(\frac{(0.005)^3}{12} + (0.005)(0.0025)^2 \right) \text{in}^3 \\
 &\quad + 6,557,237 \text{ lb/in}^2 \left(\frac{(0.005)^3}{12} + (0.005)(-0.0025)^2 \right) \text{in}^3 = 0.328 \text{ in-lb} , \\
 D_{16} &= 0 + 4,705,483 \text{ lb/in}^2 \left(\frac{(0.005)^3}{12} + (0.005)(-0.0025)^2 \right) \text{in}^3 = 0.196 \text{ in-lb} , \\
 D_{26} &= 0 + 4,705,483 \text{ lb/in}^2 \left(\frac{(0.005)^3}{12} + (0.005)(-0.0025)^2 \right) \text{in}^3 = 0.196 \text{ in-lb} , \\
 D_{66} &= 1,001,000 \text{ lb/in}^2 \left(\frac{(0.005)^3}{12} + (0.005)(0.0025)^2 \right) \text{in}^3 \\
 &\quad + 5,163,582 \text{ lb/in}^2 \left(\frac{(0.005)^3}{12} + (0.005)(-0.0025)^2 \right) \text{in}^3 = 0.257 \text{ in-lb} .
 \end{aligned} \tag{E2.2}$$

Now use equation (84) and the Fortran programs in appendix A to obtain:

$$\frac{N_x/h}{\epsilon_x^0} = E_x = \frac{8.43 \times 10^{11} \text{ lb}^6}{14,440,750 \text{ lb}^5\text{-in}} \frac{1}{0.01 \text{ in}} = 5,839,000 \text{ lb/in}^2 . \tag{E2.3}$$

D. Summary

The equations for the in-plane engineering constants of a symmetric laminate are:

$$E_x = \frac{A_{11}}{h} + \frac{A_{12}}{h} \left(\frac{A_{26}A_{16} - A_{12}A_{66}}{A_{22}A_{66} - A_{26}^2} \right) + \frac{A_{16}}{h} \left(\frac{-A_{16}}{A_{66}} + \frac{A_{26}A_{12}A_{66} - A_{26}^2A_{16}}{A_{22}A_{66}^2 - A_{26}^2A_{66}} \right),$$

$$E_y = \frac{A_{22}}{h} + \frac{A_{12}}{h} \left(\frac{A_{26}A_{16} - A_{12}A_{66}}{A_{11}A_{66} - A_{16}^2} \right) + \frac{A_{26}}{h} \left(\frac{-A_{26}}{A_{66}} + \frac{A_{16}A_{12}A_{66} - A_{16}^2A_{26}}{A_{11}A_{66}^2 - A_{16}^2A_{66}} \right),$$

$$G_{xy} = \frac{A_{66}}{h} - \frac{A_{26}^2}{hA_{22}} + \frac{2A_{16}A_{12}A_{22}A_{26} - A_{12}^2A_{26}^2 - A_{16}^2A_{22}^2}{h(A_{11}A_{22}^2 - A_{12}^2A_{22})},$$

$$v_{xy} = \frac{\left(A_{12} - \frac{A_{16}A_{26}}{A_{66}} \right)}{\left(A_{22} - \frac{A_{26}^2}{A_{66}} \right)},$$

$$v_{yx} = \frac{\left(\frac{A_{16}A_{26}}{A_{66}} - A_{12} \right)}{\left(\frac{A_{16}^2}{A_{66}} - A_{11} \right)}.$$

For unsymmetric laminates, the engineering constants are given by:

$$E_x = \frac{1}{h} \begin{vmatrix} A_{11} & A_{12} & A_{16} & B_{11} & B_{12} & B_{16} \\ A_{12} & A_{22} & A_{26} & B_{12} & B_{22} & B_{26} \\ A_{16} & A_{26} & A_{66} & B_{16} & B_{26} & B_{66} \\ B_{11} & B_{12} & B_{16} & D_{11} & D_{12} & D_{16} \\ B_{12} & B_{22} & B_{26} & D_{12} & D_{22} & D_{26} \\ B_{16} & B_{26} & B_{66} & D_{16} & D_{26} & D_{66} \end{vmatrix} \begin{vmatrix} A_{22} & A_{26} & B_{12} & B_{22} & B_{26} \\ A_{26} & A_{66} & B_{16} & B_{26} & B_{66} \\ B_{12} & B_{16} & D_{11} & D_{12} & D_{16} \\ B_{22} & B_{26} & D_{12} & D_{22} & D_{26} \\ B_{26} & B_{66} & D_{16} & D_{26} & D_{66} \end{vmatrix} ,$$

$$E_y = \frac{1}{h} \begin{vmatrix} A_{11} & A_{12} & A_{16} & B_{11} & B_{12} & B_{16} \\ A_{12} & A_{22} & A_{26} & B_{12} & B_{22} & B_{26} \\ A_{16} & A_{26} & A_{66} & B_{16} & B_{26} & B_{66} \\ B_{11} & B_{12} & B_{16} & D_{11} & D_{12} & D_{16} \\ B_{12} & B_{22} & B_{26} & D_{12} & D_{22} & D_{26} \\ B_{16} & B_{26} & B_{66} & D_{16} & D_{26} & D_{66} \end{vmatrix} \begin{vmatrix} A_{11} & A_{16} & B_{11} & B_{12} & B_{16} \\ A_{16} & A_{66} & B_{16} & B_{26} & B_{66} \\ B_{11} & B_{16} & D_{11} & D_{12} & D_{16} \\ B_{12} & B_{26} & D_{12} & D_{22} & D_{26} \\ B_{16} & B_{66} & D_{16} & D_{26} & D_{66} \end{vmatrix} ,$$

$$G_{xy} = \frac{1}{h} \begin{matrix} \begin{matrix} A_{11} & A_{12} & A_{16} & B_{11} & B_{12} & B_{16} \\ A_{12} & A_{22} & A_{26} & B_{12} & B_{22} & B_{26} \\ A_{16} & A_{26} & A_{66} & B_{16} & B_{26} & B_{66} \\ B_{11} & B_{12} & B_{16} & D_{11} & D_{12} & D_{16} \\ B_{12} & B_{22} & B_{26} & D_{12} & D_{22} & D_{26} \\ B_{16} & B_{26} & B_{66} & D_{16} & D_{26} & D_{66} \end{matrix} \\ \begin{matrix} A_{11} & A_{12} & B_{11} & B_{12} & B_{16} \\ A_{12} & A_{22} & B_{12} & B_{22} & B_{26} \\ B_{11} & B_{12} & D_{11} & D_{12} & D_{16} \\ B_{12} & B_{22} & D_{12} & D_{22} & D_{26} \\ B_{16} & B_{26} & D_{16} & D_{26} & D_{66} \end{matrix} \\ - \begin{matrix} A_{12} & A_{26} & B_{12} & B_{22} & B_{26} \\ A_{16} & A_{66} & B_{16} & B_{26} & B_{66} \\ B_{11} & B_{16} & D_{11} & D_{12} & D_{16} \\ B_{12} & B_{26} & D_{12} & D_{22} & D_{26} \\ B_{16} & B_{66} & D_{16} & D_{26} & D_{66} \end{matrix} \\ \begin{matrix} A_{22} & A_{26} & B_{12} & B_{22} & B_{26} \\ A_{26} & A_{66} & B_{16} & B_{26} & B_{66} \\ B_{12} & B_{16} & D_{11} & D_{12} & D_{16} \\ B_{22} & B_{26} & D_{12} & D_{22} & D_{26} \\ B_{26} & B_{66} & D_{16} & D_{26} & D_{66} \end{matrix} \end{matrix} ,$$

$$v_{yx} = \frac{\begin{matrix} A_{12} & A_{16} & B_{11} & B_{12} & B_{16} \\ A_{16} & A_{66} & B_{16} & B_{26} & B_{66} \\ B_{12} & B_{16} & D_{11} & D_{12} & D_{16} \\ B_{22} & B_{26} & D_{12} & D_{22} & D_{26} \\ B_{16} & B_{66} & D_{16} & D_{26} & D_{66} \end{matrix}}{\begin{matrix} A_{11} & A_{16} & B_{12} & B_{22} & B_{26} \\ A_{16} & A_{66} & B_{16} & B_{26} & B_{66} \\ B_{11} & B_{16} & D_{11} & D_{12} & D_{16} \\ B_{12} & B_{26} & D_{12} & D_{22} & D_{26} \\ B_{16} & B_{66} & D_{16} & D_{26} & D_{66} \end{matrix}}$$

VI. ENVIRONMENTAL EFFECTS

A. Importance

Like all engineering materials, laminates will contain residual stresses from processing, or will experience strains due to thermal effects or moisture absorption. However, because of the anisotropic nature of composite laminates, these effects become much more important. It is well known that most laminates are processed or "cured" at elevated temperatures. It is at this elevated temperature that the molecular structure of the material is set. Upon cooling, the laminate will experience many internal stresses as each ply contracts a different amount in different directions. For unsymmetric laminates, this can be seen by warpage of a flat plate as it is removed from its molding platens. In some cases, this warpage is desirable to achieve a natural "twist" in the material (such as for helicopter rotors). In general, the more anisotropic the laminate, the more important the residual thermal and moisture absorption stresses become. The thermal effects will be quite important in the next section on ply stresses.

B. Coefficients of Thermal Expansion

Just like any other material, fiber/resin systems will experience a change in strain with a change in temperature. These strains are defined by the coefficients of thermal expansion. These values are material constants in each principal material direction. Thus, two constants will describe the thermal expansion coefficients for any lamina. These are defined as:

α_1 – coefficient of thermal expansion in the fiber direction

and

α_2 – coefficient of thermal expansion in the direction perpendicular to the fibers.

These values have dimensions of inch/inch/°F or inch/inch/°C, depending on the temperature scale that is being used.

Just as with the mechanical strains, the thermal strains must be transformed into the laminate coordinate system:

$$\begin{bmatrix} \alpha_x \\ \alpha_y \\ \alpha_{xy} \end{bmatrix} = \begin{bmatrix} \cos^2 \theta & \sin^2 \theta & -2 \sin \theta \cos \theta \\ \sin^2 \theta & \cos^2 \theta & 2 \sin \theta \cos \theta \\ \sin \theta \cos \theta & -\sin \theta \cos \theta & (\cos^2 \theta - \sin^2 \theta) \end{bmatrix} \begin{bmatrix} \alpha_1 \\ \alpha_2 \\ 0 \end{bmatrix} . \quad (90)$$

Note that a coefficient of thermal expansion for shear is formulated if the lamina being examined does not have its material axes as principal material axes (i.e., $\theta \neq 0^\circ$ or 90°). The amount of thermal strain induced in each lamina is given by:

$$\begin{aligned} \epsilon_x^T &= \alpha_x \Delta T , \\ \epsilon_y^T &= \alpha_y \Delta T , \\ \epsilon_{xy}^T &= \frac{\gamma_{xy}^T}{2} = \alpha_{xy} \Delta T , \end{aligned} \quad (91)$$

where the superscript T denotes “thermal,” and ΔT denotes the change in temperature from cure to operating temperature.

These thermal strains are now treated just like the mechanical strains considered earlier. Therefore, from equation (43), it can be seen that when these thermal strains are combined for each layer of the laminate, thermal stress resultants are present:

$$\begin{bmatrix} N_x^T \\ N_y^T \\ N_{xy}^T \end{bmatrix} = \sum_{k=1}^n \begin{bmatrix} \bar{Q}_{11} & \bar{Q}_{12} & \bar{Q}_{16} \\ \bar{Q}_{12} & \bar{Q}_{22} & \bar{Q}_{26} \\ \bar{Q}_{16} & \bar{Q}_{26} & \bar{Q}_{66} \end{bmatrix}_k \begin{bmatrix} \epsilon_x^T \\ \epsilon_y^T \\ \gamma_{xy}^T \end{bmatrix}_k (h_k - h_{k-1}) . \quad (92)$$

From equation (44), it can be seen that thermal moment resultants also develop:

$$\begin{bmatrix} M_x^T \\ M_y^T \\ M_{xy}^T \end{bmatrix} = \sum_{k=1}^n \begin{bmatrix} \bar{Q}_{11} & \bar{Q}_{12} & \bar{Q}_{16} \\ \bar{Q}_{12} & \bar{Q}_{22} & \bar{Q}_{26} \\ \bar{Q}_{16} & \bar{Q}_{26} & \bar{Q}_{66} \end{bmatrix}_k \begin{bmatrix} \epsilon_x^T \\ \epsilon_y^T \\ \gamma_{xy}^T \end{bmatrix}_k \frac{1}{2} (h_k^2 - h_{k-1}^2) . \quad (93)$$

These thermal stress and moment resultants can be added to the mechanical stress and moment resultants to arrive at the total stress and moment resultants:

$$\begin{bmatrix} N_x^{Tot} \\ N_y^{Tot} \\ N_{xy}^{Tot} \end{bmatrix} = \begin{bmatrix} N_x^T \\ N_y^T \\ N_{xy}^T \end{bmatrix} + \begin{bmatrix} N_x \\ N_y \\ N_{xy} \end{bmatrix} \quad \text{and} \quad \begin{bmatrix} M_x^{Tot} \\ M_y^{Tot} \\ M_{xy}^{Tot} \end{bmatrix} = \begin{bmatrix} M_x^T \\ M_y^T \\ M_{xy}^T \end{bmatrix} + \begin{bmatrix} M_x \\ M_y \\ M_{xy} \end{bmatrix}, \quad (94)$$

where the superscript Tot denotes “total”.

Typical values of the thermal expansion coefficients for carbon/epoxy is $\alpha_1 = -0.072 \times 10^{-6}$ in/in/°F and $\alpha_2 = 32.4 \times 10^{-6}$ in/in/°F. Note that in the fiber direction, the material actually contracts upon heating (or expands upon cooling). Also, note the large differences in the two coefficients. For this reason, composite materials have been used in many applications where a certain thermal expansion is desired, since plies can be combined to give a wide range of values (including near zero which is very convenient for optical benches).

C. Moisture Effects

Swelling of a composite material due to moisture absorption is handled in the exact same manner as expansion due to temperature differences. The moisture swelling coefficients in each principal material direction must be known. They are designated as β_1 , along the fiber direction, and β_2 , perpendicular to the fiber direction. The strain due to moisture absorption is given by:

$$\begin{aligned} \varepsilon_x^M &= \beta_x \Delta m, \\ \varepsilon_y^M &= \beta_y \Delta m, \\ \gamma_{xy}^M &= \beta_{xy} \Delta m, \end{aligned} \quad (95)$$

where the β_i 's are the transformed moisture expansion coefficients, Δm is the moisture concentration in weight moisture/weight material, and the superscript M denotes “moisture.”

Stress and moment resultants can be determined due to the effects of moisture absorption.

Typical values of moisture expansion coefficients for carbon/epoxy are, $\beta_1 = 0.01$ in/in/g/g and $\beta_2 = 0.35$ in/in/g/g. The moisture concentration is usually a very low number under normal operating circumstances ~ 0.0005 g/g. However, in humid environments this number may be much higher.

VII. STRESSES AND STRAINS WITHIN LAMINAE OF A SYMMETRIC LAMINATE

A. Strains Within the Laminae

So far, in this paper, methods have been shown to describe the stress-strain behavior of a laminate as a whole. In many instances, however, the stresses and/or strains in each ply may need to be known. To do this, the constitutive equation (52) is used to find the total midplane strains and curvatures. From these values, the total strain in each ply can be calculated from equation (30). These strains can then be transformed into strains in the principal material directions by the first equation in (18). As in finding the engineering constants of a laminate, the most involved step in performing this analysis is the manipulation of matrices. The A' , B' , and D' matrices must be found from the A , B , and D matrices.

Example 3:

Using the symmetric laminate in example 1, $[0,+45]_S$, find the strains in each ply in each ply's principal material direction given a tensile load of 1,000 lb on a 2-in wide specimen in the x -direction. The x -direction is parallel to the 0° fibers. Assume no environmental effects.

The specimen is 2-in wide, therefore, the stress resultant is

$$N_x = \frac{1,000 \text{ lb}}{2 \text{ in}} = 500 \frac{\text{lb}}{\text{in}} \quad . \quad (\text{E3.1})$$

From example 1, the A_{ij} are known. Since the laminate is symmetric, the B_{ij} are zero. The D_{ij} are given by:

$$\begin{aligned} D_{11} = & 20,130,785 \text{ lb/in}^2 \left(\frac{(0.005)^3}{12} + (0.005)(0.0075)^2 \right) \text{ in}^3 \\ & + 6,557,237 \text{ lb/in}^2 \left(\frac{(0.005)^3}{12} + (0.005)(0.0025)^2 \right) \text{ in}^3 \\ & + 6,557,237 \text{ lb/in}^2 \left(\frac{(0.005)^3}{12} + (0.005)(-0.0025)^2 \right) \text{ in}^3 \\ & + 20,130,785 \text{ lb/in}^2 \left(\frac{(0.005)^3}{12} + (0.005)(-0.0075)^2 \right) \text{ in}^3 = 12.3 \text{ in-lb} \quad , \end{aligned}$$

$$\begin{aligned}
 D_{12} &= 392,656 \text{ lb/in}^2 \left(\frac{(0.005)^3}{12} + (0.005)(0.0075)^2 \right) \text{in}^3 \\
 &+ 4,555,238 \text{ lb/in}^2 \left(\frac{(0.005)^3}{12} + (0.005)(0.0025)^2 \right) \text{in}^3 \\
 &+ 4,555,238 \text{ lb/in}^2 \left(\frac{(0.005)^3}{12} + (0.005)(-0.0025)^2 \right) \text{in}^3 \\
 &+ 392,656 \text{ lb/in}^2 \left(\frac{(0.005)^3}{12} + (0.005)(-0.0075)^2 \right) \text{in}^3 = 0.609 \text{ in-lb} ,
 \end{aligned}$$

$$\begin{aligned}
 D_{22} &= 1,308,853 \text{ lb/in}^2 \left(\frac{(0.005)^3}{12} + (0.005)(0.0075)^2 \right) \text{in}^3 \\
 &+ 6,557,237 \text{ lb/in}^2 \left(\frac{(0.005)^3}{12} + (0.005)(0.0025)^2 \right) \text{in}^3 \\
 &+ 6,557,237 \text{ lb/in}^2 \left(\frac{(0.005)^3}{12} + (0.005)(-0.0025)^2 \right) \text{in}^3 \\
 &+ 1,308,853 \text{ lb/in}^2 \left(\frac{(0.005)^3}{12} + (0.005)(-0.0075)^2 \right) \text{in}^3 = 1.31 \text{ in-lb} ,
 \end{aligned}$$

$$\begin{aligned}
 D_{16} &= 0 \text{ lb/in}^2 \left(\frac{(0.005)^3}{12} + (0.005)(0.0075)^2 \right) \text{in}^3 \\
 &+ 4,705,483 \text{ lb/in}^2 \left(\frac{(0.005)^3}{12} + (0.005)(0.0025)^2 \right) \text{in}^3 \\
 &+ 4,705,483 \text{ lb/in}^2 \left(\frac{(0.005)^3}{12} + (0.005)(-0.0025)^2 \right) \text{in}^3
 \end{aligned}$$

$$+ 0 \text{ lb/in}^2 \left(\frac{(0.005)^3}{12} + (0.005)(-0.0075)^2 \right) \text{ in}^3 = 0.392 \text{ in-lb} ,$$

$$\begin{aligned} D_{26} &= 0 \text{ lb/in}^2 \left(\frac{(0.005)^3}{12} + (0.005)(0.0075)^2 \right) \text{ in}^3 \\ &+ 4,705,483 \text{ lb/in}^2 \left(\frac{(0.005)^3}{12} + (0.005)(0.0025)^2 \right) \text{ in}^3 \\ &+ 4,705,483 \text{ lb/in}^2 \left(\frac{(0.005)^3}{12} + (0.005)(-0.0025)^2 \right) \text{ in}^3 \\ &+ 0 \text{ lb/in}^2 \left(\frac{(0.005)^3}{12} + (0.005)(-0.0075)^2 \right) \text{ in}^3 = 0.392 \text{ in-lb} , \end{aligned}$$

$$\begin{aligned} D_{66} &= 1,001,000 \text{ lb/in}^2 \left(\frac{(0.005)^3}{12} + (0.005)(0.0075)^2 \right) \text{ in}^3 \\ &+ 5,163,582 \text{ lb/in}^2 \left(\frac{(0.005)^3}{12} + (0.005)(0.0025)^2 \right) \text{ in}^3 \\ &+ 5,163,582 \text{ lb/in}^2 \left(\frac{(0.005)^3}{12} + (0.005)(-0.0025)^2 \right) \text{ in}^3 \\ &+ 1,001,000 \text{ lb/in}^2 \left(\frac{(0.005)^3}{12} + (0.005)(-0.0075)^2 \right) \text{ in}^3 = 1.014 \text{ in-lb} . \end{aligned}$$

Using equations (51) and (53), the A' and D' matrices can be found. The B' and C' matrices will be zero since the B matrix is zero.

$$[A'] = [A]^{-1} = \left[\begin{pmatrix} 266,880 & 49,479 & 47,055 \\ 49,479 & 78,661 & 47,055 \\ 47,055 & 47,055 & 61,646 \end{pmatrix} \frac{\text{lb}}{\text{in}} \right]^{-1} = \begin{bmatrix} 4.41 & -1.4 & -2.3 \\ -1.4 & 23.8 & -17.1 \\ -2.3 & -17.1 & 31.05 \end{bmatrix} \times 10^{-6} \frac{\text{in}}{\text{lb}} , \quad (\text{E3.2})$$

$$[D'] = [D]^{-1} = \left[\begin{pmatrix} 12.3 & 0.609 & 0.392 \\ 0.609 & 1.31 & 0.392 \\ 0.392 & 0.392 & 1.014 \end{pmatrix} \text{in-lb} \right]^{-1} = \begin{bmatrix} 0.0836 & -0.033 & -0.0195 \\ -0.033 & 0.876 & -0.326 \\ -0.0195 & -0.326 & 1.12 \end{bmatrix} (\text{in-lb})^{-1} \quad . \quad (\text{E3.3})$$

Therefore, the constitutive equation is:

$$\begin{bmatrix} \varepsilon_x^0 \\ \varepsilon_y^0 \\ \gamma_{xy}^0 \\ K_x \\ K_y \\ K_{xy} \end{bmatrix} = \begin{bmatrix} A'_{11} & A'_{12} & A'_{16} & 0 & 0 & 0 \\ A'_{12} & A'_{22} & A'_{26} & 0 & 0 & 0 \\ A'_{16} & A'_{26} & A'_{66} & 0 & 0 & 0 \\ 0 & 0 & 0 & D'_{11} & D'_{12} & D'_{16} \\ 0 & 0 & 0 & D'_{12} & D'_{22} & D'_{26} \\ 0 & 0 & 0 & D'_{16} & D'_{26} & D'_{66} \end{bmatrix} \begin{bmatrix} N_x \\ 0 \\ 0 \\ 0 \\ 0 \\ 0 \end{bmatrix}$$

$$\Rightarrow \begin{aligned} \varepsilon_x^0 &= A'_{11} N_x = 4.41 \times 10^{-6} \frac{\text{in}}{\text{lb}} \left(500 \frac{\text{lb}}{\text{in}} \right) = 0.00221 \frac{\text{in}}{\text{in}} \\ \varepsilon_y^0 &= A'_{12} N_x = -1.4 \times 10^{-6} \frac{\text{in}}{\text{lb}} \left(500 \frac{\text{lb}}{\text{in}} \right) = -0.0007 \frac{\text{in}}{\text{in}} \\ \gamma_{xy}^0 &= A'_{16} N_x = -2.3 \times 10^{-6} \frac{\text{in}}{\text{lb}} \left(500 \frac{\text{lb}}{\text{in}} \right) = -0.00115 \frac{\text{in}}{\text{in}} \\ K_x &= 0; \quad K_y = 0; \quad K_{xy} = 0 \end{aligned} \quad (\text{E3.4})$$

These are the midplane strains and curvatures. Using equation (30), it can be seen that since the midplane curvatures are zero, then the strains in each ply will be equal to the midplane strains. In other words, the strains are constant through the thickness in any given direction since there is no bending and therefore z does not enter into the calculation.

To transform these strains into the principal material directions for the $+45^\circ$ ply:

$$\begin{bmatrix} \varepsilon_1 \\ \varepsilon_2 \\ \frac{\gamma_{12}}{2} \end{bmatrix}_{+45} = \begin{bmatrix} \cos^2 45^\circ & \sin^2 45^\circ & 2\sin 45^\circ \cos 45^\circ \\ \sin^2 45^\circ & \cos^2 45^\circ & -2\sin 45^\circ \cos 45^\circ \\ -\sin 45^\circ \cos 45^\circ & \sin 45^\circ \cos 45^\circ & (\cos^2 45^\circ - \sin^2 45^\circ) \end{bmatrix} \begin{bmatrix} 0.00221 \\ -0.0007 \\ \frac{-0.00115}{2} \end{bmatrix} \quad (E3.5)$$

$$\varepsilon_1^{+45} = 0.00018; \quad \varepsilon_2^{+45} = 0.00133; \quad \gamma_{12}^{+45} = -0.00291$$

Note: Recall that the engineering shear strain must be put into tensorial shear strain, $\varepsilon_{xy} = 1/2 \gamma_{xy}$, before transformation.

B. Stresses Within the Laminae

The stresses in a lamina can be determined once the strains are known by applying equation (23) to each ply. If thermal or moisture strains are present, these strains must be subtracted from the total strain since they are not caused by an external force.

Example 3a:

Find the stresses in each ply of the laminate in example 3.

$$\begin{bmatrix} \sigma_x \\ \sigma_y \\ \tau_{xy} \end{bmatrix}_0 = \begin{bmatrix} 20,130,785 & 392,656 & 0 \\ 392,656 & 1,308,853 & 0 \\ 0 & 0 & 1,001,000 \end{bmatrix} \text{lb/in}^2 \begin{bmatrix} 0.00221 \\ -0.0007 \\ -0.00115 \end{bmatrix}_0 = \begin{bmatrix} \sigma_x \\ \sigma_y \\ \tau_{xy} \end{bmatrix}_0 = \begin{bmatrix} 44,214 \\ 48 \\ -1,151 \end{bmatrix} \text{lb/in}^2 \quad (E3a.1)$$

$$\begin{bmatrix} \sigma_x \\ \sigma_y \\ \tau_{xy} \end{bmatrix}_{+45} = \begin{bmatrix} 6,557,237 & 4,555,238 & 4,705,483 \\ 4,555,238 & 6,557,237 & 4,705,483 \\ 4,705,483 & 4,705,483 & 5,163,582 \end{bmatrix} \text{lb/in}^2 \begin{bmatrix} 0.00221 \\ -0.0007 \\ -0.00115 \end{bmatrix}_{+45} = \begin{bmatrix} \sigma_x \\ \sigma_y \\ \tau_{xy} \end{bmatrix}_{+45} = \begin{bmatrix} 5,892 \\ 66 \\ 1,167 \end{bmatrix} \text{lb/in}^2 \quad (E3a.2)$$

Transforming the +45° ply into its principal material directions:

$$\begin{bmatrix} \sigma_1 \\ \sigma_2 \\ \tau_{12} \end{bmatrix}_{+45} = \begin{bmatrix} \cos^2 45^\circ & \sin^2 45^\circ & 2\sin 45^\circ \cos 45^\circ \\ \sin^2 45^\circ & \cos^2 45^\circ & -2\sin 45^\circ \cos 45^\circ \\ -\sin 45^\circ \cos 45^\circ & \sin 45^\circ \cos 45^\circ & (\cos^2 45^\circ - \sin^2 45^\circ) \end{bmatrix} \begin{bmatrix} 5892 \\ 66 \\ 1167 \end{bmatrix} \text{lb/in}^2$$

$$\sigma_1^{+45} = 4,146 \text{ lb/in}^2; \quad \sigma_2^{+45} = 1,812 \text{ lb/in}^2; \quad \tau_{12}^{+45} = -2,913 \text{ lb/in}^2 \quad (E3a.3)$$

Example 4:

The importance of thermal effects can be found by working problem 3, taking into account that the laminate was cured at 176.7 °C and tested at 21.1 °C. This implies a ΔT of -155.6 °C. The coefficients of thermal expansion for AS4/3501-6 are given below:

$$\alpha_1 = -0.04 \times 10^{-6} \frac{\text{in}}{\text{in } ^\circ\text{C}} ; \quad \alpha_2 = 18 \times 10^{-6} \frac{\text{in}}{\text{in } ^\circ\text{C}} . \quad (\text{E4.1})$$

Using equation (90), for the 0° plies the coefficients are:

$$\alpha_x = -0.04 \times 10^{-6} \frac{\text{in}}{\text{in } ^\circ\text{C}} ; \quad \alpha_y = 18 \times 10^{-6} \frac{\text{in}}{\text{in } ^\circ\text{C}} , \quad (\text{E4.2})$$

and for the +45° plies:

$$\alpha_x^{+45} = 8.98 \times 10^{-6} \frac{\text{in}}{\text{in } ^\circ\text{C}} ; \quad \alpha_y^{+45} = 8.98 \times 10^{-6} \frac{\text{in}}{\text{in } ^\circ\text{C}} ; \quad \alpha_{xy}^{+45} = -9.02 \times 10^{-6} \frac{\text{in}}{\text{in } ^\circ\text{C}} . \quad (\text{E4.3})$$

From equation (91), the thermal strains in the 0° and the 45° plies can be found:

$$\epsilon_x^{0T} = 0.0000062 \frac{\text{in}}{\text{in}} ; \quad \epsilon_y^{0T} = -0.0028 ; \quad \gamma_{xy}^{0T} = 0 \quad (\text{E4.4})$$

$$\epsilon_x^{+45T} = -0.0014 \frac{\text{in}}{\text{in}} ; \quad \epsilon_y^{+45T} = -0.0014 ; \quad \gamma_{xy}^{+45T} = 0.0028 \quad (\text{E4.5})$$

Using equations (92) and (93), these can be converted into thermal stress and moment resultants:

$$\begin{bmatrix} N_x^T \\ N_y^T \\ N_{xy}^T \end{bmatrix} = \begin{bmatrix} -33.57 \\ -60.42 \\ 12.83 \end{bmatrix} \frac{\text{in}}{\text{lb}} \quad (\text{E4.6})$$

The thermal moment resultants will be zero for the same reason the B_{ij} are zero, the laminate is symmetric. Thus:

$$\begin{bmatrix} \varepsilon_x^0 \\ \varepsilon_y^0 \\ \gamma_{xy}^0 \\ K_x \\ K_y \\ K_{xy} \end{bmatrix} = \begin{bmatrix} A'_{11} & A'_{12} & A'_{16} & 0 & 0 & 0 \\ A'_{12} & A'_{22} & A'_{26} & 0 & 0 & 0 \\ A'_{16} & A'_{26} & A'_{66} & 0 & 0 & 0 \\ 0 & 0 & 0 & D'_{11} & D'_{12} & D'_{16} \\ 0 & 0 & 0 & D'_{12} & D'_{22} & D'_{26} \\ 0 & 0 & 0 & D'_{16} & D'_{26} & D'_{66} \end{bmatrix} \begin{bmatrix} N_x^{Tot} \\ N_y^{Tot} \\ N_{xy}^{Tot} \\ 0 \\ 0 \\ 0 \end{bmatrix}$$

$$\varepsilon_x^0 = 4.41 \times 10^{-6} \frac{\text{in}^2}{\text{lb}} \left(466.43 \frac{\text{lb}}{\text{in}} \right) - 1.4 \times 10^{-6} \frac{\text{in}^2}{\text{lb}} \left(-60.42 \frac{\text{lb}}{\text{in}} \right) - 2.3 \times 10^{-6} \frac{\text{in}^2}{\text{lb}} \left(12.83 \frac{\text{lb}}{\text{in}} \right) = 0.00211$$

$$\varepsilon_y^0 = -1.4 \times 10^{-6} \frac{\text{in}^2}{\text{lb}} \left(466.43 \frac{\text{lb}}{\text{in}} \right) + 23.8 \times 10^{-6} \frac{\text{in}^2}{\text{lb}} \left(-60.42 \frac{\text{lb}}{\text{in}} \right) - 17.1 \times 10^{-6} \frac{\text{in}^2}{\text{lb}} \left(12.83 \frac{\text{lb}}{\text{in}} \right) = -0.00231$$

$$\gamma_{xy}^0 = -2.3 \times 10^{-6} \frac{\text{in}^2}{\text{lb}} \left(466.43 \frac{\text{lb}}{\text{in}} \right) - 17.1 \times 10^{-6} \frac{\text{in}^2}{\text{lb}} \left(-60.42 \frac{\text{lb}}{\text{in}} \right) + 31.05 \times 10^{-6} \frac{\text{in}^2}{\text{lb}} \left(12.83 \frac{\text{lb}}{\text{in}} \right) = 0.00036$$

$$K_x = 0 \quad ; \quad K_y = 0 \quad ; \quad K_{xy} = 0$$

(E4.7)

Transforming these into principal material directions for the 45° plies gives:

$$\begin{bmatrix} \varepsilon_1 \\ \varepsilon_2 \\ \frac{\gamma_{12}}{2} \end{bmatrix}_{+45} = \begin{bmatrix} \cos^2 45^\circ & \sin^2 45^\circ & 2\sin 45^\circ \cos 45^\circ \\ \sin^2 45^\circ & \cos^2 45^\circ & -2\sin 45^\circ \cos 45^\circ \\ -\sin 45^\circ \cos 45^\circ & \sin 45^\circ \cos 45^\circ & (\cos^2 45^\circ - \sin^2 45^\circ) \end{bmatrix} \begin{bmatrix} 0.00211 \\ -0.00231 \\ \frac{0.00036}{2} \end{bmatrix}$$

(E4.8)

$$\varepsilon_1^{+45} = 0.0001 \quad ; \quad \varepsilon_2^{+45} = -0.0003 \quad ; \quad \gamma_{12}^{+45} = -0.00442$$

The lamina stresses are:

$$\begin{bmatrix} \sigma_x \\ \sigma_y \\ \tau_{xy} \end{bmatrix}_0 = \begin{bmatrix} 20,130,785 & 392,656 & 0 \\ 392,656 & 1,308,853 & 0 \\ 0 & 0 & 1,001,000 \end{bmatrix} \text{lb/in}^2 \begin{bmatrix} 0.00211-0.000006 \\ -0.00231-(-0.0028) \\ 0.00036-0 \end{bmatrix}_0$$

$$\begin{bmatrix} \sigma_x \\ \sigma_y \\ \tau_{xy} \end{bmatrix}_0 = \begin{bmatrix} 42,543 \\ 1,467 \\ 360 \end{bmatrix} \text{lb/in}^2 \quad (\text{E4.9})$$

For the 0° ply, the x-direction, stress is altered slightly, but the y-direction and shear stresses are quite different due to the thermal effects.

$$\begin{bmatrix} \sigma_x \\ \sigma_y \\ \tau_{xy} \end{bmatrix}_{+45} = \begin{bmatrix} 6,557,237 & 4,555,238 & 4,705,483 \\ 4,555,238 & 6,557,237 & 4,705,483 \\ 4,705,483 & 4,705,483 & 5,163,582 \end{bmatrix} \text{lb/in}^2 \begin{bmatrix} 0.00211-(-0.0014) \\ -0.00231-(-0.0014) \\ 0.00036-0.0028 \end{bmatrix}_{+45}$$

$$\begin{bmatrix} \sigma_x \\ \sigma_y \\ \tau_{xy} \end{bmatrix}_{+45} = \begin{bmatrix} 7,389 \\ -1,460 \\ -366 \end{bmatrix} \text{lb/in}^2 \quad (\text{E4.10})$$

Transforming the +45° ply stresses into principal material direction stresses:

$$\begin{bmatrix} \sigma_1 \\ \sigma_2 \\ \tau_{12} \end{bmatrix}_{+45} = \begin{bmatrix} \cos^2 45^\circ & \sin^2 45^\circ & 2 \sin 45^\circ \cos 45^\circ \\ \sin^2 45^\circ & \cos^2 45^\circ & -2 \sin 45^\circ \cos 45^\circ \\ -\sin 45^\circ \cos 45^\circ & \sin 45^\circ \cos 45^\circ & (\cos^2 45^\circ - \sin^2 45^\circ) \end{bmatrix} \begin{bmatrix} 7,389 \\ -1,460 \\ -365 \end{bmatrix} \text{lb/in}^2$$

$$\sigma_1^{+45} = 2,600 \text{ lb/in}^2 ; \quad \sigma_2^{+45} = 3,330 \text{ lb/in}^2 ; \quad \tau_{12}^{+45} = -4,425 \text{ lb/in}^2 \quad (\text{E4.11})$$

For the + 45° plies, the stresses vary substantially in all directions due to thermal effects.

Example 5:

Perform the same exercise as above taking into account moisture uptake. The amount of moisture absorbed by the composite is 0.007 g/g, and the moisture swelling coefficients are $\beta_1 = 0.01$ in/in/g/g and $\beta_2 = 0.35$ in/in/g/g.

The moisture expansion coefficients need to be transformed for the +45° plies;

$$\begin{bmatrix} \beta_x \\ \beta_y \\ \beta_{xy} \end{bmatrix}_{+45} = \begin{bmatrix} \cos^2 45^\circ & \sin^2 45^\circ & -2 \sin 45^\circ \cos 45^\circ \\ \sin^2 45^\circ & \cos^2 45^\circ & 2 \sin 45^\circ \cos 45^\circ \\ \sin 45^\circ \cos 45^\circ & -\sin 45^\circ \cos 45^\circ & \cos^2 45^\circ - \sin^2 45^\circ \end{bmatrix} \begin{bmatrix} 0.01 \\ 0.35 \\ 0 \end{bmatrix} \quad (E5.1)$$

$$\beta_x^{+45} = 0.18 \text{ in/in/g/g} ; \beta_y^{+45} = 0.18 \text{ in/in/g/g} ; \beta_{xy}^{+45} = -0.17 \text{ in/in/g/g}$$

The strains due to moisture uptake are given by equation (95):

$$\begin{aligned} \epsilon_x^{0M} &= 0.00007 \frac{\text{in}}{\text{in}} ; \epsilon_y^{0M} = 0.00245 \frac{\text{in}}{\text{in}} ; \gamma_{xy}^{0M} = 0 \\ \epsilon_x^{+45M} &= 0.00126 \frac{\text{in}}{\text{in}} ; \epsilon_y^{+45M} = 0.00126 \frac{\text{in}}{\text{in}} ; \gamma_{xy}^{+45M} = -0.00238 \frac{\text{in}}{\text{in}} \end{aligned} \quad (E5.2)$$

The stress and moment resultants due to moisture swelling can now be calculated using equations (92) and (93):

$$\begin{bmatrix} N_x^M \\ N_y^M \\ N_{xy}^M \end{bmatrix} = \begin{bmatrix} 51.7 \\ 60.4 \\ -4.3 \end{bmatrix} \frac{\text{in}}{\text{lb}} \quad (E5.2)$$

The moisture moment resultants will be zero since the laminate is symmetric.

The new total stress resultant is the sum of the mechanical, thermal, and moisture stress resultants:

$$\begin{bmatrix} N_x^{Tot} \\ N_y^{Tot} \\ N_{xy}^{Tot} \end{bmatrix} = \begin{bmatrix} 500 \\ 0 \\ 0 \end{bmatrix} \frac{\text{in}}{\text{lb}} + \begin{bmatrix} -33.6 \\ -60.4 \\ 12.8 \end{bmatrix} \frac{\text{in}}{\text{lb}} + \begin{bmatrix} 51.7 \\ 60.4 \\ -4.3 \end{bmatrix} \frac{\text{in}}{\text{lb}} = \begin{bmatrix} 518.1 \\ 0 \\ 8.5 \end{bmatrix} \frac{\text{in}}{\text{lb}} \quad (E5.4)$$

Using the constitutive equation, the midplane strains can be calculated as they were in equations (E3.4) and (E4.7).

$$\begin{bmatrix} \varepsilon_x^0 \\ \varepsilon_y^0 \\ \gamma_{xy}^0 \\ K_x \\ K_y \\ K_{xy} \end{bmatrix} = \begin{bmatrix} A'_{11} & A'_{12} & A'_{16} & 0 & 0 & 0 \\ A'_{12} & A'_{22} & A'_{26} & 0 & 0 & 0 \\ A'_{16} & A'_{26} & A'_{66} & 0 & 0 & 0 \\ 0 & 0 & 0 & D'_{11} & D'_{12} & D'_{16} \\ 0 & 0 & 0 & D'_{12} & D'_{22} & D'_{26} \\ 0 & 0 & 0 & D'_{16} & D'_{26} & D'_{66} \end{bmatrix} \begin{bmatrix} N_x^{Tot} \\ N_y^{Tot} \\ N_{xy}^{Tot} \\ 0 \\ 0 \\ 0 \end{bmatrix}$$

$$\begin{aligned} \varepsilon_x^0 &= 4.41 \times 10^{-6} \frac{\text{in}^2}{\text{lb}} \left(518.1 \frac{\text{lb}}{\text{in}} \right) - 1.4 \times 10^{-6} \frac{\text{in}^2}{\text{lb}} \left(0 \frac{\text{lb}}{\text{in}} \right) - 2.3 \times 10^{-6} \frac{\text{in}^2}{\text{lb}} \left(8.5 \frac{\text{lb}}{\text{in}} \right) = 0.00227 \\ \varepsilon_y^0 &= -1.4 \times 10^{-6} \frac{\text{in}^2}{\text{lb}} \left(518.1 \frac{\text{lb}}{\text{in}} \right) + 23.8 \times 10^{-6} \frac{\text{in}^2}{\text{lb}} \left(0 \frac{\text{lb}}{\text{in}} \right) - 17.1 \times 10^{-6} \frac{\text{in}^2}{\text{lb}} \left(8.5 \frac{\text{lb}}{\text{in}} \right) = -0.00087 \\ \gamma_{xy}^0 &= -2.3 \times 10^{-6} \frac{\text{in}^2}{\text{lb}} \left(518.1 \frac{\text{lb}}{\text{in}} \right) - 17.1 \times 10^{-6} \frac{\text{in}^2}{\text{lb}} \left(0 \frac{\text{lb}}{\text{in}} \right) + 31.05 \times 10^{-6} \frac{\text{in}^2}{\text{lb}} \left(8.5 \frac{\text{lb}}{\text{in}} \right) = -0.00093 \end{aligned} \quad (E5.5)$$

$$K_x = 0 ; \quad K_y = 0 ; \quad K_{xy} = 0$$

Transforming these strains into principal material direction strains for the +45° plies;

$$\begin{bmatrix} \varepsilon_1 \\ \varepsilon_2 \\ \frac{\gamma_{12}}{2} \end{bmatrix}_{+45} = \begin{bmatrix} \cos^2 45^\circ & \sin^2 45^\circ & 2 \sin 45^\circ \cos 45^\circ \\ \sin^2 45^\circ & \cos^2 45^\circ & -2 \sin 45^\circ \cos 45^\circ \\ -\sin 45^\circ \cos 45^\circ & \sin 45^\circ \cos 45^\circ & (\cos^2 45^\circ - \sin^2 45^\circ) \end{bmatrix} \begin{bmatrix} 0.00227 \\ -0.00087 \\ \frac{-0.00093}{2} \end{bmatrix} \quad (E5.6)$$

$$\varepsilon_1^{+45} = 0.00024 ; \quad \varepsilon_2^{+45} = 0.00117 ; \quad \gamma_{12}^{+45} = -0.00314$$

The stresses in the 0° plies are given by:

$$\begin{bmatrix} \sigma_x \\ \sigma_y \\ \tau_{xy} \end{bmatrix}_0 = \begin{bmatrix} 20,130,785 & 392,656 & 0 \\ 392,656 & 1,308,853 & 0 \\ 0 & 0 & 1,001,000 \end{bmatrix} \text{lb/in}^2 \begin{bmatrix} 0.00227-0.000006-0.00007 \\ -0.00087-(-0.0028)-0.00245 \\ -0.00093-0-0 \end{bmatrix}_0$$

$$\begin{bmatrix} \sigma_x \\ \sigma_y \\ \tau_{xy} \end{bmatrix}_0 = \begin{bmatrix} 43,963 \\ 181 \\ -931 \end{bmatrix} \text{lb/in}^2 \quad (E5.7)$$

The stresses in the +45° plies are given by:

$$\begin{bmatrix} \sigma_x \\ \sigma_y \\ \tau_{xy} \end{bmatrix}_{+45} = \begin{bmatrix} 6,557,237 & 4,555,238 & 4,705,483 \\ 4,555,238 & 6,557,237 & 4,705,483 \\ 4,705,483 & 4,705,483 & 5,163,582 \end{bmatrix} \text{lb/in}^2 \begin{bmatrix} 0.00227-(-0.0014)-0.00126 \\ -0.00087-(-0.0014)-0.00126 \\ -0.00093-0.0028-(-0.00238) \end{bmatrix}_{+45}$$

$$\begin{bmatrix} \sigma_x \\ \sigma_y \\ \tau_{xy} \end{bmatrix}_{+45} = \begin{bmatrix} 6,125 \\ -161 \\ 934 \end{bmatrix} \text{lb/in}^2 \quad (E5.8)$$

Transforming these stresses into principal material directions for the +45° plies:

$$\begin{bmatrix} \sigma_1 \\ \sigma_2 \\ \tau_{12} \end{bmatrix}_{+45} = \begin{bmatrix} \cos^2 45^\circ & \sin^2 45^\circ & 2 \sin 45^\circ \cos 45^\circ \\ \sin^2 45^\circ & \cos^2 45^\circ & -2 \sin 45^\circ \cos 45^\circ \\ -\sin 45^\circ \cos 45^\circ & \sin 45^\circ \cos 45^\circ & (\cos^2 45^\circ - \sin^2 45^\circ) \end{bmatrix} \begin{bmatrix} 6,125 \\ -161 \\ 934 \end{bmatrix} \text{lb/in}^2$$

$$\sigma_1^{+45} = 3,916 \text{ lb/in}^2 ; \quad \sigma_2^{+45} = 2,048 \text{ lb/in}^2 ; \quad \tau_{12}^{+45} = -3,143 \text{ lb/in}^2 \quad (E5.9)$$

The swelling strain of moisture uptake tends to diminish the contraction due to processing thermal differences.

Example 6:

Find the stresses and strains in each lamina of the laminate used in the previous examples if the laminate is subjected to a bending moment in the 0° fiber direction of 5 in-lb/in.

The constitutive equation is:

$$\begin{bmatrix} \varepsilon_x^0 \\ \varepsilon_y^0 \\ \gamma_{xy}^0 \\ K_x \\ K_y \\ K_{xy} \end{bmatrix} = \begin{bmatrix} A'_{11} & A'_{12} & A'_{16} & 0 & 0 & 0 \\ A'_{12} & A'_{22} & A'_{26} & 0 & 0 & 0 \\ A'_{16} & A'_{26} & A'_{66} & 0 & 0 & 0 \\ 0 & 0 & 0 & D'_{11} & D'_{12} & D'_{16} \\ 0 & 0 & 0 & D'_{12} & D'_{22} & D'_{26} \\ 0 & 0 & 0 & D'_{16} & D'_{26} & D'_{66} \end{bmatrix} \begin{bmatrix} 0 \\ 0 \\ 0 \\ M_x \\ 0 \\ 0 \end{bmatrix}$$

$$\Rightarrow \begin{aligned} K_x &= D'_{11} M_x = 0.0836 \frac{\text{in-lb}}{\text{in}} \left(5 \frac{\text{in-lb}}{\text{in}} \right) = 0.418 \frac{\text{in}}{\text{in}} \\ K_y &= D'_{12} M_x = -0.033 \frac{\text{in-lb}}{\text{in}} \left(5 \frac{\text{in-lb}}{\text{in}} \right) = -0.165 \frac{\text{in}}{\text{in}} \\ K_{xy} &= D'_{16} M_x = -0.0195 \frac{\text{in-lb}}{\text{in}} \left(5 \frac{\text{in-lb}}{\text{in}} \right) = -0.0975 \frac{\text{in}}{\text{in}} \end{aligned} \tag{E6.1}$$

$$\varepsilon_x^0 = 0 ; \quad \varepsilon_y^0 = 0 ; \quad \gamma_{xy}^0 = 0$$

Using equation (30), it can be seen that the strains in each ply will vary across the thickness of the ply. Thus, the distance the ply is away from the geometric midplane must be taken into account, as well as the direction of the fibers as in the previous examples. For clarity, assign the four plies of the laminate numbers as shown in the following:

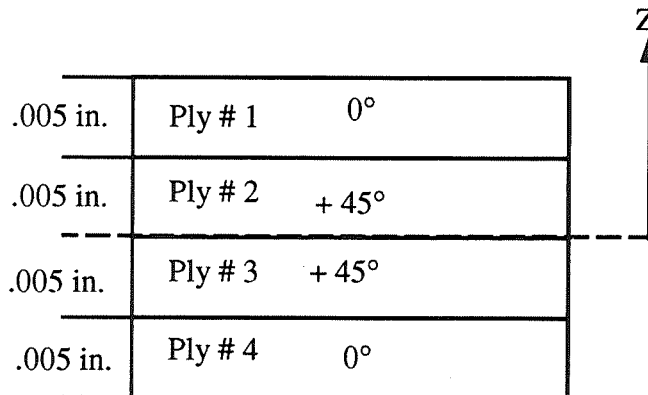

Since this laminate is symmetric, the geometric midplane is also the neutral plane of the plate. Thus, the strains will be zero at the bottom of ply No. 2 and at the top of ply No. 3. The following are calculations for other planes within the plate.

The top of ply No. 2:

$$\begin{bmatrix} \varepsilon_x \\ \varepsilon_y \\ \gamma_{xy} \end{bmatrix}_{+45}^{\text{Top}} = 0.005 \text{ in} \begin{bmatrix} 0.418 \\ -0.165 \\ -0.0975 \end{bmatrix} \frac{1}{\text{in}} = \begin{bmatrix} 0.00209 \\ -0.00083 \\ -0.00049 \end{bmatrix} . \quad (\text{E6.2})$$

The bottom of ply No. 1 is at the same geometric location as the top of ply No. 2 (i.e., at $z = 0.005$ in). Thus, the strains will be the same.

The top of ply No. 1:

$$\begin{bmatrix} \varepsilon_x \\ \varepsilon_y \\ \gamma_{xy} \end{bmatrix}_0^{\text{Top}} = 0.01 \text{ in} \begin{bmatrix} 0.418 \\ -0.165 \\ -0.0975 \end{bmatrix} \frac{1}{\text{in}} = \begin{bmatrix} 0.00418 \\ -0.00165 \\ -0.000975 \end{bmatrix} \quad (\text{E6.3})$$

The bottom of ply No. 3:

$$\begin{bmatrix} \varepsilon_x \\ \varepsilon_y \\ \gamma_{xy} \end{bmatrix}_{+45}^{\text{Bot.}} = -0.005 \text{ in} \begin{bmatrix} 0.418 \\ -0.165 \\ -0.0975 \end{bmatrix} \frac{1}{\text{in}} = \begin{bmatrix} -0.00209 \\ 0.00083 \\ 0.00049 \end{bmatrix} . \quad (\text{E6.4})$$

The top of ply No. 4 is at the same location as the bottom of ply No. 3 and, thus, will have the above strains.

The bottom of ply No 4:

$$\begin{bmatrix} \varepsilon_x \\ \varepsilon_y \\ \gamma_{xy} \end{bmatrix}_0^{\text{Bot.}} = -0.01 \text{ in} \begin{bmatrix} 0.418 \\ -0.165 \\ -0.0975 \end{bmatrix} \frac{1}{\text{in}} = \begin{bmatrix} -0.00418 \\ 0.00165 \\ 0.000975 \end{bmatrix} . \quad (\text{E6.5})$$

Transforming these strains into strains in the principal material directions for the +45 ° plies:

Top of ply No. 2:

$$\begin{bmatrix} \varepsilon_1 \\ \varepsilon_2 \\ \frac{\gamma_{12}}{2} \end{bmatrix}_{+45} = \begin{bmatrix} \cos^2 45^\circ & \sin^2 45^\circ & 2 \sin 45^\circ \cos 45^\circ \\ \sin^2 45^\circ & \cos^2 45^\circ & -2 \sin 45^\circ \cos 45^\circ \\ -\sin 45^\circ \cos 45^\circ & \sin 45^\circ \cos 45^\circ & (\cos^2 45^\circ - \sin^2 45^\circ) \end{bmatrix} \begin{bmatrix} 0.00209 \\ -0.00083 \\ \frac{-0.00049}{2} \end{bmatrix} \quad (E6.6)$$

$$\varepsilon_1^{+45} = 0.00039 \quad ; \quad \varepsilon_2^{+45} = 0.00088 \quad ; \quad \gamma_{12}^{+45} = -0.00292$$

Bottom of ply No. 3:

$$\begin{bmatrix} \varepsilon_1 \\ \varepsilon_2 \\ \frac{\gamma_{12}}{2} \end{bmatrix}_{+45} = \begin{bmatrix} \cos^2 45^\circ & \sin^2 45^\circ & 2 \sin 45^\circ \cos 45^\circ \\ \sin^2 45^\circ & \cos^2 45^\circ & -2 \sin 45^\circ \cos 45^\circ \\ -\sin 45^\circ \cos 45^\circ & \sin 45^\circ \cos 45^\circ & (\cos^2 45^\circ - \sin^2 45^\circ) \end{bmatrix} \begin{bmatrix} -0.00209 \\ 0.00083 \\ \frac{0.00049}{2} \end{bmatrix} \quad (E6.7)$$

$$\varepsilon_1^{+45} = -0.00039 \quad ; \quad \varepsilon_2^{+45} = -0.00088 \quad ; \quad \gamma_{12}^{+45} = 0.00292$$

The stresses within the laminate is calculated from the strain using equation (23):

Top of ply No. 1:

$$\begin{bmatrix} \sigma_x \\ \sigma_y \\ \tau_{xy} \end{bmatrix}_0^{\text{Top}} = \begin{bmatrix} 20,130,785 & 392,656 & 0 \\ 392,656 & 1,308,853 & 0 \\ 0 & 0 & 1,001,000 \end{bmatrix} \text{lb/in}^2 \begin{bmatrix} 0.00418 \\ -0.00165 \\ -0.000975 \end{bmatrix}_0$$

$$\begin{bmatrix} \sigma_x \\ \sigma_y \\ \tau_{xy} \end{bmatrix}_0^{\text{Top}} = \begin{bmatrix} 83,500 \\ -518 \\ -976 \end{bmatrix} \text{lb/in}^2 \quad (E6.8)$$

Bottom of ply No. 1:

$$\begin{bmatrix} \sigma_x \\ \sigma_y \\ \tau_{xy} \end{bmatrix}_{0}^{\text{Bot.}} = \begin{bmatrix} 20,130,785 & 392,656 & 0 \\ 392,656 & 1,308,853 & 0 \\ 0 & 0 & 1,001,000 \end{bmatrix} \text{lb/in}^2 \begin{bmatrix} 0.00209 \\ -0.00083 \\ -0.00049 \end{bmatrix}_0$$

$$\begin{bmatrix} \sigma_x \\ \sigma_y \\ \tau_{xy} \end{bmatrix}_{0}^{\text{Bot.}} = \begin{bmatrix} 41,747 \\ -266 \\ -490 \end{bmatrix} \text{lb/in}^2 \quad (E6.9)$$

Top of ply No. 2:

$$\begin{bmatrix} \sigma_x \\ \sigma_y \\ \tau_{xy} \end{bmatrix}_{+45}^{\text{Top}} = \begin{bmatrix} 6,557,237 & 4,555,238 & 4,705,483 \\ 4,555,238 & 6,557,237 & 4,705,483 \\ 4,705,483 & 4,705,483 & 5,163,582 \end{bmatrix} \text{lb/in}^2 \begin{bmatrix} 0.00209 \\ -0.00083 \\ -0.00049 \end{bmatrix}_{+45}$$

$$\begin{bmatrix} \sigma_x \\ \sigma_y \\ \tau_{xy} \end{bmatrix}_{+45}^{\text{Top}} = \begin{bmatrix} 7,618 \\ 1,772 \\ 3,399 \end{bmatrix} \text{lb/in}^2 \quad (E6.10)$$

Since the laminate is symmetric, the stresses on the bottom half of the laminate will mirror those on the top, only with a change of tensile stresses to compressive and compressive to tensile (i.e., a change in sign).

Transforming the stresses into the principal material directions for the +45° ply:

Top of ply No. 2:

$$\begin{bmatrix} \sigma_1 \\ \sigma_2 \\ \tau_{12} \end{bmatrix}_{+45}^{\text{Top}} = \begin{bmatrix} \cos^2 45^\circ & \sin^2 45^\circ & 2 \sin 45^\circ \cos 45^\circ \\ \sin^2 45^\circ & \cos^2 45^\circ & -2 \sin 45^\circ \cos 45^\circ \\ -\sin 45^\circ \cos 45^\circ & \sin 45^\circ \cos 45^\circ & (\cos^2 45^\circ - \sin^2 45^\circ) \end{bmatrix} \begin{bmatrix} 7,618 \\ 1,772 \\ 3,399 \end{bmatrix} \text{lb/in}^2$$

$$\begin{bmatrix} \sigma_1 \\ \sigma_2 \\ \tau_{12} \end{bmatrix}_{+45}^{\text{Top}} = \begin{bmatrix} 8,094 \\ 1,296 \\ -2,923 \end{bmatrix} \text{lb/in}^2 \quad (E6.11)$$

The stresses in the bottom of ply No. 3 will be the mirror of the stresses in the top of ply No. 2, thus, for the bottom of ply No. 3:

$$\begin{bmatrix} \sigma_1 \\ \sigma_2 \\ \tau_{12} \end{bmatrix}_{+45}^{\text{Bot.}} = \begin{bmatrix} -8,094 \\ -1,296 \\ 2,923 \end{bmatrix} \text{ lb/in}^2 . \quad (\text{E6.12})$$

All of the information in example No. 6 can be tabulated:

Strains

Plane	z (in)	ϵ_x	ϵ_y	γ_{xy}	ϵ_1	ϵ_2	γ_{12}
Ply 1 (Top)	+0.01	0.00418	-0.00165	-0.00098	0.00418	-0.00165	-0.00098
Ply 1 (Bot.)	+0.005	0.00209	-0.00083	-0.00049	0.00209	-0.00083	-0.00049
Ply 2 (Top)	+0.005	0.00209	-0.00083	-0.00049	0.00039	0.00088	-0.00292
Ply 2 (Bot.)	0	0	0	0	0	0	0
Ply 3 (Top)	0	0	0	0	0	0	0
Ply 3 (Bot.)	-0.005	-0.00209	0.00083	0.00049	-0.00039	-0.00088	0.00292
Ply 4 (Top)	-0.005	-0.00209	0.00083	0.00049	-0.00209	0.00083	0.00049
Ply 4 (Bot.)	-0.01	-0.00418	0.00165	0.00098	-0.00418	0.00165	0.00098

Stresses

Plane	z (in)	σ_x	σ_y	τ_{xy}	σ_1	σ_2	τ_{12}
Ply 1 (Top)	+0.01	83,500	-518	-976	83,500	-518	-976
Ply 1 (Bot.)	+0.005	41,747	-266	-490	41,747	-266	-490
Ply 2 (Top)	+0.005	7,618	1,772	3,399	8,094	1,296	-2,923
Ply 2 (Bot.)	0	0	0	0	0	0	0
Ply 3 (Top)	0	0	0	0	0	0	0
Ply 3 (Bot.)	-0.005	-7,618	-1,772	-3,399	-8,094	-1,296	2,923
Ply 4 (Top)	-0.005	-41,747	266	490	-41,747	266	490
Ply 4 (Bot.)	-0.01	-83,500	518	976	-83,500	518	976

Since the stresses and strains vary linearly through the thickness of each ply, a diagram of the stresses and strains through the laminate can be made. A few examples follow.

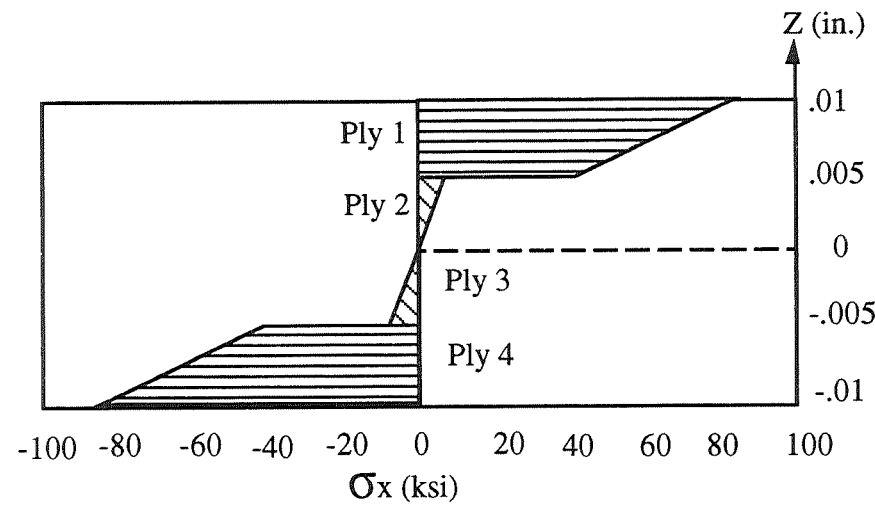
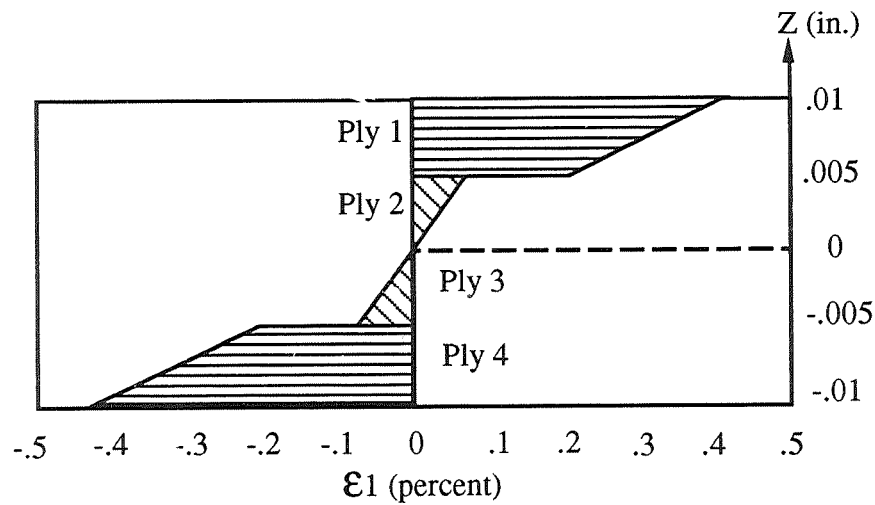
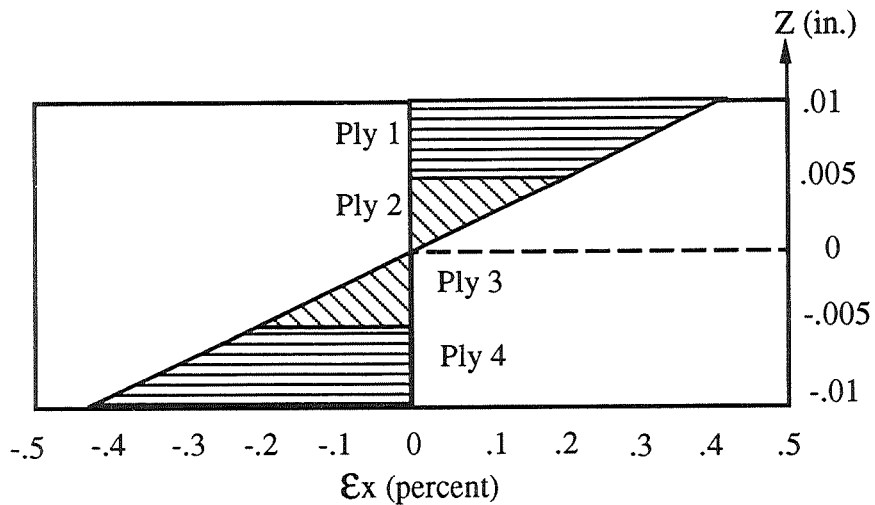

VIII. STRESSES AND STRAINS WITHIN LAMINAE OF AN UNSYMMETRIC LAMINATE

A. Difference From Symmetric Laminates

If the laminate being examined is not symmetric, then additional complexities arise in the material's behavior from that examined in the previous section. The neutral plane of the plate will not coincide with the geometrical midplane of the plate as it did for symmetric plates. Thus, there will be less simplifications, such as knowing the bottom half of a symmetric laminate will consist of a negative mirror image of stresses and strains from the top half due to bending moments. Also, environmental effects may become critical since the plate can warp due to these effects. Coupling now becomes extremely important and can cause very unique mechanical behavior characteristic of anisotropic plates.

B. Example (0/+45)_T Laminate

Example 7:

Consider a 2-ply laminate of AS4/3501-6 with a (0/+45)_T stacking sequence. The lamina properties were given in example 1 as:

$$E_1 = 20,010,000 \text{ lb/in}^2 ,$$

$$E_2 = 1,301,000 \text{ lb/in}^2 ,$$

$$G_{12} = 1,001,000 \text{ lb/in}^2 ,$$

$$\nu_{12} = 0.3 ,$$

$$\nu_{21} = 0.02 ,$$

$$\text{Ply thickness} = 0.005 \text{ in} ,$$

and the resulting values for \bar{Q}_{ij} for the 0° and the +45° plies were given as:

$\bar{Q}_{11}^0 = 20,130,785 \text{ lb/in}^2 ,$	$\bar{Q}_{11}^{+45} = 6,557,237 \text{ lb/in}^2 ,$
$\bar{Q}_{12}^0 = 392,656 \text{ lb/in}^2 ,$	$\bar{Q}_{12}^{+45} = 4,555,238 \text{ lb/in}^2 ,$
$\bar{Q}_{22}^0 = 1,308,853 \text{ lb/in}^2 ,$	$\bar{Q}_{22}^{+45} = 6,557,237 \text{ lb/in}^2 ,$
$\bar{Q}_{16}^0 = 0 ,$	$\bar{Q}_{16}^{+45} = 4,705,483 \text{ lb/in}^2 ,$
$\bar{Q}_{26}^0 = 0 ,$	$\bar{Q}_{26}^{+45} = 4,705,483 \text{ lb/in}^2 ,$
$\bar{Q}_{66}^0 = 1,001,000 \text{ lb/in}^2 ,$	$\bar{Q}_{66}^{+45} = 5,163,582 \text{ lb/in}^2 .$

From equation (53), the A_{ij} are obtained:

$$\begin{aligned}
 A_{11} &= [20,130,785+6,557,237] \text{ lb/in}^2 (0.005 \text{ in}) = 133,440 \frac{\text{lb}}{\text{in}} , \\
 A_{12} &= [392,656+4,555,238] \text{ lb/in}^2 (0.005 \text{ in}) = 24,739 \frac{\text{lb}}{\text{in}} , \\
 A_{22} &= [1,308,853+6,557,237] \text{ lb/in}^2 (0.005 \text{ in}) = 39,330 \frac{\text{lb}}{\text{in}} , \\
 A_{16} &= [0+4,705,483] \text{ lb/in}^2 (0.005 \text{ in}) = 23,527 \frac{\text{lb}}{\text{in}} , \\
 A_{26} &= [0+4,705,483] \text{ lb/in}^2 (0.005 \text{ in}) = 23,527 \frac{\text{lb}}{\text{in}} , \\
 A_{66} &= [1,001,000+5,163,582] \text{ lb/in}^2 (0.005 \text{ in}) = 30,823 \frac{\text{lb}}{\text{in}} .
 \end{aligned}
 \tag{E7.1}$$

From equation (54), the B_{ij} can be determined:

$$\begin{aligned}
 B_{11} &= [20,130,785-6,557,237] \text{ lb/in}^2 (0.005 \text{ in}) (0.0025 \text{ in}) = 170 \text{ lb} , \\
 B_{12} &= [392,656-4,555,238] \text{ lb/in}^2 (0.005 \text{ in}) (0.0025 \text{ in}) = -52 \text{ lb} , \\
 B_{22} &= [1,308,853-6,557,237] \text{ lb/in}^2 (0.005 \text{ in}) (0.0025 \text{ in}) = -66 \text{ lb} , \\
 B_{16} &= [0-4,705,483] \text{ lb/in}^2 (0.005 \text{ in}) (0.0025 \text{ in}) = -59 \text{ lb} , \\
 B_{26} &= [0-4,705,483] \text{ lb/in}^2 (0.005 \text{ in}) (0.0025 \text{ in}) = -59 \text{ lb} , \\
 B_{66} &= [1,001,000-5,163,582] \text{ lb/in}^2 (0.005 \text{ in}) (0.0025 \text{ in}) = -52 \text{ lb} .
 \end{aligned}
 \tag{E7.2}$$

From equation (56), the D_{ij} can be determined:

$$\begin{aligned}
 D_{11} &= \left[20,130,785 + 6,557,237 \right] \text{ lb/in}^2 \left(\frac{(0.005 \text{ in.})^3}{12} + (0.005 \text{ in.})(0.0025 \text{ in.})^2 \right) = 1.11 \text{ in-lb} , \\
 D_{12} &= \left[392,656 + 4,555,238 \right] \text{ lb/in}^2 \left(\frac{(0.005 \text{ in.})^3}{12} + (0.005 \text{ in.})(0.0025 \text{ in.})^2 \right) = 0.206 \text{ in-lb} ,
 \end{aligned}$$

$$\begin{aligned}
 D_{22} &= \left[1,308,853 + 6,557,237 \right] \text{lb/in}^2 \left(\frac{(0.005 \text{ in.})^3}{12} + (0.005 \text{ in.})(0.0025 \text{ in.})^2 \right) = 0.328 \text{ in-lb} , \\
 D_{16} &= \left[0 + 4,705,483 \right] \text{lb/in}^2 \left(\frac{(0.005 \text{ in.})^3}{12} + (0.005 \text{ in.})(0.0025 \text{ in.})^2 \right) = 0.196 \text{ in-lb} , \\
 D_{26} &= \left[0 + 4,705,483 \right] \text{lb/in}^2 \left(\frac{(0.005 \text{ in.})^3}{12} + (0.005 \text{ in.})(0.0025 \text{ in.})^2 \right) = 0.196 \text{ in-lb} , \\
 D_{66} &= \left[1,001,000 + 5,163,582 \right] \text{lb/in}^2 \left(\frac{(0.005 \text{ in.})^3}{12} + (0.005 \text{ in.})(0.0025 \text{ in.})^2 \right) = 0.257 \text{ in-lb} .
 \end{aligned}
 \tag{E7.3}$$

Find the stresses and strains in each of the two plies given a stress resultant in the x -direction of 250 lb/in. The primed matrices must be obtained from equations (51) and (53):

$$\begin{aligned}
 [A^*] &= \begin{bmatrix} 8.80 & -2.80 & -4.60 \\ -2.80 & 47.7 & -34.3 \\ -4.60 & -34.3 & 62.1 \end{bmatrix} \times 10^{-6} \frac{\text{in}}{\text{lb}} , \\
 [B^*] &= \begin{bmatrix} -1.91 & 0.0014 & 0.115 \\ 0.933 & 0.979 & 0.866 \\ 02.66 & 1.16 & 0.934 \end{bmatrix} \times 10^{-3} \text{ in} , \\
 [C^*] &= \begin{bmatrix} 1.91 & -0.933 & -2.66 \\ -0.0014 & -0.979 & -1.16 \\ -0.115 & -0.866 & -0.934 \end{bmatrix} \times 10^{-3} \text{ in} , \\
 [D^*] &= \begin{bmatrix} 0.580 & 0.087 & 0.115 \\ 0.087 & 0.195 & 0.078 \\ 0.115 & 0.078 & 0.151 \end{bmatrix} \text{ in-lb} .
 \end{aligned}$$

Therefore,

$$[A'] = \begin{bmatrix} 17.0 & -3.07 & -11.6 \\ -3.07 & 54.6 & -25.9 \\ -11.6 & -25.9 & 77.7 \end{bmatrix} \times 10^{-6} \frac{\text{in}}{\text{lb}} ,$$

$$[B'] = \begin{bmatrix} -4.07 & 0.353 & 3.68 \\ 0.368 & 3.38 & 3.72 \\ 3.75 & 3.72 & 1.43 \end{bmatrix} \times 10^{-3} \frac{\text{in}}{\text{lb}} ,$$

$$[C'] = \begin{bmatrix} -4.07 & 0.368 & 3.75 \\ 0.353 & 3.38 & 3.72 \\ 3.68 & 3.72 & 1.43 \end{bmatrix} \times 10^{-3} \frac{\text{in}}{\text{lb}} ,$$

$$[D'] = \begin{bmatrix} 2.05 & -0.366 & -1.37 \\ -0.366 & 6.53 & -3.09 \\ -1.37 & -3.09 & 9.27 \end{bmatrix} \frac{\text{in-lb}}{\text{in}} .$$

Using the constitutive equation (52), the midplane strains and plate curvatures can be found.

$$\varepsilon_x^0 = A'_{11} N_x = 17.0 \times 10^{-6} \frac{\text{in}}{\text{lb}} \left(250 \frac{\text{lb}}{\text{in}} \right) = 0.00425 ,$$

$$\varepsilon_y^0 = A'_{12} N_x = -3.07 \times 10^{-6} \frac{\text{in}}{\text{lb}} \left(250 \frac{\text{lb}}{\text{in}} \right) = -0.00077 ,$$

$$\gamma_{xy}^0 = A'_{16} N_x = -11.6 \times 10^{-6} \frac{\text{in}}{\text{lb}} \left(250 \frac{\text{lb}}{\text{in}} \right) = -0.0029 ,$$

(E7.4)

$$K_x = C'_{11} N_x = -4.07 \times 10^{-3} \frac{\text{in}}{\text{lb}} \left(250 \frac{\text{lb}}{\text{in}} \right) = -1.02 \frac{\text{in}}{\text{in}} ,$$

$$K_y = C'_{12} N_x = 0.353 \times 10^{-3} \frac{\text{in}}{\text{lb}} \left(250 \frac{\text{lb}}{\text{in}} \right) = 0.088 \frac{\text{in}}{\text{in}} ,$$

$$K_{xy} = C'_{16} N_x = 3.68 \times 10^{-3} \frac{\text{in}}{\text{lb}} \left(250 \frac{\text{lb}}{\text{in}} \right) = 0.92 \frac{\text{in}}{\text{in}} .$$

The strains throughout the laminate can now be calculated from equation (30). Use the following diagram for clarity;

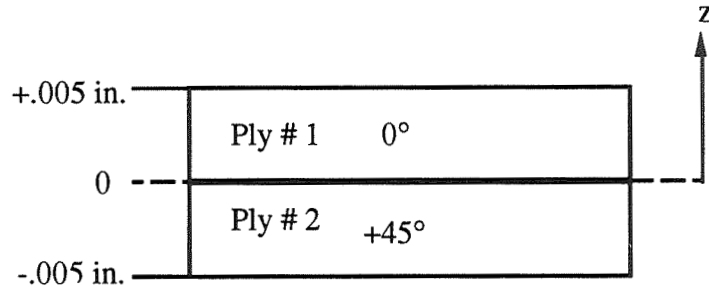

At the top of ply No. 1:

$$\begin{bmatrix} \epsilon_x \\ \epsilon_y \\ \gamma_{xy} \end{bmatrix}_0^{\text{Top}} = \begin{bmatrix} 0.00425 \\ -0.00077 \\ -0.0029 \end{bmatrix} + 0.005 \text{ in} \begin{bmatrix} -1.02 \\ 0.088 \\ 0.92 \end{bmatrix} \frac{1}{\text{in}} = \begin{bmatrix} -0.00085 \\ -0.00033 \\ 0.0017 \end{bmatrix} \quad . \quad (\text{E7.5})$$

At the bottom of ply No. 1:

$$\begin{bmatrix} \epsilon_x \\ \epsilon_y \\ \gamma_{xy} \end{bmatrix}_0^{\text{Bot}} = \begin{bmatrix} 0.00425 \\ -0.00077 \\ -0.0029 \end{bmatrix} + 0 \text{ in} \begin{bmatrix} -1.02 \\ 0.088 \\ 0.92 \end{bmatrix} \frac{1}{\text{in}} = \begin{bmatrix} 0.00425 \\ -0.00077 \\ -0.0029 \end{bmatrix} \quad . \quad (\text{E7.6})$$

At the top of ply No. 2:

$$\begin{bmatrix} \epsilon_x \\ \epsilon_y \\ \gamma_{xy} \end{bmatrix}_{+45}^{\text{Top}} = \begin{bmatrix} 0.00425 \\ -0.00077 \\ -0.0029 \end{bmatrix} + 0 \text{ in} \begin{bmatrix} -1.02 \\ 0.088 \\ 0.92 \end{bmatrix} \frac{1}{\text{in}} = \begin{bmatrix} 0.00425 \\ -0.00077 \\ -0.0029 \end{bmatrix} \quad . \quad (\text{E7.7})$$

At the bottom of ply No. 2:

$$\begin{bmatrix} \epsilon_x \\ \epsilon_y \\ \gamma_{xy} \end{bmatrix}_{+45}^{\text{Bot}} = \begin{bmatrix} 0.00425 \\ -0.00077 \\ -0.0029 \end{bmatrix} + 0.005 \text{ in} \begin{bmatrix} -1.02 \\ 0.088 \\ 0.92 \end{bmatrix} \frac{1}{\text{in}} = \begin{bmatrix} 0.0094 \\ -0.0012 \\ -0.0075 \end{bmatrix} \quad . \quad (\text{E7.8})$$

Transforming the strains in the + 45° ply into the principal material directions.

Top of ply No. 2:

$$\begin{bmatrix} \varepsilon_1 \\ \varepsilon_2 \\ \frac{\gamma_{12}}{2} \end{bmatrix}_{+45}^{\text{Top}} = \begin{bmatrix} \cos^2 45^\circ & \sin^2 45^\circ & 2 \sin 45^\circ \cos 45^\circ \\ \sin^2 45^\circ & \cos^2 45^\circ & -2 \sin 45^\circ \cos 45^\circ \\ -\sin 45^\circ \cos 45^\circ & \sin 45^\circ \cos 45^\circ & (\cos^2 45^\circ - \sin^2 45^\circ) \end{bmatrix} \begin{bmatrix} 0.00425 \\ -0.00077 \\ \frac{-0.0029}{2} \end{bmatrix} \quad (E7.9)$$

$$\varepsilon_1^{+45} = 0.00029 ; \quad \varepsilon_2^{+45} = 0.00319 ; \quad \gamma_{12}^{+45} = -0.00502$$

Bottom of ply No. 2:

$$\begin{bmatrix} \varepsilon_1 \\ \varepsilon_2 \\ \frac{\gamma_{12}}{2} \end{bmatrix}_{+45}^{\text{Bot.}} = \begin{bmatrix} \cos^2 45^\circ & \sin^2 45^\circ & 2 \sin 45^\circ \cos 45^\circ \\ \sin^2 45^\circ & \cos^2 45^\circ & -2 \sin 45^\circ \cos 45^\circ \\ -\sin 45^\circ \cos 45^\circ & \sin 45^\circ \cos 45^\circ & (\cos^2 45^\circ - \sin^2 45^\circ) \end{bmatrix} \begin{bmatrix} 0.0094 \\ -0.0012 \\ \frac{-0.0075}{2} \end{bmatrix} \quad (E7.10)$$

$$\varepsilon_1^{+45} = 0.00035 ; \quad \varepsilon_2^{+45} = 0.00785 ; \quad \gamma_{12}^{+45} = -0.0106$$

Putting these values of strain into tabular format:

Strains

Plane	z (in)	ε_x	ε_y	γ_{xy}	ε_1	ε_2	γ_{12}
Ply 1 (Top)	+0.005	-0.00085	-0.00033	0.0017	-0.00085	-0.00033	0.0017
Ply 1 (Bot.)	0	0.00425	-0.00077	-0.0029	0.00425	-0.00077	-0.0029
Ply 2 (Top)	0	0.00425	-0.00077	-0.0029	0.00029	0.00319	-0.00502
Ply 2 (Bot.)	-0.005	0.0094	-0.0012	-0.0075	0.00035	0.00785	-0.0106

A diagram of the through-the-thickness strain in the x-direction follows:

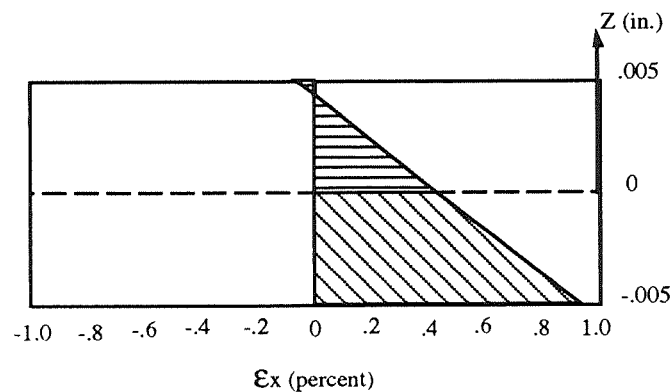

Note that although only a tensile stress is applied to the plate, a small amount of compressive strain is produced in the outer fibers of part of the 0° ply. This is due to the B_{ij} terms which relate midplane strains to plate curvatures (i.e., due to the nonsymmetry, the plate is bending even though no bending moment is applied). As can be seen from the diagram, the plate is curving into the 0° fiber direction.

Example 8:

Consider an applied moment of 2.5 inch-lb/inch in the 0° fiber direction. The constitutive equation is:

$$\begin{bmatrix} \varepsilon_x^0 \\ \varepsilon_y^0 \\ \gamma_{xy}^0 \\ K_x \\ K_y \\ K_{xy} \end{bmatrix} = \begin{bmatrix} A'_{11} & A'_{12} & A'_{16} & 0 & 0 & 0 \\ A'_{12} & A'_{22} & A'_{26} & 0 & 0 & 0 \\ A'_{16} & A'_{26} & A'_{66} & 0 & 0 & 0 \\ 0 & 0 & 0 & D'_{11} & D'_{12} & D'_{16} \\ 0 & 0 & 0 & D'_{12} & D'_{22} & D'_{26} \\ 0 & 0 & 0 & D'_{16} & D'_{26} & D'_{66} \end{bmatrix} \begin{bmatrix} 0 \\ 0 \\ 0 \\ M_x \\ 0 \\ 0 \end{bmatrix} \quad (E8.1)$$

From this the midplane strains and plate curvatures can be found.

$$\begin{aligned} \varepsilon_x^0 &= B'_{11} M_x = -0.00407 \frac{\text{in-lb}}{\text{lb}} \left(2.5 \frac{\text{in-lb}}{\text{in}} \right) = -0.0102 \\ \varepsilon_y^0 &= B'_{12} M_x = 0.000368 \frac{\text{in-lb}}{\text{lb}} \left(2.5 \frac{\text{in-lb}}{\text{in}} \right) = 0.00092 \\ \gamma_{xy}^0 &= B'_{16} M_x = 0.00375 \frac{\text{in-lb}}{\text{lb}} \left(2.5 \frac{\text{in-lb}}{\text{in}} \right) = 0.00938 \\ K_x &= D'_{11} M_x = 2.05 \frac{\text{in-lb}}{\text{in-lb}} \left(2.5 \frac{\text{in-lb}}{\text{in}} \right) = 5.1 \frac{1}{\text{in}} \\ K_y &= D'_{12} M_x = -0.366 \frac{\text{in-lb}}{\text{in-lb}} \left(2.5 \frac{\text{in-lb}}{\text{in}} \right) = -0.92 \frac{1}{\text{in}} \\ K_{xy} &= D'_{16} M_x = -1.37 \frac{\text{in-lb}}{\text{in-lb}} \left(2.5 \frac{\text{in-lb}}{\text{in}} \right) = -3.43 \frac{1}{\text{in}} \end{aligned} \quad (E8.2)$$

Using equation (30), the strains through each of the two plies can be calculated.

For the top of the 0° ply:

$$\begin{bmatrix} \varepsilon_x \\ \varepsilon_y \\ \gamma_{xy} \end{bmatrix}_0^{\text{Top}} = \begin{bmatrix} -0.0102 \\ 0.00092 \\ 0.00938 \end{bmatrix} + 0.005 \text{ in} \begin{bmatrix} 5.1 \\ -0.92 \\ -03.43 \end{bmatrix} \frac{1}{\text{in}} = \begin{bmatrix} 0.0153 \\ -0.00368 \\ -0.0078 \end{bmatrix} . \quad (\text{E8.3})$$

For the bottom of the 0° ply (which will be the same as the top of the +45° ply since the laminate axes are being used, not the principal material axes for a specific ply):

$$\begin{bmatrix} \varepsilon_x \\ \varepsilon_y \\ \gamma_{xy} \end{bmatrix}_0^{\text{Bot}} = \begin{bmatrix} -0.0102 \\ 0.00092 \\ 0.00938 \end{bmatrix} + 0 \text{ in} \begin{bmatrix} 5.1 \\ -0.92 \\ -03.43 \end{bmatrix} \frac{1}{\text{in}} = \begin{bmatrix} -0.0102 \\ 0.00092 \\ 0.00938 \end{bmatrix} = \begin{bmatrix} \varepsilon_x \\ \varepsilon_y \\ \gamma_{xy} \end{bmatrix}_{+45}^{\text{Top}} . \quad (\text{E8.4})$$

For the bottom of the +45° ply:

$$\begin{bmatrix} \varepsilon_x \\ \varepsilon_y \\ \gamma_{xy} \end{bmatrix}_{+45}^{\text{Bot}} = \begin{bmatrix} -0.0102 \\ 0.00092 \\ 0.00938 \end{bmatrix} - 0.005 \text{ in} \begin{bmatrix} 5.1 \\ -0.92 \\ -03.43 \end{bmatrix} \frac{1}{\text{in}} = \begin{bmatrix} -0.0357 \\ 0.00552 \\ 0.0265 \end{bmatrix} . \quad (\text{E8.5})$$

Transforming the strains in the +45° ply into principal material directions:

$$\begin{bmatrix} \varepsilon_1 \\ \varepsilon_2 \\ \frac{\gamma_{12}}{2} \end{bmatrix}_{+45}^{\text{Top}} = \begin{bmatrix} \cos^2 45^\circ & \sin^2 45^\circ & 2 \sin 45^\circ \cos 45^\circ \\ \sin^2 45^\circ & \cos^2 45^\circ & -2 \sin 45^\circ \cos 45^\circ \\ -\sin 45^\circ \cos 45^\circ & \sin 45^\circ \cos 45^\circ & (\cos^2 45^\circ - \sin^2 45^\circ) \end{bmatrix} \begin{bmatrix} -0.0102 \\ 0.00092 \\ \frac{0.00938}{2} \end{bmatrix} , \quad (\text{E8.6})$$

$$\varepsilon_1^{+45} = 0.000 \quad ; \quad \varepsilon_2^{+45} = -0.00933 \quad ; \quad \gamma_{12}^{+45} = 0.0111$$

$$\begin{bmatrix} \varepsilon_1 \\ \varepsilon_2 \\ \frac{\gamma_{12}}{2} \end{bmatrix}_{+45}^{\text{Bot}} = \begin{bmatrix} \cos^2 45^\circ & \sin^2 45^\circ & 2 \sin 45^\circ \cos 45^\circ \\ \sin^2 45^\circ & \cos^2 45^\circ & -2 \sin 45^\circ \cos 45^\circ \\ -\sin 45^\circ \cos 45^\circ & \sin 45^\circ \cos 45^\circ & (\cos^2 45^\circ - \sin^2 45^\circ) \end{bmatrix} \begin{bmatrix} -0.0357 \\ 0.00052 \\ \frac{0.0265}{2} \end{bmatrix} . \quad (\text{E8.7})$$

$$\varepsilon_1^{+45} = 0.00184 \quad ; \quad \varepsilon_2^{+45} = -0.0283 \quad ; \quad \gamma_{12}^{+45} = 0.0412$$

Putting the above values of strain into tabular form:

Strains

Plane	z (in.)	ϵ_x	ϵ_y	γ_{xy}	ϵ_1	ϵ_2	γ_{12}
Ply 1 (Top)	+0.005	0.0153	-0.00368	-0.0078	-0.00085	-0.00033	0.0017
Ply 1 (Bot.)	0	-0.0102	0.00092	0.00938	0.00425	-0.00077	-0.0029
Ply 2 (Top)	0	-0.0102	0.00092	0.00938	0	-0.00933	0.0111
Ply 2 (Bot.)	-0.005	-0.0357	0.00552	0.0265	-0.00184	-0.0283	0.0412

A diagram of the through-the-thickness strain in the x-direction follows:

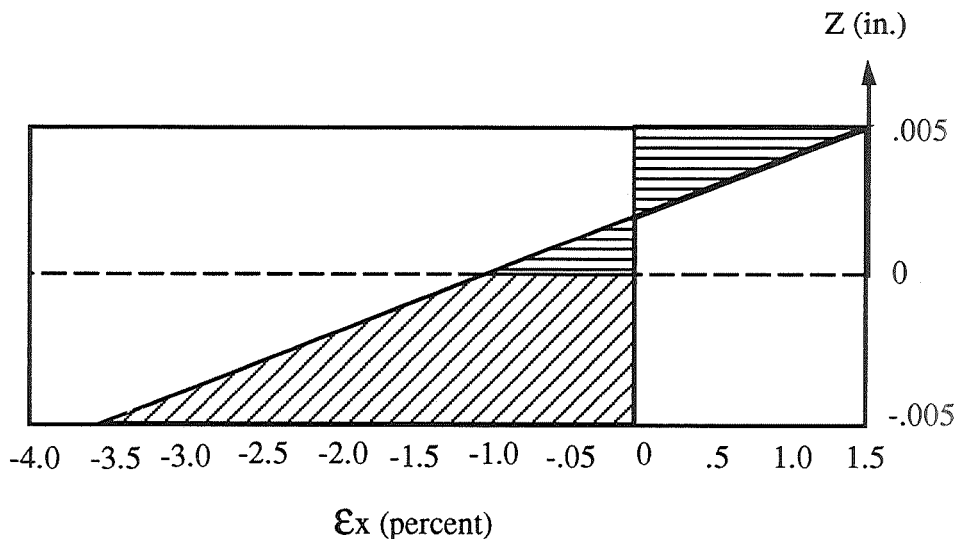

Note that at the geometric midplane, the strain is not zero but -1.02 percent, even though only a bending moment has been applied. This is due to the bending-extension coupling that is present in this unsymmetric laminate. The plane of zero strain in the x-direction can be determined by setting ϵ_x equal to zero in equation(30) and solving for z:

$$\begin{bmatrix} 0 \\ \epsilon_y \\ \gamma_{xy} \end{bmatrix} = \begin{bmatrix} -0.0102 \\ 0.00092 \\ 0.00938 \end{bmatrix} + z \begin{bmatrix} 5.1 \\ -0.92 \\ -3.43 \end{bmatrix} \frac{1}{\text{in}} \tag{E8.8}$$

$$\Rightarrow 0 = -0.0102 + \left(5.1 \frac{1}{\text{in}}\right) z \Rightarrow z = 0.002 \text{ in}$$

Thus, at $z = 0.002 \text{ in}$, the x-direction strain is zero for this example. A diagram of the through-the-thickness strain along the fibers in each ply follows:

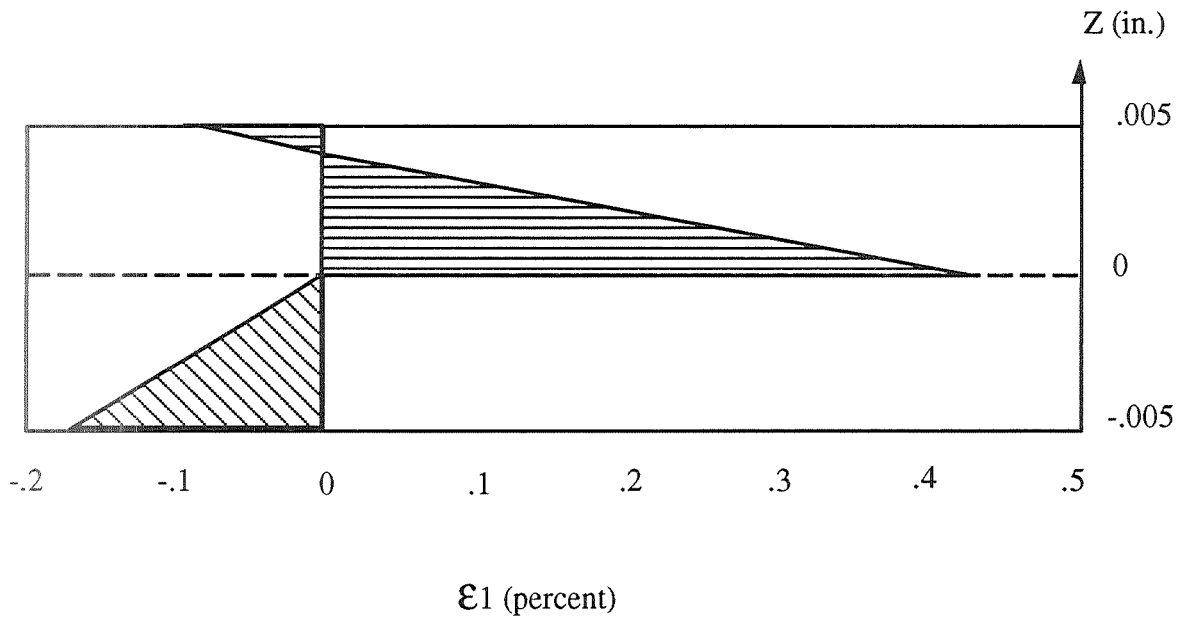

C. Determination of the Neutral Plane

The plane of zero strain for any direction in an unsymmetric laminate can be calculated from equations (52) and (30). For pure bending in the x -direction:

$$\begin{bmatrix} 0 \\ 0 \\ 0 \end{bmatrix} = \begin{bmatrix} B'_{11} M_x \\ B'_{12} M_x \\ B'_{16} M_x \end{bmatrix} + z \begin{bmatrix} D'_{11} M_x \\ D'_{12} M_x \\ D'_{16} M_x \end{bmatrix} \frac{1}{\text{in}} \quad , \quad (96)$$

$$z = \frac{-B'_{11}}{D'_{11}} \quad \text{for the } \epsilon_x = 0 \text{ plane} \quad ,$$

$$z = \frac{-B'_{12}}{D'_{12}} \quad \text{for the } \epsilon_y = 0 \text{ plane} \quad , \quad (97)$$

$$z = \frac{-B'_{16}}{D'_{16}} \quad \text{for the } \gamma_{xy} = 0 \text{ plane} \quad .$$

For example No. 8, these values of z are;

$$\begin{aligned} \text{For the } \varepsilon_x = 0 \text{ plane ; } z &= \frac{0.00407 \frac{\text{lb}}{\text{in-lb}}}{2.05 \frac{\text{lb}}{\text{in-lb}}} = 0.002 \text{ in} \\ \text{For the } \varepsilon_y = 0 \text{ plane ; } z &= \frac{-0.000353 \frac{\text{lb}}{\text{in-lb}}}{-0.366 \frac{\text{lb}}{\text{in-lb}}} = 0.00096 \text{ in} \\ \text{For the } \gamma_{xy} = 0 \text{ plane ; } z &= \frac{-0.00368 \frac{\text{lb}}{\text{in-lb}}}{-1.37 \frac{\text{lb}}{\text{in-lb}}} = 0.0027 \text{ in} \end{aligned} \quad (98)$$

The general form of equation (96) is:

For the $\varepsilon_x = 0$ plane;

$$0 = B'_{11}M_x + B'_{12}M_y + B'_{16}M_{xy} + z(D'_{11}M_x + D'_{12}M_y + D'_{16}M_{xy}) \frac{\text{lb}}{\text{in}} \quad (99)$$

For the $\varepsilon_y = 0$ plane;

$$0 = B'_{12}M_x + B'_{22}M_y + B'_{26}M_{xy} + z(D'_{12}M_x + D'_{22}M_y + D'_{26}M_{xy}) \frac{\text{lb}}{\text{in}} \quad (100)$$

For the $\gamma_{xy} = 0$ plane;

$$0 = B'_{16}M_x + B'_{26}M_y + B'_{66}M_{xy} + z(D'_{16}M_x + D'_{26}M_y + D'_{66}M_{xy}) \frac{\text{lb}}{\text{in}} \quad (101)$$

It can be seen that if only one moment resultant is acting on the laminate then the planes of zero strains (the neutral planes) will not depend on the value. However, if more than one moment resultant is being applied to the plate, then the magnitude of these moment resultants will determine where the neutral planes are located. Regardless, equations (99), (100), and (101) can be used to find the planes of zero strain for an unsymmetric laminate subjected to bending moments.

Example 9:

Consider a square laminated plate of AS4/3501-6 with a stacking sequence of $[+45, 0, 90]_T$. Find the stresses and strains at room temperature (70 °F) in each ply in both the laminate and material directions due to thermal processing effects. The material was processed at 350 °F. Assume no moisture effects.

The lamina properties are:

$$E_1 = 20,010,000 \text{ lb/in}^2 ,$$

$$E_2 = 1,301,000 \text{ lb/in}^2 ,$$

$$G_{12} = 1,001,000 \text{ lb/in}^2 ,$$

$$\nu_{12} = 0.3 ,$$

$$\nu_{21} = 0.02 ,$$

$$\alpha_1 = -0.072 \times 10^{-6} \frac{1}{\text{F}^\circ} ,$$

$$\alpha_2 = 32.4 \times 10^{-6} \frac{1}{\text{F}^\circ} ,$$

$$\text{Ply thickness} = 0.005 \text{ in} .$$

From equation (10), the reduced stiffnesses can be calculated:

$$Q_{11} = \frac{E_1}{1 - \nu_{12}\nu_{21}} = \frac{20,010,000 \text{ lb/in}^2}{1 - (0.3)(0.02)} = 20,130,785 \text{ lb/in}^2 ,$$

$$Q_{22} = \frac{E_2}{1 - \nu_{12}\nu_{21}} = \frac{1,301,000 \text{ lb/in}^2}{1 - (0.3)(0.02)} = 1,308,853 \text{ lb/in}^2 ,$$

$$Q_{12} = \frac{\nu_{12}E_2}{1 - \nu_{12}\nu_{21}} = \frac{(0.3)(1,301,000 \text{ lb/in}^2)}{1 - (0.3)(0.02)} = 392,656 \text{ lb/in}^2 ,$$

$$Q_{66} = 1,001,000 \text{ lb/in}^2 .$$
(E9.1)

From equation (22); for the 0° plies:

$$\bar{Q}_{11}^0 = 20,130,785 \text{ lb/in}^2 ,$$

$$\bar{Q}_{12}^0 = 392,656 \text{ lb/in}^2 ,$$

$$\bar{Q}_{22}^0 = 1,308,853 \text{ lb/in}^2 ,$$

$$\bar{Q}_{16}^0 = 0 ,$$

$$\bar{Q}_{26}^0 = 0 ,$$

$$\bar{Q}_{66}^0 = 1,001,000 \text{ lb/in}^2 .$$
(E9.2)

For the +45° ply:

$$\begin{aligned}
 \bar{Q}_{11}^{+45} &= (20,130,785 \text{ lb/in}^2)(0.707)^4 + 2 \left((392,656 \text{ lb/in}^2 + 2(1,001,000 \text{ lb/in}^2)) (0.707)^2 (0.707)^2 \right. \\
 &\quad \left. + (1,308,853 \text{ lb/in}^2)(0.707)^4 \right) = 6,557,237 \text{ lb/in}^2 , \\
 \bar{Q}_{12}^{+45} &= \left((20,130,785 \text{ lb/in}^2 + 1,308,853 \text{ lb/in}^2 - 4(1,001,000 \text{ lb/in}^2)) (0.707)^2 (0.707)^2 \right. \\
 &\quad \left. + 392,656 \text{ lb/in}^2 (0^4 + (0.707)^4) \right) = 4,555,238 \text{ lb/in}^2 , \\
 \bar{Q}_{22}^{+45} &= (20,130,785 \text{ lb/in}^2)(0.707)^4 + 2 \left((392,656 \text{ lb/in}^2 + 2(1,001,000 \text{ lb/in}^2)) (0.707)^2 (0.707)^2 \right. \\
 &\quad \left. + (1,308,853 \text{ lb/in}^2)(0.707)^4 \right) = 6,557,237 \text{ lb/in}^2 , \\
 \bar{Q}_{16}^{+45} &= \left(20,130,785 \text{ lb/in}^2 - 392,656 \text{ lb/in}^2 - 2(1,001,000 \text{ lb/in}^2) \right) (0.707)^3 (0.707) \\
 &+ \left(392,656 \text{ lb/in}^2 - 1,308,853 \text{ lb/in}^2 + 2(1,001,000 \text{ lb/in}^2) \right) (0.707)(0.707)^3 = 4,705,483 \text{ lb/in}^2 , \\
 \bar{Q}_{26}^{+45} &= \left(20,130,785 \text{ lb/in}^2 - 392,656 \text{ lb/in}^2 - 2(1,001,000 \text{ lb/in}^2) \right) (0.707)^3 (0.707) \\
 &+ \left(392,656 \text{ lb/in}^2 - 1,308,853 \text{ lb/in}^2 + 2(1,001,000 \text{ lb/in}^2) \right) (0.707)(0.707)^3 = 4,705,483 \text{ lb/in}^2 , \\
 \bar{Q}_{66}^{+45} &= \left(20,130,785 \text{ lb/in}^2 + 1,308,853 \text{ lb/in}^2 - 2(392,656 \text{ lb/in}^2 + 1,001,000 \text{ lb/in}^2) \right) (0.707)^2 (0.707)^2 \\
 &\quad + 1,001,000 \text{ lb/in}^2 \left((0.707)^4 + (0.707)^4 \right) = 5,163,582 \text{ lb/in}^2 .
 \end{aligned}$$

(E9.3)

For the 90° ply:

$$\begin{aligned}
 \bar{Q}_{11}^{90} &= 1,308,853 \text{ lb/in}^2 , \\
 \bar{Q}_{12}^{90} &= 392,656 \text{ lb/in}^2 , \\
 \bar{Q}_{22}^{90} &= 20,130,785 \text{ lb/in}^2 , \\
 \bar{Q}_{16}^{90} &= 0 , \\
 \bar{Q}_{26}^{90} &= 0 , \\
 \bar{Q}_{66}^{90} &= 1,001,000 \text{ lb/in}^2 .
 \end{aligned}$$

(E9.4)

From equation (53):

$$\begin{aligned}
 A_{11} &= \left[20,130,785 + 6,557,237 + 1,308,853 \right] \text{lb/in}^2 (0.005 \text{ in}) = 139,984 \frac{\text{lb}}{\text{in}} , \\
 A_{12} &= \left[392,656 + 4,555,238 + 392,656 \right] \text{lb/in}^2 (0.005 \text{ in}) = 26,703 \frac{\text{lb}}{\text{in}} , \\
 A_{22} &= \left[1,308,853 + 6,557,237 + 20,130,785 \right] \text{lb/in}^2 (0.005 \text{ in}) = 139,984 \frac{\text{lb}}{\text{in}} , \\
 A_{16} &= \left[4,705,483 \right] \text{lb/in}^2 (0.005 \text{ in}) = 23,527 \frac{\text{lb}}{\text{in}} , \\
 A_{26} &= \left[4,705,483 \right] \text{lb/in}^2 (0.005 \text{ in}) = 23,527 \frac{\text{lb}}{\text{in}} , \\
 A_{66} &= \left[1,001,000 + 5,163,582 + 1,001,000 \right] \text{lb/in}^2 (0.005 \text{ in}) = 35,828 \frac{\text{lb}}{\text{in}} .
 \end{aligned} \tag{E9.5}$$

From equation (54); the B_{ij} 's will be:

$$\begin{aligned}
 B_{11} &= [6,557,237(0.005) - 1,308,853(0.005)] \frac{\text{lb}}{\text{in}} (0.005 \text{ in}) = 131.2 \text{ lb} , \\
 B_{12} &= [4,555,238(0.005) - 392,656(0.005)] \frac{\text{lb}}{\text{in}} (0.005 \text{ in}) = 104 \text{ lb} , \\
 B_{22} &= [6,557,237(0.005) - 20,130,785(0.005)] \frac{\text{lb}}{\text{in}} (0.005 \text{ in}) = -339.4 \text{ lb} , \\
 B_{16} &= [4,705,483] \text{lb/in}^2 (0.005 \text{ in}) (0.005 \text{ in}) = 117.6 \text{ lb} , \\
 B_{26} &= [4,705,483] \text{lb/in}^2 (0.005 \text{ in}) (0.005 \text{ in}) = 117.6 \text{ lb} , \\
 B_{66} &= [5,163,582(0.005) - 1,001,000(0.005)] \frac{\text{lb}}{\text{in}} (0.005 \text{ in}) = 104 \text{ lb} .
 \end{aligned} \tag{E9.6}$$

From equation (56); the D_{ij} 's will be:

$$D_{11} = \left[\begin{array}{l} 6,557,237 \left(\frac{(0.005)^3}{12} + (0.005)(0.005)^2 \right) + 20,130,785 \left(\frac{(0.005)^3}{12} + 0 \right) \\ + 1,308,853 \left(\frac{(0.005)^3}{12} + (0.005)(0.005)^2 \right) \end{array} \right] = 1.275 \text{ in-lb} ,$$

$$D_{12} = \left[\begin{array}{l} 4,555,238 \left(\frac{(0.005)^3}{12} + (0.005)(0.005)^2 \right) + 392,656 \left(\frac{(0.005)^3}{12} + 0 \right) \\ + 392,656 \left(\frac{(0.005)^3}{12} + (0.005)(-0.005)^2 \right) \end{array} \right] = 0.674 \text{ in-lb} ,$$

$$D_{22} = \left[\begin{array}{l} 6,557,237 \left(\frac{(0.005)^3}{12} + (0.005)(0.005)^2 \right) + 1,308,853 \left(\frac{(0.005)^3}{12} + 0 \right) \\ + 20,130,785 \left(\frac{(0.005)^3}{12} + (0.005)(-0.005)^2 \right) \end{array} \right] = 3.628 \text{ in-lb} ,$$

$$D_{16} = \left[4,705,483 \left(\frac{(0.005)^3}{12} + (0.005)(0.005)^2 \right) \right] = 0.637 \text{ in-lb} ,$$

$$D_{26} = \left[4,705,483 \left(\frac{(0.005)^3}{12} + (0.005)(0.005)^2 \right) \right] = 0.637 \text{ in-lb} ,$$

$$D_{66} = \left[\begin{array}{l} 5,163,582 \left(\frac{(0.005)^3}{12} + (0.005)(0.005)^2 \right) + 1,001,000 \left(\frac{(0.005)^3}{12} + 0 \right) \\ + 1,001,000 \left(\frac{(0.005)^3}{12} + (0.005)(-0.005)^2 \right) \end{array} \right] = 0.845 \text{ in-lb} .$$

(E9.7)

The extensional stiffness $[A]$, coupling stiffness $[B]$, and bending stiffness $[D]$ matrices are:

$$[A] = \begin{bmatrix} 139,984 & 26,703 & 23,527 \\ 26,703 & 139,984 & 23,527 \\ 23,527 & 23,527 & 35,828 \end{bmatrix} \frac{\text{lb}}{\text{in}} ,$$

$$[B] = \begin{bmatrix} 131.2 & 104 & 117.6 \\ 104 & -339.4 & 117.6 \\ 117.6 & 117.6 & 104 \end{bmatrix} \text{lb} ,$$

$$[D] = \begin{bmatrix} 1.275 & 0.674 & 0.637 \\ 0.674 & 3.628 & 0.637 \\ 0.637 & 0.637 & 0.845 \end{bmatrix} \text{in-lb} .$$

The fully inverted form of the constitutive equations is needed. First, the partially inverted form is given by equation (51):

$$[A^*] = [A]^{-1} = \begin{bmatrix} 8.1 & -0.73 & -4.8 \\ -0.73 & 8.1 & -4.8 \\ -4.8 & -4.8 & 34.3 \end{bmatrix} \times 10^{-6} \frac{\text{in}}{\text{lb}} ,$$

$$[B^*] = -[A]^{-1}[B] = \begin{bmatrix} -4.22 & -5.26 & -3.67 \\ -1.82 & 33.9 & -3.67 \\ -29.05 & -51.6 & -24.38 \end{bmatrix} \times 10^{-4} \text{in} ,$$

$$[C^*] = [B][A]^{-1} = \begin{bmatrix} 4.22 & 1.82 & 29.05 \\ 5.26 & -33.9 & 51.6 \\ 3.67 & 3.67 & 24.38 \end{bmatrix} \times 10^{-4} \text{in} ,$$

$$[D^*] = [D] - [B][A]^{-1}[B] = \begin{bmatrix} 0.859 & 0.350 & 0.264 \\ 0.350 & 1.816 & 0.437 \\ 0.264 & 0.437 & 0.505 \end{bmatrix} \text{in-lb} .$$

The fully inverted form can now be determined from equation (52a):

$$[A'] = [A^*] - [B^*][D^*]^{-1}[C^*] = \begin{bmatrix} 8.5 & -0.91 & -2.175 \\ -0.91 & 18.1 & -10.3 \\ -2.175 & -10.3 & 55.2 \end{bmatrix} \times 10^{-6} \frac{\text{in}}{\text{lb}} ,$$

$$[B'] = [B^*][D^*]^{-1} = \begin{bmatrix} -299 & -120 & -467 \\ -427 & 2,614 & -2,765 \\ -1,932 & -1,959 & -2,124 \end{bmatrix} \times 10^{-6} \frac{\text{in}}{\text{lb}} ,$$

$$[C'] = -[D^*]^{-1}[C^*] = \begin{bmatrix} -299 & -427 & -1,932 \\ -120 & 2,614 & -1,959 \\ -467 & -2,764 & -2,124 \end{bmatrix} \times 10^{-6} \frac{\text{in}}{\text{lb}} ,$$

$$[D'] = [D^*]^{-1} = \begin{bmatrix} 1.41 & -0.119 & -0.633 \\ -0.119 & 0.706 & -0.548 \\ -0.633 & -0.548 & 2.79 \end{bmatrix} \frac{\text{in-lb}}{\text{in-lb}} .$$

(E9.8)

The thermal expansion coefficients for each ply can be calculated from equation (90):

For the +45° ply:

$$\alpha_x = 16.16 \times 10^{-6} \frac{\text{in}}{\text{F}^\circ} ; \alpha_y = 16.16 \times 10^{-6} \frac{\text{in}}{\text{F}^\circ} ; \alpha_{xy} = -16.24 \times 10^{-6} \frac{\text{in}}{\text{F}^\circ} .$$

For the 0° ply:

$$\alpha_x = -0.072 \times 10^{-6} \frac{\text{in}}{\text{F}^\circ} ; \alpha_y = 32.4 \times 10^{-6} \frac{\text{in}}{\text{F}^\circ} ; \alpha_{xy} = 0 \frac{\text{in}}{\text{F}^\circ} .$$

For the 90° ply:

$$\alpha_x = 32.4 \times 10^{-6} \frac{\text{in}}{\text{F}^\circ} ; \alpha_y = -0.072 \times 10^{-6} \frac{\text{in}}{\text{F}^\circ} ; \alpha_{xy} = 0 \frac{\text{in}}{\text{F}^\circ} .$$

The thermal stresses in each ply can be found using equation (91).

For the +45° ply:

$$\begin{aligned}\varepsilon_x^T &= \alpha_x \Delta T = 16.16 \times 10^{-6} \frac{1}{\text{F}^\circ} (-280 \text{ }^\circ\text{F}) = -0.004525 , \\ \varepsilon_y^T &= \alpha_y \Delta T = 16.16 \times 10^{-6} \frac{1}{\text{F}^\circ} (-280 \text{ }^\circ\text{F}) = -0.004525 , \\ \gamma_{xy}^T &= 2\alpha_{xy} \Delta T = -32.48 \times 10^{-6} \frac{1}{\text{F}^\circ} (-280 \text{ }^\circ\text{F}) = 0.009094 .\end{aligned}\tag{E9.9}$$

For the 0° ply:

$$\begin{aligned}\varepsilon_x^T &= \alpha_x \Delta T = -0.072 \times 10^{-6} \frac{1}{\text{F}^\circ} (-280 \text{ }^\circ\text{F}) = 0.00002016 , \\ \varepsilon_y^T &= \alpha_y \Delta T = 32.4 \times 10^{-6} \frac{1}{\text{F}^\circ} (-280 \text{ }^\circ\text{F}) = -0.009072 , \\ \gamma_{xy}^T &= 2\alpha_{xy} \Delta T = 0 \frac{1}{\text{F}^\circ} (-280 \text{ }^\circ\text{F}) = 0 .\end{aligned}\tag{E9.10}$$

For the 90° ply;

$$\begin{aligned}\varepsilon_x^T &= \alpha_x \Delta T = 32.4 \times 10^{-6} \frac{1}{\text{C}^\circ} (-280 \text{ }^\circ\text{C}) = -0.009072 , \\ \varepsilon_y^T &= \alpha_y \Delta T = -0.072 \times 10^{-6} \frac{1}{\text{C}^\circ} (-280 \text{ }^\circ\text{C}) = 0.00002016 , \\ \gamma_{xy}^T &= 2\alpha_{xy} \Delta T = 0 \frac{1}{\text{C}^\circ} (-280 \text{ }^\circ\text{C}) = 0 .\end{aligned}\tag{E9.11}$$

The thermal stress resultants can be found using equation (92):

$$\begin{aligned}
 \begin{bmatrix} N_x^T \\ N_y^T \\ N_{xy}^T \end{bmatrix} &= \left(\begin{aligned} &\begin{bmatrix} 6.557 & 4.555 & 4.705 \\ 4.555 & 6.557 & 4.705 \\ 4.705 & 4.705 & 5.164 \end{bmatrix} \begin{bmatrix} -0.004525 \\ -0.004525 \\ 0.009094 \end{bmatrix} + \\ &+ \\ &\begin{bmatrix} 20.131 & 0.393 & 0 \\ 0.393 & 1.309 & 0 \\ 0 & 0 & 1.001 \end{bmatrix} \begin{bmatrix} 0.00002016 \\ -0.009072 \\ 0 \end{bmatrix} + \\ &\begin{bmatrix} 1.309 & 0.393 & 0 \\ 0.393 & 20.131 & 0 \\ 0 & 0 & 1.001 \end{bmatrix} \begin{bmatrix} -0.009072 \\ 0.00002016 \\ 0 \end{bmatrix} \end{aligned} \right) \times 10^6 (0.005 \text{ in}) \text{ lb/in}^2 \\
 &= \begin{bmatrix} -112.6 \\ -112.6 \\ 21.91 \end{bmatrix} \frac{\text{lb}}{\text{in}}
 \end{aligned} \tag{E9.12}$$

The thermal moment resultant is given by equation (93):

$$\begin{aligned}
 \begin{bmatrix} M_x^T \\ M_y^T \\ M_{xy}^T \end{bmatrix} &= \left(\begin{aligned} &\begin{bmatrix} 6.557 & 4.555 & 4.705 \\ 4.555 & 6.557 & 4.705 \\ 4.705 & 4.705 & 5.164 \end{bmatrix} \begin{bmatrix} -0.004525 \\ -0.004525 \\ 0.009094 \end{bmatrix} (0.005 \text{ in}) + \\ &\begin{bmatrix} 20.131 & 0.393 & 0 \\ 0.393 & 1.309 & 0 \\ 0 & 0 & 1.001 \end{bmatrix} \begin{bmatrix} 0.00002016 \\ -0.009072 \\ 0 \end{bmatrix} (0 \text{ in}) + \\ &\begin{bmatrix} 1.309 & 0.393 & 0 \\ 0.393 & 20.131 & 0 \\ 0 & 0 & 1.001 \end{bmatrix} \begin{bmatrix} -0.009072 \\ 0.00002016 \\ 0 \end{bmatrix} (-0.005 \text{ in}) \end{aligned} \right) \times 10^6 (0.005 \text{ in}) \text{ lb/in}^2 \\
 &= \begin{bmatrix} 0.1093 \\ -0.1084 \\ 0.1095 \end{bmatrix} \text{ lb}
 \end{aligned} \tag{E9.13}$$

The mechanical stress and moment resultants have only one component due to the applied load; $M_x = -16.7$ lb. Thus, the complete set of stress and moment resultants are:

$$\begin{bmatrix} N_x^{Tot} \\ N_y^{Tot} \\ N_{xy}^{Tot} \\ M_x^{Tot} \\ M_y^{Tot} \\ M_{xy}^{Tot} \end{bmatrix} = \begin{bmatrix} -112.6 \frac{\text{lb}}{\text{in}} \\ -112.6 \frac{\text{lb}}{\text{in}} \\ 21.91 \frac{\text{lb}}{\text{in}} \\ 0.1093 \text{ lb} \\ -0.1084 \text{ lb} \\ 0.1095 \text{ lb} \end{bmatrix} \quad (\text{E9.14})$$

The midplane strains and curvatures can now be calculated from the constitutive equations (52).

$$\begin{aligned} \varepsilon_x^0 &= [(8.5)(-112.6) - (0.91)(-112.6) - (2.175)(21.91)] \times 10^{-6} \\ &\quad + [(-299)(0.1093) - (120)(-0.1084) - (467)(0.1095)] \times 10^{-6} = -0.0009731 \\ \varepsilon_y^0 &= [(-0.91)(-112.6) + (18.1)(-112.6) - (10.3)(21.91)] \times 10^{-6} \\ &\quad + [(-427)(0.1093) + (2,614)(-0.1084) - (2,765)(0.1095)] \times 10^{-6} = -0.002794 \\ \gamma_{xy}^0 &= [(-2.175)(-112.6) - (10.3)(-112.6) + (55.2)(21.91)] \times 10^{-6} \\ &\quad + [(-1,932)(0.1093) - (1,959)(-0.1084) - (2,124)(0.1095)] \times 10^{-6} = 0.002383 \\ K_x &= [(-299)(-112.6) - (427)(-112.6) - (1,932)(21.91)] \times 10^{-6} \\ &\quad + [(1.41)(0.1093) - (0.119)(-0.1084) - (0.633)(0.1095)] = 0.1371 \frac{1}{\text{in}} \\ K_y &= [(-120)(-112.6) + (2,614)(-112.6) - (1,959)(21.91)] \times 10^{-6} \\ &\quad + [(-0.119)(0.1093) + (0.706)(-0.1084) - (0.548)(0.1095)] = -0.4733 \frac{1}{\text{in}} \end{aligned} \quad (\text{E9.15})$$

$$K_{xy} = [(-467)(-112.6) - (2,764)(-112.6) - (2,124)(21.91)] \times 10^{-6} \\ + [(-0.633)(0.1093) - (0.548)(-0.1084) + (2.79)(0.1095)] = 0.6130 \frac{\text{in}}{\text{in}}$$

Now equation (30) can be used to find the strains within the laminate, and once these are found, equation (23) can be used to find the stresses.

At the top of the +45° ply, $z = 0.0075$ in:

$$\begin{bmatrix} \varepsilon_x \\ \varepsilon_y \\ \gamma_{xy} \end{bmatrix}_{+45}^{\text{Top}} = \begin{bmatrix} -0.0009731 \\ -0.002794 \\ 0.002383 \end{bmatrix} + 0.0075 \text{ in} \begin{bmatrix} 0.1371 \\ -0.4733 \\ 0.6130 \end{bmatrix} \frac{1}{\text{in}} = \begin{bmatrix} 0.000055 \\ -0.006344 \\ 0.006981 \end{bmatrix} \quad (\text{E9.16})$$

At the bottom of the +45° ply (the top of the 0° ply, $z = 0.0025$ in:

$$\begin{bmatrix} \varepsilon_x \\ \varepsilon_y \\ \gamma_{xy} \end{bmatrix}_{+45}^{\text{Bot.}} = \begin{bmatrix} -0.0009731 \\ -0.002794 \\ 0.002383 \end{bmatrix} + 0.0025 \text{ in} \begin{bmatrix} 0.1371 \\ -0.4733 \\ 0.6130 \end{bmatrix} \frac{1}{\text{in}} = \begin{bmatrix} -0.000630 \\ -0.003977 \\ 0.00391 \end{bmatrix} \quad (\text{E9.17})$$

At the bottom of the 0° ply (the top of the 90° ply), $z = -0.0025$ in:

$$\begin{bmatrix} \varepsilon_x \\ \varepsilon_y \\ \gamma_{xy} \end{bmatrix}_0^{\text{Bot.}} = \begin{bmatrix} -0.0009731 \\ -0.002794 \\ 0.002383 \end{bmatrix} - 0.0025 \text{ in} \begin{bmatrix} 0.1371 \\ -0.4733 \\ 0.6130 \end{bmatrix} \frac{1}{\text{in}} = \begin{bmatrix} -0.001316 \\ -0.001611 \\ 0.000851 \end{bmatrix} \quad (\text{E9.18})$$

At the bottom of the 90° ply, $z = -0.0075$ in:

$$\begin{bmatrix} \varepsilon_x \\ \varepsilon_y \\ \gamma_{xy} \end{bmatrix}_{90}^{\text{Bot.}} = \begin{bmatrix} -0.0009731 \\ -0.002794 \\ 0.002383 \end{bmatrix} - 0.0075 \text{ in} \begin{bmatrix} 0.1371 \\ -0.4733 \\ 0.6130 \end{bmatrix} \frac{1}{\text{in}} = \begin{bmatrix} -0.002001 \\ 0.000756 \\ -0.002215 \end{bmatrix} \quad (\text{E9.19})$$

Transforming the +45° ply strains into principal material strains:

$$\begin{bmatrix} \varepsilon_1 \\ \varepsilon_2 \\ \frac{\gamma_{12}}{2} \end{bmatrix}_{+45}^{\text{Top}} = \begin{bmatrix} 0.5 & 0.5 & 1 \\ 0.5 & 0.5 & -1 \\ -0.5 & 0.5 & 0 \end{bmatrix} \begin{bmatrix} 0.000055 \\ -0.006344 \\ \frac{0.006981}{2} \end{bmatrix} = \begin{bmatrix} 0.000346 \\ -0.006635 \\ -0.003200 \end{bmatrix} \quad (\text{E9.20})$$

$$\Rightarrow \begin{bmatrix} \varepsilon_1 \\ \varepsilon_2 \\ \gamma_{12} \end{bmatrix} = \begin{bmatrix} 0.000346 \\ -0.006635 \\ -0.006400 \end{bmatrix} .$$

$$\begin{bmatrix} \varepsilon_1 \\ \varepsilon_2 \\ \frac{\gamma_{12}}{2} \end{bmatrix}_{+45}^{\text{Bot.}} = \begin{bmatrix} 0.5 & 0.5 & 1 \\ 0.5 & 0.5 & -1 \\ -0.5 & 0.5 & 0 \end{bmatrix} \begin{bmatrix} -0.00063 \\ -0.003977 \\ \frac{0.003916}{2} \end{bmatrix} = \begin{bmatrix} -0.000346 \\ -0.004262 \\ -0.001674 \end{bmatrix} \quad (\text{E9.21})$$

$$\Rightarrow \begin{bmatrix} \varepsilon_1 \\ \varepsilon_2 \\ \gamma_{12} \end{bmatrix} = \begin{bmatrix} -0.000346 \\ -0.004262 \\ -0.003348 \end{bmatrix} .$$

The stresses in the laminate material directions are;

Note: Recall that the thermal strains must be subtracted out of the total strain.

$$\begin{bmatrix} \sigma_x \\ \sigma_y \\ \tau_{xy} \end{bmatrix}_{+45}^{\text{Top}} = \begin{bmatrix} 6.557 & 4.555 & 4.705 \\ 4.555 & 6.557 & 4.705 \\ 4.705 & 4.705 & 5.164 \end{bmatrix} \times 10^6 \text{ lb/in}^2 \begin{bmatrix} 0.000055 - (-0.004525) \\ -0.006344 - (-0.004525) \\ 0.006981 - 0.009094 \end{bmatrix} = \begin{bmatrix} 11.80 \\ -1.01 \\ 2.08 \end{bmatrix} \text{ ksi} , \quad (\text{E9.22})$$

$$\begin{bmatrix} \sigma_x \\ \sigma_y \\ \tau_{xy} \end{bmatrix}_{+45}^{\text{Bot.}} = \begin{bmatrix} 6.557 & 4.555 & 4.705 \\ 4.555 & 6.557 & 4.705 \\ 4.705 & 4.705 & 5.164 \end{bmatrix} \times 10^6 \text{ lb/in}^2 \begin{bmatrix} -0.000630 - (-0.004525) \\ -0.003977 - (-0.004525) \\ 0.003916 - 0.009094 \end{bmatrix} = \begin{bmatrix} 3.67 \\ -3.03 \\ -5.83 \end{bmatrix} \text{ ksi} , \quad (\text{E9.23})$$

$$\begin{bmatrix} \sigma_x \\ \sigma_y \\ \tau_{xy} \end{bmatrix}_0^{\text{Top}} = \begin{bmatrix} 20.131 & 0.393 & 0 \\ 0.393 & 1.309 & 0 \\ 0 & 0 & 1.001 \end{bmatrix} \times 10^6 \text{ lb/in}^2 \begin{bmatrix} -0.000630 & -0.00002016 \\ -0.003977 & -(-0.009072) \\ 0.003916 & -0 \end{bmatrix} = \begin{bmatrix} -11.09 \\ 6.41 \\ 3.92 \end{bmatrix} \text{ ksi} , \quad (\text{E9.24})$$

$$\begin{bmatrix} \sigma_x \\ \sigma_y \\ \tau_{xy} \end{bmatrix}_0^{\text{Bot}} = \begin{bmatrix} 20.131 & 0.393 & 0 \\ 0.393 & 1.309 & 0 \\ 0 & 0 & 1.001 \end{bmatrix} \times 10^6 \text{ lb/in}^2 \begin{bmatrix} -0.001316 & -0.00002016 \\ -0.001611 & -(-0.009072) \\ 0.000851 & -0 \end{bmatrix} = \begin{bmatrix} -24.0 \\ 9.24 \\ 0.85 \end{bmatrix} \text{ ksi} , \quad (\text{E9.25})$$

$$\begin{bmatrix} \sigma_x \\ \sigma_y \\ \tau_{xy} \end{bmatrix}_{90}^{\text{Top}} = \begin{bmatrix} 1.309 & 0.393 & 0 \\ 0.393 & 20.131 & 0 \\ 0 & 0 & 1.001 \end{bmatrix} \times 10^6 \text{ lb/in}^2 \begin{bmatrix} -0.001316 & -(-0.009072) \\ -0.001611 & -0.00002016 \\ 0.000851 & -0 \end{bmatrix} = \begin{bmatrix} 9.51 \\ -29.8 \\ 0.85 \end{bmatrix} \text{ ksi} , \quad (\text{E9.26})$$

$$\begin{bmatrix} \sigma_x \\ \sigma_y \\ \tau_{xy} \end{bmatrix}_{90}^{\text{Top}} = \begin{bmatrix} 1.309 & 0.393 & 0 \\ 0.393 & 20.131 & 0 \\ 0 & 0 & 1.001 \end{bmatrix} \times 10^6 \text{ lb/in}^2 \begin{bmatrix} -0.002001 & -(-0.009072) \\ -0.000756 & -0.00002016 \\ 0.002215 & -0 \end{bmatrix} = \begin{bmatrix} 9.55 \\ 17.6 \\ -2.22 \end{bmatrix} \text{ ksi} . \quad (\text{E9.27})$$

Transforming these stresses into the +45° ply's principal material directions;

$$\begin{bmatrix} \sigma_1 \\ \sigma_2 \\ \tau_{12} \end{bmatrix}_{+45}^{\text{Top}} = \begin{bmatrix} 0.5 & 0.5 & 1 \\ 0.5 & 0.5 & -1 \\ -0.5 & 0.5 & 0 \end{bmatrix} \begin{bmatrix} 11.80 \\ -1.01 \\ 2.08 \end{bmatrix} \text{ ksi} = \begin{bmatrix} 7.48 \\ 3.32 \\ -6.41 \end{bmatrix} \text{ ksi} , \quad (\text{E9.28})$$

$$\begin{bmatrix} \sigma_1 \\ \sigma_2 \\ \tau_{12} \end{bmatrix}_{+45}^{\text{Bot}} = \begin{bmatrix} 0.5 & 0.5 & 1 \\ 0.5 & 0.5 & -1 \\ -0.5 & 0.5 & 0 \end{bmatrix} \begin{bmatrix} 3.67 \\ -3.03 \\ -5.83 \end{bmatrix} \text{ ksi} = \begin{bmatrix} -5.51 \\ 6.15 \\ -3.35 \end{bmatrix} \text{ ksi} . \quad (\text{E9.29})$$

Putting the strain and stress results into tabular form:

Ply Strains

Location	ϵ_x	ϵ_y	γ_{xy}	ϵ_1	ϵ_2	γ_{12}
Top +45	0.000055	-0.006344	0.006981	0.000346	-0.006635	-0.006400
Bot. +45	-0.000630	-0.003977	0.003916	-0.000346	-0.004262	-0.003348
Top 0	-0.000630	-0.003977	0.003916	-0.000630	-0.003977	0.003916
Bot. 0	-0.001316	-0.001611	0.000851	-0.001316	-0.001611	0.000851
Top 90	-0.001316	-0.001611	0.000851	-0.001611	-0.001316	-0.000851
Bot. 90	-0.002001	0.000756	-0.002215	0.000756	-0.002001	0.002215

Ply Stresses in ksi

Location	σ_x	σ_y	τ_{xy}	σ_1	σ_2	τ_{12}
Top +45	11.80	-1.01	2.08	7.48	3.32	-6.41
Bot. +45	3.67	-3.03	-5.83	-5.51	6.15	-3.35
Top 0	-11.09	6.41	3.92	-11.09	6.41	3.92
Bot. 0	-24.0	9.24	0.85	-24.0	9.24	0.85
Top 90	9.51	-29.8	0.85	-29.8	9.51	-0.85
Bot. 90	9.55	17.6	-2.22	17.6	9.55	2.22

The deformed shape of the plate can be predicted from the midplane strain and plate curvature results:

$$\begin{aligned}
 \epsilon_x^0 &= -0.0009731 \text{ ,} \\
 \epsilon_y^0 &= -0.002794 \text{ ,} \\
 \gamma_{xy}^0 &= 0.002383 \text{ ,} \\
 K_x &= 0.1371 \frac{1}{\text{in}} \text{ ,} \\
 K_y &= -0.4733 \frac{1}{\text{in}} \text{ ,} \\
 K_{xy} &= 0.6130 \frac{1}{\text{in}} \text{ .}
 \end{aligned}
 \tag{E9.30}$$

From the definition of plate curvatures, equation (29), it is seen that these can be used to find the out-of-plane displacements w .

Along the edge parallel to the 0° fibers (the x -direction) the plate will bend with a change in w of:

$$w(x) = \int_{x_1}^{x_2} \int_{x_1}^{x_2} -K_x = -0.1371 \frac{1}{\text{in}} (x_2 - x_1)^2 + w_0 (x_2 - x_1) + w_0 \text{ .}
 \tag{E9.31}$$

Let $w_0 = 0$ and $x_1 = 0$. This edge will vary parabolically with length as shown in the following:

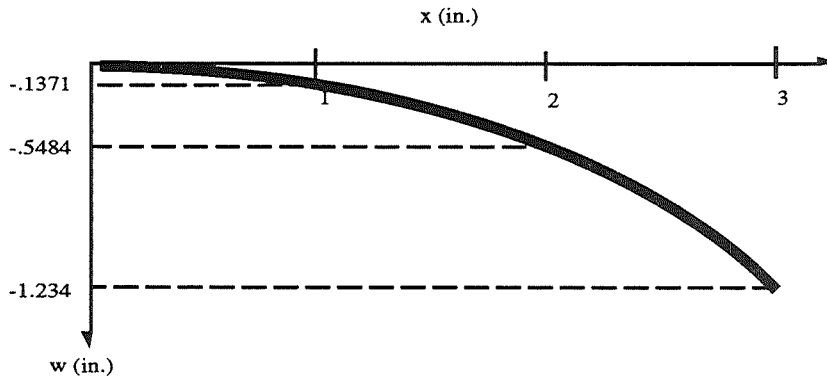

Along the edge perpendicular to the 0° ply fibers (the y-direction):

$$w(y) = \int_{y_1}^{y_2} \int_{y_1}^{y_2} -K_y = -0.4733 \frac{(y_2 - y_1)^2}{\text{in}} + w_0 (y_2 - y_1) + w_0 \quad (\text{E9.32})$$

This edge will also vary parabolically, but with a different bending direction with a more pronounced curvature.

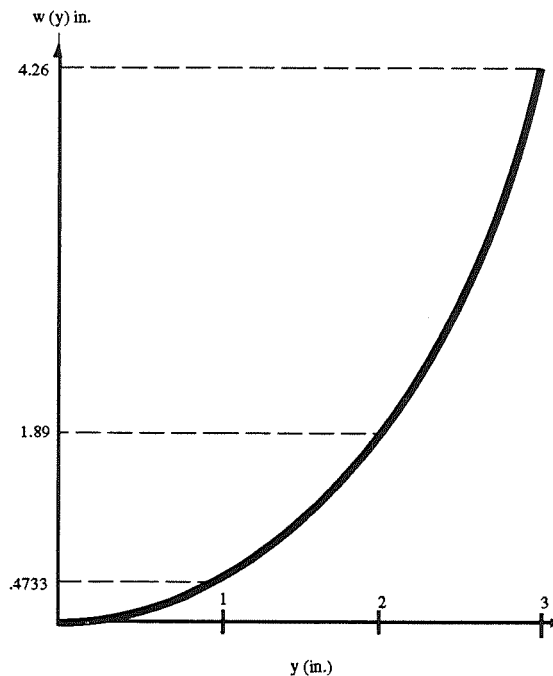

There will also be a twist to the plate:

$$w(x,y) = \int_{x_1}^{x_2} \int_{y_1}^{y_2} -K_{xy} = -0.613 \frac{1}{\text{in}} (y_2 - y_1)(x_2 - x_1) + w_0(x_2 - x_1) + w_0 \quad (E9.33)$$

Again letting $w_0 = 0$ and x_1 and $y_1 = 0$:

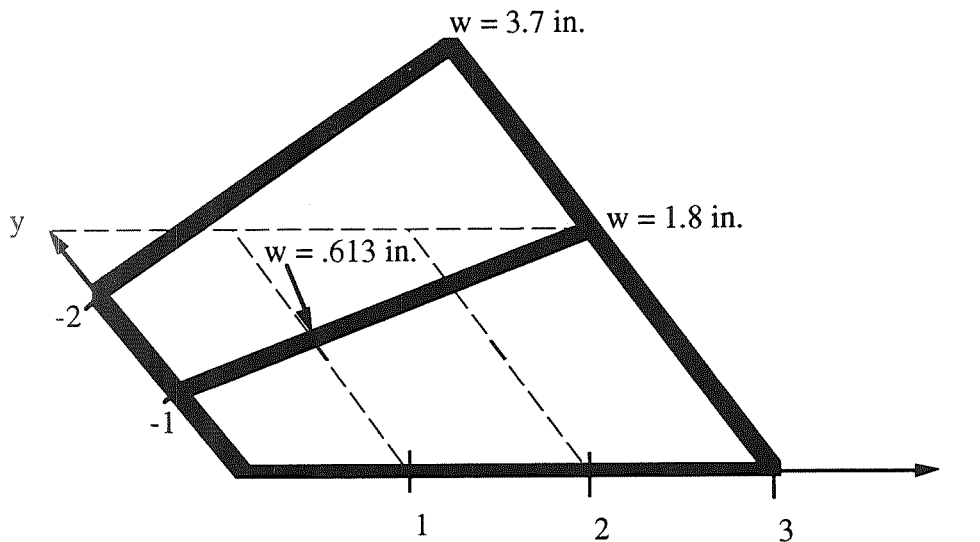

Superimposing the three curvatures will demonstrate what the plate will look like after it cures to room temperature:

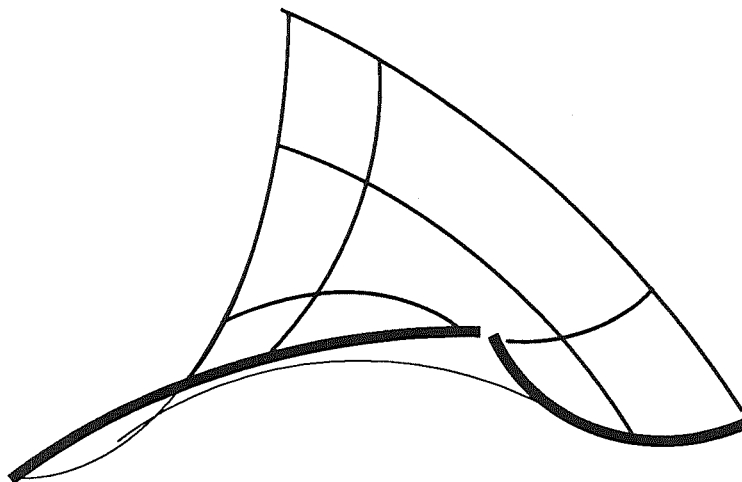

IX. REFERENCE OF IMPORTANT EQUATIONS

Transformation matrix:

$$[T] = \begin{bmatrix} \cos^2 \theta & \sin^2 \theta & 2 \sin \theta \cos \theta \\ \sin^2 \theta & \cos^2 \theta & -2 \sin \theta \cos \theta \\ -\sin \theta \cos \theta & \sin \theta \cos \theta & (\cos^2 \theta - \sin^2 \theta) \end{bmatrix} \begin{bmatrix} \sigma_x \\ \sigma_y \\ \tau_{xy} \end{bmatrix},$$

$$[T]^{-1} = \begin{bmatrix} \cos^2 \theta & \sin^2 \theta & -2 \sin \theta \cos \theta \\ \sin^2 \theta & \cos^2 \theta & 2 \sin \theta \cos \theta \\ \sin \theta \cos \theta & -\sin \theta \cos \theta & (\cos^2 \theta - \sin^2 \theta) \end{bmatrix},$$

$$\begin{bmatrix} \sigma_1 \\ \sigma_2 \\ \tau_{12} \end{bmatrix} = [T] \begin{bmatrix} \sigma_x \\ \sigma_y \\ \tau_{xy} \end{bmatrix},$$

$$\begin{bmatrix} \sigma_x \\ \sigma_y \\ \tau_{xy} \end{bmatrix} = [T]^{-1} \begin{bmatrix} \sigma_1 \\ \sigma_2 \\ \tau_{12} \end{bmatrix},$$

$$\begin{bmatrix} \varepsilon_1 \\ \varepsilon_2 \\ \varepsilon_{12} \end{bmatrix} = [T] \begin{bmatrix} \varepsilon_x \\ \varepsilon_y \\ \varepsilon_{xy} \end{bmatrix},$$

$$\begin{bmatrix} \varepsilon_x \\ \varepsilon_y \\ \varepsilon_{xy} \end{bmatrix} = [T]^{-1} \begin{bmatrix} \varepsilon_1 \\ \varepsilon_2 \\ \varepsilon_{12} \end{bmatrix}.$$

Stress-strain relationship for a lamina, along the principal material directions:

$$\begin{bmatrix} \sigma_1 \\ \sigma_2 \\ \tau_{12} \end{bmatrix} = \begin{bmatrix} Q_{11} & Q_{12} & 0 \\ Q_{12} & Q_{22} & 0 \\ 0 & 0 & Q_{66} \end{bmatrix} \begin{bmatrix} \varepsilon_1 \\ \varepsilon_2 \\ \gamma_{12} \end{bmatrix} ,$$

$$Q_{11} = \frac{E_1}{1-\nu_{12}\nu_{21}} \quad Q_{22} = \frac{E_2}{1-\nu_{12}\nu_{21}} ,$$

$$Q_{12} = \frac{\nu_{12}E_2}{1-\nu_{12}\nu_{21}} = \frac{\nu_{21}E_1}{1-\nu_{12}\nu_{21}} \quad Q_{66} = G_{12} .$$

Stress-strain relationship for a lamina:

$$\begin{aligned} \bar{Q}_{11} &= Q_{11}m^4 + 2(Q_{12} + 2Q_{66})m^2n^2 + Q_{22}n^4 \\ \bar{Q}_{12} &= (Q_{11} + Q_{22} - 4Q_{66})m^2n^2 + Q_{12}(m^4 + n^4) \\ \bar{Q}_{22} &= Q_{11}n^4 + 2(Q_{12} + 2Q_{66})m^2n^2 + Q_{22}m^4 \\ \bar{Q}_{16} &= (Q_{11} - Q_{12} - 2Q_{66})m^3n + (Q_{12} - Q_{22} + 2Q_{66})mn^3 \\ \bar{Q}_{26} &= (Q_{11} - Q_{12} - 2Q_{66})n^3m + (Q_{12} - Q_{22} + 2Q_{66})nm^3 \\ \bar{Q}_{66} &= (Q_{11} + Q_{22} - 2Q_{12} - 2Q_{66})m^2n^2 + Q_{66}(m^4 + n^4) \end{aligned} ,$$

$$m = \cos \theta$$

$$n = \sin \theta ,$$

$$\begin{bmatrix} \sigma_x \\ \sigma_y \\ \tau_{xy} \end{bmatrix} = \begin{bmatrix} \bar{Q}_{11} & \bar{Q}_{12} & \bar{Q}_{16} \\ \bar{Q}_{12} & \bar{Q}_{22} & \bar{Q}_{26} \\ \bar{Q}_{16} & \bar{Q}_{26} & \bar{Q}_{66} \end{bmatrix} \begin{bmatrix} \varepsilon_x \\ \varepsilon_y \\ \gamma_{xy} \end{bmatrix} .$$

Laminate constitutive equations:

$$\begin{bmatrix} N_x \\ N_y \\ N_{xy} \\ \hline M_x \\ M_y \\ M_{xy} \end{bmatrix} = \begin{bmatrix} A_{11} & A_{12} & A_{16} & | & B_{11} & B_{12} & B_{16} \\ A_{12} & A_{22} & A_{26} & | & B_{12} & B_{22} & B_{26} \\ A_{16} & A_{26} & A_{66} & | & B_{16} & B_{26} & B_{66} \\ \hline B_{11} & B_{12} & B_{16} & | & D_{11} & D_{12} & D_{16} \\ B_{12} & B_{22} & B_{26} & | & D_{12} & D_{22} & D_{26} \\ B_{16} & B_{26} & B_{66} & | & D_{16} & D_{26} & D_{66} \end{bmatrix} \begin{bmatrix} \epsilon_x^0 \\ \epsilon_y^0 \\ \epsilon_{xy}^0 \\ \hline K_x \\ K_y \\ K_{xy} \end{bmatrix}$$

Extensional stiffness matrix:

$$A_{ij} = \sum_{k=1}^n [\bar{Q}_{ij}]_k t_k \cdot$$

Coupling stiffness matrix:

$$B_{ij} = \sum_{k=1}^n [\bar{Q}_{ij}]_k t_k z_k^{-2} \cdot$$

Bending stiffness matrix:

$$D_{ij} = \sum_{k=1}^n [\bar{Q}_{ij}]_k \left(\frac{t_k^3}{12} + t_k z_k^{-2} \right) \cdot$$

Partially inverted forms:

$$[A^*] = [A]^{-1} \cdot$$

$$[B^*] = -[A]^{-1}[B] \cdot$$

$$[C^*] = [B][A]^{-1} \cdot$$

$$[D^*] = [D] - [B][A]^{-1}[B] \cdot$$

Fully inverted forms:

$$[A'] = [A^*] - [B^*][D^*]^{-1}[C^*],$$

$$[B'] = [B^*][D^*]^{-1},$$

$$[C'] = -[D^*]^{-1}[C^*],$$

$$[D'] = [D^*]^{-1}.$$

Fully inverted constitutive equations:

$$\begin{bmatrix} \varepsilon_x^0 \\ \varepsilon_y^0 \\ \gamma_{xy}^0 \\ K_x \\ K_y \\ K_{xy} \end{bmatrix} = \begin{bmatrix} A'_{11} & A'_{12} & A'_{16} & B'_{11} & B'_{12} & B'_{16} \\ A'_{12} & A'_{22} & A'_{26} & B'_{12} & B'_{22} & B'_{26} \\ A'_{16} & A'_{26} & A'_{66} & B'_{16} & B'_{26} & B'_{66} \\ \hline C'_{11} & C'_{12} & C'_{16} & D'_{11} & D'_{12} & D'_{16} \\ C'_{12} & C'_{22} & C'_{26} & D'_{12} & D'_{22} & D'_{26} \\ C'_{16} & C'_{26} & C'_{66} & D'_{16} & D'_{26} & D'_{66} \end{bmatrix} \begin{bmatrix} N_x \\ N_y \\ N_{xy} \\ M_x \\ M_y \\ M_{xy} \end{bmatrix}.$$

Strains within a laminate:

$$\begin{bmatrix} \varepsilon_x \\ \varepsilon_y \\ \gamma_{xy} \end{bmatrix} = \begin{bmatrix} \varepsilon_x^o \\ \varepsilon_y^o \\ \gamma_{xy}^o \end{bmatrix} + z \begin{bmatrix} K_x \\ K_y \\ K_{xy} \end{bmatrix},$$

Engineering constants for symmetric laminates:

$$E_x = \frac{A_{11}}{h} + \frac{A_{12}}{h} \left(\frac{A_{26}A_{16} - A_{12}A_{66}}{A_{22}A_{66} - A_{26}^2} \right) + \frac{A_{16}}{h} \left(\frac{-A_{16}}{A_{66}} + \frac{A_{26}A_{12}A_{66} - A_{26}^2A_{16}}{A_{22}A_{66}^2 - A_{26}^2A_{66}} \right),$$

$$E_y = \frac{A_{12}}{h} \left(\frac{A_{16}A_{26} - A_{12}A_{66}}{A_{11}A_{66} - A_{16}^2} \right) + \frac{A_{22}}{h} + \frac{A_{26}}{h} \left(\frac{-A_{26}}{A_{66}} + \frac{A_{16}A_{12}A_{66} - A_{16}^2A_{26}}{A_{11}A_{66}^2 - A_{16}^2A_{66}} \right),$$

$$G_{xy} = \frac{A_{66}}{h} - \frac{A_{26}^2}{(h)A_{22}} + \frac{2A_{12}A_{16}A_{26}A_{22} - A_{12}^2A_{26}^2 - A_{16}^2A_{22}^2}{h(A_{11}A_{22}^2 - A_{12}^2A_{22})}$$

$$v_{xy} = \frac{\left(A_{12} - \frac{A_{16}A_{26}}{A_{66}} \right)}{\left(A_{22} - \frac{A_{26}^2}{A_{66}} \right)}$$

$$v_{yx} = \frac{\left(\frac{A_{16}A_{26}}{A_{66}} - A_{12} \right)}{\left(\frac{A_{16}^2}{A_{66}} - A_{11} \right)}$$

Thermal strains:

$$\varepsilon_x^T = \alpha_x \Delta T \quad ,$$

$$\varepsilon_y^T = \alpha_y \Delta T \quad ,$$

$$\varepsilon_{xy}^T = \frac{\gamma_{xy}^T}{2} = \alpha_{xy} \Delta T \quad .$$

Thermal stress and moment resultants:

$$\begin{bmatrix} N_x^T \\ N_y^T \\ N_{xy}^T \end{bmatrix} = \sum_{k=1}^n \begin{bmatrix} \bar{Q}_{11} & \bar{Q}_{12} & \bar{Q}_{16} \\ \bar{Q}_{12} & \bar{Q}_{22} & \bar{Q}_{26} \\ \bar{Q}_{16} & \bar{Q}_{26} & \bar{Q}_{66} \end{bmatrix}_k \begin{bmatrix} \varepsilon_x^T \\ \varepsilon_y^T \\ \gamma_{xy}^T \end{bmatrix}_k t_k \quad ,$$

$$\begin{bmatrix} M_x^T \\ M_y^T \\ M_{xy}^T \end{bmatrix} = \sum_{k=1}^n \begin{bmatrix} \bar{Q}_{11} & \bar{Q}_{12} & \bar{Q}_{16} \\ \bar{Q}_{12} & \bar{Q}_{22} & \bar{Q}_{26} \\ \bar{Q}_{16} & \bar{Q}_{26} & \bar{Q}_{66} \end{bmatrix}_k \begin{bmatrix} \varepsilon_x^T \\ \varepsilon_y^T \\ \gamma_{xy}^T \end{bmatrix}_k t_k \bar{z}_k \quad .$$

Total stress and moment resultants:

$$\begin{bmatrix} N_x^{\text{Tot}} \\ N_y^{\text{Tot}} \\ N_{xy}^{\text{Tot}} \end{bmatrix} = \begin{bmatrix} N_x^T \\ N_y^T \\ N_{xy}^T \end{bmatrix} + \begin{bmatrix} N_x \\ N_y \\ N_{xy} \end{bmatrix} \quad \text{and} \quad \begin{bmatrix} M_x^{\text{Tot}} \\ M_y^{\text{Tot}} \\ M_{xy}^{\text{Tot}} \end{bmatrix} = \begin{bmatrix} M_x^T \\ M_y^T \\ M_{xy}^T \end{bmatrix} + \begin{bmatrix} M_x \\ M_y \\ M_{xy} \end{bmatrix} .$$

REFERENCES

1. Jones, R.M.: "Mechanics of Composite Materials." New York: McGraw-Hill, 1975.
2. Halpin, J.C.: "Primer on Composite Materials: Analysis." Revised edition, Technomic Publishing Co., Inc., 1984.

APPENDIX

A Fortran program to find the determinant of a 6×6 matrix is given below:

```
C THIS PROGRAM CALCULATES THE DETERMINANT  
C OF A 6 X 6 MATRIX WITH ELEMENTS "E"  
C
```

```
REAL E(6,6), ES(6,6), M  
INTEGER TAG,I,J,N  
M=1  
N=1  
DO 10 I=1,6  
PRINT *, 'ENTER ROW #, I, 'OF THE MATRIX'  
READ *, E(I,1),E(I,2),E(I,3),E(I,4),E(I,5),E(I,6)  
10 CONTINUE  
40 CONTINUE  
TAG=N  
DO 75 I=N,5  
IF (ABS(E(TAG,N)) .GT. E(I+1,N)) THEN  
TAG=TAG  
ELSE  
TAG=I+1  
ENDIF  
75 CONTINUE  
DO 80 J=N,6  
ES(N,J)=E(TAG,J)  
ES(TAG,J)=E(N,J)  
80 CONTINUE  
DO 90 J=N,6  
E(N,J)=ES(N,J)  
E(TAG,J)=ES(TAG,J)  
90 CONTINUE  
M=M*E(N,N)  
DO 91 J=N,6  
ES(N,J)=E(N,J)/E(N,N)  
91 CONTINUE  
DO 95 J=N,6  
E(N,J)=ES(N,J)  
95 CONTINUE  
DO 200 I=N+1,6  
DO 150 J=N,6  
ES(I,J)=(-1*E(I,N)*E(N,J))+E(I,J)  
150 CONTINUE  
200 CONTINUE  
DO 300 I=N+1,6  
DO 250 J=N,6  
E(I,J)=ES(I,J)  
250 CONTINUE  
300 CONTINUE
```



```
N=N+1
  IF (N .LT. 6) THEN
GO TO 40
ELSE
CONTINUE
ENDIF
M=M*E(6,6)
PRINT *, 'DETERMINANT =', M
STOP
END
```

The determinant of a 5×5 matrix can be determined in a similar manner, substituting 5 for 6 in the appropriate sections of the above program.

REPORT DOCUMENTATION PAGE

Form Approved
 OMB No. 0704-0188

Public reporting burden for this collection of information is estimated to average 1 hour per response, including the time for reviewing instructions, searching existing data sources, gathering and maintaining the data needed, and completing and reviewing the collection of information. Send comments regarding this burden estimate or any other aspect of this collection of information, including suggestions for reducing this burden, to Washington Headquarters Services, Directorate for Information Operations and Reports, 1215 Jefferson Davis Highway, Suite 1204, Arlington, VA 22202-4302, and to the Office of Management and Budget, Paperwork Reduction Project (0704-0188), Washington, DC 20503.

1. AGENCY USE ONLY (Leave blank)		2. REPORT DATE October 1994	3. REPORT TYPE AND DATES COVERED Reference Publication	
4. TITLE AND SUBTITLE Basic Mechanics of Laminated Composite Plates			5. FUNDING NUMBERS	
6. AUTHOR(S) Alan T. Nettles				
7. PERFORMING ORGANIZATION NAME(S) AND ADDRESS(ES) George C. Marshall Space Flight Center Marshall Space Flight Center, Alabama 35812			8. PERFORMING ORGANIZATION REPORT NUMBER M-764	
9. SPONSORING / MONITORING AGENCY NAME(S) AND ADDRESS(ES) National Aeronautics and Space Administration Washington, DC 20546			10. SPONSORING / MONITORING AGENCY REPORT NUMBER NASA RP-1351	
11. SUPPLEMENTARY NOTES Prepared by Materials and Processes Laboratory, Science and Engineering Directorate.				
12a. DISTRIBUTION / AVAILABILITY STATEMENT Subject Category: 24 Unclassified—Unlimited			12b. DISTRIBUTION CODE	
13. ABSTRACT (Maximum 200 words) The mechanics of laminated composite materials is presented in a clear manner with only essential derivations included. The constitutive equations in all of their forms are developed and then summarized in a separate section. The effects of hygrothermal effects are included. The prediction of the engineering constants for a laminate are derived. Strength of laminated composites is not covered.				
14. SUBJECT TERMS composite materials, mechanics, laminates, constitutive equations, anisotropic plates			15. NUMBER OF PAGES 102	
			16. PRICE CODE A06	
17. SECURITY CLASSIFICATION OF REPORT Unclassified	18. SECURITY CLASSIFICATION OF THIS PAGE Unclassified	19. SECURITY CLASSIFICATION OF ABSTRACT Unclassified	20. LIMITATION OF ABSTRACT Unlimited	

National Aeronautics and
Space Administration
Code JTT
Washington, DC
20546-0001

*Official Business
Penalty for Private Use, \$300*

Postmaster: If Undeliverable (Section 158 Postal Manual), Do Not Return
